

Carlin®

Combustion Technology

MODEL
601CRD
Commerical Burner
Instruction Manual

WARNING Installer/servicer – Except where specifically stated otherwise, this manual must be used only by a qualified service technician. Failure to comply with this or other requirements in this manual could result in severe personal injury, death or substantial property damage.

WARNING User – The burner Instruction Manual is intended only for your service technician. The burner and heat exchanger must be inspected and started at least annually by your service technician.

NOTICE The National Oilheat Research Alliance (NORA) recommends single pipe oil systems and high-quality filtration for all fuel types. This should include at least a 10 micron Spin-on filter. Double filtration provides even greater assurance clean fuel will get to the pump. Contaminants in the tank that enter the fuel supply to the burner can cause pump sticking/seizing. These contaminants may increase in the early stages of transitioning to modern fuels (Ultra Low Sulfur and Bio Blends). High quality filtration adds protection against pump sticking.

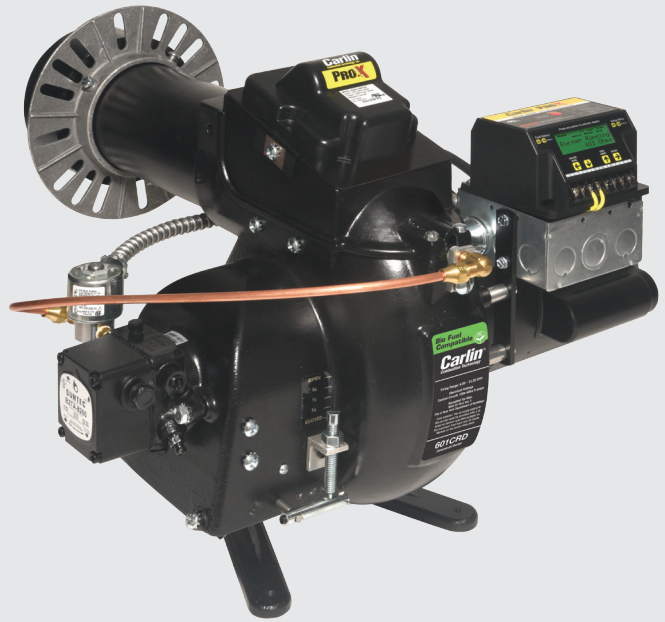

| | |
|--------------------------------------|--|
| Firing Range | 6.00-13.20 GPH* |
| Fuel Specification..... | No. 1 or No.2 Fuel Oil including Bio Blends not exceeding B20 (U.S ONLY) |
| Electrical: | Motor: ½ HP, 3450 RPM, single phase, 60 Hz8.4amps, 120V, (optional 230V available), |
| Ignition: | Carlin Pro-X 45000 Solid State Ignitor, 19,000 volts |
| Control: | Carlin Pro-X 70200, 120V, 60Hz |
| Burner Housing..... | Rugged Casting |
| Blower Wheel Dia. x Width | 6½" OD x 3¾" W |
| 2-Stage Oil Valve Unit Pressure..... | 150 psi |
| Oil Nozzle Specs..... | 45° SS |
| Approximate Shipping Weight | 65 lbs |



Carlin®

Combustion Technology

126 Bailey Road • North Haven, CT 06473
Phone 203-680-9401 • Fax 203-764-1714

TECH SUPPORT 800-989-2275 • carlincombustion.com

© Copyright 2021 — Carlin Combustion Technology

It is important that the installation of the oil burner, piping and fittings, safety devices, controls, electrical wiring and equipment be done in accordance with national and/or local regulations of the authorities having jurisdiction over such installation.

Assembling the Burner (TWO-PAK)

1. Install air tuber assembly in housing using set screws provided.
2. Install and tighten the proper nozzles. Be careful not to damage the electrode insulators or to bend the wires.
3. Check the electrode setting specified as follows:
 $\frac{1}{8}$ inch, $\frac{5}{16}$ inch above the nozzle centerline and $\frac{1}{4}$ inch ahead of the nozzle tips. See Fig 1.

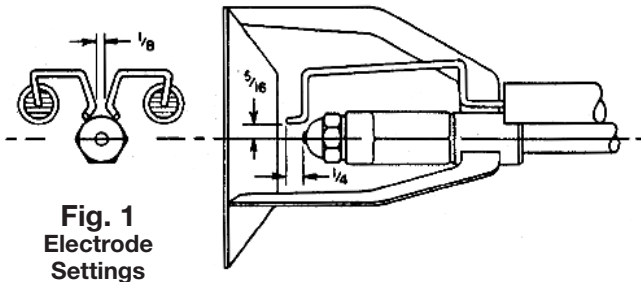

Fig. 1
Electrode
Settings

4. Swing open the ignitor assembly and slide the nozzle line assembly into the air tube.
5. Place the nozzle line yoke in the groove in the adjusting screw.
6. Fasten the high tension leads to the ignitor terminals.
7. Swing the ignitor assembly to the closed position and fasten.
8. Connect the flared fitting on the copper oil line to the nozzle line and tighten.

About Combustion Chambers

The model 601CRD operates with superior efficiency and cleanliness in properly designed refractory-type combustion chambers. Very wide tolerance to burner adjustments and other variables is found when these chambers are used. Noise levels are also reduced.

Table 1, page 3 shows the recommended minimum inside dimensions for refractory brick, refractory pre-cast and pre-formed refractory fiber chambers. Due to their quick warm-up properties, the lightweight insulating-type materials are slightly preferable although these burners show less dependence upon refractory temperature than previous models. Refractory materials in boilers and furnaces should be capable of withstanding 2600°F (1427°C) or higher.

The notes accompanying Table 1 provides further details relative to variations in dimensions and geometry. Refer to Fig. 3, page 3.

Firing Boilers without Refractory Chambers

Depending upon the geometry of the combustion space some units perform better than others without refractory. When the back wall of the unit coincides approximately with the end of the flame, a target of refractory material is essential. Zero smoke readings are made easier if a refractory fiber “rug” or fill material is used on the base under the flame.

Table 1, page 3, together with its footnotes, gives the essential dimensions and information needed to provide conditions for satisfactory operation without complete chambers. Refer to Figs. 4 and 5, page 3.

Installing the Burner: Flange Mounted

1. Measure, in the burner opening, the distance from the inside of the combustion chamber to the outside of the mounting plate to find the insertion length of air tube needed. Position flange on air tube at point from end of burner corresponding to the measurement. Tighten set screws to anchor flange. The flange is now located so that the end of the burner will be flush, or almost flush, with the inside of the combustion chamber. See Fig. 3 (side view) page 3, and Fig. 6, page 3.
2. Slide the end of the air tube into the opening and secure the flange to the front plate.

Installing The Burner: Pedestal Mounted

1. Adjust the pedestal so that the height of the air tube matches the location of the burner opening.
2. Slide the end of the air tube into the opening so that it is flush or nearly flush with the inside of the combustion chamber. See Fig. 7.
3. From the outside of the unit, seal the space around the air tube with refractory cement or equivalent.

Table 1. Recommended Minimum Dimensions of Combustion Chamber for Model 601CRD (inches)

| | | Minimum Inside Dimensions In Refractory Type Combustion Chambers (Ins.) | | | | | Minimum Dimensions In Boilers Fired Without Refractory Chambers (Ins.) | | | | |
|-------------|------------------------------|---|-----------|---------------|------------|---------------|--|---------------------------|-----------|---------------|---------------|
| 1 | 2 | 3 | 4 | 5 | 6 | 7 | 8 | 9 | 10 | 11 | 12 |
| Nozzle Size | Firing Rate (GPH) at 150 psi | Length (L) | Width (W) | Dimension (C) | Height (H) | Vertical CYL. | Length (L) with Target | Length (L) without Target | Width (W) | Dimension (C) | Dimension (D) |
| 5.00 | 6.00 | 18 | 16 | 7.5 | 15 | 16 | 18 | 22 | 18 | 8.5 | 10.5 |
| 5.50 | 6.60 | 19 | 16 | 7.5 | 15 | 17 | 19 | 23 | 18 | 8.5 | 10.5 |
| 6.00 | 7.20 | 20 | 17 | 8.0 | 16 | 18 | 20 | 24 | 19 | 9.0 | 11.0 |
| 6.50 | 7.80 | 22 | 17 | 8.0 | 16 | 20 | 22 | 27 | 19 | 9.0 | 11.0 |
| 7.00 | 8.40 | 24 | 17 | 8.0 | 16 | 22 | 24 | 29 | 19 | 9.0 | 11.0 |
| 7.50 | 9.00 | 27 | 17 | 8.0 | 16 | 25 | 27 | 33 | 19 | 9.0 | 11.0 |
| 8.00 | 9.60 | 30 | 17 | 8.0 | 16 | 28 | 30 | 36 | 19 | 9.0 | 11.0 |
| 8.50 | 10.20 | 31 | 17 | 8.0 | 16 | 29 | 31 | 38 | 19 | 9.0 | 11.0 |
| 9.00 | 10.80 | 33 | 17 | 8.0 | 16 | 31 | 33 | 40 | 19 | 9.0 | 11.0 |
| 9.50 | 11.40 | 35 | 17 | 8.0 | 16 | 33 | 35 | 42 | 19 | 9.0 | 11.0 |
| 10.00 | 12.00 | 38 | 18 | 8.5 | 17 | 36 | 38 | 46 | 20 | 9.5 | 11.5 |
| 11.00 | 13.20 | 42 | 18 | 8.5 | 17 | 40 | 42 | 50 | 20 | 9.5 | 11.5 |

1. Flame lengths are approximately as shown in column (3) when using 45° semi-solid nozzles. Flames approximately 10% shorter are attainable with 45° hollow nozzles. Often, tested boilers or furnaces will operate well with chamber shorter than the lengths shown in column (3).
2. As a general practice any of these dimensions can be exceeded without much effect on combustion.
3. Chambers in the form of horizontal cylinders should be at least as large in diameter as the dimension in column (4). Horizontal stainless steel cylindrical chambers should be 1 to 4 inches larger in diameter than the figures in column (4).
4. Wing walls are not recommended. Corbels are not necessary although they might be of benefit to good heat distribution in certain boiler or furnace designs.
5. A fiber-type refractory "rug" or fill material to cover the floor area of the combustion space in boilers fired without refractory chambers is recommended for cleaner combustion and to protect the base.
6. When a refractory or refractory fiber target is used, the lengths in column (8) apply. If the lengths are equal to or longer than in column (9), no target material is needed unless recommended by the boiler manufacturer.

Fig. 2

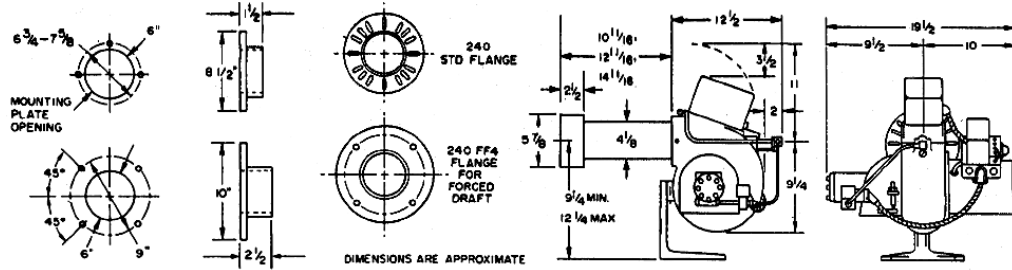
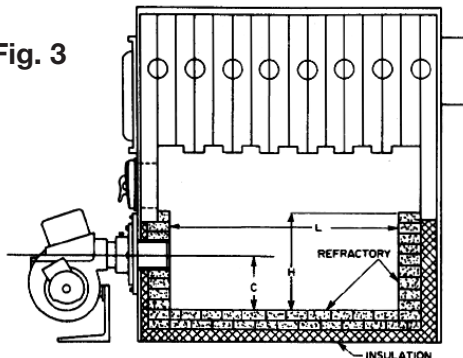
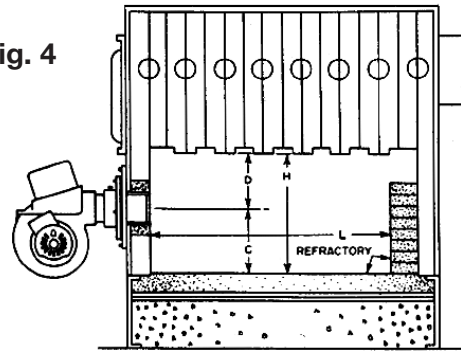

Fig. 3



Brick combustion chamber, side view.

Fig. 4



Wet leg boiler. No combustion chamber, side view.

Fig. 5

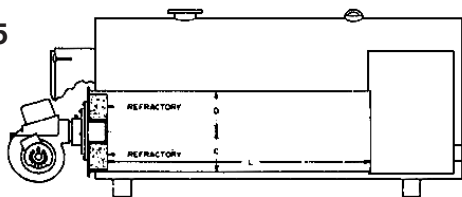

Scotch Marine boiler. No combustion chamber.

Fig. 6

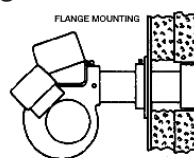
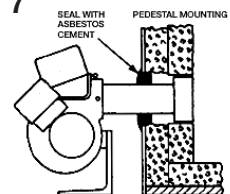

Fig. 7



Installing and Wiring

WARNING The 70200 control must be installed and serviced only by a qualified service technician.

Always disconnect power source before wiring to avoid electrical shock or damage to the control. All wiring must comply with applicable codes and ordinances.

Mounting

The location must not exceed the ambient temperature limit, 140°F.

Wiring

Wiring must comply with local and national electrical codes, and with the following wiring diagrams.

6-Wire Recommended Wiring

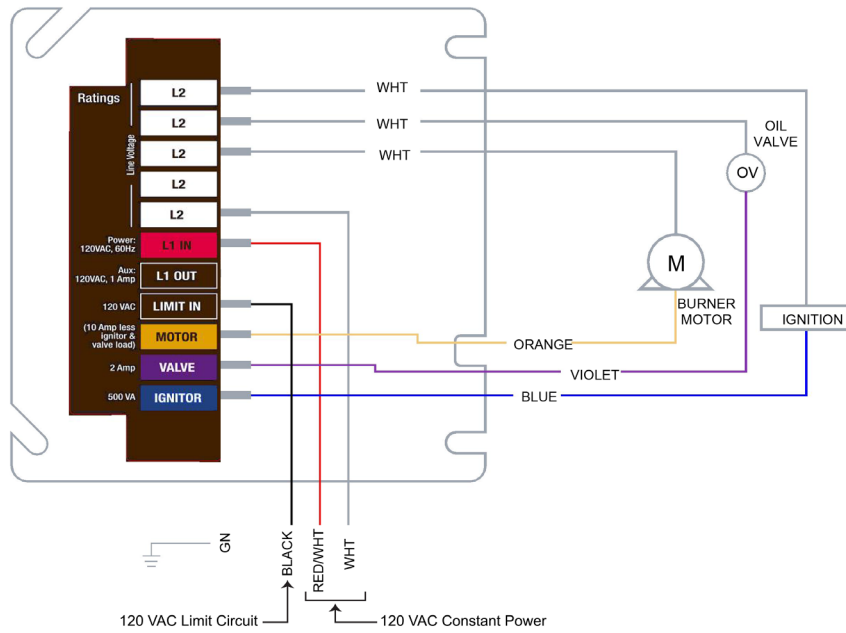

3-Wire Replacement Wiring

NOTICE When connecting to BLACK power harness wire, without constant L1 power, wire nut together L1 (RED) and Limit In (BLACK) from control.

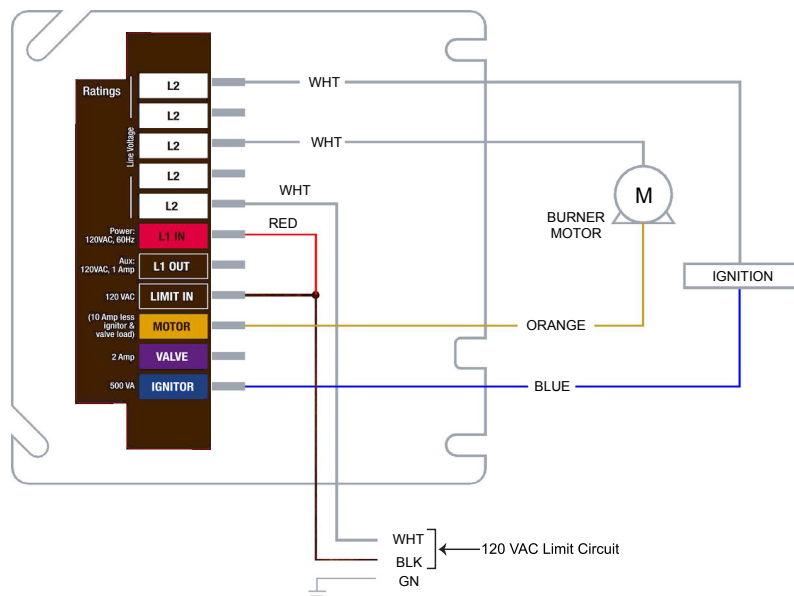

Low Voltage Wiring

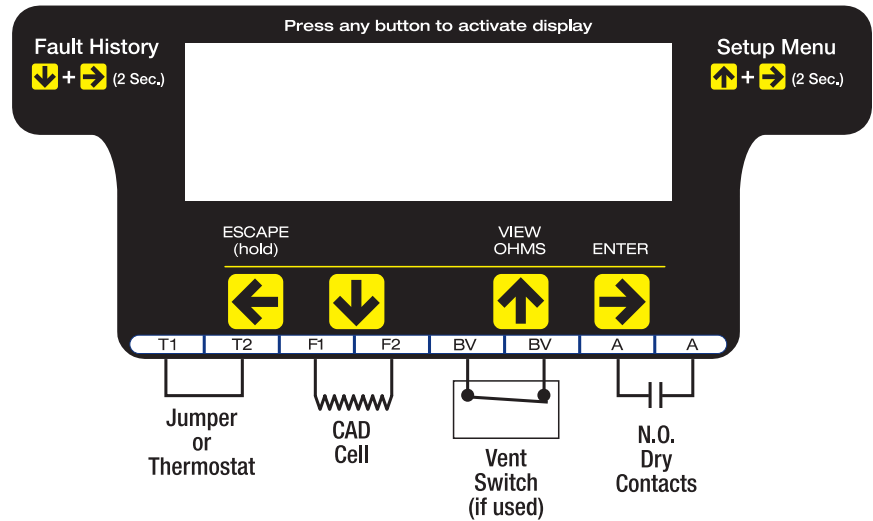

How to Adjust the Combustion Head

The retention ring position ahead of the throttle ring is adjustable from the zero (flush) to $1\frac{1}{8}$ inches (Dimension "A", Figs. 8 and 9). Turning the adjustable screw in (clockwise) increases the distance "A" ahead. This distance is indicated by reading the scale of the nozzle line across the corners on sides of the channel guiding the nozzle line. Each division is $1/16$ inch.

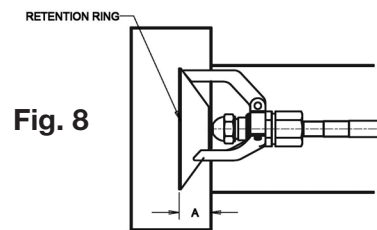

Fig. 8

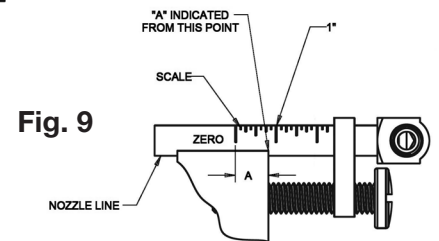

Fig. 9

Retention Ring and Air Shutter Adjustments

Table 2 shows for each firing rate the approximate recommended positions of the flame retention ring with the corresponding amount of air shutter opening. Table 2 is provided as a guide only. Final adjustments must be made using a combustion analyzer.

Table 2. Approximate Settings for Model 601CRD (6 $\frac{1}{4}$ " x 4" Blower Wheel)

| Nozzle Size | Firing Rate (GPH) at 150 psi | Retention Ring Setting, Inches on Scale, Dimension "A" | Initial Air Shutter Opening (percent) |
|-------------|------------------------------|--|---------------------------------------|
| 5.00 | 6.00 | 1/8 | 35 |
| 5.50 | 6.60 | 3/16 | 45 |
| 6.00 | 7.20 | 1/4 | 50 |
| 6.50 | 7.80 | 5/16 | 55 |
| 7.00 | 8.40 | 3/8 | 60 |
| 7.50 | 9.00 | 7/16 | 65 |
| 8.00 | 9.60 | 1/2 | 70 |
| 8.50 | 10.20 | 9/16 | 85 |
| 9.00 | 10.80 | 5/8 | 100 |
| 9.50 | 11.40 | 3/4 | 100 |
| 10.00 | 12.00 | 7/8 | 100 |
| 11.00 | 13.20 | 1 $\frac{1}{4}$ | 100 |

Nozzle Specifications: 45° Semi-Solid or 45° Hollow

45° hollow cone nozzles provide approximately 10% shorter flame than 45° semi-solid nozzles.

Other nozzle configurations may not prove satisfactory.

Always use the nozzle size and spray pattern recommended by Carlin.

Fuel Units and Oil Lines

Standard burners are provided with a two-stage 3450 rpm fuel unit set at 150 psi.

A *single-pipe system* is recommended whenever the bottom of the fuel tank is above the burner or is at the same level as the burner. This includes outdoor fuel tanks that are at such levels.

A *two-pipe system* is recommended when the fuel tank is below the level of the burner, and the fuel unit must pull (lift) the fuel up to the burner. For two-pipe installations, the by-pass plug must be installed. Maximum recommended vacuum is 12 inches of mercury.

Table 3 shows, for the standard two-stage fuel unit, the allowable lift and lengths of 1/2" and 5/8" OD tubing for both suction and return lines in two-pipe systems.

Be sure that all oil line connections are absolutely airtight. Check all connections and joints. Flared fittings

are recommended. **Do not use compression fittings or teflon tape.**

Open the air-bleed valve and start the burner. For clean bleed, slip a 3/16" ID hose over the end of the bleed valve and bleed into a container. Continue to bleed for 15 seconds after oil is free of air bubbles. Stop the burner and close the bleed valve.

Table 3. Two-Stage Units – Two Pipe Systems

| Lift (feet) | Length of Tubing (feet) | |
|-------------|-------------------------|---------|
| | 1/2" OD | 5/8" OD |
| 0 | 100 | 100 |
| 2 | 88 | 100 |
| 4 | 78 | 100 |
| 6 | 69 | 100 |
| 8 | 59 | 100 |
| 10 | 49 | 100 |
| 12 | 39 | 100 |
| 14 | 29 | 82 |
| 15 | 24 | 68 |

Light-Off and Adjustment

Before re-starting the burner, preset the air shutter and the retention ring position for the particular firing rate according to Table 2, page 5.

Adjust draft to 0.02 to 0.04 inches W. C. over the fire for natural draft units.

Run a smoke test. Strive for zero or a trace. Each time

further adjustment of air or retention ring is made, reset the draft to 0.02 to 0.04 inches W.C. over the fire.

Check CO₂. This should be set between 11% and 12%.

Check for good ignition and clean cut-off. If cut-off continues to be poor, look for air leaks in the suction line and correct them.

Forced Draft Firing

Due to the back pressure in forced draft units the maximum firing rate of a burner is reduced. The greater the pressure, the lower the maximum GPH capability becomes. Note that the graph at the right stops at 0.30 inches W.C. for Model 601CRD; the maximum recommended back pressure for this model.

The combustion head settings for forced draft firing would be somewhat greater than those shown in Table 2, page 5, which are for zero pressure or natural draft.

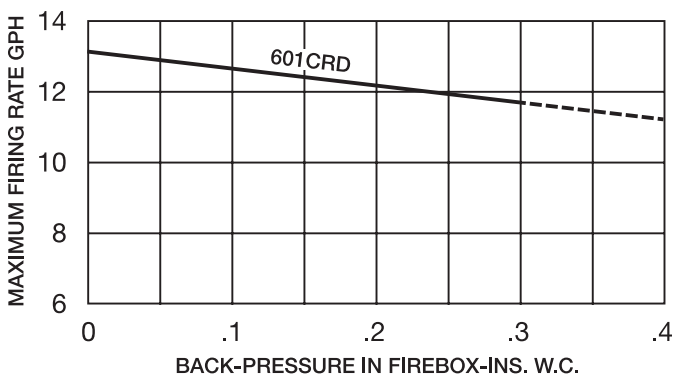

Replacement Parts – 601CRD

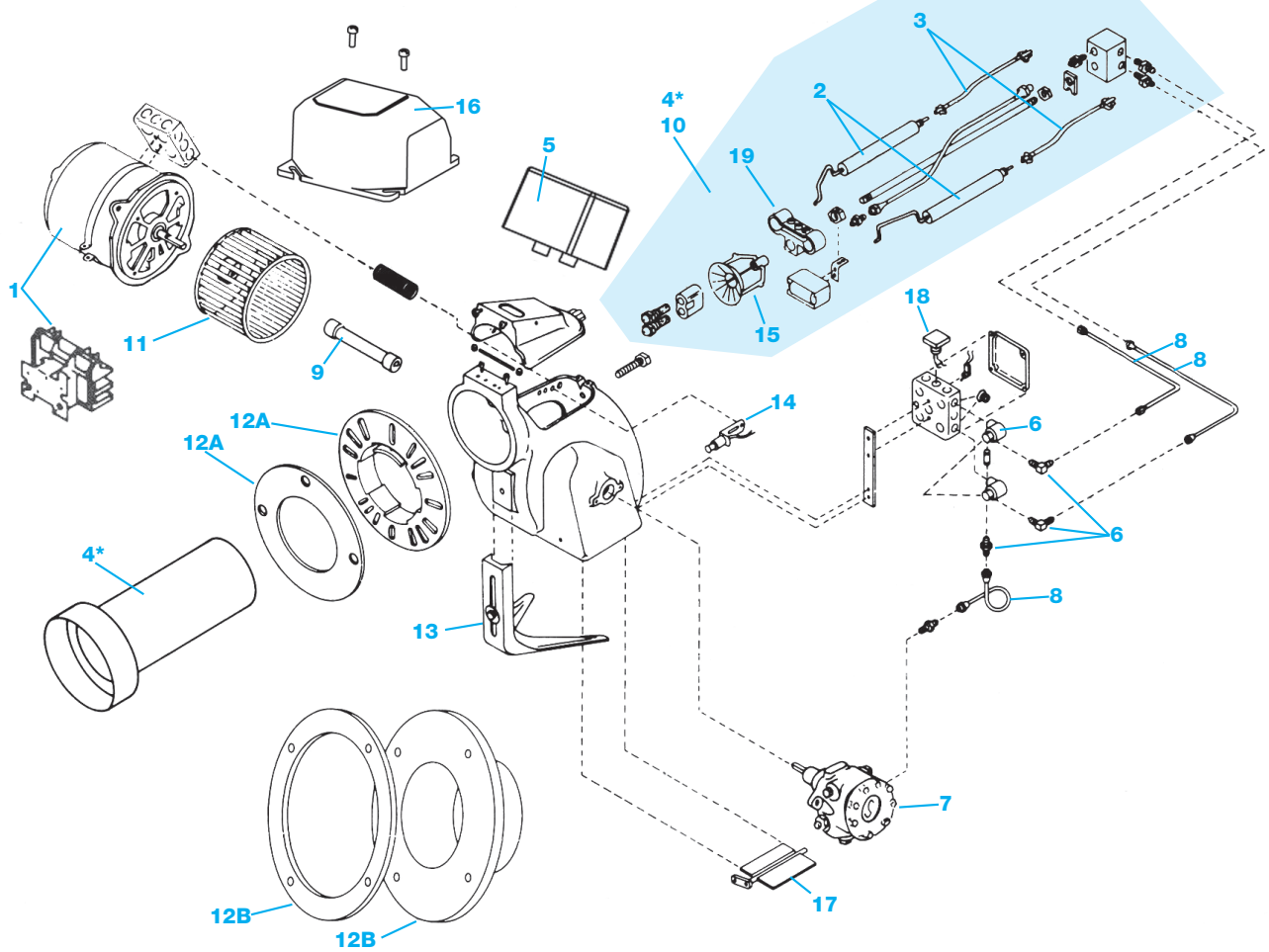

| ITEM | PART NO. | DESCRIPTION |
|------|-----------|--|
| 1 | 27706S | 1/2 hp, 115/230V, 60HZ, 1 Phase, 3450 rpm Motor |
| | 35824S | Motor Contactor 20 AMP R4242B1005 |
| 2 | 98507S | Electrode Set (2), Approx. 9-1/4" OAL |
| 3 | 56069S | Ignition Wire 9-1/4" OAL, for Nominal 12" Air Tube (2 req'd) |
| | 56036S | Ignition Wire 10-3/4" OAL for Nominal 14" Air Tube (2 req'd) |
| | 56085S | Ignition Wire 8-3/8" OAL, for Nominal 10" Air Tube (2 req'd) |
| 4 | 22517S | 601CRD 10" Standard Air Tube/Combustion Head Assy |
| | 22541S | 601CRD 12" Standard Air Tube/Combustion Head Assy |
| | 22574S | 601CRD 14" Standard Air Tube/Combustion Head Assy |
| 5 | 41000S | 110V Ignitor |
| | 41000SOLC | 110V Ignitor on Baseplate |
| 6 | 40857S | Instant Oil Valve 32Z0071TSCV |
| | 61150KITS | Oil Valve Fitting Kit (44560, 29678, 44461, 29728, 44545) |
| 7 | 74450S | Fuel Unit, 2 Stage, NYC, J4PB-B1000G |
| | 98042S | Fuel Unit, 2 Stage, B2TA-8260 |
| | 98127S | Fuel Unit, 2 Stage, NYC, B2TA-8260 |
| 8 | 75291S | Oil line kit |
| 9 | 28738S | Coupling 1/2" ID x 7/16" ID x 4 7/8" L, H or J Pump |
| | 28761S | Coupling 1/2" ID x 5/16" ID x 6 11/32" L, B Pump |

| ITEM | PART NO. | DESCRIPTION |
|------|-----------|--|
| 10 | 56416S | 10" Nominal 20-3/4" OAL Combustion Head Assy |
| | 56440S | 12" Nominal 22-3/4" OAL Combustion Head Assy |
| | 56473S | 14" Nominal 24-3/4" OAL Combustion Head Assy |
| 11 | 98857S | Blower Wheel Only, 6 1/2" OD x 3 3/4" W, 1/2" Bore |
| | 98857KITS | Blower Wheel, Coupling, Augmentor, 6-1/2" OD x 3-3/4" W, 1/2" Bore |
| 12A | 23259S | 4" Universal Flange & Gasket |
| 12B | 23184S | 4" Pressure Flange & Gasket |
| 12C | 59444UVS | 4" Pressure Flange & Gasket – Ultra Violet (not shown) |
| 13 | 23382S | Pedestal w/ hardware |
| 14 | 14407S0ES | CAD Cell Kit |
| 15 | 56580S | Retention Ring Assy 601CRD |
| 16 | 70200S | Universal Primary w/ Display 70200 |
| | 4020002S | Model 40200 Primary 30/15/30 |
| | 5020002S | Model 50200 Primary 30/15/30 |
| | 6020002S | Model 60200 Primary 15/15/15 |
| 17 | 47407S | Air Shutter Assembly |
| 18 | 6702KITS | Hardware Kit (54916, 29694, 47167, 29892, 29728) |
| 19 | 59881S | Electrode Bracket |
| 20 | 35741S | 4 Second Time Delay |

Carlin®

Combustion Technology



601CRD Burner User Care and Maintenance

WARNING Refer only to the information on this page, intended for your use. The remainder of this manual is intended only for your service technician. Failure to comply could result in severe personal injury, death or substantial property damage.

For other than routine maintenance, contact a qualified service company. Perform the following as needed.

- Keep the area around the burner clear and free from combustible vapors and liquids.
- Do not obstruct the flow of combustion and ventilating air.
- Most motors currently used on residential type burners use permanently-lubricated bearings, and do not require field lubrication. Read the label on the motor to determine oiling needs, if any. Do not over-lubricate. This can cause as much trouble as not lubricating at all.

WARNING The burner must be cleaned, tested and adjusted annually by a qualified oil burner service technician.

WARNING **Should overheating occur:**

1. Shut off the oil supply to the burner.
2. **DO NOT** shut off the control switch to the circulator or blower.
3. Contact your oil dealer or service technician and the fire department (if needed).

WARNING Never attempt to use gasoline as a fuel for this burner, as it is more combustible and could result in a serious explosion. Never attempt to burn refuse or use any fuel other than #1 or #2 heating oil or bio blends not exceeding B20 (U.S. Only) (ASTM D396).