

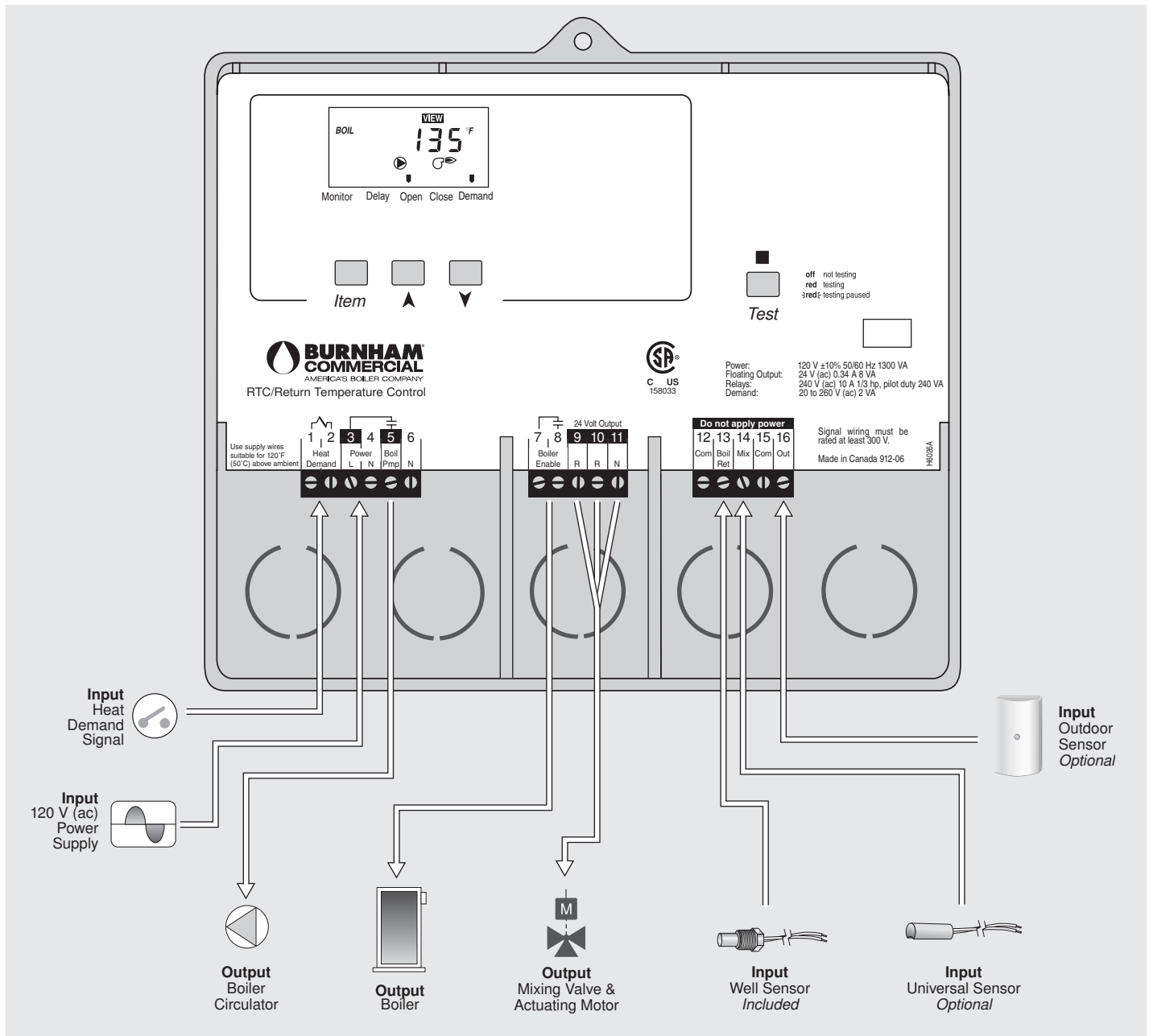

The Burnham Return Temperature Control (RTC) is designed to operate a 3-way or a 4-way valve to protect the boiler against flue gas condensation and thermal shock. The RTC can also optionally control the supply water temperature to the system based on a setpoint temperature or an outdoor reset strategy. A boiler post purge is provided by keeping the boiler recirculating pump running after the call for heat is removed.

Additional functions include:

- Counts boiler run time
- Counts the number of boiler cycles
- Counts boiler cold shocks
- Warns of cold boiler return temperatures
- Test sequence to ensure proper operation
- CSA C US certified



How To Use This Manual

This manual is organized into four main sections. They are: 1) *Sequence of Operation*, 2) *Installation*, 3) *Control Settings*, and 4) *Testing and Troubleshooting*. The Sequence of Operation section has four sub-sections. We recommend reading Section A: General Operation of the Sequence of Operation section, as this contains important information on the overall operation of the control. Then read the sub sections that apply to your installation.

The Control Settings section of this manual describes the various items that are adjusted and displayed by the control. The control functions of each adjustable item are described in the Sequence of Operation.

Table of Contents

User Interface.....Pg 2	Testing the Control.....Pg 22
DisplayPg 3	TroubleshootingPg 22
Sequence of Operation.....Pg 3	Error Messages.....Pg 23
<i>Section A: General Operation.....Pg 3</i>	Repair PartsPg 24
<i>Section B: Control Operation.....Pg 4</i>	Appendix A: Mechanical And Electrical Application Drawings.....Pg 25
<i>Section C: Control Settings.....Pg 5</i>	Appendix B: Boiler Circulator And Diverting Valve Selection Charts.....Pg 46
<i>Section D: Temperature MonitoringPg 6</i>	Appendix C: Valve And Actuator Mounting Instructions.....Pg 58
Installation.....Pg 7	Technical Data.....Pg 60
Control Settings.....Pg 20	Limited WarrantyPg 60
<i>View MenuPg 20</i>	
<i>Adjust MenuPg 21</i>	

User Interface

The control uses a Liquid Crystal Display (LCD) as the method of supplying information. The LCD is used in order to setup and monitor the operation of the system. The control has three push buttons (*Item*, ▲, ▼) for selecting and adjusting settings. As the control is programmed, record the settings in the Adjust menu table, which is found in the second half of this manual.

Item

The abbreviated name of the selected item will be displayed in the item field of the display. To view the next available item, press and release the *Item* button. Once the last available item in a menu has been reached, pressing and releasing the *Item* button will return the display to the first item in the selected menu.



Adjust

To make an adjustment to a setting in the control, press all 3 buttons for 1 second (the *Item*, ▲ and ▼ buttons). The display will then show the word ADJUST in the top right corner. Then select the desired item using the *Item* button. Finally, use the ▲ and/or ▼ button to make the adjustment.



To exit the ADJUST menu, leave the adjustment buttons alone for 20 seconds.

When the *Item* button is pressed and held in the VIEW menu, the display scrolls through all the adjust items.

Additional information can be gained by observing the status field and pointers of the LCD. The status field will indicate which of the control's outputs are currently active. Most symbols in the status field are only visible when the VIEW menu is selected.

Display

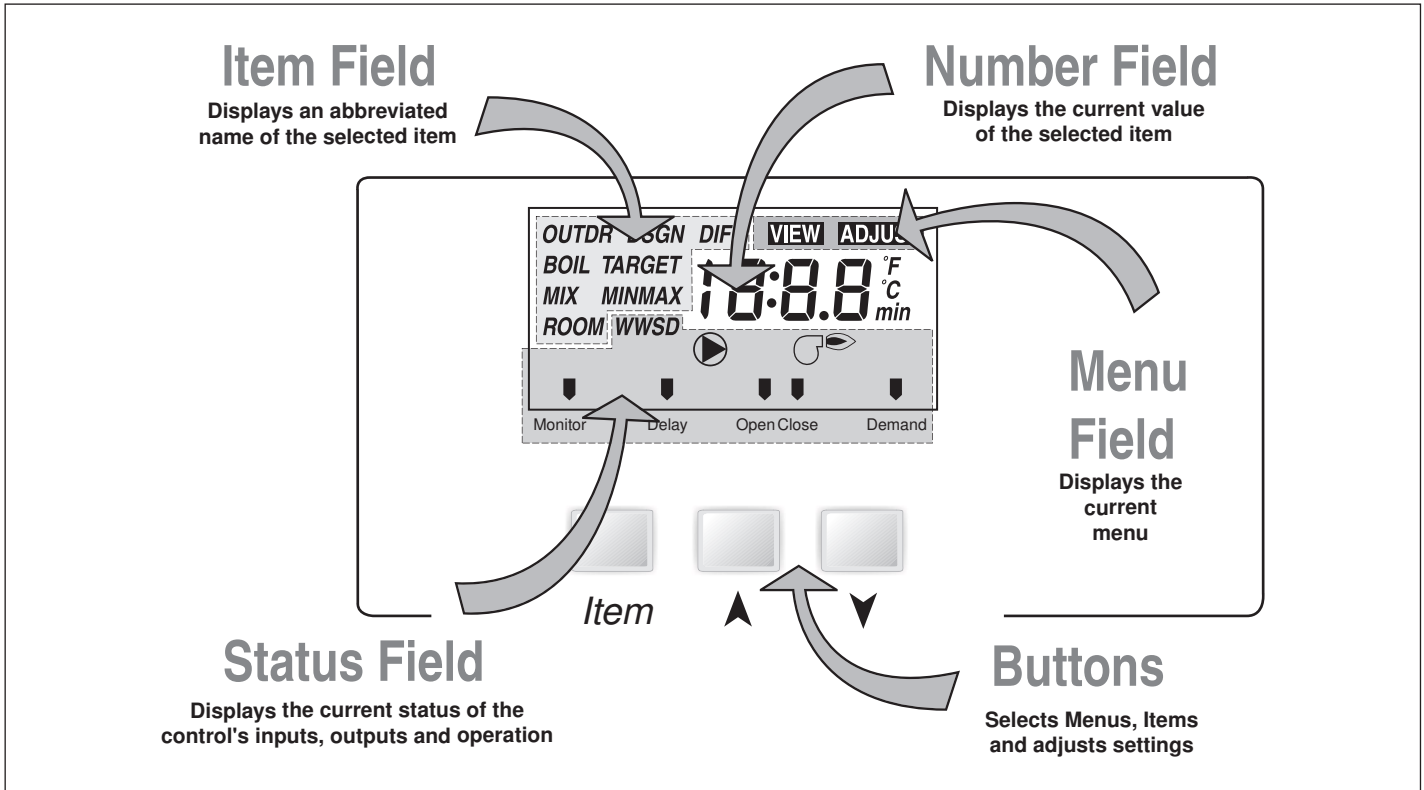

Symbol Description

	Pump Displays when the boiler recirculating pump is in operation.	°F, °C °F °C Displays the unit of measure that all of the temperatures are to be displayed in the control.
	Burner Displays when the boiler relay is turned on.	

Sequence of Operation

Section A General Operation Page 3 - 4	Section B Control Operation Page 4 - 5	Section C Control Settings Page 5 - 6	Section D Temperature Monitoring Page 6
--	--	---	---

Section A: General Operation

POWERING UP THE CONTROL

When the control is powered up with 120 V (ac), the control displays "rtc" for 2 seconds followed by the software version for 2 seconds. The control then enters the normal operating mode

OPERATION

The control operates a floating action actuator motor connected to a 3-way or 4-way valve to control the boiler return water temperature to prevent flue gas condensation and thermal shock. The control can also be used to provide outdoor reset or a fixed setpoint temperature to the supply water temperature.

Outdoor Reset

When the outdoor design (OUTDR DSGN) setting is set to a temperature, the control calculates a mix supply temperature based on the outdoor air temperature and the programmed reset ratio. An outdoor sensor and a mix supply sensor must be installed.

Setpoint Control

When the outdoor design (OUTDR DSGN) setting is set to OFF, and there is a mix supply sensor installed, the control supplies a fixed mix supply temperature equal to the MIX TARGET setting. An outdoor sensor is not required during this mode of operation.

No Diverting Valve

If a diverting valve is not installed, the outdoor design (OUTDR DSGN) is set to OFF. The boiler return sensor must be installed to provide monitoring of the boiler conditions.

Floating Action

A 24 V (ac) floating action actuator motor is connected directly to the control on the *R*, *R* and *N* terminals (9, 10 and 11). The *R* on terminal 9 is used to open the 3-way diverting valve to the system. The valve can open either in the clockwise or the counterclockwise direction depending on the orientation of the valve. The *R* on terminal 10 is used to close the valve. The control pulses the actuating motor to open or close to maintain the correct mixed supply water temperature at the mix sensor when there is a heat demand. A visual indication as to whether the control is currently opening or closing the 3-way diverting valve is displayed in the LCD.

Boiler Protection

The control is capable of providing boiler protection from cold return water temperatures. If the boiler sensor temperature is cooler than the BOIL MIN setting while the boiler is firing, the control reduces the output to the 3-way diverting valve. This limits the amount of cool return water to the boiler and allows the boiler temperature to recover. This feature can only be used if a 3-way diverting valve is installed.

Exercising

The control has a built-in exercising function. If the boiler recirculating pump or valve has not been operated at least once every 3 days, the control turns on the output for a minimum of 10 seconds. This minimizes the possibility of a pump or valve seizing during a long period of inactivity. The control ensures that the diverting valve operates over its entire range at least once each exercising period. While the control is exercising, the Test LED flashes.

Note: The exercising function does not work if power to the control, pump, or valve is disconnected.

Section B: Control Operation

HEAT DEMAND

A heat demand is required in order for the control to provide heat by firing the boiler and opening the 3-way diverting valve. To generate a heat demand, apply between 24 and 240 V (ac) across the *Heat Demand* terminals (1 and 2). Once voltage is applied, the *Demand* pointer is displayed in the LCD.

When the heat demand is removed, the 3-way diverting valve is fully closed before the control is allowed to register a new heat demand. The *Demand* pointer will be displayed whenever voltage is present on the *Heat Demand* terminals, even if the heat demand is not registered. The 3-way diverting valve is closed to ensure the boiler is protected in the next boiler cycle.

Optionally, the control can be set up to target a setpoint mix supply temperature or outdoor reset temperature through the diverting valve.

OUTDOOR RESET RATIO

When the control is used as a mixing reset control, the control uses an outdoor sensor to measure the outdoor temperature. The reset ratio increases the mix water temperature for every degree the outdoor temperature falls. The slope of the reset ratio determines the rate at which the temperature increases with falling outdoor temperatures. The reset ratio is adjustable using the mix design (MIX DSGN) and the outdoor design (OUTDR DSGN) settings.

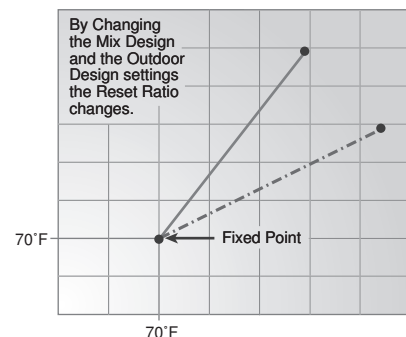

MIX TARGET

When used as a mixing reset control, the MIX TARGET temperature is calculated from the reset ratio and outdoor air temperature. When used as a setpoint control, the installer sets the MIX TARGET temperature. The control displays the temperature that it is currently trying to maintain as the mix supply temperature. If the control does not have a heat demand, “--” is displayed as the MIX TARGET.

BOILER RECIRCULATING PUMP

The boiler recirculating pump contact (*Boil Pmp*, terminal 5) closes whenever there is a registered heat demand and the control is not in warm weather shut down (WWSD). The boiler recirculating pump segment is displayed in the LCD. When the heat demand is satisfied, the control continues to operate the boiler recirculating pump for the purge time. The diverting valve remains open at the current setting during the purge time and will modulate to protect the boiler. Once the purge time has expired, the boiler recirculating pump shuts off and the valve closes. If at any time the boiler return temperature falls below 135°F (57°C), the purge is canceled. During the WWSD, the control exercises the pump for 10 seconds every 3 days of no activity.

Section C: Control Settings

OUTDOOR RESET SETTINGS

Note: For single boiler installations only. When multiple boilers are installed, use an appropriate staging control for outdoor reset functions.

Room

The ROOM setting is the desired room temperature in the heating zone. The ROOM setting provides a method to parallel shift the reset ratio so that higher (or lower) mix water target temperatures are available over the entire reset range. Adjusting the ROOM setting increases or decreases the heat delivery to the building.

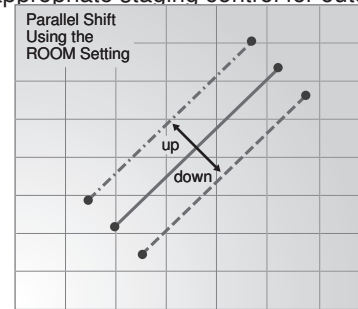

Mixing Design (MIX DSGN)

The MIX DSGN temperature is the supply water temperature required to heat the mixing zones when the outdoor air temperature is as cold as the OUTDR DSGN Setting.

Outdoor Design (OUTDR DSGN)

The OUTDR DSGN is the outdoor air temperature that is the typical coldest temperature of the year where the building is located. This temperature is used when doing the heat loss calculations for the building. If a cold outdoor design temperature is selected, the mix supply temperature rises gradually as the outdoor temperature drops. If a warm outdoor design temperature is selected, the mix supply temperature rises rapidly as the outdoor temperature drops.

Warm Weather Shut Down (WWSD)

When the outdoor air temperature rises above the WWSD setting, the control turns on the WWSD segment in the display. When the control is in WWSD, the Demand pointer is displayed, if there is a demand. However, the control does not operate the heating system to satisfy this demand. If the control is in setpoint mode, the WWSD feature is not functional.

Mixing Minimum (MIX MIN)

The MIX MIN is the lowest temperature that the control is allowed to use as a mix target temperature. During mild conditions, if the control calculates a mix target temperature that is below the MIX MIN setting, the mix target temperature is adjusted to match the MIX MIN setting. During this condition, the MIN segment will be displayed in the LCD when either the MIX TARGET or MIX temperature is being viewed.

Mixing Maximum (MIX MAX)

The MIX MAX sets the highest water temperature that the control is allowed to calculate as the mix target temperature. If the control does target the MIX MAX setting, and the MIX temperature is near the MIX MAX, the MAX segment will be displayed in the LCD while either the MIX TARGET temperature or the MIX temperature is being viewed.

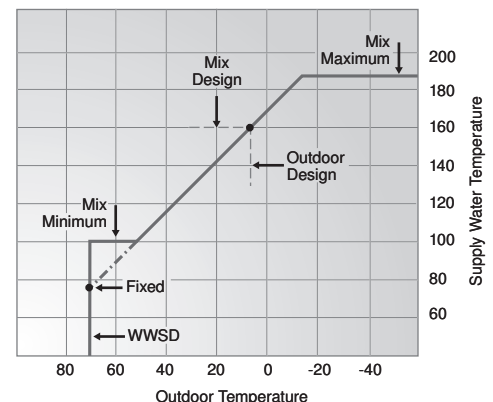

SETPOINT OPERATION

Mix Target

For setpoint control, set the OUTDR DSGN to OFF. The mix target becomes the setpoint supply temperature that the control is to maintain. The mix target temperature is set by the installer in the ADJUST menu. An outdoor sensor is not required during this mode of operation.

COMMON SETTINGS

The following settings are common to both the outdoor reset and setpoint operations.

Open Delay

The open delay is the amount of time that the actuating motor requires to operate the valve from fully closed to fully open.

Boiler Minimum (BOIL MIN)

Most boilers require a minimum water temperature in order to prevent flue gas condensation. The BOIL MIN adjustment is set to the boiler's minimum recommended operating temperature. The lowest boiler minimum temperature is 135°F (57°C).

Boiler Minimum Delay (BOIL MIN Delay)

The boiler minimum delay allows a time for the boiler temperature to rise to the boiler minimum temperature while there is a heat demand. After the time delay, the control begins to count the boiler minimum run time (Monitor BOIL MIN run).

Pump Delay

The pump delay allows the boiler recirculating pump to purge heat from the boiler into the system after the heat demand is removed. The amount of purge time is determined by the Pump Delay setting.

Section D: Temperature Monitoring

Boiler Temperature (BOIL)

The actual boiler return temperature as measured by the boiler return sensor.

Mix Target

The current mix target temperature if outdoor reset or setpoint operation is selected.

Mix

The actual mix temperature as measured by the mix supply sensor if a mix supply sensor is installed.

Outdoor

The current outdoor temperature as measured by the outdoor sensor, if the outdoor sensor is installed and Outdoor Design is set to a temperature.

Monitor Items

Monitor Items are displayed using a five digit number. The display cycles between the monitor name, the first two digits, and the last three digits.

Boiler Run Time (Monitor BOIL run)

The control records the number of hours the boiler enable contact has been closed.

Number of Boiler Cycles (Monitor BOIL CYC)

The control records the number of cycles of the boiler enable contact.

Boiler Run Time Below Return Water Minimum (Monitor BOIL MIN run)

The control records the number of hours the boiler return temperature is below the boiler minimum temperature and the boiler enable contact is closed. The control does not record any time while the control is within the boiler minimum delay period.

Number of Boiler Cold Shock Conditions (Monitor BOIL CS)

The control records the number of large and quick temperature swings, which could be an indication of erratic system behavior.

Boiler Sensor Error Time (Monitor BOIL MIN Err)

The control records the number of hours the boiler return sensor is not functioning.

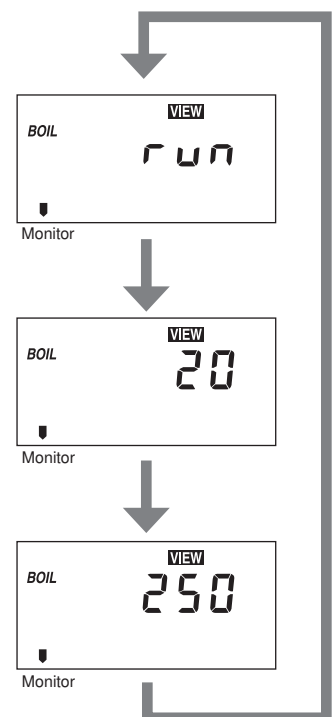

Caution

Improper installation and operation of this control could result in damage to the equipment and possibly even personal injury. It is the installer's responsibility to ensure that this control is safely installed according to all applicable codes and standards. This electronic control is not intended for uses as a primary limit control. Other controls that are intended and certified as safety limits must be placed into the control circuit. Do not open the control. Refer to qualified personnel for servicing. Opening voids warranty and could result in damage to the equipment and possibly even personal injury.

STEP ONE — GETTING READY

Check the contents of this package. If any of the contents listed are missing or damaged, please contact your wholesaler or Burnham representative for assistance.

Burnham RTC includes: Burnham Return Temperature Control, Return Temperature Control manual, 1 boiler return sensor, 4 #8-32 x 1/2" Phillips screws.

STEP TWO — INSTALLING THE CONTROL AND RELATED COMPONENTS

A. Return Temperature Control (RTC) – Mount the control to the boiler front jacket panel at the top right. See Figures 1 and 2 for general component placement. The RTC mounting bracket must be attached to the jacket first, using four (4) #8 x 3/4" drill point sheet metal screws. Before attaching the RTC to the mounting bracket, remove the controller from the control base/wiring chamber by pressing the tab on the base and pulling the controller up and off. (This is to prevent accidental damage to the controller during the mounting process.) One may find it easier to install some of the conduit connectors, along with their corresponding conduit runs, onto the RTC control base/wiring chamber before mounting it to the bracket. Before choosing which wiring knockouts to use, read Step Four. Mount the control base/wiring chamber to the bracket using the four (4) #8-32 x 1/2" Phillips pan head screws supplied with the RTC. Then reattach the RTC controller to the control base.

B. Return Sensor – The return water temperature sensor must be mounted in a special 3"NPT x 12" long nipple with 1/4" NPT side tapping supplied by Burnham. Apply pipe dope to special nipple both threaded ends and mount the nipple into the boiler's right rear return port (as viewed from the rear of the boiler), so that nipple side tapping end is positioned away from the boiler. Apply pipe dope to the sensor threads and install the sensor into the nipple 1/4" NPT side tapping making sure the connection is watertight. Use bell reducer (refer to Figure 3 or Figure 4) to adapt to recommended return piping size. See Figure 3 or 4 (depending on the boiler being installed) for the proper location of the return nipple. See Figure 2 for return sensor wiring details. Run the sensor wiring to a suitable junction box, using a grommet to protect the leads as they enter the box. Mount the junction box to the boiler's rear jacket panel, as shown in Figure 2. Connect the sensor wiring from the junction box to the RTC control at the front of the boiler, using the appropriate conduit and connectors.

C. Diverting Valve and Actuator – A diverting 3-way or 4-way valve must be installed in the boiler loop piping in order for the RTC to provide boiler protection. Only a Burnham-approved valve and actuator may be used with the RTC. The diverting valve sizing depends upon the designed boiler delta T. See Appendix B for proper valve selection. The valve actuator is mounted to the top of the diverting valve. Position the valve so that the actuator is not on the underside of the valve. Mount and connect the actuator as illustrated in Appendix C. The electrical connections depend on the valve orientation.

D. Boiler Circulator – A properly selected boiler circulator will maintain a constant and minimum flow through the boiler during each heat demand. The appropriate circulator must be selected, based upon the designed boiler delta T. See Appendix B for appropriate boiler circulator selections for 20°F and 40°F delta T applications.

WARNING: IF THE SELECTED BOILER CIRCULATOR IS GREATER THAN 1/3 HP, AN ISOLATION RELAY MUST BE ADDED WHEN USING THE RTC. IF A 3-PHASE BOILER CIRCULATOR OR A CIRCULATOR WITH AN AMP DRAW GREATER THAN 10 AMP IS SELECTED, AN APPROPRIATE MOTOR STARTER MUST BE USED.

STEP THREE — NEAR BOILER PIPING

When using the RTC control, the boiler loop piping must contain the boiler, the boiler circulator, a 3-way or 4-way diverting valve, and the return sensor. The boiler loop injects hot water into the primary loop, provided that the boiler return water temperature (measured by the return sensor) is at least 135°F. If the return temperature is below 135°F, the diverting valve closes, recirculating boiler supply water through the boiler loop until the return water has been heated to at least 135°F. The RTC controls the diverting valve actuator based upon the absolute return water temperature, as well as the rate of temperature change.

Several typical RTC applications are shown in Appendix A. Select the appropriate application before proceeding.

See Figures 5 and 6 for general component and piping arrangements when using 3-way and 4-way diverting valves. See Figure 3 for V9A piping recommendations for 3-way valve applications. See Figure 4 for V11 piping recommendations for 3-way valve applications. As shown in these diagrams, the boiler loop's supply and return are connected to the primary loop through two closely spaced tees, at a maximum branch centerline distance of four times the primary loop diameter (4 x D Max).

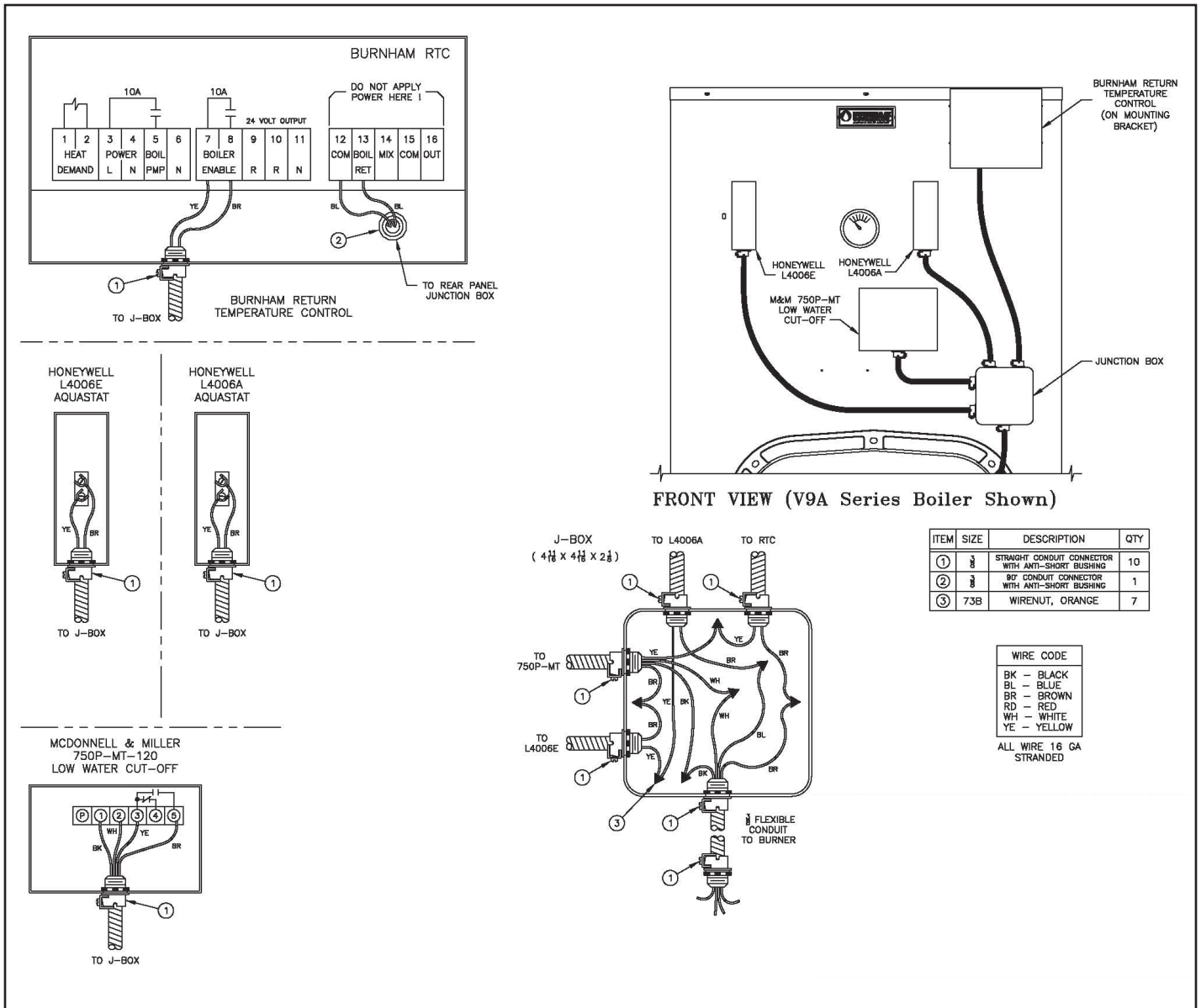

Figure 1: Typical Boiler Wiring With RTC (Front)

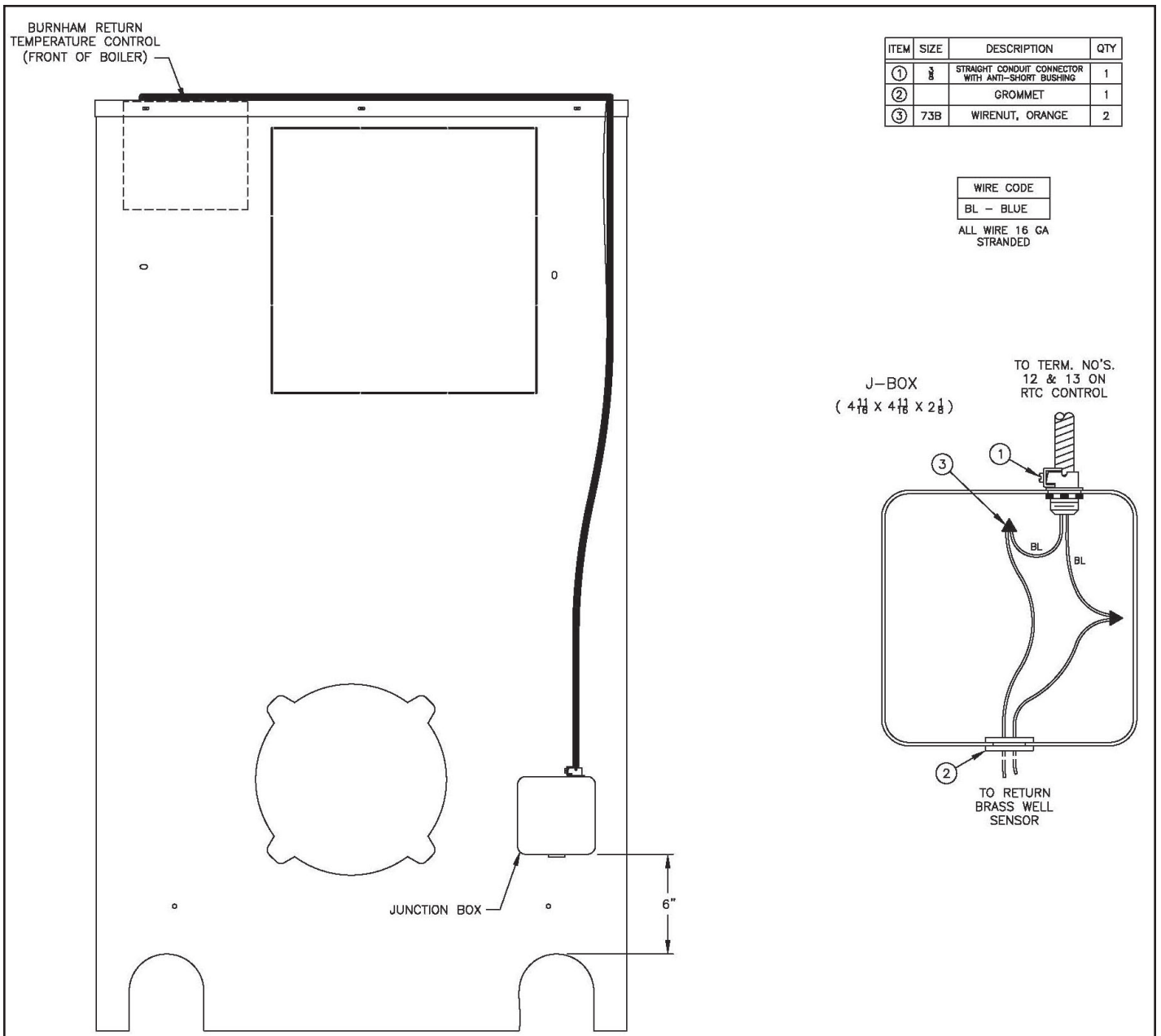
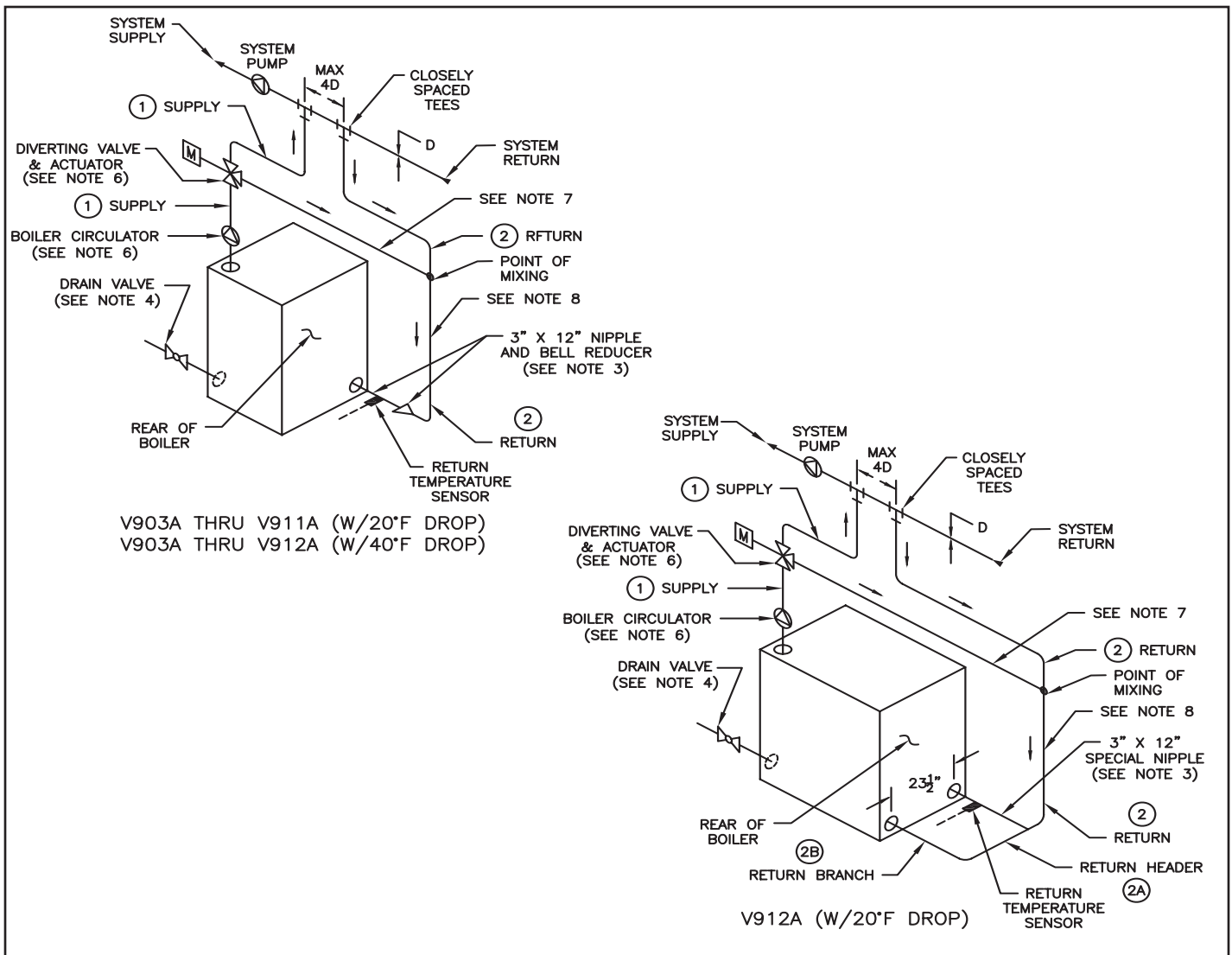

Figure 2: Typical Boiler Wiring With RTC Return Sensor (Rear)



MODEL	SUPPLY PIPING SIZE		RETURN AND BYPASS PIPING SIZE			
			RETURN		RETURN HEADER	RETURN BRANCH (QTY) SIZE
	20°F DROP	40°F DROP	20°F DROP	40°F DROP	20°F DROP	20°F DROP
V903A	2"	1½"	2"	1½"	--	--
V904A	2"	1½"	2"	1½"	--	--
V905A	2"	1½"	2"	1½"	--	--
V906A	2½"	1½"	2½"	1½"	--	--
V907A	2½"	2"	2½"	2"	--	--
V908A	2½"	2"	2½"	2"	--	--
V909A	3"	2"	3"	2"	--	--
V910A	3"	2½"	3"	2½"	--	--
V911A	3"	2½"	3"	2½"	--	--
V912A	4"	2½"	4"	2½"	3"	(2) 3"

NOTES:

1. ALL SUPPLY AND RETURN PIPING IS SCHEDULE 40 BLACK PIPE.
2. PIPE SIZES LISTED IN TABLE ARE BASED ON EITHER A 20°F OR A 40°F TEMPERATURE DROP DIFFERENTIAL. SELECT ONE DIFFERENTIAL THAT MATCHES THE APPLICATION.
3. INSTALL SPECIAL 3" NPT X 12" LG. X ¼" NPT SIDE TAPPING PIPE NIPPLE INTO BOILER RETURN PORT WITH SIDE TAPPING NIPPLE END POSITIONED AWAY FROM BOILER. USE BELL REDUCER FOR MODELS V903A THRU V911A (WITH A 20°F TEMPERATURE DROP), OR, FOR MODELS V903A THRU V911A (WITH A 40°F TEMPERATURE DROP) TO ADAPT TO RECOMMENDED RETURN PIPING SIZE (SEE TABLE).
4. DRAIN VALVE (ALTERNATE BALL VALVE IS PREFERABLE, ALTERNATE GATE VALVE IS ACCEPTABLE)— MINIMUM VALVE SIZE IS ¾" NPT PER ASME CODE.
5. ALL PIPE REDUCTIONS SHALL BE MADE ONLY AT THE BOILER SUPPLY AND RETURN TAPINGS AND/OR DIVERTING VALVE AND BOILER CIRCULATOR FLANGES UNLESS NOTED OTHERWISE.
6. SEE APPENDIX B FOR BOILER CIRCULATOR AND DIVERTING VALVE SELECTION AND PART NUMBERS.
7. MAXIMUM LINEAR DISTANCE, FEET OF PIPE, FROM 3-WAY DIVERTING VALVE BYPASS PORT TO RETURN TEMPERATURE SENSOR LOCATION IS EQUAL TO 11 (ELEVEN) FEET. BYPASS LINE SHALL BE THE SAME DIAMETER AS RETURN PIPE ②.
8. MINIMUM LINEAR DISTANCE, FEET OF PIPE, FROM POINT OF MIXING (WHERE BYPASS FLOW MEETS RETURN FLOW) TO RETURN TEMPERATURE SENSOR LOCATION IS EQUAL TO 4 (FOUR) FEET.
9. USE THESE PIPING ARRANGEMENTS FOR APPLICATIONS WHERE THE SYSTEM RETURN TEMPERATURE IS NOT LOWER THAN 135°F FOR PROLONGED PERIODS OF TIME.

**Figure 3: V9A Series Boiler Recommended Minimum Piping
- RTC With 3-Way Diverting Valve**

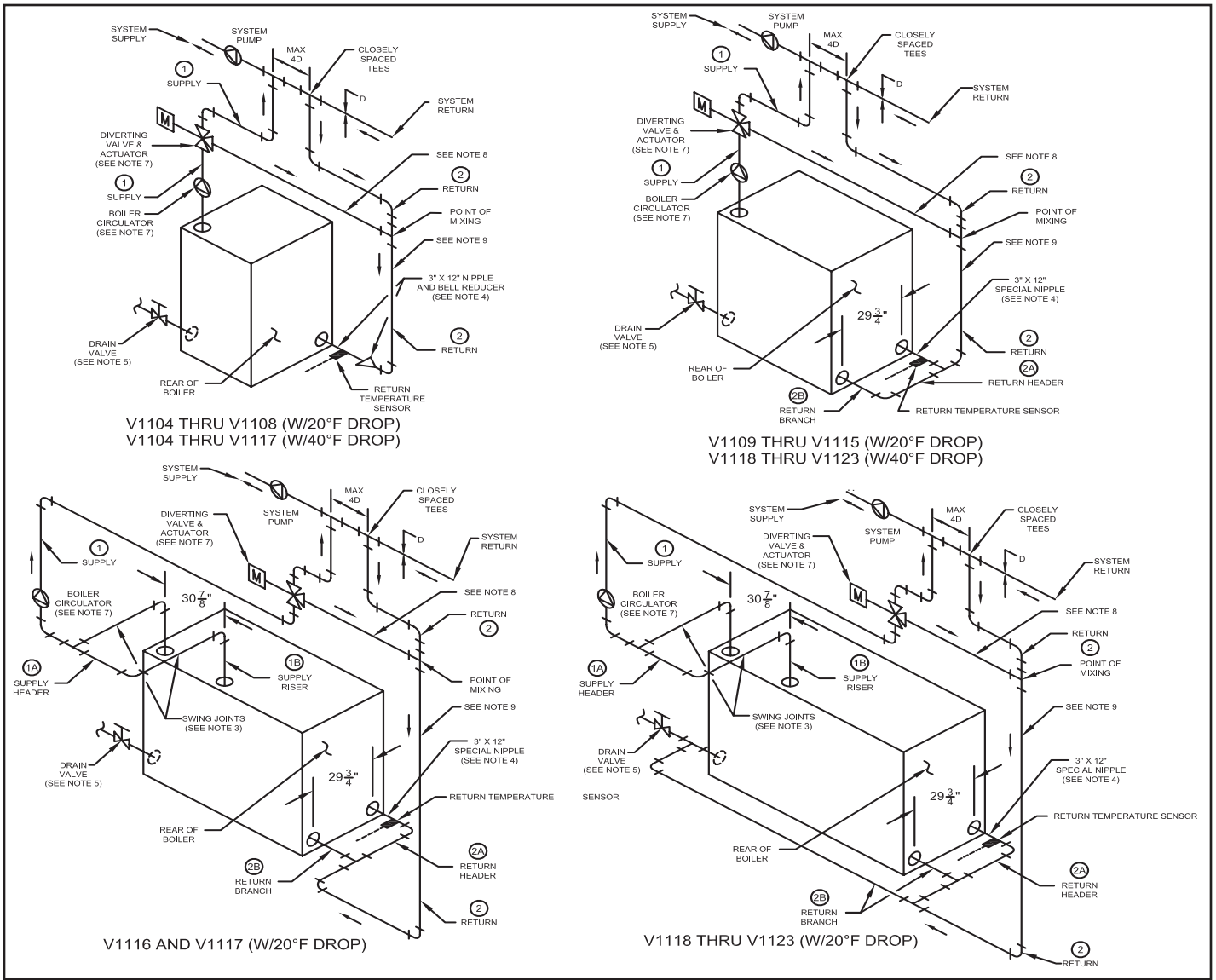

BOILER MODEL	SUPPLY PIPING SIZE						RETURN PIPING SIZE					
	① SUPPLY		①A SUPPLY HEADER		①B SUPPLY RISER (QTY) SIZE		② RETURN		②A RETURN HEADER		②B RETURN BRANCH (QTY) SIZE	
	20°F DROP	40°F DROP	20°F DROP	40°F DROP	20°F DROP	40°F DROP	20°F DROP	40°F DROP	20°F DROP	40°F DROP	20°F DROP	40°F DROP
V1104	2 1/2"	2"	—	—	—	—	2 1/2"	2"	—	—	—	—
V1105	2 1/2"	2"	—	—	—	—	2 1/2"	2"	—	—	—	—
V1106	2 1/2"	2"	—	—	—	—	2 1/2"	2"	—	—	—	—
V1107	3"	2"	—	—	—	—	3"	2"	—	—	—	—
V1108	3"	2"	—	—	—	—	3"	2"	—	—	—	—
V1109	4"	2 1/2"	—	—	—	—	4"	2 1/2"	3"	—	(2) 3"	—
V1110	4"	2 1/2"	—	—	—	—	4"	2 1/2"	3"	—	(2) 3"	—
V1111	4"	2 1/2"	—	—	—	—	4"	2 1/2"	3"	—	(2) 3"	—
V1112	4"	3"	—	—	—	—	4"	3"	3"	—	(2) 3"	—
V1113	4"	3"	—	—	—	—	4"	3"	3"	—	(2) 3"	—
V1114	4"	3"	—	—	—	—	4"	3"	3"	—	(2) 3"	—
V1115	4"	3"	—	—	—	—	4"	3"	3"	—	(2) 3"	—
V1116	5"	3"	3"	—	(2) 3"	—	5"	3"	3"	—	(2) 3"	—
V1117	5"	3"	3"	—	(2) 3"	—	5"	3"	3"	—	(2) 3"	—
V1118	5"	4"	4"	—	(2) 4"	—	5"	4"	4"	3"	(3) 3"	(2) 3"
V1119	5"	4"	4"	—	(2) 4"	—	5"	4"	4"	3"	(3) 3"	(2) 3"
V1120	5"	4"	4"	—	(2) 4"	—	5"	4"	4"	3"	(3) 3"	(2) 3"
V1121	5"	4"	4"	—	(2) 4"	—	5"	4"	5"	3"	(3) 3"	(2) 3"
V1122	5"	4"	4"	—	(2) 4"	—	5"	4"	5"	3"	(3) 3"	(2) 3"
V1123	5"	4"	4"	—	(2) 4"	—	5"	4"	5"	3"	(3) 3"	(2) 3"

- NOTES:**
1. ALL SUPPLY AND RETURN PIPING IS SCHEDULE 40 BLACK PIPE.
 2. PIPE SIZES LISTED IN TABLE ARE BASED ON EITHER A 20°F OR A 40°F TEMPERATURE DROP DIFFERENTIAL. SELECT ONE DIFFERENTIAL THAT MATCHES THE APPLICATION.
 3. SWING JOINTS ON TWO RISER SYSTEMS MAY BE PIPED OVER THE TOP OF THE BOILER IF SPACE IS LIMITED.
 4. INSTALL SPECIAL 3" NPT X 12" LG. X 1/2" NPT SIDE TAPPING PIPE NIPPLE INTO BOILER RETURN PORT WITH SIDE TAPPING NIPPLE END POSITIONED AWAY FROM BOILER. USE BELL REDUCER FOR MODELS V1104 THRU V1108 (WITH A 20°F TEMPERATURE DROP), OR, FOR MODELS V1104 THRU V1117 (WITH A 40°F TEMPERATURE DROP) TO ADAPT TO RECOMMENDED RETURN PIPING SIZE (SEE TABLE).
 5. DRAIN VALVE (ALTERNATE BALL VALVE IS PREFERABLE, ALTERNATE GATE VALVE IS ACCEPTABLE)—MINIMUM VALVE SIZE IS 3/8" NPT PER ASME CODE.
 6. ALL PIPE REDUCTIONS SHALL BE MADE ONLY AT THE BOILER SUPPLY AND RETURN TAPINGS AND/OR DIVERTING VALVE AND BOILER CIRCULATOR FLANGES UNLESS NOTED OTHERWISE.
 7. SEE APPENDIX B FOR BOILER CIRCULATOR AND DIVERTING VALVE SELECTION AND PART NUMBERS.
 8. MAXIMUM LINEAR DISTANCE, FEET OF PIPE, FROM 3-WAY DIVERTING VALVE BYPASS PORT TO RETURN TEMPERATURE SENSOR LOCATION IS EQUAL TO 11 (ELEVEN) FEET. BYPASS LINE SHALL BE THE SAME DIAMETER AS RETURN PIPE ②.
 9. MINIMUM LINEAR DISTANCE, FEET OF PIPE, FROM POINT OF MIXING (WHERE BYPASS FLOW MEETS RETURN FLOW) TO RETURN TEMPERATURE SENSOR LOCATION IS EQUAL TO 4 (FOUR) FEET.
 10. USE THESE PIPING ARRANGEMENTS FOR APPLICATIONS WHERE THE SYSTEM RETURN TEMPERATURE IS NOT LOWER THAN 135°F FOR PROLONGED PERIODS OF TIME.

Figure 4: V11 Series Boiler Recommended Minimum Piping - RTC With 3-Way Diverting Valve

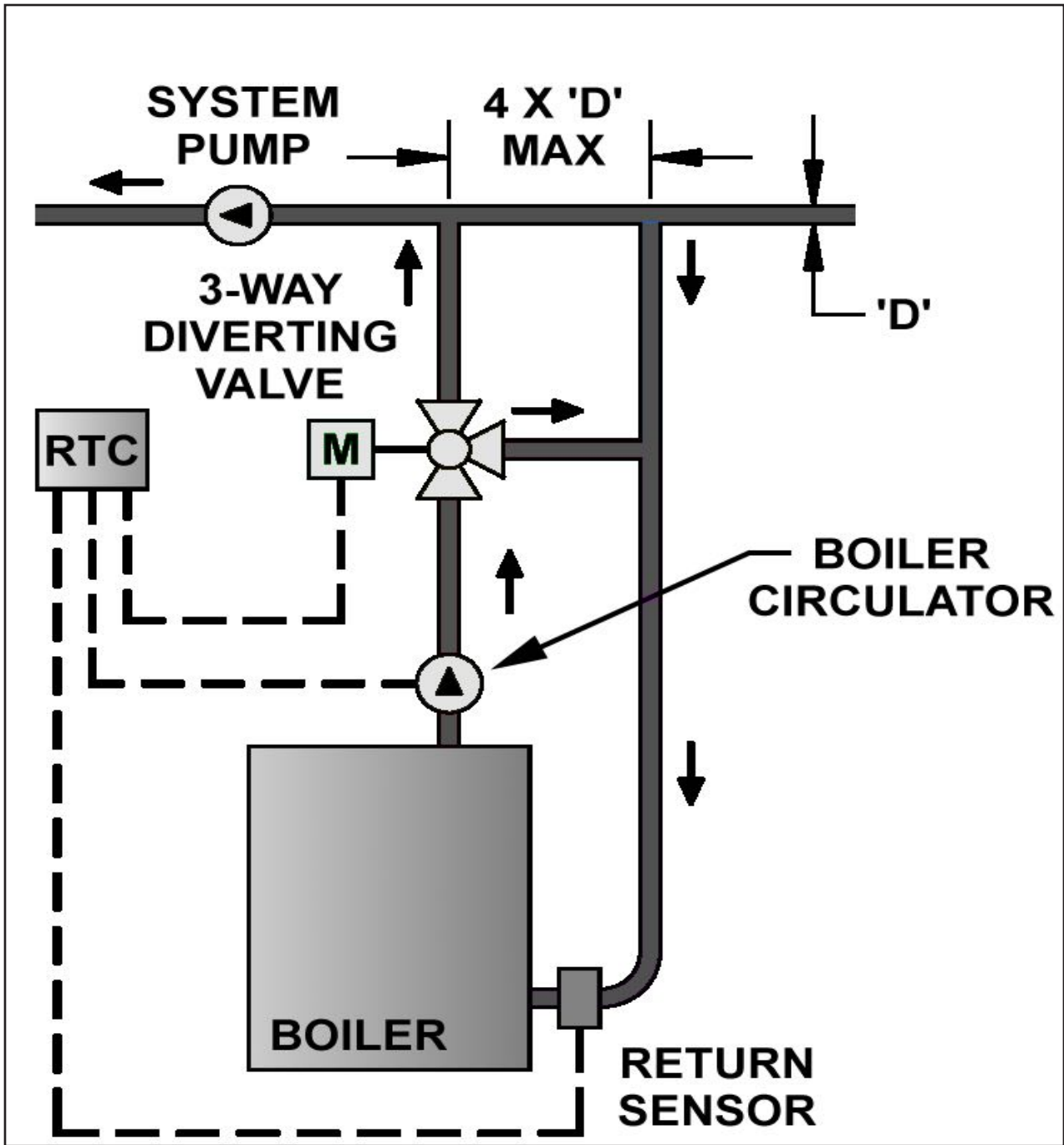

Figure 5: Typical Burnham Boiler Loop w/3-Way Diverting Valve

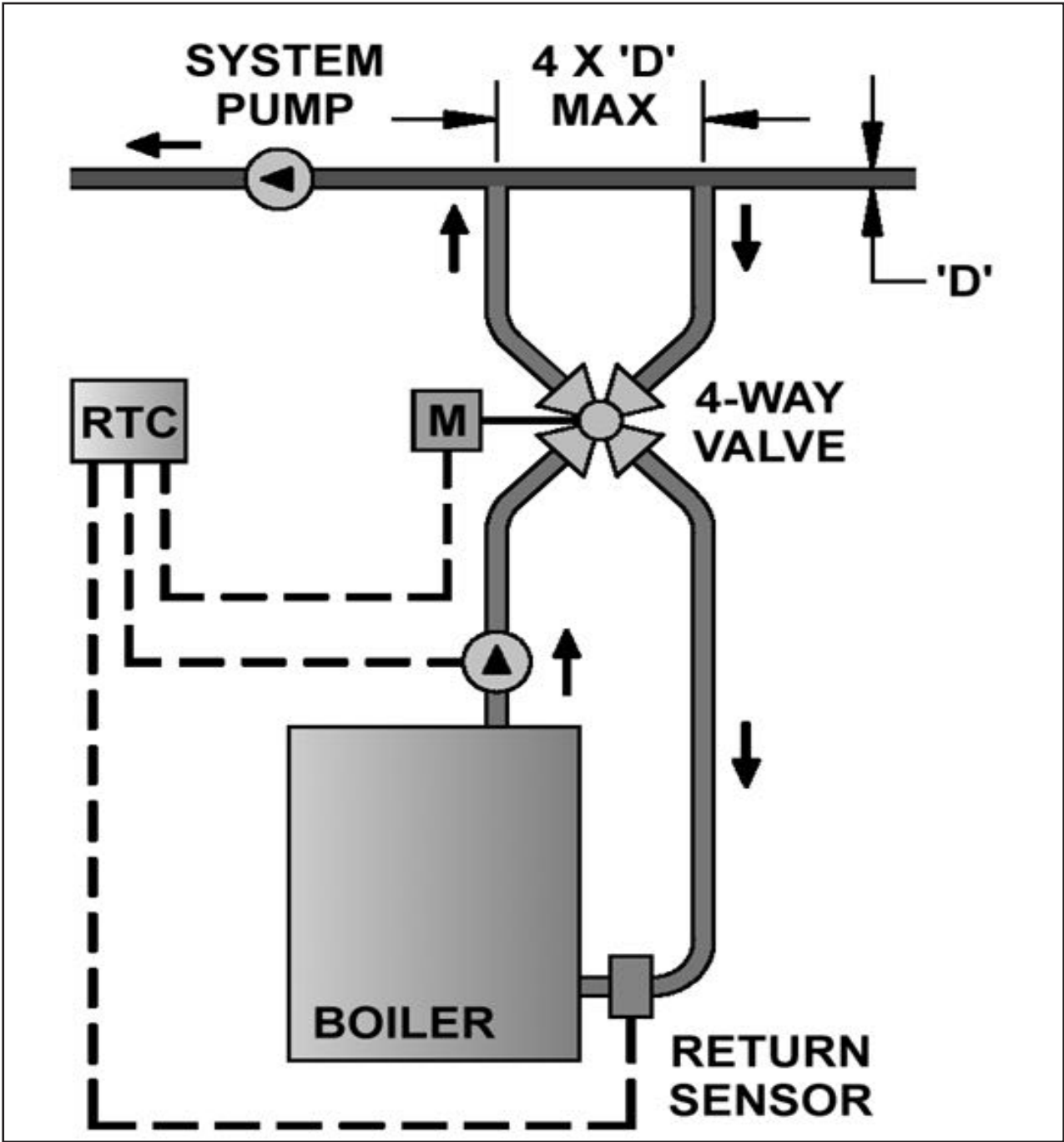

Figure 6: Typical Burnham Boiler Loop w/4-Way Diverting Valve

On multiple boiler applications, each boiler is installed in the same arrangement as a single boiler application. Each boiler loop contains its own boiler circulator, diverting valve and actuator, RTC control, and return sensor. A number of different boiler sequencers can be used in conjunction with the RTC by energizing the control's heat demand circuit. The RTC control's outdoor reset feature cannot be used on multiple boiler installations. The sequencer's outdoor reset feature (if available) would have to be utilized instead.

STEP FOUR ——— ROUGH-IN WIRING

All electrical wiring terminates in the control base wiring chamber. The base has standard $\frac{7}{8}$ " (22 mm) knockouts, which accept common wiring hardware and conduit fittings. Before removing the knockouts, check the wiring diagram and select those sections of the chamber with common voltages. Do not allow the wiring to cross between sections, as the wires will interfere with safety dividers, which should be installed at a later time.

Power must not be applied to any of the wires during the rough-in wiring stage.

- All wires are to be stripped to a length of 3/8 in (9 mm) to ensure proper connection to the control.
- If a Mix Sensor 071 or an Outdoor Sensor 070 is used, install the sensor according to the installation instructions in the Data Brochure D 070 and run the wiring back to the control.
- Make sure the Boiler Return Sensor is installed and run the wiring back to the control.
- Run wire from other system components (pumps, boilers, etc.) to the control.
- Run wires from the 120 V (ac) power to the control. Ideally, a separate dedicated circuit should power the control.
- Use a clean power source with a 15 A circuit to ensure proper operation. Multi-strand 16 AWG wire is recommended for all 120 V (ac) wiring due to its superior flexibility and ease of installation into the terminals.

STEP FIVE ——— ELECTRICAL CONNECTIONS TO THE CONTROL

The installer should test to confirm that no voltage is present at any of the wires. Push the control into the base and slide it down until it snaps firmly into place.

Powered Input Connections

120 V (ac) Power

Connect the 120 V (ac) power supply to the *Power L* and *Power N* terminals (3 and 4). This connection provides power to the microprocessor and display of the control. As well, this connection provides power to the *Boil Pmp* terminal (5). The control should be powered from a dedicated circuit. This avoids power disruption to the control in the event of failure on another electrical device on the same circuit. DO NOT power the control from the boiler or burner circuit, since there may be times where the boiler or burner circuit may be switched off in the summer. This would prevent the exercising of the boiler recirculating pump and the diverting valve. Boiler protection for dormant boilers, in a multiple boiler application, will not be possible if the control is not powered.

Heat Demand

To generate a heat demand, a voltage between 24 V (ac) and 240 V (ac) must be applied across the *Heat Demand* terminals (1 and 2).

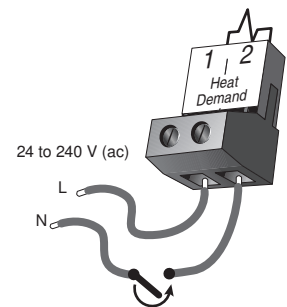
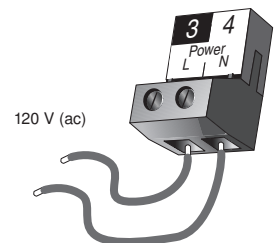

Output Connections

Boiler Recirculating Pump Contact (Boil Pmp)

The *Boil Pmp* output terminal (5) on the control is a powered output. When the relay in the control closes, 120 V (ac) is provided to the *Boil Pmp* terminal (5) from the *Power L* terminal (3). To operate the boiler recirculating pump, connect one side of the boiler recirculating pump circuit to terminal (5), and the second side of the pump circuit to the neutral (*N*) terminal (6).

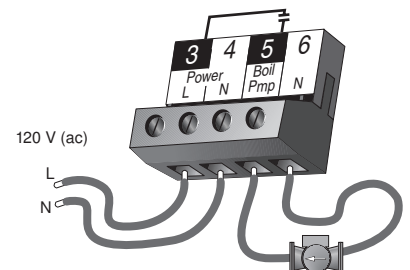

Diverting Valve Actuator

Terminals 9, 10 and 11 are powered with 24 V (ac) from the control. There is no need to provide a separate 24 V (ac) power source for the diverting valve actuator. *R* (9) is connected to the open terminal of the actuating motor and *R* (10) is connected to the close terminal of the actuating motor. *N* (11) is then connected to the common terminal of the actuating motor.

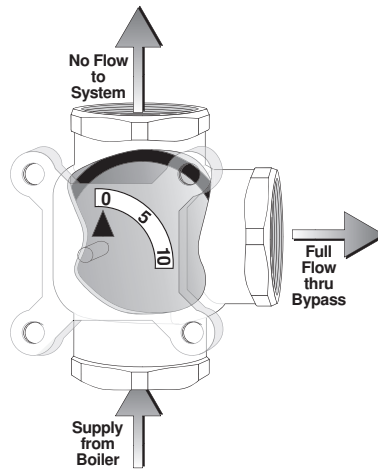
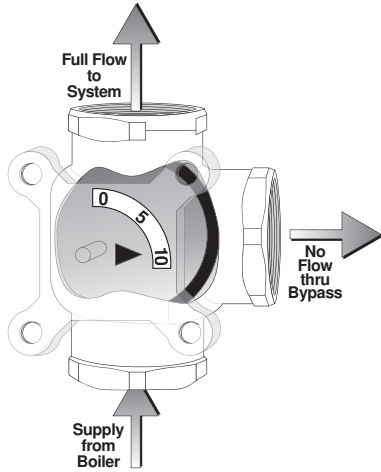
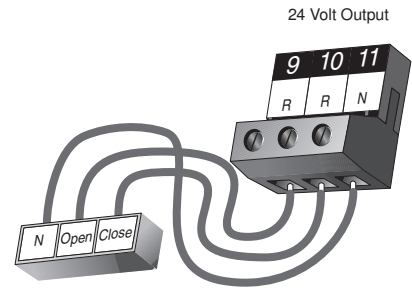

CLOCKWISE (CW) = OPEN TO SYSTEM
COUNTER CLOCKWISE (CCW) = CLOSED TO SYSTEM

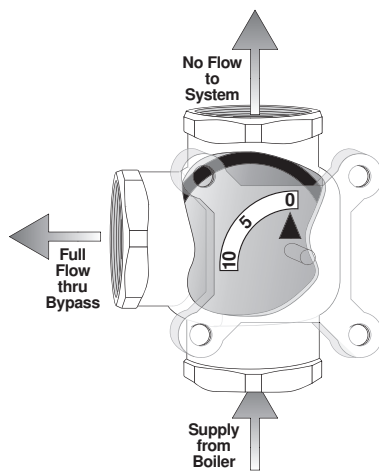
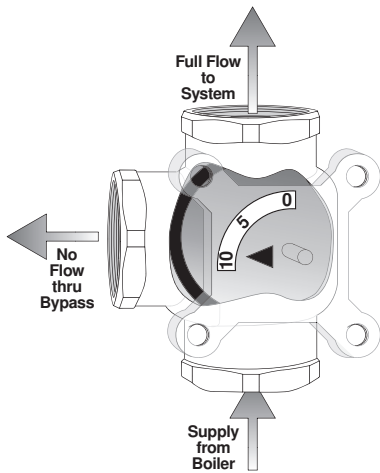
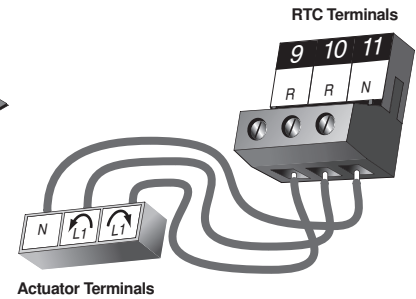

COUNTER CLOCKWISE (CCW) = OPEN TO SYSTEM
CLOCKWISE (CW) = CLOSED TO SYSTEM

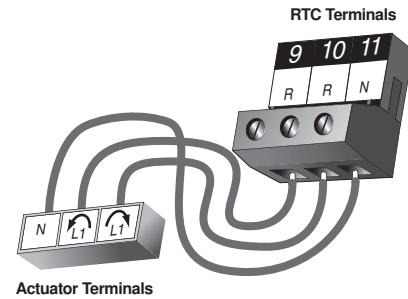

The control's Test Sequence can be used to check the motor circuit. Once the Test button is pressed, the valve should move to the fully open position. If the motor closes instead of opening, the wiring of the actuating motor must be reversed. Next, the valve should move to the fully closed position. If it does not, check the wiring between the terminals and the actuating motor. Refer to any installation or troubleshooting information supplied with the motor.

Boiler Enable Contact

The *Boiler Enable* terminals (7 and 8) are an isolated output in the control. There is no power available on these terminals from the control. These terminals are to be used as a switch to either make or break the boiler limit circuit. When the control requires the boiler to fire, it closes the contact between terminals 7 and 8.

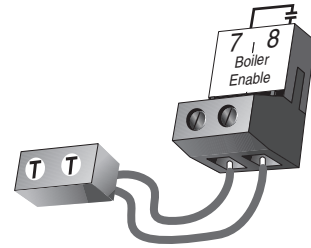

Sensor and Unpowered Input Connections

Do not apply power to these terminals, as this will damage the control.

Boiler Return Sensor

Connect the two wires from the Boiler Return Sensor to the *Com* and *Boil Ret* terminals (12 and 13). The boiler return sensor is used by the control to measure the boiler return temperature.

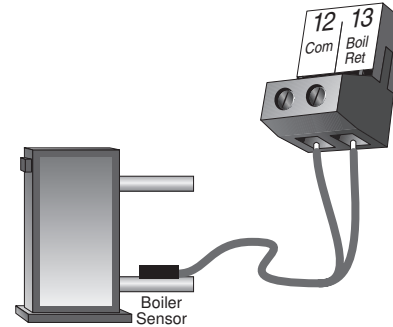

Mix Sensor (Outdoor Reset and Setpoint Modes)

Connect the two wires from the Mix Sensor 071 to the *Com* and *Mix* terminals (12 and 14). The mix sensor is used by the control to measure the mixed supply water temperature in the primary loop. Typically the sensor is attached to the pipe downstream of the system pump.

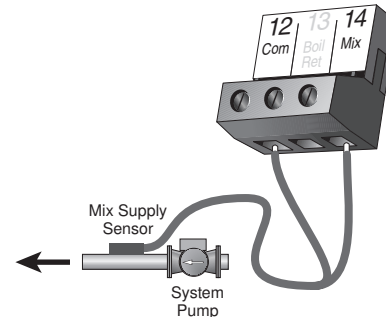

Outdoor Sensor (Outdoor Reset Mode)

Connect the two wires from the Outdoor Sensor 070 to the *Com* and *Out* terminals (15 and 16). The outdoor sensor is used by the control to measure the outdoor air temperature.

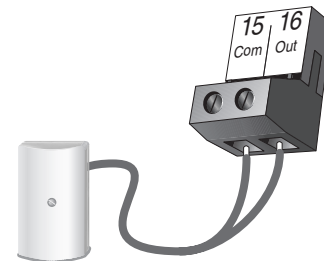

STEP SIX TESTING THE WIRING

Each terminal block **must be unplugged** from its header on the control before power is applied for testing. To remove the terminal block, pull straight down from the control.

The following tests are to be performed using standard testing practices and procedures and should only be carried out by properly trained and experienced persons.

A good quality electrical test meter, capable of reading from at least 0 – 300 V (ac) and at least 0 – 2,000,000 Ohms, is essential to properly test the wiring and sensors.

Test the Sensors

A good quality test meter capable of measuring up to 2,000,000 Ω ($1k\Omega = 1000 \Omega$) is required to measure the sensor resistance. In addition to this, the actual temperature should be measured with a good quality digital thermometer.

First measure the temperature using the thermometer. Then measure the resistance of the sensor at the control. The wires from the sensor must not be connected to the control while the test is performed. Using the chart below, estimate the temperature measured by the sensor. The sensor and thermometer readings should be close. If the test meter reads a very high resistance, there may be a broken wire, a poor wiring connection or a defective sensor. If the resistance is very low, the wiring may be shorted, there may be moisture in the sensor or the sensor may be defective. To test for a defective sensor, measure the resistance directly at the sensor location.

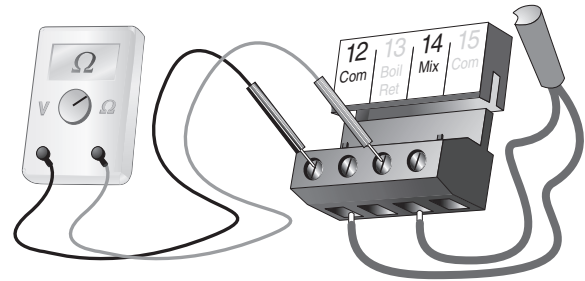

Do not apply voltage to a sensor at any time as damage to the sensor may result.

Temperature		Resistance	Temperature		Resistance	Temperature		Resistance	Temperature		Resistance
$^{\circ}\text{F}$	$^{\circ}\text{C}$	Ω	$^{\circ}\text{F}$	$^{\circ}\text{C}$	Ω	$^{\circ}\text{F}$	$^{\circ}\text{C}$	Ω	$^{\circ}\text{F}$	$^{\circ}\text{C}$	Ω
-50	-46	490,813	20	-7	46,218	90	32	7,334	160	71	1,689
-45	-43	405,710	25	-4	39,913	95	35	6,532	165	74	1,538
-40	-40	336,606	30	-1	34,558	100	38	5,828	170	77	1,403
-35	-37	280,279	35	2	29,996	105	41	5,210	175	79	1,281
-30	-34	234,196	40	4	26,099	110	43	4,665	180	82	1,172
-25	-32	196,358	45	7	22,763	115	46	4,184	185	85	1,073
-20	-29	165,180	50	10	19,900	120	49	3,760	190	88	983
-15	-26	139,402	55	13	17,436	125	52	3,383	195	91	903
-10	-23	118,018	60	16	15,311	130	54	3,050	200	93	829
-5	-21	100,221	65	18	13,474	135	57	2,754	205	96	763
0	-18	85,362	70	21	11,883	140	60	2,490	210	99	703
5	-15	72,918	75	24	10,501	145	63	2,255	215	102	648
10	-12	62,465	80	27	9,299	150	66	2,045	220	104	598
15	-9	53,658	85	29	8,250	155	68	1,857	225	107	553

Test the Power Supply

Make sure exposed wires and bare terminals are not in contact with other wires or grounded surfaces. Turn on the power and measure the voltage between the *Power L* and *Power N* terminals (3 and 4) using an AC voltmeter, the reading should be between 108 and 132 V (ac).

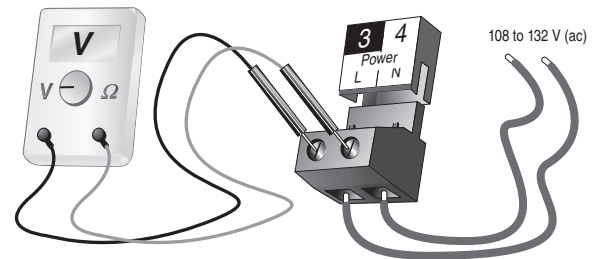

Test the Powered Inputs

Heat Demand

Measure the voltage between the *Heat Demand* terminals (1 and 2). When the heat demand device calls for heat, between 20 and 260 V (ac) should be measured at the terminals. When the heat demand device is off, less than 5 V (ac) should be measured.

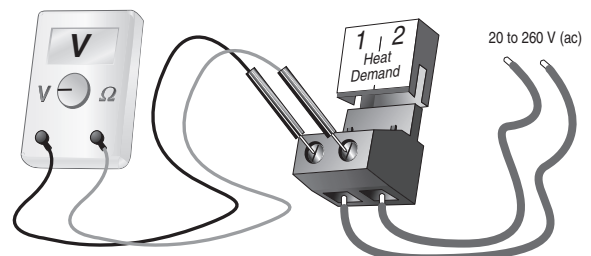

Test the Outputs

Boiler Recirculating Pump (Boil Pmp)

The boiler recirculating pump is connected to the *Boil Pmp* terminal (5). Make sure that power to the terminal block is off, and install a jumper between the *Power L* and the *Boil Pmp* terminals (3 and 5). Install a second jumper between *Power N* and *N* terminals (4 and 6). When power is applied to the *Power L* and *Power N* terminals (3 and 4), the boiler recirculating pump should start. If the pump does not turn on, check the wiring between the terminal block and pump, and refer to any installation or troubleshooting information supplied with the pump. If the pump operates properly, disconnect the power and remove the jumpers.

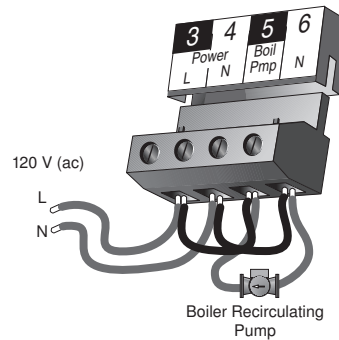

Boiler Enable Contact

If the boiler limit circuit is connected to the *Boiler Enable* terminals (7 and 8), make sure power to the boiler circuit is off, and install a jumper between the terminals. When the boiler limit circuit is powered up, the boiler should fire. If the boiler does not turn on, refer to the installation or troubleshooting information supplied with the boiler. Check for proper operation of each device in the boiler limit circuit. If the boiler operates properly, disconnect the power and remove the jumper.

Connecting the Control

Make sure all power to the devices and terminal blocks is off, and remove any remaining jumpers from the terminals.

Reconnect the terminal blocks to the control by carefully aligning them with their respective headers on the control, and then pushing the terminal blocks into the headers. The terminal blocks should snap firmly into place.

Install the supplied safety dividers between the unpowered sensor inputs and the powered or 120 V (ac) wiring chambers.

Apply power to the control. The operation of the control on power up is described in the Sequence of Operation section of this manual.

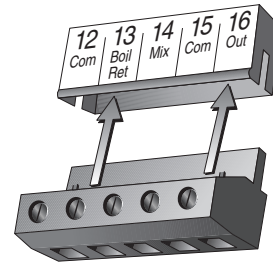

STEP SEVEN — ADJUSTING THE CONTROL SETPOINTS

In order for the RTC to function properly, several control settings must be adjusted. Review the “User Interface” and “Sequence of Operation” sections of this manual for descriptions of each setting and instructions on how to adjust them. Adjust the following settings as specified:

A. ROOM (Room Temperature) – Set the desired room temperature.

B. MIX TARGET – This setting can only be used on applications where the mix sensor is installed. When the outdoor reset feature is not selected, this setting represents the fixed target supply water temperature. On this type of application, the MIX TARGET setting should be adjusted to match the boiler operating aquastat’s setpoint temperature.

C. MIX DSGN (Mixing Design) – When the outdoor reset feature is selected, this setting represents the design system supply water temperature. If unsure about the original design temperature, set the MIX DSGN to match the boiler operating aquastat’s setpoint temperature.









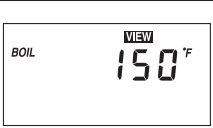
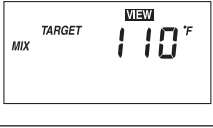
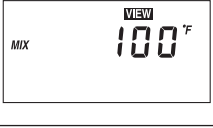
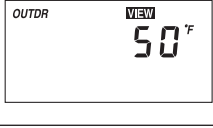
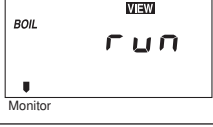
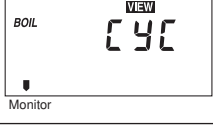
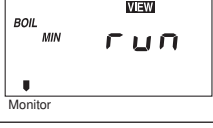
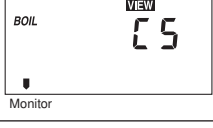
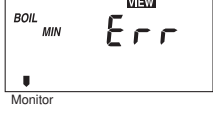

D. OUTDR DSGN (Outdoor Design) – When the outdoor reset feature is selected, this setting represents the typical coldest temperature of the year in the area where the installation is located. If this value is unknown, use the temperature value found in ASHRAE Fundamentals for the area closest to the installation.

- E. WWSD (Warm Weather Shut Down)** – This feature is only used when the outdoor reset feature is selected. Set the WWSD as desired, keeping in mind that, when the outdoor air temperature rises above the WWSD setting, the control will not operate the boiler to satisfy any demands for heat.
- F. MIX MIN (Mixing Minimum)** – When the outdoor reset feature is selected, this setting represents the minimum mix target supply water temperature. Set as desired.
- G. MIX MAX (Mixing Maximum)** – When the outdoor reset feature is selected, this setting represents the maximum allowable mix target supply water temperature. Typically, this is set between 200°F and 220°F. However, the MIX MAX setting must be below the highest permissible temperature for any system component affected by the boiler supply water.
- H. OPEN DELAY** – This setting represents the number of seconds required for the actuator to move the valve from a fully closed to a fully open position. Keep this setting at the default value of 50 seconds.
- I. BOIL MIN (Boiler Minimum)** – This setting represents the minimum allowable boiler return water temperature. Keep this setting at 135°F, unless a higher minimum return water temperature is required.
- J. BOIL MIN DELAY (Boiler Minimum Delay)** – This setting represents the number of seconds required for warm-up during an initial cold start. Use the appropriate value from Table I or II, depending on the specific application. (These values include 90 seconds of pre-purge time.)
- K. PUMP DELAY** – This setting represents the time (in seconds) for boiler circulator (pump) purge after a heat demand cycle. This minimizes the amount of boiler temperature overshoot at the end of a cycle. During the pump purge, the diverting valve will continue to operate and prevent low temperature return water from entering the boiler. At the end of the pump purge period, the diverting valve will close immediately. Set the pump delay as desired. (The default setting is 30 seconds.)

STEP EIGHT ————— CLEANING THE CONTROL —————

The control's exterior can be cleaned using a damp cloth. Moisten the cloth with water and wring out prior to wiping control. Do not use solvents or cleaning solutions.

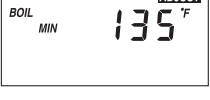
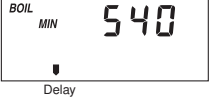
Display	Section	Description	Range
	D	BOIL Current boiler return temperature as measured by the boiler sensor.	14 to 266°F (-10 to 130°C)
	D	MIX TARGET Target mixed supply is the temperature the control is currently trying to maintain at the mixing sensor. (Mix sensor is present or OUTDR DSGN = OFF)	---, 14 to 266°F (---,-10 to 130°C)
	D	MIX Current mixed supply water temperature as measured by the mixing sensor. (Mix sensor is present or OUTDR DSGN = OFF)	14 to 266°F (-10 to 130°C)
	D	OUTDR Current outdoor air temperature as measured by the outdoor sensor. (Outdoor sensor is present and OUTDR DSGN ≠ OFF)	-67 to 149°F (-55 to 65°C)
	D	Monitor BOIL run The control records the number of hours the boiler enable contact has been closed.	run <> 0 to 99 999
	D	Monitor BOIL CYC The control records the number of boiler enable relay cycles.	CYC <> 0 to 99 999
	D	Monitor BOIL MIN run Below return water minimum. The control records the number of hours the boiler operates below the boiler minimum setting.	run <> 0 to 99 999
	D	Monitor BOIL CS The number of times the boiler has experienced cold shock conditions.	CS <> 0 to 99 999
	D	Monitor BOIL MIN Err The number of hours the boiler return sensor is not functioning.	Err <> 0 to 99 999

Display	Section	Description	Range	Actual Setting
	C	ROOM The desired room air temperature. (OUTDR DSGN ≠ OFF)	35 to 100°F (2 to 38°C) Default = 70°F (21°C)	
	C	MIX TARGET Mixing setpoint temperature. (OUTDR DSGN = OFF)	60 to 200°F (16 to 93°C) Default = 180°F (82°C)	
	C	MIX DSGN The design supply water temperature used in the heat loss calculation for the heating system. (OUTDR DSGN ≠ OFF)	70 to 210°F (21 to 99°C) Default = 180°F (82°C)	
	C	OUTDR DSGN The design outdoor air temperature used in the heat loss calculation for the heating system. For setpoint operation, set the OUTDR DSGN to OFF	-60 to 32°F, OFF (-51 to 0°C, OFF) Default = OFF	
	C	WWSD The system's warm weather shut down during the occupied (Day) period.	35 to 100°F, OFF (2 to 38°C, OFF) Default = 70°F (21°C)	
	C	MIX MIN The minimum supply temperature for the mixing system. (OUTDR DSGN ≠ OFF)	OFF, 35 to 150°F (OFF, 2 to 66°C) Default = OFF	
	C	MIX MAX The maximum supply water temperature for the mixing system. (OUTDR DSGN ≠ OFF)	80 to 220°F (27 to 104°C) Default = 200°F (93°C)	
	C	Open Delay The time the actuating motor requires to operate from fully closed to fully open.	30 to 230 seconds Default = 50 seconds	
	C	BOIL MIN The minimum boiler return water temperature.	135 to 230°F (57 to 110°C) Default = 135°F (57°C)	
	C	BOIL MIN Delay The amount of time the boiler requires to heat up to the boiler minimum temperature from a cold start.	210 to 540 seconds (10 second increments) Default = 540 seconds	
	C	Pump Delay The amount of time the boiler recirculating pump purges the boiler.	0 to 240 seconds Default = 30 seconds	
	C	Temperature Units The units of measure that all of the temperatures are to be displayed in the control.	°F, °C Default = °F	

Testing the Control

The control has a built-in test routine, which is used to test the main control functions. The control continually monitors the sensors, and displays an error message whenever a fault is found. See the following pages for a list of the control's error messages and possible causes. When the Test button is pressed, the test light is turned on. The individual outputs and relays are tested in the following test sequence.

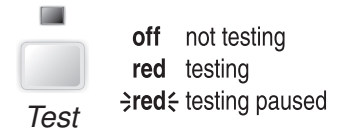

TEST SEQUENCE

Each step in the test sequence lasts at least 10 seconds.

During the test routine, the test sequence may be paused by pressing the Test button. Only if there is a heat demand can the control be paused in a step. If the Test button is not pressed again for 5 minutes while the test sequence is paused, the control exits the entire test routine. If the test sequence is paused, the Test button can be pressed again to advance to the next step. This can also be used to rapidly advance through the test sequence. To reach the desired step, repeatedly press and release the Test button until the appropriate device and segment in the display turn on.

Step 1 -The diverting valve is run fully open.

Step 2 -The diverting valve is run fully closed.

Step 3 -The boiler recirculating pump (Boil Pmp) is turned on and waits 10 seconds.

Step 4 -The Boiler Enable contact is turned on for 10 seconds. After 10 seconds, the Boiler Enable and Boil Pmp contacts are shut off.

Step 5 -The test sequence is completed and the control resumes its normal operation.

Troubleshooting

When troubleshooting any heating system, it is always a good idea to establish a set routine to follow. By following a consistent routine, many hours of potential headaches can be avoided. Below is an example of a sequence that can be used when diagnosing or troubleshooting problems in a hydronic heating system.

Establish the Problem

Establish the problem. Get as much information from the customer as possible about the problem. Is there too much heat, not enough heat, or no heat? Is the problem only in one particular zone or area of the building, or does the problem affect the entire system? Is this a consistent problem or only intermittent? How long has the problem existed for? This information is critical in correctly diagnosing the problem.

Understanding the Sequence of Operation

Understand the sequence of operation of the system. If a particular zone is not receiving enough heat, which pumps or valves in the system must operate in order to deliver heat to the affected zone? If the zone is receiving too much heat, which pumps, valves, or check valves must operate in order to stop the delivery of heat?

Use the Test Routine

Press the Test button on the control and follow the control through the test sequence as described in the Testing section. Pause the control as necessary to ensure that the correct device is operating as it should.

Sketch the Piping in the System

Sketch the piping of the system. This is a relatively simple step that tends to be overlooked, however, it can often save hours of time in troubleshooting a system. Note flow directions in the system paying close attention to the location of pumps, check valves, pressure bypass valves, and diverting valves. Ensure correct flow direction on all pumps. This is also a very useful step if additional assistance is required.

Document the Control

Document the control for future reference. Before making any adjustments to the control, write down all of the items that the control is currently displaying. This includes items such as error messages, current temperatures and settings, and which devices should be operating as indicated by the LCD. This information is an essential step if additional assistance is required to diagnose the problem.

Isolate the Problem

Isolate the problem between the control and the system. Now that the sequence of operation is known and the system is sketched, is the control operating the proper pumps and valves at the correct times? Is the control receiving the correct signals from the system as to when it should be operating? Are the proper items selected in the menus of the control for the device that is to be operated?

Test the Contacts, Voltages and Sensors

Test the contacts, voltages and sensors. Using a multimeter, ensure that the control is receiving adequate voltage to the power terminals and the demand terminals as noted in the technical data. Use the multimeter to determine if the internal contacts on the control are opening and closing correctly. Follow the instructions in the Testing the Wiring section to simulate closed contacts on the terminal blocks as required. Test the sensors and their wiring as described in the Test the Sensors section.

Error Messages



VIEW
E01

The control was unable to read a piece of information from its EEPROM. This error can be caused by a noisy power source. The control will load the factory defaults and continue operation if possible. All settings in the Adjust menu must be reviewed before the error will clear.



BOIL VIEW
Shr

The control is no longer able to read the boiler sensor due to a short circuit. The control will continue to enable the boiler and will operate the diverting valve at 30% output while there is a heat demand and until the sensor problem is repaired. The control will also record the time without the boiler return sensor. Locate and repair the problem as described in the Test the Sensors section. To clear the error message from the control after the sensor has been repaired, press the **Item** button.



BOIL VIEW
OPn

The control is no longer able to read the boiler sensor due to an open circuit. The control will continue to enable the boiler and will operate the diverting valve at 30% output while there is a heat demand and until the sensor problem is repaired. The control will also record the time without the boiler return sensor. Locate and repair the problem as described in the Test the Sensors section. To clear the error message from the control after the sensor has been repaired, press the **Item** button.



MIX VIEW
Shr

The control is no longer able to read the mix supply sensor due to a short circuit. In this case the control will operate the diverting valve at 30% output as long as there is a heat demand and until the sensor problem is repaired. Locate and repair the problem as described in the Test the Sensors section. To clear the error message from the control after the sensor has been repaired, press the **Item** button.



MIX VIEW
OPn

The control is no longer able to read the mix supply sensor due to an open circuit. In this case the control will operate the diverting valve at 30% output as long as there is a heat demand and until the sensor problem is repaired. Locate and repair the problem as described in the Test the Sensors section. To clear the error message from the control after the sensor has been repaired, press the **Item** button. **Note:** If a diverting valve is not installed, set the outdoor design (OUTDR DSGN) setting to OFF, power off the control and then re-power.



OUTDR VIEW
Shr

The control is no longer able to read the outdoor sensor due to a short circuit. In this case the control targets the design mix supply temperature and continues operation. Locate and repair the problem as described in the Test the Sensors section. To clear the error message from the control after the sensor has been repaired, press the **Item** button.



OUTDR VIEW
OPn

The control is no longer able to read the outdoor sensor due to an open circuit. In this case the control targets the design mix supply temperature and continues operation. Locate and repair the problem as described in the Test the Sensors section. To clear the error message from the control after the sensor has been repaired, press the **Item** button. **Note:** If a diverting valve is operated as a setpoint control, set the outdoor design (OUTDR DSGN) setting to OFF.

Repair Parts

RTC PARTS	Qty/Boiler	Part Number
Return Temperature Control (RTC) with boiler sensor and mounting screws	1	80160916
Control Motor, ESBE 92M, 24V, 50 Second motor, Danfoss #065F8953.	1	80160355
3-Way Diverting Valve, Danfoss #065B8968 - 1" NPT; Model MG25-12	1	80149013
3-Way Diverting Valve, Danfoss #065B8969 - 1-1/4" NPT; Model MG32-8	1	80160356
3-Way Diverting Valve, Danfoss #065B8953 - 1-1/2" NPT; Model G138	1	80160357
3-Way Diverting Valve, Danfoss #065B8954 - 2" NPT; Model G151	1	80160358
3-Way Diverting Valve, Danfoss #065B8960 - 2-1/2" flanged; Model F165-50	1	80160359
3-Way Diverting Valve, Danfoss #065B8961 - 2-1/2" flanged; Model F165	1	80160360
3-Way Diverting Valve, Danfoss #065B8962 - 3" flanged; Model F180	1	80160361
3-Way Diverting Valve, Danfoss #065B8963 - 4" flanged; Model F1100	1	80160362
3-Way Diverting Valve, Danfoss #065B8964 - 5" flanged; Model F1125	1	80160363
4-Way Diverting Valve, Danfoss #065B8985 - 1" NPT; Model 4 MG25-12	1	80149016
4-Way Diverting Valve, Danfoss #065B8986 - 1-1/4" NPT; Model MG32-8	1	80149017
4-Way Diverting Valve, Danfoss #065B8979 - 1-1/2" NPT; Model G438	1	80149024
4-Way Diverting Valve, Danfoss #065B8980 - 2" NPT; Model G451	1	80149025
4-Way Diverting Valve, Danfoss #065B6150 - 2-1/2" flanged; Model F450	1	80160366
4-Way Diverting Valve, Danfoss #065B6165 - 2-1/2" flanged; Model F465	1	80149026
4-Way Diverting Valve, Danfoss #065B6180 - 3" flanged; Model F480	1	80160348
4-Way Diverting Valve, Danfoss #065B6200 - 4" flanged; Model F4100	1	80160364
4-Way Diverting Valve, Danfoss #065B6225 - 5" flanged; Model F4125	1	80160365
Boiler Sensor, 1/4"NPT, Brass with 32" Lead; to be mounted in special nipple	1	80160915
Nipple, 3" X 12", Special, 1/4" NPT 3" From End, SCH40	1	806600426
Mounting Bracket for Return Temperature Control (RTC), V9 & V11 Series	1	7016034
RTC System Retrofit Kit, Less Outdoor Reset and Mix Sensors, V9 & V11 Boiler	1	6016085
RTC System Retrofit Kit, With Outdoor Reset and Mix Sensors, V9 & V11 Boiler	1	6016086
Mix Sensor, tekmar #071 Universal Fluid Temperature Sensor, 10" lead for surface pipe mounting	1	80160173
Outdoor Air Sensor, tekmar #070	1	80160172
Relay, 24 Volt Coil, tekmar #003P	1	80160196
Relay, 120 Volt Coil, tekmar #004P	1	80160165
3-Way Flange Kit; 2Q" flange x 2Q" NPT	1	60160870
3-Way Flange Kit; 3" flange x 3" NPT	1	60160871
3-Way Flange Kit; 4" flange x 4" NPT	1	60160872
3-Way Flange Kit; 5" flange x 5" NPT	1	60160873
3-Way Flange Kit; 4" flange x 4" slip on weld flange	1	60160874
3-Way Flange Kit; 5" flange x 5" slip on weld flange	1	60160875

This page has intentionally been left blank.

Appendix A: Application Drawings

A1. 3-way RTC in Primary/Secondary - Heating Only/No DHW; with/without Outdoor Reset (Mechanical)

C1 = Diverting Valve Actuator
M1 = By-Pass Mix Point
P1 = Boiler Circulator
P2 = System Pump (runs on call for heat)
S1 = Boiler Return Sensor
S2 = Mix Supply Sensor 071 (Required for Reset or Set-point Control)
S3 = Outdoor Sensor 070 (Required for Reset Control)
V1 = 3-Way Diverting Valve
V2 = Ball Valve, Balancing Valve
Z1...Z3 = Zones

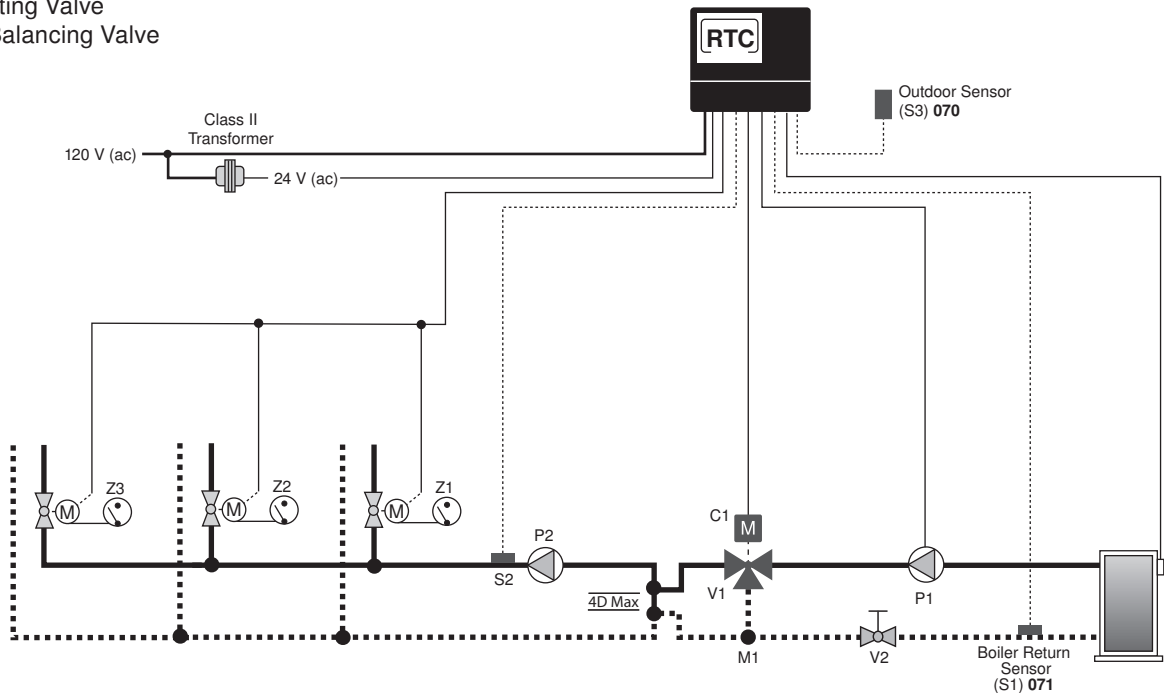

NOTES:

- 1) Install the boiler as indicated above for systems where return temperatures may be less than 135F and heating application only.
- 2) The Outdoor Sensor (S3) and the Mix Supply Sensor (S2) are required when the Outdoor Reset feature is selected. The mix sensor must be installed 10 pipe diameters downstream of the system pump, in the primary loop. The mix sensor must be secured to the surface of the pipe using a wire tie or similar device.
- 3) The by-pass piping, diverting valve and boiler circulator must be sized using the sizing charts found in Appendix B.
- 4) Closely spaced tees must connect the branch to the larger header. The Tee centerlines must be no greater than 4 times the larger header pipe diameter.
- 5) The diverting valve, V1, must be no greater than 11 linear feet of pipe from the Return Sensor, S1.
- 6) There shall be a MINIMUM of 4 linear feet of pipe between the By-pass Mix Point, M1, and the Return Sensor, S1.
- 7) The balancing valve in the boiler return line, V2, may be necessary in low head by-pass loop applications.
- 8) Expansion tanks, air scoops and other components left out for clarity.
- 9) Observe all applicable plumbing and electrical codes.

This diagram is for reference only. The installer or designer is responsible for the proper selection and design of the system.

A1. 3-way RTC in Primary/Secondary - Heating Only/No DHW; with/without Outdoor Reset (Electrical)

- C1 = Mixing Valve Actuating Motor
- P1 = Boiler Circulator
- S1 = Boiler Return Sensor
- S2 = Mix Supply Sensor 071
- S3 = Outdoor Sensor 070
- Z1...Z3 = Zone Valves, Zone Relays,
Thermostats or BMS Signal

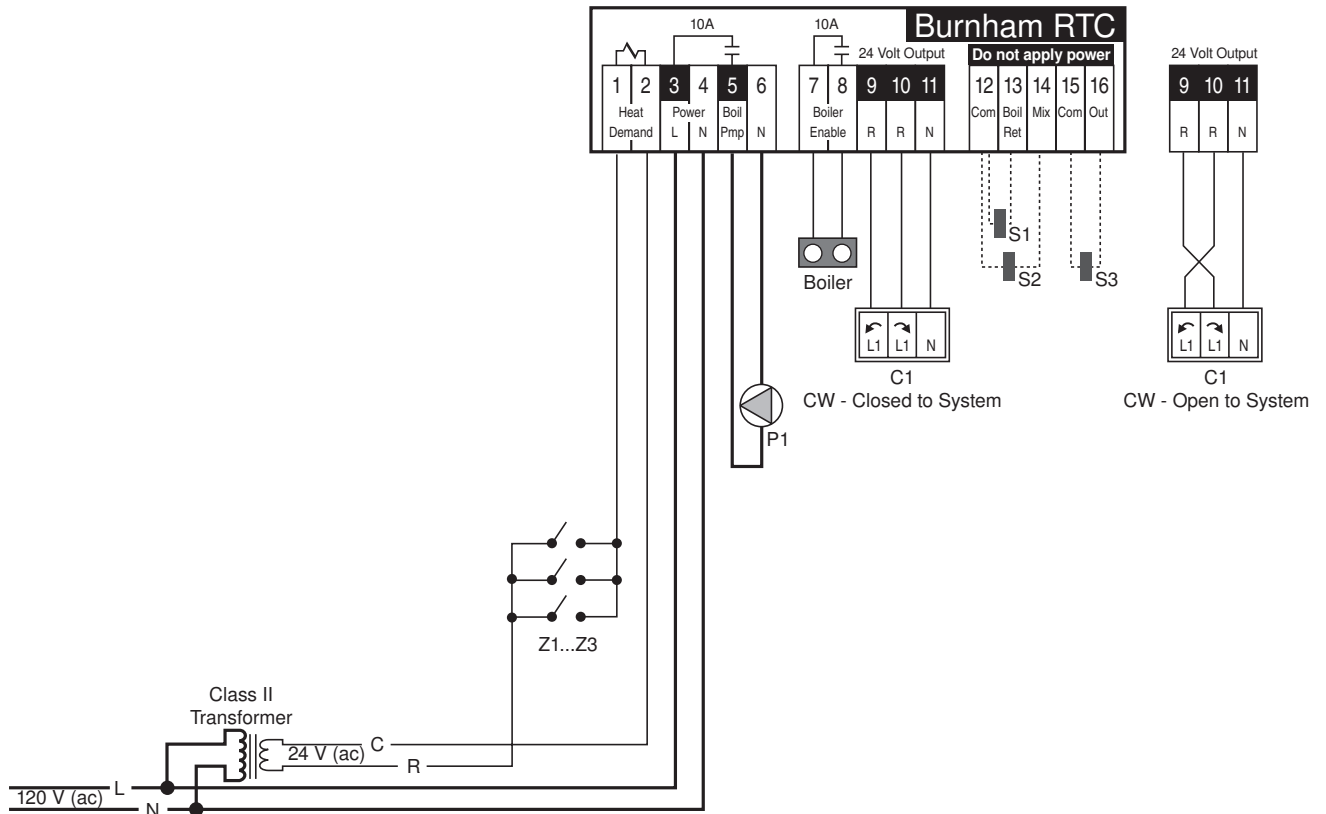

NOTES:

- 1) Refer to the I&O to determine correct valve orientation and actuator wiring.
- 2) 120 VAC supplying the RTC should be separate from the burner/boiler circuit.
- 3) Heat demand can be any electrical signal consisting of 24 - 240 VAC.
- 4) Use isolation relays for circulators greater than 1/3 HP. Use motor starters for 3 phase circulators.
- 5) The Outdoor Sensor (S3) and the Mix Supply Sensor (S2) are required if the Outdoor Reset feature is selected.
- 6) System Pump (P2) to be operated by zone relay or other installer supplied device.

This diagram is for reference only. The installer or designer is responsible for the proper selection and design of the system.

A2. 3-way RTC in Primary/Secondary - Heating and DHW using Tankless Coil; with/without Outdoor Reset (Mechanical)

A1 = Tankless Coil or Storage Tank Aquastat
 C1 = Mixing Valve Actuating Motor
 M1 = By-Pass Mix Point
 P1 = Boiler Circulator
 P2 = Tankless System Circulator
 P3 = System Pump (runs on call for heat)
 R1 = Relay (Required with and without priority)
 R2 = Relay (Required for Priority)
 S1 = Boiler Return Sensor
 S2 = System Mix Sensor 071
 S3 = Outdoor Sensor 070
 ST1= Storage Tank
 TK1= Tankless Coil
 V1 = 3-Way Diverting Valve
 V2 = Ball Valve, Balancing Valve
 Z1...Z3 = Zones

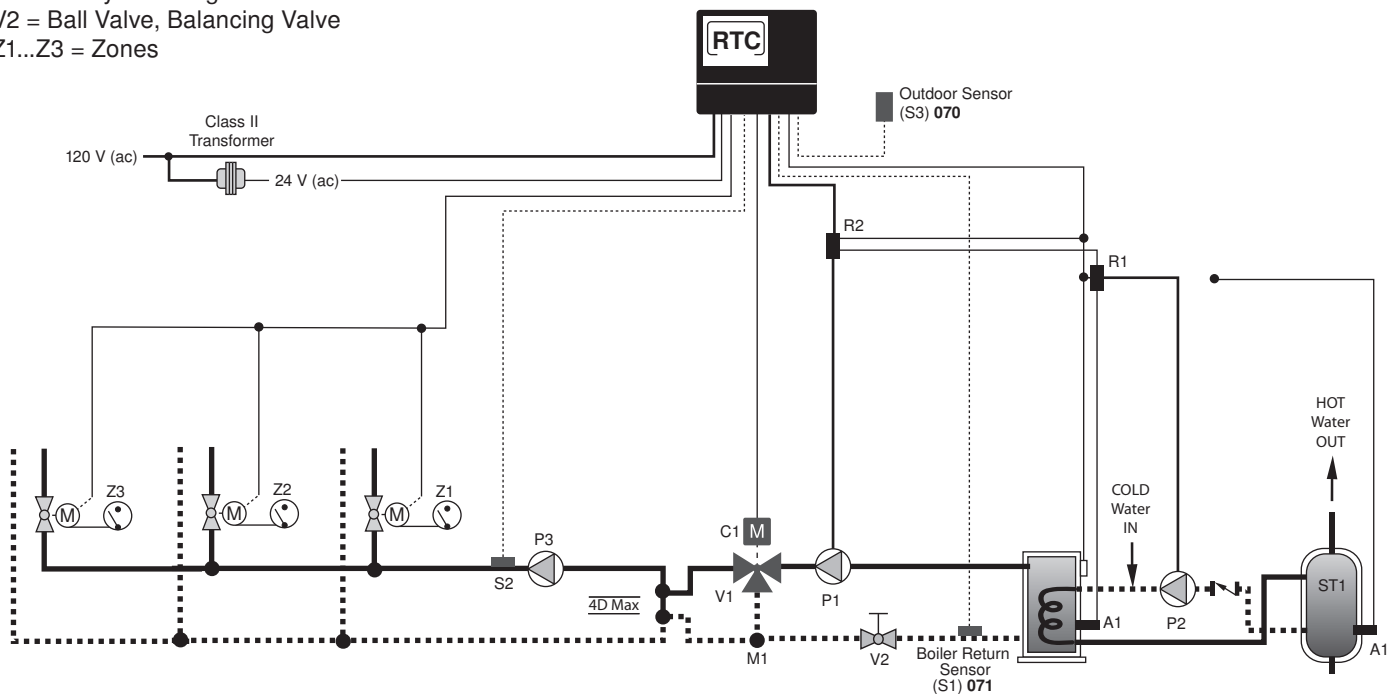

NOTES:

- 1) Install the boiler as indicated above for systems where return temperatures may be less than 135F and heating/DHW with tankless coils..
- 2) The Outdoor Sensor (S3) and the Mix Supply Sensor (S2) are required when the Outdoor Reset feature is selected. The mix sensor must be installed 10 pipe diameters downstream of the system pump, in the primary loop. The mix sensor must be secured to the surface of the pipe using a wire tie or similar device.
- 3) The by-pass piping, diverting valve and boiler circulator must be sized using the sizing charts found in Appendix B.
- 4) Closely spaced tees must connect the branch to the larger header. The Tee centerlines must be no greater than 4 times the larger header pipe diameter.
- 5) The diverting valve, V1, must be no greater than 11 linear feet of pipe from the Return Sensor, S1.
- 6) There shall be a MINIMUM of 4 linear feet of pipe between the By-pass Mix Point, M1, and the Return Sensor, S1.
- 7) The balancing valve in the boiler return line, V2, may be necessary in low head by-pass loop applications.
- 8) Domestic Hot Water must be tempered for safe usage. The tankless aquastat and/or storage tank aquastat (A1) are normally closed switches. Circuit breaks on temperature rise.
- 9) Expansion tanks, air scoops and other components left out for clarity.
- 10) Observe all applicable plumbing and electrical codes.

This diagram is for reference only. The installer or designer is responsible for the proper selection and design of the system.

A2. 3-way RTC in Primary/Secondary - Heating and DHW using Tankless Coil; with/without Outdoor Reset (Electrical)

- A1 = Tankless Coil or Storage Tank Aquastat
- C1 = Mixing Valve Actuating Motor
- P1 = Boiler Circulator
- P2 = Tankless Coil System Circulator
- R1 = Relay (Required with and without priority)
- R2 = Relay (Required for priority)
- S1 = Boiler Return Sensor
- S2 = Mix Supply Sensor 071
- S3 = Outdoor Sensor 070
- Z1...Z3 = Zone Valves, Zone Relays, Thermostats or BMS Signal

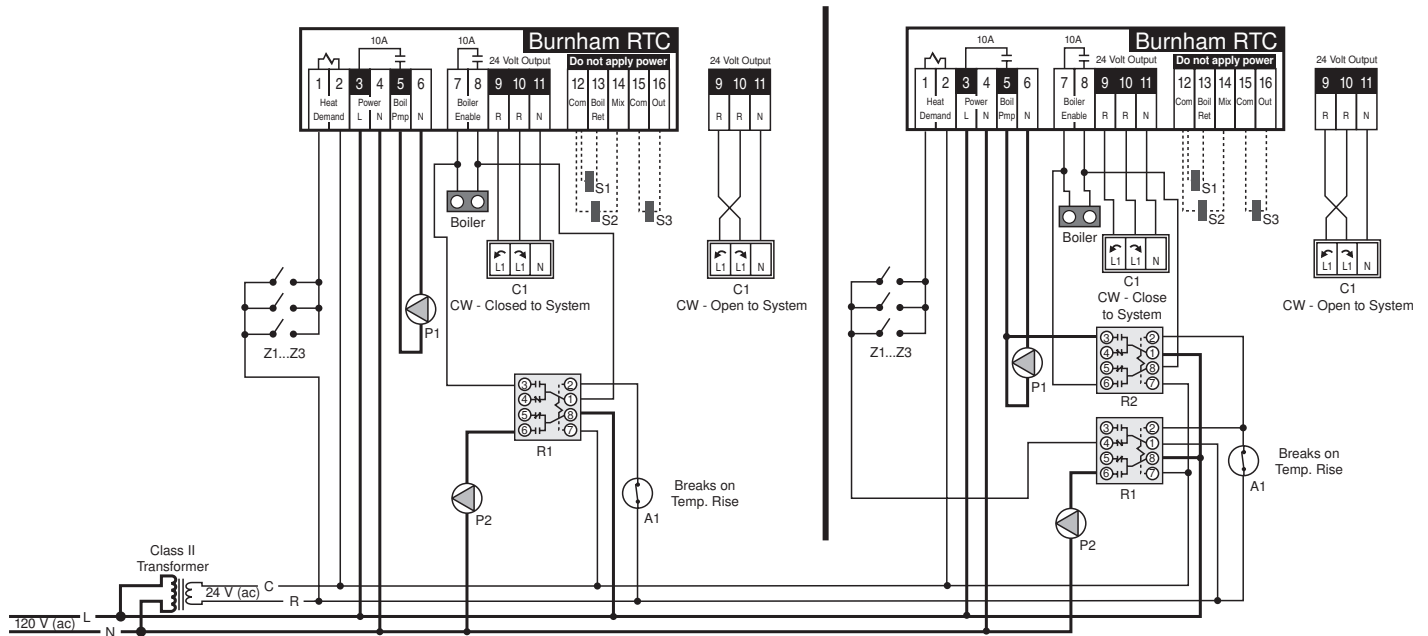

NOTES:

- 1) Refer to the I&O to determine correct valve orientation and actuator wiring.
- 2) 120 VAC supplying the RTC should be separate from the burner/boiler circuit.
- 3) Heat demand can be any electrical signal consisting of 24 - 240 VAC.
- 4) Use isolation relays for circulators greater than 1/3 HP. Use motor starters for 3 phase circulators.
- 5) The Outdoor Sensor (S3) and the Mix Supply Sensor (S2) are required if the Outdoor Reset feature is selected.
- 6) Connect the tankless aquastat (A1) if you are not using a storage tank. If you are using a storage tank with the tankless heater, use the storage tank aquastat.
- 7) System Pump (P3) to be operated by zone relay or other installer supplied device.

This diagram is for reference only. The installer or designer is responsible for the proper selection and design of the system.

A3. 3-way RTC in Primary/Secondary - Heating and DHW using Indirect Water Heater; with/without Outdoor Reset (Mechanical)

- A1 = Indirect Hot Water Aquastat
- C1 = Diverting Valve Actuating Motor
- M1 = By-Pass Mix Point
- P1 = Boiler Circulator
- P2 = Indirect Circulator
- P3 = System Pump (runs on call for heat)
- S1 = Boiler Return Sensor
- S2 = Mix Supply Sensor 071 (Required for Reset or Set-point Control)
- S3 = Outdoor Sensor 070 (Required for Reset Control)
- V1 = 3-Way Diverting Valve
- V2 = Ball Valve, Balancing Valve
- Z1...Z3 = Zones

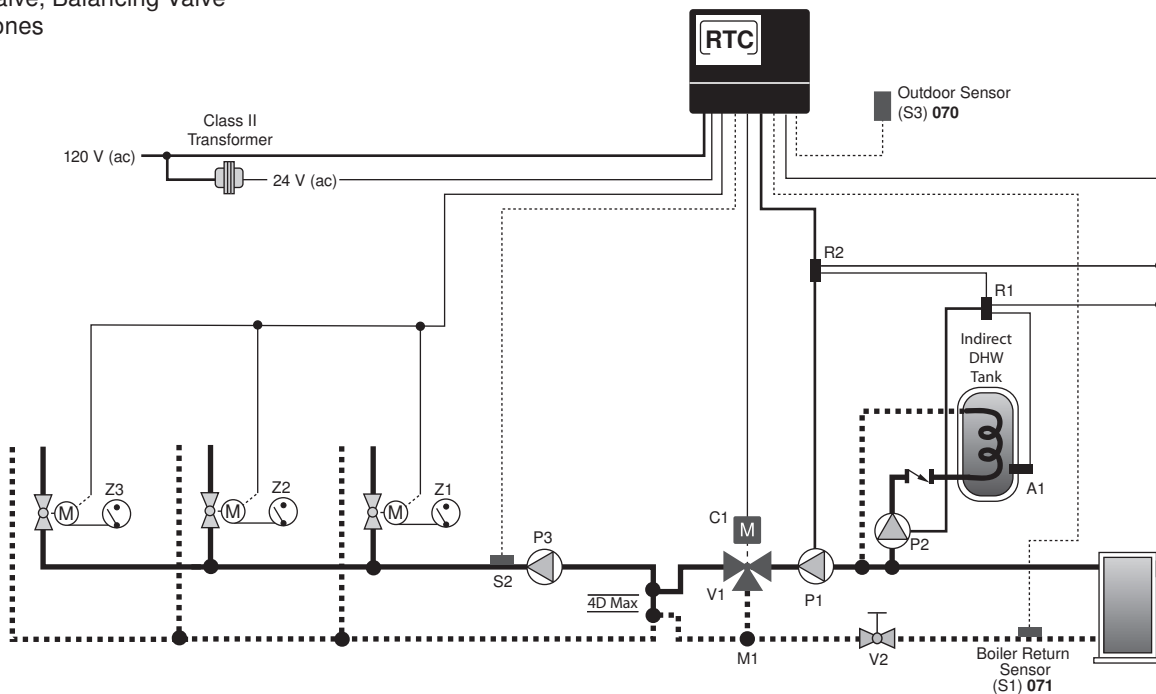

NOTES:

- 1) Install the boiler as indicated above for systems where return temperatures may be less than 135F and heating/DHW with an indirect water heater.
- 2) The Outdoor Sensor (S3) and the Mix Supply Sensor (S2) are required when the Outdoor Reset feature is selected. The mix sensor must be installed 10 pipe diameters downstream of the system pump, in the primary loop. The mix sensor must be secured to the surface of the pipe using a wire tie or similar device.
- 3) The by-pass piping, diverting valve and boiler circulator must be sized using the sizing charts found in Appendix B.
- 4) Closely spaced tees must connect the branch to the larger header. The Tee centerlines must be no greater than 4 times the larger header pipe diameter.
- 5) The diverting valve, V1, must be no greater than 11 linear feet of pipe from the Return Sensor, S1.
- 6) There shall be a MINIMUM of 4 linear feet of pipe between the By-pass Mix Point, M1, and the Return Sensor, S1.
- 7) The balancing valve in the boiler return line, V2, may be necessary in low head by-pass loop applications.
- 8) The indirect heater aquastat (A1) is a normally closed switch. Circuit breaks on temperature rise.
- 9) Expansion tanks, air scoops and other components left out for clarity.
- 10) Observe all applicable plumbing and electrical codes.

This diagram is for reference only. The installer or designer is responsible for the proper selection and design of the system.

A3. 3-way RTC in Primary/Secondary - Heating and DHW using Indirect Water Heater; with/without Outdoor Reset (Mechanical)

- A1 = Indirect Hot Water Aquastat
- C1 = Mixing Valve Actuating Motor
- P1 = Boiler Circulator
- P2 = Indirect Circulator
- R1 = Relay (Required with and without priority)
- R2 = Relay (Required for priority)
- S1 = Boiler Return Sensor
- S2 = Mix Supply Sensor 071
- S3 = Outdoor Sensor 070
- Z1...Z3 = Zone Valves, Zone Relays, Thermostats or BMS Signal

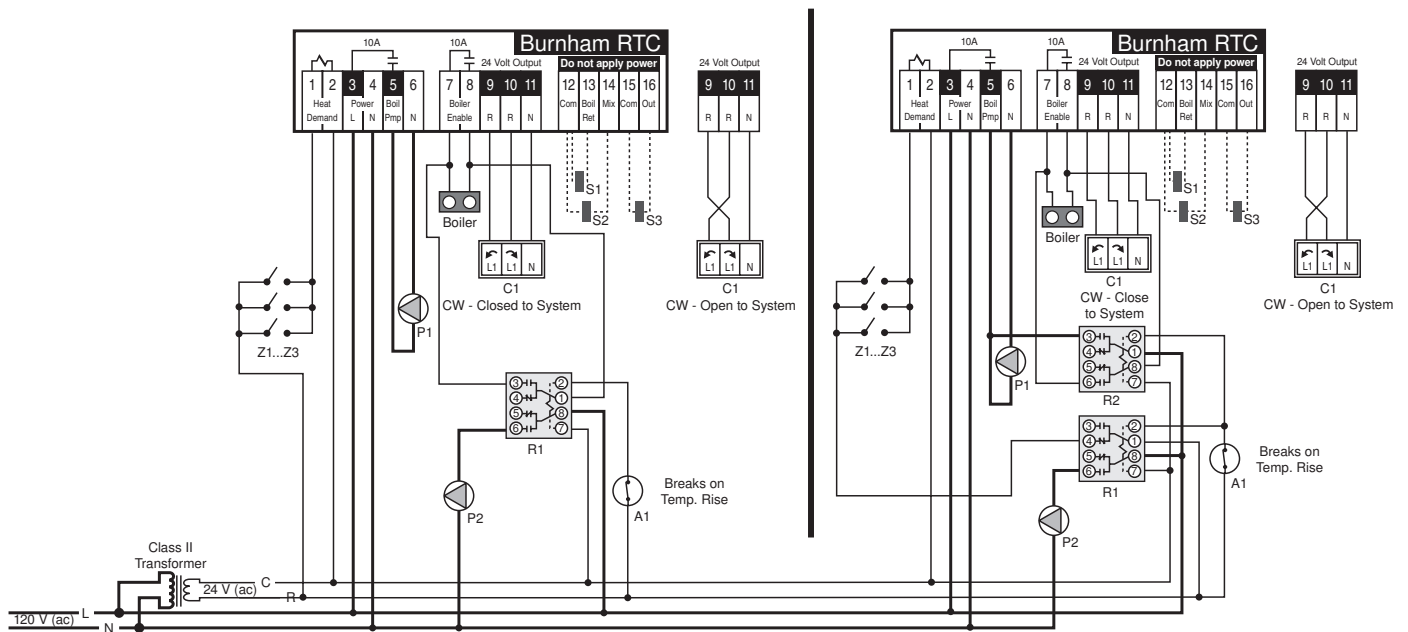

NOTES:

- 1) Refer to the I&O to determine correct valve orientation and actuator wiring.
- 2) 120 VAC supplying the RTC should be separate from the burner/boiler circuit.
- 3) Heat demand can be any electrical signal consisting of 24 - 240 VAC.
- 4) Use isolation relays for circulators greater than 1/3 HP. Use motor starters for 3 phase circulators.
- 5) The Outdoor Sensor (S3) and the Mix Supply Sensor (S2) are required if the Outdoor Reset feature is selected.
- 6) System Pump (P3) to be operated by zone relay or other installer supplied device.

This diagram is for reference only. The installer or designer is responsible for the proper selection and design of the system.

A4. 3-way RTC in Primary/Secondary - Heating and DHW using Indirect Water Heater on Primary Loop; without Outdoor Reset (Mechanical)

- A1 = Indirect Hot Water Aquastat
- C1 = Diverting Valve Actuating Motor
- M1 = By-Pass Mix Point
- P1 = Boiler Circulator
- P2 = Indirect Circulator
- P3 = System Pump (runs on call for heat)
- R1 = Relay
- S1 = Boiler Return Sensor
- V1 = 3-Way Diverting Valve
- V2 = Ball Valve, Balancing Valve
- V3 = Ball Valve, System Balancing
- Z1...Z3 = Zones

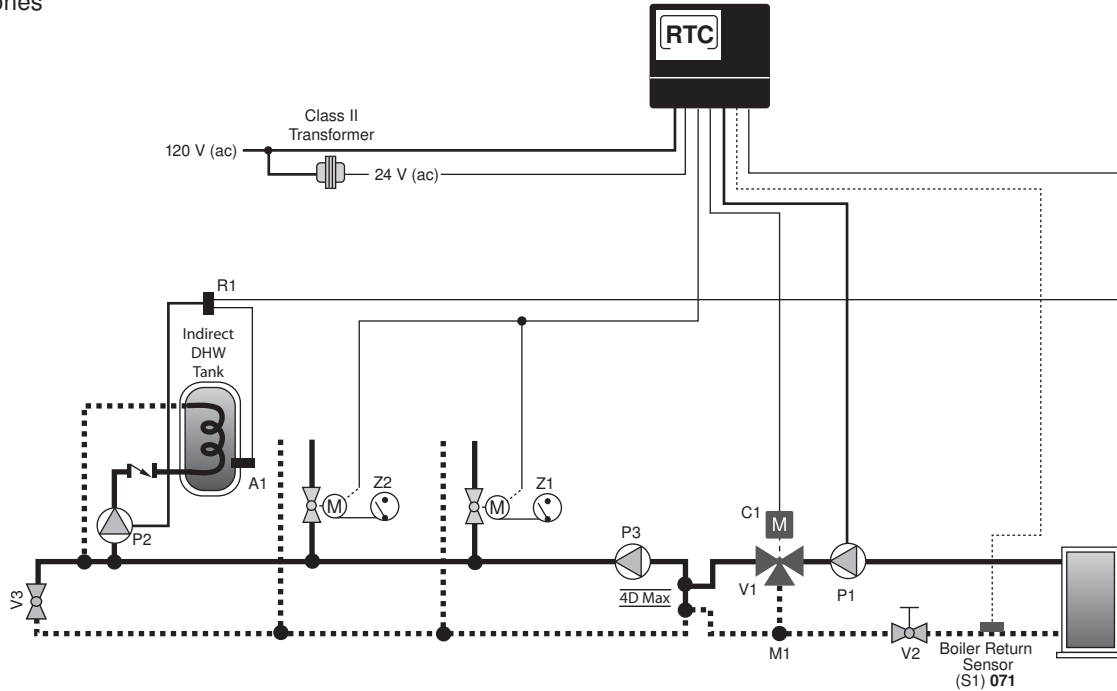

NOTES:

- 1) Install the boiler as indicated above for systems where return temperatures may be less than 135F and heating/DHW with an indirect water heater.
- 2) This arrangement is NOT recommended for outdoor reset applications. The reset temperature will constantly change DHW water performance.
- 3) The by-pass piping, diverting valve and boiler circulator must be sized using the sizing charts found in Appendix B.
- 4) A domestic hot water priority could be used provided the diversion from the heating system loop does not impact the system heater's performance.
- 5) Closely spaced tees must connect the branch to the larger header. The Tee centerlines must be no greater than 4 times the larger header pipe diameter.
- 6) The diverting valve, V1, must be no greater than 11 linear feet of pipe from the Return Sensor, S1.
- 7) There shall be a MINIMUM of 4 linear feet of pipe between the By-pass Mix Point, M1, and the Return Sensor, S1.
- 8) The balancing valve in the boiler return line, V2, may be necessary in low head by-pass loop applications.
- 9) The indirect heater aquastat (A1) is a normally closed switch. Circuit breaks on temperature rise.
- 10) Expansion tanks, air scoops and other components left out for clarity.
- 11) Observe all applicable plumbing and electrical codes.

This diagram is for reference only. The installer or designer is responsible for the proper selection and design of the system.

A4. 3-way RTC in Primary/Secondary - Heating and DHW using Indirect Water Heater on Primary Loop; without Outdoor Reset (Electrical)

- A1 = Indirect Hot Water Aquastat
- C1 = Mixing Valve Actuating Motor
- P1 = Boiler Circulator
- P2 = Indirect Circulator
- R1 = Relay
- S1 = Boiler Return Sensor
- Z1...Z3 = Zone Valves, Zone Relays, Thermostats or BMS Signal

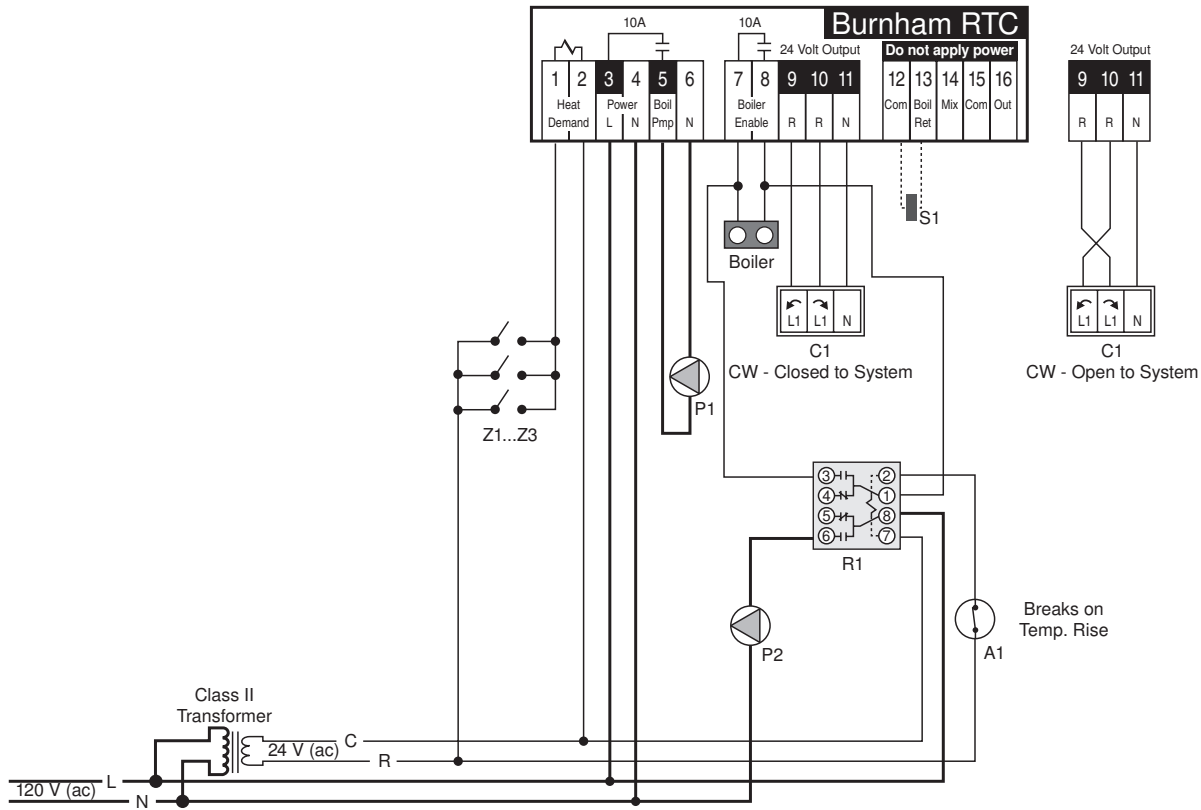

NOTES:

- 1) Refer to the I&O to determine correct valve orientation and actuator wiring.
- 2) 120 VAC supplying the RTC should be separate from the burner/boiler circuit.
- 3) Heat demand can be any electrical signal consisting of 24 - 240 VAC.
- 4) Use isolation relays for circulators greater than 1/3 HP. Use motor starters for 3 phase circulators.
- 5) System Pump (P3) to be operated by zone relay or other installer supplied device.

This diagram is for reference only. The installer or designer is responsible for the proper selection and design of the system.

A5. 4-way RTC in Primary/Secondary - Heating Only/No DHW; with/without Outdoor Reset (Mechanical)

- C1 = Diverting Valve Actuating Motor
- M1 = By-Pass Mix Point
- P1 = Boiler Circulator
- P2 = System Pump (runs on call for heat)
- S1 = Boiler Return Sensor
- S2 = Mix Supply Sensor 071 (Required for Reset Control)
- S3 = Outdoor Sensor 070 (Required for Reset Control)
- V1 = 4-Way Diverting Valve
- V2 = Ball Valve, Balancing Valve
- Z1...Z3 = Zones

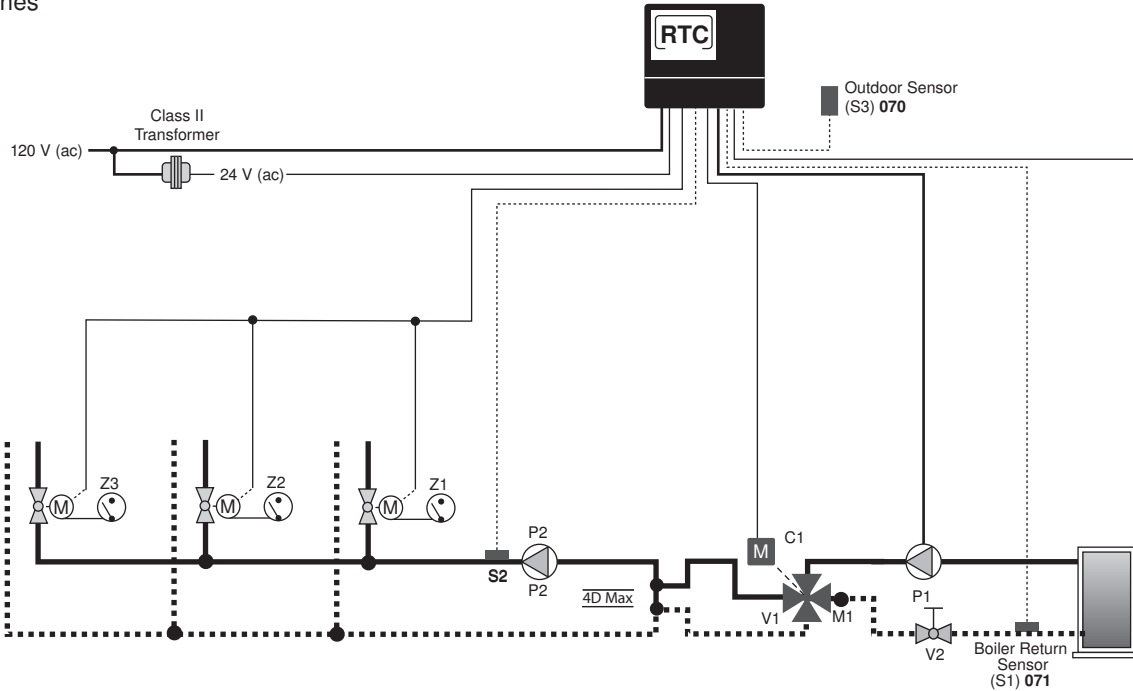

NOTES:

- 1) Install the boiler as indicated above for systems where return temperatures may be less than 135F and heating application only.
- 2) The Outdoor Sensor (S3) and the Mix Supply Sensor (S2) are required when the Outdoor Reset feature is selected. The mix sensor must be installed 10 pipe diameters downstream of the system pump, in the primary loop. The mix sensor must be secured to the surface of the pipe using a wire tie or similar device.
- 3) The by-pass piping, diverting valve and boiler circulator must be sized using the sizing charts found in Appendix B.
- 4) Closely spaced tees must connect the branch to the larger header. The Tee centerlines must be no greater than 4 times the larger header pipe diameter.
- 5) The diverting valve, V1, must be no greater than 11 linear feet of pipe from the Return Sensor, S1.
- 6) There shall be a MINIMUM of 4 linear feet of pipe between the By-pass Mix Point, M1, and the Return Sensor, S1.
- 7) The balancing valve in the boiler return line, V2, may be necessary in low head by-pass loop applications.
- 8) Expansion tanks, air scoops and other components left out for clarity.
- 9) Observe all applicable plumbing and electrical codes.

This diagram is for reference only. The installer or designer is responsible for the proper selection and design of the system.

A5. 4-way RTC in Primary/Secondary - Heating Only/No DHW; with/without Outdoor Reset (Electrical)

C1 = Mixing Valve Actuating Motor
 P1 = Boiler Circulator
 S1 = Boiler Return Sensor
 S2 = Mix Supply Sensor 071
 S3 = Outdoor Sensor 070
 Z1...Z3 = Zone Valves, Zone Relays,
 Thermostats or BMS Signal

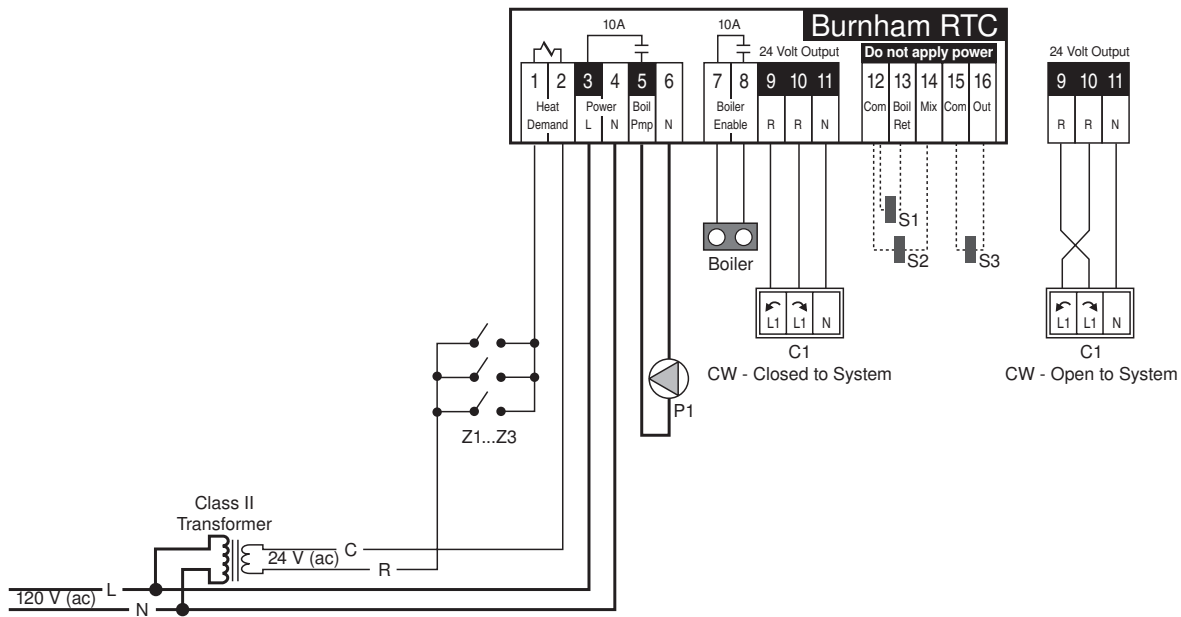

NOTES:

- 1) Refer to the I&O to determine correct valve orientation and actuator wiring.
- 2) 120 VAC supplying the RTC should be separate from the burner/boiler circuit.
- 3) Heat demand can be any electrical signal consisting of 24 - 240 VAC.
- 4) Use isolation relays for circulators greater than 1/3 HP. Use motor starters for 3 phase circulators.
- 5) System Pump (P3) to be operated by zone relay or other installer supplied device.

This diagram is for reference only. The installer or designer is responsible for the proper selection and design of the system.

A6. 4-way RTC in Primary/Secondary - Heating and DHW using Tankless Coil; with/without Outdoor Reset (Mechanical)

A1 = Tankless Coil or Storage Tank Aquastat
 C1 = Mixing Valve Actuating Motor
 M1 = By-Pass Mix Point
 P1 = Boiler Circulator
 P2 = Tankless System Circulator
 P3 = System Pump (runs on call for heat)
 R1 = Relay (Required with and without priority)
 R2 = Relay (Required for Priority)
 S1 = Boiler Return Sensor
 S2 = System Mix Sensor 071
 S3 = Outdoor Sensor 070
 ST1= Storage Tank
 TK1= Tankless Coil
 V1 = 4-Way Diverting Valve
 V2 = Ball Valve, Balancing Valve
 Z1...Z3 = Zones

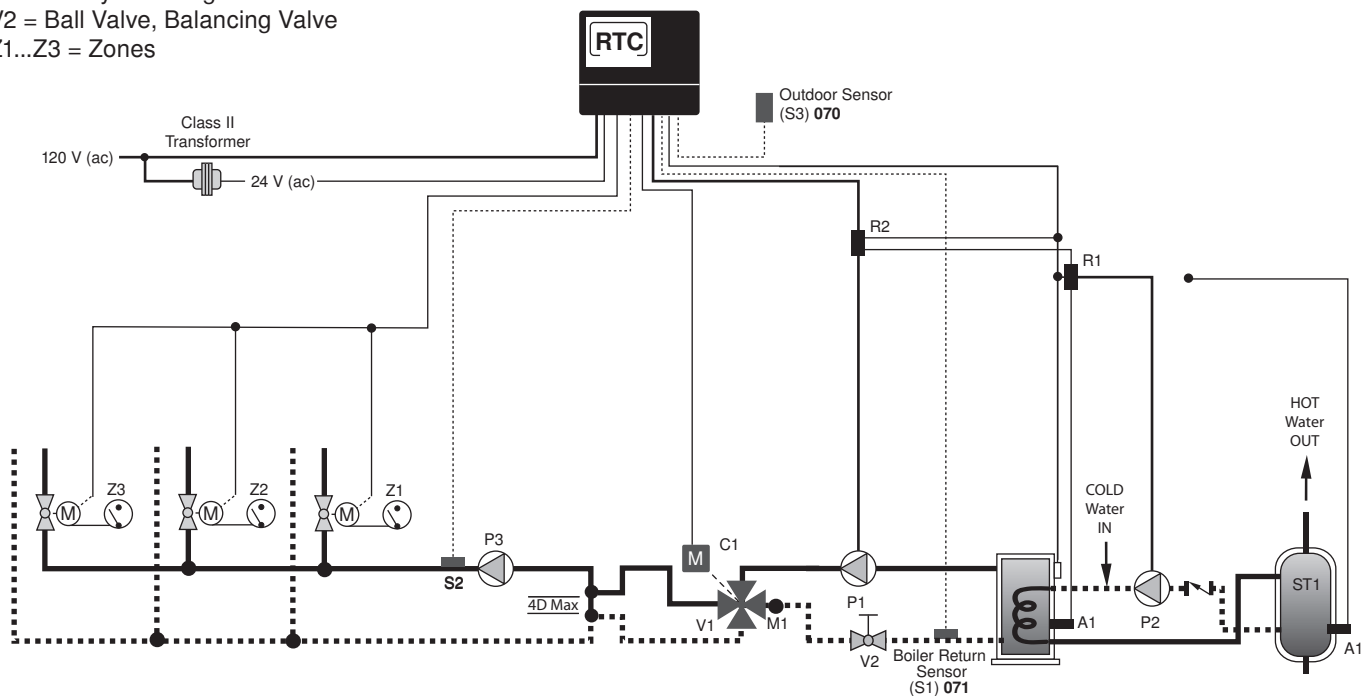

NOTES:

- 1) Install the boiler as indicated above for systems where return temperatures may be less than 135F and heating/DHW with tankless coils..
- 2) The Outdoor Sensor (S3) and the Mix Supply Sensor (S2) are required when the Outdoor Reset feature is selected. The mix sensor must be installed 10 pipe diameters downstream of the system pump, in the primary loop. The mix sensor must be secured to the surface of the pipe using a wire tie or similar device.
- 3) The by-pass piping, diverting valve and boiler circulator must be sized using the sizing charts found in Appendix B.
- 4) Closely spaced tees must connect the branch to the larger header. The Tee centerlines must be no greater than 4 times the larger header pipe diameter.
- 5) The diverting valve, V1, must be no greater than 11 linear feet of pipe from the Return Sensor, S1.
- 6) There shall be a MINIMUM of 4 linear feet of pipe between the By-pass Mix Point, M1, and the Return Sensor, S1.
- 7) The balancing valve in the boiler return line, V2, may be necessary in low head by-pass loop applications.
- 8) Domestic Hot Water must be tempered for safe usage. The tankless aquastat and/or storage tank aquastat (A1) are normally closed switches. Circuit breaks on temperature rise.
- 9) Expansion tanks, air scoops and other components left out for clarity.
- 10) Observe all applicable plumbing and electrical codes.

This diagram is for reference only. The installer or designer is responsible for the proper selection and design of the system.

A6. 4-way RTC in Primary/Secondary - Heating and DHW using Tankless Coil; with/without Outdoor Reset (Electrical)

- A1 = Tankless Coil or Storage Tank
Aquastat
- C1 = Mixing Valve Actuating Motor
- P1 = Boiler Circulator
- P2 = Tankless Coil System Circulator
- R1 = Relay (Required with and
without priority)
- R2 = Relay (Required for priority)
- S1 = Boiler Return Sensor
- S2 = Mix Supply Sensor 071
- S3 = Outdoor Sensor 070
- Z1...Z3 = Zone Valves, Zone Relays,
Thermostats or BMS Signal

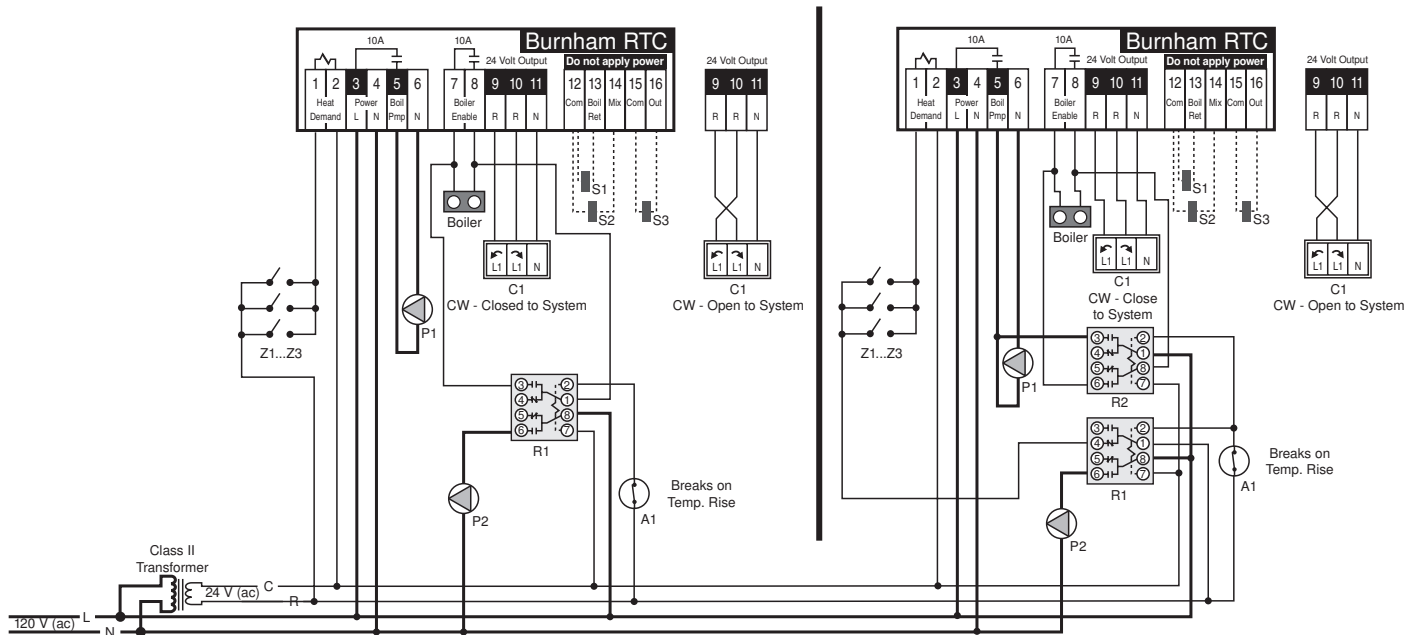

NOTES:

- 1) Refer to the I&O to determine correct valve orientation and actuator wiring.
- 2) 120 VAC supplying the RTC should be separate from the burner/boiler circuit.
- 3) Heat demand can be any electrical signal consisting of 24 - 240 VAC.
- 4) Use isolation relays for circulators greater than 1/3 HP. Use motor starters for 3 phase circulators.
- 5) The Outdoor Sensor (S3) and the Mix Supply Sensor (S2) are required if the Outdoor Reset feature is selected.
- 6) Connect the tankless aquastat (A1) if you are not using a storage tank. If you are using a storage tank with the tankless heater, use the storage tank aquastat.
- 7) System Pump (P3) to be operated by zone relay or other installer supplied device.

This diagram is for reference only. The installer or designer is responsible for the proper selection and design of the system.

A7. 4-way RTC in Primary/Secondary - Heating and DHW using Indirect Water Heater; with/without Outdoor Reset (Mechanical)

- A1 = Indirect Hot Water Aquastat
- C1 = Diverting Valve Actuating Motor
- M1 = By-Pass Mix Point
- P1 = Boiler Circulator
- P2 = Indirect Circulator
- P3 = System Pump (runs on call for heat)
- S1 = Boiler Return Sensor
- S2 = Mix Supply Sensor 071 (Required for Reset or Set-point Control)
- S3 = Outdoor Sensor 070 (Required for Reset Control)
- V1 = 4-Way Diverting Valve
- V2 = Ball Valve, Balancing Valve
- Z1...Z3 = Zones

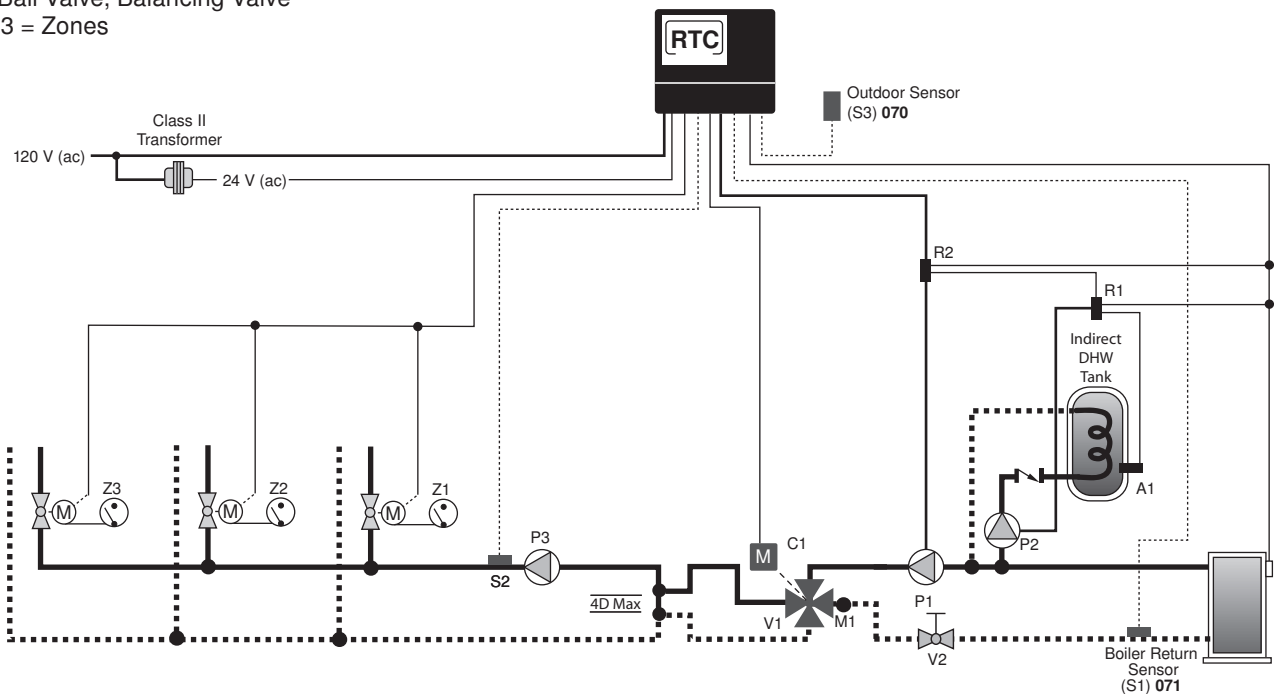

NOTES:

- 1) Install the boiler as indicated above for systems where return temperatures may be less than 135F and heating/DHW with an indirect water heater.
- 2) The Outdoor Sensor (S3) and the Mix Supply Sensor (S2) are required when the Outdoor Reset feature is selected. The mix sensor must be installed 10 pipe diameters downstream of the system pump, in the primary loop. The mix sensor must be secured to the surface of the pipe using a wire tie or similar device.
- 3) The by-pass piping, diverting valve and boiler circulator must be sized using the sizing charts found in Appendix B.
- 4) Closely spaced tees must connect the branch to the larger header. The Tee centerlines must be no greater than 4 times the larger header pipe diameter.
- 5) The diverting valve, V1, must be no greater than 11 linear feet of pipe from the Return Sensor, S1.
- 6) There shall be a MINIMUM of 4 linear feet of pipe between the By-pass Mix Point, M1, and the Return Sensor, S1.
- 7) The balancing valve in the boiler return line, V2, may be necessary in low head by-pass loop applications.
- 8) The indirect heater aquastat (A1) is a normally closed switch. Circuit breaks on temperature rise.
- 9) Expansion tanks, air scoops and other components left out for clarity.
- 10) Observe all applicable plumbing and electrical codes.

This diagram is for reference only. The installer or designer is responsible for the proper selection and design of the system.

A7. 4-way RTC in Primary/Secondary - Heating and DHW using Indirect Water Heater; with/without Outdoor Reset (Electrical)

- A1 = Indirect Hot Water Aquastat
- C1 = Mixing Valve Actuating Motor
- P1 = Boiler Circulator
- P2 = Indirect Circulator
- R1 = Relay (Required with and without priority)
- R2 = Relay (Required for priority)
- S1 = Boiler Return Sensor
- S2 = Mix Supply Sensor 071
- S3 = Outdoor Sensor 070
- Z1...Z3 = Zone Valves, Zone Relays, Thermostats or BMS Signal

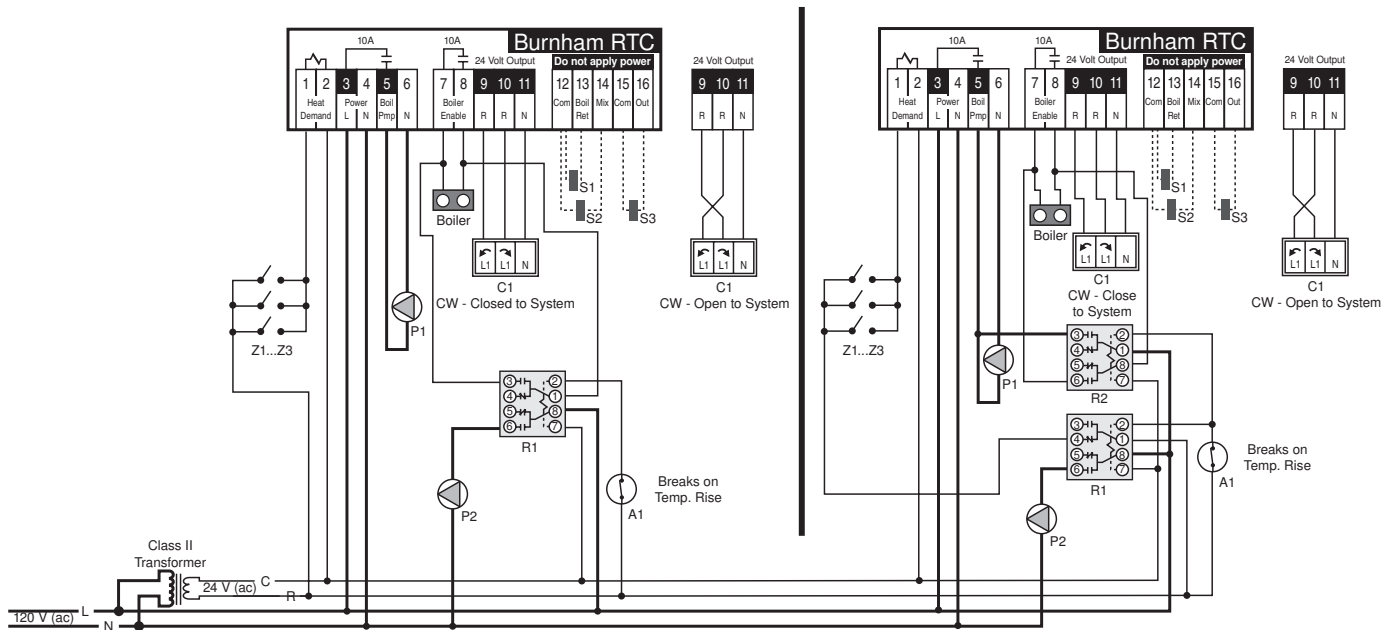

NOTES:

- 1) Refer to the I&O to determine correct valve orientation and actuator wiring.
- 2) 120 VAC supplying the RTC should be separate from the burner/boiler circuit.
- 3) Heat demand can be any electrical signal consisting of 24 - 240 VAC.
- 4) Use isolation relays for circulators greater than 1/3 HP. Use motor starters for 3 phase circulators.
- 5) The Outdoor Sensor (S3) and the Mix Supply Sensor (S2) are required if the Outdoor Reset feature is selected.
- 6) System Pump (P3) to be operated by zone relay or other installer supplied device.

This diagram is for reference only. The installer or designer is responsible for the proper selection and design of the system.

A8. 4-way RTC in Primary/Secondary - Heating and DHW using Indirect Water Heater on Primary Loop; without Outdoor Reset (Mechanical)

- A1 = Indirect Hot Water Aquastat
- C1 = Diverting Valve Actuating Motor
- M1 = By-Pass Mix Point
- P1 = Boiler Circulator
- P2 = Indirect Circulator
- P3 = System Pump (runs on call for heat)
- R1 = Relay
- S1 = Boiler Return Sensor
- V1 = 3-Way Diverting Valve
- V2 = Ball Valve, Balancing Valve
- V3 = Ball Valve, System Balancing
- Z1...Z3 = Zones

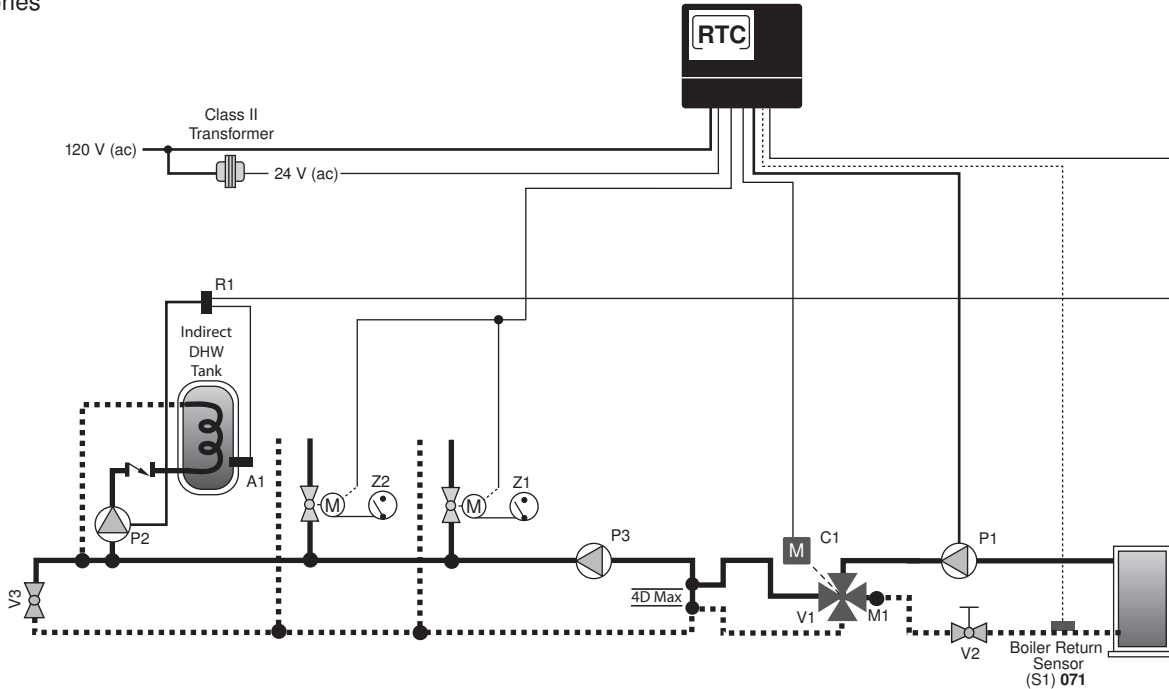

NOTES:

- 1) Install the boiler as indicated above for systems where return temperatures may be less than 135F and heating/DHW with an indirect water heater.
- 2) This arrangement is NOT recommended for outdoor reset applications. The reset temperature will constantly change DHW water performance.
- 3) The by-pass piping, diverting valve and boiler circulator must be sized using the sizing charts found in Appendix B.
- 4) A domestic hot water priority could be used provided the diversion from the heating system loop does not impact the system heater's performance.
- 5) Closely spaced tees must connect the branch to the larger header. The Tee centerlines must be no greater than 4 times the larger header pipe diameter.
- 6) The diverting valve, V1, must be no greater than 11 linear feet of pipe from the Return Sensor, S1.
- 7) There shall be a MINIMUM of 4 linear feet of pipe between the By-pass Mix Point, M1, and the Return Sensor, S1.
- 8) The balancing valve in the boiler return line, V2, may be necessary in low head by-pass loop applications.
- 9) The indirect heater aquastat (A1) is a normally closed switch. Circuit breaks on temperature rise.
- 10) Expansion tanks, air scoops and other components left out for clarity.
- 11) Observe all applicable plumbing and electrical codes.

This diagram is for reference only. The installer or designer is responsible for the proper selection and design of the system.

A8. 4-way RTC in Primary/Secondary - Heating and DHW using Indirect Water Heater on Primary Loop; without Outdoor Reset (Electrical)

- A1 = Indirect Hot Water Aquastat
- C1 = Mixing Valve Actuating Motor
- P1 = Boiler Circulator
- P2 = Indirect Circulator
- R1 = Relay
- S1 = Boiler Return Sensor
- Z1...Z3 = Zone Valves, Zone Relays,
Thermostats or BMS Signal

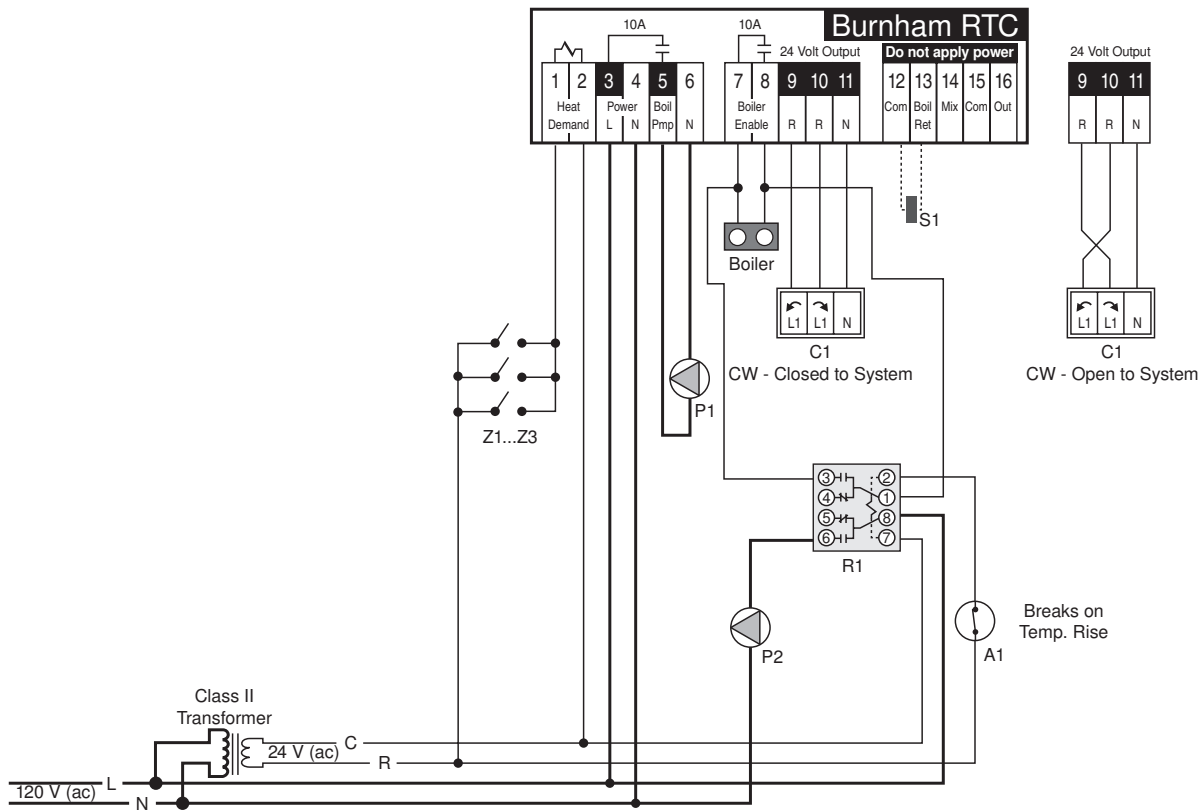

NOTES:

- 1) Refer to the I&O to determine correct valve orientation and actuator wiring.
- 2) 120 VAC supplying the RTC should be separate from the burner/boiler circuit.
- 3) Heat demand can be any electrical signal consisting of 24 - 240 VAC.
- 4) Use isolation relays for circulators greater than 1/3 HP. Use motor starters for 3 phase circulators.
- 5) System Pump (P3) to be operated by zone relay or other installer supplied device.

This diagram is for reference only. The installer or designer is responsible for the proper selection and design of the system.

A9. 3-way Multiple Boiler RTC in Primary/Secondary - Heating and DHW using Indirect Water Heater on Primary Loop; Using Sequencer with & without Outdoor Reset (Mechanical)

A1 = Indirect Hot Water Aquastat
 C1,C2 = Diverting Valve Actuating Motor
 M1,M2 = By-Pass Mix Point
 P1,P2 = Boiler Circulator
 P3 = System Pump (runs on call for heat)
 P4 = Indirect Circulator
 R1 = Relay
 S1,S2 = Boiler Return Sensor
 S3 = Mix Supply Sensor 071
 S4 = Outdoor Sensor 070
 V1,V2 = 3-Way Diverting Valve
 V3 = Ball Valve, Balancing Valve
 Z1...Z3 = Zones

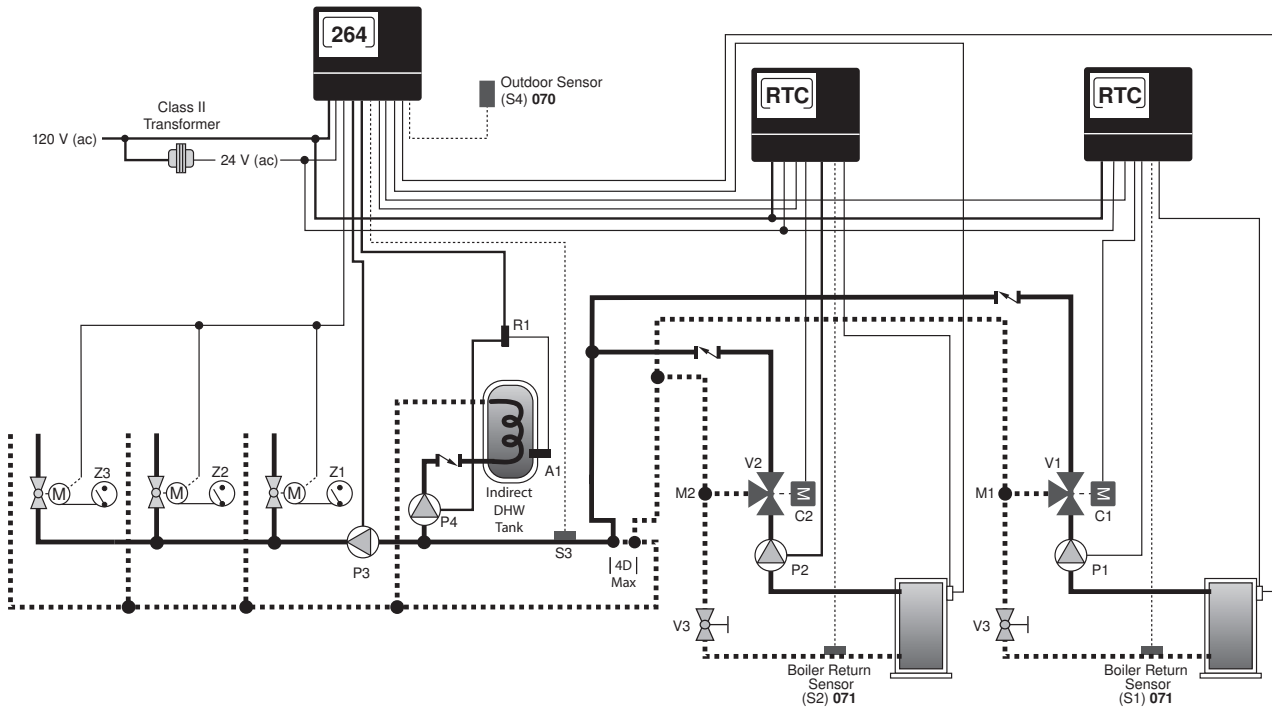

NOTES:

- 1) Install the boiler as indicated above for systems where return temperatures may be less than 135F and heating/DHW with an indirect water heater.
- 2) The Outdoor Sensor (S4) and the Mix Supply Sensor (S3) are required when the Outdoor Reset feature is selected. An appropriate sequencer must also be selected. The mix sensor must be installed 10 pipe diameters downstream of the system pump, in the primary loop. The mix sensor must be secured to the surface of the pipe using a wire tie or similar device.
- 3) The by-pass piping, diverting valve and boiler circulator must be sized using the sizing charts found in Appendix B.
- 4) A domestic hot water priority could be used provided the diversion from the heating system loop does not impact the system heater's performance.
- 5) Closely spaced tees must connect the branch to the larger header. The Tee centerlines must be no greater than 4 times the larger header pipe diameter.
- 6) The diverting valves, V1 & V2, must be no greater than 11 linear feet of pipe from the Return Sensor, S1 & S2.
- 7) There shall be a MINIMUM of 4 linear feet of pipe between the By-pass Mix Point, M1 & M2, and the Return Sensor, S1 & S2.
- 8) The balancing valves in the boiler return lines, V3, may be necessary in low head by-pass loop applications.
- 9) The indirect heater aquastat (A1) is a normally closed switch. Circuit breaks on temperature rise.
- 10) Expansion tanks, air scoops and other components left out for clarity.
- 11) Observe all applicable plumbing and electrical codes.

This diagram is for reference only. The installer or designer is responsible for the proper selection and design of the system.

A9. 3-way Multiple Boiler RTC in Primary/Secondary - Heating and DHW using Indirect Water Heater on Primary Loop; Using Sequencer with & without Outdoor Reset (Electrical)

A1 = Indirect Hot Water Aquastat
 C1,C2 = Mixing Valve Actuating Motor
 P1,P2 = Boiler Circulator
 P3 = System Pump (runs on call for heat)
 P4 = Indirect Circulator
 R1 = Relay
 S1,S2 = Boiler Return Sensor
 S3 = Mix Supply Sensor 071
 S4 = Outdoor Sensor 070
 Z1...Z3 = Zone Valves, Zone Relays, Thermostats or BMS Signal

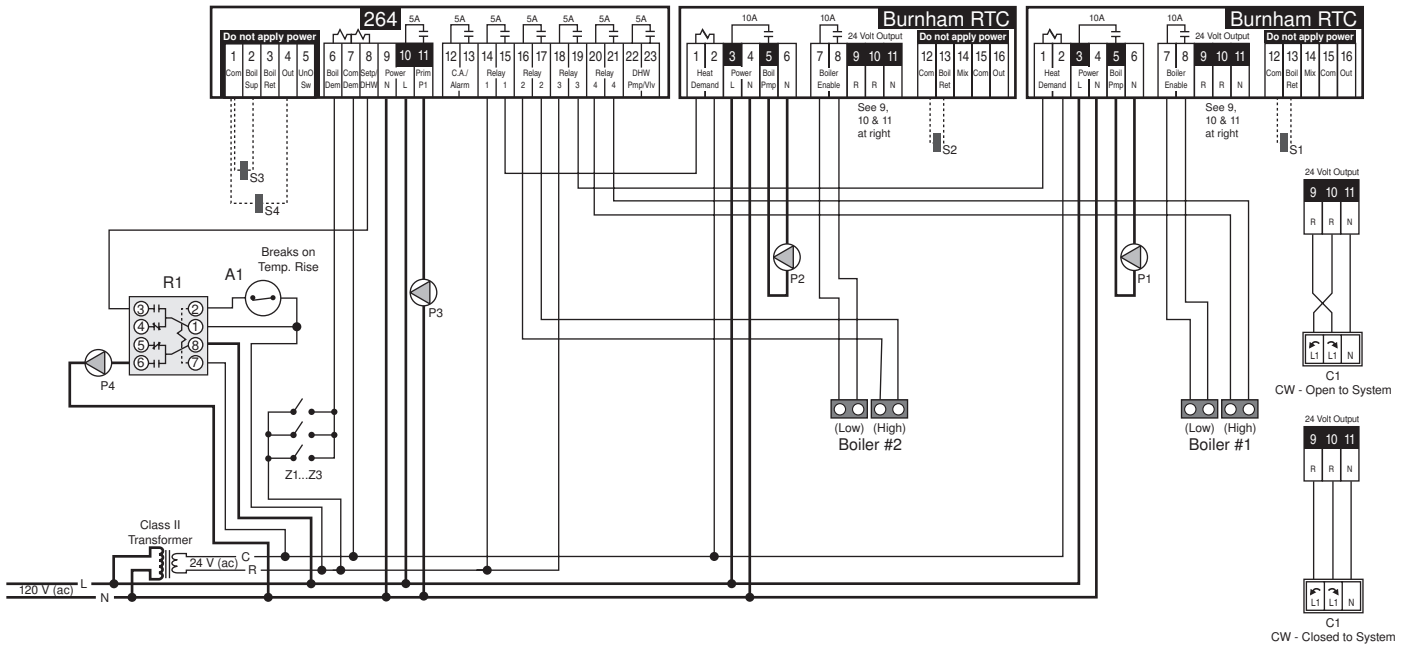

NOTES:

- 1) Refer to the I&O to determine correct valve orientation and actuator wiring.
- 2) 120 VAC supplying the RTC should be separate from the burner/boiler circuit.
- 3) Heat demand can be any electrical signal consisting of 24 - 240 VAC.
- 4) Use isolation relays for circulators greater than 1/3 HP. Use motor starters for 3 phase circulators.
- 5) System Pump (P3) to be operated by zone relay or other installer supplied device.

This diagram is for reference only. The installer or designer is responsible for the proper selection and design of the system.

A10. 4-way Multiple Boiler RTC in Primary/Secondary - Heating and DHW using Indirect Water Heater on Primary Loop; Using Sequencer with & without Outdoor Reset (Mechanical)

A1 = Indirect Hot Water Aquastat
 C1,C2 = Diverting Valve Actuating Motor
 M1,M2 = By-Pass Mix Point
 P1,P2 = Boiler Circulator
 P3 = System Pump (runs on call for heat)
 P4 = Indirect Circulator
 R1 = Relay
 S1,S2 = Boiler Return Sensor
 S3 = Mix Supply Sensor 071
 S4 = Outdoor Sensor 070
 V1,V2 = 3-Way Diverting Valve
 V3 = Ball Valve, Balancing Valve
 Z1...Z3 = Zones

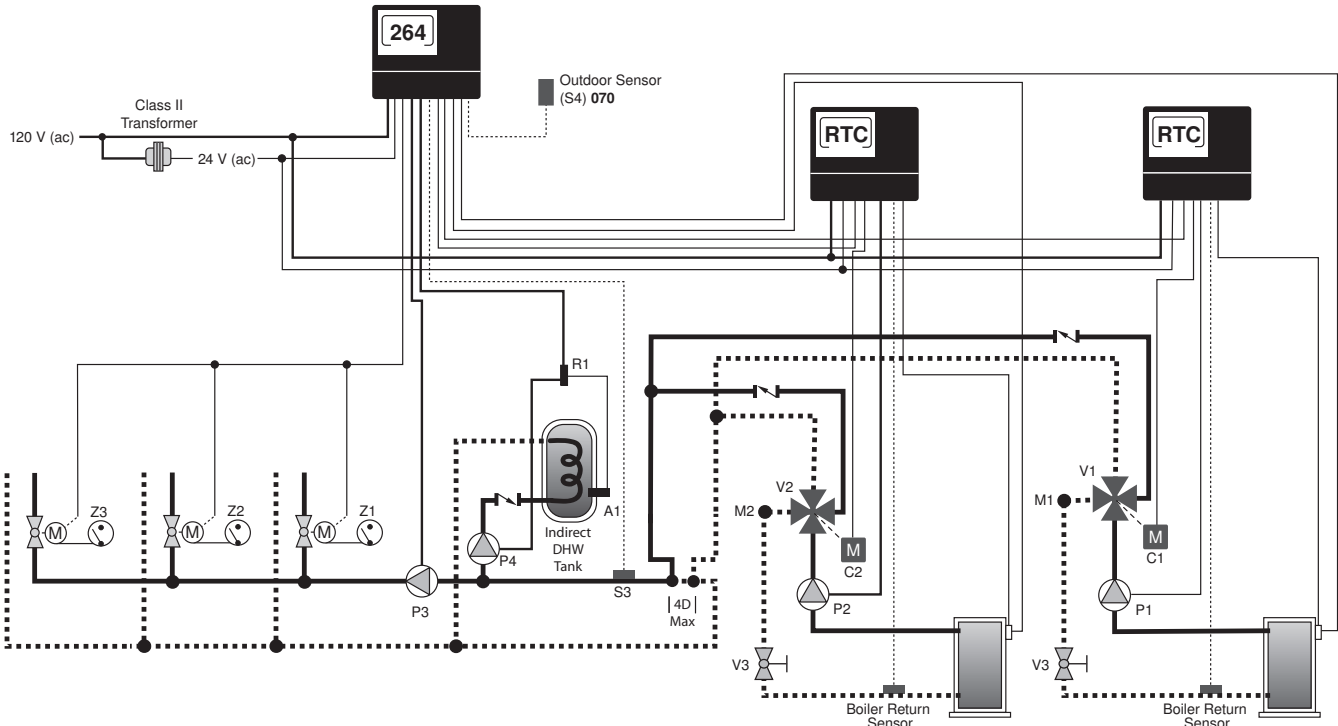

NOTES:

- 1) Install the boiler as indicated above for systems where return temperatures may be less than 135F and heating/DHW with an indirect water heater.
- 2) The Outdoor Sensor (S4) and the Mix Supply Sensor (S3) are required when the Outdoor Reset feature is selected. An appropriate sequencer must also be selected. The mix sensor must be installed 10 pipe diameters downstream of the system pump, in the primary loop. The mix sensor must be secured to the surface of the pipe using a wire tie or similar device.
- 3) The by-pass piping, diverting valve and boiler circulator must be sized using the sizing charts found in Appendix B.
- 4) A domestic hot water priority could be used provided the diversion from the heating system loop does not impact the system heater's performance.
- 5) Closely spaced tees must connect the branch to the larger header. The Tee centerlines must be no greater than 4 times the larger header pipe diameter.
- 6) The diverting valves, V1 & V2, must be no greater than 11 linear feet of pipe from the Return Sensor, S1 & S2.
- 7) There shall be a MINIMUM of 4 linear feet of pipe between the By-pass Mix Point, M1 & M2, and the Return Sensor, S1 & S2.
- 8) The balancing valves in the boiler return lines, V3, may be necessary in low head by-pass loop applications.
- 9) The indirect heater aquastat (A1) is a normally closed switch. Circuit breaks on temperature rise.
- 10) Expansion tanks, air scoops and other components left out for clarity.
- 11) Observe all applicable plumbing and electrical codes.

This diagram is for reference only. The installer or designer is responsible for the proper selection and design of the system.

A10. 4-way Multiple Boiler RTC in Primary/Secondary - Heating and DHW using Indirect Water Heater on Primary Loop; Using Sequencer with & without Outdoor Reset (Electrical)

A1 = Indirect Hot Water Aquastat
 C1,C2 = Mixing Valve Actuating Motor
 P1,P2 = Boiler Circulator
 P3 = System Pump (runs on call for heat)
 P4 = Indirect Circulator
 R1 = Relay
 S1,S2 = Boiler Return Sensor
 S3 = Mix Supply Sensor 071
 S4 = Outdoor Sensor 070
 Z1...Z3 = Zone Valves, Zone Relays, Thermostats or BMS Signal

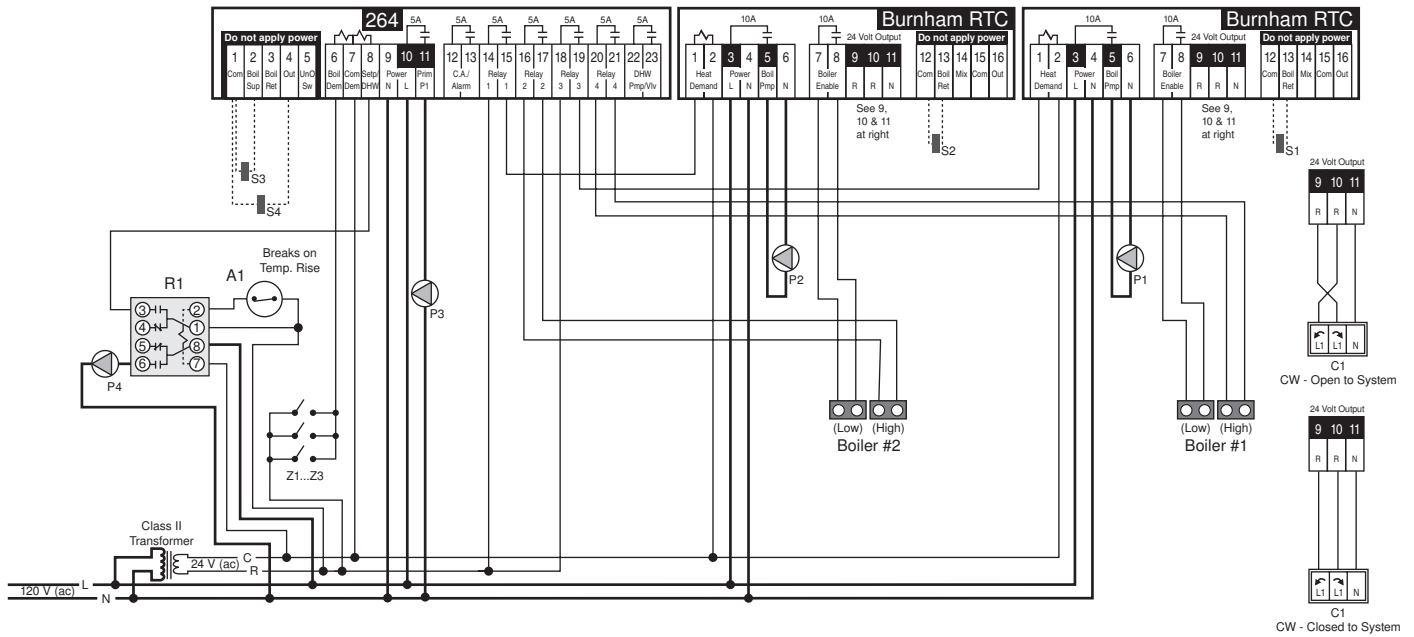

NOTES:

- 1) Refer to the I&O to determine correct valve orientation and actuator wiring.
- 2) 120 VAC supplying the RTC should be separate from the burner/boiler circuit.
- 3) Heat demand can be any electrical signal consisting of 24 - 240 VAC.
- 4) Use isolation relays for circulators greater than 1/3 HP. Use motor starters for 3 phase circulators.
- 5) System Pump (P3) to be operated by zone relay or other installer supplied device.

This diagram is for reference only. The installer or designer is responsible for the proper selection and design of the system.

Appendix B: Boiler Circulator and Diverting Valve Selection Charts

Appendix B1 ————— V9A Boiler Circulator and Diverting Valve Selection Chart, 20°F & 40°F ΔT, TACO —————

V9 Boiler Circulator Selection - TACO (40°F Differential)											
SIZE	IBR GROSS OUTPUT (MBH)	TOTAL GPM	Pipe Size	Boiler Recirculation 3-Way		Boiler Recirculation 4-Way		TACO Circulating Pump			
				Valve Size	Valve Part Number	Valve Size	Valve Part Number	Model No.	Imp "	HP	RPM
V903A	346	17	1.5"	1.0" NPT	80149013	1.0" NPT	80199016	007	N/A	1/25	3250
V904A	483	24	1.5"	1.25" NPT	80160356	1.25" NPT	80149017	0010	N/A	1/8	3250
V905A	646	32	1.5"	1.5" NPT	80160357	1.5" NPT	80149024	111C	N/A	1/8	1725
V906A	808	40	1.5"	1.5" NPT	80160357	1.5" NPT	80149024	121C	N/A	1/4	1725
V907A	959	48	2.0"	2.0" NPT	80160358	2.0" NPT	80149025	120C	N/A	1/6	1725
V908A	1110	56	2.0"	2.0" NPT	80160358	2.0" NPT	80149025	1611	4.1"	1/4	1750
V909A	1342	67	2.0"	2.0" NPT	80160358	2.0" NPT	80149025	122C	N/A	1/4	1725
V910A	1528	76	2.5"	*2.5" Flange	80160359	*2.5" Flange	80160366	121C	N/A	1/4	1725
V911A	1714	86	2.5"	*2.5" Flange	80160359	*2.5" Flange	80160366	131	N/A	1/3	1725
V912A	1900	95	2.5"	*2.5" Flange	80160359	*2.5" Flange	80160366	1635	4.5"	**1/2	1750

*Model F165-50 2Ω" 3-way valve or Model F450 2Ω" 4-way valve.

**Use Additional Relay for Single Phase Power. Use Motor Starter for 3 Phase Power.

V9 Boiler Circulator Selection - TACO (40°F Differential)											
SIZE	IBR GROSS OUTPUT (MBH)	TOTAL GPM	Pipe Size	Boiler Recirculation 3-Way		Boiler Recirculation 4-Way		TACO Circulating Pump			
				Valve Size	Valve Part Number	Valve Size	Valve Part Number	Model No.	Imp "	HP	RPM
V903A	346	17	1.5"	1.0" NPT	80149013	1.0" NPT	80199016	007	N/A	1/25	3250
V904A	483	24	1.5"	1.25" NPT	80160356	1.25" NPT	80149017	0010	N/A	1/8	3250
V905A	646	32	1.5"	1.5" NPT	80160357	1.5" NPT	80149024	111C	N/A	1/8	1725
V906A	808	40	1.5"	1.5" NPT	80160357	1.5" NPT	80149024	121C	N/A	1/4	1725
V907A	959	48	2.0"	2.0" NPT	80160358	2.0" NPT	80149025	120C	N/A	1/6	1725
V908A	1110	56	2.0"	2.0" NPT	80160358	2.0" NPT	80149025	1611	4.1"	1/4	1750
V909A	1342	67	2.0"	2.0" NPT	80160358	2.0" NPT	80149025	122C	N/A	1/4	1725
V910A	1528	76	2.5"	*2.5" Flange	80160359	*2.5" Flange	80160366	121C	N/A	1/4	1725
V911A	1714	86	2.5"	*2.5" Flange	80160359	*2.5" Flange	80160366	131	N/A	1/3	1725
V912A	1900	95	2.5"	*2.5" Flange	80160359	*2.5" Flange	80160366	1635	4.5"	**1/2	1750

*Model F165-50 2Ω" 3-way valve or Model F450 2Ω" 4-way valve.

**Use Additional Relay for Single Phase Power. Use Motor Starter for 3 Phase Power.

Appendix B2 ——— V9A Boiler Circulator and Diverting Valve Selection Chart, 20°F & 40°F ΔT, Grundfos ———

V9 Boiler Circulator Selection - Grundfos (20°F Differential)											
SIZE	IBR GROSS OUTPUT (MBH)	TOTAL GPM	Pipe Size	Boiler Recirculation 3-Way		Boiler Recirculation 4-Way		Grundfos Circulating Pump			
				Valve Size	Valve Part Number	Valve Size	Valve Part Number	Model No.	Imp "	HP	RPM
V903A	346	35	2.0"	1.5" NPT	80160357	1.5" NPT	80149024	UPS32-40/4	3.39	1/3	1667
V904A	483	48	2.0"	1.5" NPT	80160357	1.5" NPT	80149024	UPS32-80/2	2.52	**1/2	3400
V905A	646	65	2.0"	2" NPT	80160358	2" NPT	80149025	UPS40-80/4	4.86	**1/2	1587
V906A	808	81	2.5"	*2.5" Flange	80160359	*2.5" Flange	80160366	UPS40-80/4	4.86	**1/2	1587
V907A	959	96	2.5"	*2.5" Flange	80160359	*2.5" Flange	80160366	UPS50-80/4	4.97	**3/4	1607
V908A	1110	111	2.5"	*2.5" Flange	80160359	*2.5" Flange	80160366	UPS50-80/2	2.91	**3/4	3426
V909A	1342	134	3.0"	2.5" Flange	80160360	2.5" Flange	80149026	TP80-40/4	3.73	**1/2	1750
V910A	1528	153	3.0"	2.5" Flange	80160360	2.5" Flange	80149026	TP100-40/4	4.10	**1	1750
V911A	1714	171	3.0"	2.5" Flange	80160360	2.5" Flange	80149026	TP100-40/4	4.10	**1	1750
V912A	1900	190	4.0"	3.0" Flange	80160361	3.0" Flange	80160348	TP100-80/4	5.24	**2	1750

*Model F165-50 2Ω" 3-way valve or Model F450 2Ω" 4-way valve.
 **Use Additional Relay for Single Phase Power. Use Motor Starter for 3 Phase Power.

V9 Boiler Circulator Selection - Grundfos (40°F Differential)											
SIZE	IBR GROSS OUTPUT (MBH)	TOTAL GPM	Pipe Size	Boiler Recirculation 3-Way		Boiler Recirculation 4-Way		Grundfos Circulating Pump			
				Valve Size	Valve Part Number	Valve Size	Valve Part Number	Model No.	Imp "	HP	RPM
V903A	346	17	1.5"	1.0" NPT	80149013	1.0" NPT	80199016	UPS32-40/4	3.39	1/3	1594
V904A	483	24	1.5"	1.25" NPT	80160356	1.25" NPT	80149017	UPS32-40/4	3.39	1/3	1667
V905A	646	32	1.5"	1.5" NPT	80160357	1.5" NPT	80149024	UPS32-40/4	3.39	1/3	1712
V906A	808	40	1.5"	1.5" NPT	80160357	1.5" NPT	80149024	UPS32-80/2	2.52	**1/2	3400
V907A	959	48	2.0"	2.0" NPT	80160358	2.0" NPT	80149025	UPS32-80/2	2.52	**1/2	3400
V908A	1110	56	2.0"	2.0" NPT	80160358	2.0" NPT	80149025	UPS40-80/4	4.86	**1/2	1450
V909A	1342	67	2.0"	2.0" NPT	80160358	2.0" NPT	80149025	UPS40-80/4	4.86	**1/2	1587
V910A	1528	76	2.5"	*2.5" Flange	80160359	*2.5" Flange	80160366	UPS40-80/4	4.86	**1/2	1587
V911A	1714	86	2.5"	*2.5" Flange	80160359	*2.5" Flange	80160366	UPS40-80/4	4.86	**1/2	1688
V912A	1900	95	2.5"	*2.5" Flange	80160359	*2.5" Flange	80160366	UPS50-80/4	4.97	**3/4	1607

*Model F165-50 2Ω" 3-way valve or Model F450 2Ω" 4-way valve.
 **Use Additional Relay for Single Phase Power. Use Motor Starter for 3 Phase Power.

Appendix B3 — V9A Boiler Circulator and Diverting Valve Selection Chart, 20°F & 40°F ΔT, Bell and Gossett —

V9 Boiler Circulator Selection - Bell and Gossett (20°F Differential)											
SIZE	IBR GROSS OUTPUT (MBH)	TOTAL GPM	Pipe Size	Boiler Recirculation 3-Way		Boiler Recirculation 4-Way		Bell and Gossett Circulating Pump			
				Valve Size	Valve Part Number	Valve Size	Valve Part Number	Model No.	Imp "	HP	RPM
V903A	346	35	2.0"	1.5" NPT	80160357	1.5" NPT	80149024	PL-36 - 1.5"	Std.	1/6	3300
V904A	483	48	2.0"	1.5" NPT	80160357	1.5" NPT	80149024	PL-75 - 2"	Std.	1/6	3400
V905A	646	65	2.0"	2" NPT	80160358	2" NPT	80149025	PL-130 - 2"	Std.	**2/5	3200
V906A	808	81	2.5"	*2.5" Flange	80160359	*2.5" Flange	80160366	PL-130 - 2"	Std.	**2/5	3200
V907A	959	96	2.5"	*2.5" Flange	80160359	*2.5" Flange	80160366	PL-130 - 2"	Std.	**2/5	3200
V908A	1110	111	2.5"	*2.5" Flange	80160359	*2.5" Flange	80160366	Ser. 60, Mod. 610 - 2"	4"	**1/2	1750
V909A	1342	134	3.0"	2.5" Flange	80160360	2.5" Flange	80149026	Ser. 60, Mod. 610 - 2"	4"	**1/2	1750
V910A	1528	153	3.0"	2.5" Flange	80160360	2.5" Flange	80149026	Ser. 80, Mod. 3x3x7B	5"	**1	1750
V911A	1714	171	3.0"	2.5" Flange	80160360	2.5" Flange	80149026	Ser. 80, Mod. 3x3x7B	5"	**1	1750
V912A	1900	190	4.0"	3.0" Flange	80160361	3.0" Flange	80160348	Ser. 80, Mod. 3x3x7B	5"	**1	1750

*Model F165-50 2Ω" 3-way valve or Model F450 2Ω" 4-way valve.

**Use Additional Relay for Single Phase Power. Use Motor Starter for 3 Phase Power.

V9 Boiler Circulator Selection - Bell and Gossett (40°F Differential)											
SIZE	IBR GROSS OUTPUT (MBH)	TOTAL GPM	Pipe Size	Boiler Recirculation 3-Way		Boiler Recirculation 4-Way		Bell and Gossett Circulating Pump			
				Valve Size	Valve Part Number	Valve Size	Valve Part Number	Model No.	Imp "	HP	RPM
V903A	346	17	1.5"	1.0" NPT	80149013	1.0" NPT	80199016	NRF-33	Std.	1/15	2950
V904A	483	24	1.5"	1.25" NPT	80160356	1.25" NPT	80149017	PL-36	Std.	1/6	3300
V905A	646	32	1.5"	1.5" NPT	80160357	1.5" NPT	80149024	PL-36	Std.	1/6	3300
V906A	808	40	1.5"	1.5" NPT	80160357	1.5" NPT	80149024	PL-45	Std.	1/6	3300
V907A	959	48	2.0"	2.0" NPT	80160358	2.0" NPT	80149025	PL-75	Std.	1/6	3400
V908A	1110	56	2.0"	2.0" NPT	80160358	2.0" NPT	80149025	PL-75	Std.	1/6	3400
V909A	1342	67	2.0"	2.0" NPT	80160358	2.0" NPT	80149025	PL-130 - 2"	Std.	**2/5	3200
V910A	1528	76	2.5"	*2.5" Flange	80160359	*2.5" Flange	80160366	PL-130 - 2"	Std.	**2/5	3200
V911A	1714	86	2.5"	*2.5" Flange	80160359	*2.5" Flange	80160366	PL-130 - 2"	Std.	**2/5	3200
V912A	1900	95	2.5"	*2.5" Flange	80160359	*2.5" Flange	80160366	PL-130 - 2"	Std.	**2/5	3200

*Model F165-50 2Ω" 3-way valve or Model F450 2Ω" 4-way valve.

**Use Additional Relay for Single Phase Power. Use Motor Starter for 3 Phase Power.

Appendix B4 — V9A Boiler Circulator and Diverting Valve Selection Chart, 20°F & 40°F ΔT, Armstrong

V9 Boiler Circulator Selection - Armstrong (20°F Differential)											
SIZE	IBR GROSS OUTPUT (MBH)	TOTAL GPM	Pipe Size	Boiler Recirculation 3-Way		Boiler Recirculation 4-Way		Armstrong Circulating Pump			
				Valve Size	Valve Part Number	Valve Size	Valve Part Number	Model No.	Imp "	HP	RPM
V903A	346	35	2.0"	1.5" NPT	80160357	1.5" NPT	80149024	E-10	Full	1/6	---
V904A	483	48	2.0"	1.5" NPT	80160357	1.5" NPT	80149024	S-45	3.875	1/4	1800
V905A	646	65	2.0"	2" NPT	80160358	2" NPT	80149025	S-46	4.25	1/3	1200
V906A	808	81	2.5"	*2.5" Flange	80160359	*2.5" Flange	80160366	S-46	4.25	1/3	1200
V907A	959	96	2.5"	*2.5" Flange	80160359	*2.5" Flange	80160366	4380 3 x 3 x 6	5.04	1/3	1200
V908A	1110	111	2.5"	*2.5" Flange	80160359	*2.5" Flange	80160366	4380 3 x 3 x 6	5.567	**1/2	1200
V909A	1342	134	3.0"	2.5" Flange	80160360	2.5" Flange	80149026	4380 3 x 3 x 6	5.23	1/3	1200
V910A	1528	153	3.0"	2.5" Flange	80160360	2.5" Flange	80149026	4380 4 x 4 x 6	4.971	**1/2	1200
V911A	1714	171	3.0"	2.5" Flange	80160360	2.5" Flange	80149026	4380 4 x 4 x 6	5.371	**1/2	1200
V912A	1900	190	4.0"	3.0" Flange	80160361	3.0" Flange	80160348	4380 4 x 4 x 6	4.891	**1/2	1200

*Model F165-50 2Ω" 3-way valve or Model F450 2Ω" 4-way valve.

**Use Additional Relay for Single Phase Power Use Motor Starter for 3 Phase Power

V9 Boiler Circulator Selection - Armstrong (40°F Differential)											
SIZE	IBR GROSS OUTPUT (MBH)	TOTAL GPM	Pipe Size	Boiler Recirculation 3-Way		Boiler Recirculation 4-Way		Armstrong Circulating Pump			
				Valve Size	Valve Part Number	Valve Size	Valve Part Number	Model No.	Imp "	HP	RPM
V903A	346	17	1.5"	1.0" NPT	80149013	1.0" NPT	80199016	S-25	2.75	1/6	1800
V904A	483	24	1.5"	1.25" NPT	80160356	1.25" NPT	80149017	S-25	2.75	1/12	1800
V905A	646	32	1.5"	1.5" NPT	80160357	1.5" NPT	80149024	E-8	Full	1/6	3600
V906A	808	40	1.5"	1.5" NPT	80160357	1.5" NPT	80149024	S-35	3.375	1/6	1800
V907A	959	48	2.0"	2.0" NPT	80160358	2.0" NPT	80149025	S-46	3.375	1/4	1800
V908A	1110	56	2.0"	2.0" NPT	80160358	2.0" NPT	80149025	S-45	3.875	1/4	1800
V909A	1342	67	2.0"	2.0" NPT	80160358	2.0" NPT	80149025	S-46	3.875	1/3	1800
V910A	1528	76	2.5"	*2.5" Flange	80160359	*2.5" Flange	80160366	4380 3 x 3 x 6	4.998	1/3	1200
V911A	1714	86	2.5"	*2.5" Flange	80160359	*2.5" Flange	80160366	4380 3 x 3 x 6	4.677	1/3	1200
V912A	1900	95	2.5"	*2.5" Flange	80160359	*2.5" Flange	80160366	4380 3 x 3 x 6	5.019	1/3	1200

*Model F165-50 2Ω" 3-way valve or Model F450 2Ω" 4-way valve.

Appendix B5 — V11 Boiler Circulator and Diverting Valve Selection Chart, 20°F & 40°F ΔT, TACO

V11 Boiler Circulator Selection - TACO (20°F Differential)											
SIZE	IBR GROSS OUTPUT (MBH)	TOTAL GPM	Pipe Size	Boiler Recirculation 3-Way		Boiler Recirculation 4-Way		TACO Circulating Pump			
				Valve Size	Valve Part Number	Valve Size	Valve Part Number	Model No.	Imp "	HP	RPM
V1104	667	67	2.5"	2.0" NPT	80160358	2.0" NPT	80149025	KV1506	4.7"	**1	1750
V1105	857	86	2.5"	*2.5" Flange	80160359	*2.5" Flange	80160366	KV2006	4.5"	**1	1750
V1106	1069	107	2.5"	*2.5" Flange	80160359	*2.5" Flange	80160366	1635	4.8"	**3/4	1750
V1107	1281	128	3.0"	2.5" Flange	80160360	2.5" Flange	80149026	KV3006	4.4"	**1	1750
V1108	1517	152	3.0"	2.5" Flange	80160360	2.5" Flange	80149026	KV3006	5.0"	**1	1750
V1109	1729	173	4.0"	2.5" Flange	80160360	2.5" Flange	80149026	KV3007	5.5"	**1	1150
V1110	1941	194	4.0"	3.0" Flange	80160361	3.0" Flange	80160348	KV3007	5.5"	**1	1150
V1111	2154	215	4.0"	3.0" Flange	80160361	3.0" Flange	80160348	KV3007	6.0"	**1	1150
V1112	2334	233	4.0"	3.0" Flange	80160361	3.0" Flange	80160348	KV3007	6.2"	**1	1150
V1113	2503	250	4.0"	3.0" Flange	80160361	3.0" Flange	80160348	KV4007	5.6"	**1	1160
V1114	2730	273	4.0"	4.0" Flange	80160362	4.0" Flange	80160364	KV4007	5.8"	**1	1160
V1115	2957	296	4.0"	4.0" Flange	80160362	4.0" Flange	80160364	KV5007	5.7"	**1	1160
V1116	3126	313	5.0"	4.0" Flange	80160362	4.0" Flange	80160364	KV5007	5.5"	**1	1150
V1117	3353	335	5.0"	4.0" Flange	80160362	4.0" Flange	80160364	KV5007	5.8"	**1	1160
V1118	3580	358	5.0"	4.0" Flange	80160362	4.0" Flange	80160364	KV5007	5.9"	**1Ω	1160
V1119	3739	374	5.0"	5.0" Flange	80160363	5.0" Flange	80160365	CI3009	6.3"	**1Ω	1160
V1120	3957	396	5.0"	5.0" Flange	80160363	5.0" Flange	80160365	CI3009	6.5"	**1Ω	1160
V1121	4174	417	5.0"	5.0" Flange	80160363	5.0" Flange	80160365	CI4007	6.6"	**1Ω	1160
V1122	4334	433	5.0"	5.0" Flange	80160363	5.0" Flange	80160365	CI4007	6.7"	**2	1160
V1123	4551	455	5.0"	5.0" Flange	80160363	5.0" Flange	80160365	CI4007	6.9"	**2	1160

*Model F165-50 2Ω" 3-way valve or Model F450 2Ω" 4-way valve.

**Use Additional Relay for Single Phase Power. Use Motor Starter for 3 Phase Power.

V11 Boiler Circulator Selection - TACO (40°F Differential)

SIZE	IBR GROSS OUTPUT (MBH)	TOTAL GPM	Pipe Size	Boiler Recirculation 3-Way		Boiler Recirculation 4-Way		TACO Circulating Pump			
				Valve Size	Valve Part Number	Valve Size	Valve Part Number	Model No.	Imp "	HP	RPM
V1104	667	33	2.0"	1.5" NPT	80160357	1.5" NPT	80149024	111	N/A	1/8	1725
V1105	857	43	2.0"	1.5" NPT	80160357	1.5" NPT	80149024	120	N/A	1/6	1725
V1106	1069	53	2.0"	2.0" NPT	80160358	2.0" NPT	80149025	120	N/A	1/6	1725
V1107	1281	64	2.0"	2.0" NPT	80160358	2.0" NPT	80149025	121	N/A	**1/4	1725
V1108	1517	76	2.0"	2.0" NPT	80160358	2.0" NPT	80149025	131	N/A	1/3	1725
V1109	1729	86	2.5"	*2.5" Flange	80160359	*2.5" Flange	80160366	121	N/A	**1/4	1725
V1110	1941	97	2.5"	*2.5" Flange	80160359	*2.5" Flange	80160366	1635	4.5"	**1/2	1750
V1111	2154	108	2.5"	*2.5" Flange	80160359	*2.5" Flange	80160366	1635	4.8"	**3/4	1750
V1112	2334	117	3.0"	2.5" Flange	80160360	2.5" Flange	80149026	1635	4.9"	**3/4	1750
V1113	2503	125	3.0"	2.5" Flange	80160360	2.5" Flange	80149026	1635	5.2"	**3/4	1750
V1114	2730	137	3.0"	2.5" Flange	80160360	2.5" Flange	80149026	1635	5.5"	**1	1750
V1115	2957	148	3.0"	2.5" Flange	80160360	2.5" Flange	80149026	KV3006	4.9"	**1	1750
V1116	3126	156	3.0"	2.5" Flange	80160360	2.5" Flange	80149026	KV3006	5.1"	**1	1750
V1117	3353	168	3.0"	2.5" Flange	80160360	2.5" Flange	80149026	KV3007	5.9"	**1	1160
V1118	3580	179	4.0"	3.0" Flange	80160361	3.0" Flange	80160348	KV3007	5.6"	**1	1160
V1119	3739	187	4.0"	3.0" Flange	80160361	3.0" Flange	80160348	KV3007	5.6"	**1	1160
V1120	3957	198	4.0"	3.0" Flange	80160361	3.0" Flange	80160348	KV3007	5.7"	**1	1160
V1121	4174	209	4.0"	3.0" Flange	80160361	3.0" Flange	80160348	KV3007	5.9"	**1	1160
V1122	4334	217	4.0"	3.0" Flange	80160361	3.0" Flange	80160348	KV3007	6.1"	**1	1160
V1123	4551	228	4.0"	3.0" Flange	80160361	3.0" Flange	80160348	KV3007	6.3"	**1	1160

*Model F165-50 2Ω" 3-way valve or Model F450 2Ω" 4-way valve.

**Use Additional Relay for Single Phase Power. Use Motor Starter for 3 Phase Power.

Appendix B6 ——— V11 Boiler Circulator and Diverting Valve Selection Chart, 20°F & 40°F ΔT, Grundfos ———

V11 Boiler Circulator Selection - Grundfos (20°F Differential)											
SIZE	IBR GROSS OUTPUT (MBH)	TOTAL GPM	Pipe Size	Boiler Recirculation 3-Way		Boiler Recirculation 4-Way		Grundfos Circulating Pump			
				Valve Size	Valve Part Number	Valve Size	Valve Part Number	Model No.	Imp "	HP	RPM
V1104	667	67	2.5"	2.0" NPT	80160358	2.0" NPT	80149025	UPS40-80/4	4.86	**1/2	1587
V1105	857	86	2.5"	*2.5" Flange	80160359	*2.5" Flange	80160366	UPS40-80/4	4.86	**1/2	1688
V1106	1069	107	2.5"	*2.5" Flange	80160359	*2.5" Flange	80160366	UPS50-80/4	4.97	**3/4	1694
V1107	1281	128	3.0"	2.5" Flange	80160360	2.5" Flange	80149026	UPS50-80/2	2.91	**3/4	3426
V1108	1517	152	3.0"	2.5" Flange	80160360	2.5" Flange	80149026	TP100-40/4	4.1	**1	1750
V1109	1729	173	4.0"	2.5" Flange	80160360	2.5" Flange	80149026	TP100-40/4	4.1	**1	1750
V1110	1941	194	4.0"	3.0" Flange	80160361	3.0" Flange	80160348	---	---	---	---
V1111	2154	215	4.0"	3.0" Flange	80160361	3.0" Flange	80160348	---	---	---	---
V1112	2334	233	4.0"	3.0" Flange	80160361	3.0" Flange	80160348	---	---	---	---
V1113	2503	250	4.0"	3.0" Flange	80160361	3.0" Flange	80160348	UPS80-160/2	3.56	**3	3513
V1114	2730	273	4.0"	4.0" Flange	80160362	4.0" Flange	80160364	---	---	---	---
V1115	2957	296	4.0"	4.0" Flange	80160362	4.0" Flange	80160364	---	---	---	---
V1116	3126	313	5.0"	4.0" Flange	80160362	4.0" Flange	80160364	---	---	---	---
V1117	3353	335	5.0"	4.0" Flange	80160362	4.0" Flange	80160364	---	---	---	---
V1118	3580	358	5.0"	4.0" Flange	80160362	4.0" Flange	80160364	---	---	---	---
V1119	3739	374	5.0"	5.0" Flange	80160363	5.0" Flange	80160365	---	---	---	---
V1120	3957	396	5.0"	5.0" Flange	80160363	5.0" Flange	80160365	---	---	---	---
V1121	4174	417	5.0"	5.0" Flange	80160363	5.0" Flange	80160365	---	---	---	---
V1122	4334	433	5.0"	5.0" Flange	80160363	5.0" Flange	80160365	---	---	---	---
V1123	4551	455	5.0"	5.0" Flange	80160363	5.0" Flange	80160365	---	---	---	---

*Model F165-50 2Ω" 3-way valve or Model F450 2Ω" 4-way valve.

**Use Additional Relay for Single Phase Power. Use Motor Starter for 3 Phase Power.

V11 Boiler Circulator Selection - Grundfos (40°F Differential)

SIZE	IBR GROSS OUTPUT (MBH)	TOTAL GPM	Pipe Size	Boiler Recirculation 3-Way		Boiler Recirculation 4-Way		Grundfos Circulating Pump			
				Valve Size	Valve Part Number	Valve Size	Valve Part Number	Model No.	Imp "	HP	RPM
V1104	667	33	2.0"	1.5" NPT	80160357	1.5" NPT	80149024	UPS32-40/4	3.39	1/3	1667
V1105	857	43	2.0"	1.5" NPT	80160357	1.5" NPT	80149024	UPS32-80/2	2.52	**1/2	3281
V1106	1069	53	2.0"	2.0" NPT	80160358	2.0" NPT	80149025	UPS32-80/2	2.52	**1/2	3400
V1107	1281	64	2.0"	2.0" NPT	80160358	2.0" NPT	80149025	UPS40-80/4	4.86	**1/2	1587
V1108	1517	76	2.0"	2.0" NPT	80160358	2.0" NPT	80149025	UPS40-80/4	4.86	**1/2	1688
V1109	1729	86	2.5"	*2.5" Flange	80160359	*2.5" Flange	80160366	UPS40-80/4	4.86	**1/2	1688
V1110	1941	97	2.5"	*2.5" Flange	80160359	*2.5" Flange	80160366	UPS50-80/4	4.97	**3/4	1694
V1111	2154	108	2.5"	*2.5" Flange	80160359	*2.5" Flange	80160366	UPS50-80/4	4.97	**3/4	1694
V1112	2334	117	3.0"	2.5" Flange	80160360	2.5" Flange	80149026	UPS50-80/4	4.97	**3/4	1607
V1113	2503	125	3.0"	2.5" Flange	80160360	2.5" Flange	80149026	UPS50-80/4	4.97	**3/4	1694
V1114	2730	137	3.0"	2.5" Flange	80160360	2.5" Flange	80149026	UPS50-80/4	5.03	**1/2	1694
V1115	2957	148	3.0"	2.5" Flange	80160360	2.5" Flange	80149026	UPS50-160/2	4.1	**1	3395
V1116	3126	156	3.0"	2.5" Flange	80160360	2.5" Flange	80149026	UPS50-160/2	3.57	**3	3395
V1117	3353	168	3.0"	2.5" Flange	80160360	2.5" Flange	80149026	UPS50-160/2	3.57	**3	3513
V1118	3580	179	4.0"	3.0" Flange	80160361	3.0" Flange	80160348	UPS100-40/4	3.57	**3	1712
V1119	3739	187	4.0"	3.0" Flange	80160361	3.0" Flange	80160348	UPS100-40/4	3.57	**3	1712
V1120	3957	198	4.0"	3.0" Flange	80160361	3.0" Flange	80160348	UPS100-40/4	3.57	**3	1712
V1121	4174	209	4.0"	3.0" Flange	80160361	3.0" Flange	80160348	UPS80-160/2	3.57	**3	3513
V1122	4334	217	4.0"	3.0" Flange	80160361	3.0" Flange	80160348	UPS80-160/2	3.57	**3	3513
V1123	4551	228	4.0"	3.0" Flange	80160361	3.0" Flange	80160348	UPS80-160/2	3.57	**3	3513

*Model F165-50 2Ω" 3-way valve or Model F450 2Ω" 4-way valve.

**Use Additional Relay for Single Phase Power. Use Motor Starter for 3 Phase Power.

Appendix B7 ——— V11 Boiler Circulator and Diverting Valve Selection Chart, 20°F & 40°F ΔT, Bell and Gossett ———

V11 Boiler Circulator Selection - Bell and Gossett (20°F Differential)											
SIZE	IBR GROSS OUTPUT (MBH)	TOTAL GPM	Pipe Size	Boiler Recirculation 3-Way		Boiler Recirculation 4-Way		Bell and Gossett Circulating Pump			
				Valve Size	Valve Part Number	Valve Size	Valve Part Number	Model No.	Imp "	HP	RPM
V1104	667	67	2.5"	2.0" NPT	80160358	2.0" NPT	80149025	PL-130 - 2"	Std.	**2/5	3200
V1105	857	86	2.5"	*2.5" Flange	80160359	*2.5" Flange	80160366	PL-130 - 2"	Std.	**2/5	3200
V1106	1069	107	2.5"	*2.5" Flange	80160359	*2.5" Flange	80160366	Ser. 60, Mod. 610 - 2"	4"	**1/2	1750
V1107	1281	128	3.0"	2.5" Flange	80160360	2.5" Flange	80149026	Ser. 60, Mod. 610 - 2"	4"	**1/2	1750
V1108	1517	152	3.0"	2.5" Flange	80160360	2.5" Flange	80149026	Ser. 80, Mod. 3x3x7B	5"	**1	1750
V1109	1729	173	4.0"	2.5" Flange	80160360	2.5" Flange	80149026	Ser. 80, Mod. 3x3x7B	5"	**1	1750
V1110	1941	194	4.0"	3.0" Flange	80160361	3.0" Flange	80160348	Ser. 80, Mod. 4x4x7	5.5"	**3/4	1150
V1111	2154	215	4.0"	3.0" Flange	80160361	3.0" Flange	80160348	Ser. 80, Mod. 4x4x7	5.5"	**3/4	1150
V1112	2334	233	4.0"	3.0" Flange	80160361	3.0" Flange	80160348	Ser. 80, Mod. 5x5x7	5.25"	**3/4	1150
V1113	2503	250	4.0"	3.0" Flange	80160361	3.0" Flange	80160348	Ser. 80, Mod. 5x5x7	5.375"	**3/4	1150
V1114	2730	273	4.0"	4.0" Flange	80160362	4.0" Flange	80160364	Ser. 80, Mod. 5x5x7	5.25"	**3/4	1150
V1115	2957	296	4.0"	4.0" Flange	80160362	4.0" Flange	80160364	Ser. 80, Mod. 5x5x7	5.5"	**1	1150
V1116	3126	313	5.0"	4.0" Flange	80160362	4.0" Flange	80160364	Ser. 80, Mod. 5x5x7	5.5"	**1	1150
V1117	3353	335	5.0"	4.0" Flange	80160362	4.0" Flange	80160364	Ser. 80, Mod. 5x5x7	5.5"	**1	1150
V1118	3580	358	5.0"	4.0" Flange	80160362	4.0" Flange	80160364	Ser. 80, Mod. 5x5x7	5.875"	**1Ω	1150
V1119	3739	374	5.0"	5.0" Flange	80160363	5.0" Flange	80160365	Ser. 80, Mod. 5x5x7	6"	**1Ω	1150
V1120	3957	396	5.0"	5.0" Flange	80160363	5.0" Flange	80160365	Ser. 80, Mod. 5x5x7	6.5"	**1Ω	1150
V1121	4174	417	5.0"	5.0" Flange	80160363	5.0" Flange	80160365	Ser. 80, Mod. 5x5x7	6.5"	**1Ω	1150
V1122	4334	433	5.0"	5.0" Flange	80160363	5.0" Flange	80160365	Ser. 80, Mod. 6x6x7	5.625"	**1	1150
V1123	4551	455	5.0"	5.0" Flange	80160363	5.0" Flange	80160365	Ser. 80, Mod. 6x6x7	6"	**1Ω	1150

*Model F165-50 2Ω" 3-way valve or Model F450 2Ω" 4-way valve.

**Use Additional Relay for Single Phase Power. Use Motor Starter for 3 Phase Power.

V11 Boiler Circulator Selection - Bell and Gossett (40°F Differential)

SIZE	IBR GROSS OUTPUT (MBH)	TOTAL GPM	Pipe Size	Boiler Recirculation 3-Way		Boiler Recirculation 4-Way		Bell and Gossett Circulating Pump			
				Valve Size	Valve Part Number	Valve Size	Valve Part Number	Model No.	Imp "	HP	RPM
V1104	667	33	2.0"	1.5" NPT	80160357	1.5" NPT	80149024	PL-36 - 1-1/2"	Std.	1/6	3300
V1105	857	43	2.0"	1.5" NPT	80160357	1.5" NPT	80149024	PL-75	Std.	1/6	3400
V1106	1069	53	2.0"	2.0" NPT	80160358	2.0" NPT	80149025	PL-75	Std.	1/6	3400
V1107	1281	64	2.0"	2.0" NPT	80160358	2.0" NPT	80149025	PL-130 - 2"	Std.	**2/5	3200
V1108	1517	76	2.0"	2.0" NPT	80160358	2.0" NPT	80149025	PL-130 - 2"	Std.	**2/5	3200
V1109	1729	86	2.5"	*2.5" Flange	80160359	*2.5" Flange	80160366	PL-130 - 2"	Std.	**2/5	3200
V1110	1941	97	2.5"	*2.5" Flange	80160359	*2.5" Flange	80160366	PL-130 - 2"	Std.	**2/5	3200
V1111	2154	108	2.5"	*2.5" Flange	80160359	*2.5" Flange	80160366	Ser. 60, mod. 610 - 2"	4"	**1/2	1750
V1112	2334	117	3.0"	2.5" Flange	80160360	2.5" Flange	80149026	Ser. 60, mod. 610 - 2"	4"	**1/2	1750
V1113	2503	125	3.0"	2.5" Flange	80160360	2.5" Flange	80149026	Ser. 60, mod. 610 - 2"	4"	**1/2	1750
V1114	2730	137	3.0"	2.5" Flange	80160360	2.5" Flange	80149026	Ser. 80, mod. 3x3x7B	5"	**1	1750
V1115	2957	148	3.0"	2.5" Flange	80160360	2.5" Flange	80149026	Ser. 80, mod. 3x3x7B	5"	**1	1750
V1116	3126	156	3.0"	2.5" Flange	80160360	2.5" Flange	80149026	Ser. 80, mod. 3x3x7B	5"	**1	1750
V1117	3353	168	3.0"	2.5" Flange	80160360	2.5" Flange	80149026	Ser. 80, mod. 3x3x7B	5"	**1	1750
V1118	3580	179	4.0"	3.0" Flange	80160361	3.0" Flange	80160348	Ser. 80, mod. 3x3x7B	5"	**1	1750
V1119	3739	187	4.0"	3.0" Flange	80160361	3.0" Flange	80160348	Ser. 80, mod. 3x3x7B	5"	**1	1750
V1120	3957	198	4.0"	3.0" Flange	80160361	3.0" Flange	80160348	Ser. 80, mod. 3x3x7B	5"	**1	1750
V1121	4174	209	4.0"	3.0" Flange	80160361	3.0" Flange	80160348	Ser. 80, mod. 3x3x7B	5.5"	**1Ω	1750
V1122	4334	217	4.0"	3.0" Flange	80160361	3.0" Flange	80160348	Ser. 80, mod. 3x3x7B	5.5"	**1Ω	1750
V1123	4551	228	4.0"	3.0" Flange	80160361	3.0" Flange	80160348	Ser. 80, mod. 3x3x7B	5.5"	**1Ω	1750

*Model F165-50 2Ω" 3-way valve or Model F450 2Ω" 4-way valve.

**Use Additional Relay for Single Phase Power. Use Motor Starter for 3 Phase Power.

Appendix B8 V11 Boiler Circulator and Diverting Valve Selection Chart, 20°F & 40°F ΔT, Armstrong

V11 Boiler Circulator Selection - Armstrong (20°F Differential)											
SIZE	IBR GROSS OUTPUT (MBH)	TOTAL GPM	Pipe Size	Boiler Recirculation 3-Way		Boiler Recirculation 4-Way		Armstrong Circulating Pump			
				Valve Size	Valve Part Number	Valve Size	Valve Part Number	Model No.	Imp "	HP	RPM
V1104	667	67	2.5"	2.0" NPT	80160358	2.0" NPT	80149025	S-45	3.875	1/4	1800
V1105	857	86	2.5"	*2.5" Flange	80160359	*2.5" Flange	80160366	4380	4.529	1/3	1200
V1106	1069	107	2.5"	*2.5" Flange	80160359	*2.5" Flange	80160366	4380 3 x 3 x 6	5.418	**1/2	1200
V1107	1281	128	3.0"	2.5" Flange	80160360	2.5" Flange	80149026	4380 3 x 3 x 6	5.057	1/3	1200
V1108	1517	152	3.0"	2.5" Flange	80160360	2.5" Flange	80149026	4380 4 x 4 x 6	4.983	**1/2	1200
V1109	1729	173	4.0"	2.5" Flange	80160360	2.5" Flange	80149026	4380 4 x 4 x 6	5.01	**1/2	1200
V1110	1941	194	4.0"	3.0" Flange	80160361	3.0" Flange	80160348	4380 4 x 4 x 6	4.91	**1/2	1200
V1111	2154	215	4.0"	3.0" Flange	80160361	3.0" Flange	80160348	4380 4 x 4 x 6	5.149	**1/2	1200
V1112	2334	233	4.0"	3.0" Flange	80160361	3.0" Flange	80160348	4380 4 x 4 x 6	5.78	**3/4	1200
V1113	2503	250	4.0"	3.0" Flange	80160361	3.0" Flange	80160348	4380 4 x 4 x 6	5.90	**3/4	1200
V1114	2730	273	4.0"	4.0" Flange	80160362	4.0" Flange	80160364	4380 4 x 4 x 6	6.00	**3/4	1200
V1115	2957	296	4.0"	4.0" Flange	80160362	4.0" Flange	80160364	4380 5 x 5 x 8	7.03	**1.5	1200
V1116	3126	313	5.0"	4.0" Flange	80160362	4.0" Flange	80160364	4280 5 x 4 x 8	6.093	**1.5	1200
V1117	3353	335	5.0"	4.0" Flange	80160362	4.0" Flange	80160364	4280 5 x 4 x 8	6.20	**1.5	1200
V1118	3580	358	5.0"	4.0" Flange	80160362	4.0" Flange	80160364	4280 5 x 4 x 8	6.33	**1.5	1200
V1119	3739	374	5.0"	5.0" Flange	80160363	5.0" Flange	80160365	4280 5 x 4 x 8	6.418	**1.5	1200
V1120	3957	396	5.0"	5.0" Flange	80160363	5.0" Flange	80160365	4280 5 x 4 x 8	6.542	**1.5	1200
V1121	4174	417	5.0"	5.0" Flange	80160363	5.0" Flange	80160365	4380 6 x 6 x 8	6.614	**1.5	1200
V1122	4334	433	5.0"	5.0" Flange	80160363	5.0" Flange	80160365	4380 6 x 6 x 8	6.666	**3.0	1200
V1123	4551	455	5.0"	5.0" Flange	80160363	5.0" Flange	80160365	4380 6 x 6 x 8	6.56	**3.0	1200

*Model F165-50 2Ω" 3-way valve or Model F450 2Ω" 4-way valve.

**Use Additional Relay for Single Phase Power. Use Motor Starter for 3 Phase Power.

V11 Boiler Circulator Selection - Armstrong (40°F Differential)

SIZE	IBR GROSS OUTPUT (MBH)	TOTAL GPM	Pipe Size	Boiler Recirculation 3-Way		Boiler Recirculation 4-Way		Armstrong Circulating Pump			
				Valve Size	Valve Part Number	Valve Size	Valve Part Number	Model No.	Imp "	HP	RPM
V1104	667	33	2.0"	1.5" NPT	80160357	1.5" NPT	80149024	E-8	Full	1/6	3600
V1105	857	43	2.0"	1.5" NPT	80160357	1.5" NPT	80149024	S-35	3.375	1/6	1800
V1106	1069	53	2.0"	2.0" NPT	80160358	2.0" NPT	80149025	S-45	3.875	1/4	1800
V1107	1281	64	2.0"	2.0" NPT	80160358	2.0" NPT	80149025	S-45	3.875	1/4	1800
V1108	1517	76	2.0"	2.0" NPT	80160358	2.0" NPT	80149025	S-46	4.25	1/3	1800
V1109	1729	86	2.5"	*2.5" Flange	80160359	*2.5" Flange	80160366	S-46	4.25	1/3	1800
V1110	1941	97	2.5"	*2.5" Flange	80160359	*2.5" Flange	80160366	4380 3 x 3 x 6	5.147	1/3	1200
V1111	2154	108	2.5"	*2.5" Flange	80160359	*2.5" Flange	80160366	4380 3 x 3 x 6	5.579	**1/2	1200
V1112	2334	117	3.0"	2.5" Flange	80160360	2.5" Flange	80149026	4380 3 x 3 x 6	5.119	1/3	1200
V1113	2503	125	3.0"	2.5" Flange	80160360	2.5" Flange	80149026	4380 3 x 3 x 6	5.00	1/3	1200
V1114	2730	137	3.0"	2.5" Flange	80160360	2.5" Flange	80149026	4380 4 x 4 x 6	4.569	1/3	1200
V1115	2957	148	3.0"	2.5" Flange	80160360	2.5" Flange	80149026	4380 4 x 4 x 6	4.92	**1/2	1200
V1116	3126	156	3.0"	2.5" Flange	80160360	2.5" Flange	80149026	4380 4 x 4 x 6	5.168	**1/2	1200
V1117	3353	168	3.0"	2.5" Flange	80160360	2.5" Flange	80149026	4380 4 x 4 x 6	5.520	**3/4	1200
V1118	3580	179	4.0"	3.0" Flange	80160361	3.0" Flange	80160348	4380 4 x 4 x 6	4.654	1/3	1200
V1119	3739	187	4.0"	3.0" Flange	80160361	3.0" Flange	80160348	4380 4 x 4 x 6	4.808	1/3	1200
V1120	3957	198	4.0"	3.0" Flange	80160361	3.0" Flange	80160348	4380 4 x 4 x 6	5.03	**1/2	1200
V1121	4174	209	4.0"	3.0" Flange	80160361	3.0" Flange	80160348	4380 4 x 4 x 6	5.21	**1/2	1200
V1122	4334	217	4.0"	3.0" Flange	80160361	3.0" Flange	80160348	4380 4 x 4 x 66.19	6.19	**1/2	1200
V1123	4551	228	4.0"	3.0" Flange	80160361	3.0" Flange	80160348	4380 4 x 4 x 6	5.520	**3/4	1200

*Model F165-50 2Ω" 3-way valve or Model F450 2Ω" 4-way valve.

**Use Additional Relay for Single Phase Power. Use Motor Starter for 3 Phase Power.

Appendix C: Valve and Actuator Mounting Instructions

Application

For use with ESBE ½" to 6" 3-Way and 4-Way rotary valves for mixing and diverting applications. Use with 24Vac 3-point "floating" signal controller.

Mounting the Motor

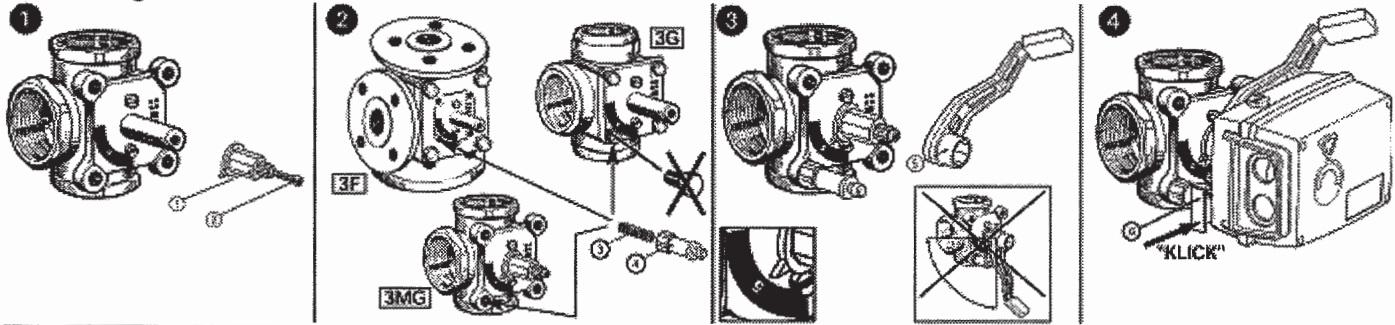

1. Place drive sleeve ① onto shaft and secure with bolt ②. Check that the valve is in mid-position (sleeve pointer set to position 5 on scaleplate).
2. Mount threaded stud ③ in one of the threaded holes. For 1½" and 2" valves replace one of the cover bolts with the threaded rod. Tighten mounting piece ④ onto threaded rod.
3. Mount handle ⑤ over drive sleeve set pointer to 5 on the scale plate. Handle must be mounted opposite to the pointer of the drive sleeve.
4. Mount motor onto sleeve so that the mounting piece m fits into the locking piece o. Push locking piece to lock in place. Labels are supplied to indicate the direction of rotation. Determine the direction of rotation and mount the correct label under the plastic front cover of motor.

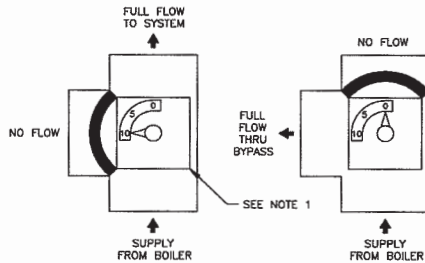

CLOCKWISE (CW) = CLOSED TO SYSTEM
COUNTER-CLOCKWISE (CCW) = OPEN TO SYSTEM



NOTE:
1. VALVE POSITIONING LABEL ON BOTH SIDES OF PLATE.
SELECT DIAL FACE FOR CORRECT ORIENTATION.

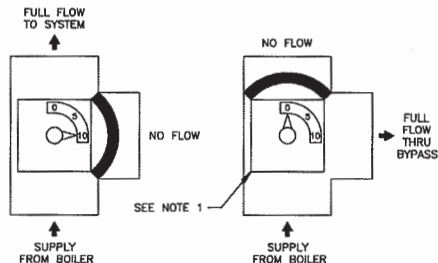

CLOCKWISE (CW) = OPEN TO SYSTEM
COUNTER-CLOCKWISE (CCW) = CLOSED TO SYSTEM

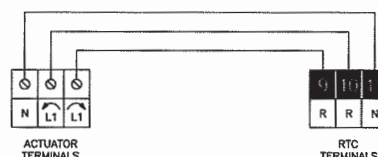

NOTE:
1. VALVE POSITIONING LABEL ON BOTH SIDES OF PLATE.
SELECT DIAL FACE FOR CORRECT ORIENTATION.

Manual Operation

Always disconnect power before operating by hand. Note position of drive sleeve pointer to be returned to. Depress the gray button, "A", on the side to release the handle. The valve can now be operated manually. **Never manually operate when gears are engaged.**

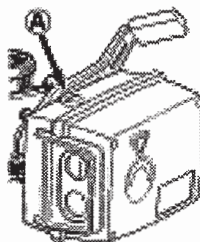

Adjusting Cams

Always disconnect power before making adjustments.

Typically, cam adjustment is not necessary. Before attempting cam adjustment, check valve pointer travel. Pointer travel should stay within 90° arc between "0" and "10" on positioning label. It is advisable to remove manual valve handle before performing adjustments to avoid any gear damage. Remove actuator cover and pull red indicator off of drive shaft to access cams. Fit screwdriver into slot of cam and rotate to desired position. Topmost cam operates auxiliary switch (upper switch) and is not used. This cam can be moved out of the way to gain access to cams below. Middle and bottom cams determine degree of rotation (30° to 180°). Adjust middle cam so end switch is made when valve is fully closed to system (pointer at "0"). Adjust bottom cam so end switch is made when valve is fully open to system (pointer at "10"). Reinstall valve handle, indicator and cover. Depress "Test" switch on RTC control to test for proper valve travel and rotation before attempting to use valve.

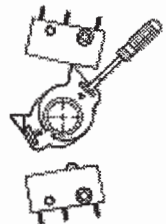

Technical Data

RTC Return Temperature Control

Literature	—	RTC Return Temperature Control manual.
Control	—	Microprocessor PID control; This is not a safety (limit) control .
Packaged weight	—	3.1 lb. (1420 g), Enclosure A, black PVC plastic
Dimensions	—	6-5/8" H x 7-9/16" W x 2-13/16" D (170 x 193 x 72 mm)
Approvals	—	CSA C US, meets ICES & FCC regulations for EMI/RFI.
Ambient conditions	—	Indoor use only, 32 to 104°F (0 to 40°C), < 90% RH non-condensing.
Power supply	—	120 V ±10% 50/60 Hz 1300 VA
Motor Relay	—	24 V (ac) 0.34 A 8 VA
Relays	—	240 V (ac) 10 A 1/3 hp, pilot duty 240 VA
Demand	—	20 to 260 V (ac) 2 VA
Sensors included	—	1 Well Sensor.
Optional devices	—	Outdoor Sensor 070, Universal Sensor 071.

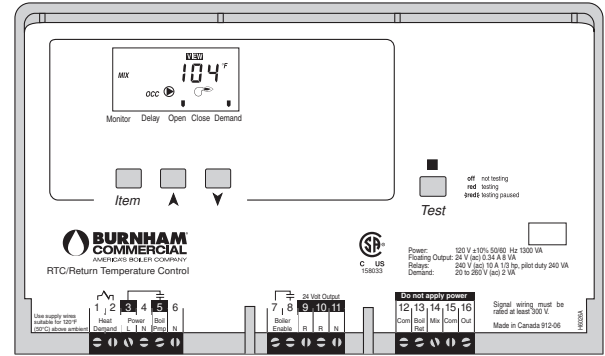

Limited Warranty

FOR RTC/Return TEMPERATURE CONTROL

Subject to the terms and conditions set forth below, Burnham Commercial, America's Boiler Co., Lancaster, Pennsylvania hereby extends the following limited warranties to the original owner of a RTC/Return Temperature Control manufactured and shipped on or after May 1, 2003:

Burnham Commercial warrants to the original owner that its RTC/Return Temperature Control complies at the time of manufacture with recognized hydronic industry standards and requirements then in effect, and will be free of defects in material and workmanship under normal usage for a period of two years from the date of original installation. If any part of the control is found to be defective in material or workmanship during this two year period, Burnham Commercial will, at its option, repair or replace the defective part.

ADDITIONAL TERMS AND CONDITIONS

1. **Applicability:** The limited warranties set forth above are extended only to the original owner at the original place of installation within the United States and Canada.
2. **Proper Installation:** The warranties extended by Burnham Commercial are conditioned upon the installation of the RTC/Return Temperature Control in strict compliance with Burnham Commercial installation instructions. Burnham Commercial specifically disclaims liability of any kind caused by or relating to improper installation.
3. **Proper Use and Maintenance:** The warranties extended by Burnham Commercial are conditioned upon the use of the RTC/Return Temperature Control for its intended purposes and its maintenance in accordance with Burnham Commercial recommendations and hydronics industry standards. These warranties will be inapplicable if the RTC/Return Temperature Control is subjected to unauthorized modification, or is damaged as a result of being otherwise improperly operated or serviced.
4. **Removal and Installation:** These warranties do not cover expenses of removal or reinstallation. The owner is responsible for the cost of removing and reinstalling any defective part and its replacements and all labor and material connected therewith.
5. **Exclusive Remedy:** Burnham Commercial's obligation for any breach of these warranties is limited to the repair or replacement of its parts in accordance with the terms and conditions of these warranties.
6. **Limitation of Damages:** Under no circumstances shall Burnham Commercial be liable for incidental, indirect, special or consequential damages of any kind whatsoever under these warranties, including, but not limited to, injury or damage to persons or property and damages for loss of use, inconvenience or loss of time. Burnham Commercial's liability under these warranties shall under no circumstances exceed the purchase price paid by the owner for RTC/Return Temperature Control involved. Some states do not allow the exclusion or limitation of incidental or consequential damages, so the above limitation or exclusion may not apply to you.
7. **Limitation of Warranties:** These warranties set forth the entire obligation of Burnham with respect to any defect in RTC/Return Temperature Control and Burnham Commercial shall have no express obligations, responsibilities or liabilities of any kind whatsoever other than those set forth herein. These warranties are given in lieu of all other express warranties.

ALL APPLICABLE IMPLIED WARRANTIES, IF ANY, INCLUDING ANY WARRANTY OF MERCHANTABILITY OR FITNESS FOR A PARTICULAR PURPOSE ARE EXPRESSLY LIMITED IN DURATION TO A PERIOD OF TWO YEARS.

Some states do not allow limitation on how long an implied warranty lasts, so the above limitation may not apply to you.

PROCEDURE FOR OBTAINING WARRANTY SERVICE

Upon discovery of a condition believed to be related to a defect in material or workmanship covered by these warranties, the owner should notify the installer, who will in turn notify the distributor. If this action is not possible or does not produce a prompt response, the owner should write to Burnham Commercial, America's Boiler Company, at P.O. Box 3939, Lancaster, PA 17604-3939, giving full particulars in support of the claim. The owner is required to make available for inspection by Burnham Commercial or its representative the parts claimed to be defective and, if requested by Burnham, to ship these parts prepaid to Burnham Commercial at the above address for inspection or repair. In addition, the owner agrees to make all reasonable efforts to settle any disagreement arising in connection with a claim before resorting to legal remedies in the courts.

THIS WARRANTY GIVES YOU SPECIFIC LEGAL RIGHTS AND YOU MAY ALSO HAVE OTHER RIGHTS WHICH VARY FROM STATE TO STATE.

TWO YEAR LIMITED WARRANTY ON RTC/Return TEMPERATURE CONTROL



Burnham Commercial
P.O. Box 3939
Lancaster, PA. 17604-3939
(888) 791-3790 Fax. (877) 501-5211