

Boiler Energy Management System

FW 200

for boilers with Heatronic 3



BOSCH

Installation and Operating Instructions

Overview of controls and symbols

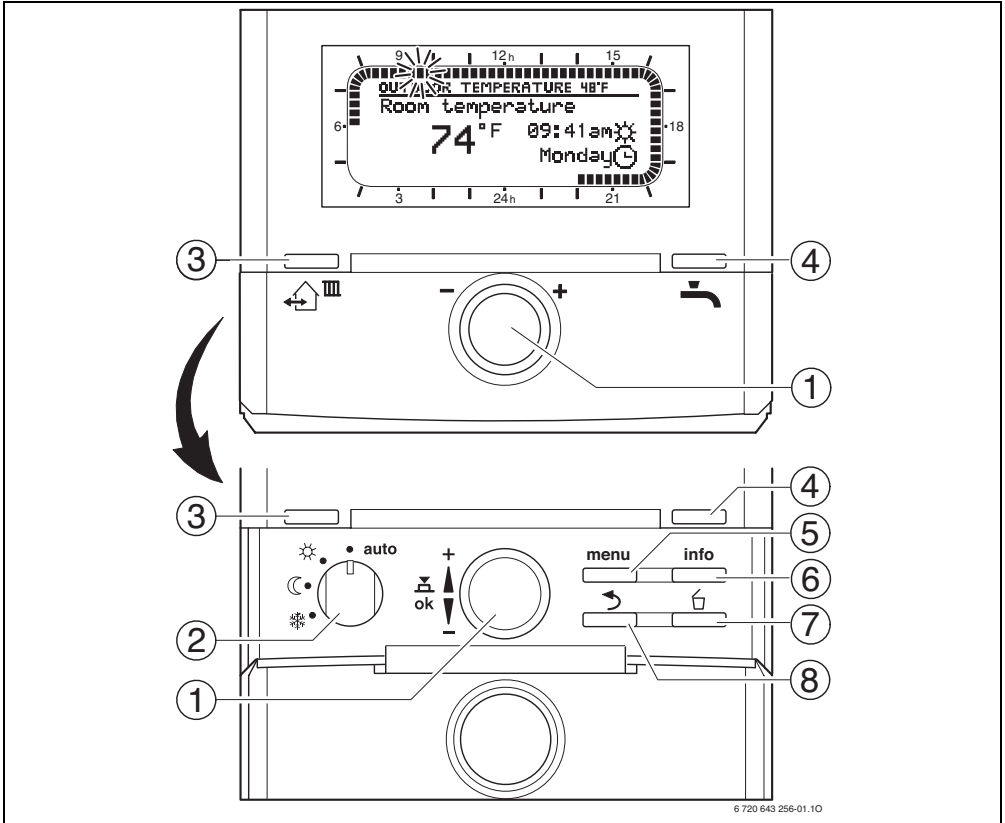

Fig. 1 Controls

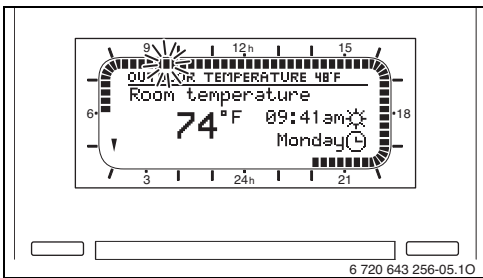

Fig. 2 Default display for heating circuit 1 (example for wall mounting)

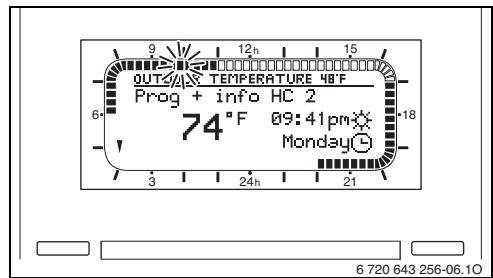



































Fig. 3 Default display for heating circuit 2 (example for wall mounting)

Controls	
1	Turning dial  in + direction (clockwise): scrolls menu/information up or increases setting value
	Turning dial  in - direction (counter-clockwise): scrolls menu/information down or decreases setting value
	Pressing dial  : opens menu or confirms setting/value or switches heating zone
2	Mode selector for heating zones:
	 Automatic operation mode
	 Continuous Comfort mode
	 Continuous Economy mode
3	 : Jumps forward to the next switch point and the associated operating mode  = Comfort,  = Economy,  = Frost Protection for the heating zone.
	 : Activate DHW mode immediately. The DHW tank is heated to the desired temperature for 60 minutes or, with combi boilers, Comfort mode is activated for 30 minutes.
5	 : Open/close menu
6	 : Show settings
7	 : Delete/reset setting
8	 : Return to next menu up

Tab. 1

Symbols	
	Current room temperature (only when mounted on the wall in the living space)
	Flashing segment: Time now (between 01:45pm and 02:00pm) (13:45 - 14:00)
	Solid segments: time set for operating mode  = Comfort today (1 segment = 15 min)
	Empty segments: time set for operating mode  = Economy today (1 segment = 15 min)
	No segments: time set for operating mode  = Frost Protection today (1 segment = 15 min)
	Operating mode Comfort for heating zone
	Operating mode Economy for heating zone
	Operating mode Frost Protection for heating zone
	Automatic mode for heating zone
	Vacation mode
	Burner operation on display for heating zone 1
	Burner operation on display for heating zone 2
	Return to previous menu up
	Other display information (menu options) are available. They can be viewed by turning the dial  .

Tab. 2

The information in the default display (→ Fig. 2 or 3) and the operation always apply only to the current heating zone.

To display the information applicable for the other heating zone:

- ▶ While in the default display, use  to switch to the other heating zone.

Contents

1	Explanation of symbols and safety information	7
1.1	Explanation of symbols	7
1.2	Safety instructions	8
2	Information about the appliance	9
2.1	Scope of delivery	9
2.2	Technical specifications	10
2.3	Cleaning	10
2.4	Supplementary accessories	11
2.5	Installation example	12
3	Installation (for installers only)	14
3.1	Installation	14
3.1.1	Installation in boiler	14
3.1.2	Wall mounting	15
3.1.3	Mounting of the outdoor temperature sensor	17
3.1.4	Mounting other accessories	18
3.1.5	Disposal	18
3.2	Making the electrical connections ..	19
3.2.1	Electrical connection in boiler	19
3.2.2	Electrical connection to wall	19
4	Commissioning (installers only)	20
5	Operation	21
5.1	Heating and DHW programs	22
5.1.1	General information	22
5.1.2	Weekly programs	22
5.1.3	Structure of programs	22
5.2	Setting programs	23
5.2.1	Viewing on the display and navigating through the menu	23
5.2.2	Setting and changing switch points and operating modes	24
5.3	Manual setting of operating modes ..	27
5.3.1	Selecting the operating mode for heating	27
5.3.2	Changing heating mode before the programmed time (bringing forward the next switch point)	28
5.3.3	Changing the domestic hot water operating mode (time-limited)	28
5.3.4	Vacation mode	28
5.4	Changing the specified room temperature	30
5.4.1	Permanently changing the specified room temperature	30
5.4.2	Changing the specified room temperature for a limited period ..	30
6	MAIN MENU settings	31
6.1	MAIN MENU summary and settings ..	31
6.1.1	MAIN MENU: Vacation	32
6.1.2	MAIN MENU: Heating	33
6.1.3	MAIN MENU: Domestic hot water ..	35
6.1.4	MAIN MENU: General settings	37
6.1.5	MAIN MENU: Solar	38
6.2	Heating program	39
6.2.1	Timer programs for heating	39
6.2.2	Temperature levels for operating modes and heating rate	41
6.3	DHW program	42
6.3.1	DHW program operating modes ..	43
6.3.2	Timer program for domestic hot water with combi boiler	44
6.3.3	Time/temperature level program for domestic hot water via tank ..	45
6.3.4	Timer program for DHW recirculation pump (systems with domestic hot water tank only)	46
6.3.5	Parameters for domestic hot water ..	47
6.3.6	Thermal disinfection of domestic hot water	48
6.4	General settings	49
6.4.1	Time, Date	49
6.4.2	Display formats	49
6.4.3	Key lock	49
6.4.4	Language	49
6.5	Solar settings	50
7	Viewing information	52

8 Menu settings INSTALLER SETTINGS (for installers only) 57

- 8.1 INSTALLER SETTINGS
menu summary and settings 57
- 8.1.1 INSTALLER SETTINGS:
System configuration 58
- 8.1.2 INSTALLER SETTINGS:
Heating parameters 59
- 8.1.3 INSTALLER SETTINGS:
Solar system config 60
- 8.1.4 INSTALLER SETTINGS:
Solar sys parameters 61
- 8.1.5 INSTALLER SETTINGS:
Fault history 63
- 8.1.6 INSTALLER SETTINGS:
Cust service address 63
- 8.1.7 INSTALLER SETTINGS:
System info 64
- 8.1.8 INSTALLER SETTINGS: Slab drying 65
- 8.1.9 INSTALLER SETTINGS: Output test 65
- 8.2 Configuring the heating system . . . 66
- 8.3 Parameters for heating 67
- 8.3.1 Parameters for the entire
heating system 67
- 8.3.2 Heating circuit parameters 68
- 8.4 Configuring the solar
thermal system 72
- 8.5 Parameters for solar
thermal system 73
- 8.5.1 Commissioning the solar
thermal system 73
- 8.5.2 Resetting parameters for
solar thermal system 73
- 8.5.3 Parameters for the standard solar
thermal system 73
- 8.5.4 Parameters for solar heating boost
system 74
- 8.5.5 Parameters for the second collector
field 75
- 8.5.6 Parameters for the solar recharge
system 76
- 8.5.7 Parameters for a high/low priority
system 76
- 8.5.8 Parameters for an external heat
exchanger 78
- 8.5.9 Parameters for thermal
disinfection 79
- 8.5.10 Parameters for solar optimization . 80
- 8.6 Fault history 82

- 8.7 Viewing and entering the customer
service address 82
- 8.8 Viewing system information 83
- 8.9 Slab drying function 83
- 8.10 Test of the actuators on the
system 85

9 Troubleshooting 86

- 9.1 Troubleshooting with display 86
- 9.2 Troubleshooting without using
display 94

10 Energy saving tips 96

11 Environmental protection 97

12 Commissioning log for the heating system 98

13 Individual timer program settings 99

- 13.1 Heating program for the heating
circuit 1 and heating circuit 2 99
- 13.2 DHW program 105
- 13.3 DHW circulation program 106

Index 107

Information regarding the documentation

Guide to instructions



Deliver all documentation enclosed to the user.

If you ...

- ... are looking for the safety instructions and an explanation of the symbols, refer to **Section 1**.
- ... are looking for a summary of the design and function of this accessory, refer to **Section 2**. There you will also find the technical data.
- ... are an INSTALLER and want to know how to install, wire up and commission this accessory, then go to **Sections 3 and 4**.
- ... want to know how to operate and program this accessory, refer to **Sections 5, 6 and 13**. There you will also find summaries of the default settings and setting ranges for the menus. There are also tables for writing down your settings.
- ... want to view information about the heating system, refer to **Section 7**.
- ... are an INSTALLER and want to make installer settings or view system information, refer to **Section 8**. There you will also find summaries of the default settings and setting ranges for the menus. There are also tables for making a note of your settings.
- ... are looking for troubleshooting tables, refer to **Section 9**.
- ... are seeking tips about energy efficiency, refer to **Section 10**.
- ... are looking for a particular reference in the document, have a look in the **Index** at the end of this booklet.

1 Explanation of symbols and safety information

1.1 Explanation of symbols

Warnings

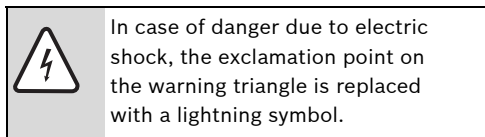
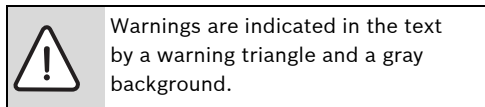

Signal words at the beginning of a warning are used to indicate the type and seriousness of the ensuing risk if measures for minimizing damage are not taken.

- **NOTE** indicates that minor damage to property may occur.
- **CAUTION** indicates possible minor to medium personal injury.
- **WARNING** indicates possible severe personal injury.
- **DANGER** indicates that severe personal injury may occur.

Important information

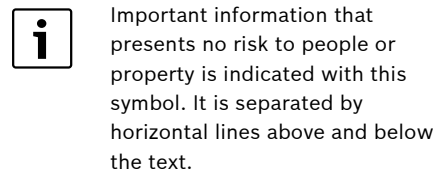









Additional symbols

Symbol	Meaning
▶	Sequence of steps
→	Cross-reference to other points in this document or to other documents
•	Listing/list entry
–	Listing/list entry (2nd level)

Tab. 3

Conventions used in these instructions for representing the menu structure:

- Individual menu levels are separated by the ▶ symbol, e.g. **Vacation ▶ Start**
- Parameters that can be set/selected on a menu are marked with a bullet point • .
- The operation of a control is indicated by the symbol for the control:
 -  means turn dial
 -  means press dial
 -  means press and release Menu button
 -  means press and release Info button
 -  means press and release Delete/Reset button
 -  means press and release Menu Up button
 -  means press and release Advance button
 -  means press and release DHW single charge button



1.2 Safety instructions

- ▶ To ensure proper function, follow these instructions.
- ▶ Install and start up the boiler and all accessories according to the associated instructions.
- ▶ Only have this accessory installed by a trained and certified installer.
- ▶ Use this accessory exclusively in conjunction with the controllers and heating appliances listed. Follow the connection diagram!
- ▶ Never connect this accessory to 120 VAC line voltage.
- ▶ Prior to mounting this accessory:
Isolate the boiler from the power supply (120 VAC) using the emergency shut-off switch or the heating system circuit breaker.
- ▶ Electrical components must be installed by a trained electrician and the installation must meet the National Electric Code as well as all applicable local codes and regulations.
- ▶ Provide a dedicated circuit breaker for the boiler and heating system rated at least 15 A.
- ▶ All line voltage wiring must use at least AWG14 size cables.
- ▶ In case of wall mounting: never mount this accessory in wet areas.
- ▶ Instruct customers about the functions and operation of this accessory.
- ▶ Risk of scalding during thermal disinfection:
Due to DHW temperatures occurring in excess of 140 °F (60 °C), Bosch strongly advises to install a DHW thermostatic mixing valve.
- ▶ When there is a risk of frost, leave the boiler switched on and follow the frost protection information.

2 Information about the appliance



The FW 200 can only be connected to a boiler with BUS-enabled Heatronic 3.

- These controls are used to display device and system information and to change the settings shown.
- In connection with the IPM 2 module the controls are an outdoor reset control for two heating zones and DHW provision with time programs:
 - Central heating : Six weekly heating programs with six switch points per day are programmable (one program is active).
 - Hot water : weekly DHW program with six switch points per day.
- Options:
 - Remote control FB 100 with IPM2 module for expansion up to max. 4 heating zones.
 - Module ISM 2 for solar water heating and solar heating boost.
- The controls have a power reserve sufficient for at least 6 hours of operation. If the controls are without power for a period longer than the power reserve, then the time and date will be deleted. All other settings are kept.
- Installation options:
 - In the boiler with BUS-enabled Heatronic 3
 - Wall-mounted with BUS link to boiler with BUS-enabled Heatronic 3

2.1 Scope of delivery

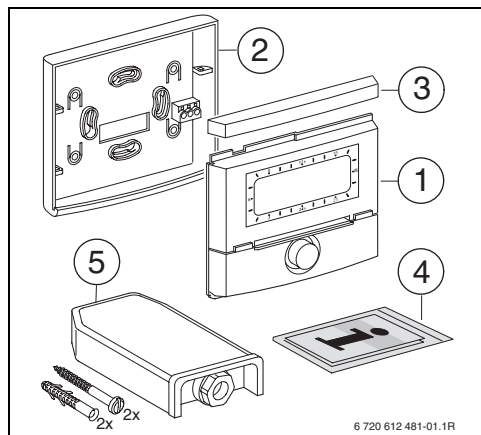



Fig. 4 Scope of delivery

- 1** Controls top section
- 2** Base for wall-mounting
- 3** Slide cover
- 4** Installation and operating instructions
- 5** Outdoor temperature sensor with mounting kit

2.2 Technical specifications

Dimensions	Fig. 10, page 15
Rated voltage	10...24 VDC
Current draw (excluding backlight)	6 mA
Controller output	2-wire BUS
Permissible ambient temperature	32 ... +122 °F (0 ... +50 °C)
Protection class	III
Protection level:	
- installed in Heatronic 3	IPX2D
- wall-mounted	IP20
	

Tab. 4 Specifications

°F	°C	Ω_{AF}	°F	°C	Ω_{AF}
- 4	- 20	2392	39	4	984
3	- 16	2088	46	8	842
10	- 12	1811	54	12	720
18	- 8	1562	61	16	616
25	- 4	1342	68	20	528
32	± 0	1149	75	24	454

Tab. 5 Measurement values outdoor temperature sensor

2.3 Cleaning

- ▶ If necessary, use a damp cloth to wipe the controls housing. Never use aggressive or acidic cleaning agents.

2.4 Supplementary accessories

See also the price list.

- **IPM 2:** module for control of up to two mixed heating zones. Control of one unmixed heating zone in the heating system possible.
- **ISM 2:** module for controlling solar water heating and solar heating boost.
- **FB 100:** Remote control with plain text display for the control of one mixed or non-mixed heating zone.

2.5 Installation example

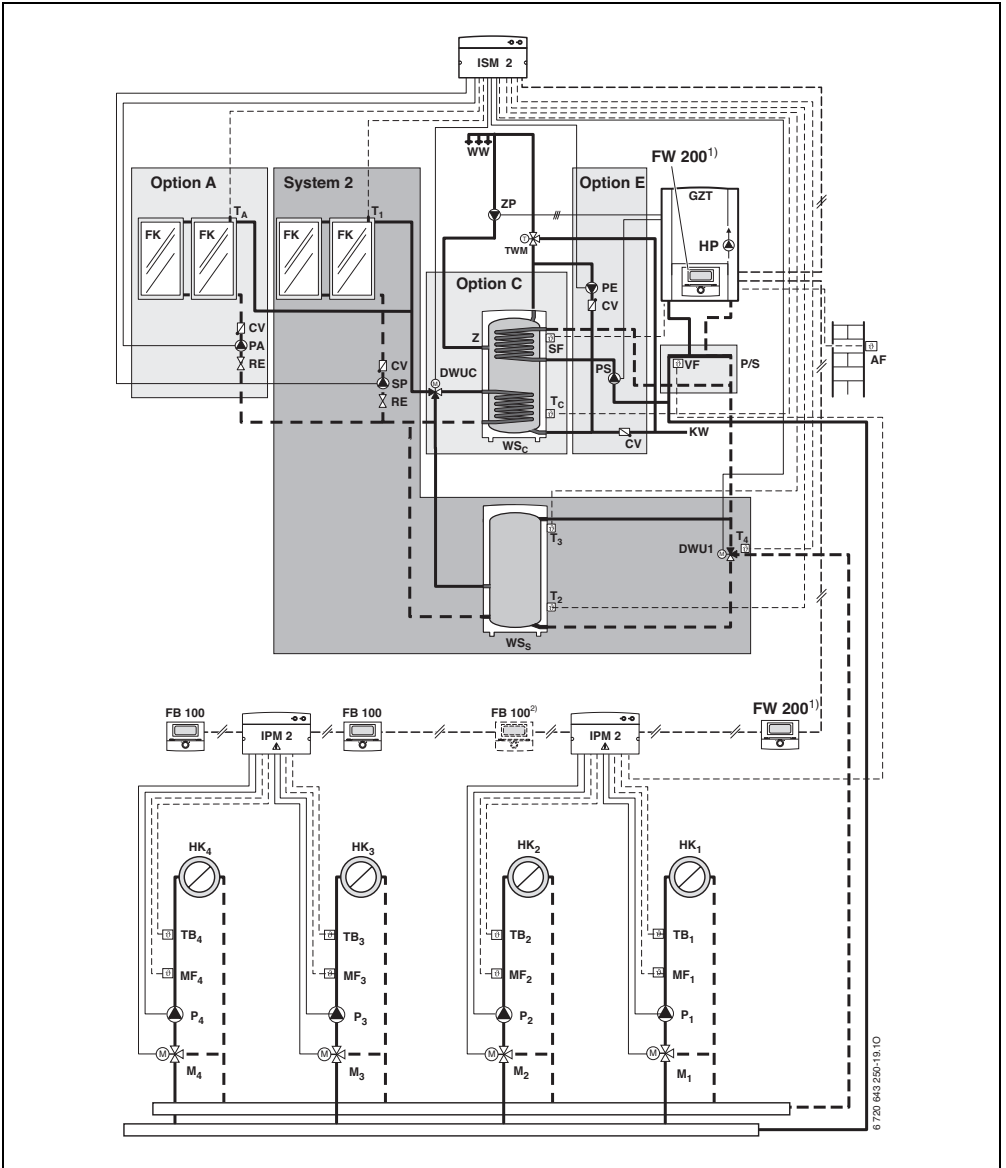

Fig. 5 Schematic diagram of system (diagram for installation purposes included in the planning documents)

AF	Outdoor temperature sensor	T₁	Collector temperature sensor for 1st collector field
CV	Flow check valve	T₂	Buffer storage tank temperature sensor, bottom
DWU1	Valve for return flow boost on the heating network	T₃	Buffer storage tank temperature sensor, top
DWUC	Valve for high/low priority storage systems (option C)	T₄	Temperature sensor heating network return for solar heating boost
FB 100	Remote control	T_A	Collector temperature sensor (option A) for 2nd collector field
FK	Solar collector	T_C	DHW-side storage tank temperature sensor, bottom
FW 200	Outdoor reset controls with solar controls	TB_{1...4}	Temperature limiter
GZT	Boiler	TWM	Thermostatic DHW mixer
HK_{1...4}	Heating zones	VF	System supply temperature sensor
HP	Boiler circulator	WS_C	DHW storage tank (option C)
IPM 2	Module for two heating zones	WS_S	Solar storage tank
ISM 2	Solar module for solar water heating and heating boost	WW	DHW connection
KW	Cold water connection	Z	Recirculation connection
M_{1...4}	Mixing valve motor	ZP	DHW recirculation pump
MF_{1...4}	Supply temperature sensor for mixed heating zone	1)	The FW 200 can optionally be installed in the boiler or mounted on the wall. If the FW 200 is installed in the boiler, a FB 100 in the first heating zone is possible.
Option A	2nd collector field	2)	Optional
Option C	High/low priority system		
Option E	Thermal disinfection of the solar tank		
P_{1...4}	Heating zone pump		
PA	Solar circuit pump (option A)		
PE	Circulation pump for thermal disinfection		
P/S	P/S Piping (Low-loss header)		
RE	Flow rate adjuster with indicator		
SF	Storage tank temperature sensor (NTC)		
SP	Solar circuit pump 1st collector field		
System 2	Heating boost and solar DHW heating		

3 Installation (for installers only)

The detailed system diagram for mounting the hydraulic components and the associated control devices can be found in the planning documents or specifications.



DANGER: Risk of electric shock!

- ▶ Prior to mounting this accessory: Isolate the boiler from the power supply (120 VAC) using the emergency shut-off switch or the heating system circuit breaker.

3.1 Installation

3.1.1 Installation in boiler

- ▶ Detailed description of boiler components, see boiler installation instructions.
- ▶ Remove the cover.

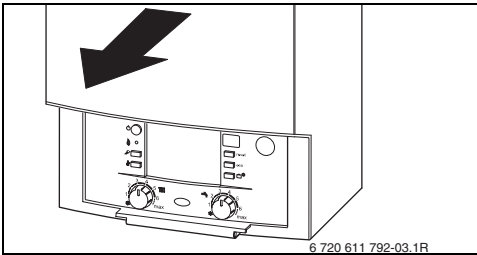

Fig. 6

- ▶ Remove cover plate and dummy cover.

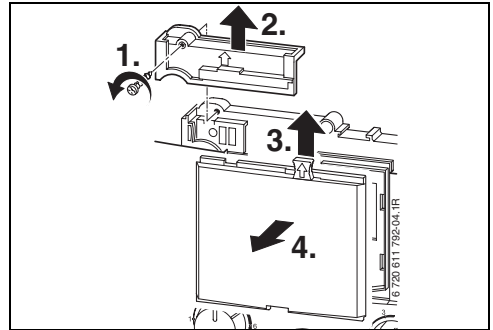

Fig. 7

- ▶ Insert top section in slots.

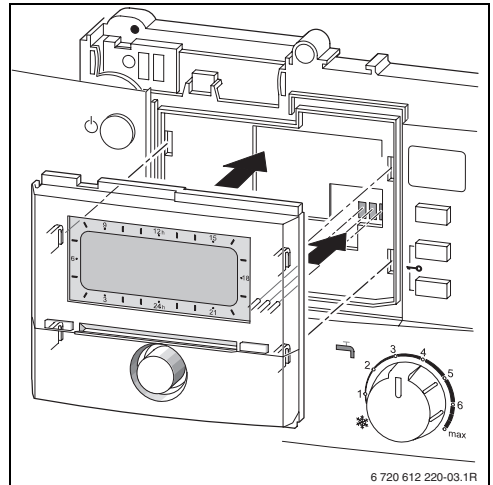

Fig. 8

- ▶ Click top section into place and mount cover plate.

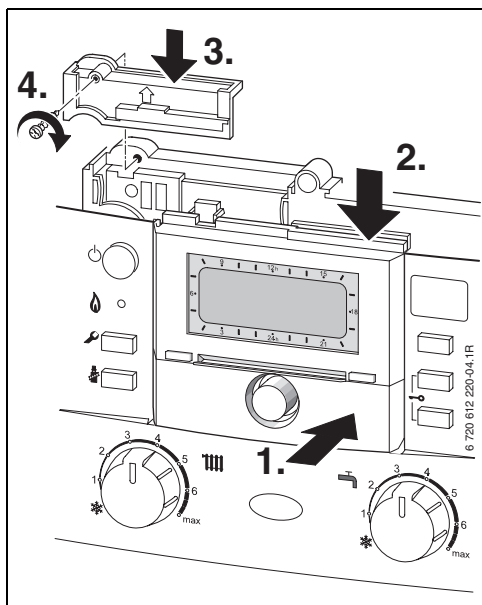

Fig. 9

3.1.2 Wall mounting

The performance of the controls depends on where they are installed.

The installation site (primary room) must be suitable for controlling the heating zones assigned.

- ▶ Select the installation location.

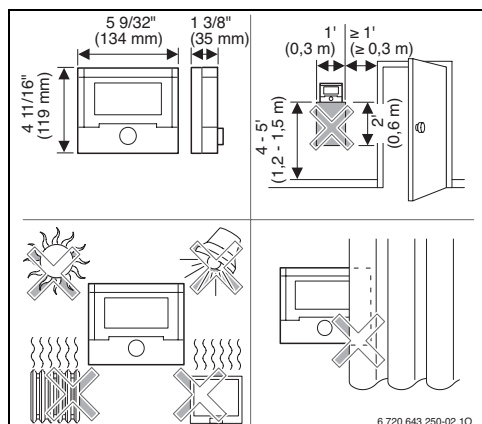

Fig. 10



The mounting surface on the wall should be level.

- ▶ Remove the top section and slide cover from the base.

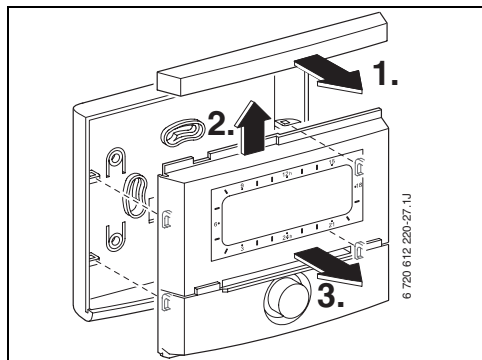

Fig. 11

- ▶ Mount the base.

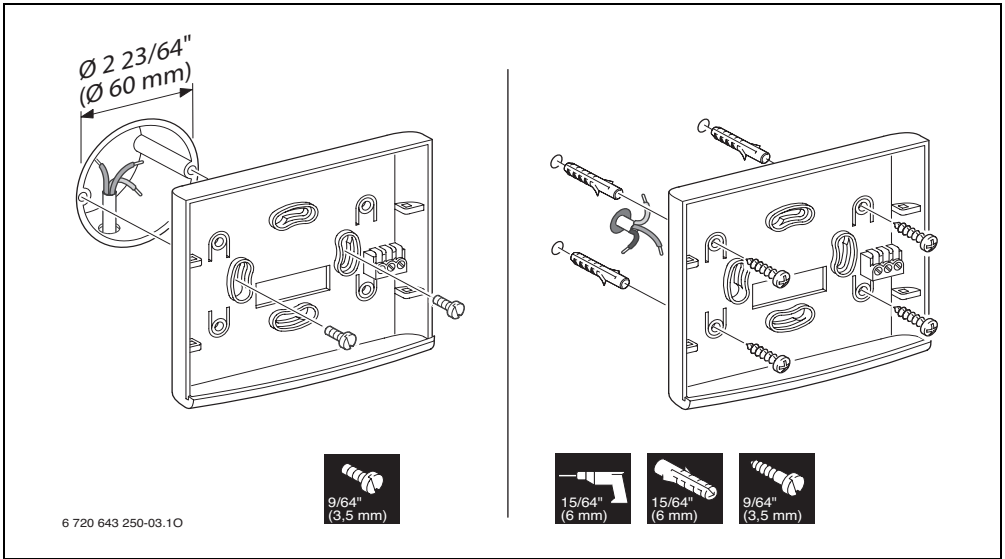

Fig. 12

- ▶ Make the electrical connections (→ Fig. 16 or 17 on page 19).
- ▶ Refit top section and slide cover on base.

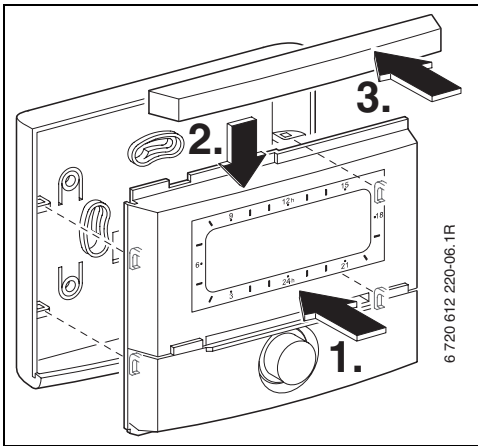

Fig. 13

3.1.3 Mounting of the outdoor temperature sensor

Performance depends on installation location of outdoor temperature sensor AF. ▶ Select the installation location.

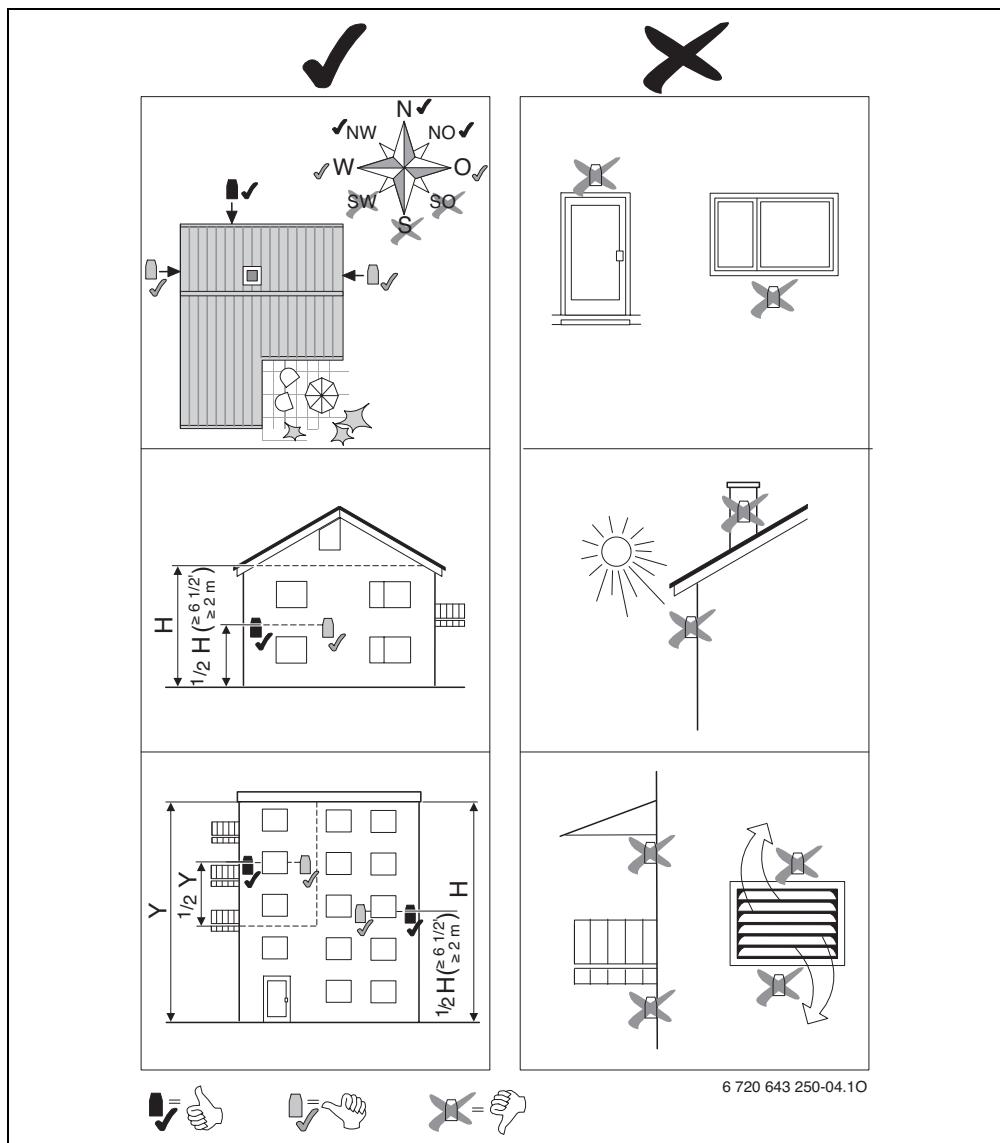

Fig. 14

- ▶ Remove cover.
- ▶ Attach sensor housing to external wall with two screws.

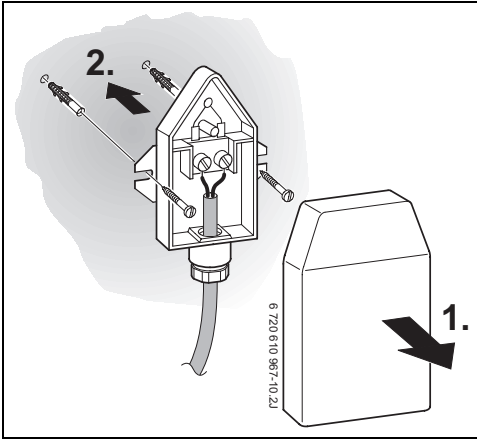

Fig. 15

3.1.4 Mounting other accessories

- ▶ Mount accessories according to code requirements and the installation instructions supplied.

3.1.5 Disposal

- ▶ Dispose of packaging in an environmentally responsible manner.
- ▶ When replacing components, dispose of the defunct parts in an environmentally responsible manner.

3.2 Making the electrical connections

3.2.1 Electrical connection in boiler

- ▶ Installation of the controls automatically produces BUS connection via the three contacts (→ Fig. 8 on page 14).

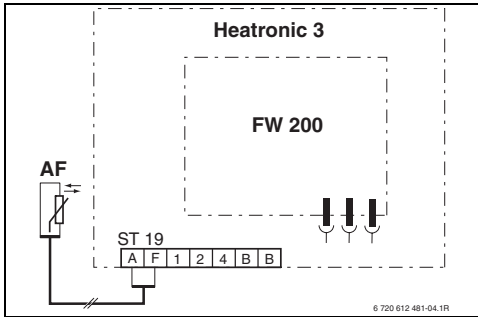

Fig. 16 Controls installed in boiler via BUS contacts in BUS-enabled Heatronic 3.



The controls recognize that the boiler is installed via the third contact.

3.2.2 Electrical connection to wall

- ▶ For BUS connection use AWG 18 (0.75 mm²) cable and do not exceed 492 ft. (150 m) total length.
- ▶ For the outdoor sensor AF use AWG 18 (0.75 mm²) cable and do not exceed 66 ft (20 m) total length.
- ▶ Route all low-voltage cables separately from cables carrying line voltage to avoid inductive interference (minimum separation 4" (100 mm)).
- ▶ In case of inductive external influences, use shielded cables. This way, the cables are shielded against external influences (e.g. high-voltage cables, contact wires, transformer stations, radio and

TV devices, amateur radio stations, microwave devices, etc.).

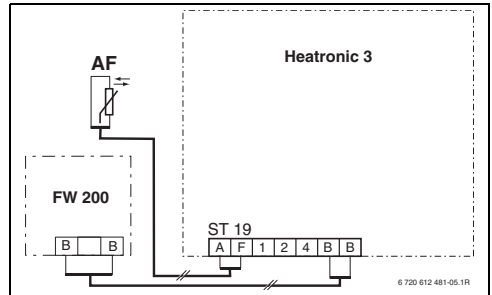

Fig. 17 Controls connected to BUS-enabled Heatronic 3.



If the BUS cables feature different cross-sections:

- ▶ Connect BUS link via a junction box.

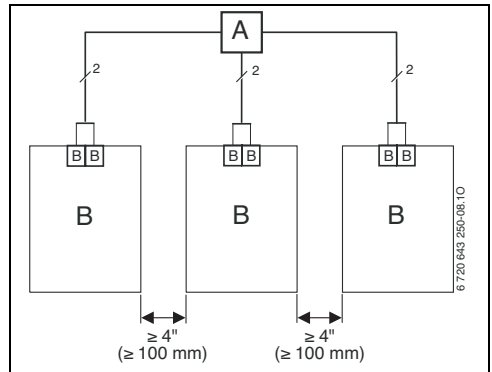

Fig. 18 Connection of BUS links via junction box

- A** Junction box
- B** BUS devices













4 Commissioning (installers only)

For correct commissioning, it is essential that the following steps are carried out in the order shown.

1. Set the DIP switch on IPM 2 in accordance with the details in the instructions supplied.
2. Switch on the system.
3. Set the DIP switch on FB 100 in accordance with the details in the instructions supplied.



The functions of the controls and the meanings of the symbols on the display are explained on pages 2 and 3.

4. When commissioning for the first time or after a complete reset (factory reset), you must select the display language:
 - Turn  to select the language and press  to confirm. (For how to change the language → Section 6.4.4 on page 49.)
5. If the power reserve has run out, set the date and time as follows:
 - Turn  to select the hour and press  to confirm.
 - Turn  to select the minute and press  to confirm.
 - Turn  to select the year and press  to confirm.
 - Turn  to select the month and press  to confirm.
 - Turn  to select the day and press  to confirm. (For how to change the date and time → Section 6.4.1 on page 49.)
6. When the unit is first commissioned, automatic system configuration starts immediately after entry of the date and time.
 - Wait for 60 seconds and then follow the instructions displayed.
- If automatic system configuration does not start of its own accord, start it from the menu → Section 8.2 on page 66.
7. Adjust other settings to suit the specifics of the system, → Section 6 starting on page 31 and Section 8 starting on page 57.
8. Fill and bleed the solar heating system according to its documentation and prepare it for commissioning as described in Section 8.4 on page 72.
9. Adjust other settings to suit the specifics of the solar heating system, → Section 8.5 starting on page 73.
10. Commission the solar heating system, → Section 8.5.1 on page 73.
11. Inform the home owner and operator of the system about its function and method of operation as follows:
 - Explain to the customer how the boiler and the controls work and how to operate them.
 - Inform the customer about the assigned heating zones, e.g. heating zone 1 is the radiator heating and heating zone 2 is the radiant floor heating.
 - Explain to the customer how the system works, e.g. time, operating modes for the heating zones, hot water temperature, time programs for heating zones and hot water.
 - Explain the use of the thermal disinfection function and the associated risk of scalding.
 - Hand all enclosed documents over to the user.
12. Complete the commissioning log, → Section 12 on page 98.

5 Operation

Introduction

With the FW 200 heating controls, you can automatically control the room temperature and hot water temperature with a heating and DHW program created according to your own individual requirements.

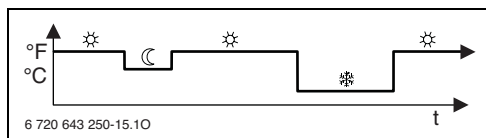

Fig. 19 Example of heating program

If the controls are set according to your individual requirements then you hardly need use the menus for “day-to-day use”. Nevertheless, it is useful to be familiar with the basic use of the menus.

Therefore, you should read the whole of Sections 5.1 and 5.2 below and adjust a heating or DHW program to your own requirements as described in Section 5.2.2.

Making the effort may be worth your while! The procedure for changing a switch point will illustrate everything you need to know about navigating through the menus and entering settings. You can then program other settings in the same way with the help of information contained in sections 6 and 8.

The description of the menus reflects the arrangement of the menu options on the heating controls. The tables in sections 6.1, 7 and 8.1 show the whole menu structure. They also provide details of the adjustment ranges and default settings for all adjustable parameters. More information on the menu options can be found in Sections 6.2 to 6.5 for user functions, and Sections 8.2 to 8.9 for installer settings.

The description of a menu options starts with its menu path. That shows you how to reach the menu option concerned through the system of menus. The individual menu levels are separated by the > symbol, e.g. vacation > start.

Some menu options are dependent on others. In such cases, a page reference directs you to a description of the menu option on which it depends. Make use of such page references to other menu options. They will help you to understand associated functions.



The controls provide the option of setting the desired room temperature for the operating mode concerned. This temperature entry is not the actual room temperature. This is an orientation value that influences the required supply temperature for the heating zone.

5.1 Heating and DHW programs

5.1.1 General information

The programs for heating and domestic hot water enable you to achieve maximum energy savings while still enjoying optimum comfort in terms of room temperature and availability of domestic hot water. That is achieved, for instance, by deactivating water heating in the periods when nobody requires domestic hot water.

5.1.2 Weekly programs

All timer programs are set up to repeat every week. In the program memory you can store 6 switch points for every day in each program, i.e. a total of up to 42 switch points.

To simplify programming, you can set switch points for groups of days as well as for individual days.

The following groups of days are offered:

- **All days**
- **Mon - Fri**
- **Sat + Sun**

If, for example, you change and store a switch point for the option **Mon - Fri**, that change is simultaneously applied to all days from **Monday** to **Friday**.

5.1.3 Structure of programs

Programs for heating and domestic hot water are always structured in the same way. Up to six switch points (times) can be specified. A change of operating mode is specified for each switch point. The specified operating mode applies until changed by the next switch point.

Heating programs

Heating programs control heating operation. There are three modes for heating operation:

- **Comfort** ☀
- **Economy** ☾
- **Frost** (Frost protection) ❄

For each of those operating modes, there is a specified room temperature stored on the FW 200 heating controls (→ Section 5.4.1, page 30).

There are a total of six program spaces (A to F) available for heating programs. Each heating program contains the switch points for one week (weekly program). You can activate one of the heating programs for each heating zone.



Having several stored heating programs simplifies changing from one heating program to another, e.g. if your job involves periods when you work different shifts (night shift/day shift), or for vacation periods.

DHW programs

DHW programs operate differently according to the type of domestic hot water system:

- With combination boilers (boilers that produce domestic hot water instantaneously on demand) the DHW program switches between the following operating modes:
 - **On:** if the Eco button on the boiler is not lit, hot water is available immediately on demand (Comfort mode).
 - **Off:** the built-in plate heat exchanger in the boiler is not kept constantly hot (Eco mode); as a result energy is saved. In Eco mode, the hot tap has to be run for a short while before the water becomes hot.

- With appliances connected to a domestic hot water tank, the DHW program specifies the desired water temperature (set temperature).
 - If the temperature measured in the domestic hot water tank is below the specified temperature, the tank is reheated.
 - Once the specified temperature is reached (or exceeded), tank heating is stopped.



If the DHW program changes from a higher to a lower specified temperature, the water in the tank will not immediately cool to the lower temperature, i.e. water at a higher temperature will continue to be available for some time. However, the tank will not be reheated until the temperature falls below the new, lower specified temperature.

Recirculation program

The recirculation program specifies when a connected secondary recirculation pump for domestic hot water runs.

5.2 Setting programs

















The functions of the controls and the meanings of the symbols on the display are explained on pages 2 and 3.

5.2.1 Viewing on the display and navigating through the menu

The user interface of the outdoor reset controls FW 200 is implemented as a menu system. Within that menu system, the various functions are arranged in a hierarchical structure. For greater clarity, the menu system is subdivided into three sections (**MAIN MENU**, **INFO**, and **INSTALLER**

SETTINGS). Each section can be accessed by its own button. The entire menu structure is shown in tabular form in Sections 6.1, 7 and 8.1.

To navigate through the menu system:

- Pressing  opens the **MAIN MENU**. From any point within the **MAIN MENU**, pressing  takes you back to the default display.
- Pressing  opens the **INFO**. From any point within the **INFO** menu, pressing  takes you back to the default display.
- Pressing and holding  for at least 3 seconds opens the **INSTALLER SETTINGS** menu. From any point within the **INSTALLER SETTINGS** menu, pressing  takes you back to the default display.
- The menu option/parameter selected in each case is **highlighted**.
- Arrows in the left margin indicate that there is more information than can be shown on the display at once. It can be viewed by turning the dial .
- Pressing the dial  opens the submenu associated with the selected menu option/parameter or activates editing mode for the parameter (the parameter setting starts flashing).
- A flashing parameter value (e.g. switch point or operating mode)
 - can be changed by turning the dial .
 - can be reset to the factory settings by pressing .
 - is stored by pressing the dial .
 - remains unchanged if any other button apart from the dial  is pressed.
- To return to the next menu up from a submenu:
 - Select the menu option back  and confirm by pressing the dial , or
 - Press .

5.2.2 Setting and changing switch points and operating modes

The way in which switch points and operating modes are set is always the same, the only differences are due to the various operating modes for each switch point.

The unit is supplied with programs for heating and domestic hot water already stored. It may also be that your installer has adjusted the programs to suit your requirements.

Changing (moving or deleting) a single switch point



The example below shows all the steps required to change a switch point in a heating program. If, instead, you want to change a switch point in a DHW program, open the DHW program in question (menu path: **Domestic hot water > DHW program > Edit**) and change the switch point in the same way.

- ▶ Open flap.

The default display continues to be shown.

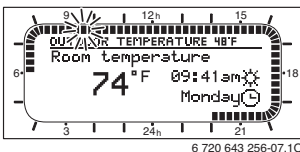

- ▶ Press .

The display lighting switches on and the main menu is displayed.

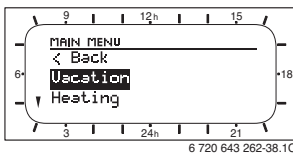

- ▶ Turn the dial until the menu option **Heating** is selected.

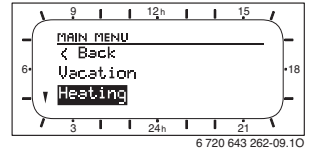

- ▶ Press .

The Heating menu is selected and the title bar shows the current menu name (in this case **HEATING**).

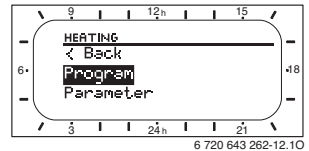

- ▶ Turn the dial until the menu option **Program** is selected.

- ▶ Press .

The Program menu is selected and the title bar shows the current menu name (in this case **HEATING PROGRAM**).

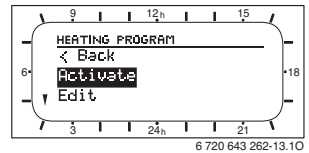

- ▶ Turn the dial until the menu option **Edit** is selected.

- ▶ Press .

The **Edit** menu is selected and the title bar shows the current menu name (in this case **EDIT HEATING PROGRAM**).

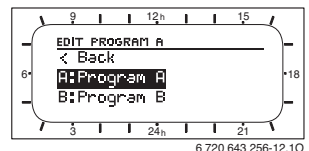

- ▶ Turn \uparrow / \downarrow until it points to the required heating program (e.g. **A:Program A**).
 - ▶ Press $\frac{\Delta}{ok}$.
- The heating program (e.g. A:Program A) is selected and the title bar shows the current menu name (**EDIT PROGRAM A**).

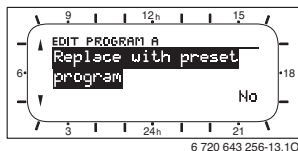

- ▶ Turn \uparrow / \downarrow until it points to the desired day (or group of days), e.g. **Monday**. The segment ring always shows you the heating program if you display precisely one day (e.g. **Monday**) or if for a group of days, the switch points for all days in this group are the same (e.g. all switch points for **Mon - Fri**).

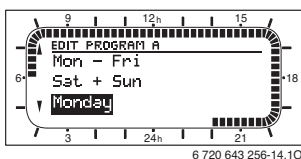

- ▶ Press the dial $\frac{\Delta}{ok}$ to confirm the menu option **Monday**. The next submenu (**EDIT PROGRAM A MON**) showing the programmed switch points and operating modes **P1** to **P6** is displayed.

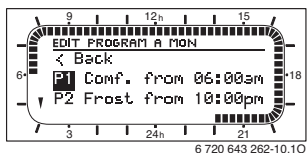

- ▶ Turn the dial \uparrow / \downarrow until the menu option **P1** (= switch point 1) is selected.

- ▶ Press $\frac{\Delta}{ok}$. The switch point and corresponding segment on the segment ring start to flash.

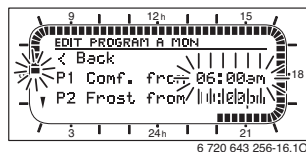

- ▶ Turn \uparrow / \downarrow until the desired switch point is displayed (e.g. **05:30am** or **05:30**). The ring of segments always shows the effect of the change on the heating program.

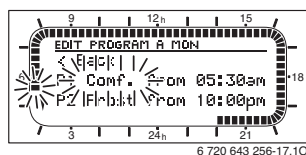

- ▶ Press $\frac{\Delta}{ok}$. The switch point is saved. The associated operating mode now starts flashing on the display.
- ▶ Turn \uparrow / \downarrow until the required operating mode (e.g. **Economy**) is displayed. The ring of segments always shows the effect of the change on the heating program.

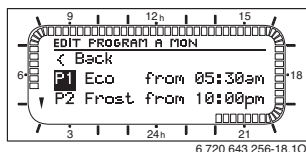

- ▶ Press $\frac{\Delta}{ok}$. The operating mode is saved. Setting of **P1** is now complete.
- ▶ You can now:
 - change more switch points and operating modes in the same way, or
 - finish programming and return to the basic display by pressing $\frac{\square}{menu}$.

Using groups of days when programming

In many cases, you may want to program the same switch points for several days of the week, say for all working days. However, you may also want a different program for just one of those days.

Using the groups of days when programming enables you to complete the process in only a few steps.

- ▶ For a group of days, e.g. **Mon - Fri**, program the switch points and operating modes that are the same for the majority of those days.
- ▶ Then change the switch points for the days that are different.

Copying ready-made programs

There are eight preprogrammed heating programs permanently stored on the heating controls. These cannot be applied directly to a heating circuit.

To be able to use the ready-made heating programs, you must copy them to one of the locations for heating programs (A to C), where you can also adapt them if necessary (→ Section 5.2.2).





Programs A to F can also be copied to another memory slot.

Select the storage location **to which the program is to be copied** (A to F):

- ▶ Open menu option **Heating > Program > Edit > A:Program A ... F:Program F**.

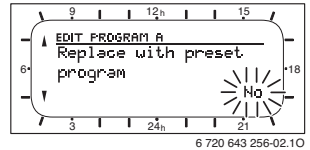
- ▶ Press the dial  twice.
The function **Replace with preset program** is selected and the option **No** is flashing.





- ▶ Turn  until the heating program to be copied is in the last line of the screen (e.g. **All day**).
 - ▶ Press .
- The heating program has now been copied.

Resetting an entire program (replacing with factory settings)

The unit is supplied with programs for heating and hot water already stored in the memory (→ Section 13 on page 99).



Overwrite one of your own heating programs, A to F, as follows:

- ▶ Bring up the relevant program (e.g. Menu: **Heating > Program > Edit > C:ProgramC** or Menu: **Domestic hot water > DHW program > Edit**).
 - ▶ Turn the dial  to select the option **Reset factory settings**.
 - ▶ Press .
- The program has now been reset to the factory settings.



Resetting all settings (for installers only)

This function resets all settings on the **MAIN MENU** and the **INSTALLER SETTINGS** to their factory settings. **Following such a reset, your installer will need to commission the system again!**

If the default display is showing:

- ▶ Simultaneously press and hold  and  until the following warning message appears:



- ▶ Continue holding  and  until the following message appears:

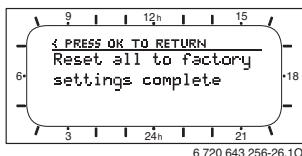

- ▶ Press . All settings have now been reset to their factory settings with the exception of the date and time, which remain unchanged.

5.3 Manual setting of operating modes

The information in the default display (→ Fig. 2 or 3 on page 2) and the operation always apply only for one heating zone.

To display the information applicable for the other heating zone:

- ▶ During the default display, use  to switch to the other heating zone.



5.3.1 Selecting the operating mode for heating



In normal operation, always leave the dial in the **auto** position. By using correctly set heating programs, you can save energy and enjoy comfort.



Automatic (factory setting)

Switches automatically between the modes **Comfort**  / **Economy**  / **Frost**  according to the active heating program.



Constant heating

The controls constantly maintain the room temperature set for **Comfort**  operating mode.



Constant economy

The controls constantly maintain the room temperature set for **Economy**  operating mode.



Constant frost protection

The controls constantly maintain the room temperature set for **Frost**  operating mode.

5.3.2 Changing heating mode before the programmed time (bringing forward the next switch point)

This function brings forward the time at which the operating mode **Comfort** ☀ / **Economy** ☾ / **Frost** ❄ set for the next switch point becomes active.



The change applies only to the day on which you activate the function.

- ▶ The function can be used in situations such as going to bed earlier, being away from home longer or coming back earlier.
- ▶ If you are going to be away from home for several days, e.g. on vacation, you should use the Vacation function, → Section 5.3.4, page 28.

This function is only available if the heating circuit is not regulated via remote control FB 100 and the automatic operation **auto** is switched on.

- ▶ Press and release to bring forward the next switch point and the associated operating mode **Comfort** ☀ / **Economy** ☾ / **Frost** ❄ for the selected heating circuit to the current time.

The segments around the perimeter of the display show the changed settings.

-or-

- ▶ Press and hold and simultaneously turn the dial to change the next switch point.

The segments around the perimeter of the display show the changed settings.

To undo the change to the switch point:

- ▶ Press again briefly.

5.3.3 Changing the domestic hot water operating mode (time-limited)



You can use this function if you need hot water outside the programmed times.

- ▶ Press and release to activate hot water mode immediately.
 - The hot water tank is heated up to the temperature set in the DHW program for 60 minutes.
 - With a combi boiler, Comfort mode is activated for 30 minutes.

To undo the change to the domestic hot water mode:

- ▶ Press again briefly.

5.3.4 Vacation mode

You can use this function if you want to set a constant operating mode for several days (e.g. **Frost** ❄) without changing the heating program.

When the vacation program is active, the heating circuits and domestic hot water systems are operated according to the operating mode set in the vacation program (frost protection is automatically provided).



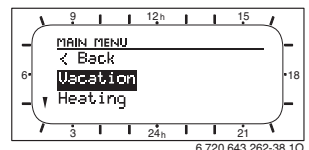

- ▶ Press .

The display lighting switches on and the main menu is displayed.



- ▶ Press .



The Vacation menu is selected and the title bar shows the current menu name (in this case **Vacation**).

- ▶ Press the dial , the display changes to the Vacation menu and **Start** is selected. Now you can enter the date on which you want the vacation program to start. Enter the year, month and day one after the other and confirm your entry in each case by pressing the dial .
- ▶ Turn the dial  so that **End** is selected.
- ▶ Press . Now you can enter the date on which you want the vacation program to end. Enter the year, month and day one after the other and confirm your entry in each case by pressing the dial .





If you have set the vacation program to start on today's date, it will start immediately. If the date is in the future, the vacation program will start at 12:00am (00:00) on the set start date.
It will end at 11:59pm (23:59) hours on the set end date.

Programming of the vacation program is now complete. If required, you can adjust the heating and domestic hot water modes. The following operating modes are set in the factory settings:

- **Heating circuit 1:** Operating mode **Frost** .
- **Heating circuit 2:** Operating mode **Frost** .
- **Domestic hot water:** Operating mode **Off**¹⁾ or **60 °F (15 °C)**²⁾.
- **DHW recirculation pump:** **Off** mode.
- **Thermal disinfection:** **Off** mode.

When the vacation program is active, the standard display shows  and the dates, e.g. **VACATION UNTIL 09/30/2010** (30.09.2010).

To cancel the vacation program early:

- ▶ Select menu option **Vacation > Start**.
- ▶ Press the dial  and then press . The display shows **--/--/---** (--..----).
- ▶ Press the dial  to store the setting.

1) DHW heating with combi boiler

2) DHW heating via hot water tank

5.4 Changing the specified room temperature



The controls provide the option of setting the desired room temperature for the operating mode concerned. This temperature entry is not the actual room temperature. This is an orientation value that influences the required supply temperature for the heating zone.

5.4.1 Permanently changing the specified room temperature

The following temperatures are stored as the factory settings for the specified room temperature:

- Operating mode **Comfort** ☀: 70 °F (21 °C)
- Operating mode **Economy** ☾: 60 °F (15 °C)
- Operating mode **Frost** ❄: 42 °F (5 °C)

The heating controls regulate the heating system so that actual room temperature is kept as close as possible to the specified temperature for the set operating mode (in **auto** mode as determined by the active heating program and the time of day). You can change these set values independently for each heating circuit.

If you wish to permanently alter the specified room temperature settings, proceed as follows:

- ▶ Call up menu: **Heating > Parameter > Heating circuit 1...2 > Heating levels.**
- ▶ Set values for each operating mode.

5.4.2 Changing the specified room temperature for a limited period

This function is only available if the heating circuit is not regulated via remote control FB 100.

- ▶ Set the desired room temperature using the dial .

While you are changing the set room temperature the display shows the desired room temperature or a bar ¹⁾, which shows a set change.

- If the mode selector is set to **auto**:
The new temperature applies until the next switch point.
- If the mode selector is set to ☀ / ☾ / ❄:
The new temperature applies until the mode selector position is changed.

1) The bar is shown if the heating controls FW 200 are installed in the boiler facia or room influence is not active. For setting the room influence for installers, see page 70

6 MAIN MENU settings

Moving through menu structure, programming, deleting values and reverting to the default setting are described in detail in section 5.2 from page 23.

6.1 MAIN MENU summary and settings

The tables set out below provide

- an overview of the menu structure (column 1).
The menu depth is identified by various shades of gray.
E. g. in the menu **Heating > Program** the submenus **Edit** and **View** are on the same level.
- an overview of the factory settings (column 2), e.g. for the purposes of resetting individual menu options to the factory settings.
- an overview of the adjustment ranges of the individual menu options (column 3).
- space for making a note of your personal settings (column 4).
- references to the detailed descriptions of the individual menu options (column 5).



The menu options are only shown if the system components are present and/or active and if no remote control is accessing these. Some menu options are not shown because they are switched off by a setting for another menu option.

- ▶ Always set or skip menu options in order. In that way, subsequent menu options will be automatically adjusted or not shown.
-

6.1.1 MAIN MENU: Vacation

Menu structure			Personal setting	Description starts on page
Vacation	Default setting	Control range		
Start	- - - - -	Today ... 12/31/2099 (31.12.2099) (in increments of one year/month/day)		28
End	- - - - -	Start date ... 12/31/2099 (31.12.2099) (in increments of one year/month/day)		
Heating circuit 1	Frost	Frost Economy Comfort Auto		
Heating circuit 2	Frost	Frost Economy Comfort Auto		
Domestic hot water	Off ¹⁾	Off Auto On ¹⁾		
	60 °F (15 °C) ²⁾	60 °F (15 °C) ... Maximum tank temperature Auto ²⁾		
DHW recirculation pump	Off	Off Auto On		
Thermal disinfection	Off	Off On		

1) DHW heating with combi heating system

2) DHW heating via indirect fired DHW tank

6.1.2 MAIN MENU: Heating

Menu structure Heating	Default setting	Control range	Personal setting	Description starts on page
Program	-	-	-	-
Activate	-	-	-	-
Heating circuit 1	A:Program A (switch points from Family program)	A:Program A ... F:Program F (Program name can be changed)		
Heating circuit 2	D:Program D (switch points from Family program)	A:Program A ... F:Program F (Program name can be changed)		
Edit	-	-	-	-
A: Program A ... F: Program F	-	-	-	-
Replace with preset program	No	No A:Program A ... F:Program F (Program name can be changed) AM weekday worker PM weekday worker All day All day, lunch Family All day, early shift All day, late shift Seniors		-
All days	→ table starting on page 99	→ table starting on page 101	→ table starting on page 103	
P1, P2 ... P6				
Mon - Fri				
P1, P2 ... P6				
Sat + Sun				
P1, P2 ... P6				
Monday, Tuesday ... Sunday				
Reset factory settings	No	No Yes		
Program name	As selected on Edit menu, e.g. Program A	Edit program name		
View	-	-	-	-
A: Program A ... F: Program F AM weekday worker PM weekday worker All day All day, lunch Family All day, early shift All day, late shift Seniors	All days	All days Mon - Fri Sat + Sun Monday, Tuesday ... Sunday		-

Menu structure Heating	Default setting	Control range	Personal setting	Description starts on page
Parameter	–	–	–	
Heating circuit 1	–	–	–	
Heating levels	–	–	–	
Comfort	70 °F (21.0 °C)	32 °F ... 86 °F (0 °C ... 30 °C) (not lower than Economy)	°F (°C)	41
Economy	59 °F (15.0 °C)	32 °F ... 86 °F (0 °C ... 30 °C) (not lower than Frost and not higher than Comfort)	°F (°C)	
Frost	41 °F (5.0 °C)	32 °F ... 86 °F (0 °C ... 30 °C) (not higher than Economy)	°F (°C)	
Heat-up speed	Normal	Economy Normal Fast		
Heating circuit 2	–	–	–	
Heating levels	–	–	–	
Comfort	70 °F (21.0 °C)	32 °F ... 86 °F (0 °C ... 30 °C) (not lower than Economy)	°F (°C)	
Economy	59 °F (15.0 °C)	32 °F ... 86 °F (0 °C ... 30 °C) (not lower than Frost and not higher than Comfort)	°F (°C)	
Frost	41 °F (5.0 °C)	32 °F ... 86 °F (0 °C ... 30 °C) (not higher than Economy)	°F (°C)	
Heat-up speed	Normal	Economy Normal Fast		

6.1.3 MAIN MENU: Domestic hot water

Menu structure	Default setting	Control range	Personal setting	Description starts on page
Domestic hot water				
DHW and DHW recirculation pump	Separate programs	Separate programs As heating program		
DHW program ¹⁾	–	–	–	
Edit	–	–	–	
All days	→ table starting on page 105	→ table starting on page 105	→ table starting on page 105	42
P1, P2 ... P6				
Mon - Fri				
P1, P2 ... P6				
Sat + Sun				
P1, P2 ... P6				
Monday, Tuesday ... Sunday				
P1, P2 ... P6				
Reset factory settings	No	No Yes		
View	–	–	–	
All days Mon - Fri Sat + Sun Monday, Tuesday... Sunday	–	–	–	
DHW recirc pump prog ¹⁾	–	–	–	
Edit	–	–	–	
All days	→ table starting on page 106	→ table starting on page 106	→ table starting on page 106	46
P1, P2 ... P6				
Mon - Fri				
P1, P2 ... P6				
Sat + Sun				
P1, P2 ... P6				
Monday, Tuesday ... Sunday				
P1, P2 ... P6				
Reset factory settings	No	No Yes		
View	–	–	–	
All days Mon - Fri Sat + Sun Monday, Tuesday... Sunday	–	–	–	

Menu structure				Personal setting	Description starts on page
Domestic hot water		Default setting	Control range		
Parameter		–	–	–	
	Tank temp in Comfort Mode	140 °F (60 °C)	60 °F (15 °C) ... Maximum tank temperature	°F (°C)	47
	Tank temp in Eco Mode	122 °F (50 °C)	60 °F (15 °C) ... Maximum tank temperature	°F (°C)	
	DHW priority	Priority	Priority Conditional priority		
	DHW recirc pump cycles	4/h	1/h ... 7/h	/h	
Thermal disinfection		–	–	–	48
Operating mode		Manual	Manual Auto		
Operating status		Not running	Not running Start now		
		Running	Running Stop		
Time		01:00am (01:00 h)	12:00am ... 11:45pm (00:00 h ... 23:45 h) ²⁾	h	
Time interval		7 d	1 d ... 30 d	d	

1) Only with "Separate programs"

2) Display is dependent on set "Display format"

6.1.4 MAIN MENU: General settings

Menu structure	Default setting	Control range	Personal setting	Description starts on page
General settings				
Time and date	–	–	–	
Time	– : – : –	12:00am ... 11:59 ¹⁾ (in increments of one hour/minute)		49
Date	– – . – – . – – – –	01/01/2005 ... 12/31/2099 ¹⁾ (in increments of one day/month/year)		
Time adjustment	0.0 sec/week	– 60.0 sec/week ... +60.0 sec/week	sec/week	
Display format	–	–	–	
Time	12 am/pm	12 am/pm 24h		49
Date	MM/DD/YYYY	DD.MM.YYYY or MM/DD/YYYY		
Temperature unit	°F	°F °C ²⁾		
Display contrast	According to factory test	25% ... 75%	%	
Information at top of display	Without ISM and tank: Outdoor temperature	Outdoor temperature Date		
	Without ISM, with tank: Outdoor temperature	Outdoor temperature Date Tank Temperature		
	With ISM and tank: Solar pump status	Solar pump status Solar yield Outdoor temperature Date Tank Temperature		
	With ISM without tank: Solar pump status	Solar pump status Solar yield Outdoor temperature Date		
Key lock	Off	Off On		49
Language	American	American Français Español Deutsch		49

1) Display is dependent on set “Display format”

2) With the setting of the unit for the temperature, other units are also switched (only for solar systems: sq.ft. → m², BTU → Wh, MBTU → kWh)

6.1.5 MAIN MENU: Solar

Menu structure Solar	Default setting	Control range	Personal setting	Description starts on page
T2: Max. solar tank temperature	140 °F (60 °C)	Disabled (<60 °F or <15 °C) 60 °F (15 °C) ...194 °F (90 °C)	°F (°C)	50
TB: Max. temperature tank B	140 °F (60 °C)	Disabled (<60 °F or <15 °C) 60 °F (15 °C) ...194 °F (90 °C)	°F (°C)	
TC: Max. temperature tank C	140 °F (60 °C)	Disabled (<60 °F or <15 °C) 60 °F (15 °C) ...194 °F (90 °C)	°F (°C)	
DHW optimization	0 °F (0 °C)	0 °F (0 °C) (= function off) ... 36 °F (20 °C)	°F (°C)	
Heating circuit 1 optimization	0 °F (0 °C)	0 °F (0 °C) (= function off) ... 9 °F (5 °C)	°F (°C)	
Heating circuit 2 optimization	0 °F (0 °C)	0 °F (0 °C) (= function off) ... 9 °F (5 °C)	°F (°C)	

6.2 Heating program

Main menu: Heating



Set the supply temperature control on the boiler to the maximum required supply temperature.

6.2.1 Timer programs for heating

Heating programs control heating operation. There are three modes for heating operation:

- **Comfort** ☀
- **Economy** ☾
- **Frost** ❄

For each of those operating modes, there is a specified room temperature stored on the FW 200 heating controls (→ Section 6.2.2, page 41).

There are a total of six program spaces (A to F) available for heating programs. Each heating program contains the switch points for one week (weekly program). You can activate one of the heating programs for each heating zone.



Having several stored heating programs simplifies changing from one heating program to another, e.g. if your job involves periods when you work different shifts (night shift/day shift), or for vacation periods.

Menu: Heating > Program

Use this menu to produce, amend or activate a heating program for each heating circuit. The heating programs are only active if the mode selector is set to **auto**.

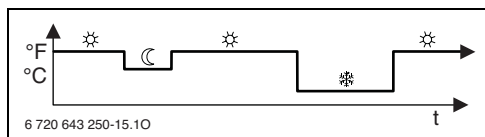

Fig. 20 Example of heating program

For menu structure and adjustment ranges → page 33.

Menu: Heating > Program > Activate

Use this menu to assign heating circuit 1 and heating circuit 2 different heating programs.

- **Heating circuit 1:** Select and activate heating program for heating circuit 1.
- **Heating circuit 2:** Select and activate heating program for heating circuit 2.

For menu structure and adjustment ranges → page 33.



Menu: Heating > Program > Edit

Use this menu if you want to adjust a heating program with personalized time/temperature level profile to each heating circuit.

For menu structure and adjustment ranges → page 33.

Menu: Heating > Program > Edit > A:Program A ... F:Program F

Use this menu to adapt the heating program of your choice.

- **Replace with preset program:** Overwrites the selected heating program with an existing heating program of your choice.
 - **A:Program A ...F:Program F:** Heating programs with personalized time/temperature level profiles (program names can be changed, see below).
 - **AM weekday worker ... Seniors:** Predefined heating programs.
- **Reset factory settings:** Resets heating program to factory settings → page 26.
- **Program name:** Changes name of heating program using  and . The 18 characters displayed can be individually replaced by selecting the letters and numbers offered.







To enter spaces:

- ▶ When the selected character is shown with a dark background, delete by pressing  (space = _)

For menu structure and adjustment ranges → page 33.

Menu: Heating > Program > Edit > A:Program A ... F:Program F > All days

Use this menu to set identical times for every day for the heating program of your choice.

- **P1, P2 ... P6:** Maximum of six switch points per day and three different operating modes (**Comfort**  / **Economy**  / **Frost** ).
 - The shortest switching interval is 15 minutes (= 1 segment).
 - Deactivate switch points that are not required by deleting them.
 - Skip switch points and operating modes that are not to be changed by pressing  or turning  the dial.

For menu structure and adjustment ranges → page 33.

Menu: Heating > Program > Edit > A:Program A ... F:Program F > Mon - Fri

Use this menu to set identical times for the days Monday to Friday for the heating program of your choice.

- **P1, P2 ... P6:**
For explanation see **All days** above.

Menu: Heating > Program > Edit > A:Program A ... F:Program F > Sat + Sun

Use this menu to set identical times for Saturday and Sunday for the DHW program of your choice.

- **P1, P2 ... P6:**
For explanation see **All days** above.

For menu structure and adjustment ranges → page 33.

Menu: Heating > Program > Edit > A:Program A ... F:Program F > Monday, Tuesday... Sunday

Use this menu to set different times for individual days in the heating program of your choice (e.g. **Thursday**: start the selected operating mode each Thursday at the same time).

- **P1, P2 ... P6:**
For explanation see **All days** above.



If, for example, the programming for **Thursday** differs from the other weekdays, the options **All days** and **Mon - Fri** show ----- from ---:-- for all settings. I.e. there are no common switch points and operating modes for this selection.

For menu structure and adjustment ranges → page 33.

Menu: Heating > Program > View

- Shows switch points and associated operating modes for **All days, Mon - Fri, Sat + Sun** or the individual day of the week as a segment pattern.

For menu structure and adjustment ranges
→ page 33.

6.2.2 Temperature levels for operating modes and heating rate**Menu: Heating > Parameter**

Use this menu to permanently set the temperature levels for the 3 operating modes (**Comfort** ☀ / **Economy** ☾ / **Frost** ❄) and the heating rate to suit your personal preferences and your home.

Menu: Heating > Parameter > Heating circuit

Use this menu to select the heating circuit for which you would like to set each of the operating modes:

- **Heat-up speed:** Use this menu option to set the required heating rate for the **Heating circuit 1** and/or **Heating circuit 2:**
 - **Economy** = The building is heated up slowly, thus saving energy.
 - **Normal** = The building is heated up at the “normal” rate.
 - **Fast** = The building is heated up quickly, thus providing maximum comfort.

For menu structure and adjustment ranges
→ page 34.

Menu: Heating > Parameter > Heating circuit > Heating levels

Use this menu to set the desired room temperature for each of the operating modes of the **Heating circuit 1** and/or **Heating circuit 2:**

- **Comfort** ☀ = maximum required temperature (e.g. when the living space is occupied and occupants require a comfortable room temperature).
- **Economy** ☾ = medium required temperature (e.g. when a lower temperature is sufficient or when the home is empty or everyone is in bed and you do not want the house to cool down too much).
- **Frost** ❄ = minimum required temperature (e.g. when the home is empty or everyone is in bed and it is OK for the house to cool down). Consider any pets and plants.

For menu structure and adjustment ranges
→ page 34.

6.3 DHW program

Main menu: Domestic hot water



Set the hot water temperature control on the boiler to the maximum required domestic hot water temperature.

If a DHW tank is connected to the IPM after the low-loss header, set the supply temperature controller on the boiler to the right stop.

• DHW and DHW recirculation pump

You can use this menu option either to ...
... Activate your individual DHW program (**Separate programs**). Recommended for systems with remote control FB100.

- or -

... connect the DHW program with your heating program (**As heating program**). That is useful if you frequently switch between different heating programs. The DHW program is then automatically adapted to suit. Recommended for systems without remote control FB100.

- **As heating program** (Automatic mode together with heating program):

With combi boiler:

Hot water **On** as long as the heating system is in **Comfort** ☀ operating mode and for 1 hour afterwards (overrun time).

Otherwise hot water **Off**.

With hot water tank:

1 hour before the first heating circuit switches to **Comfort** ☀ mode, the tank starts heating up to the set hot water temperature (**Tank temp in Comfort Mode**¹⁾). This setting remains active as long as the heating system is in mode **Comfort** ☀.

If one of the two heating circuits is in mode **Economy** ☾ (and the other is in mode **Economy** ☾ or **Frost** ❄), the tank is kept at the temperature set for **Tank temp in Eco Mode**¹⁾.

If both heating circuits are in **Frost** ❄ mode then frost protection is also active for the tank (60 °F (15 °C) fixed value).

With DHW recirculation pump for domestic hot water tank:

Circulation pump **On** and circulation pump starts according to setting (→ section 6.3.5 on page 47) if one of the heating circuits is running in **Comfort** ☀ mode.

Otherwise circulation pump **Off**.

- **Separate programs** (independent timer programs):
Automatic switching between hot water **On**²⁾ / **Off**²⁾ or different hot water temperatures³⁾ and circulation pump **On** / **Off** according to the set programs.
Circulation pump cycles as per setting (→ Section 6.3.5 on page 47).

For menu structure and adjustment ranges
→ page 35.

- 1) Setting hot water temperature
→ Section 6.3.5 on page 47
- 2) Domestic hot water provided by combi boiler
- 3) Domestic hot water provided by hot water tank

6.3.1 DHW program operating modes

DHW programs operate differently according to the type of domestic hot water system:

- With combination boilers (boilers that produce domestic hot water instantaneously on demand) the DHW program switches between the following operating modes:
 - **On:** if the Eco button on the boiler is not lit, hot water is available immediately on demand (Comfort mode). Solid segments on the display indicate the period for which the operating mode is active.
 - **Off:** the built-in water heater in the boiler is not kept constantly hot (Eco mode); as a result energy is saved. In Eco mode, the hot tap has to be run for a short while before the water becomes hot. Blank segments on the display indicate the period for which the operating mode is active.
- With appliances connected to a domestic hot water tank, the DHW program specifies the desired water temperature (specified temperature).
 - If the temperature measured in the domestic hot water tank is below the specified temperature, the tank is reheated.
 - Once the specified temperature is reached (or exceeded), tank heating is stopped.



If the DHW program changes from a higher to a lower specified temperature, the water in the tank will not immediately cool to the lower temperature, i.e. water at a higher temperature will continue to be available for some time. However, the tank will not be reheated until the temperature falls below the new, lower specified temperature.



The segments on the display show the periods for the following domestic hot water temperature requirements:

≥ 122 °F (≥ 50 °C) – solid segments

≤ 68 °F (≤ 20 °C) – no segments

other – blank segments

6.3.2 Timer program for domestic hot water with combi boiler

Menu: Domestic hot water > DHW program

Use this menu if you wish to use a timer program for the domestic hot water.

The timer program is only programmable and active if **Domestic hot water > DHW and DHW recirculation pump > Separate programs** is set.

For menu structure and adjustment ranges → page 35.

Menu: Domestic hot water > DHW program > Edit

Use this menu if you wish to adjust a timer program for the domestic hot water.

- **Reset factory settings:** Resets DHW program to factory settings → page 26.

For menu structure and adjustment ranges → page 35.

Menu: Domestic hot water > DHW program > Edit > All days

Use this menu to set identical times for every day for the DHW program.

- **P1, P2 ... P6:** Maximum of six switch points per day and two different operating modes (**On/Off**).
 - **On:** if the Eco button on the boiler is not lit, hot water is available immediately on demand (Comfort mode).
 - **Off:** The heating system's heat exchanger is not heated (eco mode) as long as no water is drawn off. This saves energy. Domestic hot water is only available in eco mode after water has been drawn off for a while.
 - The shortest switching interval is 15 minutes (= 1 segment).
 - Deactivate switch points that are not required by deleting them.

For menu structure and adjustment ranges → page 35.

Menu: Domestic hot water > DHW program > Edit > Mon - Fri

Use this menu to set identical times for the days Monday to Friday for the DHW program.

- **P1, P2 ... P6:**
For explanation see **All days** above.

For menu structure and adjustment ranges → page 35.

Menu: Domestic hot water > DHW program > Edit > Sat + Sun

Use this menu to set identical times for Saturday and Sunday for the DHW program.

- **P1, P2 ... P6:**
For explanation see **All days** above.

For menu structure and adjustment ranges → page 35.

Menu: Domestic hot water > DHW program > Edit > Monday, Tuesday... Sunday

Use this menu to set different times for individual days in the DHW program.

- **P1, P2 ... P6:**
For explanation see **All days** above.

For menu structure and adjustment ranges → page 35.

Menu: Domestic hot water > DHW program > View

- ▶ Shows switch points and associated operating modes for **All days, Mon - Fri, Sat + Sun** or the individual day of the week as a segment pattern.

For menu structure and adjustment ranges → page 35.

6.3.3 Time/temperature level program for domestic hot water via tank

Menu: Domestic hot water > DHW program

Use this menu if you want a DHW program with user-defined time/temperature profile. The time/temperature program is only programmable and active if **Domestic hot water > DHW and DHW recirculation pump > Separate programs** is set.

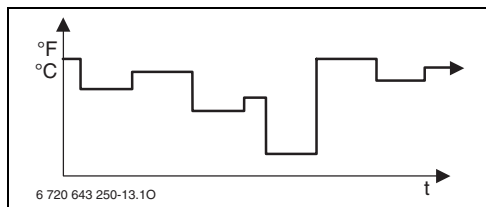

Fig. 21 Example DHW program with time/temperature profile

For menu structure and adjustment ranges → page 35.

Menu: Domestic hot water > DHW program > Edit > All days

Use this menu to set identical times for every day for the DHW program.

- **P1, P2 ... P6:** Maximum of six switch points per day with individual temperature levels (**60 °F (15 °C) ... Maximum tank temperature**).
 - The shortest switching interval is 15 minutes (= 1 segment).
 - Deactivate switch points that are not required by deleting them.

For menu structure and adjustment ranges → page 35.

Menu: Domestic hot water > DHW program > Edit > Mon - Fri

Use this menu to set identical times for the days Monday to Friday for the DHW program.

- **P1, P2 ... P6:**
For explanation see **All days** above.

For menu structure and adjustment ranges → page 35.

Menu: Domestic hot water > DHW program > Edit > Sat + Sun

Use this menu to set identical times for Saturday and Sunday for the DHW program.

- **P1, P2 ... P6:**
For explanation see **All days** above.

For menu structure and adjustment ranges → page 35.

Menu: Domestic hot water > DHW program > Edit > Monday, Tuesday... Sunday

Use this menu to set different times for individual days in the DHW program.

- **P1, P2 ... P6:**
For explanation see **All days** above.

For menu structure and adjustment ranges → page 35.

Menu: Domestic hot water > DHW program > View

- ▶ Shows switch points and associated temperatures for **All days, Mon - Fri, Sat + Sun** or the individual day of the week as a segment pattern.

For menu structure and adjustment ranges → page 35.

6.3.4 Timer program for DHW recirculation pump (systems with domestic hot water tank only)

The recirculation program specifies when a connected secondary circulation pump for domestic hot water runs.

Menu: Domestic hot water > DHW recirc pump prog

Use this menu if you wish to use a timer program for the hot water recirculation pump.

The timer program is only programmable and active if **Domestic hot water > DHW and DHW recirculation pump > Separate programs** is set.

Menu: Domestic hot water > DHW recirc pump prog > Edit > All days

Use this menu to set identical times for every day for the DHW program.

- **P1, P2 ... P6:** Maximum of six switch points per day and two different operating modes (**On/Off**).
 - **On:** Recirculation pump cycles as per setting (→ Section 6.3.5 on page 47). Solid segments on the display indicate the period for which the operating mode is active.
 - **Off:** The recirculation pump is stopped. Blank segments on the display indicate the period for which the operating mode is active.
 - The shortest switching interval is 15 minutes (= 1 segment).
 - Deactivate switch points that are not required by deleting them.

For menu structure and adjustment ranges
→ page 35.

Menu: Domestic hot water > DHW recirc pump prog > Edit > Mon - Fri

Use this menu to set identical times for the days Monday to Friday for the DHW program.

- **P1, P2 ... P6:**

For explanation see **All days** above.

For menu structure and adjustment ranges
→ page 35.

Menu: Domestic hot water > DHW recirc pump prog > Edit > Sat + Sun

Use this menu to set identical times for Saturday and Sunday for the DHW program.

- **P1, P2 ... P6:**

For explanation see **All days** above.

For menu structure and adjustment ranges
→ page 35.

Menu: Domestic hot water > DHW recirc pump prog > Edit > Monday, Tuesday... Sunday

Use this menu to set different times for individual days in the DHW program.

- **P1, P2 ... P6:**

For explanation see **All days** above.

For menu structure and adjustment ranges
→ page 35.

Menu: Domestic hot water > DHW recirc pump prog > View

- ▶ Shows switch points and associated operating modes for **All days, Mon - Fri, Sat + Sun** or the individual day of the week as a segment pattern.

For menu structure and adjustment ranges
→ page 35.

6.3.5 Parameters for domestic hot water

Menu: Domestic hot water > Parameter

- **Tank temp in Comfort Mode:**

This menu option is only active if **Domestic hot water > DHW program > As heating program** is set (→ section 6.3.1 on page 43). This is where you set the desired hot water temperature for your hot water tank.

- **Tank temp in Eco Mode:**

This menu option is only active if **Domestic hot water > DHW program > As heating program** is set (→ section 6.3.1 on page 43). This is where you set the desired reduced domestic hot water temperature for your hot water tank.

- **DHW priority:**

This menu option is only active if the **DHW configuration** in the system configuration is set to **Tank on IPM ID. 3...10** (→ section 8.1.1 on page 58). Use this menu if your heating is not to be switched off during tank heating (e.g. for buildings with limited insulation and low outdoor temperatures).

- **Priority:** The heating is switched off during DHW heating. The pumps stop and the mixers are closed.
- **Conditional priority:** During DHW heating the heating circuits carry on heating, the pumps run and the mixers regulate to the desired temperature. The unmixed heating circuit is switched off to prevent overheating. Tank heating takes longer with **Conditional priority**

- **DHW recirc pump cycles:** This menu option is only active if the system has a hot water recirculation pump. The recirculation pump stops during the recirculation pump **Off** phases. This menu option specifies how many times per hour the recirculation pump will cycle during the recirculation pump **On** phase. With the setting:

- **1 per hour to 6 per hour**, each recirculation pump cycle lasts for 3 minutes.
- **7 per hour**, the recirculation pump runs continuously during the **On** phase.

For menu structure and adjustment ranges → page 35.

6.3.6 Thermal disinfection of domestic hot water

Menu: Domestic hot water > Thermal disinfection

This menu is only active if your hot water is provided by a hot water tank. We recommend that you carry out thermal disinfection at regular intervals. For larger hot water systems, there may be a legal requirement for thermal disinfection. If you have a combi boiler, please refer to the guidance in the boiler documentation.



WARNING: RISK OF SCALDING

Hot water can cause scalding.

- ▶ Only carry out thermal disinfection at times when the system is not normally in use.
- ▶ Inform occupants of the building of the danger of scalding and always monitor the thermal disinfection process.

- **Operating mode:**

- **Auto:** Thermal disinfection starts automatically according to the set starting conditions. The thermal disinfection can be switched on and cancelled manually.
- **Manual:** Thermal disinfection can be started from **Operating status**.

- **Operating status:**

- **Not running:** No thermal disinfection in progress at present. Once-only thermal disinfection can be started by selecting **Start now**.
- **Running:** Thermal disinfection currently in progress. Thermal disinfection can be stopped by selecting **Stop**.

If **Solar sys option E Thermal disinfection** is switched on (→ Section 8.4 on page 72) and thermal disinfection is stopped by selecting **Stop**, a fault is indicated for 5

minutes if the disinfection temperature in the solar tank has not been reached (Fault 54, → Section 9.1 starting on page 86).

- **Time:** Starting time for automatic thermal disinfection.
- **Time interval:** Period until next starting time for automatic thermal disinfection.



If you want to use automatic thermal disinfection (e.g. once a week), proceed as follows:

- ▶ Set the required time interval (e.g. 7d, i.e. 7 days).
- ▶ Set the required start time (e.g. 10:00pm (22:00)).
- ▶ Set the operating mode **to Auto on the day** on which you want thermal disinfection to take place.

For menu structure and adjustment ranges
→ page 35.

6.4 General settings

6.4.1 Time, Date

Menu: General settings > Time and date

Use this menu if you want to correct the date and time.

- **Time:** Resets the time, e.g. power was lost for more than 12 hours.
- **Date** see above **Time**.
The current day of the week (e.g. **Mo**) is calculated automatically.
- **Time adjustment:** Sets the adjustment factor for the time. The adjustment is carried out once a week.
Example:
 - If the time is off by approximately – 3 minutes a year
 - – 3 minutes a year is equal to
 - 180 seconds a year
 - 1 year = 52 weeks
 - – 180 seconds ÷ 52 weeks
 - = – 3.46 seconds a week
 - Correction factor = **+3.5 sec/week**

For menu structure and adjustment ranges
→ page 37.

6.4.2 Display formats

Menu: General settings > Display format

Use this menu if you want to customize the display formats to suit your personal preferences.

- **Time:** Select format for time display between **12 am/pm** or **24h**.
- **Date:** Selects either **MM/DD/YYYY** or **DD.MM.YYYY** as date display format (D = number for day, M = number for month, Y = number for year).

- **Temperature unit:** Select unit for the displayed temperatures, areas, and quantities of energy:
 - °C: temperatures in °C, areas in m², energy quantities in Wh or kWh
 - °F: temperatures in °F, areas in sq.ft., energy quantities in BTU or MBTU
- **Display contrast:** Sets display contrast to between **25%** and **75%**.
- **Information at top of display:** Sets the desired information to be shown on the top line of the basic display.



For menu structure and adjustment ranges
→ page 37.

6.4.3 Key lock

- **Key lock:** Use this menu option to prevent unwanted operation of the button functions, e.g. by children.
 - If a locked button is pressed when the **Key lock** is active and the screen is showing the basic display, an appropriate message appears.



If the mode selector is set to a different mode, it does not become active until the **Key lock** is cancelled.

- ▶ To cancel **Key lock**:
Press and hold  and  simultaneously until the relevant message appears.

For menu structure and adjustment ranges
→ page 37.

6.4.4 Language

- **Language:** Use this menu option if you want to set a different language for the display.

For menu structure and adjustment ranges
→ page 37.

6.5 Solar settings

Main menu: Solar

Use this menu if you want to limit the tank temperature or optimize the specified domestic hot water temperature and specified supply temperatures based on the available solar energy in your geographical region.

Limiting tank temperature(s)

To store as much solar energy as possible, a high tank temperature is required.

Limiting the tank temperature prevents overheating of the domestic hot water. The temperature setting is transmitted by the ISM module during commissioning.



WARNING: Danger of scalding if the tank temperature is higher than 140 °F (60 °C).

- ▶ If the tank temperature limit is set > 140 °F (> 60 °C) install a thermostatic mixing valve in the hot water supply.
- ▶ Set the domestic hot water mixer unit to 140 °F max. (60 °C).

- **T2: Max. temperature solar tank:** Set tank temperature > 140 °F (> 60 °C) with domestic hot water tanks only if hot water outlet temperature is limited by a thermostatic mixing valve.

When using solar buffer tanks, e.g. in space heating (system 2), **T2: Max. solar tank temperature** can be set higher.

- **TB: Max. temperature tank B:** This parameter is only active with a solar recharge system (solar option B). Tank temperature > 140 °F (> 60 °C) only if hot water outlet temperature is limited by thermostatic DHW mixer unit.
- **TC: Max. temperature tank C:** This parameter is only active with a solar high/low priority system (solar option C)¹⁾ or with space heating. Tank temperature > 140 °F (> 60 °C) for DHW tanks only if hot water outlet temperature is limited by thermostatic DHW mixer unit.
This mechanical temperature limitation is not required if the tank C is a buffer tank. In this case, **TC: Max. temperature tank C** can also be set higher.

For menu structure and adjustment ranges
→ page 38.

1) For an overview of the possible solar systems, see the installation instructions for the ISM module.

Solar optimization

To use as much solar energy as possible, the FW 200 heating controls can estimate the expected solar yield during the course of the day and take this into account in controlling the boiler. The boiler will then not be required to produce as much heat and will use less gas.

For more information for installers, see
→ Section 8.5.10 on page 80

- **Optimizing influence DHW:** maximum reduction of specified hot water temperature by effect of solar thermal system.

Example:

- DHW set temperature = 140 °F (60 °C)

DHW optimization = 28 °F (15 °C)

Specified domestic hot water temperature for the boiler = 140 °F – 28 °F
(60 °C – 15 °C)

Provided there is sufficient solar output available, the maximum reduction is set and the boiler heats the domestic hot water to 114 °F (45 °C), with the remaining 28 °F (15 °C) being provided by the solar contribution.

- **Heating circuit 1 optimization:** Influence of solar output on heat output that feeds into the heating circuit 1. At a high value, the preheat temperature of the heating curve is reduced at a correspondingly greater rate (further information for installers → section 8.3.1 and 8.3.2 from page 67) to enable greater passive solar energy input through the building's windows. At the same time this reduces a temperature overshoot in the building and increases the comfort level.
 - Increase **Heating circuit 1 optimization** if the heating circuit 1 heats rooms that have large areas of south-facing windows.
 - Do not increase **Heating circuit 1 optimization** if the heating circuit 1 heats rooms that have small areas of north-facing windows.

- **Heating circuit 2 optimization:** Take the steps described under **Heating circuit 1 optimization**.



DHW optimization and **Heating circuit optimization** start after a calibration phase of 30 days after the solar heating system is set up at the earliest. During this period the FW 200 heating controls learn the potential solar input.

For menu structure and adjustment ranges
→ page 38.

7 Viewing information

Menu INFO

This menu allows you to view a variety of system information.

Detailed instructions on navigating through the menu structure are provided in Section 5.2 starting on page 23.



The menu options are only shown if the system components are present and/or active and if no remote control is accessing these. Some menu options are not shown because they are switched off by a setting for another menu option.

INFO menu overview

The table below provides



- an overview of the menu structure (column 1). The menu depth is identified by various shades of gray. E.g. the **Instruction manual** and **Boiler** menus are on the same level.
- an overview of the various display options (column 2).
- descriptions of the individual information items (column 3).

Menu structure INFO	Display (example)	Description
Boiler	–	–
Outdoor temperature	50.0 °F (10.0 °C)	Current outdoor temperature
Heating mode possible	Yes No	Shows whether boiler is ready for operation.
Current heating supply temperature	131.0 °F (55.0 °C)	Current boiler supply temperature.
External supply temperature	131.0 °F (55.0 °C)	Supply temperature after the low-loss header.
Burner	On Off	Burner status.
Heating pump	On Off	Status of pump in the boiler.
Maximum heating supply temperature	167.0 °F (75.0 °C)	Maximum supply temperature set on the boiler.
Maximum DHW temperature	140.0 °F (60.0 °C)	Maximum hot water temperature set on the boiler.
Service due	Yes No	Shows whether a boiler service/inspection is due.

Menu structure INFO	Display (example)	Description
Heating circuit 1	–	–
Operating mode	Auto - Comfort Auto - Economy Auto - Frost Comfort Economy Frost Vacation - Auto Vacation - Comfort Vacation - Economy Vacation - Frost Slab drying waiting Slab drying running	Current operating mode for heating circuit 1.
Desired room temperature	77.0 °F (25.0 °C)	Room temperature provided by controls for heating circuit 1 (only if the room temperature hook-up is activated).
Current room temperature	71.6 °F (22.0 °C)	Room temperature measured at the controls (only with wall-mounted controls).
Desired heating supply temperature	167.0 °F (75.0 °C)	Supply temperature for heating circuit 1 calculated and required by the controls.
Current heating supply temperature	116.6 °F (47.0 °C)	Supply temperature measured in heating circuit 1.
Heating pump	On Off	Heating pump switching status in heating circuit 1.
Current mixer setting	85% open	Current opening of mixer in heating circuit 1.
Heating circuit 2	–	–
Operating mode	Auto - Comfort Auto - Economy Auto - Frost Comfort Economy Frost Vacation - Auto Vacation - Comfort Vacation - Economy Vacation - Frost Slab drying waiting Slab drying running	Current operating mode for heating circuit 2.
Desired room temperature	73.4 °F (23.0 °C)	Room temperature provided by controls for heating circuit 2 (only if the room temperature hook-up is activated).
Current room temperature	68.0 °F (20.0 °C)	Room temperature measured at the controls (only with wall-mounted controls).
Desired heating supply temperature	152.6 °F (67.0 °C)	Supply temperature for heating circuit 2 calculated and required by the controls.
Current heating supply temperature	116.6 °F (47.0 °C)	Supply temperature measured in heating circuit 2.
Heating pump	On Off	Heating pump switching status in heating circuit 2.
Current mixer setting	62% open	Current opening of mixer in heating circuit 2.

Menu structure INFO	Display (example)	Description
Domestic hot water	–	–
Operating mode	DHW single charge Auto ON Auto OFF Vacation - Auto Vacation ON Vacation OFF	Current operating mode or special mode for domestic hot water with combi boiler.
	DHW single charge Thermal disinfection Auto Vacation - Auto Vacation 60 °F (15 °C)	Current operating mode or special mode for domestic hot water tank.
Desired DHW temperature	140 °F (60 °C)	Hot water temperature required by controls.
Current DHW temperature	104 °F (40 °C)	Current measured hot water temperature.
DHW status	Running Off	Current status of hot water system.
Last thermal disinfection	Completed Cancelled Running	Status of last thermal disinfection.
Customer service		Only available if the Cust service address in the INSTALLER SETTINGS has been changed.
Telephone number	(Telephone number)	Telephone number of installer (system installer).
Name	(Name)	Name of installer (system installer).
Solar	–	–
Standard system	–	Menu for basic system component of solar thermal system.
T1: Temperature of collector field 1	176.0 °F (80.0 °C)	Temperature measured by collector temperature sensor (T_1).
T2: Temp at bottom of solar tank	132.2 °F (55.7 °C)	Temperature measured at lower tank temperature sensor (T_2) in the solar tank.
SP: Collector field 1 pump status	Running Off	Status of solar pump (SP).
Collector field 1 shut down	Yes No	Shows whether there has been an emergency shutdown of the solar pump (SP) due to the collectors overheating (T_1).
Solar tank status	Fully charged Partially charged	Charge status of solar tank.
SP: Collector field 1 pump run time SP: Collector field 1 pump run time	12463hr	Hours of duty of the solar pump (SP) since commissioning.
Heating assistance	–	Menu for the system part solar central heating boost.
T3: Tank temp at heating return	113.2 °F (45.1 °C)	Temperature measured at lower tank temperature sensor (T_3) in the solar combi tank.
T4: heating return temperature	96 °F (35.5 °C)	Heating return temperature measured at the temperature sensor (T_4).

Menu structure INFO		Display (example)	Description
	DWU1: High return valve status	On Off	Status of the valve DWU1, for return temperature raising
	Solar heating support status	On Off	Shows whether solar energy is currently available for the heating network.
	collector field 2	–	Menu for the system part 2nd collector field
	TA: Temperature of collector field 2	189.4 °F (87.4 °C)	Temperature measured by collector temperature sensor (TA) in 2nd collector field.
	PA: Collector field 2 pump status	Running Off	Switch status of solar pump (SP) for the 2nd collector field.
	Collector field 2 shut down	Yes No	Shows whether there has been an emergency shutdown of the solar pump (PA) due to the collectors overheating (TA).
	PA: Coll field 2 pump run time	5370hr	Number of hours of duty of the solar pump (SP) for the 2nd collector field since commissioning.
	Reload system	–	Menu for the system part drinking water reload.
	TB: Temp at top of tank B	137.6 °F (58.7 °C)	Temperature measured at top tank temperature sensor (TB) in the solar tank B.
	PB: DHW reload pump status	Running Off	Switch state of the drinking water reload pump
	Tank B status	Fully charged Partially charged	Load status tank B.
	High/low priority	–	Menu for the system part low/high priority tank system.
	TC: Temp at bottom of tank C	140.6 °F (60.3 °C)	Temperature measured at bottom tank temperature sensor (TC) in the solar tank C.
	Currently charging	Tank C Solar tank	Shows which tank is currently being charged (the solar tank or tank C).
	PC: Solar pump status	On Off	Status of the second solar pump (PC) in the high/low priority system.
	DWUC: Hi/lo priority valve status	On Off	Status of the high/low valve (DWUC) in the high/low priority system.
	Tank C status	Fully charged Partially charged	Charge status tank C.
	Priority tank charging test	Running Off	Status of the test mode for charging the priority tank
	Next priority tank charging test at	5:30pm (17:30)	Time for the next test for charging the priority tank.
	Ext. heat exchanger	–	Menu for the system part external solar heat exchanger.
	TD: External heat exchanger temp	211.6 °F (99.8 °C)	Temperature measured on the temperature sensor (TD), external heat exchanger
	PD: Secondary circuit pump status	Running Off	Switch state of the high/low priority valve between the external heat exchanger and the tank.

Menu structure INFO	Display (example)	Description
Thermal disinfection	–	Menu for thermal disinfection part of the system.
PE: Therm disinfect pump status	Running Off	Status of thermal disinfection pump (PE).
Solar optimization	–	Menu for solar-assisted optimization of conventional heating system.
Solar yield last hour	409 BTU (120 Wh)	Solar energy yield in the last hour (a figure is only shown if correct parameters have been set on the Solar optimization menu, → Section 8.5.10 on page 80).
Solar yield today	8.12 MBTU (2.38 kWh)	Solar energy yield for the current 24 hour period.
Solar yield overall	1649.1 MBTU (483.6 kWh)	Total solar energy yield since commissioning.
DHW temperature reduced by	8.4 °F (4.7 °C)	Current reduction of the specified domestic hot water temperature required by the boiler as a result of the available solar energy. Does not start until at least 30 days after commissioning.
Desired room temp HC 1 reduced by	2.4 °F (1.3 °C)	Current reduction of desired room temperature for heating circuit based on available solar energy. Does not start until at least 30 days after commissioning.
Desired room temp HC 2 reduced by	2.4 °F (1.3 °C)	Current reduction of desired room temperature for heating circuit 2 based on available solar energy. Does not start until at least 30 days after commissioning.
Faults	40 Solar system 03 FW 200 EA Boiler ...	List of current faults. More detailed information can be obtained by selecting with the dial  and then pressing the dial  to confirm.

8 Menu settings **INSTALLER SETTINGS** (for installers only)



The **INSTALLER SETTINGS** menu is intended only for installers.

- ▶ To open **INSTALLER SETTINGS**: press and hold  for approx. 3 seconds.

Moving through menu structure, programming, deleting values and reverting to the default setting are described in detail in section 5.2 from page 23.

8.1 **INSTALLER SETTINGS** menu summary and settings

The tables set out below provide

- an overview of the menu structure (column 1). The menu depth is identified by various shades of gray. E. g. in the **Heating parameters** menu the submenus **Heating circuit 1**, **Heating circuit 2**, **Minimum outdoor temperature** and **Building storage capacity** are on the same level.
- an overview of the factory settings (column 2), e.g. for the purposes of resetting individual menu options to the factory settings.
- an overview of the adjustment ranges of the individual menu options (column 3).
- space for making a note of your personal settings (column 4).
- references to the detailed descriptions of the individual menu options (column 5).



The menu options are only shown if the system components are present and/or active and if no remote control is accessing these. Some menu options are not shown because they are switched off by a setting for another menu option.

- ▶ Always set or skip menu options in order. In that way, subsequent menu options will be automatically adjusted or not shown.

8.1.1 INSTALLER SETTINGS: System configuration

Menu structure	Default setting	Control range	Personal setting	Description starts on page
System configuration				
Start automatic system configuration	No	No Yes		66
DHW configuration	Combi boiler	No Combi boiler Tank on boiler Tank on IPM ID. 3 ... 10		
Maximum tank temperature	140 °F (60 °C)	140 °F ... 176 °F (60 °C ... 80 °C)	°F (°C)	
DHW recirculation pump	No	No Present		
Heating circuit 1 configuration	Unmixed without IPM	No Unmixed without IPM Unmixed with IPM Mixed		
Heating circuit 1 remote control	No	No FB 100		
Heating circuit 2 configuration	No	No Unmixed without IPM Unmixed with IPM Mixed		
Heating circuit 2 remote control	No	No FB 100		
ISM 2	No	No Present		

8.1.2 INSTALLER SETTINGS: Heating parameters

Menu structure	Default setting	Control range	Personal setting	Description starts on page
Heating parameters				
Heating circuit 1	–	–		–
Heating circuit type	Radiators	Baseline/Design temp Radiant Floor Radiators Baseboard		
Base line	78 °F (25 °C)	50 °F ... 186 °F (10 °C ... 85 °C)	°F (°C)	
Design Temp	168 °F (75 °C)	86 °F ... 186 °F (30 °C ... 85 °C)	°F (°C)	
Design supply temp.	168 °F (75 °C)	86 °F ... 186 °F (30 °C ... 85 °C)	°F (°C)	
Maximum heating supply temperature	176 °F (80 °C)	86 °F ... 186 °F (30 °C ... 85 °C)	°F (°C)	
Room influence	30%	0% ... 100%		%
Room influence enabled for modes	Eco/Frost	Eco/Frost Comfort/Eco/Frost		
Room temperature offset	0 °F (0.0 °C)	– 9 °F ... 9 °F (– 5.0 °C ... 5.0 °C)	°F (°C)	68
Heating OFF until lower level reached	Yes	No Yes		
Heating OFF at outdoor temperature	68 °F (20.0 °C)	50 °F ... 77 °F (10.0 °C ... 25.0 °C), 210 °F (99.0 °C) (= function off)	°F (°C)	
Risk of freezing at outdoor temperature	38 °F (3.0 °C)	23 °F ... 50 °F (– 5.0 °C ... 10.0 °C)	°F (°C)	
Mixer run time	140 s	10 s ... 600 s		s
Heating circuit 2	–	–		–
Heating circuit type	Radiators	Baseline/Design temp Radiant Floor Radiators Baseboard		
Base line	78 °F (25 °C)	50 °F ... 186 °F (10 °C ... 85 °C)	°F (°C)	
Design Temp	168 °F (75 °C)	86 °F ... 186 °F (30 °C ... 85 °C)	°F (°C)	
Design supply temp.	168 °F (75 °C)	86 °F ... 186 °F (30 °C ... 85 °C)	°F (°C)	
Maximum heating supply temperature	176 °F (80 °C)	86 °F ... 186 °F (30 °C ... 85 °C)	°F (°C)	
Room influence	30%	0% ... 100%		%
Room influence enabled for modes	Eco/Frost	Eco/Frost Comfort/Eco/Frost		
Room temperature offset	0 °F (0.0 °C)	– 9 °F ... 9 °F (– 5.0 °C ... 5.0 °C)	°F (°C)	68
Heating OFF until lower level reached	Yes	No Yes		
Heating OFF at outdoor temperature	68 °F (20.0 °C)	50 °F ... 77 °F (10.0 °C ... 25.0 °C), 210 °F (99.0 °C) (= function off)	°F (°C)	
Risk of freezing at outdoor temperature	37.4 °F (3.0 °C)	23.0 °F ... 50.0 °F (– 5.0 °C ... 10.0 °C)	°F (°C)	
Mixer run time	140 s	10 s ... 600 s		s

Menu structure	Default setting	Control range	Personal setting	Description starts on page
Heating parameters				
Minimum outdoor temperature	5 °F (- 15 °C)	- 22 °F ... 32 °F (- 30 °C ... 0 °C)	°F (°C)	67
Building storage capacity	50%	0% ... 100%	%	
Calibrate internal room temp sensor	0.0 °F (0.0 °C)	- 5.4 °F ... 5.4 °F (- 3.0 °C ... 3.0 °C)	°F (°C)	

8.1.3 INSTALLER SETTINGS: Solar system config

Menu structure	Default setting	Control range	Personal setting	Description starts on page
Solar system config				
Solar system	1. Standard system	1. Standard system 2. Heating support		72
Solar sys option A 2 collector fields	No	No Yes		
Solar sys option B Reloading system	No	No Yes		
Solar sys option C high/low priority	No	No Yes		
Solar sys option D Ext heat exchanger	No	No Yes		
Solar sys option E Thermal disinfection	No	No Yes		

8.1.4 INSTALLER SETTINGS: Solar sys parameters

Menu structure	Default setting	Control range	Personal setting	Description starts on page
Solar sys parameters				
1. Standard system	–	–	–	–
SP: ON delta T	14 °F (8 °C)	6 °F ... 36 °F (3 °C ... 20 °C) (not lower than "SP: OFF delta T" +2 °F (+1 °C))	°F (°C)	73
SP: OFF delta T	8 °F (4 °C)	4 °F ... 34 °F (2 °C ... 19 °C) (not higher than "SP: ON delta T" – 2 °F (– 1 °C))	°F (°C)	
T2: Max. solar tank temperature	140 °F (60 °C)	Disabled (<60 °F or <15 °C) 60 ... 194 °F (15 °C ... 90 °C)	°F (°C)	
Maximum collector temperature	248 °F (120 °C)	212 °F ... 284 °F (100 °C ... 140 °C)	°F (°C)	
SP: Collector field 1 pump mode	Auto	Auto Manual ON Manual OFF		
2. Heating support	–	–	–	–
DWU1: ON delta T	10 °F (6 °C)	6 °F ... 36 °F (3 °C ... 20 °C) (not lower than "DWU1: OFF delta T" +2 °F (+1 °C))	°F (°C)	74
DWU1: OFF delta T	6 °F (3 °C)	4 °F ... 34 °F (2 °C ... 19 °C) (not higher than "DWU1: ON delta T" – 2 °F (– 1 °C))	°F (°C)	
DWU1: High return valve mode	Auto	Auto Manual ON Manual OFF		
DWU1: High return valve switch signal	Not reversed	Not reversed Reversed		
A collector field 2	–	–	–	–
PA: ON delta T	14 °F (8 °C)	6 °F ... 36 °F (3 °C ... 20 °C) (not lower than "PA: OFF delta T" +2 °F (+1 °C))	°F (°C)	75
PA: OFF delta T	8 °F (4 °C)	4 °F ... 34 °F (2 °C ... 19 °C) (not higher than "PA: ON delta T" – 2 °F (– 1 °C))	°F (°C)	
PA: Collector field 2 pump mode	Auto	Auto Manual ON Manual OFF		

Menu structure	Default setting	Control range	Personal setting	Description starts on page
B Reload sys	–	–	–	
PB: ON delta T	10 °F (6 °C)	6 °F ... 36 °F (3 °C ... 20 °C (not lower than "PB: OFF delta T" +2 °F (+1 °C))	°F (°C)	76
PB: OFF delta T	6 °F (3 °C)	4 °F ... 34 °F (2 °C ... 19 °C) (not higher than "PB: ON delta T" – 2 °F (– 1 °C))	°F (°C)	
TB: Max. temperature tank B.	158 °F (70 °C)	Disabled (<60 °F or <15 °C) 60 ... 194 °F (15 °C ... 90 °C)	°F (°C)	
PB: DHW reload pump mode	Auto	Auto Manual ON Manual OFF		
C High/low priority	–	–	–	
High/low priority system type	Pump/ Pump	Pump/Pump Pump/Valve		76
TC: Max. temperature tank C	140 °F (60 °C)	Disabled (<60 °F or <15 °C) 60 ... 194 °F (15 °C ... 90 °C)	°F (°C)	
Priority tank	Solar tank	Solar tank Tank C		
Charge switchover test duration	10 min	2 min ... 60 min (not more than 0.5 x "Charge switchover test interval")	min	
Charge switchover test interval	30 min	4 min ... 120 min (not less than 2 x "Charge switchover test duration")	min	
DWUC: HI/LO priority valve signal	Not reversed	Not reversed Reversed		
PC: Solar pump mode	Auto	Auto Manual ON Manual OFF		
DWUC: High/low priority valve mode	Auto	Auto Manual ON Manual OFF		
D Ext heat exchanger	–	–	–	
PD: ON delta T	10 °F (6 °C)	6 °F ... 36 °F (3 °C ... 20 °C (not lower than "PD: OFF delta T" +2 °F (+1 °C))	°F (°C)	78
PD: OFF delta T	6 °F (3 °C)	4 °F ... 34 °F (2 °C ... 19 °C) (not higher than "PD: ON delta T" – 2 °F (– 1 °C))	°F (°C)	
PD: Secondary circuit pump mode	Auto	Auto Manual ON Manual OFF		
E Therm disinfection				
Solar tank thermal disinfection	Yes	No Yes		79
Thermal disinfection tank B	No	No Yes		
Thermal disinfection tank C	No	No Yes		
PE: Therm disinfect pump mode	Auto	Auto Manual ON Manual OFF		

Menu structure	Default setting	Control range	Personal setting	Description starts on page
Solar sys parameters				
Solar optimization				80
Collector field 1 area	0.0 sq.ft. (0.0 m ²)	0.0 sq.ft ... 1614.6 sq.ft (0.0 m ² ... 150.0 m ²)	sq.ft. (m ²)	
Collector field 1 type	Flat plate collector	Flat plate collector Vac.tube collector		
Collector field 2 area	0.0 sq.ft. (0.0 m ²)	0.0 sq.ft ... 1614.6 sq.ft (0.0 m ² ... 150.0 m ²)	sq.ft. (m ²)	
Collector field 2 type	Flat plate collector	Flat plate collector Vac.tube collector		
Climate zone	90	0 ... 255		
DHW optimization	0 °F (0 °C)	0 °F (0 °C)(= function off) ... 36 °F (20 °C)	°F (°C)	
Heating circuit 1 optimization	0 °F (0.0 °C)	0 °F (0.0 °C) (= function off) ... 9 °F (5.0 °C)	°F (°C)	
Heating circuit 2 optimization	0 °F (0.0 °C)	0 °F (0.0 °C) (= function off) ... 9 °F (5.0 °C)	°F (°C)	
Run solar system	No	No Yes		73
Reset factory settings	No	No Yes		73

8.1.5 INSTALLER SETTINGS: Fault history

Menu structure	Default setting	Control range	Personal setting	Description starts on page
Fault history				
01/01/2010 04:11pm EA Boiler (example for last fault)	-	-	-	82
09/25/2010 06:45pm 32 IPM ID 10 (up to maximum of 19 past faults)	-	-	-	

8.1.6 INSTALLER SETTINGS: Cust service address

Menu structure	Example	Control range	Personal setting	Description starts on page
Cust service address				
Telephone number	012345 6789	Max. 20 characters		82
Name	Installer	Max. 20 characters		

8.1.7 INSTALLER SETTINGS: System info

Menu structure			Personal setting	Description starts on page
System info	Example	Control range		
Installation date	10/22/2010 (activated on commissioning)	–		–
Boiler part number	7 777 777 777 (data from boiler)	–		–
Boiler date of manufacture	06/27/2010 (data from boiler)	–		–
Controller part number and model	7 777 777 777 FW 200 (fixed factory setting)	–		–
Controller date of manufacture	06/27/2010 (fixed factory setting)	–		–
Controller software version	JF11.12 (fixed factory setting)	–		–

83

8.1.8 INSTALLER SETTINGS: Slab drying

Menu structure	Default setting	Control range	Personal setting	Description starts on page
Slab drying				
Cancel slab drying ¹⁾	No	No/Yes		83
Maximum heating supply temperature	78 °F (25 °C)	78 °F ... 140 °F (25 °C ... 60 °C)	°F (°C)	
Maintain max heating supply temp for	1 d	1 d ... 20 d	d	
Total slab drying time	calculated	calculated... 60 d (not higher than “Maintain max heating supply temp for”)	-	
Start date	- - . - - - - - - -	Today ... 12/31/2099 (in increments of one day/ month/year)		
Start time	- - : - -	12:00am ... 11:59pm (in increments of one hour/ minute)		

1) Only available if “Slab drying is active.”

8.1.9 INSTALLER SETTINGS: Output test

Menu structure	Default setting	Control range	Personal setting	Description starts on page
Output test				
Stop all output tests	No	No Yes		83
Pump, heating circuit 1	Auto	Auto Manual ON Manual OFF		
Pump, heating circuit 2	Auto	Auto Manual ON Manual OFF		
Mixer, heating circuit 1	Auto	Auto Manual 100 % open Manual 50 % open Manual 0 % open		
Mixer, heating circuit 2	Auto	Auto Manual 100 % open Manual 50 % open Manual 0 % open		
Tank charge pump	Auto	Auto Manual ON Manual OFF		
DHW recirculation pump	Auto	Auto Manual ON Manual OFF		

8.2 Configuring the heating system

Installer settings: System configuration

For menu structure and adjustment ranges

→ page 58.



For system examples, see the instructions for the IPM Other examples can be found in the planning documents.

Use this menu if you want to configure the system automatically or manually. E.g. on commissioning the system for the first time or making changes to it.

- **Start automatic system configuration** for starting automatic configuration.
- **DHW configuration** for manual configuration of the domestic hot water system.
- **Maximum tank temperature:** This menu option is only available if tank is in use.



WARNING: Danger of scalding if the tank temperature is higher than 140 °F (60 °C).

- ▶ If the tank temperature limit is set > 140 °F (> 60 °C) install a thermostatic water mixer in the hot water supply.
- ▶ Set the domestic hot water mixer unit to 140 °F max. (60 °C).

- **DHW recirculation pump:** This menu option is only active if the domestic hot water system has a hot water recirculation pump.
- **Heating circuit 1 configuration** for configuring the heating circuit 1.
- **Heating circuit 1 remote control** for deactivating or activating the remote control on the heating circuit 1.

- **Heating circuit 2 configuration** for configuring the heating circuit 2.
- **Heating circuit 2 remote control** for deactivating or activating the remote control on the heating circuit 2.
- **ISM 2** for heating systems with solar hot water system or heating boost.

When first commissioning a heating system, proceed as follows:

- ▶ Set ID of all BUS devices according to their function (e.g. IPM2 for heating circuit 1 and heating circuit 2, etc.).
- ▶ Start automatic configuration.
- ▶ Check the other menu options under **System configuration** and, if necessary, adjust to suit the present system.



The heating system's solar thermal system must be configured manually (→ Section 8.4, page 72). Automatic configuration of the heating system does not configure the solar system.

For menu structure and adjustment ranges
→ page 58.

8.3 Parameters for heating

Installer settings: Heating parameters



Set the supply temperature control on the boiler to the maximum required supply temperature.

Use this menu if you want to set the parameters for the entire heating system or for individual heating circuits controlled by the FW 200 controls. For example, the heating curves can be calculated with these parameters.

8.3.1 Parameters for the entire heating system

Installer settings: Heating parameters

- **Minimum outdoor temperature:** Set the expected minimum outdoor temperature under this item (model for the whole heating system) (guide values → Fig. and table 6). Low outdoor temperatures produce a flat heating curve.

City	Minimum outdoor temperature in °F (°C)	City	Minimum outdoor temperature in °F (°C)
Bermuda	59 (15)	Montreal	- 9 (- 23)
Boston	0 (- 18)	New Orleans	19 (- 7)
Cleveland	- 4 (- 20)	New York	0 (- 18)
Chicago	- 9 (- 23)	Ottawa	- 9 (- 23)
Dallas	10 (- 12)	Pittsburgh	- 4 (- 20)
Detroit	- 9 (- 23)	Quebec	- 15 (- 26)
Honolulu	59 (15)	San Francisco	36 (2)
Houston	19 (- 7)	Toronto	- 9 (- 23)
Los Angeles	36 (2)	Washington	0 (- 18)
Miami	36 (2)		

Tab. 6 Minimum outdoor temperatures for North America

- **Building storage capacity:** Use this menu option to set the factor for the heat storage capacity of the building.
 - ≥ **50%:** Building of solid construction (e.g. well insulated brick house).
 - ≤ **50%:** Building of light construction (e.g. wood or steel frame structure).
- **Calibrate internal room temp sensor:** This menu option only appears if the controls are wall-mounted. Use this menu option if you want to correct the displayed room temperature.
 - ▶ Position a precision instrument near FW 200. The precision instrument must not transfer any heat to the FW 200.
 - ▶ Keep away from heat sources such as sunlight, body heat, etc. for 1 hour.
 - ▶ Determine the displayed temperature differential ($T_{\text{Reference}} - T_{\text{FW 200}}$) and set as correction value.

For menu structure and adjustment ranges → page 58.

8.3.2 Heating circuit parameters

Menu: Heating parameters > Heating circuit 1 ...

Heating circuit 2

- **Heating circuit type:** Use this menu option to set the heating type for the **Heating circuit 1** and/or **Heating circuit 2**:
 - **Baseline/Design temp:** Default settings for a level heating curve are used according to the classic base point/end point method.
 - **Radiant Floor:** Default settings for an uneven heating curve as in a radiant floor heating circuit are used.
 - **Radiators:** Default settings for an uneven heating curve as in a radiator heating circuit are used.
 - **Baseboard:** Default settings for an uneven heating curve as in a convector heating circuit are used.



Parameters not used in a particular type of heating are not shown.

For menu structure and adjustment ranges

→ page 58.

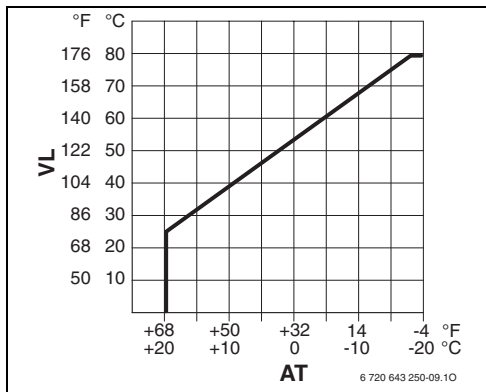

Fig. 22 Factory setting of heating curve for base point/end point

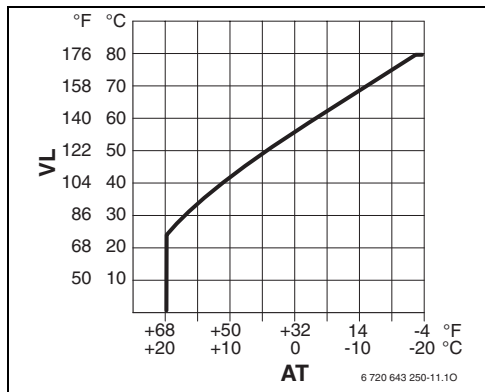

Fig. 24 Factory setting for heating curve in radiator heating system

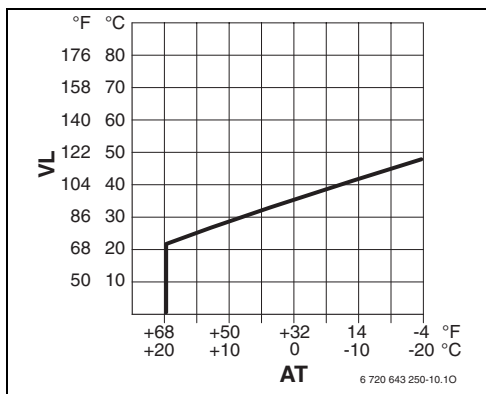

Fig. 23 Default setting for heating curve in radiant floor heating

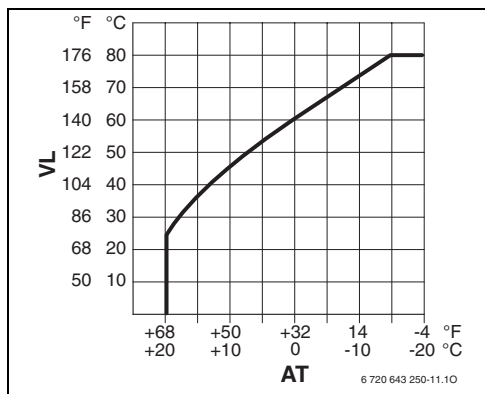

Fig. 25 Factory setting for heating curve in convector heating system

AT Outdoor temperature

VL Supply temperature

Factory setting of parameters for heating curve	Baseline/Design temp	Radiant Floor	Radiators	Baseboard
Heating surface exponent (fixed value), curvature of heating curve	–	1.1	1.3	1.4
Minimum outdoor temperature	–	6 °F (– 15 °C)	6 °F (– 15 °C)	6 °F (– 15 °C)
Base line	78 °F (25 °C)	–	–	–
Design Temp	168 °F (75 °C)	–	–	–
Design supply temp.	–	114 °F (45 °C)	168 °F (75 °C)	176 °F (80 °C)
Maximum heating supply temperature	176 °F (80 °C)	132 °F (55 °C)	176 °F (80 °C)	176 °F (80 °C)
Room temperature offset	0 °F (0.0 °C)	0 °F (0.0 °C)	0 °F (0.0 °C)	0 °F (0.0 °C)
Heating OFF at outdoor temperature	68 °F (20 °C)	68 °F (20 °C)	68 °F (20 °C)	68 °F (20 °C)

Tab. 7

- **Base line:** Use this menu option to set the base point of the heating curve according to the traditional base point/end point method **Heating circuit 1** and/or **Heating circuit 2**.
- **Design Temp:** Use this menu option to set the base point of the heating curve according to the traditional base point/end point method **Heating circuit 1** and/or **Heating circuit 2**.
- **Design supply temp.:** Use this menu option to adapt the supply temperature setting to the heating type for the **Heating circuit 1** and/or **Heating circuit 2**.
 - For **Radiant Floor** e.g. 114 °F (45 °C) supply temperature setting.
 - For **Radiators** e.g. 168 °F (75 °C) supply temperature setting.
 - For **Baseboard** e.g. 176 °F (80 °C) supply temperature setting.
- **Maximum heating supply temperature:** Use this menu option to adapt the supply temperature setting to the heating type for the **Heating circuit 1** and/or **Heating circuit 2**.
 - For **Radiant Floor** e.g. 132 °F (55 °C) maximum supply temperature.
 - For **Radiators** e.g. 176 °F (80 °C) maximum supply temperature.
 - For **Baseboard** e.g. 176 °F (80 °C) maximum supply temperature.
- **Room influence:** This menu option only appears if the controls are wall-mounted. Use this menu option to set the room temperature influence on the heating curve for the **Heating circuit 1** and/or **Heating circuit 2**.
 - **0%:** No room temperature influence
 - **100%:** Maximum room temperature influence
- **Room influence enabled for modes:** Use this menu option to select the operating modes where the room temperature influence is to be active for **Heating circuit 1** and/or **Heating circuit 2**.
 - **Eco/Frost:** Room temperature influence is only active in these operating modes.
 - **Comfort/Eco/Frost:** Room temperature influence is always active.
- **Room temperature offset:** Use this menu option to set the permanent increase in required room temperature for the **Heating circuit 1** and/or **Heating circuit 2**, e.g. to correct system-related variations.

- **Heating OFF until lower level reached:** Use this menu option to select the cooling down phase for the **Heating circuit 1** and/or **Heating circuit 2**:
 - **No:** Heating mode corresponds to the heating curve.
 - **Yes:** Heating mode corresponds to the heating curve but without heating in the cooling down phase. Only at the point when the room temperature reaches the required room temperature for the next lower operating mode for the first time (e.g. **Economy** with 59.0 °F (15.0 °C)) does the heating correspond to this operating mode.
- **Heating OFF at outdoor temperature** (Warm weather shut down WWSD): Use this menu option to set the outdoor temperature for the **Heating circuit 1** and/or **Heating circuit 2** at which the heating is to switch off:
 - **50 °F ... 77 °F (10 °C ...25 °C):** Outdoor temperature at which heating is turned off.
 - **210 °F (99 °C):** Function switched off, i. e. the heating can switch on at any outdoor temperature.
- **Risk of freezing at outdoor temperature:** Use this menu option to set the frost protection threshold temperature at which the heating for the **Heating circuit 1** and/or **Heating circuit 2** is to switch on:

If the outdoor temperature exceeds the set frost protection threshold temperature by 1.8 °F (1 °C) and there is no heat demand then the heating pump in the heating circuit switches off.

 - If the outdoor temperature does not exceed the frost protection threshold temperature then the heating pump in the heating circuit switches on (system frost protection).



WARNING: Domestic hot water pipework may freeze during longer periods of outdoor temperatures below 32 °F (0 °C), if the frost protection threshold is set too low.

- ▶ The frost protection threshold (37 °F (3 °C)) should only be adjusted by an installer.
- ▶ Do not set the frost protection level too low!
Damage caused by the frost protection threshold being set too low is not covered under warranty.

- **Mixer run time:** Use this menu option to set the **Mixer run time** to the runtime of the mixer motor used for **Heating circuit 1** and/or **Heating circuit 2**.

For menu structure and adjustment ranges
→ page 58.

8.4 Configuring the solar thermal system

For menu structure and adjustment ranges
→ page 60.



The heating system's solar thermal system has to be configured manually. The solar heating system will not be configured as part of the automatic configuration of the heating system (→ section 8.2, page 66).

Installer settings: Solar system config



A sample system can be found in section 2.5 on page 12. Other examples can be found in the instructions for the ISM or the planning documents.

Use this menu if you want to configure the solar heating system, e.g. at start-up or when changing the system.

- **Solar system:** Select installed solar basic system:
 - **1. Standard system:** Default system for solar hot water heating.
 - **2. Heating support:** Solar hot water heating with heating boost from a solar tank.
- **Solar sys option A 2 collector fields** for a second collector array (east/west orientation)
- **Solar sys option B Reloading system** for a solar recharge system (only in conjunction with **1. Standard system**)
- **Solar sys option C high/low priority** for a high/low priority system
- **Solar sys option D Ext heat exchanger** for an external heat exchanger
- **Solar sys option E Thermal disinfection** for thermal disinfection

8.5 Parameters for solar thermal system



Fill and bleed the solar thermal system according to its documentation and prepare it for commissioning as described this Section.

Installer settings: Solar sys parameters

The factory parameter settings on this menu are suitable for many common system dimensions. Use this menu if you want to finely adjust the parameters to suit the installed solar thermal system.



The specifications in parentheses are items that are also used in the wiring diagrams with system examples in the installation instructions of the ISM.

8.5.1 Commissioning the solar thermal system

Installer settings: Solar sys parameters

Before commissioning the solar thermal system you must:



- ▶ Fill and bleed the solar thermal system.
- ▶ Check the parameters for the solar thermal system and, if necessary, finely adjust them to suit the installed system.
- **Run solar system:** Use this menu option to commission the solar thermal system.
 - **Yes:** Solar thermal system is active. The ISM control outputs are enabled for automatic control purposes.
 - **No:** Solar thermal system is not active. The ISM control outputs are disabled for automatic control purposes but can be switched on manually.

For menu structure and adjustment ranges
→ page 62.

8.5.2 Resetting parameters for solar thermal system

Installer settings: Solar sys parameters

This function resets all settings on the **Solar sys parameters** and the **INSTALLER SETTINGS** to their factory settings. **Following such a reset, your installer will need to commission the system again!**

- ▶ Turn  until it points to the menu option **Reset factory settings**.
- ▶ Press .

The function **Reset factory settings** is selected and the option **No** is flashing.
- ▶ Turn  until the word **Yes** is flashing.

All solar system parameters were reset to default.

8.5.3 Parameters for the standard solar thermal system

Menu: Solar sys parameters > 1. Standard system

Use this menu to set the parameters for the solar thermal system if you are using it to provide domestic hot water.

- **SP: ON delta T:** Use this menu option to set the start temperature differential for the solar pump (SP).

If the difference between the collector temperature (T_1) and the solar tank temperature (T_2) rises above the set figure, the solar pump (SP) is switched on.
- **SP: OFF delta T:** Use this menu option to set the stop temperature differential for the solar pump (SP).

If the difference between the collector temperature (T_1) and the solar tank temperature (T_2) drops below the set figure, the solar pump (SP) is switched off.

- **T2: Max. solar tank temperature:** For a detailed description of **T2: Max. solar tank temperature** → page 50.
- **Maximum collector temperature:** Use this menu option to set the maximum temperature at the collector temperature sensor (T_1). If the temperature detected at the collector sensor (T_1) rises above the set figure, operation of the solar pump (SP) is disabled until the temperature drops back below the set figure.



At temperatures above 284 °F (140 °C) and system pressures < 58 PSI (< 4 bar), the heat transfer fluid in the collector evaporates. The solar pump remains disabled until the collector has cooled to a temperature at which there is no more vapor in the solar circuit.

- **SP: Collector field 1 pump mode:** Use this menu option to set the operating mode for the solar pump (SP).
 - **Auto:** Automatically controlled operation according to the set parameters.
 - **Manual ON:** Switches the pump permanently on (e.g. for bleeding the solar system when commissioning).
 - **Manual OFF:** Switches the pump permanently off (e.g. for servicing work on the solar system without having to interrupt heating operation).

For menu structure and adjustment ranges → page 61.

8.5.4 Parameters for solar heating boost system

Menu: Solar sys parameters > 2. Heating support

Use this menu to set the parameters for the solar thermal system if you are using it for a heating boost.

- **DWU1: ON delta T:** Use this menu option to set the start temperature differential for the valve for return temperature raising (DWU1). If the difference between the temperature in the solar tank (T_3) and the heating return temperature (T_4) exceeds the set value, the return temperature raising (DWU1) switches on.
- **DWU1: OFF delta T:** Use this menu option to set the stop temperature difference for the valve for return temperature raising (DWU1). If the difference between the temperature in the solar tank (T_3) and the heating return temperature (T_4) is less than the set value, the return temperature raising (DWU1) switches off.
- **DWU1: High return valve mode:** Use this menu option to select the operating mode of the valve for return temperature raising (DWU1).
 - **Auto:** Automatically controlled operation according to the set parameters.
 - **Manual ON:** The adjustment drive of the valve receives the switch signal and is opened or closed permanently depending on the construction of the valve (e.g. for function test).
 - **Manual OFF:** The adjustment drive of the valve receives no switch signal and remains opened or closed permanently depending on the construction of the valve (e.g. for function test).

- **DWU1: High return valve switch signal:** Use this menu option to switch the switch signal for the valve to return temperature raising (DWU1):
 - **Not reversed:** The switch signal remains unchanged.
 - **Reversed:** The switch signal for opening and closing is exchanged (e.g. in case of incorrect mounting of the DWU1).

For menu structure and adjustment ranges
→ page 61.

8.5.5 Parameters for the second collector field

Menu: Solar sys parameters > A collector field 2

Use this menu if you want to change the parameters for the second collector field (option A).

- **PA: ON delta T:** Use this menu option to set the start temperature differential for the solar pump on the second collector field (PA). If the difference between the collector temperature (TA) and the solar tank temperature (T₂) exceeds the set figure, the solar pump (PA) is switched on.
- **PA: OFF delta T:** Use this menu option to set the stop temperature differential for the solar pump on the second collector field (PA). If the difference between the collector temperature (TA) and the solar tank temperature (T₂) drops below the set figure, the solar pump (PA) is switched off.
- **PA: Collector field 2 pump mode:** Use this menu option to set the operating mode for the solar pump on the second collector field (PA).
 - **Auto:** Automatically controlled operation according to the set parameters.
 - **Manual ON:** Switches the pump permanently on (e.g. for bleeding the solar system when commissioning).
 - **Manual OFF:** Switches the pump permanently off (e.g. for servicing work on the solar system without having to interrupt heating operation).

For menu structure and adjustment ranges
→ page 61.

8.5.6 Parameters for the solar recharge system

Menu: Solar sys parameters > B Reload sys

Use this menu if you want to change the parameters for the solar recharge system.

- **PB: ON delta T:** Use this menu option to set the start temperature differential for the reload pump in the drinking water area (PB). If the difference between the measured temperature in the solar tank (T_2) and the temperature measured on the tank B (TB) exceeds the set value, the recharge pump in the drinking water area (PB) is switched on.
- **PB: OFF delta T:** Use this menu option to set the start temperature difference for the recharge pump in the drinking water area (PB). If the difference between the measured temperature in the solar tank (T_2) and the temperature measured on tank B (TB) drops below the set value, the recharge pump in the drinking water area (PB) is switched off.
- **TB: Max. temperature tank B:** For a detailed description of **TB: Max. temperature tank B** → page 50.
- **PB: DHW reload pump mode:** Use this menu option to set the operating mode for the recharge pump in the drinking water area (PB).
 - **Auto:** Automatically controlled operation according to the set parameters.
 - **Manual ON:** Switches the pump permanently on (e.g. for function test when commissioning).
 - **Manual OFF:** Switches the pump permanently off (e.g. for servicing work on the pump without having to interrupt heating operation).

For menu structure and adjustment ranges → page 61.

8.5.7 Parameters for a high/low priority system

Menu: Solar sys parameters > C High/low priority

- **High/low priority system type:** Use this menu option to select the configuration for the installed high/low priority system.
 - **Pump/Pump:** Solar tank is charged by solar pump (SP) and tank C by solar pump (PC).
 - **Pump/Valve:** Solar tank and tank C are charged by a solar pump (SP) and high/low priority valve (DWUC).

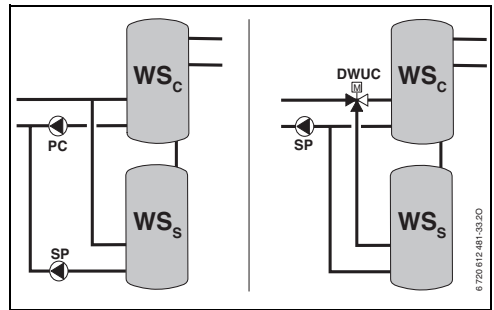

Fig. 26

- **TC: Max. temperature tank C:** For a detailed description of **TC: Max. temperature tank C** → page 50.
- **Priority tank:** Use this menu to select the priority tank.
 - **Solar tank:** Solar tank should be charged before tank C.
 - **Tank C:** Solar tank C should be charged before the solar tank.

- **Charge switchover test duration:** Use this menu option to set the test duration for recharge change of priority tank to the storage tank.
The solar pumps are, if the storage tank is being recharged, switched off at regular intervals (see **Charge switchover test interval**) for the set period. This way, the temperature in the collector increases and the required temperature difference for the recharging of the priority tank will be reached in this period if necessary.
- **Charge switchover test interval:** Use this menu option to set the test interval for recharge change of priority tank to the storage tank.
- **DWUC: HI/LO priority valve signal:** Use this menu option to switch the switch signal for the high/low priority valve (DWUC):
 - **Not reversed:** The switch signal remains unchanged.
 - **Reversed:** The switch signal for opening and closing is exchanged (e.g. in case of incorrect mounting of the DWUC).
- **PC: Solar pump mode:** Use this menu option to select the operating mode for the solar pump (PC).
 - **Auto:** Automatically controlled operation according to the set parameters.
 - **Manual ON:** Switches the pump permanently on (e.g. for bleeding the solar system when commissioning).
 - **Manual OFF:** Switches the pump permanently off (e.g. for servicing work on the solar system without having to interrupt heating operation).
- **DWUC: High/low priority valve mode:** Use this menu option to select the operating mode for the high/low priority valve (DWUC).
 - **Auto:** Automatically controlled operation according to the set parameters.
 - **Manual ON:** The adjustment drive of the valve receives the switch signal and is opened or closed permanently (e.g. for function test).
 - **Manual OFF:** The adjustment drive of the valve receives no switch signal and remains opened or closed permanently (e.g. for function test).

For menu structure and adjustment ranges
→ page 61.

8.5.8 Parameters for an external heat exchanger

Menu: Solar sys parameters > D Ext heat exchanger

Use this menu if you have an external heat exchanger on your solar system.

- **PD: ON delta T:** Use this menu option to set the start temperature difference for the secondary circuit pump (PD) between the external heat exchanger and the solar tank. If the difference between the measured temperature in the solar tank (T_2) and the temperature measured on the solar tank exceeds the set value, the secondary circuit pump (PD) is switched on.
- **PD: OFF delta T:** Use this menu option to set the stop temperature difference for the secondary circuit pump (PD) between the external heat exchanger and the solar tank. If the difference between the measured temperature in the solar tank (T_2) and the temperature measured on the solar tank drops below the set value, the secondary circuit pump (PD) is switched off.
- **PD: Secondary circuit pump mode:** Use this menu option to select the operating mode of the secondary circuit pump (PD) between the external heat exchanger and the solar tank:
 - **Auto:** Automatically controlled operation according to the set parameters.
 - **Manual ON:** Switches the pump permanently on (e.g. for function test when commissioning).
 - **Manual OFF:** Switches the pump permanently off (e.g. for servicing work on the pump without having to interrupt heating operation).

For menu structure and adjustment ranges
→ page 62.

8.5.9 Parameters for thermal disinfection

Menu: Solar sys parameters > E Therm disinfection

Use this menu if you want to thermally disinfect a tank (option E).

- **Solar tank thermal disinfection:** Use this menu option to switch the thermal disinfection of the solar tank on or off.
 - **Yes:** Thermal disinfection active The pump (PE) is activated using the settings on the menu **Thermal disinfection** (→ section 6.3.6 on page 48) and the entire tank volume is warmed up to the temperature required for thermal disinfection. During the thermal disinfection it is checked whether the required temperature for the thermal disinfection is reached at the bottom tank temperature sensor (T_2).
 - **No:** Thermal disinfection for the solar tank not active.
- **Thermal disinfection tank B:** Use this menu option to switch the thermal disinfection of the tank B on or off.
 - **Yes:** Thermal disinfection active The pump (PE) is activated using the settings on the menu **Thermal disinfection** (→ section 6.3.6 on page 48) and the entire tank volume is warmed up to the temperature required for thermal disinfection. During the thermal disinfection it is checked whether the required temperature for the thermal disinfection is reached at the top tank temperature sensor (TB).
 - **No:** Thermal disinfection for tank B not enabled.
- **Thermal disinfection tank C:** Use this menu option to switch the thermal disinfection of the tank C on or off.
 - **Yes:** Thermal disinfection active The pump (PE) is activated using the settings on the menu **Thermal disinfection** (→ section 6.3.6 on page 48) and the entire tank volume is warmed up to the temperature required for thermal disinfection. During the thermal disinfection it is checked whether the required temperature for the thermal disinfection is reached at the bottom tank temperature sensor (TC).
 - **No:** Thermal disinfection for tank C not enabled.
- **PE: Therm disinfect pump mode:** Use this menu option to select the operating mode of the pump (PE) for the thermal disinfection process.
 - **Auto:** Automatically controlled operation according to the set parameters.
 - **Manual ON:** Switches the pump permanently on (e.g. for function test when commissioning).
 - **Manual OFF:** Switches the pump permanently off (e.g. for servicing work on the pump without having to interrupt heating operation).

For menu structure and adjustment ranges
→ page 62.

8.5.10 Parameters for solar optimization

Solar optimization is performed automatically according to the available solar output.

Calculation of the solar output requires specification of the installed collector area, the collector type and the climate zone in which the system is installed.

Menu: Solar sys parameters > Solar optimization

Use this menu to set the parameters for solar optimization.

- **Collector field 1 area:** Use this menu option to set the installed collector area for collector field 1.

Collector type	Gross collector area in sq.ft. (m ²)
FKT-1	26 (2.4)
FKC-1	26 (2.4)
SKS 4.0	26 (2.4)
SKN 3.0	26 (2.4)

Tab. 8 Gross collector areas

- **Collector field 1 type:** Use this menu option to set the installed collector type for collector field 1.
- **Collector field 2 area:** Use this menu option to set the installed collector area for collector field 2 (OPTION A) → table 8
- **Collector field 2 type:** Use this menu option to set the installed collector type for collector field 2.
- **Climate zone:** Use this menu option to set the climate zone number for the geographical region in which the system is located.
 - Find the location of your system on the climate zones map (→ Fig. 27) and enter the climate zone number.

- If your location is not shown on the map, leave the number as it is (default setting is 90).

- **DHW optimization:** This parameter can also be set on the main menu under **Solar**. A detailed description can be found on page 51.
- **Heating circuit 1 optimization:** This parameter can also be set on the main menu under **Solar**. A detailed description can be found on page 51.
- **Heating circuit 2 optimization:** This parameter can also be set on the main menu under **Solar**. A detailed description can be found on page 51.

For menu structure and adjustment ranges → page 62.

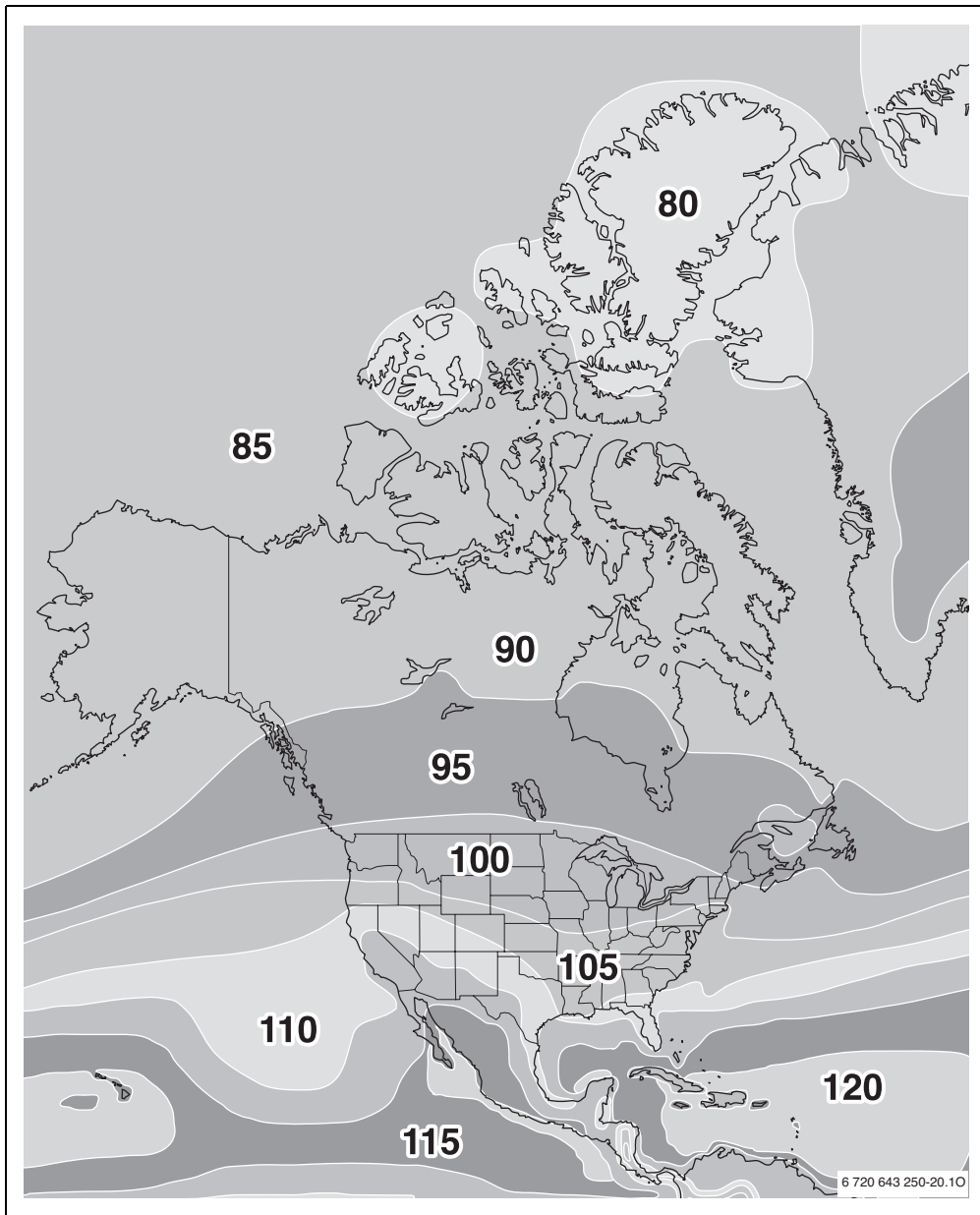

Fig. 27 Map of climate zones in North America

8.6 Fault history

Installer settings: Fault history

Installers can use this option to view the last 20 faults that have occurred on the system (fault date, source, code and description). The faults shown first may still be active.

Menu structure → page 63.

8.7 Viewing and entering the customer service address

Installer settings: Cust service address

- **Telephone number:** The installer can enter the phone number to call for customer service here.
- **Name:** The installer can enter the address of the technician responsible for customer service here.



To enter spaces:

- ▶ When the selected character is shown with a dark background, delete by pressing  (space = _)

For menu structure and adjustment range
→ page 63.

8.8 Viewing system information

Installer settings: System info

Shows a variety of system information:

- **Installation date** (automatically activated on commissioning)
- **Boiler part number** (fixed setting from boiler)
- **Boiler date of manufacture** (fixed setting from boiler)
- **Controller part number and model** (fixed factory setting)
- **Controller date of manufacture** (fixed factory setting)
- **Controller software version** (fixed factory setting)

Menu structure → page 64.

8.9 Slab drying function

Installer settings: Slab drying

The slab drying function allows fresh slab on radiant floor heating to be dried in accordance with the slab manufacturer's instructions. All mixed heating circuits are heated up equally.



WARNING: Risk of damaging or destroying the slab.

- ▶ With multi-circuit systems this function can be used in combination with a mixed heating circuit.
- ▶ Program slab drying function in accordance with slab manufacturer's instructions.
- ▶ In spite of the slab drying function, visit the system daily and make the prescribed reports.



DHW heating is not possible from programming to completing the slab drying function.

Menu: Slab drying

- **Cancel slab drying:** If the slab drying function is activated, the function can be switched off with **Yes**.
- **Maximum heating supply temperature:** Enter the maximum flow temperature (1) for the slab drying function here.
- **Maintain max heating supply temp for:** Enter the timescale (2) here of when the maximum supply temperature should be maintained.

• **Total slab drying time:**

- The minimum total duration (3) is automatically calculated by the heating controls. This is based on a rise of supply temperature of a maximum 18 °F (10 °C) per day.
- A higher value must be entered for the whole duration (3) if the slab cannot bear this increase. This produces a corresponding reduction in the daily increase.
- The first stage and the last stage of the supply temperature is 78 °F (25 °C) (fixed value).

Example:

Maximum supply temperature (1) =
122 °F (50 °C)

Duration of maximum supply temperature (2) =
7 days

Max. increase/decrease in temperature
per day = 9 °F (5 °C)

$$2d \times \frac{(122^{\circ}\text{F} - 77^{\circ}\text{F})}{9^{\circ}\text{F}} + 7d = 17d$$

$$2d \times \frac{(50^{\circ}\text{C} - 25^{\circ}\text{C})}{5\text{K}} + 7d = 17d$$

Total duration of slab drying (3) = 17 days

- **Start date:** Enter the start date of the slab drying here.
- **Start time:** Enter the start time of the slab drying here.

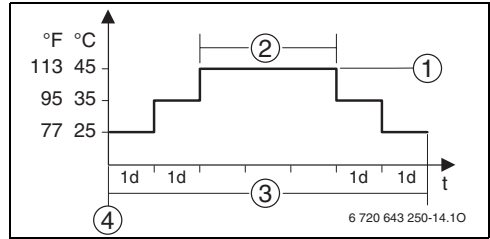

Fig. 28

- 1d** 1 day
- 1** Maximum supply temperature
- 2** Duration of max. supply temperature
- 3** Total duration of slab drying
- 4** Start date and start time
- t** Time
- VL** Supply temperature

For menu structure and adjustment range
→ page 65.

8.10 Test of the actuators on the system

INSTALLER SETTINGS: Output test

The **Output test** menu gives you the opportunity to activate individual actuators (pumps, mixing valves) individually to check their function.



As long as one or several actuators are activated manually, a corresponding message will be shown on the display.

-
- **Stop all output tests:** Use this parameter to reset the activation of all actuators to **Auto**.
 - **Pump, heating circuit 1:**
 - **Auto:** Control of the pump according to the set program
 - **Manual ON:** Pump always on
 - **Manual OFF:** Pump off
 - **Pump, heating circuit 2:** See above under **Pump, heating circuit 1**
 - **Mixer, heating circuit 1:**
 - **Auto:** Control of the mixing valve according to the set program
 - **Manual 100 % open:** Mixing valve in open position
 - **Manual 50 % open:** Mixing valve in middle position
 - **Manual 0 % open:** Mixing valve in closed position
- **Mixer, heating circuit 2:** See above under **Mixer, heating circuit 1**
 - **Tank charge pump:** See above under **Pump, heating circuit 1**
 - **DHW recirculation pump:** See above under **Pump, heating circuit 1**

For menu structure and adjustment range
→ page 65.

9 Troubleshooting

BUS device faults are indicated.

A boiler fault (e.g. EA fault) is shown in the controls display with the relevant advice.

- ▶ Notify your installer.



For the installer:

- ▶ Remove the fault in accordance with the details in the boiler documentation.

9.1 Troubleshooting with display

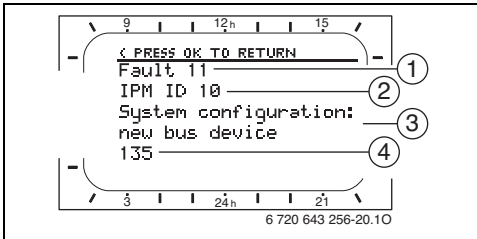

Fig. 29 Fault display

- 1** Fault number
- 2** BUS device that detected the fault and reported it to the controls
- 3** Description of fault
- 4** Code or additional information about fault

The current fault is indicated on the controls and on all remote controls:

- ▶ The relevant BUS device affected by the current fault must be determined. The fault can only be rectified on the BUS device from which the fault originates.

Display (→ Item 1, 3 and 4 in fig. 29)			
Text	Code	Cause	Remedy (by installer)
Fault 01 BUS communication fault.	10	BUS device assigned to the IPM FB 100 no longer answers.	Check BUS device, BUS connection and repair circuit break if necessary.
	200	Boiler no longer reporting.	
	201	Incorrect BUS device connected.	Identify and replace incorrect BUS device.
Fault 02 Internal fault	40	Incorrect BUS device connected.	Identify and replace incorrect BUS device.
	41	Two identical IDs set on IPM.	
	42	Code switch on IPM in intermediate position.	Switch system off and correct ID.
	50	Thermal disinfection via IPM failed.	Turn the supply temperature control on the boiler clockwise as far as it will go.
	100	ISM not responding.	Check BUS connection and repair circuit break if necessary.
	254	Overflow of fault messages.	–
Fault 02 Internal fault Some parameters reset to factory settings due to EEPROM fault!	205	See display text ¹⁾	Check parameter settings and readjust them as necessary. Identify defective controls and replace.
Fault 02 Internal fault FW200/FB100 can no longer control heating system.	255	See display text ¹⁾	Identify defective controls and replace.
Fault 03 Room temp sensor defective	20	There is a circuit break on the room temperature sensor built into the FW 200/FB 100.	Identify defective controls or remote control and replace.
	21	There is a short circuit on the room temperature sensor built into the FW 200/FB 100.	
Fault 10 System configuration: invalid Remote control detected or set for non-existent heating circuit. Check ID.	194	See display text ¹⁾	Check system layout, check system configuration, modify if necessary.
	195		
Fault 10 System configuration: invalid Only one unmixed heating circuit permitted in FW200 system.	196		
	197		
	198		
	199		

1) The display text is shown on the BUS device (e.g. remote control) that detected the fault. On the other BUS devices, instead of this, the code is displayed and corresponds to the display test.

Display (→ Item 1, 3 and 4 in fig. 29)				
Text	Code	Cause	Remedy (by installer)	
Fault 11 System configuration: new bus device New ISM detected. Power up all ISMs simultaneously and start automatic system configuration.	131 132	See display text ¹⁾		
Fault 11 System configuration: new bus device New remote control detected. Check and modify system configuration.	133 134			
Fault 11 System configuration: new bus device New IPM detected. Check and modify system configuration.	135 136 137 138 139			
Fault 12 System configuration: bus device missing ISM2 not detected. Check connection.	170 171			
Fault 12 System configuration: bus device missing Previously present IPM for tank downstream of low loss header not detected. Check ID.	172			Check and correct ID. For IPM when de-energized.
Fault 12 System configuration: bus device missing IPM for tank downstream of low loss header not detected. Check connection and ID.	173			See display text ¹⁾
Fault 12 System configuration: bus device missing Remote control with ID 1 not detected. Check connection and ID.	174 175	See display text ¹⁾		
Fault 12 System configuration: bus device missing IPM with ID 1 not detected. Check connection and ID.	176 177 178 179	See display text ¹⁾		

1) The display text is shown on the BUS device (e.g. remote control) that detected the fault. On the other BUS devices, instead of this, the code is displayed and corresponds to the display test.

Display (→ Item 1, 3 and 4 in fig. 29)			
Text	Code	Cause	Remedy (by installer)
Fault 13 System configuration: bus device changed or replaced Check system configuration for DHW or start automatic system configuration.	157	See display text ¹⁾	
Fault 13 System configuration: bus device changed or replaced Check system configuration for heating circuit x and connections on IPM for heating circuit x.	158 159	See display text ¹⁾	
Fault 14 System configuration: incompatible bus device DHW is controlled by boiler. IPM control of DHW is disabled.	117	See display text ¹⁾	Identify incompatible BUS device and remove from the system.
Fault 14 System configuration: incompatible bus device IPM for tank must be set to ID 3 or higher.	118 119	See display text ¹⁾	
Fault 15 outdoor temperature sensor not connected Outdoor temperature not available.	30	See display text ¹⁾	Check outdoor temperature sensor and remedy interruption, if necessary.
Fault 19 Unable to save parameter settings	202	BUS device is configured but not available at present.	Check system layout, check system configuration, modify if necessary and set parameter again.
Fault 20 System configuration: invalid	192	Invalid ID in remote control for the heating circuit.	In combination with FW 200 only ID 1 to 4 is possible in the remote control.
Fault 21 System configuration: new bus device	135 137 139	See display text in the remote control	
Fault 22 System configuration: bus device missing	178 179	IPM with ID x not detected on the remote control.	Check connection and ID of the IPM and adapt if necessary.
Fault 23 System configuration: bus device changed or replaced	159	System configuration for heating circuit x and connections on IPM for heating circuit x not permitted.	Check system configuration for heating circuit x and connections on IPM for heating circuit x.

1) The display text is shown on the BUS device (e.g. remote control) that detected the fault. On the other BUS devices, instead of this, the code is displayed and corresponds to the display test.

Display (→ Item 1, 3 and 4 in fig. 29)			
Text	Code	Cause	Remedy (by installer)
Fault 24 System configuration: incompatible bus device	119	See display text in the remote control	
Fault 28 Remote control is installed in boiler	155	Remote control installed in boiler.	Mount remote control in living area.
Fault 29 Unable to save parameter settings	202	BUS device is configured but not available at present.	Check system structure, check system configuration, adjust as necessary and reset parameters on remote control.
Fault 30 Mixer temperature sensor defective	7	Mixer temperature sensor (MF) connected to IPM defective.	Check mixer temperature sensor (MF) and replace if necessary.
Fault 31 External heating supply temperature sensor defective	6	Common temperature sensor (VF) connected to IPM defective.	Check common temperature sensor (VF) and replace if necessary.
Fault 32 Tank temperature sensor defective	8	Tank temperature sensor (SF) connected to IPM defective.	Check storage tank temperature sensor (SF) and replace if required.
Fault 33 Temperature sensors incorrectly connected	20	A storage tank temperature sensor (SF) and mixer temperature sensor (MF) are connected to the IPM.	Remove one of the two temperature sensors (SF or MF).
	21	Two common temperature sensors (VF) are connected to the IPM.	Remove one common temperature sensor (VF).
Fault 34 Connected sensors and mode of operation do not match.	23	Temperature sensors connected to the IPM and assigned operating mode do not match.	Check the temperature sensors and assigned operating mode and adapt if necessary.
Fault 40 Temperature sensor T1 on collector field 1 defective	101	Short circuit on the sensor lead (T ₁).	Check temperature sensor (T ₁) and replace if necessary.
	102	Break in sensor lead (T ₁).	
Fault 41 Temperature sensor T2 at bottom of solar tank defective	103	Short circuit on the sensor lead (T ₂).	Check temperature sensor (T ₂) and replace if necessary.
	104	Break in sensor lead (T ₂).	
Fault 42 Temperature sensor T3 on tank at heating return defective	105	Short circuit on the sensor lead (T ₃).	Check temperature sensor (T ₃) and replace if necessary.
	106	Break in sensor lead (T ₃).	
Fault 43 Temperature sensor T4 at heating return defective	107	Short circuit on the sensor lead (T ₄).	Check temperature sensor (T ₄) and replace if necessary.
	108	Break in sensor lead (T ₄).	

Display (→ Item 1, 3 and 4 in fig. 29)			
Text	Code	Cause	Remedy (by installer)
Fault 44 Temperature sensor T5 at top of solar tank defective	109	Short circuit on the sensor lead (T ₅).	Check temperature sensor (T ₅) and replace if necessary.
	110	Break in sensor lead (T ₅).	
Fault 45 Temperature sensor T6 at bottom of supplementary tank defective	111	Short circuit on the sensor lead (T ₆).	Check temperature sensor (T ₆) and replace if necessary.
	112	Break in sensor lead (T ₆).	
Fault 46 Temperature sensor TA on collector field 2 defective	113	Short circuit on the sensor lead (TA).	Check temperature sensor (TA) and replace if necessary.
	114	Break in sensor lead (TA).	
Fault 47 Temperature sensor TB at top of tank B defective	115	Short circuit on the sensor lead (TB).	Check temperature sensor (TB) and replace if necessary.
	116	Break in sensor lead (TB).	
Fault 48 Temperature sensor TC at bottom of tank C defective	117	Short circuit on the sensor lead (TC).	Check temperature sensor (TC) and replace if necessary.
	118	Break in sensor lead (TC).	
Fault 49 Temperature sensor TD on external heat exchanger defective	119	Short circuit on the sensor lead (TD).	Check temperature sensor (TD) and replace if necessary.
	120	Break in sensor lead (TD).	
Fault 50 Solar pump seized or air in system	121	Solar pump (SP, PA or PC) sticking due to physical blockage.	Unscrew and remove the slotted screw on the pump head and use a screwdriver to release the pump shaft. Do NOT strike the pump shaft with the screwdriver.
	126		
	140		
		Air in solar thermal system.	Bleed solar system and top up with heat transfer fluid if necessary.
	143	Secondary circuit pump (PD) sticking due to physical blockage.	Unscrew and remove the slotted screw on the pump head and use a screwdriver to release the pump shaft. Do NOT strike the pump shaft with the screwdriver.

Display (→ Item 1, 3 and 4 in fig. 29)			
Text	Code	Cause	Remedy (by installer)
Fault 51 Incorrect temperature sensor type connected	122	Collector temperature sensor type used as tank temperature sensor (T_2).	Use correct type of temperature sensor. → Technical data in ISM installation instructions.
	123	Tank temperature sensor type used as collector temperature sensor (T_1).	
	127	Tank temperature sensor type used as collector temperature sensor (TA).	
	132	Temperature sensor type PTC 1000 used as tank temperature sensor (T_2).	
	133	Temperature sensor type PTC 1000 used as collector temperature sensor (T_1).	
Fault 52 Temperature sensors reversed	124	Temperature sensors (T_1 and T_2) reversed.	Check the temperature sensors and swap the connections if necessary.
	129	Temperature sensors (TA and T_2) reversed.	
	130	Temperature sensors (T_1 and TA) reversed.	
	131	Temperature sensors (T_2 and TB) reversed.	
	141	Temperature sensors (T_2 and TC) reversed.	
	144	Temperature sensors (T_2 and TD) reversed.	
Fault 53 Temperature sensor installed in wrong location	125	Collector temperature sensor (T_1 or TA) installed on collector field inlet.	Mount collector temperature sensor (T_1 or TA) close to collector field outlet.
	128		
Fault 54 Temperature for thermal disinfection not reached in solar tank	145	Maximum temperature for solar tank too low.	Set higher maximum temperature for solar tank.
		Delivery rate of disinfection pump (PE) too low.	Set higher pump speed on disinfection pump (PE) or, if possible, open flow restrictor more.
		Thermal disinfection cancelled manually before the required temperature was reached in the solar tank.	No fault. Message is shown only for 5 minutes.

Display (→ Item 1, 3 and 4 in fig. 29)			
Text	Code	Cause	Remedy (by installer)
Fault 55 Solar system not yet commissioned	146	Solar system is not yet in operation.	Fill, bleed and prepare the solar thermal system for commissioning according to its documentation. Then start up the solar system.
Fault 56 At least one pump/valve in manual mode	147	Pump (SP) in manual mode.	Reset parameters for pump or valve to "Auto".
	148	Valve (DWU1) in manual mode.	
	150	Pump (PA) in manual mode.	
	151	Pump (PB) in manual mode.	
	152	Pump/valve (PC/DWUC) in manual mode.	
	153	Pump (PD) in manual mode.	
	154	Pump (PE) operated manually.	
Fault 59 Flow rate in solar system too high/low.	201	Flow rate in solar system for collector field 1 is too high.	Set flow rate in solar circuit correctly (e.g. increase/reduce pump speed) or, if necessary, further open or close flow setter on the solar pump station. Target: 0.22 gpm (50 l/h) of collector. Check that the settings match the collector area, type and location factor in the solar optimization menu.
	202	Flow rate in solar system for collector field 1 is too low.	
	203	Flow rate in solar system for collector field 2 is too high.	
	204	Flow rate in solar system for collector field 2 is too low.	

9.2 Troubleshooting without using display

Problem	Cause	Remedy
Required room temperature not achieved.	Thermostatic valve(s) set too low.	Set thermostatic valve(s) higher.
	Heating curve set too low.	“Heating levels” for “Comfort” or arrange for installer to correct heating curve.
	Supply temperature controller on the boiler set too low.	Set the supply temperature controller higher. Reduce influence of solar optimization if necessary.
	Air in the heating system.	Bleed radiators and vent the heating system.
Heat-up takes too long	“Heat-up speed” set too low.	Set “Heat-up speed” e. g. to “Fast”.
Required room temperature greatly exceeded.	Radiators become too hot.	Set thermostatic valve(s) lower. “Heating levels” for “Comfort” or arrange for installer to correct heating curve.
	Installation site of FW 200 unfavorable, e.g. external wall, close to window, in a draft, ...	Select a better location for FW 200 and ask your installer to reposition it.
Excessive room temperature fluctuations.	Temporary influence of external heat on the room, e.g. through solar radiation, lighting, TV, fireplace etc.	Arrange for installer to increase “Room influence”.
		Select a better location for FW 200 and ask your installer to reposition it.
	Mixer time set incorrectly.	Have mixer time set by the installer according to the technical data for the mixer.
Temperature rises instead of falling.	Clock time incorrectly set.	Check time setting.
Room temperature too high during “Economy” and/or “Frost” mode.	The building retains a lot of heat.	Set an earlier switching time for “Economy” and/or “Frost”.
Incorrect or no control.	BUS connection or BUS device defective.	Ask your installer actor to check the BUS connection against the wiring diagram and correct it if required.
Controls can only be set to automatic mode.	Mode selector defective.	Have FW 200 replaced by your installer.
Domestic hot water tank does not heat up.	Hot water temperature control on boiler set too low.	Set hot water temperature control higher. Reduce influence of solar optimization if necessary.
	Supply temperature controller on the boiler set too low.	Turn the supply temperature control on the boiler clockwise as far as it will go.

If the fault persists:

- ▶ Call the authorized installer or customer service and inform them of the fault, quoting the controls details (from the identification plate inside the flap).

Appliance details

Type:.....

Order number:.....

Date of manufacture (FD...):

10 Energy saving tips

- With outdoor reset controls, the supply temperature is controlled in accordance with the set heating curve: The colder the outdoor temperature the higher the supply temperature.

Save energy: Set the heating curve as low as possible in accordance with the building's insulation and the system conditions (→ section 8.3 from page 67).

- Radiant floor heating:
Do not set the supply temperature higher than the maximum supply temperature recommended by the manufacturer (e.g. 140 °F (60 °C)).
- Make effective use of the temperature levels and switch points by setting them to suit the preferences of the occupants.
 - **Comfort** ☀ = Comfortable living environment
 - **Economy** ☾ = Active living environment
 - **Frost** ❄ = Away from home or asleep.
- Set the thermostat valves in all rooms so that the required room temperatures can be achieved. Only increase the temperature levels if the temperature has not reached after some time (→ section 6.2.2 on page 41).
- Much energy can be saved by reducing the room temperature via economy phases: Reducing the room temperature by 1.8 °F (1 °C): up to 5% energy can be saved.
Not recommended: To let the room temperature fall below 60 °F (+15 °C) during the daytime, otherwise the cooler walls continue to radiate cold, the boiler works harder to raise the rooms to the desired temperature, leading to higher energy consumption than if a constant heat supply had been applied.
- With well insulated buildings it can be the case that the room temperature remains

above the temperature set for **Economy**. Nevertheless energy is being saved as the heating system stays off. In this case, you can set the switch point for **Economy** earlier.

- Don't keep windows cracked for ventilation. This way, heat is always drawn out of the room without noticeably improving the room air.
- Vent briefly but intensively (open window fully).
- When ventilating, turn off the thermostatic valve or set the mode selector to **Frost**.
- Make effective use of the temperature levels and switch points for the hot water by setting them to suit the preferences of the occupants.

Solar optimization

Activate the **DHW optimization** by setting a value between 1.8 °F to 36 °F (1 °C to 20 °C) (→ section 6.5 on page 50).

If the influence of the **DHW optimization** is too great, reduce the setting a small amount at a time.

Activate the **Heating circuit optimization** by setting a value between 1.8 °F to 9 °F (1 °C to 5 °C) (→ section 6.5 on page 50).

If the influence of the **Heating circuit optimization** is too great, reduce the setting a small amount at a time.

11 Environmental protection

Environmental protection is one of the fundamental company policies of the Bosch Group.

We regard quality of performance, economy and environmental protection as equal objectives.

Environmental protection laws and regulations are strictly adhered to.

To protect the environment, we use the best possible technology and materials taking into account economic points of view.

Packaging

For the packaging, we participate in the country-specific recycling systems, which guarantee optimal recycling.

All packaging materials used are environmentally-friendly and recyclable.

Old appliances

Old appliances contain resources that must be submitted for recycling.

The components are easy to separate and the plastics are marked. This allows the various components to be sorted for appropriate recycling or disposal.

12 Commissioning log for the heating system

Home owner/operator:	System installer:
Date commissioned:	FD (Date of manufacture):
Number of heating circuits: 1: <input type="checkbox"/> mixed/ <input type="checkbox"/> unmixed, FB100 <input type="checkbox"/> <input type="checkbox"/> Mixer time _____ sec set. 2: <input type="checkbox"/> mixed/ <input type="checkbox"/> unmixed, FB100 <input type="checkbox"/> <input type="checkbox"/> Mixer time _____ sec set. 3: <input type="checkbox"/> mixed/ <input type="checkbox"/> unmixed, FB100 <input type="checkbox"/> <input type="checkbox"/> Mixer time _____ sec set. 4: <input type="checkbox"/> mixed/ <input type="checkbox"/> unmixed, FB100 <input type="checkbox"/> <input type="checkbox"/> Mixer time _____ sec set.	System for DHW heating: <input type="checkbox"/> Combi boiler <input type="checkbox"/> Tank on boiler <input type="checkbox"/> tank on low-loss header
	IPM module: ID 3 <input type="checkbox"/> ID 4 <input type="checkbox"/> ID 5 <input type="checkbox"/> ID 6 <input type="checkbox"/> ID 7 <input type="checkbox"/> ID 8 <input type="checkbox"/> ID 9 <input type="checkbox"/> ID 10 <input type="checkbox"/>
	Solar heating system: Basic solar heating system: 1 <input type="checkbox"/> , 2 <input type="checkbox"/> Solar options: A <input type="checkbox"/> , B <input type="checkbox"/> , C <input type="checkbox"/> , D <input type="checkbox"/> , E <input type="checkbox"/>
The following work has been carried out:	
<input type="checkbox"/> System hydraulics checked; Comments:	
<input type="checkbox"/> Electrical connection checked; Comments:	
<input type="checkbox"/> Automatic configuration completed; Comments:	
<input type="checkbox"/> Heating circuits (IPM) configured; Comments:	
<input type="checkbox"/> Domestic hot water system configured; Comments:	
<input type="checkbox"/> Solar heating system configured and put into service; Comments:	
<input type="checkbox"/> Function check carried out	
<input type="checkbox"/> Customer/system user has been trained how to use the controls	
<input type="checkbox"/> Device documentation handed over	
Date and signature of system installer:	





























































13 Individual timer program settings

The default settings and personal settings for the timer programs are summarized below.

13.1 Heating program for the heating circuit 1 and heating circuit 2

































































Setting the heating program is described in section 6.2 on page 39.

Ready-made heating programs (for copying)

	P1		P2		P3		P4		P5		P6	
	  		  		  		  		  		  	
AM weekday worker												
Monday - Thursday		06:00am		08:00am		12:00pm		10:00pm	-	-	-	-
Friday		06:00am		08:00am		12:00pm		11:30pm	-	-	-	-
Saturday		07:00am		11:30pm	-	-	-	-	-	-	-	-
Sunday		08:00am		10:00pm	-	-	-	-	-	-	-	-
PM weekday worker												
Monday - Thursday		07:00am		12:00pm		05:00 m		10:00pm	-	-	-	-
Friday		07:00am		12:00pm		05:00pm		11:30pm	-	-	-	-
Saturday		07:00am		11:30pm	-	-	-	-	-	-	-	-
Sunday		08:00am		10:00pm	-	-	-	-	-	-	-	-
All day												
Monday - Thursday		06:00am		08:00am		05:00pm		10:00pm	-	-	-	-
Friday		06:00am		08:00am		05:00pm		11:30pm	-	-	-	-
Saturday		07:00am		11:30pm	-	-	-	-	-	-	-	-
Sunday		08:00am		10:00pm	-	-	-	-	-	-	-	-

























	P1		P2		P3		P4		P5		P6	
All day, lunch												
Monday - Thursday		06:00am		08:00am		12:00pm		1:00pm		05:00pm		10:00pm
Friday		06:00am		08:00am		12:00pm		1:00pm		05:00pm		11:30pm
Saturday		07:00am		11:30pm	-	-	-	-	-	-	-	-
Sunday		08:00am		10:00pm	-	-	-	-	-	-	-	-
Family (Factory settings)												
Monday - Thursday		06:00am		10:00pm	-	-	-	-	-	-	-	-
Friday		06:00am		11:30pm	-	-	-	-	-	-	-	-
Saturday		07:00am		11:30pm	-	-	-	-	-	-	-	-
Sunday		08:00am		10:00am	-	-	-	-	-	-	-	-
All day, early shift												
Monday - Thursday		04:00am		10:00pm	-	-	-	-	-	-	-	-
Friday		04:00am		11:00pm	-	-	-	-	-	-	-	-
Saturday		07:00am		11:00pm	-	-	-	-	-	-	-	-
Sunday		07:00am		10:00pm	-	-	-	-	-	-	-	-
All day, late shift												
Monday - Thursday		06:00am		11:30pm	-	-	-	-	-	-	-	-
Friday		06:00am		11:30pm	-	-	-	-	-	-	-	-
Saturday		07:00am		11:30pm	-	-	-	-	-	-	-	-
Sunday		08:00am		11:30pm	-	-	-	-	-	-	-	-
Seniors												
Monday - Thursday		07:00am		11:00pm	-	-	-	-	-	-	-	-
Friday		07:00am		11:00pm	-	-	-	-	-	-	-	-
Saturday		07:00am		11:00pm	-	-	-	-	-	-	-	-
Sunday		07:00am		11:00pm	-	-	-	-	-	-	-	-













Ready-made heating programs in program locations A to F (can be modified)

	P1		P2		P3		P4		P5		P6	
	  		  		  		  		  		  	
Program A												
All days												
Mon - Fri												
Sat + Sun												
Monday		06:00am		10:00pm								
Tuesday		06:00am		10:00pm								
Wednesday		06:00am		10:00pm								
Thursday		06:00am		10:00pm								
Friday		06:00am		11:30pm								
Saturday		07:00am		11:30pm								
Sunday		08:00am		10:00pm								
Program B												
All days												
Mon - Fri												
Sat + Sun												
Monday		06:00am		08:00am		05:00pm		10:00pm				
Tuesday		06:00am		08:00am		05:00pm		10:00pm				
Wednesday		06:00am		08:00am		05:00pm		10:00pm				
Thursday		06:00am		08:00am		05:00pm		10:00pm				
Friday		06:00am		08:00am		05:00pm		11:30pm				
Saturday		07:00am		11:30pm								
Sunday		08:00am		10:00pm								
Program C												
All days		07:00am		11:00pm								
Mon - Fri												
Sat + Sun												
Monday												
Tuesday												
Wednesday												
Thursday												
Friday												
Saturday												
Sunday												

	P1		P2		P3		P4		P5		P6	
Program D												
All days												
Mon - Fri												
Sat + Sun												
Monday		06:00am		10:00pm								
Tuesday		06:00am		10:00pm								
Wednesday		06:00am		10:00pm								
Thursday		06:00am		10:00pm								
Friday		06:00am		11:30pm								
Saturday		07:00am		11:30pm								
Sunday		08:00am		10:00pm								
Program E												
All days												
Mon - Fri												
Sat + Sun												
Monday		06:00am		08:00am		05:00pm		10:00pm				
Tuesday		06:00am		08:00am		05:00pm		10:00pm				
Wednesday		06:00am		08:00am		05:00pm		10:00pm				
Thursday		06:00am		08:00am		05:00pm		10:00pm				
Friday		06:00am		08:00am		05:00pm		11:30pm				
Saturday		07:00am		11:30pm								
Sunday		08:00am		10:00pm								
Program F												
All days		07:00am		11:00pm								
Mon - Fri												
Sat + Sun												
Monday												
Tuesday												
Wednesday												
Thursday												
Friday												
Saturday												
Sunday												







Own settings

		P1	P2	P3	P4	P5	P6					
	  		  		  		  		  		  	
Program position A, Name: _____, assigned to heating circuit: ____												
All days												
Mon - Fri												
Sat + Sun												
Monday												
Tuesday												
Wednesday												
Thursday												
Friday												
Saturday												
Sunday												
Program position B, Name: _____, assigned to heating circuit: ____												
All days												
Mon - Fri												
Sat + Sun												
Monday												
Tuesday												
Wednesday												
Thursday												
Friday												
Saturday												
Sunday												
Program position C, Name: _____, assigned to heating circuit: ____												
All days												
Mon - Fri												
Sat + Sun												
Monday												
Tuesday												
Wednesday												
Thursday												
Friday												
Saturday												
Sunday												

	P1		P2		P3		P4		P5		P6	
												
Program position D, Name: _____, assigned to heating circuit: ____												
All days												
Mon - Fri												
Sat + Sun												
Monday												
Tuesday												
Wednesday												
Thursday												
Friday												
Saturday												
Sunday												
Program position E, Name: _____, assigned to heating circuit: ____												
All days												
Mon - Fri												
Sat + Sun												
Monday												
Tuesday												
Wednesday												
Thursday												
Friday												
Saturday												
Sunday												
Program position F, Name: _____, assigned to heating circuit: ____												
All days												
Mon - Fri												
Sat + Sun												
Monday												
Tuesday												
Wednesday												
Thursday												
Friday												
Saturday												
Sunday												

13.2 DHW program





How to set the DHW program is described in Section 6.3 on page 42.

	P1		P2		P3		P4		P5		P6	
	°F/ °C ¹⁾		°F/ °C ¹⁾		°F/ °C ¹⁾		°F/ °C ¹⁾		°F/ °C ¹⁾		°F/ °C ¹⁾	
Factory settings												
Monday - Thursday	140 °F /On	05:00am	59 °F /Off	11:00pm	-	-	-	-	-	-	-	-
Friday	140 °F /On	05:00am	59 °F /Off	11:00pm	-	-	-	-	-	-	-	-
Saturday	140 °F /On	06:00am	59 °F /Off	11:00pm	-	-	-	-	-	-	-	-
Sunday	140 °F /On	07:00am	59 °F /Off	11:00pm	-	-	-	-	-	-	-	-
Personal setting for Domestic hot water												
All days												
Mon - Fri												
Sat + Sun												
Monday												
Tuesday												
Wednesday												
Thursday												
Friday												
Saturday												
Sunday												

1) Temperature level with tank, On/Off with combi boiler

13.3 DHW circulation program

How to set the hot water circulation program is described in Section 6.3 on page 42.

	P1		P2		P3		P4		P5		P6	
	On/ Off		On/ Off		On/ Off		On/ Off		On/ Off		On/ Off	
Factory settings												
Monday - Thursday	On	06:00am	Off	11:00pm	-	-	-	-	-	-	-	-
Friday	On	06:00am	Off	11:00pm	-	-	-	-	-	-	-	-
Saturday	On	07:00am	Off	11:00pm	-	-	-	-	-	-	-	-
Sunday	On	08:00am	Off	11:00pm	-	-	-	-	-	-	-	-
Personal setting												
All days												
Mon - Fri												
Sat + Sun												
Monday												
Tuesday												
Wednesday												
Thursday												
Friday												
Saturday												
Sunday												

Index

A

Accessories	11, 18
Adjust internal room sensor	67
Automatic system configuration	20, 66

B

Base point heating curve	69
Basic display	49
Being away from home	28
Boiler	
- Equipment	9
- Fault	86
- Settings	39, 42, 67
BUS devices	66
BUS leads	19
BUS subscribers	86
Button	3

C

Change heating program	39–40, 44–46
Changing operating mode	28
Changing room temperature	30, 41
Cleaning	10
Climate zone	80
Coding of BUS devices	66
Colder	
- Heating	30, 39–40, 44–46
Collector area	80
Comfort	39
Commissioning (installers only)	20
Commissioning log	98
Contrast	49
Controller messages	86
Controls	3
Convectors	68–69
Cooler	
- Domestic hot water	42
Customer service address	63, 82

D

Default settings	26, 58, 73
Design temperature	70
Details about the device	
- Scope of delivery	9
- Technical specifications	10
DHW recirculation pump CP	13
DHW recirculation pump for thermal disinfection P _E	13
Dial	3
Dimensions	15
Display	
- Basic display	49
- Contrast	49
Display formats	49
Disposal	18, 97
Domestic hot water circulation	46
Domestic hot water program	35, 42
DWU1	13, 74–75
DWUC	13, 77

E

Electrical connections	
- Connecting BUS devices	19
End point heating curve	69
Energy saving	96
Environmental protection	97
External heat exchanger	78

F

Factory settings	26, 32, 52, 58
Fault history	63
Fault indication	86
Faults	63, 82, 86
- Boiler	86
Frost protection threshold temperature	71

G

General settings	37, 49
------------------------	--------

H

Heating boost	72, 74
Heating circuit	
- Mixed	47, 83
- Unmixed	47
Heating circuit without mixer	47
Heating curve	68–69
Heating curve base point	68, 70
Heating curve end point	68, 70
Heating off at outdoor temperature	71
Heating off at outdoor temperature of	70
Heating off at too low temperature level	71
Heating program	33, 39
Heating rate	41
Heating type in heating circuit	68
Heating zone	
- Mixed	13
High/low priority system	13, 72, 76
Higher	
- Heating	39, 41
Highlight	13
Hotter	
- Domestic hot water	42

I

Individual timer programs (table)	99
Info	52
Information about these instructions	6
Information on the basic display	49
Initial test	85
Installation	14
- Accessories	18
- FW 200 in boiler	14
- FW 200 to wall	15
- Outdoor temperature sensor	17
Installer settings	57
- Configuring solar system	60, 72
- Customer service address	63, 82
- Fault history	63
- Heating parameters	59, 67
- Output test	65
- Slab drying	65, 83
- Solar system parameters	61, 73
- System configuration	58, 66
- System faults	82
- System info	64, 83

K

Key lock	49
----------------	----

L

Leaving the apartment	28
Leaving the house	28
Location	
- FW 200	15
Lower	
- Heating	39, 41

M

Main menu	
- Domestic hot water	35, 42
- General settings	37, 49
- Heating	33, 39
- Solar	38, 50
- Vacation	28, 32
Making the electrical connections	19
Menu	
- Info	52
- Installer settings	57
Configuring solar system	60, 72
Customer service address	63, 82
Fault history	63
Heating parameters	59, 67
Output test	65
Slab drying	65, 83
Solar system parameters	61, 73
System configuration	58, 66
System faults	82
System info	64, 83
- Main menu	
Domestic hot water	35, 42
General settings	37, 49
Heating	33, 39
Solar	38, 50
Vacation	28, 32
Menu structure	32, 52, 58
Mixed heating circuit	47, 83
Mixed heating zone	13
Mixer running time	71
Mounting	
- Accessories	18
- FW 200 in boiler	14
- FW 200 to wall	15
- Outdoor temperature sensor	17
N	
Night-time operation (economy)	41

- O**
- Old appliances97
 - Operation21
 - Changing hot water mode28
 - Changing room temperature30, 41
 - Changing the operating mode for heating ..28
 - Setting heating temperature41
 - Option
 - A: 2nd collector field13, 72
 - B: Charging system72
 - C: high/low priority system13, 72
 - D: External heat exchanger in the solar circuit72
 - E: Thermal disinfection of the solar tank13, 72
 - Outdoor temperature96
 - Outdoor temperature sensor17
- P**
- Packaging18, 97
 - Panel radiator96
 - Performance15, 17
 - Power failure9
 - Power module IPM 2 (accessory)13
 - Power reserve9
 - Priority tank76
 - Programming
 - Installer settings57
 - Resetting to default settings
 - All settings26
 - Set fast heat-up41
 - Set heating program39–40, 44–46
 - Setting domestic hot water program42
 - Setting heating program39
 - Setting language49
 - Setting the date49
 - Setting the time49
 - Setting timer program for hot water recirculation pump46
 - Setting vacation program28
 - Specifying the heating curve68
 - Pump - Pump76
 - Pump - Valve76
- R**
- Radiant floor heating 68–69, 83, 96
 - Radiators 68–69
 - Recharge system 76
 - Recycling 97
 - Reset
 - All settings 26
 - Resetting settings 26
 - Reuse 97
 - Room influence 70
- S**
- Safety instructions 8
 - Scope of delivery 9
 - Segment 43, 46
 - Circulation program 46
 - On/off 46
 - Hot water program 43
 - Individual temperature levels 43
 - On/off (combi boiler) 43
 - Set heating start 39–40, 44–46
 - Set increased/decreased heating level 39–40, 44–46
 - Set slab drying 83
 - Setting constant economy 27
 - Setting constant Frost protection 27
 - Setting constant heating 27
 - Setting economy mode 27
 - Setting Frost protection mode 27
 - Setting heating higher/lower 39
 - Setting heating mode 27
 - Setting heating start time 39
 - Setting heating temperature 41
 - Setting language 49
 - Setting the date 49
 - Setting the heating curve 68
 - Setting the time 49
 - Setting up automatic mode 27
 - Solar circuit pump
 - PA 13
 - SP 13
 - Solar module for heating boost ISM 2 (accessory) 13

Solar optimization	51
Solar program	38, 50
Solar pump	
- PC	77
- SP	73–75
Solar radiation	94
Solar standard system	72
Standard solar system	73
Symbols	3
System configuration	58
- Automatic	20
System configuration (automatic)	66
System faults	82
System type of the high/low priority system ...	76

T

Technical specifications	10
Test	
- Actuators	85
- Outputs for pumps and mixer	85
Thermal disinfection	29, 48, 79
Thermostatic valves	96
Time adjustment	49
Timer programs	22, 39, 99
Times for hot water	42
Troubleshooting	86

V

Vacation program	28, 32
Venting	96

W

Wall installation	15
Warmer	
- Heating	30, 39–40, 44–46

Notes

United States and Canada

Bosch Thermotechnology Corp.
50 Wentworth Avenue
Londonderry, NH 03053
Tel. 603-552-1100
Fax 603-584-1681
www.bosch.us
U.S.A.

Products manufactured by
Bosch Thermotechnik GmbH
Junkersstrasse 20-24
D-73249 Wernau
www.bosch-thermotechnology.com

Bosch Thermotechnology Corp. reserves the right
to make changes without notice due to continuing
engineering and technological advances.



067206432561