



# Hydronic Heating and Plumbing Products





## Service and support from the most trusted name in the industry - Bell & Gossett®.

The Bell & Gossett name has always stood for uncompromising quality and dependability. That's evident in the way our products are built and backed by our outstanding customer service and support team.

Your local Bell & Gossett representative is available any time and is an experienced professional with a wealth of technical expertise. In addition to expert system and product application assistance and a wide product inventory warehoused locally, we offer our ESP-Systemwise software selection program.

The Bell & Gossett ESP-Systemwise software helps you design fluid handling systems accurately, effectively and quickly. You get fast, precise equipment selection, pump performance curves, automatic calculations of payback and annual operating costs, equipment schedules, submittals, specifications and more. ESP-Systemwise includes:

- Bell & Gossett centrifugal pumps, packaged systems, hydronic specialties and heat exchangers
- Domestic® Pump condensate transfer equipment
- Hoffman Specialty® steam specialties

# The Most Complete Line of Hydronic Heating and Plumbing Products.

All from a Single Source - Bell & Gossett.



## Table of Contents

## Page Number

### Pumps

ecocirc Series Heating/Cooling Circulators .....	4-5
ecocirc XL Series Heating/Cooling Circulators .....	6-8
ecocirc e <sup>3</sup> Series Potable Water Pumps .....	9
ecocirc wireless Potable Water Kit .....	10
autocirc Series Potable Water Pumps .....	11
LS Condensate Removal Pump .....	12
ecocirc SC Solar Pump .....	13
NRF (Cast Iron, Maintenance-Free Wet Rotor) .....	14-15
NBF (Bronze, Maintenance-Free Wet Rotor) .....	16-17
SSF (Stainless Steel, Maintenance-Free Wet Rotor) .....	16-17
Series LR™ (Compact Maintenance-Free) .....	17
Series PL™ (Maintenance-Free Dry Motor) .....	18
Three Piece - Oil Lubricated Series 100, HV, PR, 2", 2-1/2" LD-3, HD-3, PD-35, PD-37, PD-38, PD-40 .....	19
Series 60 (In-Line Mounted) .....	20-21

### Pump Accessories

Check-Trol™ Isolation Flow Control Flange .....	22
Isolation and Companion Flanges .....	23

### Controls

ecocirc Series Timer .....	24
NBF Aquastats and Timer .....	24

### Relays

AZ-1A Snap-On Pump Control .....	25
ZONETROL™ Switching Relays .....	26

### Valves

Snap Zone Valve .....	27
Circuit Setter® Plus .....	28
Circuit Sentry™ Flo-Setter™ II .....	29
Flow Control Valves Flo-Control™ .....	30
Flow Control Valves Hydrotrol™ .....	31
Differential Bypass Valves .....	31
Pressure Reducing Valves .....	32
ASME Safety Relief Valves .....	32
Monoflo® Fittings .....	33

### Air Separators

IAS (Inline Air Separators) .....	33
EAS (Enhanced Air Separator) .....	34
EASB-JR (Enhanced Air Separator) .....	34

### Hydronic Specialties

Air Vents .....	35
Vacuum Breaker .....	35
Drain-O-Tank® Air Charger .....	35
Thermoflo® Balancer .....	35
Primary/Secondary Header .....	36

### Tanks

HFT Pre-Charged Hydronic Heating Tanks .....	37
Plain Steel Compression Tanks .....	37
ATF (Airtrol® Tank Fittings) .....	37
PT Diaphragm Tanks .....	38
WTX Diaphragm Tanks .....	38
Tank Purge Valves .....	39

### Heat Exchangers

Brazed Plate Heat Exchangers .....	40-41
------------------------------------	-------

### Wastewater Pumps

Submersible Sump Pumps - SC, SS, GSP0311, BBSP, 2WT .....	42-43
---	-------

# CIRCULATORS ecocirc® auto

## Heating/Cooling Circulator

### Description

ecocirc 19-14 auto are designed, with highly efficient electronically commutated permanent magnet motor (ECM/PM Technology), specifically for hydronic systems.

Ideal for hydronic systems with zone or thermostatic valves, the ecocirc 19-14 auto can be used as replacements for existing circulators with induction motors as well as new construction as primary or zone circulators.

The ecocirc 19-14 auto has a proportional pressure control logic, which allows the pump to slow down automatically as it approaches shut off condition (as the valve closes) then ramp up when the demand increases (as the valve opens).

It includes a step-less dial to adjust the speed to meet the system requirements.



auto

### Materials of Construction

- Pump Body: Cast Iron
- O-Ring: EPDM
- Bearing: Carbon/Alumina Ceramic
- Impeller: Nylon/PPO
- Motor: High Efficiency ECM/PM
- All Other Wetted Parts: Stainless Steel

### Operating Data

- Maximum Working Pressure: 150 PSI (10 Bar)
- Maximum Working Temperature: 203°F (95°C)
- Minimum Working Temperature: 40°F (4°C)

### Motor

- ECM/PM Spherical Motor
- 115 Volts, 60 HZ, 1 Phase
- 60 Watts Max Power Consumption
- Automatic Overload Protection
- Low in-rush current

### Piping Connection

- Flanged, 2-Bolt
- For use with ¾, 1, 1¼, or 1½ inch pipe

Step-less speed dial with LED for pump status and troubleshooting

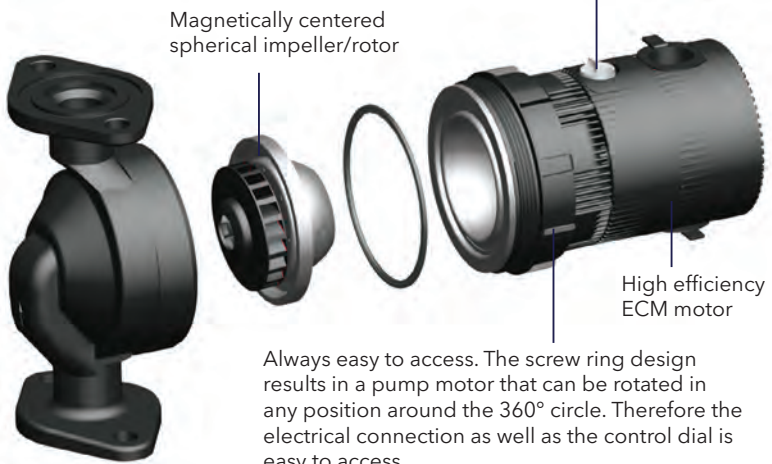

Magnetically centered spherical impeller/rotor

High efficiency ECM motor

Always easy to access. The screw ring design results in a pump motor that can be rotated in any position around the 360° circle. Therefore the electrical connection as well as the control dial is easy to access.

### Built-in Software Protection (for auto and vario)

ecocirc 19-14 has built-in protection to protect from installation errors and improper usage.

There is an overload protection to protect the electronics from over-current or over-voltage input. To further protect the electronics from damage, there is an over-temperature protection. This built-in protection will first slow the speed down to continue operation, but will shut down if the temperature of the electronics continues to rise to high levels.

The circulator is also protected against dry-run condition. Built-in software will recognize a change in performance and determine that the circulator is dry-running. Automatically the circulator will stop operating and will need to be reset to continue operation.

The circulator continually monitors the system for any change in power input or dry-run condition or electronic's temperature. If any error is detected, the circulator will shut down and will need to be reset to continue operation after the error has been fixed.

auto pump curves

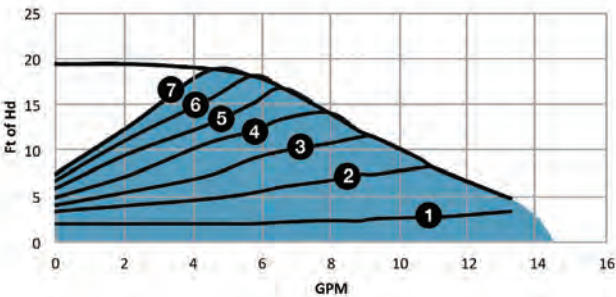

- 1 Setting 1
- 2 Setting 2
- 3 Setting 3
- 4 Setting 4
- 5 Setting 5
- 6 Setting 6
- 7 Setting 7

Model Number	Part Number	Control Mode	Shipping Weight
ecocirc 19-14 auto	6050B2000	auto - Proportional Pressure	9.25 lb

# CIRCULATORS ecocirc® vario

## Heating/Cooling Circulator

### Description

ecocirc 19-14 vario circulators are designed, with highly efficient electronically commutated permanent magnet motor (ECM/PM technology), specially for hydronic systems.

The ecocirc 19-14 vario has a constant curve control, which allows the pump to follow the natural hydraulic curve of a circulator. Basically acts the same as a standard 3-speed pump except with a step-less dial resulting in infinite speed control.

ecocirc 19-14 vario is ideal for replacement for existing circulators with induction motors as well as new construction as primary or zone circulators.



vario

### Materials of Construction

- Pump Body: Cast Iron
- O-Ring: EPDM
- Bearing: Carbon/Alumina Ceramic
- Impeller: Nylon/PPO
- Motor: High Efficiency ECM/PM
- All Other Wetted Parts: Stainless Steel

### Operating Data

- Maximum Working Pressure: 150 PSI (10 Bar)
- Maximum Working Temperature: 203°F (95°C)
- Minimum Working Temperature: 40°F (4°C)

### Motor

- ECM/PM Spherical Motor
- 115 Volts, 60 HZ, 1 Phase
- 60 Watts Max Power Consumption
- Automatic Overload Protection
- Low in-rush current

### Piping Connection

- Flanged, 2-Bolt
- For use with 3/4, 1, 1 1/4, or 1 1/2 inch pipe

### Our design separates the magnetic chamber from the flow (for auto and vario)

Magnetite and sludge, which are both found in the pumped liquid and are both magnetic, can accumulate at the permanent magnetic parts of a high efficiency pump, and therefore block and damage it. The Anti-Block Technology separates the main flow of the pumped media completely from the permanent magnetic parts. It is virtually impossible for the ecocirc auto or vario to block-up even in an old open system.



The main flow of the pumped media (blue) and its magnetite and sludge particles (red) flow outside the influence area of the permanent magnet rotor (bottom).



The side flow of the wet running circulators, which is required for lubrication and cooling of the bearing, is separated from the main flow with its magnetite and sludge.

vario pump curves

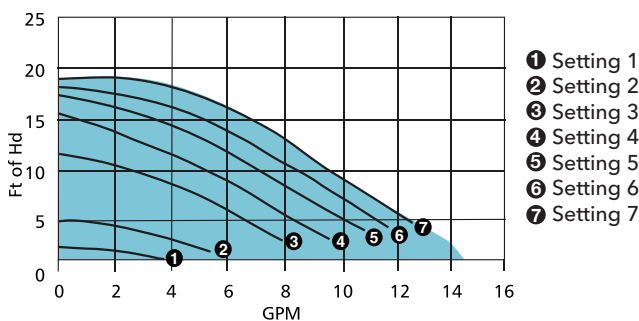

### Dimension (for auto and vario)

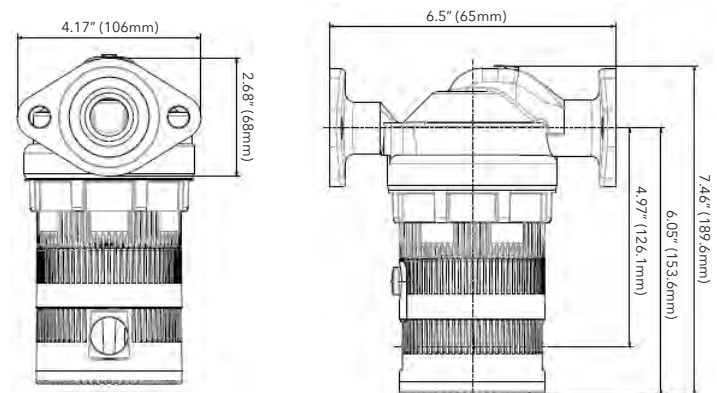

Model Number	Part Number	Control Mode	Shipping Weight
ecocirc 19-14 vario	6050B2001	vario - Constant Curve	9.25 lb

# CIRCULATORS ecocirc® XL

High efficiency large wet rotor pump for heating, cooling and potable water systems

3 Phase models coming soon

## Description

The ecocirc XL is a high efficiency, variable speed, wet rotor pump with integrated drive. The circulator is available in cast iron or lead-free bronze and has a broad operating temperature range of 14°F to 230°F (-10°C to 110°C). The ecocirc XL is suitable for both hot and chilled water systems.

The ecocirc XL circulator is designed with a highly efficient electronically commutated permanent magnet motor (ECM/PM Technology). This circulator can enhance hydronics systems with superior quality and dependability. State-of-the-art hydraulics, advanced motor design, intelligent controls, and smart communication capabilities highlight expert engineering across a board range of HVAC and plumbing applications.

## Materials of Construction

- Pump Body: Cast Iron or Lead-Free\* Bronze
- Impeller: Poly-phenylene Sulfide or Stainless Steel
- Shaft: AISI 420 Stainless Steel
- Rotor: Permanent Magnet
- Bearing: Carbon Sleeve
- Gasket/O-Ring: EPDM
- All Other Wetted Parts: AISI 304 Stainless Steel
- Motor Type: Electronically Commutated Motor /Permanent Magnet
- Motor Insulation Class: F



## Operating Data

- Maximum Working Pressure: 175 PSI (12 Bar)
- Minimum Working Temperature: 14°F (-10°C)
- Maximum Working Temperature: 230°F (110°C)
- Ambient Temperature Range: 32°F - 104°F (0°C - 40°C)

## Safety Standards And Protection

- Enclosure: Class 2, IP44 (equivalent to NEMA Type 2)
- UL Listed to UL 778; UL 1004-1, 1004-7; and UL 60730-1
- cUL Listed to C22.2 #108
- Electronically Thermally Protected (Integrated Motor Protection)
- Motor Insulation Class: F
- CSA certified to NSF/ANSI 372 that product contains less than 0.25% lead content by weight on wetted surface

Cast Iron Body		Lead-Free Bronze Body*		Rated Motor Characteristics					
Model Number	Part Number	Model Number	Part Number	HP**	Voltage	Phase	Hz	Watts Range	AMP Range
ecocirc XL 20-35	104300	ecocirc XL B 20-35	104400LF	1/12	115	1	50/60	6-85	0.1 - 1.3
ecocirc XL 36-45	104301	ecocirc XL B 36-45	104401LF	1/6	115	1	50/60	20-200	0.1 - 3.0
ecocirc XL 36-45	104302	ecocirc XL B 36-45	104402LF	1/6	208-230	1	50/60	20-200	0.1 - 1.5
ecocirc XL 15-75	104303	ecocirc XL B 15-75	104403LF	1/6	115	1	50/60	30-150	0.1 - 2.3
ecocirc XL 15-75	104304	ecocirc XL B 15-75	104404LF	1/6	208-230	1	50/60	30-150	0.1 - 1.1
ecocirc XL 55-45	104306	ecocirc XL B 55-45	104406LF	1/2	208-230	1	50/60	30-500	0.2 - 2.0
ecocirc XL 20-140	104308	ecocirc XL B 20-140	104408LF	1/2	208-230	1	50/60	35-470	0.2 - 2.0
ecocirc XL 65-130	104309	ecocirc XL B 65-130	104409LF	1	208-230	1	50/60	45 - 825	0.5 - 3.5
ecocirc XL 40-200	104312	ecocirc XL B 40-200	104412LF	1	208-230	1	50/60	50 - 825	0.5 - 3.5
ecocirc XL 70-145	104315	ecocirc XL B 70-145	104415LF	2	208-230	1	50/60	55 - 1400	0.6 - 6.0
ecocirc XL 40-275	104318	ecocirc XL B 40-275	104418LF	2	208-230	1	50/60	50 - 1400	0.5 - 6.0

Note: Where potable water is pumped, use a lead-free bronze booster. ecocirc XL pumps are recommended for indoor use only.

\*CSA certified to NSF/ANSI 372 that product contains less than 0.25% lead content by weight on wetted surface.

\*\* Nominal HP

ecocirc XL High Head Performance Range

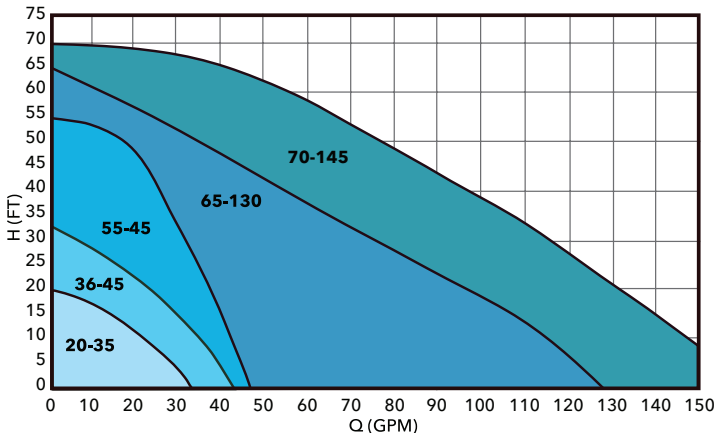

ecocirc XL High Flow Performance Range

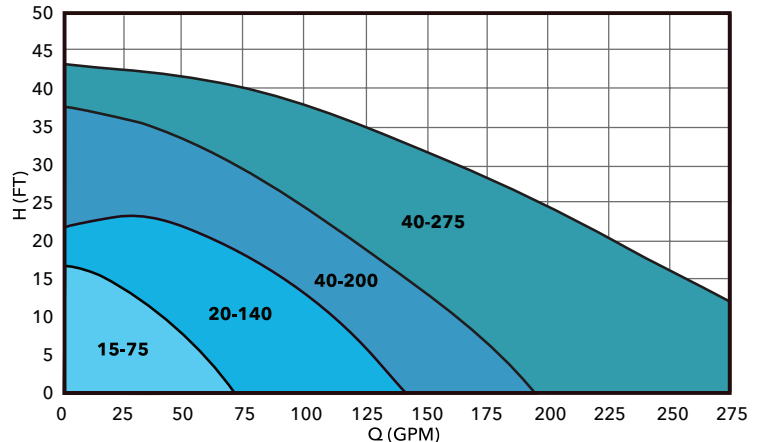

# CIRCULATORS ecocirc® XL

High efficiency large wet rotor pump for heating, cooling and potable water systems

**Self-flushing membrane**  
Allows clean water to cool and lubricate the motor bearing. Restricts entry of abrasive particles.

**Economical operation**  
A highly efficient ECM motor combined with optimized pump hydraulics, keeps operational costs at a minimum.

**User-friendly interface**  
With only four logically placed buttons on an intuitive interface, it's easy to set and operate the new ecocirc XL. Advanced settings enable custom programming, accessible via a PC, smartphone or wireless enabled device.

**High visibility**  
Even in dark mechanical rooms, a bright display with large figures and symbols makes it easy to view pump status.

**Chilled water applications**  
Electronics are separated from the pump to prevent condensation for worry free operation even at 14°F (-10°C).

**Keep it hot or cold**  
A closed, perfectly molded insulation shell preserves a constant temperature of the pumped liquid.

**Sensorless technology**  
The ecocirc XL variable speed drive has the pump's hydraulic performance mapped in memory for multiple RPMs with corresponding electric current values (similar to the ITSC Sensorless VS Drive). The Delta P value associated with the pump's actual operating point is compared to the setpoint Delta P and the controller makes speed adjustments using current to minimize the differences between actual Delta P and setpoint Delta P.

**Increase your control options**  
Multiple inputs including start-stop, temperature control, pressure regulation and advanced Modbus or BACnet control provide dynamic system management.

## Product Range Chart

Model Number	Version		Power Supply		Flange Connection				Pump Body		Fluid Temp. Range	Ambient Temp. Range	Max. Pressure Range	Protection Class
	High Head	High Flow	Single Phase 115V	Single Phase 208-230V	Small Booster (2 Bolts)	Large Booster (2 Bolts)	2" Booster (4 Bolts)	3" Booster (4 Bolts)	Cast Iron	Lead-Free Bronze*	14°F - 230°F	32°F - 104°F	175 PSI	IP44
ecocirc XL 20-35	•		•		•				•	•	•	•	•	•
ecocirc XL 36-45	•		•	•	•				•	•	•	•	•	•
ecocirc XL 15-75		•	•	•			•		•	•	•	•	•	•
ecocirc XL 55-45	•			•	•				•	•	•	•	•	•
ecocirc XL 20-140		•		•			•		•	•	•	•	•	•
ecocirc XL 65-130	•			•		•			•	•	•	•	•	•
ecocirc XL 40-200		•		•			•		•	•	•	•	•	•
ecocirc XL 70-145	•			•		•			•	•	•	•	•	•
ecocirc XL 40-275		•		•				•	•	•	•	•	•	•

\*CSA certified to NSF/ANSI 372 that product contains less than 0.25% lead content by weight on wetted surface.

- Small Booster (2 bolts) has a bolt hole to bolt hole dimension of 3-3/16".
- Large Booster (2 bolts) has a bolt hole to bolt hole dimension of 3-7/16".



## Input Signals

- One 0-10V (Analog): Speed Control by external controller
- One 4-20mA (Analog): Connection with an external differential pressure sensor for the pressure control mode (two different pressure sensor range: 0-15 PSI PN: 104503 and 0-30 PSI PN: 104504)
- One external temperature sensor input for either Constant Temperature or Temperature Influenced modes. Sensor PN: 104502
- One built-in temperature sensor for either Constant Temperature or Temperature Influenced modes.

## Remote Building Management System Capabilities

- The pump can be monitored or controlled by a signal from a BMS (Building Management System). Built-in protocols are BACnet and Modbus. Direct connection to a PC is available.
- An optional wireless module can be added to create a short range wireless field for remote connection to the pump. An internet browser or an App can be used to program the advanced settings. Module PN: 104500

# CIRCULATORS ecocirc® XL

High efficiency large wet rotor pump for heating, cooling and potable water systems

## STANDARD OPERATING MODES

### Constant Speed



The pump maintains a constant speed at any flow rate. The desired speed is set on the interface panel of the pump.

### Constant Pressure ( $\Delta p-c$ )



The pump maintains a constant differential pressure at any flow demand until the maximum speed is reached. The desired head of the pump can be set via user interface. Recommended for use in systems with small or constant pressure losses.

### Proportional Pressure ( $\Delta p-v$ )



The differential pressure continuously increases or decreases based on the flow demand. The set point head can be set on the pump user interface. Use for systems with large pressure losses.

### Night Mode



The pump will automatically reduce speed when there is an abrupt change in fluid temperature. The change in fluid temperature is from a boiler operating in night time setback mode. The built-in temperature sensor is used. (Fixed Speed, Constant Pressure, Proportional Pressure)

## CONSTANT TEMPERATURE SPEED CONTROL

### T- Constant Control

This control mode will use a PI algorithm to vary the speed of the pump in order to maintain a constant temperature of the fluid media.

### $\Delta T$ -Constant Control

This control mode will use a PI algorithm to vary the speed of the pump in order to maintain a constant differential temperature between the built-in temperature sensor and external temperature sensor.

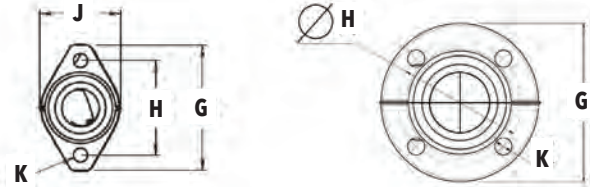
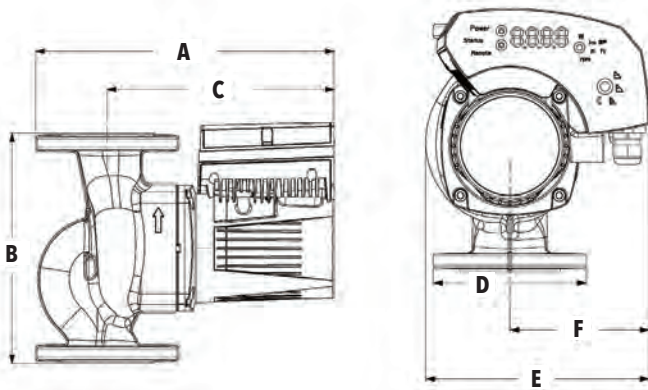

Model Number	Nominal Motor HP	Dimensions - Inches (mm)						Approx. Shipping Weight Lbs. (kg)	
		A	B	C	D	E	F	Cast Iron	Bronze
ecocirc XL 20-35	1/12	9.94 (252)	6.38 (162)	8.20 (208)	4.19 (106)	7.20 (183)	4.72 (120)	19.8 (9)	22 (10)
ecocirc XL 36-45	1/6	9.94 (252)	6.38 (162)	8.20 (208)	4.19 (106)	7.20 (183)	4.72 (120)	19.8 (9)	22 (10)
ecocirc XL 15-75	1/6	11.04 (280)	8.5 (216)	8.39 (213)	5.19 (132)	7.57 (192)	4.72 (120)	26.4 (12)	28.6 (13)
ecocirc XL 55-45	1/2	11.89 (302)	6.38 (162)	10.18 (258)	4.19 (106)	8.12 (206)	5.02 (127)	26.4 (12)	28.6 (13)
ecocirc XL 20-140	1/2	13.39 (340)	11.5 (292)	10.41 (264)	5.19 (132)	8.20 (208)	5.02 (127)	35.2 (16)	39.6 (18)
ecocirc XL 65-130	1	14.84 (377)	11.5 (292)	11.80 (299)	4.62 (117)	9.53 (242)	5.77 (146)	39.6 (18)	44 (20)
ecocirc XL 40-200	1	15.17 (385)	11.5 (292)	11.80 (299)	5.19 (132)	9.53 (242)	5.77 (146)	41.8 (19)	46.2 (21)
ecocirc XL 70-145	2	14.84 (377)	11.5 (292)	11.80 (299)	4.62 (117)	9.53 (242)	5.77 (146)	38.4 (17)	44 (20)
ecocirc XL 40-275	2	16.04 (407)	12.0 (305)	12.57 (319)	6.00 (152)	10.07 (256)	5.77 (146)	49.6 (23)	55 (25)

Model Number	Flange Size Inches - NPT	# of Bolts	Dimensions - Inches (mm)				B&G Companion Flange (Set of 2)	
			G	H	J	K	Cast Iron PN	Bronze PN
ecocirc XL 20-35	3/4, 1, 1-1/4, 1-1/2	2	4.19 (106)	3.16 (80)	2.62 (66)	0.47 (12)	101201 - 101204*	101208LF - 101211LF*
ecocirc XL 36-45	3/4, 1, 1-1/4, 1-1/2	2	4.19 (106)	3.16 (80)	2.62 (66)	0.47 (12)	101201 - 101204*	101208LF - 101211LF*
ecocirc XL 15-75	2	4	5.18 (132)	4.06 (103)	-	0.56 (14)	101215	10216LF
ecocirc XL 55-45	3/4, 1, 1-1/4, 1-1/2	2	4.19 (106)	3.16 (80)	2.62 (66)	0.47 (12)	101201 - 101204*	101208LF - 101211LF*
ecocirc XL 20-140	2	4	5.19 (132)	4.06 (103)	-	0.56 (14)	101215	10216LF
ecocirc XL 65-130	1, 1-1/4, 1-1/2	2	4.62 (117)	3.44 (87)	2.86 (73)	0.47 (12)	101205 - 101207*	101212LF - 101214LF*
ecocirc XL 40-200	2	4	5.19 (132)	4.06 (103)	4.06 (103)	0.56 (14)	101215	10216LF
ecocirc XL 70-145	1, 1-1/4, 1-1/2	2	4.62 (117)	3.44 (87)	2.86 (73)	0.47 (12)	101205 - 101207*	101212LF - 101214LF*
ecocirc XL 40-275	3	4	6.00 (152)	5.06 (129)	-	0.53 (13)	101217	10218LF

\* Part numbers represent a Master Carton of 12 flanges with fasteners pack.  
1-1/2" is the diameter of the suction and discharge for the 2-bolt models.



# CIRCULATORS ecocirc® Series

## Potable Hot Water Recirculation Pumps - Whole House

### Description

e<sup>3</sup> circulators are energy efficient circulators using permanent magnet, ECM (electronically commutated motor) technology. The e<sup>3</sup> circulators are designed specifically for potable water applications. These circulators are lead-free\* and come with a variety of options including a temperature sensor, various body styles, assembled with electrical cord and plug. Timer sold as an accessory (See page 24 for more information).

### Materials of Construction

Pump Body: Lead-Free\* Brass  
 O-Ring: EPDM or Viton  
 Bearing: Carbon/Alumina Ceramic  
 Impeller: Nylon/PPO  
 Motor: High Efficiency ECM  
 All Other Wetted Parts: Type 316 Stainless Steel,  
 Shaft-less and seal-less construction

### Operating Data Pump

Maximum Working Pressure: 150 PSI (10.3 Bar)  
 Maximum Working Temperature: 203°F (95°C)  
 Minimum Working Temperature: 50°F (10°C)

### Motor

ECM Spherical Motor  
 10-28 Watts Power Consumption  
 Automatic Overload Protection  
 Low in-rush current

### Adjustable Speed Switch (Models Without Temp Sensor)

Infinitely variable-speed switch to manually adjust motor speed.

### Adjustable Temperature Sensor (Fixed Speed Only)

Adjustable Set Point from 68°F to 158°F (20°C to 70°C)  
 Turns circulator OFF when water temperature reaches set point  
 Turns circulator ON when water temperature is 10°F (6°C) below set point

### Connections

1/2" UltraCirc with Ball & Check Valve  
 1/2" Sweat  
 1/2" FNPT Threaded

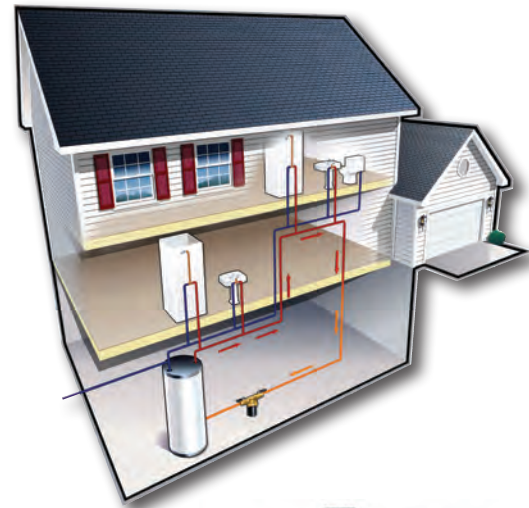

e<sup>3</sup> Timer  
(See Page 24)

e<sup>3</sup> - 4, e<sup>3</sup> - 6

### Pump Curves

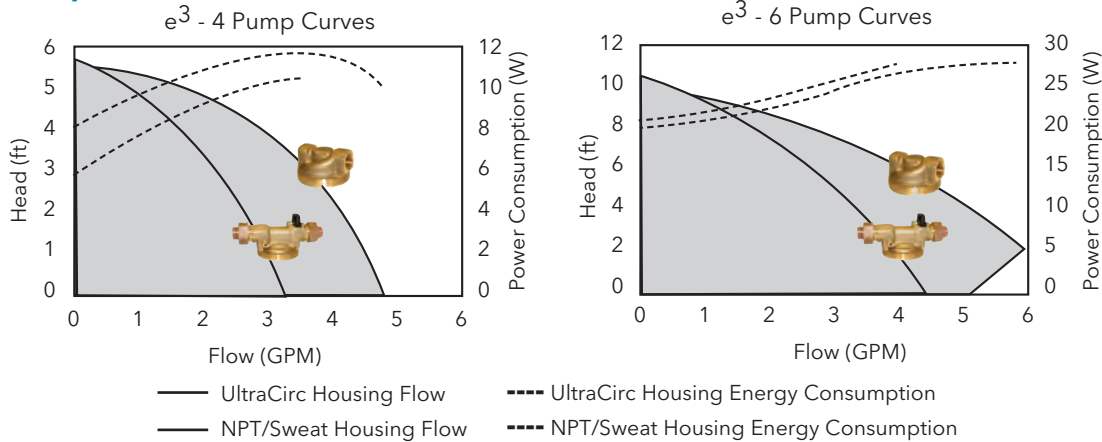

### UltraCirc Pump Housing (Union with Ball & Check Valve)

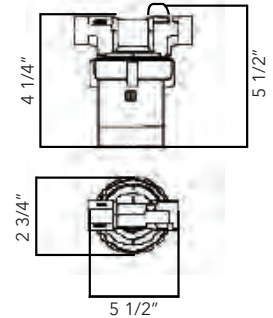

### Standard Pump Housing (Sweat & Threaded)

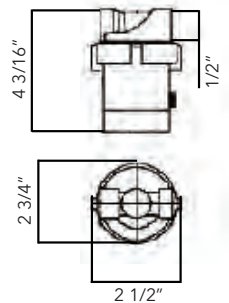

Model Number	Part Number	Materials	Connection		Adjustable Speed	Adjustable Thermostat	Plug
			Size	Type			
e3-4V/BSPYZ	LHB08100101	Lead-Free Brass	1/2"	Sweat	•		•
e3-4_/BSXRZ	LHB08100102	Lead-Free Brass	1/2"	Sweat		•	
e3-4V/BTXYZ	LHB08100104	Lead-Free Brass	1/2"	FNPT	•		
e3-4_/BTPRZ	LHB08100106	Lead-Free Brass	1/2"	FNPT		•	•
e3-6V/BSPYZ	LHB08100109	Lead-Free Brass	1/2"	Sweat	•		•
e3-6V/BTXYZ	LHB08100112	Lead-Free Brass	1/2"	FNPT	•		
e3-6V/BTPYZ	LHB08100110	Lead-Free Brass	1/2"	FNPT	•		•
e3-4V/BUPYZ	6050B5002	Lead-Free Brass	1/2"	Union	•		•
e3-4_/BUPRZ	6050B5003	Lead-Free Brass	1/2"	Union		•	•
e3-6V/BUPYZ	6050B5004	Lead-Free Brass	1/2"	Union	•		•
e3-6_/BSPRZ	6050B5006	Lead-Free Brass	1/2"	Union		•	•
e3-Timer	LHB08260002	-	-	-			

\*CSA certified to NSF/ANSI 372 that product contains less than 0.25% lead content by weight on wetted surface.

# CIRCULATORS ecocirc® wireless

## Potable Hot Water Recirculation Kit

### Description

The ecocirc wireless is a potable hot water recirculation kit (a pump and valve combination) for instant supply of hot water supply throughout the entire house.

The ecocirc pump is installed on the supply side of the hot water source and the mixing valve under the sink farthest away from the hot water source. The pump and valve are in constant wireless communication.

### How it Works

The desired water temperature at the valve is set directly on the pump with the thermostat dial. The water temperature is constantly checked by the valve and the temperature values are sent to the pump. At approximately 5°F below the desired water temperature, the pump will begin to circulate hot water. This circulation will open the valve for hot water to cross into the cold water line, which creates a return loop back to the hot water source. When the desired temperature is reached, the pump will stop circulating. This is to prevent continuous circulation.

### An Optional Push Button / Signal Repeater

A wireless device to provide instant hot water with a push of a button. The push button device will override the timer operation and activate the pump to circulate hot water until the desired temperature is met at the valve. This device also functions as a signal repeater when the pump and valve have a weak signal due to distance or interference.



### Operating Data

Maximum Operating Temperature: 203°F (95°C)  
 Maximum Operating Pressure: 145 PSI (10 Bar)  
 Power Supply: 115 Volts, 60 HZ, 1 Phase  
 Power Consumption: 20 Watts  
 Operating Noise Level: 30 dB  
 Batteries: 2 AA Alkaline  
 Estimated Battery Life: 2 Years  
 Maximum Transmitter Range: 150 ft

### Materials of Construction

Circulator Pump	Paired Mixing Valve
Body: Lead-Free* Brass	Body: Lead-Free* Brass
Seals: EPDM	Springs: Stainless Steel
Impeller: Nylon/PPO	Valve Insert: Acetal Plastic
Internals: 316 Stainless Steel	Seals: EPDM
	Transmitter Housing: ABS Plastic

\*CSA certified to NSF/ANSI 372 that product contains less than 0.25% lead content by weight on wetted surface.

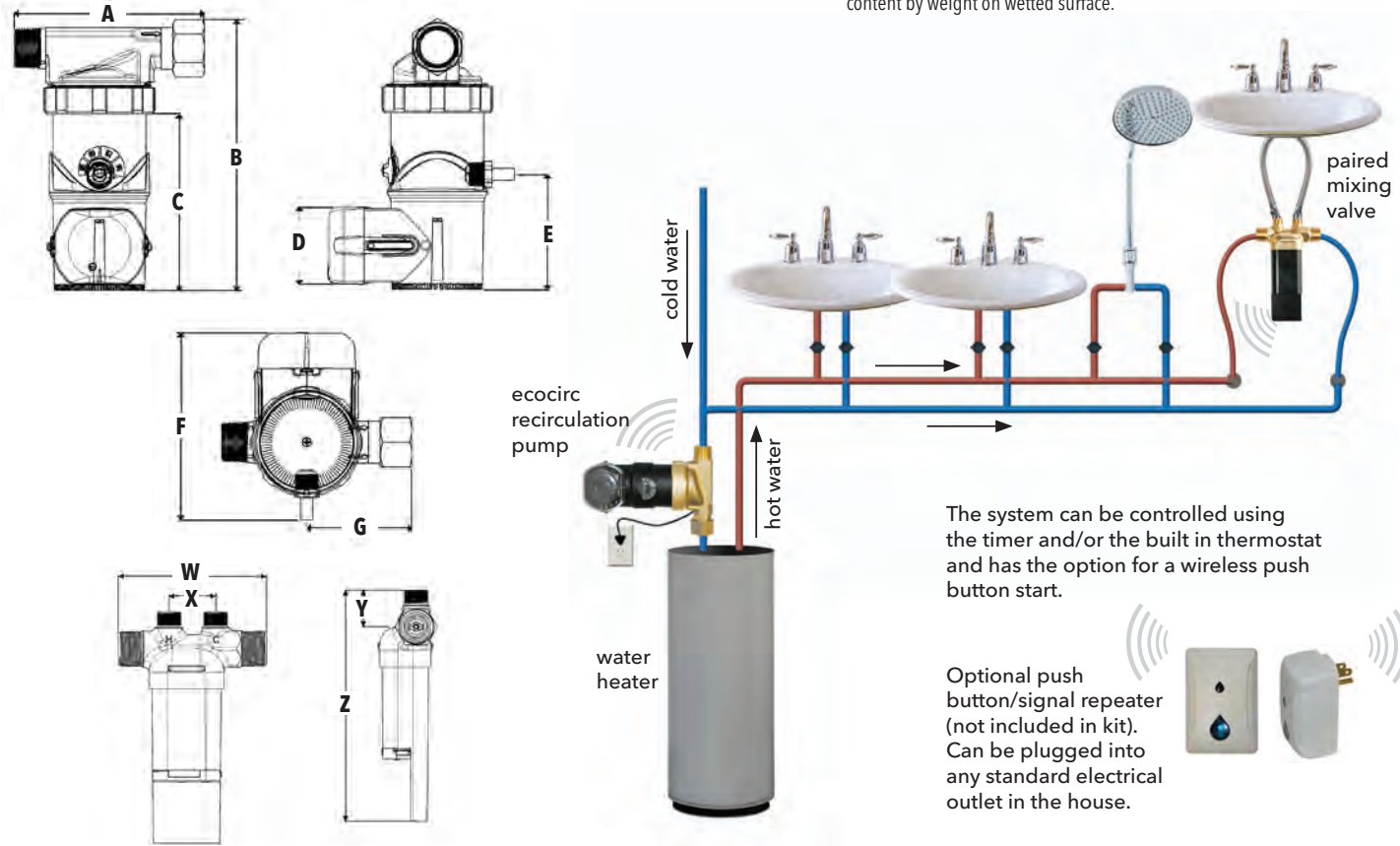

The system can be controlled using the timer and/or the built in thermostat and has the option for a wireless push button start.

Optional push button/signal repeater (not included in kit). Can be plugged into any standard electrical outlet in the house.

Model Number	Part Number	Connection	Dimension Inches (mm)											Shipping WT. LBS. (kg)
			A	B	C	D	E	F	G	W	X	Y	Z	
ecocirc wireless Recirculation Kit	6050B4000	Pump: 3/4" M/F NPT Valve: 1/2" MNPT x 3/8" compression	4.84 (123)	6.87 (174.6)	4.47 (113.5)	1.97 (50.1)	2.93 (74.4)	4.74 (120.5)	2.68 (68)	3.5 (89)	1.1 (28)	0.87 (22)	5.45 (138.5)	3.9 (1.8)
Push Button/Signal Repeater	6099B1500													

# CIRCULATORS autocirc® Series

## Potable Hot Water Recirculation Pumps - Undersink

### Description

autocirc® circulators are energy efficient using permanent magnet, ECM (electronically commutated motor) technology. The autocirc circulators are designed specifically for standard water heaters. These circulators are lead-free\* and are assembled with a timer, cord and plug.

### Materials of Construction

Pump Body: Lead-Free\* Brass  
 O-Ring: EPDM  
 Bearing: Carbon/Ceramic  
 Impeller: Nylon/PPO  
 Motor: High Efficiency ECM  
 All Other Wetted Parts: Type 316 Stainless Steel,  
 Shaft-less and Seal-less construction.

### Operating Data Pump

Maximum Working Pressure: 145 PSI (10 Bar)  
 Maximum Working Temperature: 203°F (95°C)  
 Minimum Working Temperature: 50°F (10°C)

### Motor

ECM Spherical Motor  
 115 Volt 60 Hz, 1 Phase  
 14 Watts Power Consumption  
 Automatic Overload Protection  
 Low in-rush current

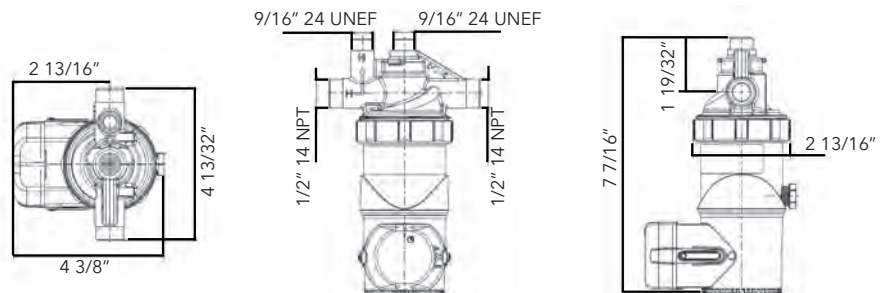
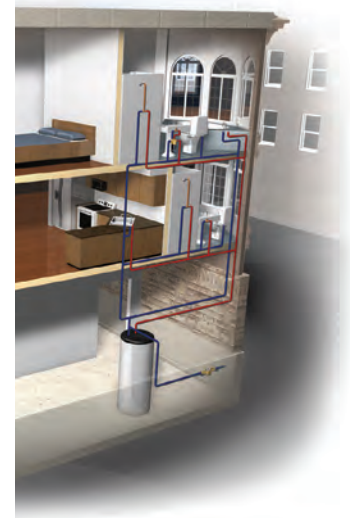

Model Number	Part Number	Description	Weight
e <sup>3</sup> -4_-/BDPQC	LHB08100098	Lead-Free Brass autocirc 1/2" Fixed Thermostat with Timer	4 lbs.
e <sup>3</sup> -4_-/BDPRC	LHB08100099	Lead-Free Brass autocirc 1/2" Adjustable "ON" Thermostat with Timer	4 lbs.

\*CSA certified to NSF/ANSI 372 that product contains less than 0.25% lead content by weight on wetted surface.

# CIRCULATORS ecocirc® B 23-5 ACT

## Potable Hot Water Recirculation Pumps - Undersink

### Description

The ecocirc B 23-5 ACT lead-free\* pump was designed with highly efficient electronically commutated permanent magnet motor (ECM/PM technology) specifically for potable water systems. This unique design is perfect for retrofits and systems with tankless water heaters. No recirculation pipe is required.

### Materials of Construction

Pump Body: Lead-Free\* Brass  
 O-Ring: EPDM  
 Bearing: Carbon/Ceramic  
 Impeller: Nylon/PPO  
 Motor: High Efficiency ECM  
 All Other Wetted Parts: Type 316 Stainless Steel,  
 Shaft-less and Seal-less construction

### Operating Data Pump

Maximum Working Pressure: 145 PSI (10 Bar)  
 Maximum Working Temperature: 203°F (95°C)  
 Minimum Working Temperature: 50°F (10°C)

### Motor

ECM Spherical Motor  
 115 Volt 60 Hz, 1 Phase  
 60 Watts Power Consumption  
 Automatic Overload Protection  
 Low in-rush current



ecocirc B 23-5 ACT

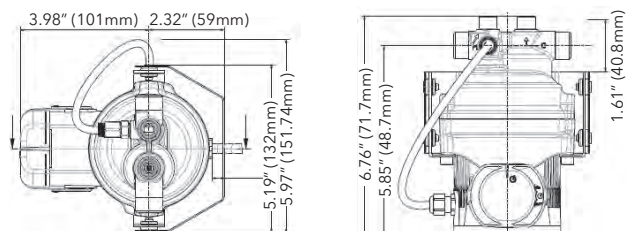

Model Number	Part Number	Description	Weight
ecocirc B 23-5 ACT	6050B7016	Lead-Free Brass autocirc 1/2" Fixed Thermostat with Timer	6.50 lbs.

\*CSA certified to NSF/ANSI 372 that product contains less than 0.25% lead content by weight on wetted surface.

# CIRCULATORS LS Condensate Removal Pump

## For Condensing Boilers and Air Conditioning /Cooling Systems

### Description

The LS condensate removal pumps are energy efficient lifting stations that use permanent magnet, ECM (electronically commutated motor) technology. The LS condensate removal pumps are designed specifically for use in applications where the removal of condensate fluid is not possible by gravity.

### Materials of Construction

Pump Housing: ABS Material  
 O-Ring: EPDM or Viton  
 Bearing: Carbon/Alumina Ceramic  
 Impeller: Nylon/PPO  
 Motor: High Efficiency ECM  
 All Other Wetted Parts: Type 316 Stainless Steel,  
 Shaft-less and Seal-less Construction

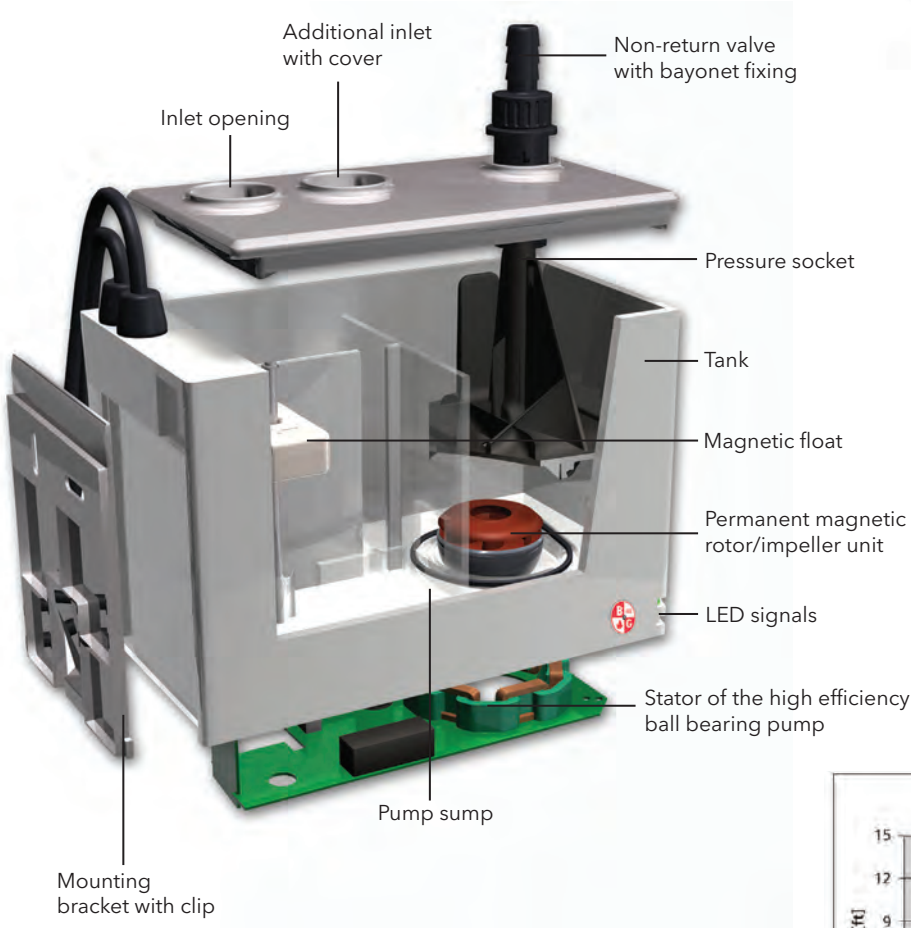

### Standard Features

Motors are designed with a shaft-less spherical motor with permanent magnet technology for improved efficiency.

### Motor

ECM Spherical Motor  
 Phase: Single 60 Hz  
 Voltage: 100-140 volts  
 Power Consumption: 20 watts  
 Current draw: 0.1 - 0.2A  
 Automatic Overload Protection  
 Low in-rush current

### Acid Resistant

All LS condensate removal pumps are made from acid resistant ABS material

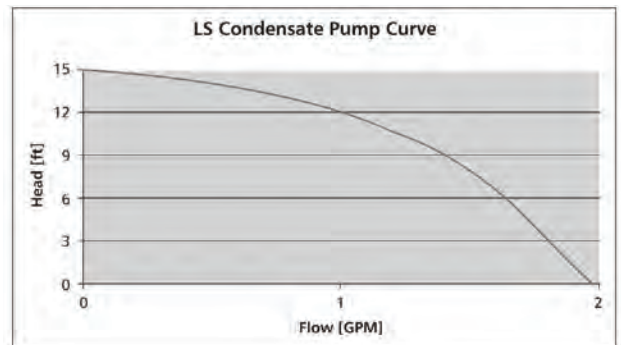

Model	Part Number	Housing Material	Motor	Weight
LS Condensate Pump	6098B0000	ABS	ECM	3.5 lbs

# CIRCULATORS ecocirc® SC Solar Pump

## Spherical Motor Pump

### Application

- The ecocirc solar pump can be used for most circulation pump applications without connection to the power grid with direct connection to a photovoltaic panel.
- This pump is perfect for single family home thermal solar systems or any circulation pump application where conventional power is not available, on closed loop systems

### Design

- The only moving part is a hemispherical rotor/impeller unit which sits on an ultra-hard, wear-resistant ceramic ball.
- There are no conventional shaft bearings or seals eliminating bearing noise and seal leaks.
- This pump is robust and has an estimated service life in excess of 50,000 hours.
- All parts exposed to the fluid are completely corrosion resistant.

### Soft Start-up

- When the photovoltaic panel provides sufficient power, the pump goes through the alignment phase by turning the rotor into the position required for start-up.
- The processor then waits until the capacitor is sufficiently charged.
- This enables a start-up with minimal power (less than one watt).

### Over-temperature Safety Device

- The ecocirc solar pump comes with an integrated over-temperature safety device which shuts off the pump electronics when reaching temperatures over 230°F.
- After reaching a critical temperature 203°F the pump will lower its speed automatically in order to avoid a total shutdown.

### Materials of Construction

Pump Body: Lead-Free\* Brass  
 O-Ring: EPDM  
 Bearing: Carbon/Alumina Ceramic  
 Impeller: PPO  
 Motor: High Efficiency ECM  
 All Other Wetted Parts: Type 316 Stainless Steel  
 Shaft-less, Seal-less Construction

### Technical Data

Motor Design: Electronically commutated spherical motor with permanent magnet rotor/impeller  
 Voltage: 12 - 24 Volt  
 Maximum System Temperature: 203°F (95°C)  
 Maximum Pressure: 150 PSI  
 Power Consumption\*: Min. start-up power consumption less than 1 Watt, max. power consumption 22 Watts  
 Current Draw: 0.25 - 1.46 A  
 Acceptable Media: Potable hot water recirculation, heating water, water/glycol mixtures, other media on request\*\*  
 Environment: IP 42  
 Insulation Class: Class F

\* Power consumption and start may vary in different installations. \*\*Please check pump performance with more than 20% glycol.

### Available Models

Model	Part Number	Description	Weight
e <sup>3</sup> -SC6S	6055B2000	Lead-Free Brass* Solar Circulator 1/2" Sweat	2 lbs.
e <sup>3</sup> -SC6N	6055B2001	Lead-Free Brass* Solar Circulator 1/2" NPT	2 lbs.
e <sup>3</sup> -SC4U	6055B2002	Lead-Free Brass* Solar Circulator 1/2" Union Sweat**	2 lbs.

\*CSA certified to NSF/ANSI 372 that product contains less than 0.25% lead content by weight on wetted surface.

\*\* Built-in ball check valve and purge valve.

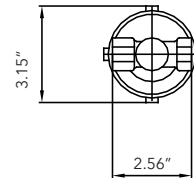
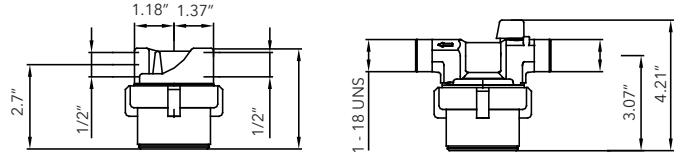

e<sup>3</sup>-SC6N and e<sup>3</sup>-SC6S

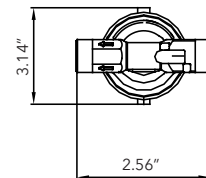

e<sup>3</sup>-SC4U

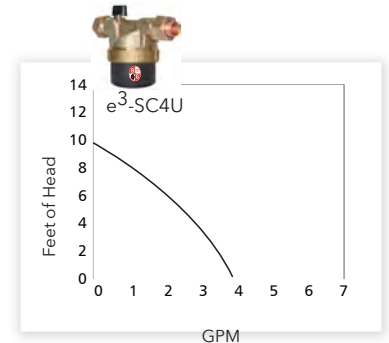
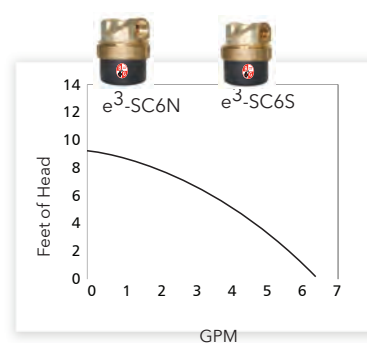

# CIRCULATORS Bell & Gossett Cast Iron Wet Rotor Circulators / NRF

## Description

A residential or light commercial, maintenance free, axial flanged, in-line, cast iron, wet rotor circulation pump for hydronic heating systems. UL and cUL Listed.

## Operating Data

Maximum Working Pressure: 150 PSI (10 bar)

Maximum Operating Temperature:

NRF-22 & NRF-9F/LW: 240°F (115°C)

NRF-25, NRF-33, NRF-36 & NRF-45: 225°F (107°C)

## Materials of Construction

Pump Body: Cast Iron

Impeller: Noryl

Shaft: Ceramic

Bearings: Double-Sintered Carbon

## Warranty

Bell & Gossett offers a warranty of 3 years from date of manufacture or 18 months from date of installation (which ever comes first) against failure as a result of defects in materials and workmanship.

## Specifications

Model Number	Single Speed	Three Speed	Part Number	Flange Sizes Inches - NPT	Dimensions Inches (mm)			Standard 60 Cycle Motor Characteristics*					Shipping Weight lbs. (Kg)
					A	B	C	Watts	ø	Volts	F.L. Amps	RPM	
NRF-9F/LW	●		103267	3/4, 1, 1 1/4, 1 1/2	6 3/8 (162)	6 3/16 (157)	5 1/8 (130)	41	1	115	0.40	2800	9.3 (4.2)
NRF-22	●		103251		6 3/8 (162)	6 3/16 (157)	5 1/8 (130)	92			0.80	2940	9.3 (4.2)
NRF-25		●	103417		6 3/8 (162)	6 3/16 (157)	5 1/8 (130)	125			1.20	2950	10.4 (4.7)
NRF-33	●		103350		6 3/8 (162)	5 9/16 (141)	4 7/8 (124)	125			1.10	2950	10.4 (4.7)
NRF-36		●	103400		6 3/8 (162)	6 7/8 (175)	5 3/4 (146)	270			2.30	3300	13.1 (6.0)
NRF-45		●	103404	1, 1 1/4, 1 1/2	8 1/2 (216)	7 3/8 (187)	5 3/4 (146)	270			2.30	3300	14.5 (6.6)

NRF-9F/LW, NRF-22, NRF-25 and NRF-33 are impedance protected.

NRF-36 and NRF-45 are thermally protected.

Dimensions are approximate and subject to change. Contact factory for certified dimensions.

## Single Speed NRF Circulator Performance Curves

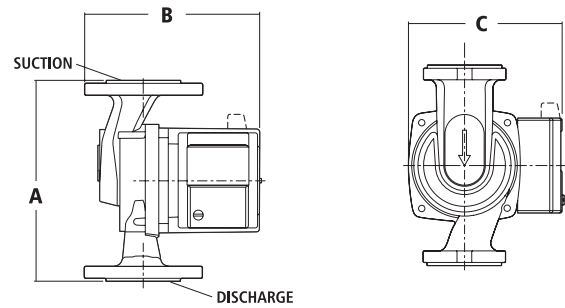
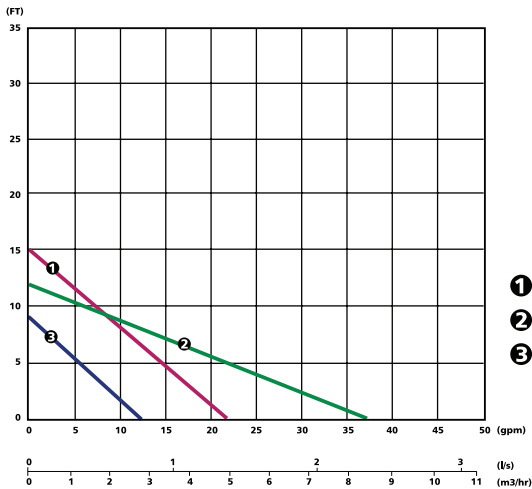

## Single Speed NRF Circulators



NRF-9F/LW



NRF-22



NRF-33



# CIRCULATORS Bell & Gossett Cast Iron Wet Rotor Circulators / NRF

Reliable, maintenance-free, whisper quiet wet rotor circulators designed for residential and light commercial heating systems.

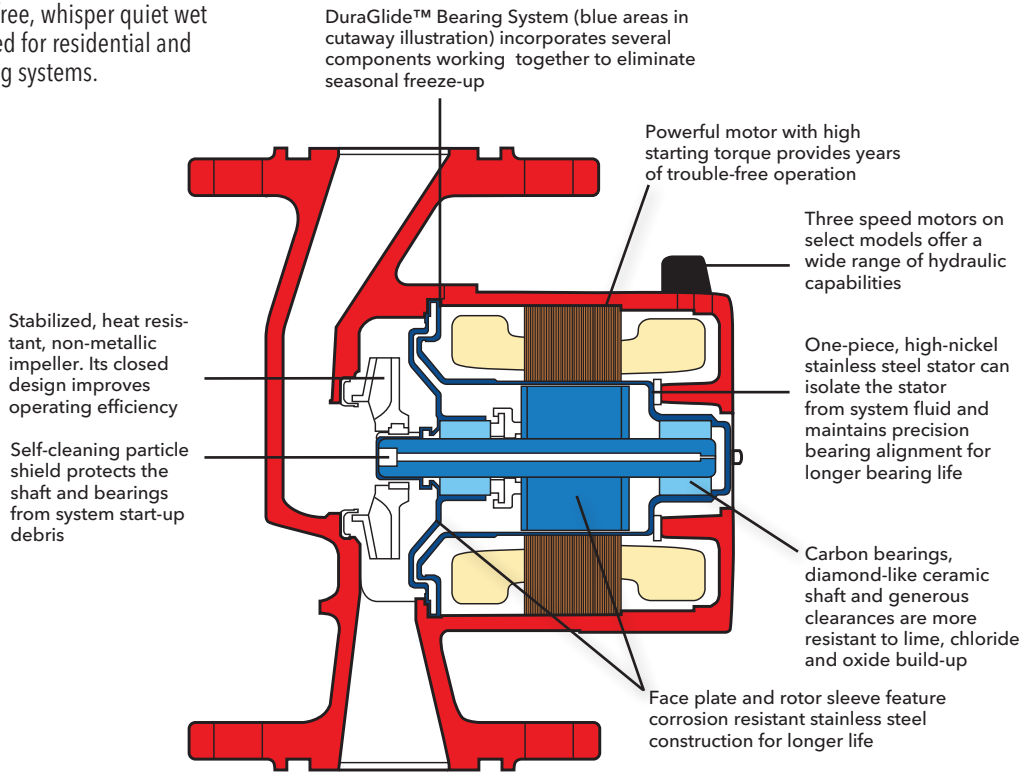

## Three-Speed NRF Circulator Performance Curves

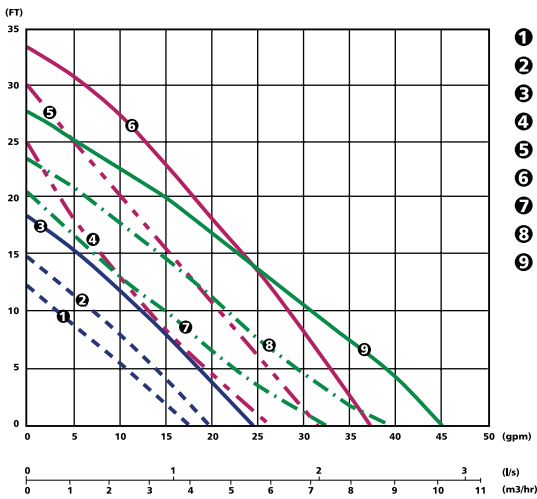

- ❶ NRF-25 Speed 1
- ❷ NRF-25 Speed 2
- ❸ NRF-25 Speed 3
- ❹ NRF-36 Speed 1
- ❺ NRF-36 Speed 2
- ❻ NRF-36 Speed 3
- ❼ NRF-45 Speed 1
- ❽ NRF-45 Speed 2
- ❾ NRF-45 Speed 3

## Optional Zone Pump Relay Control



The ZoneTrol II AZ-1A is a single zone pump relay that turns the pump and boiler on when the thermostat calls for heat. The AZ-1A is ideal when adding a zone to an existing system and can be daisy-chained together to control multiple zones (See page 25.)

## Three-Speed NRF Circulators



**NRF-25**



**NRF-36**



**NRF-45**

# CIRCULATORS Lead-Free Wet Rotor Circulators for Potable Water / NBF & SSF

## Description

A residential or light commercial, maintenance-free, in-line, lead-free\* bronze or stainless steel, wet rotor circulator for potable water systems and other applications. Flanged, union or sweat models available. UL and cUL listed.

## Operating Data

Maximum Working Pressure: 150 PSI (10 bar)  
 Maximum Operating Temperature:  
 NBF-25, NBF-33, NBF-36, NBF-45: 225°F (107°C)  
 All Others: 230°F (110°C)

## Materials of Construction

Pump Body NBF: 100% Lead-Free\* Bronze  
 SSF: Stainless Steel  
 Impeller: Noryl  
 Shaft: Ceramic  
 Bearings: Double-Sintered Carbon

## Warranty

Bell & Gossett offers a warranty of three years from date of manufacture or 18 months from date of installation (which ever comes first) against failure as a result of defects in materials and workmanship.

\*CSA certified to NSF/ANSI 372 that product contains less than 0.25% lead content by weight on wetted surface.



SSF-9



NBF-9

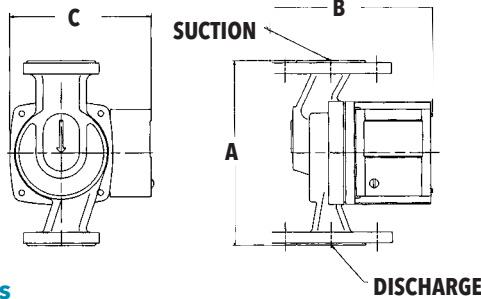

## Cross Reference

BELL & GOSSETT	GRUNDFOS*	TACO**
NBF-8S/LW	UM 15-10B5	003B
NBF-9U/LW	UP 15-18SU	006B
NBF-10S/LW	UP 15-18B5	006B
NBF-12U/LW	UP 15-42SU	005B
NBF-12F/LW	UP 15-42SF	005B
NBF-18S	UP 15-42B5	-
NBF-22U	UP 25-64SU	007B
NBF-22	UP 25-64SF	007B
SSF-22	UP25-64SF	007B
NBF-25	UPS15-58	00R-MS
NBF-33	-	0010B
NBF-36	UP26-96BF	0011B
	UP26-99BF	0013B
	UP26-64SF	0014B
NBF-45	UP43-75BF	-

\*Grundfos is a registered trademark of Grundfos Pumps Corp.

\*\*Taco is a registered trademark of Taco, Inc.

## Specifications

Model Number	Part Number	Connections	Dimensions Inches (mm)			Standard 60 Cycle Motor Characteristics*					Shipping Weight lbs. (Kg)
			A	B	C	Watts	∅	Volts	F.L. Amps	RPM	
NBF-8S/LW	103257LF	1/2" Sweat	5 (127)	5 7/32 (132)	4 7/8 (124)	39	1	115	0.39	2800	9.0 (4.1)
NBF-9U/LW	103258LF	Union**	6 1/8 (156)	5 1/16 (129)	4 7/8 (124)	41			0.40		9.3 (4.2)
NBF-10S/LW	103259LF	1/2" Sweat	5 (127)	5 7/32 (132)	4 7/8 (124)	55			0.46		9.0 (4.1)
NBF-12F/LW	103260LF	Flange 3/4, 1, 1 1/4, 1 1/2	6 3/8 (162)	5 9/16 (141)	4 7/8 (124)	55			0.48		9.5 (4.3)
NBF-12U/LW	103261LF	Union**	6 1/8 (156)	5 1/16 (129)	4 7/8 (124)	55			0.48		9.3 (4.2)
NBF-18S	103316LF	1/2" Sweat	5 (127)	5 7/32 (132)	4 7/8 (124)	90			0.74	3000	9.0 (4.1)
NBF-22	103252LF	Flange 3/4, 1, 1 1/4, 1 1/2	6 3/8 (162)	5 9/16 (141)	4 7/8 (124)	92			0.80	2940	9.5 (4.3)
NBF-22U	103255LF	Union**	6 1/8 (156)	5 1/16 (129)	4 7/8 (124)	92			0.80		9.3 (4.2)
NBF-25	103418LF	Flange 3/4, 1, 1 1/4, 1 1/2	6 3/8 (162)	6 3/16 (157)	5 1/8 (130)	125			2950	1.10	10.4 (4.7)
NBF-33	103351LF	Flange 3/4, 1, 1 1/4, 1 1/2	6 3/8 (162)	6 3/16 (157)	5 1/8 (130)	125				1.10	10.4 (4.7)
NBF-36	103401LF	Flange 3/4, 1, 1 1/4, 1 1/2	6 3/8 (162)	6 7/8 (175)	5 3/4 (146)	270			3300	2.30	13.1 (6.0)
NBF-45	103405LF	Flange 1, 1 1/4, 1 1/2	8 1/2 (216)	7 3/8 (187)	5 3/4 (147)	270				14.5 (6.6)	
SSF-9U/LW	103360LF	Union**	6 1/8 (156)	5 1/16 (129)	4 7/8 (124)	41			2800	0.40	9.3 (4.2)
SSF-12F/LW	103358LF	Flange 3/4, 1, 1 1/4, 1 1/2	6 3/8 (162)	5 9/16 (141)	4 7/8 (124)	55				0.48	9.5 (4.3)
SSF-12U/LW	103361LF	Union**	6 1/8 (156)	5 1/16 (129)	4 7/8 (124)	55				9.3 (4.2)	
SSF-22	103357LF	Flange 3/4, 1, 1 1/4, 1 1/2	6 3/8 (162)	5 9/16 (141)	4 7/8 (124)	92				2940	0.80
SSF-22U	103362LF	Union**	6 1/8 (156)	5 1/16 (129)	4 7/8 (124)	92	9.3 (4.2)				

\* Impedance protected

\*\* Union Connections are available in 3/4" NPT, 1/2" sweat & 3/4" sweat.



# CIRCULATORS Lead-Free Wet Rotor Circulators for Potable Water / NBF & SSF – continued

## Single Speed-NBF/SSF 60 HZ Performance Curve

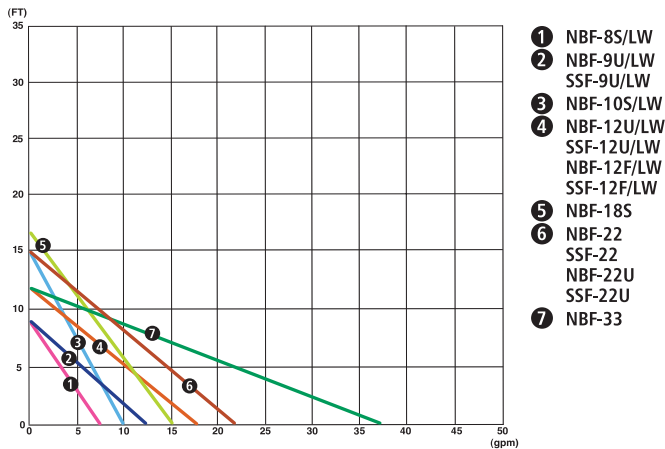

## Three Speed-NBF 60 HZ Performance Curve

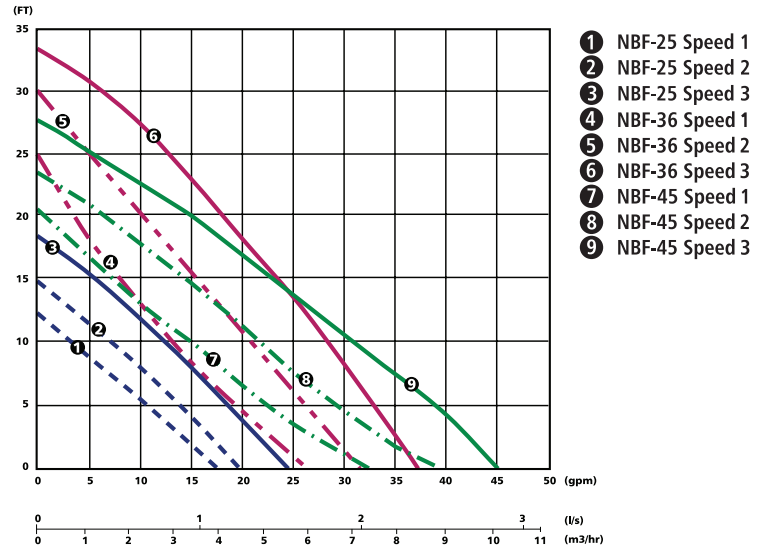

# CIRCULATORS Series LR™ Maintenance-Free Circulators

## Materials of Construction

Pump Body: LR-20WR: Cast Iron  
LR-15BWR: Lead-Free\* Bronze

Impeller: Noryl®

Shaft: Ceramic

Bearings: Carbon

\*CSA certified to NSF/ANSI 372 that product contains less than 0.25% lead content by weight on wetted surface.

## Operating Data

Maximum Working Pressure: 150 PSI (10 bar)

Maximum Operating Temperature: 225°F (107°C)



LR-15B

LR-20

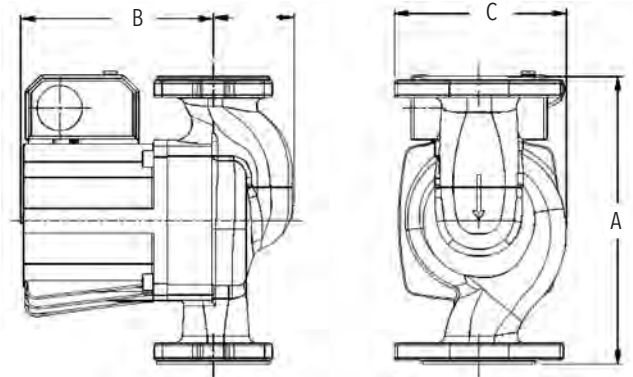
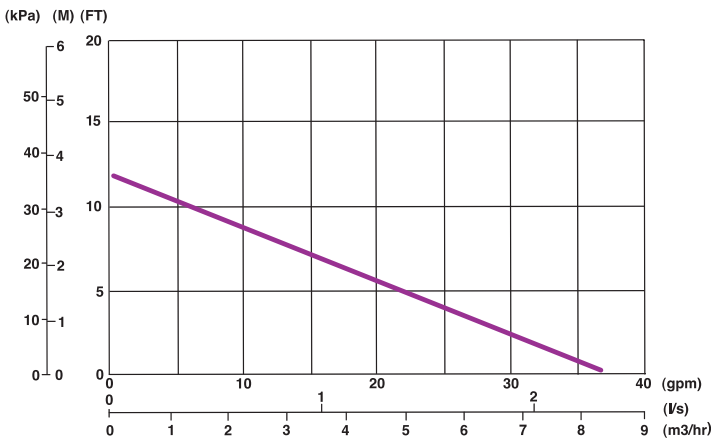

## Specifications

Model Number	Part Number	Pump Body Material	Flange Sizes Inches-NPT	Dimension Inches (mm)			Standard 60Hz Motor Characteristics*				Approx. Shpg. Wt. lbs (Kg)	
				A	B	C	Watts	Ø	F.L. Amps	FL Amps		RPM
LR-20WR	106507	Cast Iron	3/4, 1, 1-1/4, 1-1/2	6-3/8 (162)	6 (152)	3-7/8 (98)	125	1	115	1.10	2950	10.4 (4.7)
LR-15BWR	106514LF	Bronze	3/4, 1, 1-1/4, 1-1/2									

# CIRCULATORS Maintenance-Free Circulators

## SERIES PL™ a superior alternative to large wet rotor pumps



PL-30, 36, 45, 50, 55

PL-75, 130

### Operating Data

Maximum Working Pressure: 150 PSI (10.3 bar)  
Maximum Operating Temperature: 225°F (107°C)

### Materials of Construction

Booster Body: Cast Iron or Lead-Free\* Bronze  
Face Plate: Stainless Steel  
Impeller: 30% Glass Filled Noryl® (PL-55 & PL-130): Glass Filled PPS  
Shaft: Carbon Steel (PL-55 & PL-130): Stainless Steel  
Shaft Sleeve: Stainless Steel (PL-55 & PL-130): None  
Seal: Mechanical, Carbon on Silicon Carbide  
Motor Bearings: Sealed Precision Steel Ball Bearing Permanently Lubricated  
Motor Type: ODP  
Elastomers: EPDM

\*CSA certified to NSF/ANSI 372 that product contains less than 0.25% lead content by weight on wetted surface.

### Specifications

Cast Iron		Lead Free		Flange Size Inches - NPT	Motor Characteristics*			Dimensions in inches (mm) @ 60 Hz (Open Drip-Proof)					Approx. Shipp. Wt. lbs. (Kg)	
Model No.	Part No.	Model No.	Part No.		HP	φ	Voltage	RPM	A	B	C	D		E
PL-30	1BL012	PL-30B	1BL013LF	3/4, 1, 1 1/4, 1 1/2	1/12	1	115	2650	8 5/8 (219)	6 3/8 (162)	7 1/8 (181)	4 3/16 (106)	4 3/8 (111)	11.6 (5.3)
PL-36	1BL001	PL-36B	1BL003LF	3/4, 1, 1 1/4, 1 1/2	1/6			3300	8 5/8 (219)	6 3/8 (162)	7 1/8 (181)	4 3/16 (106)	4 3/8 (111)	13.1 (6.0)
PL-45	1BL002	PL-45B	1BL004LF	1, 1 1/4, 1 1/2	1/6			3300	9 1/8 (232)	8 1/2 (216)	7 1/4 (184)	4 5/8 (117)	4 1/2 (114)	14.5 (6.6)
PL-50	1BL016	PL-50B	1BL017LF	1, 1 1/4, 1 1/2	1/6			3300	9 1/8 (232)	8 1/2 (216)	7 1/4 (184)	4 5/8 (117)	4 1/2 (114)	14.5 (6.6)
PL-55	1BL032	PL-55B	1BL068LF	3/4, 1, 1 1/4, 1 1/2	2/5			3250	9 9/16 (243)	6 3/8 (162)	7 15/16 (202)	4 3/16 (106)	4 3/4 (121)	13.1 (6.0)
PL-75	1BL034	PL-75B	1BL035LF	2	1/6			3400	9 15/16 (252)	8 1/2 (216)	7 3/8 (187)	5 3/16 (132)	4 5/8 (117)	18.5 (8.4)
PL-130/ 2"	1BL063	PL-130B/ 2"	1BL065LF	2	2/5			3200	10 3/4 (273)	8 1/2 (216)	8 1/4 (210)	5 3/16 (132)	5 1/8 (130)	22 (10)
PL-130/ 3"	1BL070	PL-130B/ 3"	1BL072LF	2 1/2 & 3	2/5			3200	10 3/4 (273)	8 1/2 (216)	8 1/4 (210)	6 (152)	5 1/8 (130)	27 (12.2)

\* 230/60/1 motors available upon request. Models PL-75 and PL-130 have four bolt hole flange connection, all others have two bolt hole flange connectors. Dimensions are approximate and subject to changes. Contact factory for certified dimensions.

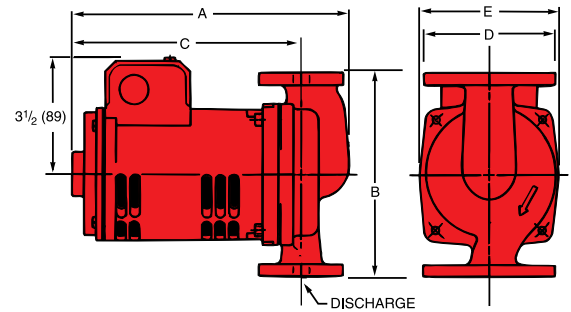
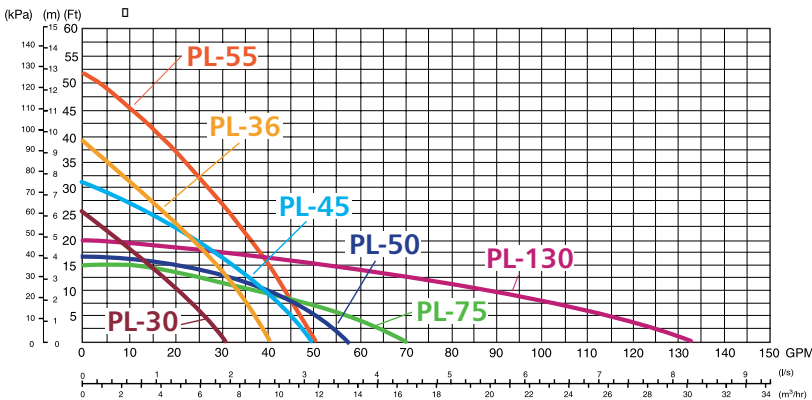

- 1 B&G's powerful, dry-motor design delivers exceptional performance. . . . 25% more efficient than competition.
- 2 Precision-machined and balanced alloy steel rotor for superior performance.
- 3 Quick-connect wire nut leads and dual knock-outs make for fast, sure hook-ups.
- 4 Solid "Stiff-Shaft" design is constructed of high-strength alloy steel impervious to cracking caused by thermal stresses.

- 5 XL-11™ Precision-Crafted Bearing System... is permanently oil lubricated... completely maintenance free... precisely positioned for long-life and isolated for quiet operation.
- 6 Advanced close-coupled design increases pump life and efficiency, assures dependable seasonal start-ups and can easily handle difficult water conditions.
- 7 Tough, durable seal system features a carbon/silicon carbide seal on a stainless steel shaft sleeve for long life and rugged operation.

- 8 Double sided I-Seal™ design for optimum efficiency.

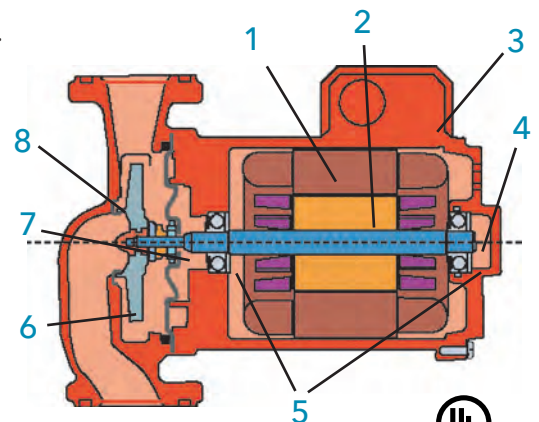

# CIRCULATORS Oil Lubricated Circulators Three-Piece

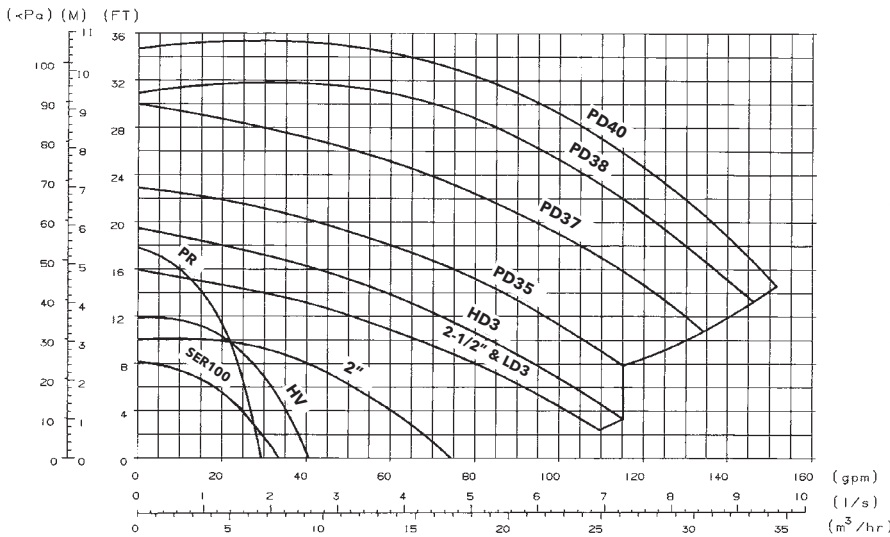

## Operating Data

Maximum Working Pressure: 125 PSI (8.6 bar)  
 Maximum Operating Temperature:  
 Standard Seal: 225°F (107°C) continuous  
 Special Seals: 250°F (121°C) continuous

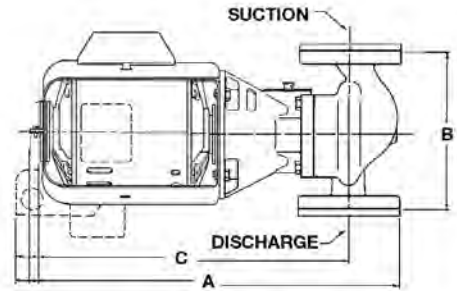

## Specifications

Model Number	Cast Iron		Bronze		Flange Size Inches (NPT)	Motor Characteristics* @ 60 Hz			Dimensions in Inches (mm) (Open Drip-Proof)			Approximate Shpg. Wt. lbs. (Kg)	
	Model Number	Part Number	Model Number	Part Number		HP	Ø	Voltage	A	B	C	Cast Iron	Bronze
Series 100	100NFI	106189	100 AB	106192LF	3/4, 1	1/12	115 - with built-in overload protection	14-7/8 (378)	6-3/8 (162)	12-3/4 (324)	20 (9)	21 (10)	
	100BI	106190	100 BNFI	106197LF	1-1/4, 1-1/2								
Series PR	PR	102206	PR AB	102208LF	3/4, 1	1/6		15-1/4 (387)	8-1/2 (216)	12-3/4 (324)	30 (14)	32 (15)	
	PR BI	102207		102231LF	1-1/4, 1-1/2								
Series HV	HV NFI	102210	HV AB	102231LF	1, 1-1/4, 1-1/2	1/6		15-3/8 (391)	8-1/2 (216)	13 (330)	28 (13)	30 (14)	
	HV BI	102230	HV BNFI	102233LF	1, 1-1/4, 1-1/2								
2"	2 NFI	102214	2 AB	102233LF	2	1/6		16-5/8 (422)	8-1/2 (216)	14 (356)	36 (16)	39 (18)	
	2 BI	102232	2 BNFI	102217LF									
2-1/2"	2-1/2	102218	2-1/2 AB	102220LF	2-1/2	1/4		17-1/4 (438)	10 (254)	14 (356)	54 (24)	58 (26)	
	2-1/2 BI	102219		102224LF									
LD3	LD3	102222	LD3 AB	102224LF	3	1/4		17-1/4 (438)	10 (254)	14 (356)	53 (24)	57 (26)	
	LD3 BI	102223		102228LF									
HD3	HD3	102226	HD3 AB	102228LF	3	1/3	17-1/2 (445)	10 (254)	14-1/4 (362)	55 (25)	59 (27)		
	HD3 BI	102227											
PD-35S	PD35S	105089	PDB35S	105092LF	3	1/2	20-1/4 (514)	12 (305)	16-7/8 (429)	75 (34)	80 (36)		
	PD35S BI	105090											
PD-35T	PD35T	105093	PDB35T	105096LF	3	1/2	20-1/4 (514)	12 (305)	16-7/8 (429)	75 (34)	80 (36)		
	PD35T BI	105094											
PD-37S	PD37S	105097	PDB37S	105100LF	3	3/4	20-1/4 (514)	12 (305)	16-7/8 (429)	75 (34)	80 (36)		
	PD37S BI	105098											
PD-37T	PD37T	105101	PDB37T	105104LF	3	3/4	20-1/4 (514)	12 (305)	16-7/8 (429)	75 (34)	80 (36)		
	PD37T BI	105102											
PD-38S	PD38S	105121	PDB38S	105123LF	3	1	22-3/4 (578)	14-1/2 (368)	19 (483)	128 (58)	138 (63)		
	PD38S BI	105122											
PD-38T	PD38T	105133	PDB38T	105135LF	3	1	24 (610)	14-1/2 (368)	20-1/4 (514)	125 (57)	135 (61)		
	PD38T BI	105134											
PD-40S	PD40S	105151	PDB40S	105153LF	3	1-1/2	24-3/4 (629)	14-1/2 (368)	21 (533)	130 (59)	140 (64)		
	PD40S BI	105152											
PD-40T	PD40T	105137	PDB40T	105139LF	3	1-1/2	21-7/8 (556)	14-1/2 (368)	18-1/8 (460)	127 (58)	137 (62)		
	PD40T BI	105138											

PD-38 and PD-40 are ball bearing, maintenance-free design.

\*Special motors available upon request. Dimensions are approximate and subject to changes. Contact factory for certified dimension.

- 1 B&G Motor – The heart of the booster. The finest circulator motor available. Sleeve bearing, oil lubricated with replaceable resilient motor mounts. B&G motors are designed and manufactured specifically for the B&G boosters.
- 2 Noise dampening coupler. B&G's own flexible spring design adds to quiet operation. Do not accept a substitute.
- 3 Long bronze sleeve bearings maintain exact shaft alignment. Provides for constant circulation of oil over bearing surfaces.
- 4 Precision ground pump shaft is oversized to provide large bearing surfaces. Hardened integral thrust collar minimizes end-thrust to ensure long seal and bearing life.
- 5 The B&G mechanical seal is designed to withstand the wide range of water temperatures, pressures, additives and dissolved solids common in hydronic systems.
- 6 Centrifugal impeller prevents accumulation of air at seal faces to assure long life. Close impeller/body tolerances minimize water slippage and maximize efficiency.

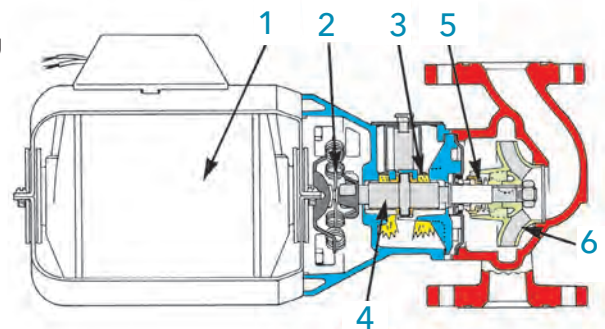

# CIRCULATORS Series e-60 In-Line Mounted Centrifugal Pump Now Available with ECM Motor

## Description

A maintenance-free, in-line, cast iron or cast bronze centrifugal pump with optional built-in simple variable speed capability for some sizes.

## Designed for a variety of applications

- Hydronic heating & cooling systems
- Domestic water
- Fluid transfer
- Header/boiler recirculation

## Product Features

- Maintenance-free pump and motor design
- Unitized internal self-flushing mechanical seal
- XL11® permanent lubrication system
- Factory tested for quality
- ISO 9001 certified
- Durable neoprene coupling
- Compact design
- Easy installation
- Wide range of standard sizes
- Three-year B&G warranty

## Materials of Construction

Body: Cast Iron (Bronze Fitted) or Cast Bronze (All Bronze)  
 Impeller: Cast Bronze  
 Motor Shaft: Alloy Steel  
 Pump Shaft: Steel  
 Volute Gasket: Cellulose Fiber  
 Shaft Sleeve: Copper Alloy  
 Bracket: Cast Iron with Stainless Steel Face Plate: 304 Stainless Steel  
 Mechanical Seal: EPR/Carbon/SIC Standard: -10°F to 225°F

## Operating Data

Maximum working pressure: 175 PSI  
 Working fluid temperature: -10°F to 225°F  
 Temperatures up to 250°F (121°C) with optional Seal

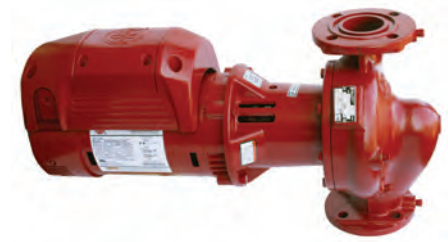

Shown with optional ECM motor

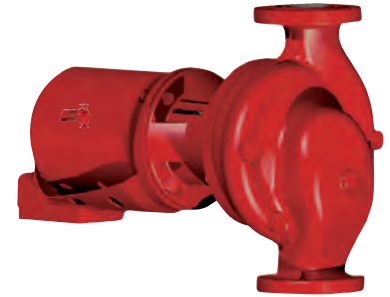

## Unitized internal self-flushing seal

Bell & Gossett's open seal chamber design provides superior flow circulation around the seal faces, resulting in reduced heat buildup, increased particle removal and superior seal-face flushing. The one-piece seal design minimizes internal shear stresses and improves seal alignment, lengthening seal life and reducing friction. These design features contribute to long, reliable seal performance.

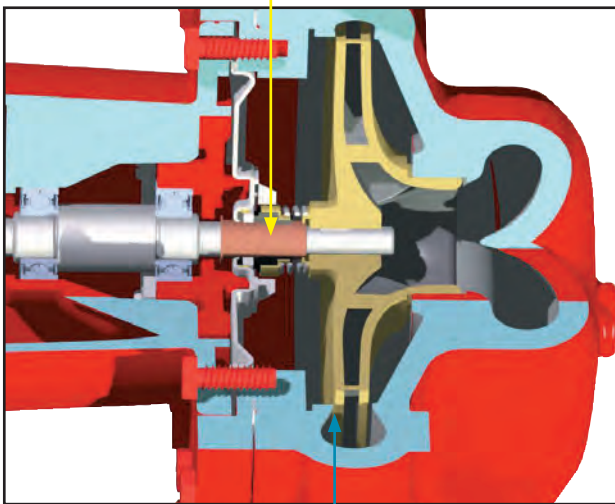

## Impeller

State-of-the-art hydraulically balanced impellers and resilient-mounted motors provide smooth, quiet operation.

## Series e-60 with ECM Motor Pump is 5% quieter than standard Series e-60

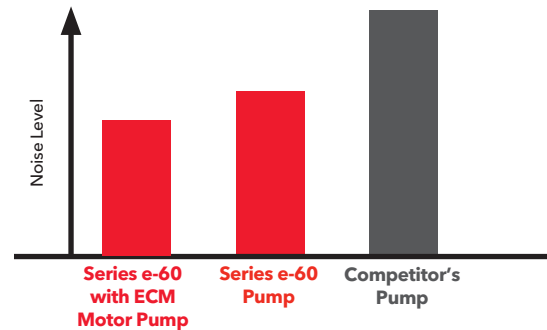

## Quiet operation

The XL-11® Precision-Crafted Bearing System, advanced fluid passage design and B&G permanently lubricated motor come together to deliver smooth, quiet, maintenance-free performance.

## Series e-60 ECM Hydraulic Performance Curves

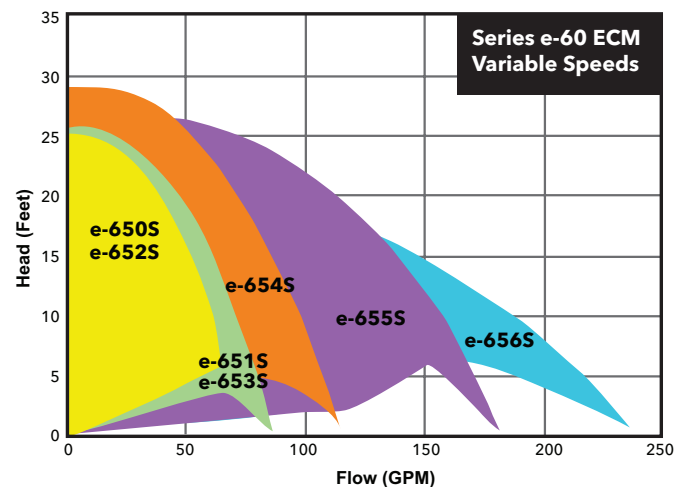

# CIRCULATORS Series e-60 In-Line Mounted Centrifugal Pump

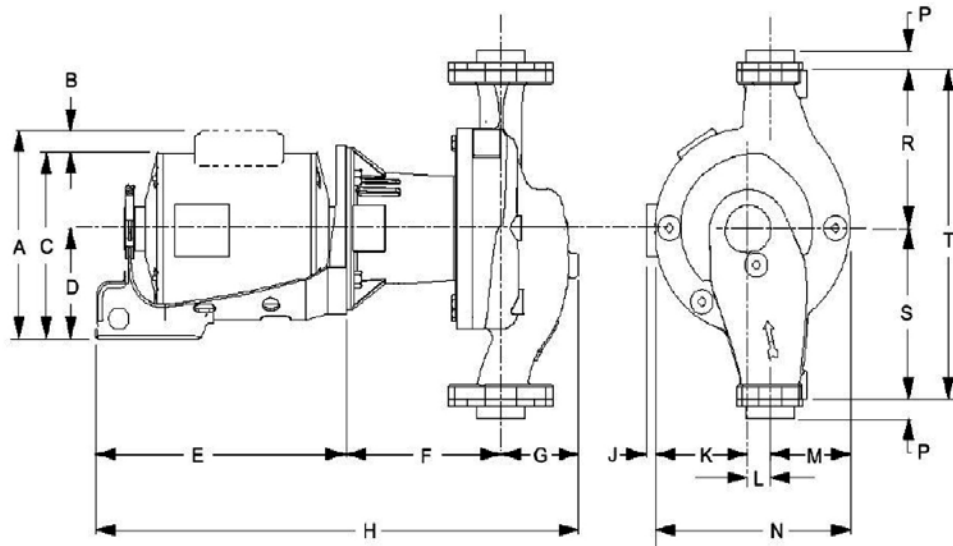
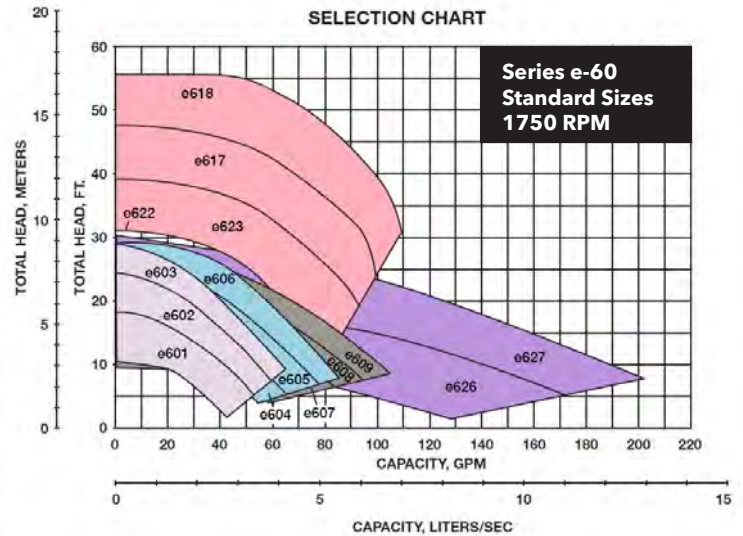
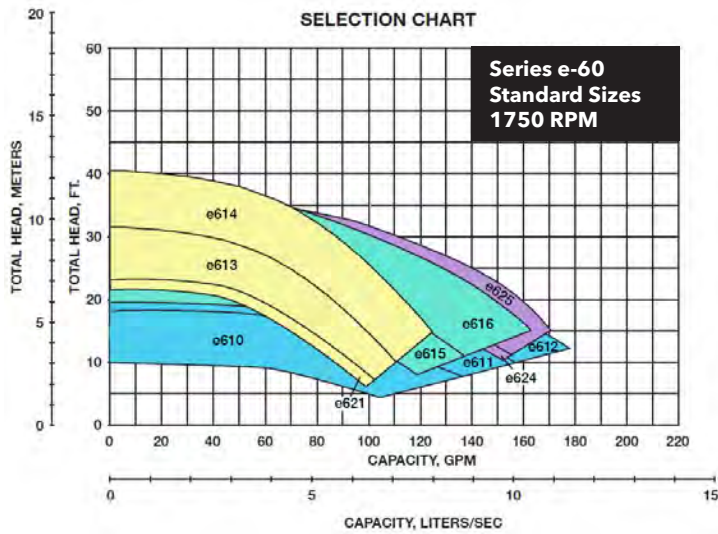

## Specifications

Model	Suction and Discharge Size Inches NPT	Pump Dimension in Inches (mm)									
		F	G	K	L	M	N	P	R	S	T
e601, e602 & e603	1	6-7/16 (164)	3-7/16 (87)	3-5/8 (92)	1-3/8 (35)	2-1/2 (64)	7-1/2 (190)	3/4 (19)	5 (127)	6 (152)	11 (279)
e604, e605 & e606	1-1/4	6-7/16 (164)	3-7/16 (87)	3-5/8 (92)	1-3/8 (35)	2-1/2 (64)	7-1/2 (190)	3/4 (19)	5 (127)	6 (152)	11 (279)
e607, e608 & e609	1-1/2	6-9/16 (167)	3-5/8 (92)	3-3/4 (95)	1-3/8 (35)	2-3/4 (70)	7-7/8 (200)	3/4 (19)	5 (127)	6-1/2 (165)	11-1/2 (292)
e613, e614 & e621	1-1/2	6-11/16 (170)	3-3/8 (86)	4-1/16 (103)	1 (25)	3-9/16 (90)	8-9/16 (217)	3/4 (19)	6-1/2 (165)	7 (176)	13-1/2 (343)
e617, e618, e622 & e623	1-1/2	9-3/8 (238)	3-1/4 (83)	4-5/8 (117)	1 (25)	3-7/8 (98)	9-1/2 (241)	3/4 (19)	6-1/2 (165)	7 (176)	13-1/2 (343)
e610, e611 & e612	2	6-11/16 (164)	3-3/4 (95)	3-3/4 (95)	1-3/8 (35)	2-7/8 (73)	8 (203)	13/16 (21)	5 (127)	6-1/2 (165)	11-1/2 (292)
e615, e616	2	6-15/16 (170)	3-1/2 (89)	4-3/8 (111)	1 (25)	4 (102)	9-3/8 (238)	13/16 (21)	6-1/2 (165)	7 (176)	13-1/2 (343)
e619, e620, e624 & e625	2	9-3/8 (238)	3-1/2 (89)	4-3/4 (121)	1 (25)	4-1/8 (105)	9-7/8 (251)	13/16 (21)	6-1/2 (165)	7-1/2 (165)	14 (356)

Maximum working pressure 175 PSI (12 Bar)

# FLANGES Check-Trol™ Isolation Flow Control Flange

## Description

The Check-Trol flange is a combination isolation valve, flow control valve, and companion flange for circulators. The ball valve allows the circulator to be removed from the system without draining the system. The internal spring check prevents gravity circulation. Free floating companion flange makes pump installation a snap.

## Operating Data

Maximum Working Pressure: 150 PSI (10 bar)  
Maximum Operating Temperature: 200°F (93°C)

## Materials of Construction

Valve Body: Lead-Free\* Brass  
Flange: Chrome Plated Steel  
Ball: Chrome Plated Lead-Free\* Brass  
Packing: PTFE  
Seat Ring: PTFE  
Stem: Lead-Free\* Brass  
Spring Check: Nitrile, Acetal, Stainless Steel

\*CSA certified to NSF/ANSI 372 that product contains less than 0.25% lead content by weight on wetted surface.

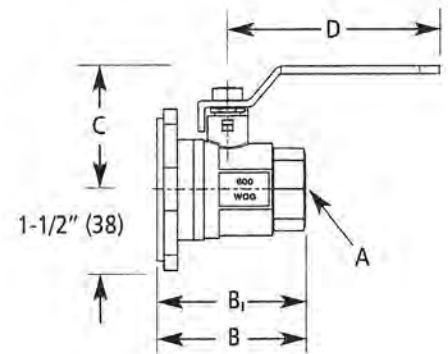
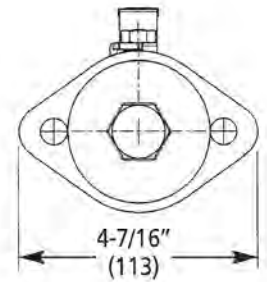
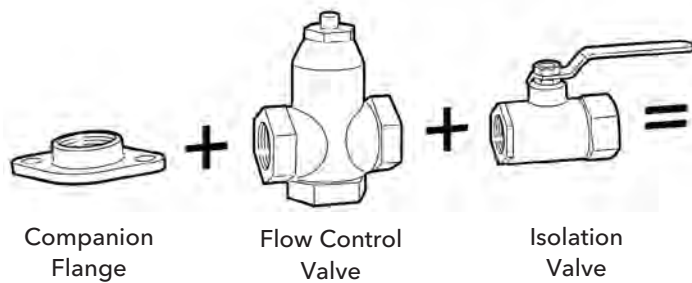

## Specifications

Model Number	Size Inches	Use with Following Circulators	Dimensions - Inches (mm)					Approx. Shpg. Wt. lbs. (Kg)
			A	B	B <sub>1</sub> **	C	D	
101231LF	3/4" NPT x Flange	ecocirc auto and vario	3/4" NPT	3-7/64" (79)	2-27/64" (61.5)	2" (50.5)	4-23/32" (120)	3.4 (1.5)
101232LF	1" NPT x Flange		1" NPT	3-15/16" (100)	2-57/64" (73.3)	2-5/32" (54.7)	4-23/32" (120)	4.4 (2.0)
101233LF	1-1/4" NPT x Flange	ecocirc XL 20-35, 36-45, 55-45	1-1/4" NPT	4-25/32" (121.4)	3-19/64" (84)	3" (76.2)	6-7/32" (158)	6.3 (2.8)
101245LF	1-1/2" NPT x Flange		1-1/2" NPT	4-27/32" (122.9)	3-23/64" (85.5)	3" (76.2)	6-7/32" (158)	6.6 (3.0)
101236LF	3/4" SWT x Flange	NRF/NBF/SSF Wet Rotors*	3/4" SWT	3-21/64" (84.5)	2-41/64" (67)	2" (50.5)	4-23/32" (120)	3.4 (1.5)
101237LF	1" SWT x Flange		1" SWT	4-1/64" (102)	3" (75.3)	2-5/32" (54.7)	4-23/32" (120)	4.2 (1.9)
101238LF	1-1/4" SWT x Flange	Series PL-30, PL-36, PL-55	1-1/4" SWT	4-55/64" (123.4)	3-25/64" (86)	3" (76.2)	6-7/32" (158)	5.9 (2.7)
101247LF	1-1/2" SWT x Flange		1-1/2" SWT	5-1/64" (127.4)	3-35/64" (90)	3" (76.2)	6-7/32" (158)	6.5 (3.0)

\* Not for use with NRF/NBF-45, HV flanges required.

Dimensions and weights are approximate and subject to change. Contact factory for certified dimensions. Check-Trol flange is sold with an isolation flange as a pair.

\*\* B<sub>1</sub> Dimension is overall length of isolation flange. The part numbers and shipping weights are for one Check-Trol flange and one isolation flange, capscrews and nuts.

# ISOLATION FLANGES

## Description

The isolation flange is a combination of an isolation ball valve and a companion flange for circulators. The isolation flange allows easy service or replacement of the circulator without the need to drain the system. The isolation flange fits the Bell & Gossett NRF/NBF/SSF wet rotors, Series PL, Series 100, HV, PR and LR circulators.

## Operating Data

Maximum Working Pressure: 150 PSI (10 bar)  
Maximum Operating Temperature: 250°F (121°C)

## Materials of Construction

Valve Body: Lead-Free\* Brass  
Flange: Chrome Plated Steel  
Ball: Chrome Plated Lead-Free\* Brass  
Packing: PTFE  
Seat Ring: PTFE  
Stem: Lead-Free\* Brass

\*CSA certified to NSF/ANSI 372 that product contains less than 0.25% lead content by weight on wetted surface.

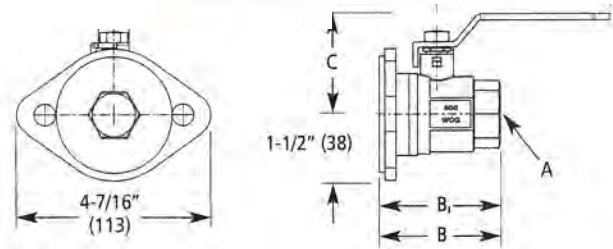

## Specifications

Model Number	Size Inches	Use with Following Circulators	Dimensions - Inches (mm) Following Circulators				Approx. Shpg. Wt. lbs. (Kg)
			A	B	C	D	
101221LF	3/4" NPTF IF	ecocirc auto and vario	3/4" NPT	2-27/64" (61.5)	2" (50.5)	4-47/64" (120)	3.2 (1.5)
101222LF	1" NPTF IF		1" NPT	2-57/64" (73.3)	2-5/32" (54.7)	4-47/64" (120)	4.1 (1.9)
101223LF	1-1/4" NPTF IF	ecocirc XL 20-35, 36-45, 55-45	1-1/4" NPT	3-19/64" (84)	3" (76.2)	6-7/32" (158)	5.8 (26)
101241LF	1-1/2" NPTF IF		1-1/2" NPT	3-23/64" (85.5)	3" (76.2)	6-7/32" (158)	6.1 (28)
101226LF	3/4" SWT IF	NRF/NBF/SSF wet rotors	3/4" SWT	2-41/64" (67)	2" (50.5)	4-23/32" (120)	3.2 (1.5)
101227LF	1" SWT IF		1" SWT	3" (75.3)	2-5/32" (54.7)	4-23/32" (120)	3.9 (1.8)
101228LF	1-1/4" SWT IF	Series PL-30, PL-36, PL-55	1-1/4" SWT	3-25/64" (86)	3" (76.2)	6-7/32" (158)	5.4 (25)
101243LF	1-1/2" SWT IF		1-1/2" SWT	3-35/64" (90)	3" (76.2)	6-7/32" (158)	6 (27)

"IF" = "Isolation Flange"

Note: Dimensions and weights are approximate and subject to change. Contact factory for certified dimensions. The part numbers and shipping weights are for two isolation flanges, capscrews and nuts.

## Companion Flanges

### Flanges for Cast Iron Circulators

	Size (NPT)	Master Carton of 12 Part No.	Set of 2 Part No.
Series 100, PR NRF-22, NRF-9F/LW, NRF-33, NRF-36 PL-30, PL-36, PL-55 ecocirc XL	3/4"	101001	101201
	1"	101002	101202
	1-1/4"	101003	101203
	1-1/2"	101004	101204
Series HV, PL-45 PL-50, NRF-45 ecocirc XL	1"	101005	101205
	1-1/4"	101006	101206
	1-1/2"	101007	101207

	Size (NPT)	Set of 2 Part No.*
PL-75, PL-130/2" ecocirc XL 15-75	2"	101215
PL-130/3" ecocirc XL 40-275	2-1/2"	101219
	3"	101217

\*Includes Fasteners

### Flanges for Bronze Circulators

	Size (NPT)	Master Carton of 12 Part No.	Set of 2 Part No.
Series 100B, PRAB, NBF-22, NBF-12F/LW, NBF-33, NBF-36 PL-30B, PL-36B ecocirc XLB	3/4"	101011LF	101208LF
	1"	101012LF	101209LF
	1-1/4"	101013LF	101210LF
	1-1/2"	101014LF	101211LF
Series HV, PL-45B PL-50B, NBF-45 ecocirc XLB	1"	101015LF	101212LF
	1-1/4"	101016LF	101213LF
	1-1/2"	101017LF	101214LF

	Size (NPT)	Set of 2 Part No.*
PL-75B, PL-130B/2" ecocirc XLB 15-75	2"	101216LF
PL-130B/3" ecocirc XLB 40-275	2-1/2"	101220LF
	3"	101218LF

\*Includes Fasteners

## Union Connection for NBF Circulators

	Union Connection	Set of Two	
		Model No.	Part No.
NBF-22U, NBF-12U/LW NBF-9U/LW	1/2" sweat	UC-1/2S	113203LF
	3/4" sweat	UC-3/4S	113201LF
	3/4" NPT	UC-3/4NPT	113202LF



# CONTROLS ecocirc® e<sup>3</sup> SERIES TIMER

## Description

To increase the overall efficiency of a domestic hot water recirculating system and to reduce water wasted while waiting for hot water, the e<sup>3</sup> Timer can be installed on all e<sup>3</sup> pumps. The timer is easily installed by removing the motor end cap, plugging in the timer and setting the timer schedule without any wiring. The timer can be used in 3-different selections: ON, OFF and TIMER. The ON selection operates the pump continuously, the OFF selection turns the pump OFF and the TIMER selection (depicted by a clock on the timer) turns the pump on when programmed.

## Operational Limits

Power Supply: Internally powered by the e<sup>3</sup> circulating pump  
Minimum Switch Interval: 30 minutes  
Run Modes: ON (Continuous), OFF (Off at all times) and TIMER (run at programmed intervals)

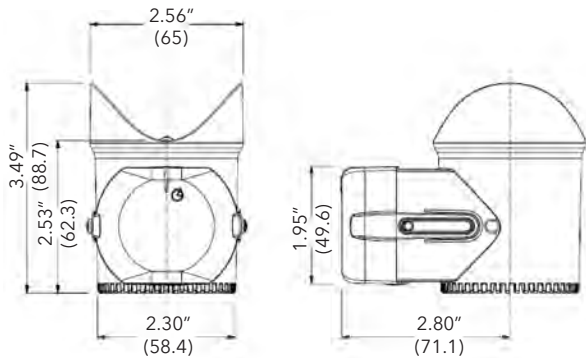

**e<sup>3</sup> Timer**  
(Part No. LHB08260002)



**Pump not included**

## CONTROLS for NBF Circulators



### TC-1 Automatic Timer Kit (Part No. 113210)

To increase the overall efficiency of a hot water recirculation system, the TC-1 timer control kit can be installed for use on any B&G NBF circulator. The TC-1 timer control is programmable to turn the circulator ON and OFF automatically at preset times. This permits the user to have the pump circulate hot water only during those times when high usage can be expected throughout the day. Power supply minimum interval switch is 15 minutes. Run modes maximum switch current is 16 amps.



### AQS-1/2 (Part No. 113223) and AQS-3/4 (Part No. 113224) Aquastat

Designed to thermostatically turn any B&G NBF circulator ON and OFF. The AQ-1/2 or AQ-3/4 will switch the pump OFF at 120°F (48.9°C) and ON at 100°F (37.8°C). The aquastats are available in separate models that will sense the temperature for either 1/2" or 3/4" copper pipe.

AQS-1/2" clips onto 1/2" copper pipe or 3/8" steel pipe  
AQS-3/4" clips onto 3/4" copper pipe or 1/2" steel pipe



# RELAYS ZONETROL II AZ-1A™ Snap-On Pump Relay

## Description

The ZONETROL II AZ-1A snap on relay box is an easy to install single zone pump controller that mounts directly on any Bell & Gossett wet rotor circulator NRF/NBF or Series PL booster. The AZ-1A turns the pump and boiler ON as thermostat calls for heat. Using the wire nuts provided with the package, the AZ-1A is quickly assembled onto any NRF/NBF or 1/12 to 1/6 HP Series PL. The clearly marked TT terminals for the thermostat and the XX isolated end switch terminals make the rest of the hook-up a snap. The AZ-1A can be daisy-chained together to form a maximum of three zones.

The Bell & Gossett AZ-1A is ideal for any single to three zone pump application. Or can be used when adding a zone to an existing system. There's no more need to have a pump controller hanging on the wall, simply install the AZ-1A to our NRF/NBF or Series PL circulators and you are finished.



## Features

- Snap-on design allows the AZ-1A to be quickly attached to any B&G wet rotor circulator, reducing your inventory investment (no need to carry "special" circulators with factory mounted controllers)
- Clearly marked terminals make for sure, fast wiring of the system
- Compact design fits in tight locations and presents a clean professional appearance
- 100% factory tested assures reliable operation
- 5 year warranty – the best in the industry
- Daisy-Chain the AZ-1A relays to form up to three zones
- Can be used on any B&G model NRF, NBF or 1/12 to 1/6 HP Series PL pumps

## Specifications

Model Number	Part Number	Transformer	Relay	Power Input
AZ-1A	109423	2.5 VA	24 VAC / 5 amps	115 V, 60 Hz, 1Ø

Dimensions (L x W x H): 2-7/8" X 3-1/4" X 2-5/8"  
 Approximate Shipping Weight: 0.75 lbs



The AZ-1A can be daisy-chained to form up to three zones with simplified wiring.

Low voltage wiring makes multiple relay connections a snap.

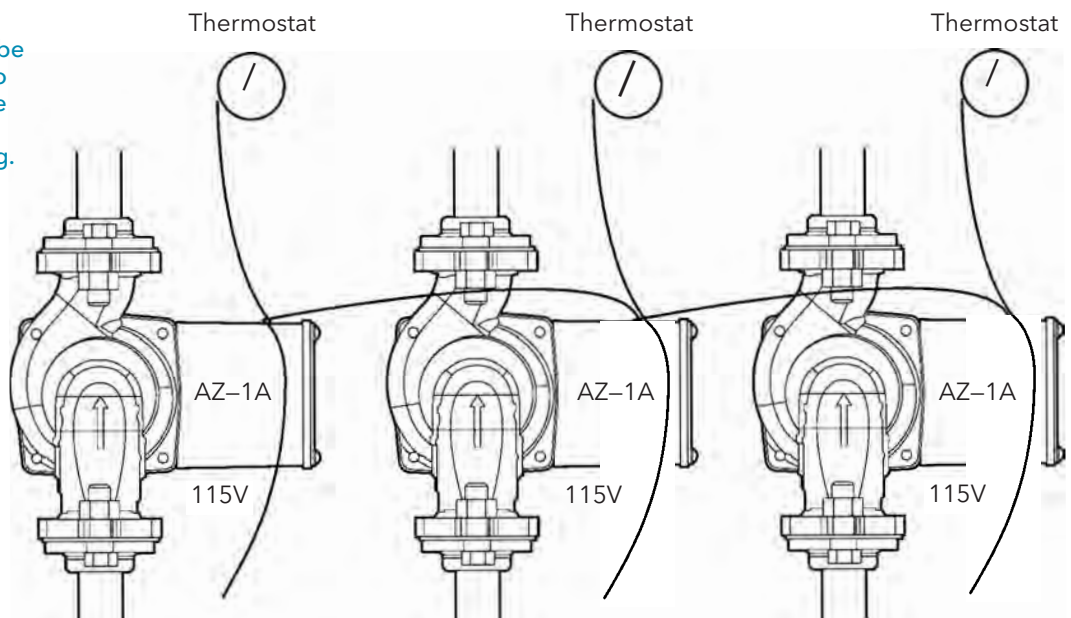

# RELAYS ZONETROL™ Switching Relays for Zoning with Valves

## Features

- 100% factory tested - guarantees operation
- Five year limited warranty - the best in the business
- Replaceable, standard "ice cube" type relays allow up to 10 amps, 1/3 HP per individual zone
- Selectable priority for domestic hot water
- 30 minute built-in priority timer helps prevent house freeze up - no additional plug-in cards required
- Automatically resettable fuse protects controller from overload - eliminates "no heat" call backs due to blown fuse
- Powerful transformers operate up to six zones
- LED diagnostic lights installed internal to the box cover keeps the trouble shooting in the hands of the authorized heating professionals
- Can be used with "tankless coil" or "cold start" applications



## Specifications

Model Number	Part Number	Zones	Priority Feature	Transformer Output at 24 Volts	Relay Switching Action	Each End Switch Contact Rating	Dimension W x H x D (inches)	Approx. Shpg. Wt. (lbs.)
ZTV-4	109407	4	yes	40 VA	DPDT	5A, 1/8 HP @ 120VAC	9-1/4 x 7-1/4 x 2-3/4	4.6
ZTV-6	109408	6	yes	75 VA	DPDT		11-3/8 x 7-1/4 x 3-3/4	6.9

# RELAYS ZONETROL II Switching Relays with Reset Option for Zoning with Pump

## Description

Bell & Gossett's ZoneTrol II is a ready-to-install controller for hydronic circulators in residential and light commercial applications. All ZoneTrol II controllers are UL and cUL listed and feature multi-function LEDs that are visible without removing the cover for easy start-up and troubleshooting. All units are compatible with analog and digital 24 VAC thermostats, including "power stealing" designs. The multi-zone controllers feature an advanced microprocessor design that provides domestic hot water (DHW) priority & timer, pump exercise and a post purge timer without the need for add-on circuit boards or modules.

Four and six zone controllers are field expandable for up to 18 pumps.

## Standard Features (multiple zone controllers only)

- Priority: Enables DHW zone to have priority over heating zones for limited period of time. User adjustable settings include OFF (disables priority functionality), 30 minutes and 60 minutes.
- Post Purge Timer: Circulator(s) will continue to run for 90 seconds after thermostat opens and allows additional extraction of BTUs from high mass boilers. User adjustable settings are OFF and ON.
- Exercise: Runs each circulator for 10 seconds after each 72 hours of inactivity. User adjustable settings are ON and OFF.
- Expandability: 4 and 6 zone controllers can easily be connected via a ZC-11 cable to accommodate systems consisting of up to 18 circulators.
- Five-year Warranty



The next generation of zone controllers from Bell & Gossett brings 21st century technology to residential controls.

## Specifications

Model Number	Part Number	Zones	Combined Load (max.) @ 120 VAC	Dimensions W x L x D Inches (mm)	Weight Lbs (kg)
Z-1	109424	1	5 amps	6.5 x 5 x 3 (165 x 127 x 76)	2.6 (1.18)
Z-2	109425	2	20 amps	6.5 x 5 x 3 (165 x 127 x 76)	3 (1.36)
Z-3	109426	3	20 amps	6.5 x 5 x 3 (165 x 127 x 76)	3.1 (1.4)
Z-4	109427	4	20 amps	13.5 x 8.25 x 3.25 (343 x 210 x 83)	7.3 (3.3)
Z-6	109430	6	20 amps	13.5 x 8.25 x 3.25 (343 x 210 x 83)	7.5 (3.4)
ZC-11*	109454	Communication cable for connection of multiple controllers			0.1 (0.05)

\* fits 4 and 6 zone controllers only – one required for each slave controller.

# VALVES Snap Zone™ Valve

## Description

Snap Zone valves are precision engineered four wire thermoelectrically operated valves designed for heating and cooling systems. The valve opens and closes based upon the voltages applied to the actuator. Use the Bell & Gossett Snap Zone Valves to speed installation time and reduce callback times to customers. The actuator can be installed or removed at any angle on the adapter ring. The compact design and universality in the actuator mounting position allows for easy installation in the most difficult positions.

## Operating Data

Maximum Operating Temperature: 212°F (100°C)  
 Minimum Operating Temperature: 32°F (0°C)  
 Maximum Operating Pressure: 240 PSI  
 Maximum Differential Closeoff: 60 PSI  
 Open/Close Speed: 3 min.  
 Electrical Rating: 24V 60Hz  
 Power Consumption: 1.8W, 75mA (6 per 40VA)  
 End Switch Rating: 1.0A @ 24VAC

## Materials of Construction

Body: Forged Brass  
 Bonnet/Packing Box: Brass  
 Plunger Assembly: Brass, EPDM Seals  
 Stem: Stainless Steel  
 Union Nuts: Brass  
 Tailpieces: Brass  
 O-Rings: EPDM  
 Actuator: Polyamide Housing  
 Cable: PVC

## Cv Ratings

Snap Zone Size	1/2"	3/4"	1"
Cv	1.8	2.8	2.8

Model Number Naming Convention	
SZV	Snap Zone Valve
050	Body Size 050 = 0.500" 075 = 0.750" 100 - 1.000"
N	Connection Type S = Sweat Body N = FNPT Threaded
4W	Actuator Type 4W = 4 Wire
E	End Switch E = Endswitch

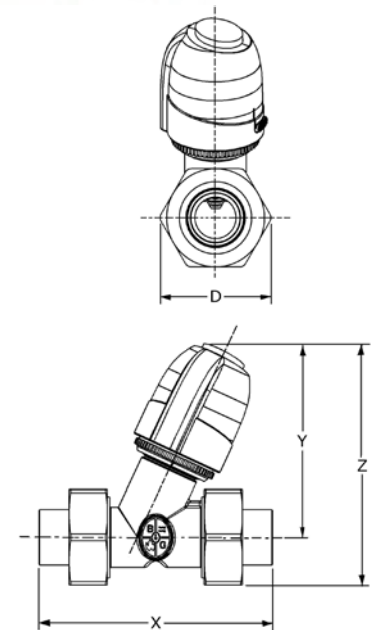
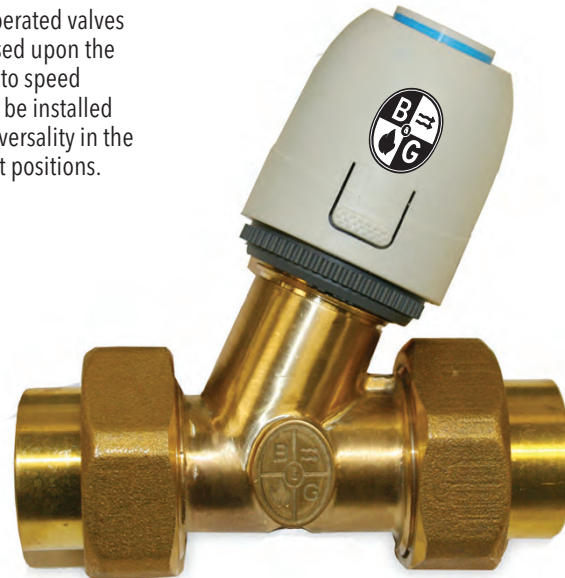

## Specifications

Model Number	Part Number	Description	Dimensions, in inches (mm)				Shipping Weight, lbs (kg)
			D	X	Y	Z	
SZV-050S-4WE	109500	1/2" SWT Zone Valve, 4 Wire	1.59 (40.3)	3.48 (88.5)	3.55 (90.2)	4.24 (107.7)	1.4 (0.6)
SZV-075S-4WE	109501	3/4" SWT Zone Valve, 4 Wire	2.02 (51.3)	4.28 (108.7)	3.55 (90.2)	4.42 (112.5)	1.4 (0.6)
SZV-100S-4WE	109502	1" SWT Zone Valve, 4 Wire	2.24 (56.9)	4.28 (108.7)	3.55 (90.2)	4.52 (114.9)	1.4 (0.6)
SZV-050N-4WE	109506	1/2" NPT Zone Valve, 4 Wire	1.59 (40.3)	3.58 (91.0)	3.55 (90.2)	4.24 (107.7)	1.4 (0.6)
SZV-075N-4WE	109507	3/4" NPT Zone Valve, 4 Wire	2.02 (51.3)	4.18 (106.1)	3.55 (90.2)	4.42 (112.5)	1.4 (0.6)
SZV-100N-4WE	109508	1" NPT Zone Valve, 4 Wire	2.24 (56.9)	4.44 (112.7)	3.55 (90.2)	4.52 (114.9)	1.4 (0.6)
SZV-050S-000	109512	1/2" Sweat Body	1.59 (40.3)	3.48 (88.5)	-	-	1.0 (0.4)
SZV-075S-000	109513	3/4" Sweat Body	2.02 (51.3)	4.28 (108.7)	-	-	1.0 (0.4)
SZV-100S-000	109514	1" Sweat Body	2.24 (56.9)	4.28 (108.7)	-	-	1.0 (0.4)
SZV-050N-000	109515	1/2" NPT Body	1.59 (40.3)	3.58 (91.0)	-	-	1.0 (0.4)
SZV-075N-000	109516	3/4" NPT Body	2.02 (51.3)	4.18 (106.1)	-	-	1.0 (0.4)
SZV-100N-000	109517	1" NPT Body	2.24 (56.9)	4.44 (112.7)	-	-	1.0 (0.4)
SZV-000-4WE	109518	4 Wire Actuator w/ES	-	-	-	-	0.4 (0.2)

# BALANCE VALVES Lead-Free\* Circuit Setter® Plus

## Description

The Circuit Setter Plus and Circuit Setter Plus RF provide the perfect balance of adjustability and efficiency for potable water and HVAC systems. They are precisely calibrated for use as a presettable balance valve, variable orifice flow meter and positive shut-off service valve. They are also designed for optimal system efficiency and water conservation. The Circuit Setter Plus and Circuit Setter Plus RF can provide the perfect balancing solutions for your potable water and HVAC system.

Save time, energy and water with the lead-free Circuit Setter Plus and Circuit Setter Plus RF.

- Designed for all plumbing and HVAC systems.
- Provides equal flow throughout all circuits to conserve water and optimize system efficiency.
- Calibrated accurate flow control and measurement.
- Bi-directional design allows any installation configuration.
- Externally adjustable manual balance valve for easy adjustment.
- Reduces pump energy requirements.
- Meets or exceeds stringent codes for potable water.
- Includes memory stop indicator.
- Provides drain option.
- Provides positive shut off and isolation.
- Includes pressure/temperature ports.

## Materials of Construction

Body: Brass ASTM B283-C69300\*  
 Ball: 304 Stainless Steel  
 Seat Rings: Glass and Carbon filled TFE  
 Readout Valves: Brass with EPT check valves  
 Stem "O" Ring: EPDM

## Maximum Working Pressure

NPT Models: 400 PSIG (2758 kPa)  
 Sweat Models: See table below

## Maximum Operating Temperature

-4°F (-20°C) to 250°F (121°C)

\*CSA certified to NSF/ANSI 372 that product contains less than 0.25% lead content by weight on wetted surface.

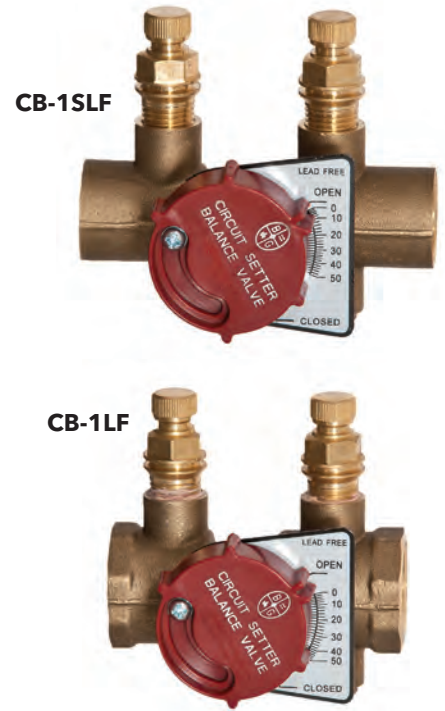

Type Solder	Maximum Pressure Limitations for 1/2" - 1" with Solder Connections	
	Pressure PSI kPa	Temp °F (°C)
95-5 Tin-Antimony	300 (2068)	200 (93)
	250 (1724)	225 (107)
	200 (1379)	250 (121)

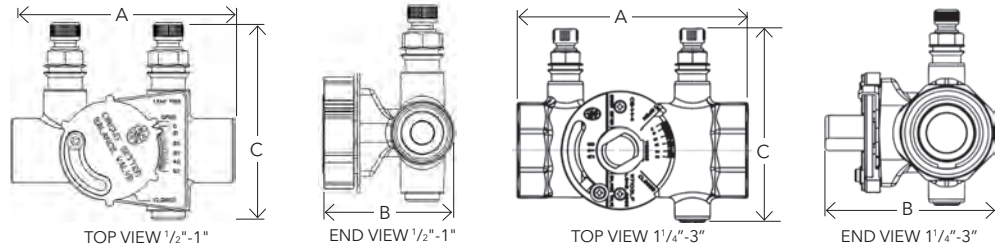

## Specifications

Model Number	Part Number	Size	Connection Type	Dimensions** in Inches (mm)			Weight in lbs. (kg)
				A	B	C	
RF-1/2 LF	117410LF	1/2"	Sweat	2.91 (73.9)	1.82 (46.2)	2.85 (72.4)	0.6 (0.27)
RF-3/4 LF	117411LF	3/4"	Sweat	3.51 (89.2)	2.05 (52.1)	3.10 (78.7)	0.75 (0.34)
CB-1/2 LF	117412LF	1/2"	Sweat	2.91 (73.9)	1.82 (46.2)	2.85 (72.4)	1 (0.45)
CB-3/4 LF	117413LF	3/4"	Sweat	3.51 (89.1)	2.05 (52.1)	3.10 (78.7)	1.25 (0.6)
CB-1S LF	117401LF	1"	Sweat	4.29 (109)	2.33 (59.2)	3.33 (84.6)	2 (0.91)
CB-1 1/4 LF	117402LF	1 1/4"	Sweat	4.91 (124.7)	3.08 (78.2)	3.69 (93.7)	3.5 (1.6)
CB-1 1/2 LF	117403LF	1 1/2"	Sweat	5.21 (132.3)	3.27 (83)	3.95 (100.3)	3.8 (1.7)
CB-2S LF	117404LF	2"	Sweat	6.31 (160.3)	3.83 (97.3)	4.44 (112.8)	6.2 (2.8)
CB-1/2 LF	117414LF	1/2"	NPT	2.94 (74.7)	1.98 (50.3)	3.02 (76.7)	1.25 (0.6)
CB-3/4 LF	117415LF	3/4"	NPT	3.06 (77.7)	2.17 (55.1)	3.12 (79.2)	1.5 (0.7)
CB-1 LF	117416LF	1"	NPT	3.81 (96.8)	2.47 (62.7)	3.42 (86.9)	2 (0.9)
CB-1 1/4 LF	117103LF	1 1/4"	NPT	4.41 (112)	3.19 (81)	3.69 (93.7)	3.5 (1.6)
CB-1 1/2 LF	117104LF	1 1/2"	NPT	4.42 (112.3)	3.37 (85.6)	3.95 (100.3)	3.8 (1.7)
CB-2 LF	117105LF	2"	NPT	5.13 (130.3)	3.98 (101.1)	4.44 (112.8)	6.2 (2.8)
CB-2 1/2 LF	117106LF	2 1/2"	NPT	6.00 (152.4)	4.51 (114.6)	4.83 (122.7)	9 (4.1)
CB-3 LF	117107LF	3"	NPT	6.50 (165.1)	5.12 (130.0)	5.44 (138.2)	12 (5.4)

\*\* All dimensions +/-0.125 (3.2 mm) tolerance. Dimensions are subject to change. Not to be used for construction purposes unless certified.

# BALANCE VALVES Circuit Sentry™ Flo-Setter™ II

## Description

The Circuit Sentry Flo-Setter II valve is a field adjustable pressure independent flow limiter that maintains set flow rates regardless of pressure fluctuations in the system; eliminates overflow.

- The unique **GPM dial** is easy to set.  
Requires no instruments, charts or wheels
- Saves pump energy and improves coil efficiency
- No minimum straight pipe lengths required
- Integrated pressure /temperature ports included
- Large open flow paths for clog-free operation
- Integrated isolation/shut-off capability

## Materials of Construction

Body: Brass (1/2" - 1-1/4")

Ductile Iron (1-1/2" - 2")

Flow Setting: PA6 20% Glass

Spring: Stainless Steel

Diaphragm: HNBR

O-Rings: EPDM

## Maximum Working Pressure

375 PSIG (2585 kPa)

## Maximum Operating Temperature

14°F (-10°C) to 248°F (110°C)

## Control Range

Maximum 58 PSI (399 kPa) Delta P

## Accuracy

+/- 5%

## Model AF



## Model AF Specifications (includes union tailpiece)

Model Number	Valve Size Fixed End	Connection Fixed End	DIMENSIONS* IN INCHES (mm)						Flow Capacity in GPM (L/hr)		Approx. Weight lbs. (kg)
			B	C	D**	E**	G Max***	T Max***	Min.	Max.	
AF-1/2	1/2"	Sweat Female	5.6 (144)	3.4 (87)	2.24 (57)	1.12 (28)	5.6 (142)	1.55 (39)	0.26 (60)	4.75 (1,080)	1.2 (0.5)
		NPT Female	5.6 (144)	3.4 (87)	2.24 (57)	1.12 (28)	5.0 (127)	1.55 (39)	0.26 (60)	4.75 (1,080)	1.2 (0.5)
AF-3/4	3/4"	Sweat Female	5.6 (144)	3.4 (87)	2.24 (57)	1.12 (28)	6.3 (160)	1.55 (39)	0.45 (102)	8.50 (1,930)	1.5 (0.7)
		NPT Female	5.6 (144)	3.4 (87)	2.24 (57)	1.12 (28)	5.3 (135)	1.55 (39)	0.45 (102)	8.50 (1,930)	1.5 (0.7)
AF-1	1"	Sweat Female	6.8 (173)	4.3 (110)	2.54 (65)	1.27 (33)	7.6 (193)	2.00 (51)	0.60 (136)	10.56 (2,400)	3.1 (1.4)
		NPT Female	6.8 (173)	4.3 (110)	2.54 (65)	1.27 (33)	6.4 (163)	2.00 (51)	0.60 (136)	10.56 (2,400)	3.1 (1.4)
AF-1-1/4	1 1/4"	Sweat Female	7.0 (178)	4.3 (110)	2.54 (65)	1.27 (33)	7.9 (201)	2.00 (51)	0.88 (200)	22.01 (5,000)	3.6 (1.6)
		NPT Female	7.0 (178)	4.3 (110)	2.54 (65)	1.27 (33)	6.7 (170)	2.00 (51)	0.88 (200)	22.01 (5,000)	3.6 (1.6)
AF-1-1/2	1 1/2"	Sweat Female	7.9 (201)	5.1 (131)	3.60 (92)	1.8 (46)	10.6 (269)	2.52 (64)	3.17 (719)	32.58 (7,400)	7.6 (3.4)
		NPT Female	7.9 (201)	5.1 (131)	3.60 (92)	1.8 (46)	9.2 (234)	2.52 (64)	3.17 (719)	32.58 (7,400)	7.6 (3.4)
AF-2	2"	Sweat Female	8.1 (207)	5.1 (131)	3.6 (92)	1.80 (46)	11.7 (297)	3.14 (80)	3.96 (900)	45.57 (10,350)	8.7 (3.9)
		NPT Female	8.1 (207)	5.1 (131)	3.6 (92)	1.80 (46)	9.7 (246)	3.14 (80)	3.96 (900)	45.57 (10,350)	8.7 (3.9)

\*All dimensions +/- 0.125" (3.2 mm) tolerance. Dimensions are subject to change. Not to be used for construction purposes unless certified.

\*\*Dimension is of maximum width of the handle or body, whichever is greater.

\*\*\*Includes tailpiece. Measurement of maximum length tailpiece available.

For minimum differential requirements please refer to submittal A-611 on our website. Maximum differential pressure is 58 PSID.

Minimum temperature is 14°F (-10°C) to 248°F (120°C). Maximum operating pressure is 375 PSI.

**NOTE: Model AF valves are configured valves and therefore have no part numbers. They include union tail pieces and can be selected to include optional ball isolation/shut-off valve.**

## New GPM dial



## Circuit Sentry Flo-Setter II

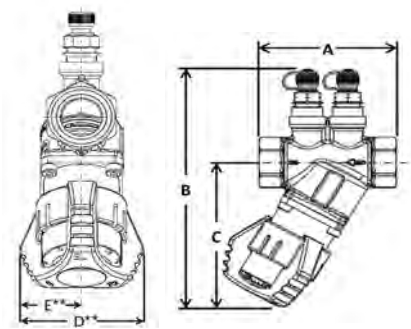

## Circuit Sentry Flo-Setter II Specifications

Model Number	Part Number	Size	Connection Type	DIMENSIONS* IN INCHES (mm)					Flow Capacity in GPM (L/hr)		Approx. Weight lbs. (kg)
				A	B	C	D**	E**	Min.	Max.	
FS-1/2	117630	1/2"	NPT Female	2.9 (75)	5.6 (144)	3.4 (87)	2.24 (57)	1.12 (28)	0.26 (60)	4.75 (1,080)	1.1 (0.5)
FS-3/4	117632	3/4"	NPT Female	3.1 (79)	5.6 (144)	3.4 (87)	2.24 (57)	1.12 (28)	0.45 (102)	8.50 (1,930)	1.3 (0.6)
FS-1	117643	1"	NPT Female	3.9 (100)	6.8 (173)	4.3 (110)	2.54 (65)	1.27 (33)	0.60 (136)	10.56 (2,400)	2.8 (1.3)
FS-1-1/4	117636	1 1/4"	NPT Female	4.0 (104)	7.0 (178)	4.3 (110)	2.54 (65)	1.27 (33)	0.88 (200)	22.01 (5,000)	3.1 (1.4)
FS-1-1/2	117637	1 1/2"	NPT Female	5.4 (138)	7.9 (201)	5.1 (131)	3.60 (92)	1.80 (46)	3.17 (719)	32.58 (7,400)	6.6 (3.0)
FS-2	117638	2"	NPT Female	5.4 (138)	8.1 (207)	5.1 (131)	3.60 (92)	1.8 (46)	3.96 (900)	45.57 (10,350)	7.5 (3.4)

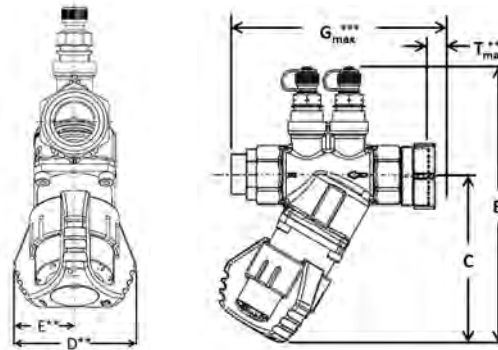

# VALVES Flo-Control™ Valves

## Description

Flo-Control valves prevent gravity flow in forced hot water systems, and permit summer/winter operation of indirect water heaters.

## Features

- Combination straight/angle configurations in sizes 3/4" to 2" for ease of installation.
- Removable cap allows easy cleaning and service without removing pipe connections.
- Manual operating position for vertical lift disc to permit gravity circulation.

## Operating Data

Maximum Working Pressure: 125 PSIG (862 kPa)  
Maximum Operating Temperature: 250°F (121°C)



Angle Pattern  
2-1/2", 3"



Straight-Angle Pattern  
3/4", 1", 1-1/4", 1-1/2", 2"



Bronze Straight  
Pattern 3/4"



Straight Pattern  
2-1/2", 3", 4"

## Specifications

Model Number	Part Number	Dimension in Inches (mm)					Approx Shpg. Wt. lbs. (Kg)
		A	B	C	D	E	
SA 3/4	107034	3 1/8 (79)	4 15/16 (125)	1 5/8 (41)	1 9/16 (40)	1 7/16 (37)	2 (0.9)
SA 1	107018	3 1/2 (89)	5 1/2 (140)	1 7/8 (48)	1 3/4 (44)	1 1/2 (38)	3 (1.4)
SA 1 1/4	107019	4 (102)	6 1/2 (165)	2 1/4 (57)	1 31/32 (50)	1 7/8 (48)	4 (1.8)
SA 1 1/2	107020	5 (127)	7 1/4 (184)	3 (76)	2 1/2 (64)	2 1/4 (57)	8 (3.6)
SA 2	107021	6 7/8 (175)	7 1/2 (191)	4 5/8 (117)	4 (102)	2 5/8 (67)	12 (5.5)
A 2 1/2	107006	7 1/4 (184)	7 5/8 (194)	5 3/8 (137)	4 1/2 (114)	4 1/8 (105)	20 (9.1)
A 3	107007	7 1/2 (191)	7 3/4 (197)	6 (152)	4 1/2 (114)	4 1/4 (108)	23 (10.5)
S 2 1/2	107014	9 5/16 (237)	8 11/16 (221)	5 3/8 (137)	4 3/4 (121)	2 11/16 (68)	22 (10.0)
S 3	107015	9 15/16 (252)	9 (229)	6 (152)	5 1/4 (133)	3 (76)	24 (10.9)
S 4	107004	13 (330)	12 1/2 (318)	7 3/4 (197)	7 (178)	3 7/8 (98)	58 (26.4)
SB 3/4	107024	3 1/4 (83)	3 7/8 (98)	1 7/16 (37)	1 5/8 (41)	23/32 (18)	1.2 (0.6)

Dimensions are approximate and subject to change. Contact factory for certified dimensions.

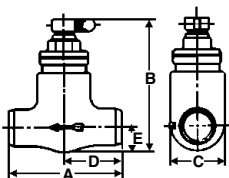

Sizes 3/4"  
Bronze Straight Valve

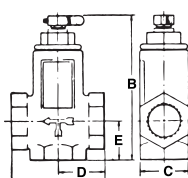

Sizes 3/4", 1", 1-1/4", 1-1/2"  
Straight Angle Valves

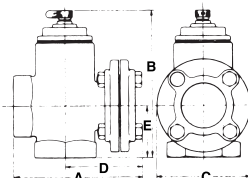

Sizes 2"  
Straight Angle Valves

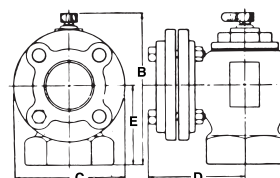

Sizes 2-1/2", 3"  
Angle Valves

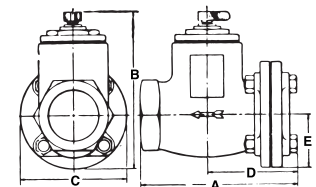

Sizes 2-1/2", 3", 4"  
Straight Valves

# VALVES Hydrotol™ Flow Control Valves

## Description

The Hydrotol (HT) flow control valve is used to prevent overheating of zones due to gravity flow in hydronic heating systems and will permit summer-winter operation of indirect water heater. The HT valve allows fluid to pass when the system or zone pumps start. When the system or zone pumps are not operating, the HT valve remains closed, preventing gravity circulation. The HT valves are designed with a 1/2 turn knob that can be manually opened when draining the system or for bypass purposes. The HT valve can be installed in either the horizontal or vertical orientation.



## Operating Data

Maximum Working Pressure: 150 PSI (10 bar)  
 Maximum Operating Temperature: 250°F (121°C)

## Materials of Construction

Body: Brass  
 Internal Components: Non-Ferrous

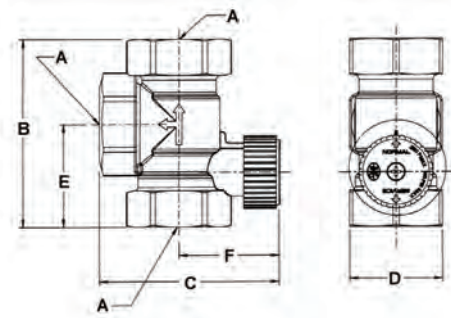

## Specifications

Model Number	Part Number	Dimensions — Inches (mm)						Approx. Shpg. Wt. lbs. (Kg)
		A	B	C	D	E	F	
HT-3/4	107035	3/4" NPTF	3-3/16" (82)	3" (76)	1-9/16" (40)	1-3/4" (44)	1-11/16" (43)	1.3 lbs. (0.6)
HT-1	107037	1" NPTF	3-5/8" (93)	3-3/16" (82)	1-9/16" (40)	1-15/16" (50)	1-11/16" (43)	1.2 lbs. (0.5)
HT - 1-1/4	107038	1-1/4" NPTF	4" (101)	3-11/16" (93)	1-11/16" (43)	2-1/4" (57)	1-7/8" (48)	1.8 lbs. (0.8)

Do not use for construction. Dimensions are approximate and subject to change. Contact factory for certified dimensions.

# VALVES DB-Differential Bypass Valve

## Description

The differential bypass valve is used in systems where heating loads may be excluded from the circuit as zone valves close. It controls the excess flow in the system by acting as a bypass while ensuring adequate flow to the remaining open circuits. The differential bypass valve helps reduce velocity noise caused by excess flow through the circuits while maintaining the pump head at a constant value.

For hydronic systems utilizing zone valve

- Controls excess flow in the system when there is reduction in demand
- Available in 3/4" connection
- All brass body with non-ferrous internals

## Operating Data

Maximum Working Pressure: 150 PSIG (1,034 kPa)  
 Maximum Operating Temperature: 230°F (110 °C)  
 Adjustment Range: 2 to 10 PSI

## Materials of Construction

Valve Body: Brass  
 Seals: EPDM  
 Spring: Stainless Steel  
 Knob: ABS

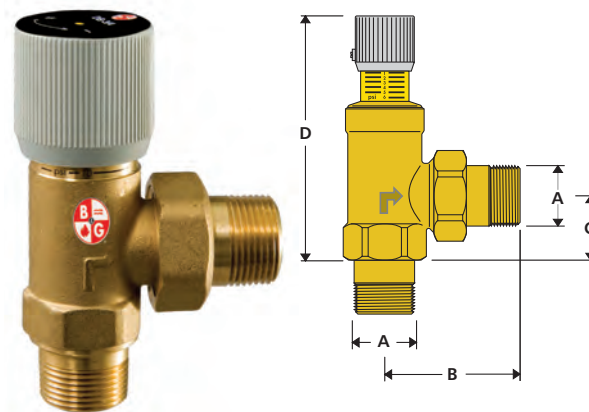

## Specifications

Model Number	Part Number	A (mm)	B (mm)	C (mm)	D (mm)	Connection Type	Weight (LB)
DB-3/4	113247	3/4" (19)	2-5/16" (59)	1" (26)	4" (104)	M NPT	1

# VALVES Pressure Reducing Valves

## Description

Reducing valves fill the system to a preset pressure for optimum performance.

## Features

- Fast fill feature reduces start-up time and labor.
- Low inlet pressure check valve helps prevent loss of system pressure if the supply water drops below system pressure.
- Convenient cleanable strainer is designed to prevent dirt and sediment from entering the system.
- Union connection available with 1/2" male NPT thread and 1/2" female sweat tail-piece for fast, flexible system connection.
- Lead-Free brass body construction is ideal for potable water systems.

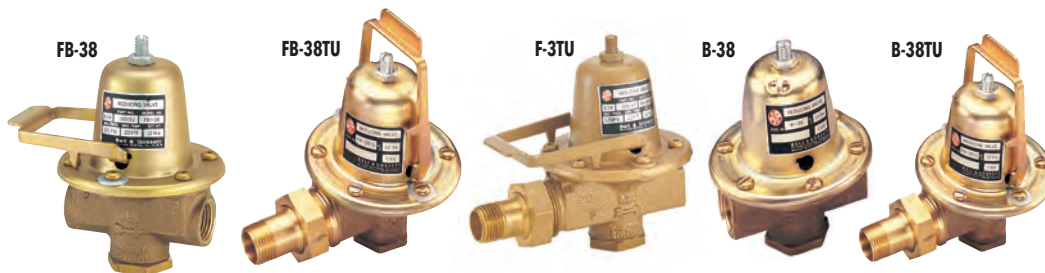

## Specifications for Combination "Dual Units"

Model Number	Part Number	Component Valves	Body Material	Connection in Inches		Dimensions in Inches (mm)		Approx. Shpg. Wt. lbs. (Kg)
				Boiler	Fill	Between Connections	Overall Height	
8	110199LF	Relief B-38	Lead-Free Brass	1/2 NPT	1/2 NPT	6 7/16 (164)	5 3/8 (137)	4 (1.8)
F-3	110197LF	Relief FB-38			1/2 NPT	6 7/16 (164)	6 (152)	3 3/4 (1.7)
F-3TU	110198LF	Relief FB-38TU			1/2 Union NPT/Sweat	8 5/8 (219)		4 (1.8)

PRESSURE SETTING:

Relief 30 PSI  
Reducing 12 PSI standard; field adjustable range: 10 - 25 PSI  
**Maximum operating temperature 225°F (107°C) - Maximum operating pressure 125 PSIG (862 kPa)**

\*CSA certified to NSF/ANSI 372 that product contains less than 0.25% lead content by weight on wetted surface.

Models ending in TU feature 1/2" sweat/NPT union connection.

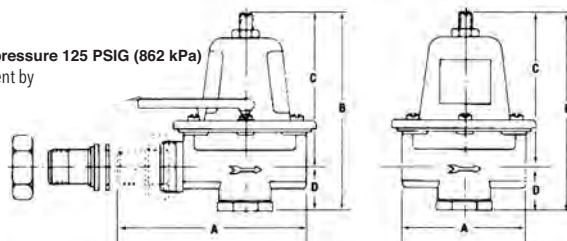

## Specifications for Pressure Reducing Valve

Model Number	Part Number	Body Material	Connection Size - Inches		Factory Setting (PSIG)	Adjustable Range (PSIG)	Dimensions in Inches (mm)				Approx. Shpg. Wt. lbs. (Kg)
			A	B			C	D			
B-38	110190LF	Lead-Free Brass	1/2	NPT	12	10 - 25	3 1/16 (78)	4 13/16 (122)	3 11/16 (94)	1 1/8 (29)	1 3/4 (0.8)
B7-12	110196LF		3/4				3 (76)	4 31/32 (126)	3 21/32 (93)	1 5/16 (33)	2 1/4 (1.0)
B-38TU	110191LF		1/2	Union*			4 31/32 (126)	4 13/16 (122)	3 11/16 (94)	1 1/8 (29)	2 (0.9)
FB-38	110192LF		1/2	NPT			3 1/16 (78)				1 3/4 (0.8)
FB-38TU	110193LF		1/2	Union*			4 31/32 (126)				2 (0.9)
6	110194LF		1/2	NPT			45	25 - 60	3 1/16 (78)	4 31/32 (126)	3 21/32 (93)
7	110195LF	3/4	3 (76)		2 1/4 (1.0)						

\* Models ending in "TU" feature 1/2" sweat/NPT union connection

# ASME Safety Relief Valves

## Description

ASME Safety Relief Valves protect fired and unfired hot water vessels against hazardous operating pressures.

## Features

- Engineered in accordance with Section IV of the ASME boiler and pressure code for heating boilers with capacities certified by the National Board of Boiler and Pressure Vessel Inspectors.
- Offer the highest BTUH ratings available on the market today for valves in their class (790,000 to 5,999,000 BTUH)
- EPDM diaphragm operated (cast iron models) and diaphragm assisted (bronze models) have an effective area approximately 5 times greater than conventional "pop-type" relief valves to help overcome the effects of fouling.
- Low differential between opening and closing pressures helps to prevent conditions under which system water might flash to steam and cause hammering.



Nos. 3301 & 4100



Nos. 790 & 1170

Models 3301 & 4100 Iron Body Valves

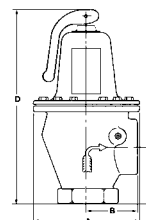

Models 790 & 1170 Bronze Body Valves

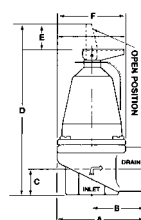

Size, Capacity & Relief Setting for B&G ASME Safety Relief Valves <sup>1</sup>				
Relief Setting PSIG	Model Number Capacity in BTU Per Hour			
	Iron Body		Bronze Body	
30	3301-30	4100-30	790-30	1170-30
	3,300,000	4,100,000	790,000	1,170,000
36	3301-36	4100-36	790-36	1170-36
	3,800,000	4,600,000	900,000	1,330,000
45	3301-45	4100-45	790-45	1170-45
	4,500,000	5,515,000	1,065,000	1,575,000
50	3301-50	4100-50	790-50	1170-50
	4,900,000	5,990,000	1,160,000	1,710,000
75	NOT AVAILABLE		790-75	1170-75
			1,615,000	2,385,000
100	NOT AVAILABLE		790-100	1170-100
			2,075,000	3,060,000
125	NOT AVAILABLE		790-125	1170-125
			2,535,000	3,735,000

<sup>1</sup> Contact your local wholesaler or Bell & Gossett representative for availability of ASME Safety Relief Valves with special pressure settings.

## Specifications

Model Number	Body	NPT Connections in Inches		Dimension in Inches (mm)						Approx Shpg. Wt. lbs. (Kg)
		Inlet	Outlet	A	B	C	D	E	F	
790	Bronze	3/4	3/4	2 9/16 (65)	1 1/2 (38)	3/4 (19)	4 9/16 (116)	1 1/32 (26)	2 3/32 (53)	1.2 (0.5)
1170		1	1	2 7/8 (73)	1 3/4 (44)	7/8 (22)	4 15/16 (125)		2 1/4 (57)	1.5 (0.7)
3301	Iron	1 1/2	2	6 (152)	2 7/8 (73)	3 1/4 (83)	11 (279)	N/A	17 (7.7)	
4100										

Actual unit model numbers include individual valve pressure settings as a suffix to the basic valve model number noted. Dimensions are approximate and subject to change. Contact factory for certified dimensions.

Maximum Operating Temperature: 250°F (121°C) - Maximum Working Pressure: Model 790 & 1170: 125PSIG (862KPa); Model 3301 & 4100: 50 PSIG (345 KPa).



# ACCESSORIES Copper Red Ring Monoflo® Fittings

## Description

Copper Red Ring Monoflo Fittings let you use a single pipe to serve as both supply and return main.

## Features

- Connect risers to the main, assuring proper diversion of water to each heating unit regardless of type and its position in the system.
- Recommended for most installations including cast iron non-ferrous base boards, free-standing radiation or convectors.
- Only one fitting is needed for most installations for adequate diversion for upfeed radiation. For most applications, a second fitting can be used if higher resistance is required.

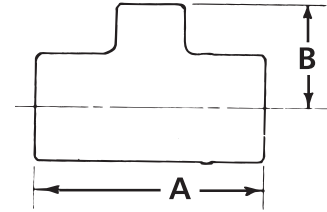

## Operating Data

Maximum Working Pressure: 150 PSIG (1,034 kPa)  
Maximum Operating Temperature: 300°F (149°C)

## Specifications

Part Number	Size Inches	Dimensions-Inches (mm)*		Cv Ratings**		Approx. Shpg. Wt. lbs. (Kg)
		A	B	1 FTG	2 FTG	
108119	3/4 x 1/2***	2-7/32 (56)	1 (25)	4.2	—	1/4 (0.1)
108120	1 x 1/2	2-9/16 (65)	1-5/32 (30)	14.5	8.7	1/2 (0.2)
108121	1 x 3/4	2-3/4 (70)	1-3/8 (35)			
108122	1-1/4 x 1/2	2-3/4 (70)	1-7/32 (31)	24.0	15.5	
108123	1-1/4 x 3/4	2-27/32 (72)	1-3/8 (35)	39.0	25.0	1-1/4 (0.6)
108124	1-1/2 x 3/4	3-3/32 (78)	1-11/16 (42)			
108125	1-1/2 x 1	3-3/8 (86)	1-11/16 (42)	80.0	55.0	1-3/4 (0.8)
108126	2 x 3/4	3-1/2 (89)	1-27/32 (47)			
108127	2 x 1	3-13/16 (97)	2-1/32 (52)			

\* Do not use for construction. Dimensions are approximate and subject to change. Contact factory for certified dimensions.

\*\* With Side Branch plugged.

\*\*\* Return only.

# AIR SEPARATORS In-Line Air Separator

## Description

The B&G In-Line Air Separator is specifically designed to efficiently separate air from circulating water in hydronic heating and cooling systems to assure a quiet operation.

## Operating Data

Maximum Working Pressure: 175 PSIG (1,207 kPa)  
Maximum Operating Temperature: 300°F (149°C)

## Materials of Construction

One Piece Cast Iron

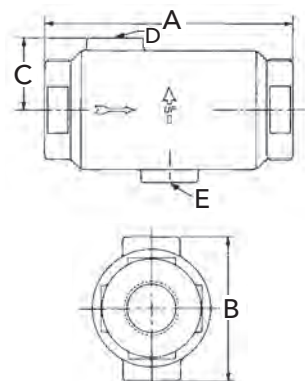

## Specifications

Model Number	Part Number	Size NPT	Max Flow (GPM)	Dimensions – Inches (mm)					Approx. Shpg. Wt. (Lbs)
				A	B	C	D	E	
IAS -1	112118	1"	15	6-1/8	3-1/2	1-3/4	1/8 NPT		3-3/4
IAS - 1-1/4	112119	1-1/4"	25	(156)	(89)	(45)			3-1/2
IAS - 1-1/2	112097	1-1/2"	35	8-1/8	4-1/2	2-1/4	3/4 NPT	1/2 NPT	8-1/2
IAS - 2	112098	2"	50	(207)	(114)	(57)			7-1/2
IAS - 2-1/2	112099	2-1/2"	75	10-1/8	6-3/8	3-3/16			23
IAS - 3	112100	3"	125	(257)	(257)	(81)			21-1/2

Dimensions are approximate and subject to change. Contact factory for certified dimensions.

# AIR SEPARATORS EASB-Jr Enhanced Air Separator

## Description

Bell & Gossett's Model EASB-JR Enhanced Air Separator automatically removes entrained air bubbles in hydronic systems. As fluid enters the EASB-JR, the velocity is decreased creating a low pressure area. The small bubbles are released from fluid and then collected on the coalescing medium. As the bubbles coalesce, they rise to the top of the air separator where they are released to atmosphere through the built-in automatic air vent. The air separator has a bottom 1/2" NPT connection to accommodate a B&G diaphragm expansion tank. The compact design and brass body construction make the EASB-JR ideal for residential and commercial hydronic heating systems.

## Operating Data

Maximum Working Pressure: 150 PSI (10 bar)  
Maximum Operating Temperature: 250°F (121°C)

## Materials of Construction

Body & Cap: Brass  
Coalescing Medium: Stainless Steel  
Venting Mechanism: Non-Ferrous

## Specifications

Model Number	Part Number	Size	Dimension in Inches (mm)						Approx. Shpg. Wt. Lbs. (Kg)
			A	B	C	D	E	F	
EASB-3/4 JR	112111	3/4" NPT	67/8 (175)	15/8 (41)	113/16 (46)	35/8 (92)	21/4 (57)	3/4" NPTF	2.5 (1)
EASB-3/4S JR	112114	3/4" Sweat	67/8 (175)	15/8 (41)	113/16 (46)	35/8 (92)	21/4 (57)	3/4" Sweat	2.5 (1)
EASB-1 JR	112112	1" NPT	67/8 (175)	15/8 (41)	113/16 (46)	35/8 (92)	21/4 (57)	1" NPTF	2.5 (1)
EASB-1S JR	112115	1" Sweat	67/8 (175)	15/8 (41)	113/16 (46)	35/8 (92)	21/4 (57)	1" Sweat	2.5 (1)
EASB-11/4 JR	112113	11/4" NPT	71/2 (191)	17/8 (48)	25/16 (59)	45/8 (117)	31/8 (79)	11/4" NPTF	4 (1.8)
EASB-11/4S JR	112116	11/4" Sweat	71/2 (191)	17/8 (48)	25/16 (59)	45/8 (117)	31/8 (79)	11/4" Sweat	4 (1.8)
EASB-11/2 JR	112117	11/2" NPT	71/2 (191)	17/8 (48)	25/16 (59)	45/8 (117)	31/8 (79)	11/2" NPTF	4 (1.8)
EASB-2 JR	112464	2" NPT	71/2 (191)	2 (51)	21/2 (64)	5 (127)	31/8 (79)	2" NPTF	5 (2.3)

Dimensions are approximate and subject to change. Contact factory for certified dimensions.



## Dimensions & Weights

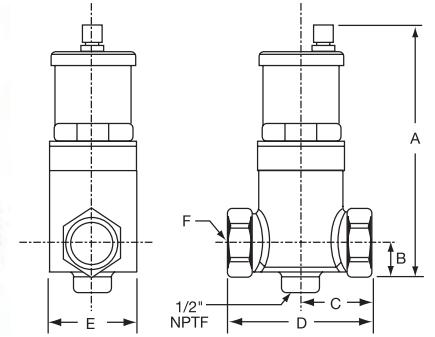

# Enhanced Air Separator

## Description

Bell & Gossett's Model EAS Enhanced Air Separator is a patented, innovative design in air separators. It has been engineered to remove entrained air from hydronic heating and cooling systems providing far superior air removal compared with other devices available today. The EAS is ideal for residential, institutional and light commercial applications.

## Specifications

Model Number	Part Number	Max. Flow (GPM)	Size Inches NPT	Dimensions — inches (mm)					Approx. Shpg. Wt. Lbs. (Kg)
				A	B	C	D	E	
EAS-1	112105	35	1	12-3/16 (310)	6-7/8 (175)	6-7/16 (164)	3-15/16 (100)	3 (76)	8.8 (4)
EAS-1	112106	35	1-1/4	12-3/16 (310)	6-7/8 (175)	6-7/16 (164)	3-15/16 (100)	3 (76)	8.4 (3.8)
EAS-1	112107	45	1-1/2	15-3/4 (400)	11-3/8 (289)	8-5/8 (219)	4-7/8 (124)	4-1/4 (108)	15.5 (7)
EAS-2	112108	70	2	17-1/2 (445)	11-3/8 (289)	8-5/8 (219)	4-7/8 (124)	4-1/4 (108)	15.25 (6.9)

EAS-1 or EAS- 1-1/4 Max. Width 4-1/16" (103mm)

EAS- 1-1/2 or EAS-2 Max. Width 5-3/4" (146mm)

## Operating Data

Maximum Working Pressure: 150 PSI (10.3 bar)  
Maximum Operating Temperature: 250°F (121°C)

## Materials of Construction

Body & Cap: Cast Iron  
Internals: Stainless Steel  
3/4" Large Capacity Air Vent: Brass Body Nonferrous Internals

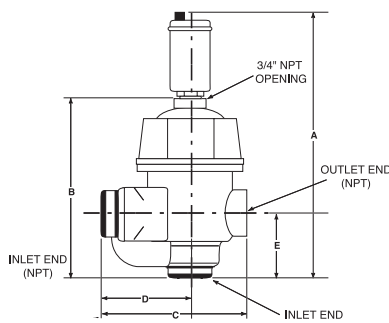

## How It Works

- As system fluid enters through the inlet, (either straight or angle) the diffuser distributes flow evenly across the stainless steel, wire brush-like medium.
- Air bubbles, even micro air bubbles, stick to the brush filaments.
- Trapped air rises above the diffuser through a baffle (not pictured), where the air is then released through an opening on top.
- Deaerated water then goes back into the system.

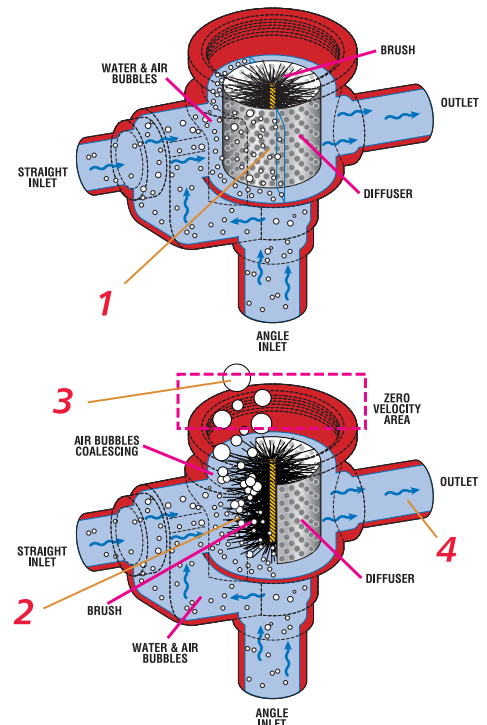

# HYDRONIC SPECIALTIES

## RV-125A Readout Valve and RP-250B Readout Probe

The RV-125A is designed for use wherever pressure tapings are required to monitor flow or pressures. The Readout Valve is fitted with an EPT insert which incorporates a unique check valve feature designed to check flow when the Readout Valve is not being used to monitor flow. Use companion RP-250B Readout Probes with the RV-125A Readout Valve. **300 PSIG Working Pressure – 250°F Maximum Operating Temperature**



## TB- Thermoflo® Balancer

A device for instant visual balancing of hot or cold water flows. With a B&G Thermoflo balancer installed in each circuit or zone, the entire system can be quickly balanced to meet original design calculation. No. TB-3/4"- Capacity 1 to 5 GPM. No. TB-1"- Capacity 2 to 10 GPM. **125 PSIG Working Pressure – 250°F Maximum Operating Temperature**



## DT-2 Drain-O-Tank® Air Charger

The Drain-O-Tank Air Charger offers a sure, quick way to recharge a water-logged compression tank. **125 PSIG Working Pressure – 240°F Maximum Operating Temperature**



# AIR VENTS

## Model No. 107A High Capacity Air Vent

A rugged High Capacity Air Vent designed to purge free air from liquid systems at **operating pressures up to 150 PSIG**. The Model 107A Air Vent has a cast iron body and bonnet, with stainless steel, brass and EPDM internal components and is suitable for a **maximum operating temperature of 250°F**. The Air Vent has a 3/4" NPT inlet and 3/8" NPT outlet.



## No. 97 Automatic Air Vent

A float type vent designed to vent troublesome air from hydronic heating systems. The brass body and the non-ferrous internals provide years of reliable service. The compact design (3-1/8" x 1-7/8") and high operating pressure/temperature (**240°F @ 150 PSIG**) limitations make the No. 97 a must in any hydronic heating system.



## No. 26 Vacuum Breaker

Designed to protect closed vessels and piping systems against collapse when the induced vacuum exceeds design conditions. When used on steam heating systems, the No. 26 Vacuum Breaker controls induced vacuum, permitting normal return of condensate to the boiler. Adjustable range 1/4" to 20" (mercury) vacuum. Factory set to 4" – **240 PSIG Maximum Working Pressure – 300°F Maximum Operating Temperature**



## No. 98

A high capacity automatic air vent that is designed to remove air in closed loop systems. Materials of construction: Brass body with non-ferrous internals. **Maximum Working Pressure: 150 PSI. Maximum Operating Temperature: 250°F**



## No. 87, 67 and 7 Automatic Air Vents

Designed to vent the accumulation of troublesome air wherever it can be trapped. These non-ferrous automatic air vents are 4-3/4" x 2-1/4", 3-3/16" x 1-1/2" and 4-1/16" x 2-3/16" (height and width), respectively, and are rated for a **maximum operating temperature of 240°F at pressures of 150, 35 and 75 PSI, respectively**. The No. 87 has a combination of 1/2" FPT/3/4" MPT connection, whereas No's. 67 and 7 have 1/8" MPT, and FPT connections.



## No. 4V "Coin-Operated" Air Vent

Specially designed for the new types of radiators. An important feature is that it projects only slightly, being almost flush with the radiator. **150 PSIG Working Pressure – 250°F Maximum Operating Temperature**



## Specifications

Model Number	Part Number	Description	System Connection	Dimensions (W x H)	Maximum		Approx. Shpg. Wt. (Lbs) Carton Of	
					Pressure	Temperature		
98	113246	Automatic Air Vent	3/4" NPTM	4-1/2" x 9-5/8"	150 PSIG	250°F	1	.8
97	113222		1/8" NPTM	1-7/8" x 3-1/8"			1	.8
87	113021		Combination 3/4" NPTM 1/2" NPTF	2-1/4" x 4-3/4"			1	.61
67	113020		1/8" NPTM	1-1/2" x 3-3/16"	35 PSIG	.25		
7	113001		1/8" NPTF	2-3/16" x 4-1/16"	75 PSIG	.5		
107A	113076	High Capacity Air Vent	3/4" NPTF	4-1/2" x 9-5/8"	150 PSIG	250°F	1	10
4V	113055	Manual Air Vent	1/8" NPTM	5/8" x 5/8"	150 PSIG	250°F	48	2
26	113075	Vacuum Breaker	3/4" NPTM	1-1/4" x 3"	240 PSIG	300°F	6	3
RV-125A	113100	Readout Valve	1/8" NPTM	1-1/8" x 9/16"	300 PSIG	250°F	50 pairs	4
1/4" P/T	V58050PK	Readout Valve	1/4" NPTM	1-1/4" x 1-1/4"	300 PSIG	250°F	1	.1
1/8" P/T	G97030	Readout Valve	1/8" NPTM	1-1/8" x 1-1/4"	300 PSIG	240°F	1	.5
RP-250B	113102	Readout Probe	N/A	2" x 5/8"	300 PSIG	250°F	6 pairs	1
DT-2	113041	Drain-O-Tank	1/2" NPTM	2-1/4" x 6-5/16"	125 PSIG	240°F	1	.67
TB-3/4	127001	Balance Valve	3/4" NPTF	2" x 9-1/4"	125 PSIG	250°F	6	26
TB-1	127002	Balance Valve	1" NPTF	2" x 9-1/4"	125 PSIG	250°F	6	26

# ACCESSORIES PSH - Primary/Secondary Header

## Description

The B&G low-loss header, Model PSH, is a combination air separator and manifold that creates independent primary and secondary circuits. The B&G Model PSH is equipped with a purge valve allowing the user to remove any debris deposited on the bottom of the vessel and an air vent releasing trapped air in the system. The insulation, which is provided as standard, prevents water vapors entering from the outside and eliminates the formation of condensate on the PSH body.

## Operating Data

### With Insulation:

Working Pressure: 150 PSI  
 Operating Temperature Threaded: 32°- 210°F  
 Operating Temperature Flanged: 32°- 220°F

### Without Insulation:

Working Pressure: 150 PSI  
 Operating Temperature Threaded & Flanged: 32°-230°F

## Materials of Construction

Body: Steel  
 Air Vent: Brass  
 Drain Valve: Brass  
 Insulation-Threaded: PEX  
 Insulation-Flanged: Polyurethane Foam

## Connection

1", 1-1/4" and 1-1/2" Female NPT  
 2", 2-1/2", 3" and 4" ANSI 150 CLASS Flange

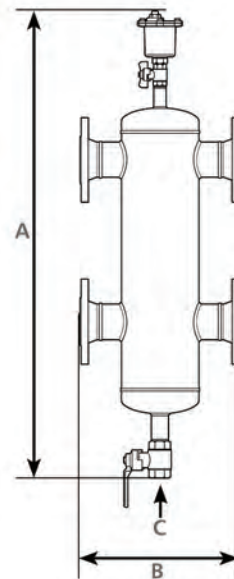
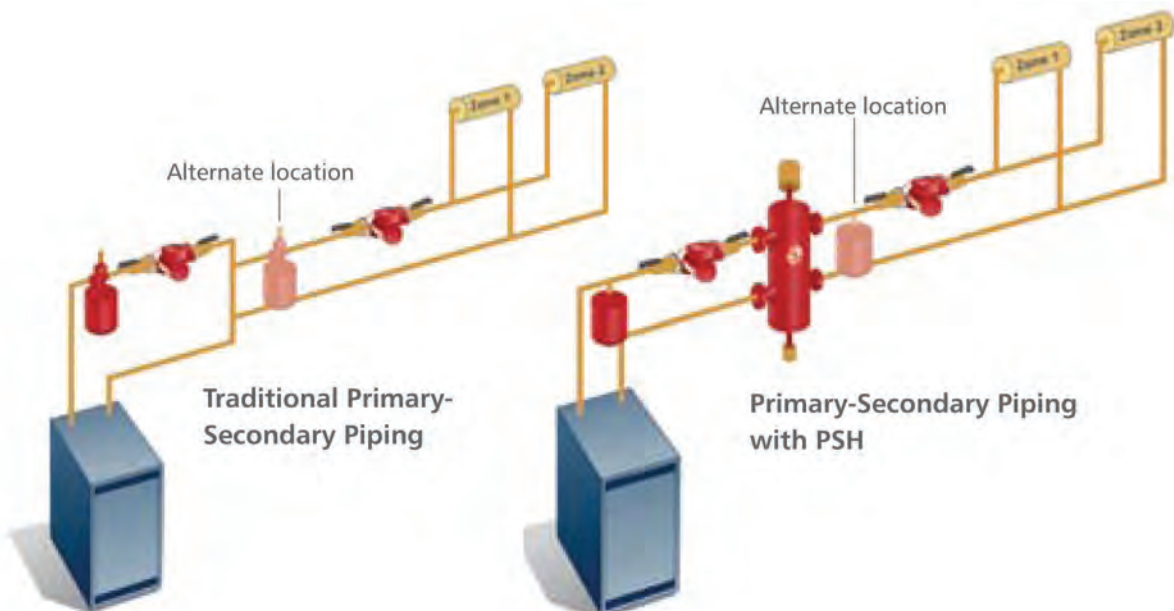

## Specifications

Model Number	Part Number	Connection Size Inches (mm)	Max Flow GPM (m3/h)	A Inches (mm)	B Inches (mm)	C - Drain Connection Size Inches (mm) NPT	Weight LBS (Kg)
PSH-1	112465	1 (25.4)	11 (2.5)	24-3/8 (619)	8-7/8 (225)	1/2 (12.7)	6.0 (2.7)
PSH-1.25	112466	1-1/4 (31.75)	18 (4)	26-3/4 (679)	9-3/4 (248)	1/2 (12.7)	8.3 (3.8)
PSH-1.5	112467	1-1/2 (38.1)	26 (6)	28-1/3 (719)	11-1/8 (282)	1/2 (12.7)	12.6 (5.7)
PSH-2	112468	2 (50.8)	40 (9)	42 (1069)	13-13/16 (350)	1-1/4(31.7)	78.7 (35.7)
PSH-2.5	112469	2-1/2 (63.5)	80 (18)	42 (1069)	13-13/16 (350)	1-1/4(31.7)	87.7 (39.8)
PSH-3	112470	3 (76.2)	124 (28)	50-3/8 (1279)	18-3/8 (466)	1-1/4(31.7)	108.0 (49)
PSH-4	112471	4 (101.6)	247 (56)	50-3/8 (1279)	18-1/2 (470)	1-1/4(31.7)	116.8 (53)

# TANKS HFT Diaphragm Tanks • Expansion Tanks for Hydronic Heating

## Description

Bell & Gossett HFT expansion tanks are designed to absorb the force of thermal expansion in hydronic heating systems. Series HFT tanks for hydronic heating systems are available in sizes from 2–86 gallons. The Series HFT tank is designed to absorb the force of thermal expansion of heating water to maintain proper pressurization in a closed hydronic system. The heavy duty butyl diaphragm separates system water from the air in the tank preventing water logging problems.

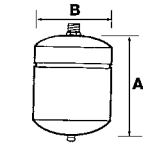

HFT-15 thru HFT-90

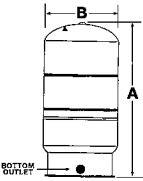

HFT-30V thru HFT-160V

## Specifications

Model Number	Part Number	Volume Gallons (Liters)		Height (A) Inches (mm)	Diameter (B) Inches (mm)	System Connection	Approx. Shpg. Wt. lbs. (Kg)
		Tank	Acceptance				
HFT-15	1BN326	2 (7.5)	1.0 (3.7)	12-5/8 (321)	8 (203)	1/2" NPTM	5 (2.3)
HFT-30	1BN327	4.4 (16.6)	2.5 (9.4)	14 (355)	11 (279)		9 (4.1)
HFT-60	1BN328	7.6 (28.7)	2.5 (9.4)	17-1/4 (438)	11 (279)		14 (6.4)
HFT-90	1BN329	14 (53)	11.3 (42.8)	21 (533)	15-3/8 (390)	1" NPTF	23 (10.4)
HFT-30V	1BN330	14 (53)	11.3 (42.8)	24-3/4 (629)	15-3/8 (390)		24 (11)
HFT-40V	1BN331	20 (75.7)	11.3 (42.8)	32-1/2 (826)	15-5/8 (390)		34 (15.5)
HFT-60V	1BN332	32 (121.1)	11.3 (42.8)	47-1/2 (1207)	15-5/8 (390)	1-1/4" NPTF	52 (23.6)
HFT-90V	1BN333	44 (166.5)	34 (128.7)	36-1/2 (927)	22 (559)		64 (29)
HFT-110V	1BN334	62 (234.6)	34 (128.7)	48-1/2 (1232)	22 (559)		89 (40.5)
HFT-160V	1BN335	86 (325.5)	46 (174.1)	46 (1168)	22 (559)	116 (53)	

## Operating Data

Maximum Working Pressure: 100 PSI (689 kPa)  
 Maximum Operating Temperature: 240°F (115°C)  
 Standard Factory Pre-charge: 12 PSI (83 kPa)

## Materials of Construction

Shell: Carbon Steel  
 Diaphragm: Heavy Duty Butyl Rubber  
 Connection: Steel



## Sizing Guideline

Boiler Size	Type of Radiation			
	Finned Tube Baseboard or Radiant Panel	Convectors or Unit Heaters	Radiators Cast Iron	Baseboard Cast Iron
Net Output				
BTU/HR	Use Tank Model			
25,000	HFT-15	HFT-15	HFT-15	HFT-15
50,000	HFT-15	HFT-15	HFT-30	HFT-30
75,000	HFT-30	HFT-30	HFT-30	HFT-60
100,000	HFT-30	HFT-60	HFT-60	HFT-60
125,000	HFT-30	HFT-60	HFT-60	HFT-90
150,000	HFT-30	HFT-60	HFT-90	HFT-90
200,000	HFT-60	HFT-60	HFT-30V	HFT-30V
250,000	HFT-60	HFT-90	HFT-30V	HFT-40V
300,000	HFT-90	HFT-30V	HFT-30V	HFT-40V
350,000	HFT-30V	HFT-30V	HFT-40V	HFT-60V
400,000	HFT-30V	HFT-40V	HFT-40V	HFT-60V

Assumptions: fill pressure 12 PSI, relief pressure 30 PSI, avg. system temp. 200°F, system fluid is water, consult factory with requirements not shown

## Compression Tanks

Air-tight, ASME constructed. Available in painted steel. Sizes 15 to 505 gallons. Gauge glass tapplings are standard. Always use with B&G Airtrol Tank Fittings.



## Airtrol® Tank Fittings

Directs free air to the compression tank. Restricts thermal circulation to boiler. Establishes initial tank air level. Allows compression tank size reduction.

ATFL



ATF



## Specifications

Model Number	Part Number	Capacity Gallons	Required Airtrol Fitting	Tank Dia. Inches	Tank Length Inches	Approx. Shpg. Wt. (Lbs)
15	116029	15	ATF-12	12	33	50
24	116030	24			51	72
30	116031	30			48	80
40	116032	40			63	104
60	116033	60	ATF-16	16	72	134
80	116034	80	ATF-20	20	62	160
100	116035	100	ATF-20		78	186
120	116036	120	ATF-24		65	217
135	116037	135			72	230
175	116038	175	ATFL	30	62-1/4	320
220	116039	220			77	370
240	116040	240			84	420
305	116041	305			105-3/4	482
400	116042	400			93	656
505	116840	505			116	745

## Specifications

Model Number	Part Number	Tank Dia. Inches	Connection (NPT)		Approx. Shpg. Wt. (Lbs)
			Tank	Boiler	
ATF-9	112008	9	1/2" M	3/4" M	2-1/4
ATF-12	112010	12 - 14			2-1/2
ATF-16	112011	16 - 18			2-3/4
ATF-20	112026	20 - 22			
ATF-24	112013	24	1" F	1" F	14
ATFL*	112014	>100 gal			

\* DT-2 Drain-O-Tank Air Charger comes with ATFL model

Dimensions are approximate and subject to change. Consult factory for certified dimensions. Part numbers in table above are for paint steel tanks.

# TANKS PT Diaphragm Tanks

## Expansion Tanks for Potable Water Systems

### Description

Bell & Gossett PT expansion tanks are designed to absorb the force of thermal expansion in domestic potable water systems. Tanks for potable water systems, Series PT and PTA (ASME construction) are available in sizes from 2–528 gallons.



### Specifications

Model Number	Part Number	Volume Gallons (Liters)		Height (A) Inches (mm)	Diameter (B) Inches (mm)	System Connection	Approx. Shpg. Wt. lbs. (Kg)
		Tank	Acceptance				
PT-5	1BN317LF	2 (8)	1.0 (4)	12-5/8 (321)	8 (203)	3/4" NPTM	5 (2.3)
PT-12	1BN318LF	4.4 (17)	3.2 (12)	15 (381)	11 (279)	3/4" NPTF	9 (4.1)
PT-25V	1BN319LF	10.3 (39)	10.3 (39)	19-1/4 (489)	15-3/8 (391)	1" NPTF	23 (10.4)
PT-30V	1BN320LF	14 (53)	11.3 (43)	23-7/8 (605)	15-3/8 (391)		25 (11.3)
PT-42V	1BN321LF	20 (76)	11.3 (43)	31-5/8 (802)	15-3/8 (391)		33 (15)
PT-60V	1BN322LF	34 (129)	34 (129)	29-5/8 (752)	22 (559)	1-1/4" NPTF	69 (31.2)
PT-80V	1BN323LF	44 (167)	34 (129)	36 (914)	22 (559)		69 (31.2)
PT-180V	1BN324LF	62 (235)	34 (129)	46-3/4 (1187)	22 (559)		92 (41.7)
PT-210V	1BN325LF	86 (326)	46.4 (176)	47-1/4 (1200)	26 (660)		123 (55.8)

Larger sizes and ASME constructed models are available.

Code approvals: PT-5, PT-12



PT-25V thru PT-210



### Residential/Light Commercial Non-ASME Diaphragm Tanks

#### Operating Data

Maximum Working Pressure:  
PT-5 & PT-12: 150 PSI (1035 kPa)  
PT-25V thru PT-210V: 100 PSI (689 kPa)  
Maximum Operating Temperature: 200°F (93°C)

#### Materials of Construction

Shell: Carbon Steel  
Liner: Polypropylene  
Diaphragm: Heavy Duty Butyl Rubber  
System Connection: PT-25V thru PT-210V are stainless steel. All others are brass  
Factory Pre-charge: 40 PSI (276 kPa)

### Commercial Non-ASME Bladder Tanks

Maximum Working Pressure: 150 PSI (1035 kPa)  
Maximum Operating Temperature: 240°F (116°C)

#### Materials of Construction

Shell: Carbon Steel  
Liner: Polypropylene  
Diaphragm: Heavy Duty Butyl Rubber  
System Connection: Bronze  
Factory Pre-charge: 55 PSI (379 kPa)

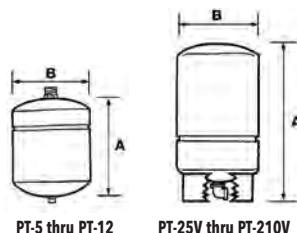

## WTX Diaphragm Tanks

### Description

The Series WTX tanks will help protect the pump and pressure switches against short cycling. The potable well tank delivers adequate water under pressure between pump cycles to meet the required demand. It will provide economical system operation by minimizing pump starts, extending pump motor life, and saving energy. The WTX tank will also assist the pump in meeting peak demands.

### Specifications

Model Number	Part Number	Volume Gallons (Liters)		System Drawdown in Gallons			Height (A) Inches (mm)	Diameter (B) Inches (mm)	System Connection	Approx. Shpg. Wt. lbs. (Kg)
		Tank	Acceptance Factor	20/40	30/50	40/60				
WTX-2	1BN300	2 (8)	0.45	0.8	0.7	0.6	12-5/8 (321)	8 (203)	3/4" NPTM	5 (2.3)
WTX-5	1BN301	4.4 (17)	0.55	1.8	1.5	1.3	15 (381)	11 (279)		9 (4.1)
WTX-8	1BN302	7.6 (33)	0.42	3.1	2.6	2.2	22-1/4 (629)	11 (279)		15 (7)
WTX-10	1BN303	10.3 (39)	1.00	4.1	3.5	3.0	17-3/4 (451)	15-3/8 (390)	1" NPTM	20 (9)
WTX-14	1BN304	14 (53)	0.81	5.6	4.8	4.1	22 (559)	15-3/8 (390)	1" NPTF	22 (10)
WTX-10S	1BN305	10.3 (39)	1.00	4.1	3.5	3.0	19-1/4 (489)	15-3/8 (390)		23 (10)
WTX-14S	1BN306	14 (53)	0.81	5.6	4.8	4.1	23-7/8 (605)	15-5/8 (390)		25 (11)
WTX-20S	1BN307	20 (76)	0.57	8.0	6.8	5.9	31-5/8 (802)	15-3/8 (390)		33 (15)
WTX-26S	1BN308	26 (98)	0.44	10.5	8.8	7.6	38-1/4 (972)	15-3/8 (390)	36 (16)	
WTX-32S	1BN309	32 (121)	0.35	—	10.9	9.4	46-1/2 (1181)	15-5/8 (390)	43 (20)	
WTX-34S	1BN310	34 (129)	1.00	13.7	11.6	10.0	29-5/8 (752)	22 (559)	61 (28)	
WTX-44S	1BN311	44 (167)	0.77	17.7	15	12.9	36 (914)	22 (559)	69 (31)	
WTX-62S	1BN312	62 (235)	0.55	24.9	21.1	18.2	46-3/4 (1187)	22 (559)	92 (41)	
WTX-81S	1BN313	81 (307)	0.41	32.6	27.5	23.8	56-3/8 (1432)	22 (559)	103 (47)	
WTX-86S	1BN315	86 (326)	0.54	34.6	29.2	25.3	47-1/4 (1200)	26 (660)	123 (56)	
WTX-119S	1BN316	119 (450)	0.39	47.8	40.5	35.0	61-7/8 (1572)	26 (660)	166 (75)	

System Connection: WTX-2 thru WTX-14 = Copper Lined Steel Fitting; All others = Steel with Stainless Steel Elbow  
Factory Pre-Charge: WTX-2, WTX-5 = 18PSI (124kPa); WTX-8 = 28 PSI (193 kPa); All other WTX tanks = 38 PSI (262 kPa)

### Operating Data

Maximum Operating Temperature:  
200°F (93°C)  
Maximum Working Pressure:  
100 PSI (689 kPa)

### Materials of Construction

Shell: Carbon Steel  
Liner: Polypropylene  
Diaphragm: Heavy Duty Butyl Rubber  
System Connection: WTX-2 thru WTX-14 = Copper Lined Steel Fitting; all others are Steel with Stainless Steel Elbow  
Factory Pre-charge:  
WTX-2, WTX.5 = 18 PSI (124 kPa);  
WXT-8 = 28 PSI (193 kPa);  
All other WTX tanks = 38 PSI (262 kPa)

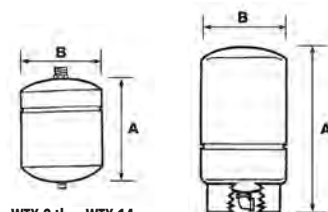

# VALVES TPV - Tank Purge Valves

## Description

Combination full port shut-off valve and drain valve used to connect an expansion tank to the system. It is important that the pre-charge in an expansion tank be maintained at the proper pressure at all times. This pressure is the lowest system operating pressure. When the tank's pressure is adjusted, there should be no system liquid in it. This pre-charge should be checked and adjusted when:

- Tank is first installed
- If system is started or operating with the incorrect tank pre-charge
- Annually to assure proper pre-charge pressure at all times

The TPV (Tank Purge Valve) is ideal for this as the tank can be isolated from the system, drained and the pre-charge checked and adjusted without draining or shutting down the system.

The TPV also serves as a service valve should the tank need to be removed or have the bladder changed. These valves are furnished standard with a drain valve with a standard 5/8" hose connection.

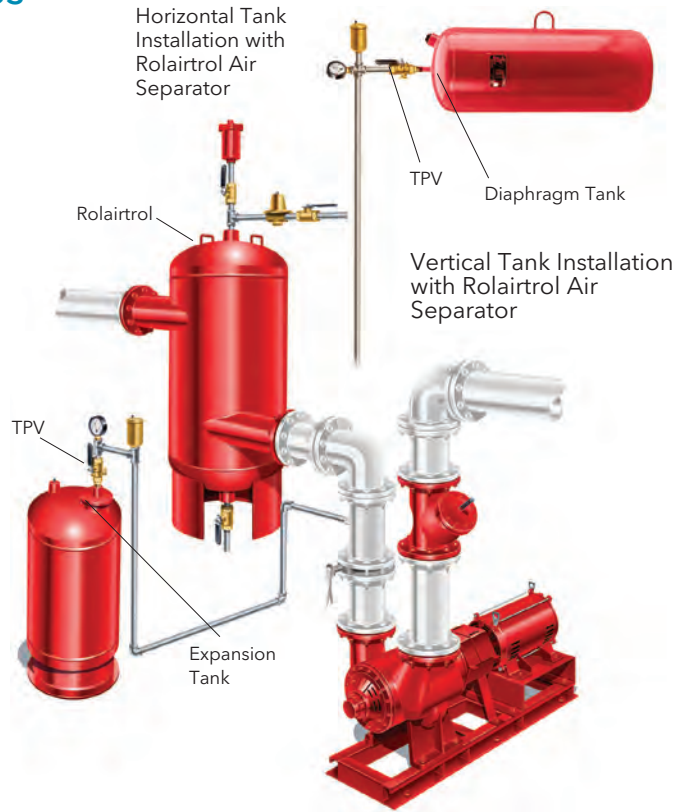

## Operating Data

Maximum Working Pressure:  
400 PSIG (2,758 kPa)

Maximum Operating Temperature:  
-4°F (-20°C) to 250°F (121°C)

## Materials of Construction

Valve Body: Brass  
Ball: Chrome Plated  
Ball Seal: PTFE  
Stem: Explosion Proof  
O-Ring: EPDM

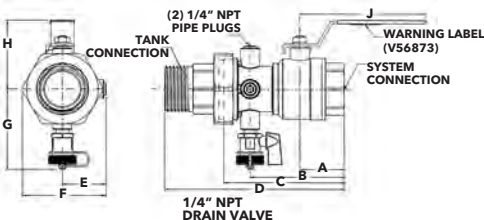

These valves are not recommended to be used on potable water tanks.

## Specifications

Model Number	Part Number	System Connection	Tank Connection	Dimensions* Inch (mm)									Approx. Weight Lbs.
				A	B	C	D	E	F	G	H	J	
TPV-1/2SF	113226	1/2" Female SWT	1/2" Female NPT	1.67 (42.4)	2.25 (57.2)	3.15 (80.0)	3.82 (97.0)	0.84 (21.3)	1.60 (40.6)	2.36 (59.9)	1.75 (44.5)	3.34 (84.8)	1.0 (0.5)
TPV-1/2FF	113227	1/2" Female NPT	1/2" Female NPT	1.19 (30.2)	2.00 (50.8)	2.90 (73.7)	3.55 (90.4)	0.84 (21.3)	1.60 (40.6)	2.36 (59.9)	1.75 (44.5)	3.34 (84.8)	1.0 (0.5)
TPV-1/2SM	113228	1/2" Female SWT	1/2" Male NPT	1.29 (32.2)	2.25 (57.2)	3.15 (80.0)	4.73 (120.1)	0.84 (21.3)	1.60 (40.6)	2.36 (59.9)	1.75 (44.5)	3.34 (84.8)	1.0 (0.5)
TPV-1/2FM	113229	1/2" Female NPT	1/2" Male NPT	1.06 (26.9)	2.00 (50.6)	2.90 (73.7)	4.47 (113.6)	0.84 (21.3)	1.60 (40.6)	2.36 (59.9)	1.75 (44.5)	3.34 (84.8)	1.0 (0.5)
TPV-3/4SF	113230	3/4" Female SWT	3/4" Female NPT	1.67 (42.2)	2.85 (72.4)	3.72 (94.5)	4.53 (115.2)	1.06 (26.9)	1.95 (49.5)	2.66 (67.6)	1.89 (48.0)	3.50 (88.9)	1.24 (0.6)
TPV-3/4FF	113231	3/4" Female NPT	3/4" Female NPT	1.19 (30.2)	2.50 (63.5)	3.26 (82.8)	4.06 (103.1)	1.06 (26.9)	1.95 (49.5)	2.66 (67.6)	1.69 (48.0)	3.50 (88.9)	1.24 (0.6)
TPV-3/4SM	113232	3/4" Female SWT	3/4" Male NPT	1.67 (42.2)	2.85 (72.4)	3.72 (94.5)	5.50 (140.0)	1.06 (26.9)	1.95 (49.5)	2.66 (67.6)	1.69 (48.0)	3.50 (88.9)	1.25 (0.6)
TPV-3/4FM	113233	3/4" Female NPT	3/4" Male NPT	1.19 (30.2)	2.50 (63.5)	3.26 (82.8)	5.03 (127.6)	1.06 (26.9)	1.95 (49.5)	2.66 (67.6)	1.69 (48.0)	3.50 (88.9)	1.25 (0.6)
TPV-1SF	113234	1" Female SWT	1" Female NPT	1.95 (49.5)	3.18 (80.6)	4.14 (105.2)	5.05 (126.3)	1.23 (31.2)	2.06 (52.3)	2.71 (68.6)	2.00 (50.8)	4.00 (101.6)	1.71 (0.8)
TPV-1FF	113235	1" Female NPT	1" Female NPT	1.46 (36.8)	2.63 (66.5)	3.60 (91.4)	4.50 (114.3)	1.23 (31.2)	2.06 (52.3)	2.71 (68.6)	2.00 (50.8)	4.00 (101.6)	1.71 (0.8)
TPV-1SM	113236	1" Female SWT	1" Male NPT	1.95 (49.5)	3.18 (80.6)	4.14 (105.2)	6.16 (156.5)	1.23 (31.2)	2.06 (52.3)	2.71 (68.6)	2.00 (50.8)	4.00 (101.6)	1.75 (0.8)
TPV-1FM	113237	1" Female NPT	1" Male NPT	1.45 (36.8)	2.53 (60.8)	3.60 (91.4)	5.60 (142.2)	1.23 (31.2)	2.06 (52.3)	2.71 (68.6)	2.00 (50.8)	4.00 (101.6)	1.75 (0.8)
TPV-1 1/4SF	113238	1 1/4" Female SWT	1 1/4" Female NPT	2.13 (54.1)	3.94 (100.1)	5.14 (130.6)	6.10 (154.9)	1.34 (34.0)	2.71 (68.8)	2.96 (75.2)	2.45 (62.2)	4.50 (114.3)	3.15 (1.5)
TPV-1 1/4FF	113239	1 1/4" Female NPT	1 1/4" Female NPT	1.55 (39.4)	3.37 (85.6)	4.56 (115.6)	5.50 (139.7)	1.34 (34.0)	2.71 (68.8)	2.96 (75.2)	2.45 (62.2)	4.50 (114.3)	3.15 (1.5)
TPV-1 1/4SM	113240	1 1/4" Female SWT	1 1/4" Male NPT	2.13 (54.1)	3.94 (100.1)	5.14 (130.6)	7.11 (180.6)	1.34 (34.0)	2.71 (68.8)	2.96 (75.2)	2.45 (62.2)	4.50 (114.3)	3.19 (1.5)
TPV-1 1/4FM	113241	1 1/4" Female NPT	1 1/4" Male NPT	1.55 (39.4)	3.37 (85.6)	4.56 (115.6)	6.52 (165.6)	1.34 (34.0)	2.71 (68.8)	2.96 (75.2)	2.45 (62.2)	4.50 (114.3)	3.19 (1.5)
TPV-1 1/2SM	113242	1 1/2" Female SWT	1 1/2" Male NPT	2.54 (64.5)	4.66 (118.4)	5.90 (149.9)	8.32 (211.3)	1.85 (47.0)	3.25 (82.6)	3.38 (85.9)	3.00 (76.2)	5.30 (134.5)	5.50 (2.5)
TPV-1 1/2FM	113243	1 1/2" Female NPT	1 1/2" Male NPT	1.91 (48.5)	3.97 (100.8)	5.12 (130.1)	7.64 (194.1)	1.85 (47.0)	3.25 (82.6)	3.38 (85.9)	3.00 (76.2)	5.30 (134.5)	5.50 (2.5)
TPV-2SM	113244	2" Female SWT	2" Male NPT	2.89 (72.4)	4.57 (116.1)	6.80 (172.7)	9.80 (248.9)	2.00 (50.8)	4.00 (101.6)	3.52 (89.4)	3.33 (84.6)	6.12 (155.5)	8.00 (3.63)
TPV-2FM	113245	2" Female NPT	2" Male NPT	2.06 (52.3)	4.65 (118.1)	5.85 (148.6)	8.87 (225.3)	2.00 (50.8)	4.00 (101.6)	3.52 (89.4)	3.33 (84.6)	6.12 (155.5)	8.00 (3.63)

\*All dimensions +/- 0.125 (3.2 mm) tolerance. Dimensions are subject to change. Not to be used for construction purposes unless certified.

# HEAT EXCHANGERS Brazed Plate Heat Exchangers

## Description

Model BPX brazed plate heat exchangers offer the highest level of thermal efficiency and durability in a compact, low cost unit. The corrugated plate design provides very high heat transfer coefficients, resulting in a more compact design. The unit's stainless steel plates are vacuum brazed together to form a durable, integral piece that can withstand high pressure and temperature.

The BPX heat exchangers offer a compact design compared to shell and tube exchangers

- 1/6 the size of shell and tube
- 1/5 the weight of shell and tube
- 1/8 the liquid required of shell and tube
- 1/3 to 1/5 of the surface area required

BPX units are ideal for a wide variety of hydronic applications such as:

- Radiant Floor Heating
- Domestic Water Heating
- Snow MELT Systems
- Swimming Pool Heating

## Operating Data

Design Pressure: 435 PSI (30 bar)  
Design Temperature: 450°F (232°C)  
Plates: Stainless Steel  
Brazing Material: Copper  
Connections: From 1/2 inch to 4 inch  
Capacity: Up to 800 GPM  
Construction Codes : UL, CRN, ASME Code Stamp Option

**Also available in double-wall design.**

Designed for dependability – Small size. Big impact.



**Mechanical Design:**  
Design pressures up to 435 PSIG.  
Maximum design temperature up to 450°F. Minimum design temperature to -310°F.

**Construction Codes:**  
Available codes include UL, CRN, and ASME code stamp.

**Materials:**  
Stainless steel 316L plates.  
Copper brazed material.



**Connections:**  
From 1/2-inch to 4-inch. Standard connection options include NPT, SAE flanged and sweat. Custom connections available.

**Capacity:**  
Up to 800 GPM and 350 sq.ft. of surface area.

**Mounting:**  
Reduce mounting costs with optional threaded studs or integral mounting bracket.





# HEAT EXCHANGERS Brazed Plate Heat Exchangers

## Quick Selection Tables

Domestic Water Heating							
Boiler Side: Water 180° F supply, 130° F return Domestic Water Side: Water 50° F supply, 140° F return							
Model	Heat Exchanged BTU/Hr	Boiler Side		Domestic Water Side		B&G Pump Selection <sup>†</sup>	Pipe Size <sup>††</sup>
		Flow GPM	Pressure Drop PSI	Flow GPM	Pressure Drop PSI		
BP400-10 (¾" MPT)	60,000	2.5	1.6	1.3	0.3	NBF-9U	¾"
BP400-20 (¾" MPT)	150,000	6.2	2.1	3.3	0.6	NBF-9U	¾"
BP400-30 (¾" MPT)	225,000	9.3	2.2	5.0	0.7	NBF-9U	1"
BP400-40 (¾" MPT)	350,000	14.4	3.4	7.8	1.0	NBF-12	1¼"
BP410-30 (1" MPT)	450,000	18.6	6.2	10.0	1.8	NBF-25	1½"
BP410-40 (1" MPT)	600,000	24.8	6.2	13.3	2.0	NBF-25	1½"
BP410-50 (1" MPT)	800,000	33.0	6.9	17.8	2.4	NBF-25	1½"
BP410-60 (1" MPT)	900,000	37.1	6.9	20.0	2.2	NBF-25	2"
BP410-80 (1" MPT)	1,100,000	45.4	6.8	24.4	2.2	NBF-36	2"
BP423-30 (2" MPT)	1,500,000	61.9	4.6	33.3	1.4	NBF-45	2"
BP423-40 (2" MPT)	2,000,000	82.5	4.6	44.4	1.4	PL-45B	2½"
BP423-50 (2" MPT)	2,500,000	103.1	4.8	55.5	1.5	PL-75B	2½"

Larger models are available upon request. † Assumptions: 200 ft. TEL of copper pipe with (6) 90 degree elbows. †† Pipe size shown is not the connection size of the heat exchanger.

Domestic Water Heating - Double Wall							
Boiler Side: Water 180° F supply, 130° F return Domestic Water Side: Water 50° F supply, 140° F return							
Model	Heat Exchanged BTU/Hr	Boiler Side		Domestic Water Side		B&G Pump Selection <sup>†</sup>	Pipe Size <sup>††</sup>
		Flow GPM	Pressure Drop PSI	Flow GPM	Pressure Drop PSI		
BPDW410-20 (1" MPT)	60,000	2.5	0.2	1.3	0.1	NBF-9U	5/8"
BPDW410-34 (1" MPT)	150,000	6.2	0.4	3.3	0.1	NBF-9U	3/4"
BPDW415-24 (1" MPT)	225,000	9.3	3.8	5.0	0.9	NBF-9U	1"
BPDW415-34 (1" MPT)	350,000	14.4	4.5	7.8	1.1	NBF-12	1-1/4"
BPDW415-40 (1" MPT)	450,000	18.6	5.4	10.0	1.4	NBF-25	1-1/4"
BPDW415-60 (1" MPT)	600,000	24.8	4.6	13.3	1.2	NBF-25	1-1/2"
BPDW415-80 (1" MPT)	800,000	33.0	5.1	17.8	1.4	NBF-25	1-1/2"
BPDW415-100 (1" MPT)	900,000	37.1	4.8	20.0	1.8	NBF-25	2"
BPDW415-110 (1" MPT)	1,100,000	45.4	6.3	24.4	3.1	NBF-36	2"
(2) BPDW415-80 (1" MPT)	1,500,000 <sup>†††</sup>	61.9	4.5	33.3	1.3	NBF-45	2"
(2) BPDW415-100 (1" MPT)	2,000,000 <sup>†††</sup>	82.5	5.9	44.4	1.7	NBF-45B	2-1/2"

† Assumptions: 20 ft. of copper pipe with (6) 90 degree elbows.  
†† Pipe size shown isn't the connection size of the heat exchanger.  
††† Two units are required in parallel.

Snow Melt Applications							
Boiler Side: Water 180° F supply, 160° F return Snow Side: Water 40% P.G. 100° F supply, 130° F return							
Model	Heat Exchanged BTU/Hr	Boiler Side		Snow Melt Side		B&G Pump Selection <sup>†</sup>	Pipe Size <sup>††</sup>
		Flow	Pressure Drop	Flow	Pressure Drop		
		GPM	PSI	GPM	PSI		
BP400-10 (¾" MPT)	30,000	3.1	2.4	2.1	0.9	NRF-25	¾"
BP400-10 (¾" MPT)	45,000	4.6	5.1	3.2	2.1	NRF-35	¾"
BP400-14 (¾" MPT)	60,000	6.2	4.2	4.3	1.9	NRF-25	1"
BP400-20 (¾" MPT)	100,000	10.3	5.4	7.1	2.7	NRF-36	1"
BP400-40 (¾" MPT)	175,000	18.0	5.2	12.5	2.8	NRF-36	1½"
BP412-30 (1" MPT)	250,000	25.8	4.1	17.9	2.1	PL-36	1½"
BP412-30 (1" MPT)	300,000	30.9	5.8	21.4	2.9	PL-55	2"
BP412-50 (1" MPT)	450,000	46.4	6.2	32.1	3.3	613	2"
BP424-20 (2" MPT)	600,000	61.8	4.8	42.9	2.8	609	2"
BP424-30 (2" MPT)	900,000	92.7	4.8	64.3	3.0	614	2½"
BP424-40 (2" MPT)	1,200,000	123.6	5.1	85.7	3.2	625	3"
BP424-50 (2" MPT)	1,350,000	139.1	4.7	96.4	2.9	625	3"

Larger models are available upon request.  
† Assumptions: Longest radiant loop is 250 ft. PEX.  
†† Pipe size shown isn't the connection size of the heat exchanger.

Outdoor Wood Boiler					
Boiler Side: Water 180° F supply, 155° F return House Side: Water 140° F supply, 165° F return					
Model	Heat Exchanged BTU/Hr	Boiler Side		House Side	
		Flow	Pressure Drop	Flow	Pressure Drop
		GPM	PSI	GPM	PSI
BP400-20LP (¾" MPT)	30,500	2.52	0.4	2.5	0.3
BP400-30LP (¾" MPT)	50,000	4.12	0.5	4.1	0.4
BP400-40LP (¾" MPT)	70,000	5.77	0.6	5.7	0.6
BP410-20LP (1" MPT)	80,000	6.60	1.9	6.5	1.6
BP410-30LP (1" MPT)	130,000	10.72	2.2	10.6	1.92
BP410-40LP (1" MPT)	179,500	14.80	2.3	14.6	2.2
BP410-50LP (1" MPT)	229,500	18.92	2.5	18.7	2.4
BP410-60LP (1" MPT)	279,000	23.00	2.8	22.8	2.6
BP410-70LP (1" MPT)	329,000	27.13	3.0	26.8	2.9
BP410-80LP (1" MPT)	378,500	31.21	3.3	30.9	3.2
BP410-90LP (1" MPT)	428,500	35.33	3.7	34.9	3.6
BP410-100LP (1" MPT)	478,000	39.41	4.0	39.0	4.0

Larger models are available upon request.

Swimming Pool Heating						
Boiler Side: Water 180° F supply, 130° F return Pool Side: Water 70° F supply, 107° F return						
Model <sup>‡</sup>	Pool Size Gallons <sup>‡</sup>	Heat Exchanged BTU/Hr	Boiler Side		Pool Side	
			Flow	Pressure Drop	Flow <sup>2</sup>	Pressure Drop
			GPM	PSI	GPM	PSI
BP400-10 (¾" MPT)	2,000	33,300	1.37	0.5	1.8	0.6
BP400-10 (¾" MPT)	6,000	99,900	4.10	4.1	5.4	5.0
BP400-20 (¾" MPT)	8,000	133,200	5.50	1.7	7.3	2.5
BP400-30 (¾" MPT)	15,000	250,234	10.00	2.7	14.0	4.5
BP412-20 (1" MPT)	20,000	333,645	13.00	2.5	18.0	3.4
BP412-20 (1" MPT)	30,000	500,467	20.70	5.6	27.2	7.7
BP412-30 (1" MPT)	40,000	667,290	27.00	3.9	36.0	6.9
BP424-20 (2" MPT)	60,000	1,000,936	40.00	2.3	54.0	3.6
BP424-30 (2" MPT)	80,000	1,334,581	53.00	1.9	72.0	3.1
BP424-40 (2" MPT)	100,000	1,668,226	67.00	2.8	90.0	4.7
BP424-50 (2" MPT)	120,000	2,001,871	82.50	2.5	108.0	4.2
BP424-50 (2" MPT)	150,000	2,502,000	103.20	2.7	135.6	4.7

Larger models are available upon request.  
1) Provides approx. 2° F per hour heating with 180° F boiler to achieve 80° F pool temperature.  
2) Pool water flow rate usually requires flow by pass from main pool circulation.  
3) Chlorinated pool water can be corrosive to SS316L and Copper. Proper control of chlorine levels is required or alternate materials of construction should be considered.

Radiant Floor Heating							
Boiler Side: Water 180° F supply, 160° F return Radiant Floor Side: Water 100° F supply, 120° F return							
Model	Heat Exchanged BTU/Hr	Boiler Side		Radiant Floor Side		B&G Pump Selection <sup>†</sup>	Pipe Size <sup>††</sup>
		Flow	Pressure Drop	Flow	Pressure Drop		
		GPM	PSI	GPM	PSI		
BP400-10 (¾" MPT)	30,000	3.1	2.4	3.0	1.6	NRF-25	¾"
BP400-10 (¾" MPT)	50,000	5.2	6.1	5.0	4.2	NRF-36	1"
BP400-20 (¾" MPT)	100,000	10.3	5.2	10.1	4.4	NRF-36	1½"
BP400-30 (¾" MPT)	150,000	15.5	5.3	15.2	4.9	NRF-36	1½"
BP400-40 (¾" MPT)	200,000	20.6	5.8	20.2	5.5	NRF-36	1½"
BP411-20 (1" MPT)	250,000	25.8	3.3	25.2	3.0	PL-36	2"
BP411-20 (1" MPT)	350,000	36.1	6.3	35.3	5.6	PL-55	2"
BP411-30 (1" MPT)	450,000	46.4	6.1	45.4	5.8	607	2"
BP424-20 (2" MPT)	600,000	61.8	4.8	60.6	4.2	609	2½"
BP424-30 (2" MPT)	900,000	92.7	4.8	90.9	4.5	611	3"
BP424-40 (2" MPT)	1,200,000	123.6	5.1	121.2	5.0	625	3"
BP424-50 (2" MPT)	1,350,000	139.1	4.7	136.3	4.6	619	3"

Larger models are available upon request.  
† Assumptions: Longest radiant loop is 200 ft. PEX.  
†† Pipe size shown isn't the connection size of the heat exchanger.

# WASTEWATER Submersible Sump Pumps

## Description

Sump pumps are specifically designed for basement draining, dewatering and water transfer. It has a range of capacities up to 70 GPM and maximum heads of 37 TDH ranging from 1/4 HP to 3/4 HP. The stainless steel or cast iron construction is available with 1-1/2" discharge connections. Battery back-up sump pumps also available for emergency back up service in the event of a power outage.

## SC

### Specifications

- Maximum solids 1/2"

Part Number
SC0311AV
SC0511AV
SC0711AV

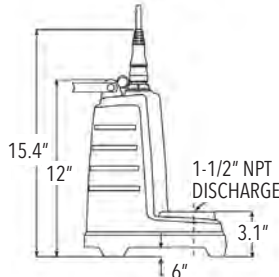
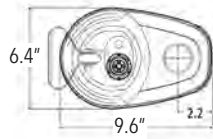

SC05 and SC07

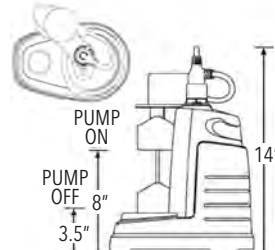

SC03

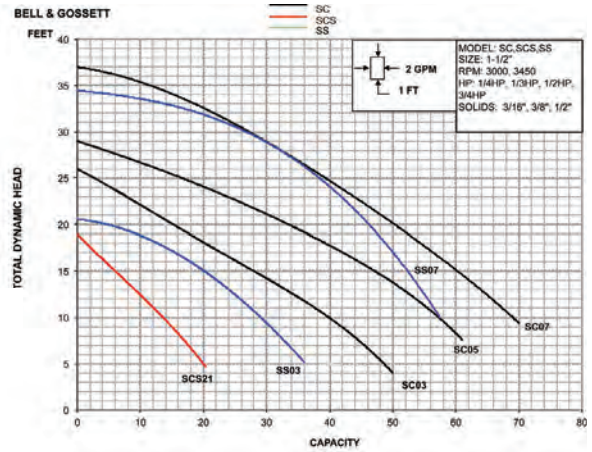

## SS

### Specifications

- Maximum solids: 3/8" spherical

Part Number	F	H
SS0311AT	9-3/4	7-5/8
SS0711ATF	11-1/4	9-1/8
SS0311AV	9-3/4	7-5/8

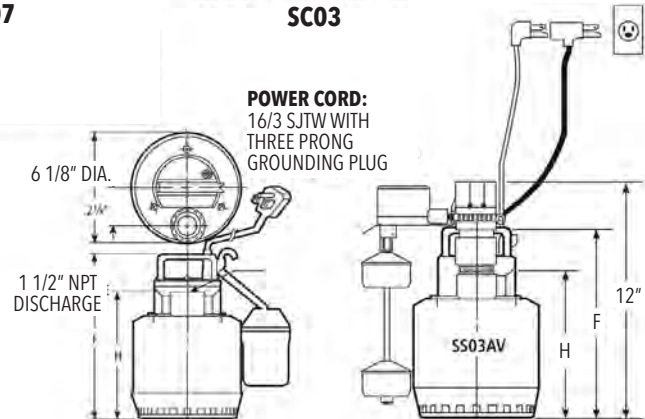

### Performance Chart

Submersible Sump Pumps	NPT Discharge	Solids Handling	Capacities	Maximum Head	Housing Material Construction
SC	1-1/2"	1/2"	70 GPM	37 feet TDH	Cast Iron
SS	1-1/2"	3/8"	55 GPM	34 feet TDH	Stainless Steel

## GSP0311

From Goulds Water Technology

Cast Iron Sump Pump

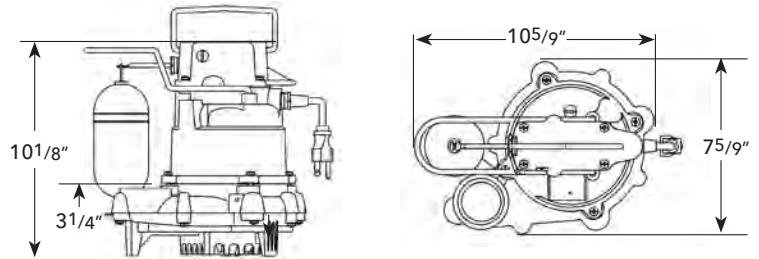

### Specifications

Model Number	Part Number	HP	Volts	Amps	Min. Circuit Breaker	Phase	Float Switch Style	Cord Length	Discharge Connection	Min. On Level	Min. Off Level	Min. Basin Diameter	Max. Solids Size	Shipping Weight
GSP	GSP0311	1/3	115	10	15A	1	Vertical	9'	1-1/2"	7-1/4"	3-1/2"	1'	1/2"	27 lbs
GSP	GSP0311M	1/3	115	10	15A	1	Not Supplied	9'	1-1/2"	-	-	1'	1/2"	27 lbs
GSP	GSP0311-25	1/3	115	10	15A	1	Vertical	25'	1-1/2"	7-1/4"	3-1/2"	1'	1/2"	29 lbs

# WASTEWATER Submersible Sump Pumps

## BBSP Battery Back-up Sump Pump

### BBSP Performance Chart

Discharge Heights	GPH	Battery Life
5'	1380	9 hours
10'	900	9 hours
13'	480	11 hours

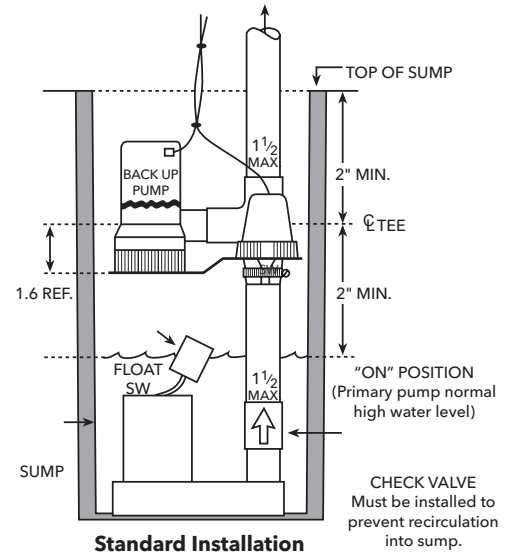

### BBSP2 Performance Chart

Discharge Heights	GPH	Battery Life
5'	2250	7 hours
10'	1500	8 hours
13'	1000	9 hours

## 2WT Sewage Effluent Pump

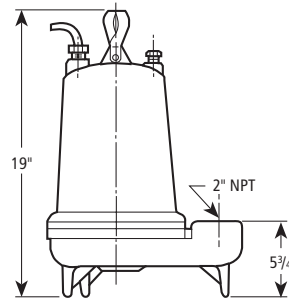
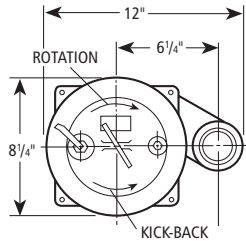

### Specifications

Part Number	HP	Phase	Volts	RPM	Impeller Dia. (in.)	Max. Amps	LRA	KVA Code	Full Load Motor Eff.	Resistance		Wt. (lbs.)	
										Start	Line-Line		
2WT0311	0.33	1	115	1750	4.69	10.7	30.0	M	54	11.9	1.7	63	
2WT0318			208			6.8	19.5	K	51	9.1	4.2		
2WT0312			230			4.9	14.1	L	53	14.5	8.0		
2WT0511	0.5	1	115		5.00	5.00	14.5	31.1	J	55	9.3	1.4	65
2WT0518			208				8.0	19.5	K	51	9.1	4.2	
2WT0512			230				7.3	16.5	J	54	11.7	5.6	
2WT0538		3	200				3.8	12.3	K	75	NA	6.7	
2WT0532			230				3.3	9.7	K	75	NA	9.9	
2WT0534			460				1.7	4.9	K	75	NA	39.4	
2WT0537	575	1.4	4.3		K	68	NA	47.8					
2WT0718	0.75	1	208		5.38	5.38	11.0	39.0	K	65	2.6	1.4	85
2WT0712			230				9.4	24.8	J	57	4.8	2.3	
2WT0738			200				4.1	21.2	H	74	NA	4.3	
2WT0732		3	230				3.6	17.3	J	76	NA	5.6	
2WT0734			460				1.8	8.9	J	76	NA	22.4	
2WT0737			575	1.5			7.3	J	71	NA	29.2		
2WT1018	1	1	208	5.75	5.75	14.0	39.0	K	65	2.6	1.4	85	
2WT1012			230			12.3	30.5	H	60	4.3	1.8		
2WT1038			200			6.0	21.2	H	74	NA	4.3		
2WT1032		3	230			5.8	17.3	J	76	NA	5.6		
2WT1034			460			2.9	8.9	J	76	NA	22.4		
2WT1037			575			2.4	7.3	J	71	NA	29.2		

## Genuine Bell & Gossett Parts

When replacing parts in your customers' B&G booster or other hydronic specialties, don't settle for anything other than genuine B&G parts. You owe it to your customers and to yourself to do it right the first time.

Bell & Gossett parts are designed and engineered strictly for the Bell & Gossett boosters. Substitute parts may seem to cost less. But more often than not, they actually cost a lot more, when they do not hold up on the job. Then you are faced with callbacks and your reputation is at stake.

So why risk having to replace a replacement part? Stick with the real thing – from Bell & Gossett.

Visit our website at  
[www.bellgossett.com](http://www.bellgossett.com)

Go to ESP Plus and click on Sizing & Selection Tools to use ESP Parts, to view an exploded drawing and bill of material.



**B&G designs our own motors to exacting circulating pump specifications.**



**B&G bearing assembly bracket. Restores pump to like new conditions.**



**B&G flexible spring coupler dampens vibration and noise.**

## The Little Red Schoolhouse® - Training the Industry



Bell & Gossett has long been known for its dedication to training. The "Little Red Schoolhouse" has graduated over 60,000 students since it was founded in 1954.

Graduates from the "Little Red Schoolhouse" may be found throughout North America, Europe, Africa, Asia and Australia.

For applications to attend these seminars, please contact a Bell & Gossett Representative in your area. They will have the schedule dates for all seminars and will make all the arrangements for you. As a service and a continuing educational source to the HVAC industry, these seminars are offered free of charge. IACET certified CEU credits are awarded for each seminar.

Seminars currently offered are:

- Modern Hydronic System Design - Basic\*
- Modern Hydronic System Design - Advanced\*
- Design & Application of Water Based HVAC Systems
- Large Chilled Water System Design\*
- Pump Service & Maintenance School
- Steam Systems Design & Applications
- Steam System Operation & Maintenance
- Plumbing Systems Design

\* The USGBC has approved the technical and instructional quality of the Modern Hydronic Heating Systems - Basic Seminar (15 GBCI CE Hours) and the Large Chilled Water Design Seminar (11 GBCI CE Hours). These courses are approved for GBCI Continuing Education Hours towards LEED Credential Maintenance Programs.

We value your feedback. Please take our 3 question survey at [bellgossett.com/survey](http://bellgossett.com/survey) to let us know how we are doing.



Xylem Inc.  
8200 N. Austin Avenue  
Morton Grove, Illinois 60053  
Phone: (847) 966-3700  
Fax: (847) 965-8379  
[www.bellgossett.com](http://www.bellgossett.com)

Bell & Gossett is a trademark of Xylem Inc. or one of its subsidiaries.  
© 2017 Xylem Inc. A-50S June 2017