

## INSTALLATION AND OPERATING INSTRUCTIONS

### APPLICATION

The *i-Link* series multi-zone circulator controller is operated by low voltage thermostats or any other low voltage controllers having an SPST switching action.

The *i-Link* controller provides intermediate switching to permit up to six circulators and a boiler operating control in a multi-zone hydronic heating system.

Intelligent Linking System (*i-Link*) allows unlimited zone expansion with additional *i-Link* controllers. Field selectable priority with protection timer prevents freeze-ups in the event of a priority zone failure.

Unique power surge protection to avoid damage to the unit and ensure continuous control operation.

The panel provides EZ screwless terminal blocks for connections to the thermostats. LED indicators on the front panel provides functional status and easy troubleshooting. In addition, a system circulator is turned on whenever any zone calls for heat.

### FEATURES

- Front panel indicator lights
- Field selectable priority
- Priority timer for protection of a priority zone malfunction and prevention of freeze-ups in the heating zones.
- Unlimited zone expansion
- Capable of turning on extra system circulator
- Addition features for SP-84/85/86: Manual priority override(bypass) for each of the secondary zone
- Isolated End Switch
- Compact and modern design
- Fuse protection
- Power surge protection
- Safety design with all electronic components hiding behind the enclosure
- Simplified wiring
- Contractor friendly PCB layout
- High Capacity Transformer
- Easy-Connect Terminals/Screwless Terminals for Thermostat Connections
- 24VAC transformer output with common terminal provides compatibility with electronic thermostat
- Universal thermostat compatibility
- 100% Factory Tested
- Extended 3 year warranty

### SPECIFICATIONS

Model:	SP-82	2 Zone Switching Relay
	SP-83	3 Zone Switching Relay
	SP-84	4 Zone Switching Relay
	SP-85	5 Zone Switching Relay
	SP-86	6 Zone Switching Relay
Power Supply:	120 VAC, 50/60Hz	
Dimensions:	6 3/8"(W) x 6 5/8"(H) x 2 3/4"(D)	
Electrical Switch Rating:	10 A 1/3 HP @ 120VAC	
Thermostat Anticipator Setting:	0.18 A	
Enclosure:	Flame Retardant Plastic 94V0	
Shipping Weight:	SP-82/83	3 lbs.
	SP-84/85/86	4 lbs.

### CAUTION!

1. To prevent electrical shock hazard, disconnect power supply before installing.
2. All wiring must comply with national and local electrical codes, ordinances, and regulations.  
Never connect the load terminals to a load that takes more current than the amount listed for the relay in the electrical ratings.
3. Azel Technologies is not responsible for damages resulting from misuse of its products.
4. 10-18 gauge wire is recommended for 120 VAC connections;  
12-22 gauge wire is recommended for thermostat connections.
5. This literature is provided for informational purposes only.

### MOUNTING

Mount the *i-Link* controller to a suitable surface. Slotted keyholes and standard holes are provided for mounting purposes.

### ROUGH-IN WIRING

Loosen the screws on the top and bottom of the enclosure and remove the wiring covers by swinging them away from the base(grey color) with the edges of the covers as pivot(see Figure 1).

The base has standard 7/8" (22mm) knockouts which accept common wiring hardware and conduit fittings. Before removing the knockouts, check the wiring diagrams and use the chamber with common voltages.

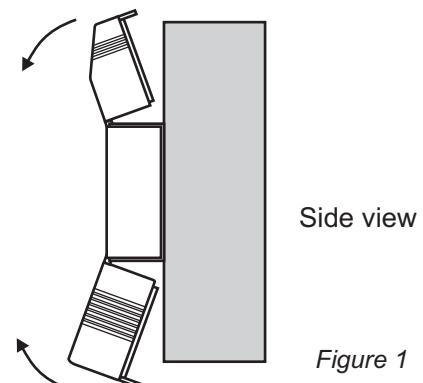

## DOMESTIC HOT WATER PRIORITY OPERATION

When zone 1 priority switch is set to **ON**, zone 1 (domestic hot water zone) has priority control over zone 2 to 6 (heating zones). If zone 1 is calling for heat, zone circulators 2 to 6 are disabled until zone 1 domestic hot water demand is satisfied.

When zone 1 priority switch is set to **OFF** (factory setting), all zones operate independently of each other.

When zone 1 priority switch is set to **TIMER** (Priority Protection Timer mode), if the priority zone calls for domestic hot water for more than one hour (eg. In case of a priority zone failure such as a faulty indirect water heater controller keeps calling for heat or leaking situation), all the heating zones (2 to 6) are released from locking out and they are returned to normal operation. This feature helps prevent freeze-ups in the event of zone 1 failure. Once the priority zone 1 is satisfied, the priority timer is reset to allow priority for another one hour.

## MANUAL PRIORITY OVERRIDE (SP-84/85/86)

When zone 1 priority switch is set to **ON** and the priority circulator 1 is actuated by the thermostat, circulators for zone 2, 3, 4, 5 or 6 will not operate if they are set as Manual Priority Override - **OFF** (factory setting) by the DIP switch. If they are set as Manual Priority Override - **ON**, they operate independently from circulator 1.

## i-Link Zone Expansion

**i-Link** controller can be expanded to unlimited number of zones with additional **i-Link** controllers. Simply connect terminals "1 2 3 4" of the "Master" unit to terminals "1 2 3 4" of the "Slave" unit with 18AWG wires. More units can be connected in the similar manner. Use the Master/Slave Switch to define the unit as "Master" or "Slave". The priority zone of the "Master" unit (if zone 1 priority switch is set to **ON** or **Timer**) will turn off all other zones of the "Slave" units. After expansion, all the units will act as a single unit. This means only one set of X-X (End Switch) terminal is needed to connect to the "TT" on the boiler control and only one connection to system circulator is required. Factory default setting is "Master".

## L.E.D. SYSTEM STATUS INDICATION LIGHTS:

**RED** light indicates that the thermostat is calling for heat and the corresponding circulator is actuated.

**GREEN** Power light indicates presence of power supply.

**GREEN** flashing Priority Timer light indicates one hour priority timer is expired and all heating zones are released from locking out. All zones can operate independently.

## ELECTRONIC THERMOSTATS

ALL **i-Link** controls are compatible with 2, 3 or 4 wire type thermostats. 24VAC output can be used to supply power to the thermostat. For thermostats requiring the 24VAC Common, simply connect C terminal from the thermostat to COM terminal on the 24VAC output.

Azel D-135 thermostat is recommended for use with **i-Link** Controls.

## NOTE ON WIRING INSTRUCTIONS

SP-86 and SP-83 units are used as examples on the wiring diagrams. SP-82/84/85 units can be wired in the same manner.

## TERMINAL DESCRIPTION

### Line Voltage Terminals

N	120 VAC Neutral Terminal Input
L	120 VAC Hot Terminal Input
ZC	Usage depends on Cold start or Tankless Coil Application. Refer to wiring diagrams for details.
ZR	Usage depends on Cold start or Tankless Coil Application. Refer to wiring diagrams for details.
SYS PMP/N	L 120 VAC System Circulator Power
ZONE 1/N	L Zone 1 120VAC Circulator Power
ZONE 2/N	L Zone 2 120VAC Circulator Power
ZONE 3/N	L Zone 3 120VAC Circulator Power
ZONE 4/N	L Zone 4 120VAC Circulator Power
ZONE 5/N	L Zone 5 120VAC Circulator Power
ZONE 6/N	L Zone 6 120VAC Circulator Power

### Dry Contact Terminals

X X	Dry Contact End Switch
-----	------------------------

### Low Voltage Terminals

OUTPUT/COM	24 VAC transformer common
OUTPUT/24VAC	24 VAC transformer hot
ZONE EXPANSION/1 2 3 4	ZONE expansion to additional <b>i-Link</b> Controls

### THERMOSTATS

R/T1	Zone 1 24VAC Thermostat Hot Terminal
W/T1	Zone 1 Thermostat Switching Terminal
R/T2	Zone 2 24VAC Thermostat Hot Terminal
W/T2	Zone 2 Thermostat Switching Terminal
R/T3	Zone 3 24VAC Thermostat Hot Terminal
W/T3	Zone 3 Thermostat Switching Terminal
R/T4	Zone 4 24VAC Thermostat Hot Terminal
W/T4	Zone 4 Thermostat Switching Terminal
R/T5	Zone 5 24VAC Thermostat Hot Terminal
W/T5	Zone 5 Thermostat Switching Terminal
R/T6	Zone 6 24VAC Thermostat Hot Terminal
W/T6	Zone 6 Thermostat Switching Terminal

## TYPICAL WIRING DIAGRAMS

### COLD START (LOW THERMAL MASS) BOILER APPLICATION

#### OPERATION

When zone thermostat calls for heat, the appropriate circulator is actuated and the isolated end switch X-X will start the boiler. A system circulator is also actuated if it is installed.

#### JUMPER PLACEMENT

The jumper (factory installed) should be placed between terminal ZC and ZR. Connect isolated end switch X-X to T-T terminals on boiler control.

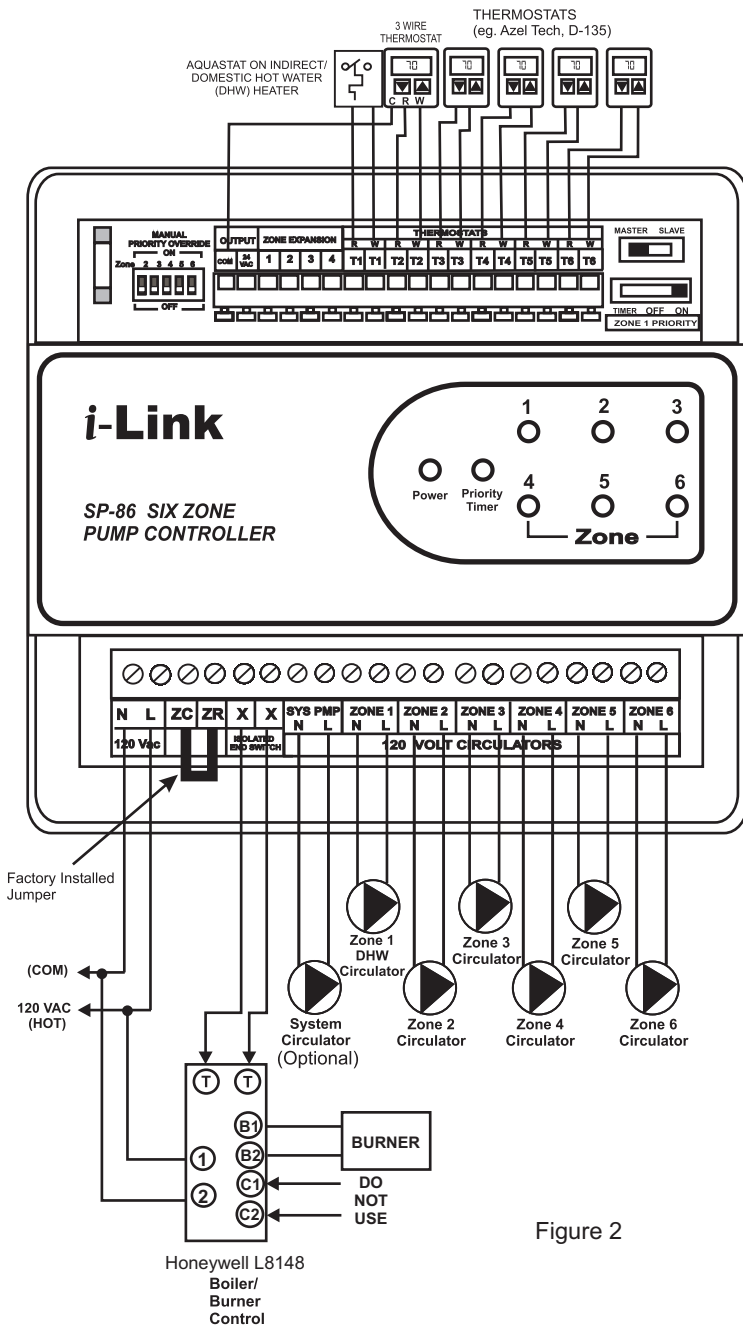

### TANKLESS COIL (HIGH THERMAL MASS) BOILER APPLICATION

#### OPERATION

When zone thermostat calls for heat, the appropriate circulator is actuated and the boiler is started. If the boiler temperature drops below the low limit, all circulators will cease until the boiler temperature is increased above the low limit.

#### JUMPER PLACEMENT

Remove the factory installed jumper between terminals ZC and ZR.

Connect terminal ZC to ZC terminal on boiler (aquastat) control.

Connect terminal ZR to ZR terminal on boiler (aquastat) control.

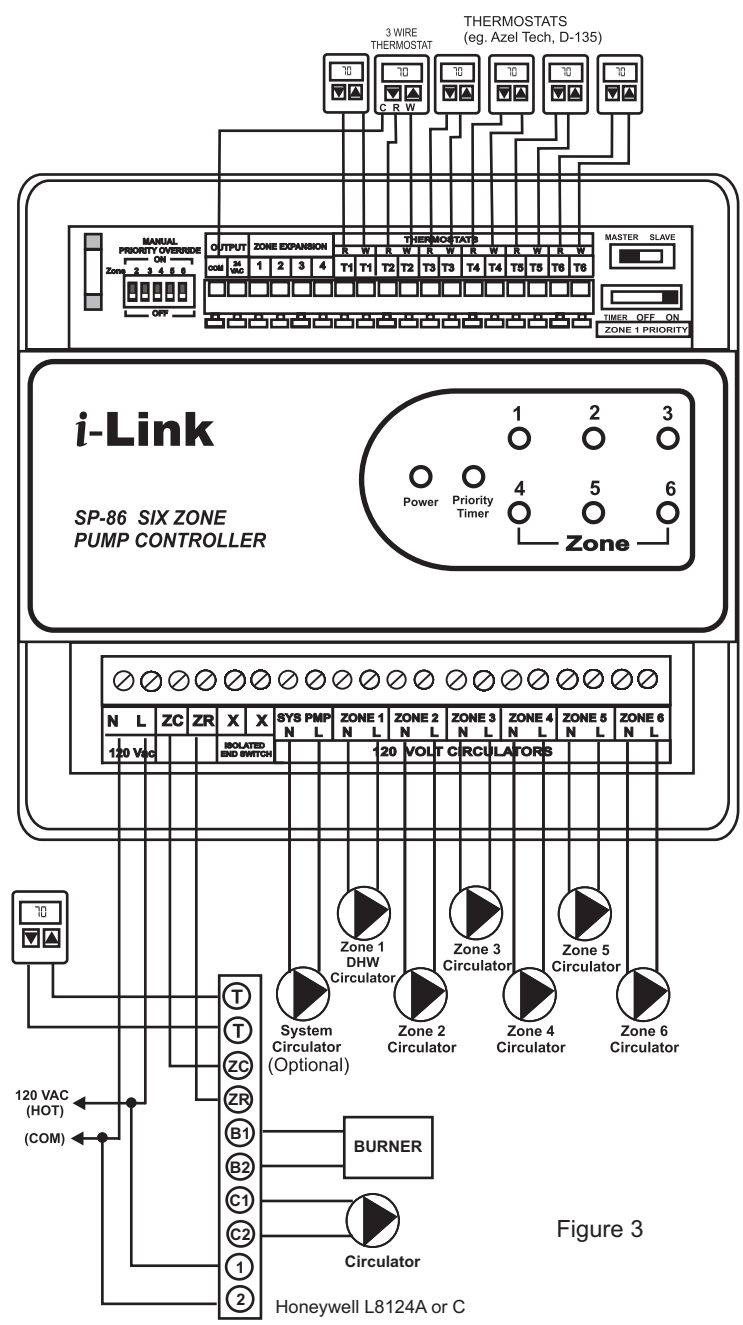

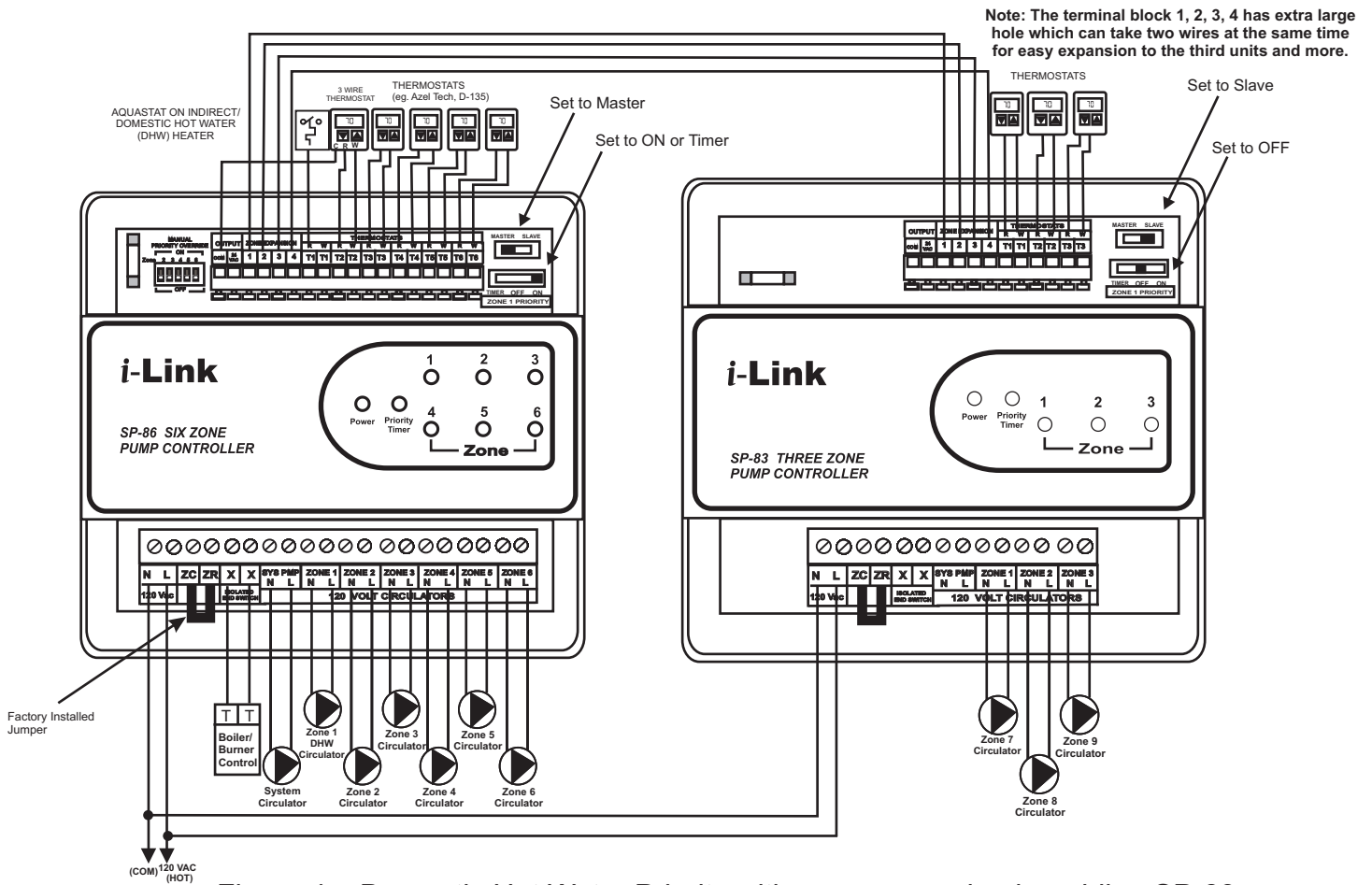

Figure 4 Domestic Hot Water Priority with zone expansion by adding SP-83.

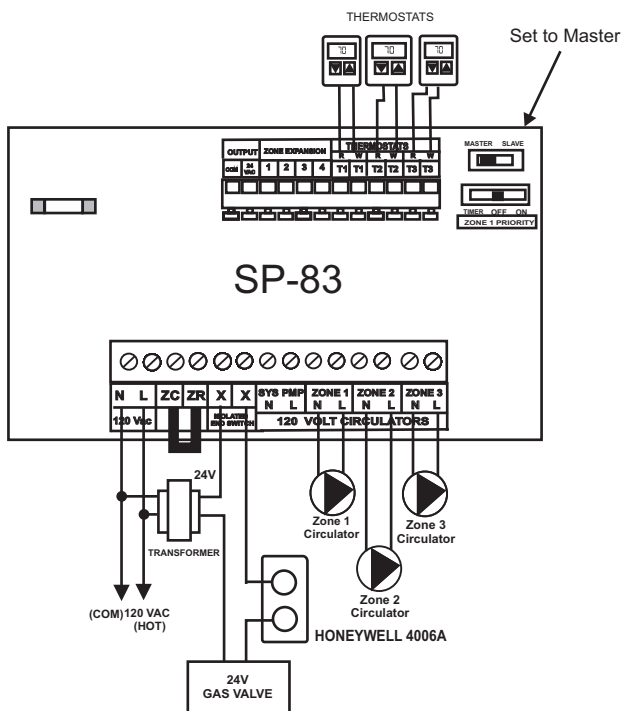

Figure 5 24VAC High Limit & Gas Valve

## TROUBLE SHOOTING

When 120VAC is supplied to **i-Link** controllers, the green indicator light should be on. When the thermostat calls for heat, both the red indicator light and the circulator should be on.

- **If the green light is on and the circulator cannot be turned on by the thermostat (red light is off)**, remove the thermostat and put a piece of wire across the thermostat terminals (R/T and W/T) to simulate thermostat calling for heat. If the circulator can be turned on along with the red light, then check the thermostat for functionality.
- **If both green light and red light are on and the circulator cannot be turned on**, re-tighten the screws for the jumper on terminal ZC and ZR in case of Cold Start Boiler Application and try again.
- **If red light is on all the time**, check the thermostat for functionality. Remove the thermostat from the **i-Link** controller and put a piece of wire across R/T and W/T terminal to simulate the thermostat calling for heat. If everything works properly, then the thermostat is faulty.
- **If the green light is off**, check the fuse and the presence of 120VAC power supply.

**AZEL TECHNOLOGIES INC.**

[www.azeltec.com](http://www.azeltec.com)

Please visit our website for other products

P.O. Box 53138  
 10 Royal Orchard Blvd.  
 Thornhill, Ontario, Canada L3T 7R9  
 Ph: 905-223-5567 Fax: 905-223-3778  
 Email: [info@azeltec.com](mailto:info@azeltec.com)