

Measurement of the Ignition Temperature of Wood

LI YUDONG

Research Institute for Wood Industry
Chinese Academy of Forestry
Beijing 100091
People's Republic of China

DOUGAL DRYSDALE

Unit of Fire Safety Engineering
The University of Edinburgh
Edinburgh EH9 3JL
U.K.

ABSTRACT

This paper describes an experimental investigation into the piloted ignition of four species of wood, under radiant heat fluxes of 15 - 32 kW/m². The surface temperature of horizontal samples at the firepoint (the onset of sustained ignition) was measured by means of a surface mounted thermocouple. The time to ignition was also recorded. The ignition temperature could be measured with some degree of precision, although at the lower heat fluxes, the surface temperature first reached a plateau before increasing to the firepoint.

The apparent firepoint temperature at the lower irradiances is much higher than the values obtained at 24 kW/m² and above. An explanation for this phenomenon is suggested and its implications for assigning a "firepoint temperature" to wood is discussed.

Introduction

With the development of fire science over the past two decades, the engineering approach to fire safety has become a realistic goal. The fire behaviour of combustible materials is now much better understood and the development of the new generation "reaction-to-fire tests" offer the opportunity to obtain data which can be used in fire risk assessment. Thus, the Cone Calorimeter (1) permits the rate of heat release characteristics of a material to be determined. While this is arguably most significant parameter in the developing fire, ignitability, or "ease of ignition" is still of major importance. Ignition criteria must be established and the relevant material properties determined so that the conditions that may lead to ignition can be predicted on the basis of a suitable ignition model.

Ignition has been the subject of many studies (2,3). However, it is surprising that the phenomenon of piloted ignition (in which the evolved vapours are ignited by a small flame or spark) and its relationship to the "firepoint" has not received the attention it deserves. Several empirical ignition criteria have been proposed in the past, such as a critical level of radiant heat flux and a critical value of the product (absorbed radiance x time to ignition). While these criteria are relatively easy to obtain experimentally, they are apparatus dependent and unsuitable in engineering analysis. Of more value is the critical surface temperature at the firepoint, a parameter which has been measured for a number of thermoplastics (4) and may be considered as a satisfactory criterion for the minimum conditions for piloted ignition to lead to sustained flaming (5). In principle, a simple heat

transfer model can be used to assess whether or not the firepoint condition has been achieved (5,6).

Early investigations of the piloted ignition of wood (e.g. 7) drew attention to the existence of a critical radiant heat flux for ignition and deduced the existence of a minimum temperature for ignition. However, very few direct measurements have been made, and values in the range 300 - 540°C have been reported (6,8). This wide band of uncertainty is due to a number of factors, including (i) the difficulties associated with the measurement itself; (ii) the uncertainty in interpreting the temperature-time records; and (iii) problems associated with the pilot ignition of the fuel vapours. Atreya (8) established a procedure for measuring the surface temperature and showed how the results could be interpreted, and Thomson and Drysdale (4) drew attention to the need to use a substantial ignition source (such as a small flame) to ignite the vapours at the firepoint. A hot wire ignition source (e.g. 9) is inadequate.

Recent studies by Atreya *et al.* (8) and Janssens (10) using a variety of species of wood indicate that the firepoint temperature can be determined, with an accuracy of $\pm 20^\circ\text{C}$. Atreya found that the measured surface temperature at ignition for horizontal and vertical samples of mahogany lay between 350 and ca. 390°C in the range of irradiances 18 - 50 kW/m². It was noted that there was a tendency for T_{ig} to be higher at the lower heat fluxes and that the scatter was particularly large for horizontal samples. Janssens (10) measured T_{ig} for six species of wood in the horizontal configuration at 25, 30 and 35 kW/m², but did not observe any dependency on the level of irradiation. He reported that the scatter was "within 20°C of a species-dependent mean (Table 1) and is usually much smaller".

Table 1 Firepoint temperatures obtained by Janssens (10).

Wood Species		Density (g/cm ³)	Ignition Temperature (°C)
Western Red Cedar	softwood	0.33	354
Redwood	"	0.43	364
Radiata pine	"	0.46	349
Douglas fir	"	0.465	350
Victorian ash	hardwood	0.64	311
Blackbutt	"	0.81	300

The present study was undertaken to obtain additional data on T_{ig} for horizontal samples of wood over a range of heat fluxes in an attempt to examine the irradiance-dependency further.

Experimental

Four species of sawn timber were obtained from a local timber supplier, two soft woods (white pine and western red cedar) and two hard woods (Brazilian mahogany and obeche). The samples were cut to the size required in the ignition apparatus (64mm square by 18mm thick), dried to constant weight at 105°C in an oven, then stored in a desiccator. Their densities are given in Table 2.

Fine chromel-alumel thermocouples, prepared with 0.05mm diameter wire, were used. The hot junction was mounted on the surface of the sample using the method perfected by Atreya (11). A very fine, shallow incision was made at the centre of the wood surface and the thermocouple junction slipped below the raised sliver of wood. This was then secured with a minimum amount of wood glue necessary to keep the thermocouple junction in place. Pressure was applied until the glue set and the sample returned to the desiccator until it was required. Further preparation of the sample involved wrapping it in aluminium foil and exposing a disc 55mm in diameter on the upper surface from which the foil was peeled away. The sample was then fitted into a stainless steel shield which exposed a disc 55mm in diameter: this shield was a permanent fixture in the apparatus.

The apparatus is shown in Figure 1. A conical heater (Stanton-Redcroft Ltd.), identical to that used in the ISO Ignitability Test, acted as the source of the radiant heat flux which was varied in the range 15 to 32 kW/m² by changing the applied voltage. The radiant intensity in the plane of the sample surface was measured immediately before each experiment with a Gardon type heat flux meter (Medtherm).

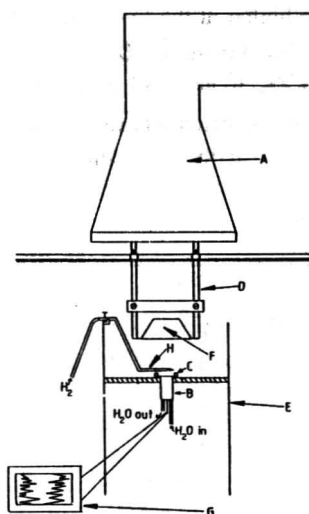

Figure 1. Schematic diagram of the apparatus. A, extract hood; B, Medtherm heat flux meter; C, guide rails; D, support for conical heater; E, support frame; F, conical heater; G, pen chart recorder; H, hydrogen pilot flame. (4)

In each experiment, the temperature of the heater was allowed to stabilise before the sample was placed in the sample holder. The thermocouple output was recorded continuously by means of a multi-channel chart recorder (Watanabe MC461). A pilot ignition source, consisting of a small hydrogen diffusion flame burning at the end of a stainless steel tube (2mm internal diameter) was passed over the centre of the sample at a height of 5mm at 5 second intervals once the surface temperature of the wood had achieved 250°C.

Results and Discussion.

The surface temperature at ignition (T_{ig}), and the time to ignition (t_{ig}) for each of the four species of wood were measured at 5 irradiance levels from 15.4 to 31.7 kW/m² (Table 2). Flaming ignition was observed for all samples tested within this range, with the exception of the white pine which did not always ignite at the lowest heat flux. The apparent increase in T_{ig} with decreasing heat flux was confirmed, but the results fall clearly into two regimes.

At 24 kW/m² and above, the surface temperature is found to rise at a decreasing rate until flame becomes established at the surface. At this point, the surface temperature climbs very steeply, allowing the ignition event to be timed precisely (Figure 2). Prior to sustained ignition, transient ignition, or "flashing", was normally observed: this was recorded as discontinuities in the otherwise smooth, monotonic increase in temperature. The ignition temperatures were deduced by extrapolating the continuous curve forward to the point of sustained ignition (4,8). Typical results for mahogany are shown in Figure 2. Firepoint temperatures were easily deduced and are shown in Table 2. As can be seen, these lie in the vicinity of 350 -360°C, although white pine was found to have substantially higher values.

At 19.7 kW/m² and below, the surface temperature/time curves were significantly different in that the temperature reached a plateau in the region 360 - 380°C before rising further to the onset of sustained ignition at a higher temperature (average > 400°C). Visual observation of the samples at these lower heat fluxes indicated the onset of glowing combustion at the surface well before flaming was initiated. Glowing was observed to start near the centre of the sample and spread outwards. The recorded surface temperature began to rise from the plateau value when the glowing zone reached the location of the thermocouple. Under these circumstances, the surface temperature measured at the onset of flaming combustion is much higher and the scatter greater than that observed at the higher heat fluxes (Table 2). The oxidation of the char appears to participate in the subsequent development towards flaming ignition.

In simple models of piloted ignition, it is assumed that the material is inert, at least until the firepoint temperature is reached (5,6). The development of a plateau in these low heat flux experiments provides the opportunity to examine this assumption for wood. If it is assumed that the wood is "inert" (which is clearly incorrect) and that the surface of the char acts as a black body ($\epsilon = 1$), then at equilibrium, with an imposed heat flux of 15kW/m², the surface temperature will be determined by the following expression:-

$$\epsilon\sigma(T_p^4 - T_o^4) + h(T_p - T_o) = 15$$

where T_p and T_o are the plateau temperature and the ambient temperature respectively, and h is the appropriate convective heat transfer coefficient. With $h = 0.01$ kW/m².K, $T_p = 400^\circ\text{C}$, some 40 - 50°C higher than the observed plateau temperatures at 15.4kW/m². This is consistent with a char emissivity (ϵ) of 0.53, but this seems unreasonably low. It is

likely that the temperature of the plateau is suppressed by endothermic char-forming processes.

Table 2 Ignition data (present study).

Species (Density, g/cm ³)	Heat flux (kW/m ²)	Average T _{ig} (°C)	Standard deviation	Plateau Temp. (°C)	Standard deviation	Average t _{ig} (s)	Standard deviation	No. of Samples Tested
Mahogany (0.54)	15.4	465	21	365	3	850	80	7
	19.7	427	14	385	3	324	39	7
	24.0	364	8	-	-	90	7	8
	28.7	360	6	-	-	60	7	7
	31.7	353	10	-	-	38	4	9
Western Red Cedar (0.28)	15.4	450	19	366	1	583	95	6
	19.7	431	12	379	8	216	29	8
	24.0	365	4	-	-	57	8	7
	28.7	346	6	-	-	30	3	9
	31.7	354	7	-	-	23	1	8
Obeche (0.35)	15.4	497	74	359	7	684	121	9
	19.7	442	30	361	18	176	39	7
	24.0	364	8	-	-	60	5	6
	28.7	344	14	-	-	39	4	8
	31.7	340	12	-	-	29	3	8
White Pine (0.36)	15.4	446	13	354	4	1094	162	8
	19.7	411	25	380	11	257	69	11
	24.0	397	3	-	-	95	18	7
	28.7	387	4	-	-	48	4	7
	31.7	375	17	-	-	32	3	9

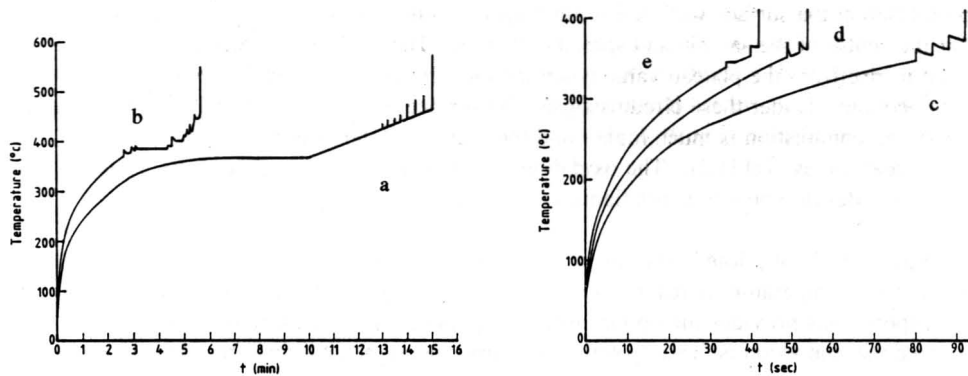

Figure 2. Typical temperature-time records for Mahogany samples at (a) 15.4; (b) 19.7; (c) 24.0; (d) 28.7; and (e) 31.7kW/m².

During a long exposure time (at low heat flux) a considerable thickness of char builds up, providing increasing protection to the underlying virgin wood. Given that char formation

is still occurring at depth, an additional heat flux is required to generate the necessary flow of combustible volatiles at the firepoint. It is suggested that this is generated by the surface oxidation of the char. Thus, the surface temperature recorded when flaming is initiated is not meaningful. It will be determined by the char oxidation process, perhaps combined with the continuing radiant heating of the surface.

It should be noted that the present results indicate that the surface temperature at the firepoint at the higher heat fluxes is close to the plateau temperatures measured at the low heat fluxes. This may be fortuitous and further data are necessary before any firm conclusions can be drawn, but it would appear that char oxidation plays an important role in the ignition of wood.

Although the assumption that wood behaves as an inert material until the firepoint is reached is clearly untenable, its application in simple heat transfer models of ignition will give very conservative results if the firepoint temperature is assumed to be (of the order of) 350°C.

Conclusion.

The results reported in this paper show that the oxidation of the surface layer of char during the radiative heating of samples of wood may play an important role in the ignition process.

References.

1. American Society for Testing and Materials, E 1354-90: Standard test method for heat and visible smoke release rates for materials and products using an oxygen consumption calorimeter. (ASTM, Philadelphia, PA, 1990).
2. A.M. Kanury, Fire Research Abstracts and Reviews, **14** 24-52 (1972)
3. A.M. Kanury, SFPE Handbook, Chapter 1-21 (SFPE, 1988).
4. H.E. Thomson and D.D. Drysdale, Fire & Materials **11** 163-172 (1987).
5. H.E. Thomson, D.D. Drysdale and C.L. Beyler, Fire Safety Journal **13** 185-196 (1988).
6. M Janssens, Fire and Materials **15** 151-167 (1991).
7. D.L. Simms, Combustion and Flame **7** 253-261 (1963).
8. A. Atreya, C. Carpentier and M. Harkleroad, 1st International Symposium on Fire Safety Science (Hemisphere Publishing Corporation, 1986) pp. 97-110
9. T Kashiwagi, Combustion and Flame **34** 231-244 (1979).
10. M.L. Janssens, "Fundamental Thermophysical Characteristics of Wood and their Role in Enclosure Fire Growth." PhD Thesis, University of Gent (Belgium) 1991.
11. A. Atreya, "Pyrolysis, Ignition and Fire Spread on Horizontal Surfaces of Wood." PhD Thesis, Harvard University, Cambridge, MA (USA) 1983.