

MAXIPANEL

SIDING PANEL INSTALLATION GUIDE



Read all instructions prior to installing any siding product. Failure to install and finish this product in accordance with all local building codes, regulations and MaxiTile written application may lead to personal injury, affect system performance, violate local building codes, and void the product warranty. We suggest that you read these instructions at least twice.

MAXIPANEL is a fiber-cement exterior siding panel. It will not rot or deteriorate. It is non-combustible, with zero flame spread and zero smoke generation.

MAXIPANEL is available in 4' width and 8', 9', and 10' lengths.

MAXIPANEL is available in several different patterns: Cedar, Smooth, Fiesta Stucco, and V-Groove.

STORAGE AND HANDLING

- **MAXIPANEL** is produced with a factory applied primer, this primer does not provide adequate resistance to moisture in the event the product is allowed to become saturated during storage. If **MAXIPANEL** becomes wet or saturated, allow product to dry before installation.
- Use plastic coverage that is provided with the pallet to keep product dry prior to installation
- Installing wet or damp **MAXIPANEL** may cause shrinkage at butt joints which may produce breakage at corners.
- **MAXIPANEL** must be stored to protect against weather damage. Keep product dry and flat. Maximum height for storage is 5 pallets.
- Product must be carried on edges to avoid breakage or excessive bending.



MaxiTile is not responsible for damage caused by improper storage and/or handling of the product.

PACKAGING

MAXIPANEL is delivered in full pallets.

Nominal Thickness	Width	Length	Weight/pieces	Pieces/Pallet
5/16" (8 mm)	4' (1.22 m)	8' (2.44 m)	78.6 lb (35.72 kg)	50
		9' (2.74 m)	88.4 lb (40.19 kg)	40
		10' (3.05 m)	98.2 lb (44.65 kg)	40
7/16" (11 mm)	4' (1.22 m)	8' (2.44 m)	108.0 lb (49.11 kg)	40
		10' (3.05 m)	135.2 lb (61.40 kg)	30

FRAMING

- **MAXIPANEL** can be installed over braced wood or steel studs, spaced at 16" with a maximum of 24" o.c.
- A weather resistant barrier between the framing and the siding is required. The water resistive barrier must be appropriately installed with penetration and junction flashing in accordance with local building code requirements.
- It is recommended to maintain a minimum width of 1/2" on stringers, in order to provide enough area for the fasteners.
- Do not install MaxiTile products, in any manner that allows contact with standing or running water.
- Framing must be provided at horizontal and vertical edges for nailing.
- **MAXIPANEL** vertical siding must be joined on horizontal studs.

MaxiTile will not assume any responsibility for water infiltration within the wall or wall cavity.

CUTTING

- If power-sawing, use carbide-or diamond-tipped blades. Position cutting station so that wind will blow dust away from user and others in working area.
- Only use power cutting tools in well ventilated areas.
- Use NIOSH approved respirators and goggles for protection when power-sawing.
- For score-and-snap cutting, use a carbide-tipped scoring tool
 - Using a straight edge as a guide, carefully draw the scoring tool several times towards yourself, applying even pressure.
 - Bend upwards and break.
 - Round openings can be made by drilling several holes around the circumference of the desired opening and tapping out the center.
- Snapper tools and Shears can also be used.
- NEVER use a power saw indoors.
- NEVER dry sweep. Use wet suppression or HEPA vacuum.
- For grooved **MAXIPANEL**, follow drawn area to ensure proper cutting.



WARNING: AVOID BREATHING SILICA DUST.

MaxiTile siding products contain respirable crystalline silica, which is known to the State of California to cause cancer and is considered by IARC and NIOSH to be a cause from some occupational sources. Breathing excessive amounts of respirable silica dust can also cause a disabling and potentially fatal lung disease called silicosis, and has been linked with other diseases. Some studies suggest smoking may increase these risks. During installation or handling: (1) work in outdoor areas with ample ventilation; (2) use fiber cement shears for cutting or, where not feasible, use a dust-reducing circular saw attached to a HEPA vacuum; (3) warn others in the immediate area; (4) wear a properly-fitted, NIOSH-approved dust mask or respirator (e.g. N-95) in accordance with applicable government regulations and manufacturer instructions to further limit respirable silica exposures. During clean-up, use HEPA vacuums or wet methods, never dry sweep. For further information, refer to our installation guides and Material Safety Data Sheet available at www.maxitile.com or by calling (800) 338-8453. FAILURE TO ADHERE TO OUR WARNINGS, MSDS, AND INSTALLATION GUIDES MAY CAUSE SERIOUS PERSONAL INJURY OR DEATH.

FASTENER

- Fasteners must be corrosion-resistant, preferably quality hot-dipped galvanized nails. MaxiTile is not responsible for corrosion resistance of fasteners. Stainless steel fasteners are recommended when installing MaxiTile products near the ocean, or in very humid climates. Always check local building codes for additional requirements.
 - Screws shall be self-drilling all weather or stainless steel.
 - For installation into wood stud, use 2" long, 6-penny nails, with minimum 0.125" shank and 0.265" head.
 - For installation into metal stud, use CD Drill No. 8 x 1 ¼" in length.
 - Staples are not allowed.
 - Use nails for siding 2" long, with a piston rod 0.113" minimum in diameter and a 0.270" head.
- Do not use aluminum fasteners, staples, or clipped head nails*
- Consult applicable code compliances report for correct fasteners type and placement to achieve specified design wind loads.
 - Nails can be applied using a smooth head hammer or a pneumatic nail gun with flush attachment so nails are not over-driven.
 - If hand nailing, first pre-drill the holes to avoid accidental breakage.
 - Nails must always hit studs, penetrating a minimum of 1" into stud. If nails hit sheathing only, warranty may be void.
 - Drive fasteners perpendicular to siding and framing.
 - The use of a pneumatic nail gun with flush attachment is recommended.
 - Fastener heads must hold the panel without over-driving. In the event of over-driven nails, caulk nail hole and re-nail.
 - Fastener heads should fit snug against siding (no air space).
 - Do not over-drive nail heads or drive nails at an angle.
 - If nail is countersunk, caulk nail hole and add a nail.
 - For wood framing, under driven nails should be hit flush to the panel with a hammer (For steel framing, remove and replace nail).



Remember: Fastener always must be attached to structural framing members.

NOTE: Published wind loads may not be applicable to all areas where Local Building Codes have specific jurisdiction. Consult MaxiTile Technical Assistance if you are unsure of applicable compliance documentation

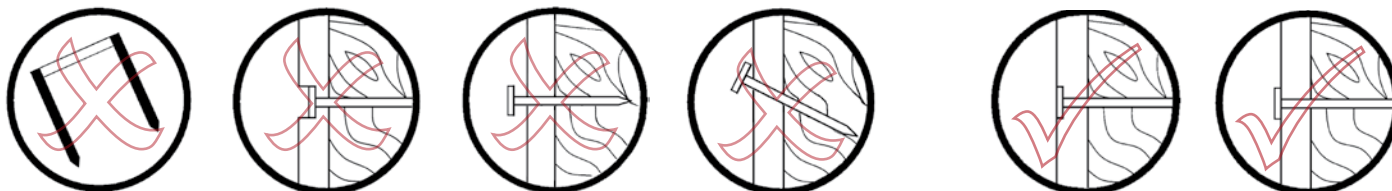

INSTALLATION

- **MAXIPANEL**, vertical siding can be installed into studs spaced a maximum 24" on center. (Illustration shows typical 16" on center framing.)
- Instructions for the installation of **MAXIPANEL** must be followed with acknowledgment of Local Building Codes, with a minimum of 6" clearance between the edge of the **MAXIPANEL** and the lowest bound extreme of the grade.
- Maintain the necessary clearance between the **MAXIPANEL** and roofs, covers, corridors, stairs, and garage entrances, in accordance with Local Building Codes.
- The use of a level ledger board or starter strip for all vertical installation is required, in order to square, level, and hold the weight of the panel for proper fastening
- Begin fastening at the edge and work across the face of the **MAXIPANEL**.
- Fasteners must be placed at 2" minimum away from corners and 3/8" from **MAXIPANEL**

edges. Perimeter and field areas must be fastened as depicted by the illustration on the following page.

- It may be necessary to use a double stud at some joints to provide sufficient nailing surface. With grooved **MAXIPANEL** avoid nailing through the grooves.
- Leave 1/8" gap between **MAXIPANEL** and the corners
- Joint Treatment:
 - For horizontal joints, install type "Z" flashing at all horizontal joints.
 - For vertical joints, type "T" or "H" molding may be applied, wood molding, or elastomeric sealants may be used. (If using caulk, apply to the edge prior to installing the next panel and fill the joint.)

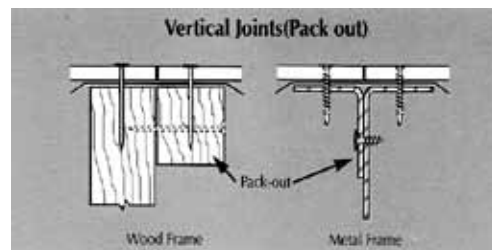
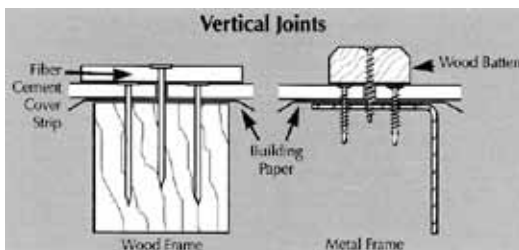
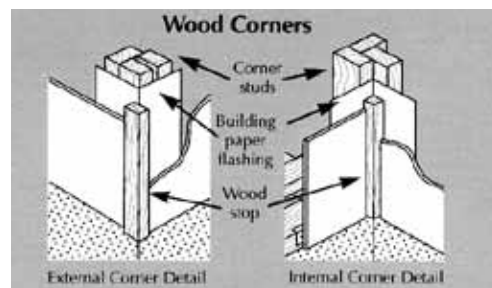
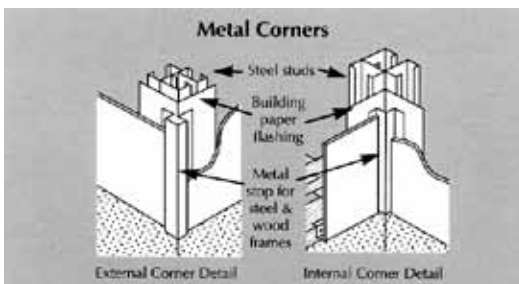
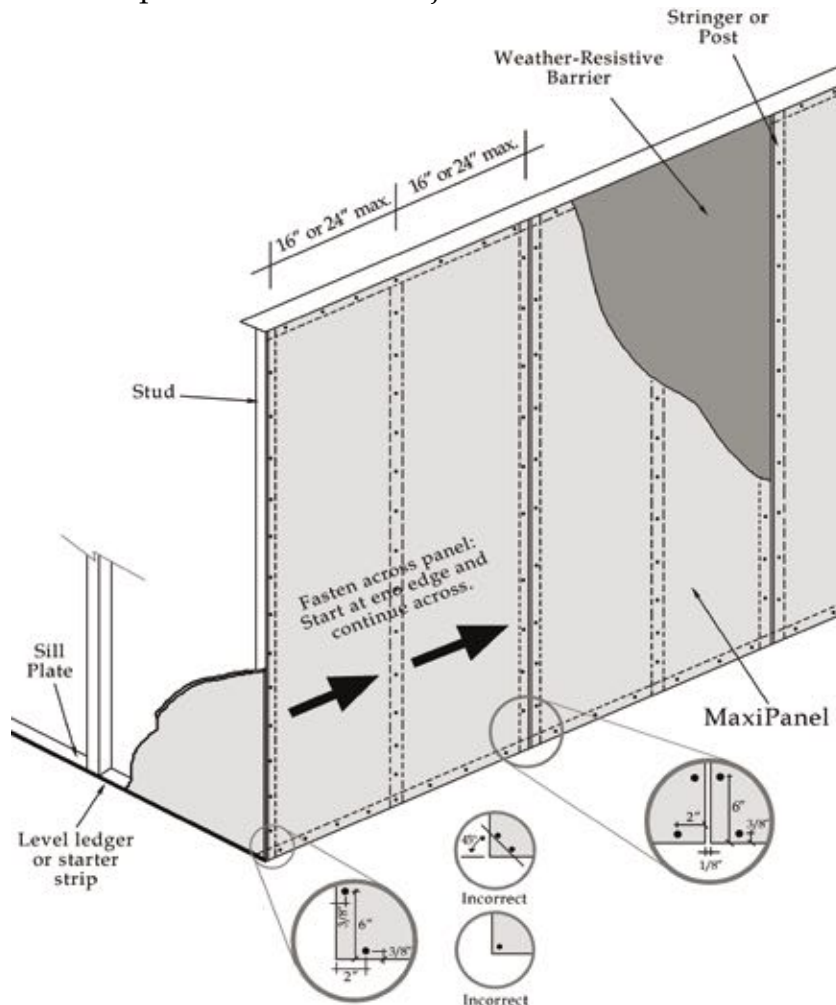

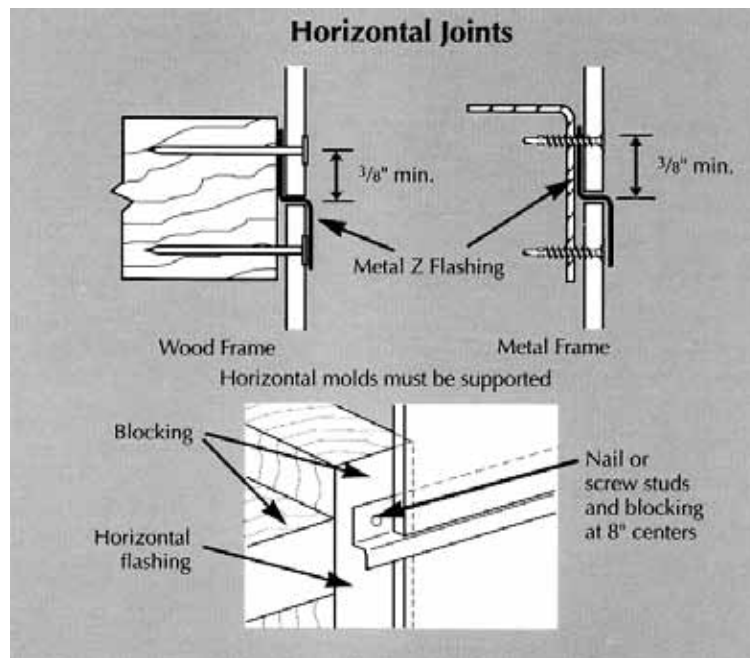

Kickout Flashing:

- Because of the volume of water that can pour down a sloped roof, one of the most critical flashing details occurs where a roof intersects a sidewall.
- The roof must be flashed with step flashing. Where the roof terminates, install a kickout to deflect water away from the siding.
- It is best to install a self-adhering membrane on the wall before the subfascia and trim boards are nailed in place, and then come back to install the kickout.

Finishing Instructions

Repairs

- Repair chips or small dents with acrylic mortar.
- Apply primer to repaired areas and then paint.

Caulk

Use a high quality paintable exterior grade elastomeric sealant that complies with ASTM-C-834 or ASTM-C-920 (grade NS, Class 25) regulations. The sealant must be applied in accordance with sealant manufacturer's instructions.

Painting

MaxiTile siding, soffit and trim must be allowed to breathe. Some factory-applied prime or paint on the back is normal, never completely prime or paint the back side, the product does not require this. A small amount of material should be painted and evaluated to ensure satisfaction with the appearance before painting all material needed for job.

Never apply oil-based paints or stain to siding, soffit or trim, the use on unprimed or primed product could result in increase surface roughness, loss of adhesion, cracking or excessive chalk. Stains containing linseed oil are specifically designed for woods and not be suitable for fiber-cement products, primer or unprimed.

MaxiTile neither does nor recommended semi-transparent stain or paint because they can vary in uniformity of appearance and they have not proven durable in exterior exposure and may require application of a refurbishing sealer at regular intervals.

Before applying the finish coat, clean all the fiber-cement products thoroughly. Use a high-quality 100% acrylic paint or primer. Always follow the paint manufacturer's instructions when painting.

If you desire stained fiber-cement product, uses a high-quality 100% acrylic latex stain. Before stained test in small amount of material should be stained and evaluated to ensure satisfaction. Always follow the stain manufacturer's instructions when staining.

All fiber-cement products must be painted once installation, you have up 90 days (3 months) to apply a finish coat on unprimed products and 180 days (6 months) on primed products. For best result with unprimed products, prime first and then finish with exterior-grade topcoats, two coats of paint must be applied on primed products.

Remember all exposed field cut edges should be covered with primer, sealant or paint, the caulk/sealant should be paintable or color matched, it should be compatible with MaxiTile siding and the material used for the trim.

Never apply primer or paint to wet or saturated fiber-cement products. Do not allow paint to freeze. Apply primer or paint when temperature the air and the fiber-cement product is above 50°F (10°C).

MaxiTile will not warrant and does not assume any responsibility for the performance or appearance of field-applied primer and/or prime.

Maximum Wind Loads MaxiPanel

THICKNESS (inches)	FASTENER TYPE	FASTENER SPACING	FRAME TYPE	STUD SPACING (inches)	HEIGHT OF BUILDING (feet)	MAXIMUM BASIC WIND SPEED (mph) FOR EXPOSURE CATEGORY ¹											
						IBC, IRC ²			BNBC ³			SBC ⁴			UBC ⁵		
						B	C	D	B	C	D	< 60 ft	C	D	B	C	D
1/4	4d box 1½ inch long nails ⁶	6 inches on center	2 by 4 Wood ⁸	16	15	140	130	120	150	120	100	135	--	--	120	110	100
					20	140	130	120	150	115	95	130	--	--	120	110	100
					40	140	120	115	140	100	90	115	--	--	120	100	95
					60	140	120	110	130	95	85	110	--	--	120	100	90
					100	130	110	--	100	80	75	--	80	75	110	90	--
200	120	105	--	--	--	--	--	--	--	100	85	--					
5/16	6d common 2 inch long nails ⁷	6 inches on center	2 by 4 Wood ⁸	16	15	140	130	120	150	120	100	135	--	--	120	110	100
					20	140	130	120	150	115	95	130	--	--	120	110	100
					40	140	130	115	140	100	90	115	--	--	120	110	95
					60	140	120	110	130	95	85	110	--	--	120	100	90
					100	130	110	--	100	80	75	--	80	75	110	90	--
200	120	105	--	--	--	--	--	--	--	100	85	--					
5/16, 7/16	No. 8 by 1¼ inch long RPI C-drill screws	6 inches on center	No. 20 gage by 3 5/8 inch by 1 3/8 inch metal C/stud	16, 24	15	140	120	105	150	100	85	115	--	--	120	100	85
					20	110	110	100	140	95	80	110	--	--	120	90	80
					40	110	110	100	120	75	75	100	--	--	110	90	80
					60	100	100	90	110	70	70	95	--	--	100	80	75
					100	100	100	--	90	--	--	--	--	--	95	80	--
200	90	90	--	--	--	--	--	--	--	85	75	--					

1 N/A - not applicable

2 Basic wind speed is the 3-second gust, miles per hour (km/hr), in accordance with IBC Section 1609.3 and IRC Section R301.2.

3 Basic wind speed is the fastest mile speed in accordance with BNBC Section 1609.3.

4 Basic wind speed is the fastest mile speed in accordance with SBC Section 1606.

5 Basic wind speed is the fastest mile speed in accordance with UBC Section 1616.

6 Nails has 0.09-inch-diameter shank and 0.218-inch-diameter head.

7 Nails has 0.125-inch-diameter shank and 0.265-inch-diameter head.

8 Wood specific gravity is 0.42 or higher.

APPROVALS: In accordance with ICC-ES Legacy Report ESR-1381, MAXIPANEL is compliance with the following codes: 2006 International Building Code (IBC) and 2006 International Residential Code (IRC). MAXIPANEL lap siding is also recognized for application in the following: City of Los Angeles Research Report No. 25252, State of Florida listing FL # 11009, U.S. Dept. of HUD Materials Release 1338, Texas Department of Insurance Product Evaluation EC-56, and listing in Wildland Urban Interface Handbook (WUII). These documents should also be consulted for additional information concerning the suitability of this product for specific applications.

Additional Installation Information, Warranties, and Warnings are available at www.maxitile.com

MaxiTile, Inc.
 849 East Sandhill Avenue
 Carson, CA 90746
 Ph: 310/217-0316
 Fax: 310/515-6851



1-800-338-8453

Email:
customer.service@maxitile.com

Website:
www.maxitile.com