

MOTOR REPAIR SUPPLIES



 **ESSEX**
BROWNELL

WARNING:

Using Ultra Shield™ Plus magnet wire will ease your mind, relieve your customers' stress and keep you coming back for more.



Ultra Shield™ Plus Magnet Wire

At Essex, we think you should build an image not a reputation. That's why we're committed to providing you with the kinds of products that make your customers want to come back to you again and again. Ultra Shield Plus magnet wire insulation has been developed for greater resistance to voltage spikes. Performance test results indicate that Ultra Shield Plus is far superior to any other product on the market today.

With its modified polyester basecoat and amide-imide topcoat —

providing an insulation system with outstanding tough dielectric properties — it's been specifically designed for use in motors and generators that may be subjected to higher voltage spikes present in inverter duty applications. It actually improves voltage endurance and thermal properties while retaining superior chemical resistance to common solvents and refrigerants. Ultra Shield Plus. It fights the spikes. For more information and availability, contact your authorized Essex distributor.



FIGHTS THE SPIKES

www.superioressex.com

Essex Group, Inc. 1601 Wall Street | Fort Wayne, Indiana 46801
(219) 461-4633 | Fax: (219) 461-4690

TABLE OF CONTENTS

1 CLEANING AND STRIPPING CHEMICALS	
Solvents	4
Cold Strip	4
Contact Cleaner	4
Degreaser	4
Spray Solvent	4
2 BASE INSULATIONS	
Flexible Insulations	
NOMEX*	5
NOMEX* BOND	5
DACRON* MYLAR* DACRON*	6
RAG MYLAR* RAG	6
COPACO RAG	6
PYROMID 180	6
Rigid Insulations	
MICARTA** Sheets	
CE	7
G-10	7
GLASTIC***	
TSF	7
UTR	7
FHT	8
SG200	8
Vulcanized Fiber	7
Pressboard	7
MICARTA** Rods	
CE	8
G-10	8
MICARTA** Tubing	
LE	8
G-10	8
Tapes and Wrappers	
Mica Sheets	9
Armor Tape	9
Fiberglass Tape	9
Cotton Tape	9
VPI Mica Tapes and Wrappers	10
Fully Cured Mica Tapes and Wrappers	10
B-Staged Mica Tapes and Wrappers	10
Corona Protection Tapes	10
Heat Set Polyester Tape	10
3 COIL WINDING	
Tie Wraps	11
Polyester Shrinkable Tie Tape	11
Nylon Ty-Wraps	11
Polyester Tie Tape	11
Nylon Twist Locks	11
Coil Clips	11
Essex® Magnet Wire	12-15
4 INTERMEDIATE INSULATION	
Stick Glass Tape	16
Var-H Glass Cloth	16
NOMEX* 411	16
Separator Coils	
NOMEX*	16
DMD	16
RMR	16
Formed NOMEX* Separators	16
Wedges	
Fiber	17
DMD	17
Duroid	17
NOMEX*	18
Wood	19
Polyester	19
Topsticks	
Glass Reinforced	20
Melamine	20
5 CONNECTION INSULATION	
Sleeving & Tubing	
Acrylic	21
Silicone	21
VPI	22
Heat Shrink	22
Hermetic	22
Lead Wire	
Silicone Rubber Glass	23
Hermetic	23
HYPALON* Belden	23
Exar 600 Volt	24
HYPALON* Essex	24
EPDM 600 Volt	25
EPDM 7500 Volt	26
Exar 7500 Volt	26
HYPALON* 5000 Volt	27
XL-DUR	27
PVC	27
Solder	28
Soldering Paste	28
Soldering Salts	28
Silver Solder	28
Stator Clips	28
Phos Copper	28
Sil Phos	28
Silicone Rubber Caps	28
Terminals	29
Wire Nuts	29, 108

All sales are subject to Standard Terms and Conditions on the inside back cover of this catalog. All statements, technical information and recommendations made herein by Essex Group, Inc., seller, are based on tests we believe to be reliable, but the accuracy or completeness thereof is not guaranteed.

® Essex is a registered trademark of Essex Group, Inc.
 * Dacron, Mylar, Kevlar & Nomex are registered trademarks of E.I. DuPont de Nemours.
 ** Micarta is a registered trademark of International Paper.
 *** Glastic is a registered trademark of the Glastic Corporation.

6 SECURING THE WINDINGS

Tie Cords	
Polyester Tie Tape	30
Waxed Linen Tie Cord	30
NOMEX* Tie Tape and Cord	30
Waxed Nylon Tie Tape	30
Fiberglass	30
Blocking	
Dry Felt Blocking	31
B-Stage Blocking	31
NOMEX* Felt Blocking	31
Surge Rope	
Polyester/KEVLAR*	31
Glass	31
B-Stage	31
Banding	
RES-I-GLAS	32
Coil Band	32
RES-I-STRAINT	32
RES-I-BAND	32
HI Shrink Tape	32

7 FINAL INSULATION

Masking Compounds	33
Release Agent	33
Air Dry Varnishes	34, 36
Solventless Epoxy Varnishes	35, 36
Solventless Polyester Varnishes	35
Solventless Varnish	37
Solvent Based Varnish	38
Silicone Varnish	39
Wet Winding Compound	39
Clear Spray Varnish	39
Co-Polymer Varnishes	39-40
Thinners and Reducers	41
Tape Adhesive	41
Varnish Kits	42
Coatings	43
Paints	44-46

8 ADHESIVE TAPES

Glass	47
Glass/Film	47
Paper/Film	47
Cotton	47
Vinyl	48
Masking	48
Guide Line Tape	48
Splicing	48
Color Coding	48

9 DOW CORNING PRODUCTS

Electric Motors	
Bearing Greases	49
Noncorrosive Sealant	49
Pene-Lube	49
Antiseize Paste	49
Metal Protection Coating	49
Worm Gear Speed Reducers	
O-Ring Lubricant	50
Antiseize Paste	50
Pene-Lube	50
Metal Assembly	50
Oil Resistant Sealant	50

9 DOW CORNING PRODUCTS (continued)

Pump Applications	
Adhesive Sealant	51
Bearing Grease	51
O-Ring Lubricant	51
Valve Lubricant and Sealant	51
Antiseize Paste	51

10 PERMABOND PRODUCTS

Thread Locker	52
Permanent Retainer	52
Gasket Maker	52
Pipe Sealant	52
Adhesive (Cyanoacrylate)	52
Metal Bonding Cyanoacrylate Adhesive	52
Non Drip Cyanoacrylate Adhesive	53
Epoxy Repair	53
Structural Bonding Epoxy	53
Metal Repair	53
Anti-Seize	53

11 MISCELLANEOUS

Junction Box Sealants	54
Adhesive Sealants	54
Connection Coatings	54
Balancing Compounds	54
Dielectric Fluid	54
Sealer Paste	54
Epoxy Adhesive	55
Instant Adhesive	55
Acrylic Adhesive	55
Wire Markers	56

12 PARTS AND ACCESSORIES

Motor Cooling Fans	
Progressive Manufacturer	57-60
Progressive Blank Bore	61-62
Yellow Fan Blades	63
Rotating Mechanisms	
Syncrosnap Rotating Mechanisms	64
Progressive Listing	65-69
Flyweight Rotating Mechanisms	70
Flyweight Rotating Spools	70
Flyweight Rotating Mechanisms Springs	72

13 BEARINGS AND ACCESSORIES

Bearings	
Radial Ball Bearings	73-74
Double Row Ball Bearings	74
Angular Contact Bearings	74-75
Cartridge Bearings	75
Cylindrical Roller Bearings	76
Spherical Roller Bearings	76
Sleeve Bearings	77-81
Self Aligning Sleeve Bearings	81
Bronze Bushings	82
Bearing Accessories	
Bearing Grease	71
End Bell Repair Sleeves	71
Fiber Washers	83
Metal Washers	83
Steel Washers	83
Tolerance Rings	71
Wavy Spring Washers	83

*Kevlar & Nomex are registered trademarks of E.I. DuPont de Nemours.

14 MOTOR REPAIR ACCESSORIES

Eyebolts	.84
Flingers	.84
Nameplates	.84
Nameplate Drive Screws	.84
Silicone Rubber Space Heaters	.85
Terminal Boxes	
Steel	.85
Cast Iron	.85
Aluminum	.85

15 CAPACITORS

Start Capacitors	.86
Run Capacitors	.87-89
Dry Run Capacitors	.89
Accessories	.89

16 RELAYS & CONTROLS

Current Starting	.90-91
Sinpac	.92-93
Macrostart	.94
Speed Controls	.95
General Purpose Relays	.96-97
Definite Purpose Contactors	.98

17 THERMAL PROTECTION DEVICES

Overloads	.99
RTDs	.100
Thermistors	.101
Thermocouples	.101
Thermostats	.101

18 HAND TOOLS & SHOP SUPPLIES

3M Abrasives & Accessories	.102-103
Air Hammers	.107
Bearing Heaters	.114
Bearing Installers	.112
Bearing Puller Adapters	.113
Cable Cutter	.104
Chisels	.107
Coil Shapers	.103
Coil Tamping Pliers	.104
Coil Tamping Tools	.103-104
Commutator Cutters	.109
Commutator Resurfacers	.110
Commutator Saws	.109
Continuity Tester	.104
Cratex Abrasives	.102
Dead Blow Hammers	.106
Dereeling Equipment	.120
Grinders	.107
Kukko Hydraulic Ram & Separators	.113
Lacing Hook	.103
Lamination Tooth Straightener	.104
Mueller Clips & Insulators	.106
Rawhide Hammers	.106
Resin Spray Gun	.104
Shears	.104
Slings	.108
Slot Brushes	.104
Slot Files & Scrapers	.109
Tie Cutter	.105
Tote Pans	.108
Undercutters	.115-119

18 HAND TOOLS & SHOP SUPPLIES (continued)

Vernier Caliper	.104
Wedge Driver	.103
Wedge Remover	.104
Winding Horn	.103
Winding Paddle	.103
Wire Gauge	.104
Wire Strippers	.104-105

19 TOOL PARTS

Jacobs Chucks	.108
Terminals Wire Nuts	.29, 108

20 MOTOR PART BY MANUFACTURER

A.O. Smith/Westinghouse	.121-125
Baldor	.126
Bell & Gossett	.127-128
Bodine	.129
Century	.156-157
Dewalt	.130
Doerr	.130
Electra	.131
Emerson	.131-132
Flint & Walling	.132
Franklin	.133-135
General Electric	.136-151
Hobart	.152
Howell	.152
Iron Fireman	.153
Jack & Heintz	.152
Kingston Conley	.152
Leeson	.154
Leland Gas Pump	.155
Lima	.155
Magnetek	.156-157
Marathon	.158-159
Reliance	.160-161
Torq	.162
US Electric	.163

21 MOUNT RINGS

Progressive Listing	.164
---------------------	------

22 SHOP EQUIPMENT

Bake Ovens	.166
Balancing Machines	.165
Burn Off Ovens	.166
Coil Cut Off Machines	.167
Coil Forming Equipment	.168
Cutters & Shears	.169
Dip Tanks	.169
Dynamometers	.165
Parts Washers	.168
Pullers	.167
Sand Blasters	.167
Spray Booths	.167
Tension Devices & Dereelers	.166
Test Centers & Test Equipment	.168
V P I Systems	.169
Winding Heads	.165
Winding Machines	.165
Wire Racks	.166

23 INDEX OF SUPPLIERS

.170-171

CLEANING AND STRIPPING CHEMICALS

ELECTRON DIELECTRIC SOLVENT ENVIRONMENTALLY PREFERRED

A safe, non-toxic, high dielectric strength cleaning solvent for use in cleaning motor windings, switchgears and parts washing. Strong enough to remove grease, fuel oil, carbon and organic resins, yet safe on most plastics and rubber surfaces. Fully evaporative and leaves no residue. 46,000 Volt dielectric strength, 147°F Flash point. Contains no hazardous ingredients as defined by EPA. Great for reconditioning motors that are already wound!



DESCRIPTION	PART NUMBER
15 Oz. Aerosol	ECO-DS15
22 Oz. Pump Spray	ECO-DS22
1 Gallon	ECO-DS1G
5 Gallon	ECO-DS6G

KLEER FLO DEGREASER 99R

Now you won't have to sacrifice cleaning performance to avoid hazardous waste problems. Contains no ingredients listed as hazardous by the EPA RCRA act. Yet it cleans grease, sludge, oils and dirt quickly and efficiently. Needs no rinsing and leaves no residue. High 141°F flash point.



DESCRIPTION	PART NUMBER
5 Gallon	TKF-99R-5
30 Gallon	TKF-99R-30
55 Gallon	TKF-99R-55

ECOLINK 2005 CONTACT CLEANER

CFC-Free contact cleaner. Ecolink 2005 is designed to clean contacts, relays and other critical electronic components. Non-flammable 32,000+ volts dielectric strength. Fully evaporative, leaves absolutely no residue. Safe on most plastics, printed circuit boards and other sensitive surfaces. No flash point.



SIZE	PART NUMBER
14 Oz. Aerosol	ECO-2005

KLEER FLO HI-T DEGREASOL

Special formulation of petroleum distillates, surfactants, cleaning and wetting agents provide top performance. Needs no rinsing and leaves no residue. Safe for use on plastics, babbitt, solder and painted surfaces. Quickly cuts through grease, sludge and dirt. Meets California Rule 66 for clean air. Contains no chlorinated or aromatic solvents. 124°F flash point.



DESCRIPTION	PART NUMBER
5 GALLON	TKF-100-75
30 GALLON	TKF-100-730
55 GALLON	TKF-100-755

SUPER AQUATENE 360

Aqueous-based alkaline parts cleaning concentrate. Effectively removes oils, light grease and dust. Safe on most metals, plastics and rubber compounds. Biodegradable, contains no phosphates. Dilute with water, 4:1 for heavy cleaning 10:1 for light cleaning. A 5 gallon can will make 25-55 gallons of solution.



SIZE	PART NUMBER
5 Gallon	GM-360-C5
55 Gallon	GM-360-C55

Step # 1

Prepping The Stator

Before you start to wind the stator it must be clean and dry. A clean stator prevents oils and greases from contaminating the winding and producing a path for arcing.

Environmentally Conscious

As the government is getting tougher and tougher on hazardous chemicals in the work place we must make sure that we are using cleaning chemicals that are friendly to the environment. Most of the chemicals on this page were selected because they are considered safe for use by the EPA when used according to manufacturers instructions.

VANGUARD COLD STRIP

Specially formulated to chemically strip electric motor windings. Submerge stator completely in cold strip solution. Allow to soak for several hours to dissolve the varnish. Place 3 inches of water on top of stripper in tank to prevent evaporation.



Works on most solvent based varnishes and polyester base solventless varnishes. Safe for aluminum frame motors. This product is a known carcinogen and extra care should be taken when using this product. Have adequate ventilation.

SIZE	PART NUMBER
5 Gallon	VCS-5
30 Gallon	VCS-30
55 Gallon	VCS-55

BASE INSULATIONS - FLEXIBLE INSULATIONS

Step # 2

Insulating The Core.

Decide what temperature class insulation system you want to provide. Choose an insulation that provides the correct temperature rating. Pick a thickness that provides the most tear resistance yet leaving enough room for the winding to fit easily in the slot.



Available in SHEETS, ROLLS & CUFFS

Sheets: Handy 24" X 36" sheets are a convenient way of using flexible insulation. Sheets allow you to get only the amount of insulation you need for the job. 36" x 36" are also available. Contact your Essex Brownell representative for price and availability.

Rolls: Rolls are typically 36" wide x 36 yds long. Rolls are an economical method of purchasing flexible insulation as there is less waste involved with using rolls.

Cuffs: Cuffed coils offer the ultimate in time saving advantages when you are rewinding a number of stators with the same stack length. Precut to slot length, cuffed coils only need to be cut to width. A 3/16" cuff on the end of the slot liner helps hold it in place and adds mechanical strength to resist tearing.



NOMEX* 410

HERMETIC APPROVED CLASS R (220°C)

NOMEX* 410 is the original form of NOMEX* paper. It is a calendered product offering high dielectric strength, mechanical toughness, flexibility and resilience. Mil spec MIL-I-24204-A. UL listed.

NOMINAL THICKNESS (IN.)	DIELECTRIC STRENGTH VOLTS/MIL	TEAR RESISTANCE		SHEET 24X36 INCHES	ROLLS 36 IN. X 36 YDS
		MD1	XD1		
0.005	635	7.3#	3.6#	NX-410-005-24X36	NX-410-005-36IN
0.007	845	11#	5.6#	NX-410-007-24X36	NX-410-007-36IN
0.010	800	16#	9.2#	NX-410-010-24X36	NX-410-010-36IN
0.012	840	21#	11.4#	NX-410-012-24X36	NX-410-012-36IN
0.015	810	26#	16#	NX-410-015-24X36	NX-410-015-36IN
0.020	790	36.4#	24.1#	NX-410-020-24X36	NX-410-020-36IN
0.030	695	54.1#	43#	NX-410-030-24X36	NX-410-030-36IN

MD1 = Machine Direction XD1 = Cross Machine Direction.

Other Sheet Sizes And Slit Rolls Are Available For All Flexible Insulation. Call for Price And Availability.

NOMEX* 414

HERMETIC APPROVED CLASS R (220°C)

NOMEX* 414 is designed for applications requiring a stronger yet flexible and conformable insulation. It is electrically and thermally similar to type 410, but calendered under different conditions to provide higher tensile strength and fold endurance. Mil spec MIL-I-24204-A. UL listed.

NOMINAL THICKNESS (IN.)	DIELECTRIC STRENGTH VOLTS/MIL	TEAR RESISTANCE		SHEET 24X36 INCHES	ROLLS 36 IN. X 36 YDS	CUFFED COIL
		MD1	XD1			
0.007	710	10.8#	5#	NX-414-007-24X36	NX-414-007-36IN	
0.010	755	16#	7.7#	NX-414-010-24X36	NX-414-010-36IN	ANC-010-414-***
0.012	755	21#	9.4#	NX-414-012-24X36	NX-414-012-36IN	
0.015	740	25#	12.5#	NX-414-015-24X36	NX-414-015-36IN	ANC-015-414-***

*** INSERT THE WIDTH BETWEEN CUFF IN 1/8" INCREMENTS (i.e. ANC-010-414-8-1/2).

010 Cuffed Coils are 1500 inches long .015 Cuffed Coils are 1000 inches long

MD1 = Machine Direction XD1 = Cross Machine Direction .

Other Sheet Sizes And Slit Rolls Are Available For All Flexible Insulation. Call for Price And Availability



NOMEX* BOND

HERMETIC APPROVED CLASS H (180°C)

NOMEX* bond is a combination of type 416 NOMEX* bonded on both sides of polyester film. It takes advantage of the excellent thermal aging properties of NOMEX* for long term heat resistance, while utilizing the tear resistance of polyester film. UL listed.

NOMINAL THICKNESS (IN.)	DIELECTRIC STRENGTH VOLTS	TEAR RESISTANCE		SHEET 24X36 INCHES	ROLLS 36 IN. X 36 YDS
		MD1	XD1		
0.010	11,600	11#	10#	NB-3-3-3-24X36SH	NB-3-3-3-36IN
0.012	12,600	14#	12#	NB-3-5-3-24X36SH	NB-3-5-3-36IN
0.0135	15,000	16#	13#	NB-5-3-5-24X36SH	NB-5-3-5-36IN
0.014	16,000	16#	22#	NB-3-7.5-3-24X36SH	NB-3-7.5-3-36IN
0.0155	17,000	16#	22#	NB-5-5-5-24X36SH	NB-5-5-5-36IN
0.020	21,000	57#	47#	NB-5-10-5-24X36SH	NB-5-10-5-36IN

MD1 = Machine Direction XD1 = Cross Machine Direction .

Other Sheet Sizes And Slit Rolls Are Available For All Flexible Insulation. Call for Price And Availability.



*Nomex is a registered trademark of E.I. DuPont de Nemours.

BASE INSULATIONS - FLEXIBLE INSULATIONS

DACRON* MYLAR* DACRON* HERMETIC APPROVED CLASS F (155°C)



DMD is a combination of polyester mat on both sides of polyester film. The polyester film provides the dielectric strength while the polyester mat provides the mechanical strength. The polyester mat on both sides is fully saturated with a hermetically stable epoxy resin to impart smooth abrasion-resistant surfaces.

NOMINAL THICKNESS (IN.)	DIELECTRIC STRENGTH VOLTS/MIL	TEAR RESISTANCE		SHEET 24X36 INCHES	ROLLS 36 IN. X 36 YDS	CUFFED COILS
		MD1	XD1			
0.006	9,000	8#	5#	DM-2-2-2-SH	DM-2-2-2-RL	
0.009	8,900	12#	9#	DM-3-3-3-SH	DM-3-3-3-RL	
0.011	12,000	18#	13#	DM-3-5-3-SH	DM-3-5-3-RL	ADMD-3-5-3-***
0.014	15,000	25#	20#	DM-3-7.5-3-SH	DM-3-7.5-3-RL	
0.014	9,300	17#	11#	DM-5-3-5-SH	DM-5-3-5-RL	
0.0154	14,000	22#	15#	DM-5-5-5-SH	DM-5-5-5-RL	ADMD-5-5-5-***
0.016	19,800	25#	24#	DM-3-10-3-SH	DM-3-10-3-RL	
0.020	17,600	34#	26#	DM-5-10-5-SH	DM-5-10-5-RL	

Mil spec MIL-I-22834.
MIL-E-917D (NAVY)

*** Insert Width Between Cuffs In 1/8" Increments (I.E. ADMD-5-5-5-7-1/4)

Cuffed Coils Are 1500 Inches Long MD1 = Machine Direction XD1 = Cross Machine Direction Slit Rolls Are Available For All Flexible Insulation. Call For Price And Availability.

RAG-MYLAR*-RAG CLASS A (105°C)



Paper/polyester film composites are available in both two and three ply combinations. Two ply combinations are normally used in small units where the optimum space savings is desired. Three ply combinations are typically used in larger units where the mechanical protection of the film is important and space is not a problem.

NOMINAL THICKNESS (IN.)	DIELECTRIC STRENGTH VOLTS/MIL	TEAR RESISTANCE		SHEET 24X36 (IN.)	ROLLS 36 IN. X 36 YDS	CUFFED COILS
		MD1	XD1			
0.007	8,000	9#	7#	CM-5R-2M-SH	CM-5R-2M-36IN	ARM-52-***
0.009	9,000	10#	8#	CM-7R-2M-SH	CM-7R-2M-36IN	
0.012	9,000	14#	11#	CM-10R-2M-SH	CM-10R-2M-36IN	
0.012	9,500	15#	13#			ARMR-5-1-5-***
0.013	12,740	21#	16#	CM-5R-2M-5R-SH	CM-5R-2M-5R-36IN	
0.014	10,000	28#	14#	CM-5R-3M-5R-SH	CM-5R-3M-5R-36IN	
0.017	12,000	30#	23#	CM-7R-2M-7R-SH	CM-7R-2M-7R-36IN	
0.023	12,200	30#	23#	CM-10R-2M-10R-SH	CM-10R-2M-10R-36IN	

Mil spec MIL-I-19632.

*** Insert width between cuffs in 1/8" increments (i.e. ARMR-5-1-5-6-3/4)

Cuffed Coils are 3000 inches long MD1 = Machine Direction XD1 = Cross Machine Direction .
Other Sheet Sizes And Slit Rolls Are Available For All Flexible Insulation. Call for Price And Availability.

COPACO/RAG CLASS A (105°C)



Copaco electrical insulating papers are 100% rag stock papers expressly designed for the most exacting electrical uses. They are made from high grade "New Cotton Cuttings" highly refined to insure maximum purity and physical strength.

NOMINAL THICKNESS (IN.)	DIELECTRIC STRENGTH VOLTS/MIL	TEAR RESISTANCE		SHEET 24X36 (IN.)
		MD1	XD1	
0.005	300	180	220	CP-005-24X36-SH
0.007	300	280	380	CP-007-24X36-SH
0.010	300	550	700	CP-010-24X36-SH
0.015	300	850	1200	CP-015-24X36-SH
0.020	300	1400	1700	CP-020-24X36-SH
0.025	300	1600	2200	CP-025-24X36-SH
0.030	300	1600+	2200+	CP-030-24X36-SH

MD1 = Machine Direction XD1 = Cross Machine Direction Other Sheet Sizes And Slit Rolls Are Available For All Flexible Insulation. Call for Price And Availability.

PYROMID 180 CLASS H (180°C)



Pyromid 180 is a combination of nonwoven aramid mat on both sides of polyester film which looks and handles like DMD, but with higher temperature resistance. It is supplied 100% saturated with a fully cured, hermetically stable epoxy resin.

NOMINAL THICKNESS (IN.)	DIELECTRIC STRENGTH VOLTS/MIL	TEAR RESISTANCE		SHEET 24X36 (IN.)	ROLLS 36IN.X36YDS.
		MD1	XD1		
0.0085	10,000	6	4	P180-2-3-2-24X36	P180-2-3-2-36IN
0.0105	14,000	10	7	P180-2-5-2-24X26	P180-2-5-2-36IN
0.013	20,000	14	13	P180-2-7.5-2-24X36	P180-2-7.5-2-36IN
0.0152	21,000	19	16	P180-2-10-2-24X36	P180-2-10-2-36IN
0.019	27,000	28	28	P180-2-14-2-24X36	P180-2-14-2-36IN
0.010	10,000	10	7	P180-3-3-3-24X36	P180-3-3-3-36IN
0.012	13,000	13	10	P180-3-5-3-24X36	P180-3-5-3-36IN
0.015	18,000	20	15	P180-3-7.5-3-24X36	P180-3-7.5-3-36IN
0.017	23,000	24	21	P180-3-10-3-24X36	P180-3-10-3-36IN
0.0215	27,000	37	32	P180-3-14-3-24X36	P180-3-14-3-36IN

MD1 = Machine Direction XD1 = Cross Machine Direction Other Sheet Sizes And Slit Rolls Are Available For All Flexible Insulation. Call for Price And Availability.



*Dacron and Mylar are registered trademarks of E.I. DuPont de Nemours.

©Essex Group, Inc., 1998

BASE INSULATIONS - RIGID INSULATIONS

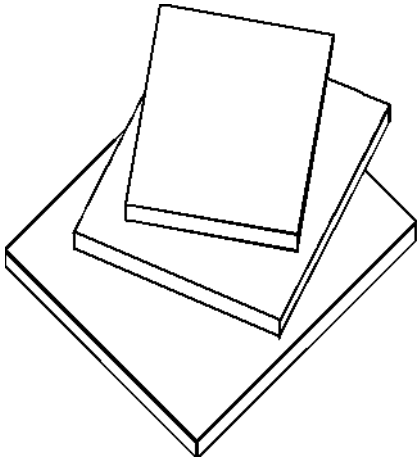

VULCANIZED FIBER CLASS A (115°C)



Commercial grade fiber. High mechanical and dielectric strength. Excellent machining characteristics. Good shock absorbing and wear resistant qualities. Flexural strength 26,000 PSI machine direction, 16,000 PSI cross direction. Sheets are 24"x36".

THICKNESS (IN.)	PART NUMBER
.010	VF-RED-010-SH
1/32	VF-RED-032-SH
1/32	VF-GRAY-032-SH
3/64	VF-GRAY-047-SH
1/16	VF-RED-062-SH
1/16	VF-GRAY-062-SH
3/32	VF-GRAY-093-SH
1/8	VF-RED-125-SH
1/8	VF-GRAY-125-SH
3/16	VF-RED-187-SH
1/4	VF-RED-250-SH
1/4	VF-GRAY-250-SH
3/8	VF-GRAY-375-SH
1/2	VF-GRAY-500-SH

PRESSBOARD CLASS A (105°C)



100% unbleached Kraft wood pulp dielectric strength 275 volts per mil. Used as transformer layer insulation and other applications where the ultimate in electrical and physical strengths are required. For use on both oil filled and dry type.

THICK (IN.)	LBS./SHEET	PART NUMBER
1/32	1.43	GP-032-28X42
1/16	2.76	GP-062-28X42
3/32	4.15	GP-093-28X42
1/8	5.52	GP-125-28X42

MICARTA* SHEETS



Laminated thermosetting products consist of fibrous reinforcing materials such as paper, cotton or glass materials, bonded with resins. Common resins used as binders are phenolic, glass or melamine. Cotton base materials with phenolic binders provide higher mechanical strength than paper base and are better suited for machining. Glass base with epoxy binder combine high mechanical strength, good electrical properties and excellent moisture resistance. Typical uses include spacers, fillers, topsticks and terminal boards etc.

CE GRADE (120°C)



Economy grade, canvas base, phenolic binder, good moisture resistance, good machining qualities. 19,000 PSI flexural strength, 600 volt dielectric. Tan color. Meets mil spec MIL-P15035-FBG, LP-509-II.

THICK (IN.)	LBS./SHEET	PART NUMBER
1/32	2	CE-032-36X36SH
1/16	4	CE-062-36X36SH
3/32	6	CE-093-36X36SH
1/8	8	CE-125-36X36SH
3/16	12	CE-187-36X36SH
1/4	16	CE-250-36X36SH
5/16	20	CE-3125-36X36SH
3/8	24	CE-375-36X36SH
7/16	28	CE-4375-36X36SH
1/2	32	CE-500-36X36SH
5/8	40.5	CE-625-36X36SH
3/4	48.6	CE-750-36X36SH

G10 GRADE (150°C)



Glass base epoxy binder. High flexural, impact & bond strength with good electrical properties. 550 VPM dielectric, 70,000 PSI flexural strength. Green color. Mil spec MIL-P18177-GEE, LP-509-IV.

THICK (IN.)	LBS./SHEET	PART NUMBER
1/32	3.8	G10-032-36X48SH
1/16	7.4	G10-062-36X48SH
3/32	11	G10-093-36X48SH
1/8	14.9	G10-125-36X48SH
3/16	22.4	G10-187-36X48SH
1/4	29.8	G10-250-36X48SH
5/16	37.3	G10-3125-36X48SH
3/8	44.7	G10-375-36X48SH
7/16	52.2	G10-4375-36X48SH
1/2	59.6	G10-500-36X48SH
5/8	74.5	G10-625-36X48SH
3/4	89.4	G10-750-36X48SH

GLASTIC*** SHEETS



GLASTIC*** laminates offer a superior combination of electrical and mechanical properties. You can punch, drill, mill, saw, shear, sand and rout all GLASTIC*** laminates. Shear thickness under 1/4", saw thickness over 1/4".

TSF GRADE CLASS F (155°C)



NEMA spec GPO-1 General purpose, high impact, heat resistant. 22,300 PSI flexural strength. Tan color. Mil spec MIL-LP-509/GPO-1.

THICKNESS (IN.)	PART NUMBER
1/32	TSF-1/32-36X36
1/16	TSF-1/16-36X36
3/32	TSF-3/32-36X36
1/8	TSF-1/8-36X36
3/16	TSF-3/16-36X36
1/4	TSF-1/4-36X36
3/8	TSF-3/8-36X36
1/2	TSF-1/2-36X36

UTR GRADE CLASS F (155°C)



NEMA spec GPO-3, Track resistant, flame resistant. For use on 2500+ voltage equipment. 94V-O flame retardance rating. 22,100 PSI flexural strength. Red color. UL File E81928.

THICKNESS (IN.)	PART NUMBER
1/32	UTR-1/32-36X36
1/16	UTR-1/16-36X36
3/32	UTR-3/32-36X36
1/8	UTR-1/8-36X36
3/16	UTR-3/16-36X36
1/4	UTR-1/4-36X36
3/8	UTR-3/8-36X36
1/2	UTR-1/2-36X36

Other Sheet Sizes & Grades Available on Request. Call For More Information.

** Micarta is a registered trademark of International Paper.
 *** Glastic is a registered trademark of the Glastic Corporation.



BASE INSULATIONS - RIGID INSULATIONS

SG200 GRADE CLASS H (210°C)



NEMA Grade GPO-1. No other material on the market has such high heat properties at a price 1/3 that of silicone. Widely used in motors and dry type transformers. 29,000 PSI flexural strength. UL file E81928.

THICKNESS (IN.)	PART NUMBER
1/32	SG200-1/32-36X36
1/16	SG200-1/16-36X36
3/32	SG200-3/32-36X36
1/8	SG200-1/8-36X36
3/16	SG200-3/16-36X36
1/4	SG200-1/4-36X36
3/8	SG200-3/8-36X36
1/2	SG200-1/2-36X36
5/8	SG200-5/8-36X36
3/4	SG200-3/4-36X36

FHT GRADE CLASS H (190°/200°C)

Strong and highly flexible material with excellent dielectric strength. It's high heat resistance makes it a very cost effective product for use in dry type transformers, and as a spacer in motor applications. 450 volt per mil dielectric strength. Cream color.

THICKNESS (IN.)	PART NUMBER
1/32	FHT-1/32-36X36
1/32	FHT-1/32-36X72
1/16	FHT-1/16-36X36
1/16	FHT-1/16-36X72
1/8	FHT-1/8-64X64
3/16	FHT-3/16-64X64

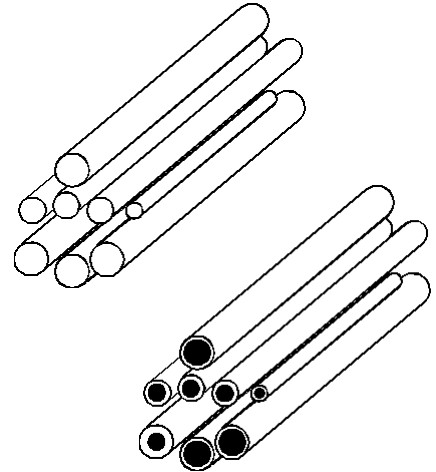

MICARTA** RODS

See previous page for information and specs for MICARTA** rods.



CE GRADE (120°C)

SIZE	PART NUMBER
1/4" X 3FT	CE-1/4X3FT
3/8" X 3FT	CE-3/8X3FT
1/2" X 3FT	CE-1/2X3FT
5/8" X 3FT	CE-5/8X3FT
3/4" X 3 FT	CE-3/4X3FT
7/8" X 3FT	CE-7/8X3FT
1" X 3FT	CE-1INX3FT
1-1/8" X 3FT	CE-1-1/8X3FT
1-1/4" X 3FT	CE-1-1/4X3FT

G10 GRADE (150°C)

SIZE	PART NUMBER
1/4" X 3FT	G10-1/4X3FT
3/8" X 3FT	G10-3/8X3FT
1/2" X 3FT	G10-1/2X3FT
5/8" X 3FT	G10-5/8X3FT
3/4" X 3 FT	G10-3/4X3FT
7/8" X 3FT	G10-7/8X3FT
1" X 3FT	G10-1INX3FT
1-1/8" X 3FT	G10-1-1/8X3FT
1-1/4" X 3FT	G10-1-1/4X3FT

MICARTA** TUBING

Tubes are produced by rolling impregnated base material on mandrels between heated rollers. The resins are then cured to produce a virtually infusible and insoluble product. Can be easily machined. 3 foot lengths.



LE GRADE (120°C)

Economy grade with good electrical characteristics, 600 volt dielectric, and good moisture resistance. Tan color. Mil spec MIL-P-15035-FBE.

SIZE (IN.)	PART NUMBER
1/4 X 3/8	LE-1/4X3/8X3FT
1/4 X 1/2	LE-1/4X1/2X3FT
3/8 X 1/2	LE-3/8X1/2X3FT
3/8 X 5/8	LE-3/8X5/8X3FT
1/2 X 5/8	LE-1/2X5/8X3FT
1/2 X 3/4	LE-1/2X3/4X3FT
5/8 X 3/4	LE-5/8X3/4X3FT
5/8 X 7/8	LE-5/8X7/8X3FT
3/4 X 7/8	LE-3/4X7/8X3FT
3/4 X 1	LE-3/4X1X3FT
7/8 X 1	LE-7/8X1X3FT
7/8 X 1-1/8	LE-7/8X1-1/8X3FT

G10 GRADE (150°C)

Glass base melamine binder. High flexural impact & bond strength with good electrical properties. 550 VPM dielectric, 70,000 PSI flexural strength. Green color. Mil spec MIL-P-18177-GEE.

SIZE (IN.)	PART NUMBER
1/4 X 3/8	G10-1/4X3/8X3FT
1/4 X 1/2"	G10-1/4X1/2X3FT
3/8 X 1/2	G10-3/8X1/2X3FT
3/8 X 5/8	G10-3/8X5/8X3FT
1/2 X 5/8	G10-1/2X5/8X3FT
1/2 X 3/4	G10-1/2X3/4X3FT
5/8 X 3/4	G10-5/8X3/4X3FT
5/8 X 7/8	G10-5/8X7/8X3FT
3/4 X 7/8	G10-3/4X7/8X3FT
3/4 X 1	G10-3/4X1X3FT
7/8 X 1	G10-7/8X1X3FT
7/8 X 1-1/8	G10-7/8X1-1/8X3FT
1" X 1-1/8	G10-1X1-1/8X3FT

FABRICATION TIPS FOR MICARTA** INSULATIONS

When operating any piece of power equipment safety precautions should be observed. Remember to wear a mask and goggles.

SAWING

MICARTA** insulations can be cut with a circular saw. 12" diameter blades should be used on thickness up to 1" and 16" diameter up to 2-1/2" thick. Hollow ground blades produce the best cut. Material should be fed as fast as possible to prevent heating and burning.

TURNING

High speed steel can be used but carbide tipped tools offer longer tool life. High speed steel tools should be run at approximately 400 feet per minute, while carbide tipped tools can be run twice as fast.

DRILLING

Drills should be backed off frequently to prevent heating. Feed with light and uniform pressure. The material should be backed with MICARTA** to prevent chipping. Drill bit speeds should be consistent to soft steel speeds.

BASE INSULATIONS - TAPES & WRAPPERS



TYPICAL FORM COIL CONSTRUCTION Low-Medium Voltage Slot Section

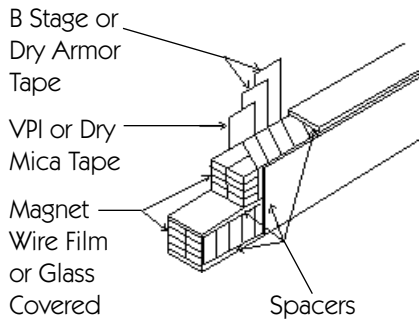

High Voltage Slot Section

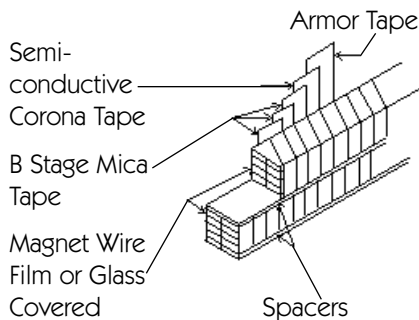

RES-I-FLEX ARMOR TAPE **FIBERTEK** CLASS F (155°C)

B-staged, epoxy coated, woven polyester/glass tape which shrinks and fuses during the cure cycle. Forms a tough conformal moisture and chemical-resistant dielectric seal around AC and DC form coils. Two half-lapped layers should insure a complete seal. 65% resin content. 2100 VPM dielectric. Tensile strength 40 LBS/in. Cure time 1 hour at 170°C or 3 hours at 150°C.

WIDTH X LENGTH	PART NUMBER
3/4" X 36 YDS	FRF-075
1" X 36 YDS	FRF-100

Custom Lengths And Widths Available.
Contact Your Essex Brownell Sales Professional.

Mica Paper & Mica Splittings Sheets SEGMENT CLASS F (155°C)

Muscovite Mica designed for motor segment applications. Rigid material can be punched, drilled or sheared without flaking or cracking. Excellent mechanical and electrical strength. 7-10 % epoxy resin binder content, 750 volt/mil dielectric strength. Thicknesses up to 1/16" are available. 36"X 36" Sheets.

THICK (IN.)	PART NUMBER
.015	42801568000
.020	42802068000
.025	42802568000
.030	42803068000
.032	42803268000
.035	42803568000
.040	42804068000

MOLDING CLASS F (155°C)

Muscovite mica paper designed for hot molding and forming applications such as tubes, channels, angles, rings, etc. 14- 20% epoxy resin content, B-staged. Once formed and cured, plate will hold shape. 850 volts/mil dielectric strength. Thicknesses up to 1/16" are available. 36"X36" sheets.

THICK (IN.)	PART NUMBER
.015	40601568000
.020	40602068000
.025	40602568000
.030	40603068000
.040	40604068000

MICA-FIBERGLASS NEMA NO. 301

Bonded layers of mica splittings between layers of .003" thick fiberglass. Fiberglass cloth adds mechanical strength and impregnated with organic varnish to add dielectric strength. Sheet size is 36"x36" inches.

THICK (IN.)	PART NUMBER
.010	MFG-1-010
.012	MFG-1-012
.015	MFG-1-015
.020	MFG-1-020
.025	MFG-1-025
.030	MFG-1-030

Other mica sheets are available. Contact your Essex Brownell Sales Professional.

FIBERGLASS TAPE

Use as a protective covering after mica tape has been applied to form coils, or as a protective covering for any coils. Available in three types. Raw glass with no coating, is the least expensive.

Clear treated, a clear sizing has been applied to resist fraying, and reinforces the tape to withstand abrasion. G10E finish, this tape has been heat treated to remove oils and starch. The heat also sets the weave to resist abrasion and fraying when cut. The G10E tape has a distinct golden color. 36 yard rolls. Part number shown is for untreated glass tape. Add -CT to part number for clear treated. Add -G10E to part number for golden finish.

M I N C .

THICK (IN.)	WIDTH (IN.)	HESGON PART NUMBER	MUTUAL PART NUMBER
.005	1/2	HGTA-005-1/2	C150-005-1/2
.005	3/4	HGTA-005-3/4	C150-005-3/4
.005	1	HGTA-005-1	C150-005-1
.005	1-1/2	HGTA-005-1-1/2	C150-005-1-1/2
.007	1/2	HGTA-007-1/2	C150-007-1/2
.007	3/4	HGTA-007-3/4	C150-007-3/4
.007	1	HGTA-007-1	C150-007-1
.007	1-1/2	HGTA-007-1-1/2	C150-007-1-1/2
.010	1/2	HGTA-010-1/2	C150-010-1/2
.010	3/4	HGTA-010-3/4	C150-010-3/4
.010	1	HGTA-010-1	C150-010-1
.010	1-1/2	HGTA-010-1-1/2	C150-010-1-1/2
.015	1/2	HGTA-015-1/2	C150-015-1/2
.015	3/4	HGTA-015-3/4	C150-015-3/4
.015	1	HGTA-015-1	C150-015-1
.015	1-1/2	HGTA-015-1-1/2	C150-015-1-1/2

HESGON



COTTON TAPE CLASS A (105°C)

An economical wrapping tape for use as an armature or field coil wrapper, also used on transformer windings and field coils supports.

Some of the unique characteristics of Narroline cotton tapes are they are non-curling, non-kinking, and non-twisting. They exhibit uniform thickness and width and possess maximum varnish absorption characteristics. Standard length is 36 yards.



TAPE WIDTH (IN.)	.005 THICK	.007 THICK	.007 LW THICK	.015 THICK	.020 THICK	.030 THICK
1/4	A-1-005-1/4	A-2-007-1/4	A-3-007-1/4	B-1-015-1/4	N/A	N/A
3/8	A-1-005-3/8	A-2-007-3/8	A-3-007-3/8	B-1-015-3/8	B-2-020-3/8	N/A
1/2	A-1-005-1/2	A-2-007-1/2	A-3-007-1/2	B-1-015-1/2	B-2-020-1/2	C-1-030-1/2
5/8	A-1-005-5/8	A-2-007-5/8	A-3-007-5/8	B-1-015-5/8	B-2-020-5/8	C-1-030-5/8
3/4	A-1-005-3/4	A-2-007-3/4	A-3-007-3/4	B-1-015-3/4	B-2-020-3/4	C-1-030-3/4
1	A-1-005-1	A-2-007-1	A-3-007-1	B-1-015-1	B-2-020-1	C-1-030-1
1-1/4	A-1-005-1-1/4	A-2-007-1-1/4	A-3-007-1-1/4	B-1-015-1-1/4	B-2-020-1-1/4	C-1-030-1-1/4
1-1/2	A-1-005-1-1/2	A-2-007-1-1/2	A-3-007-1-1/2	B-1-015-1-1/2	B-2-020-1-1/2	C-1-030-1-1/2
2	N/A	N/A	A-3-007-2	B-1-015-2	B-2-020-2	C-1-030-2

LW is a special light weave version. Add -RL to the part number to order red center line tape.

BASE INSULATIONS - MICA & SEMI-CONDUCTIVE TAPES

MICA TAPES

There are basically three types of mica tapes used on form wound coils. All tapes are suitable for use with high speed taping machines or hand taping.

1) VPI style- A combination of mica paper, glass fabric and porous polyester mat with minimal resin used as a binder to maximize resin absorption during VPI treatment, and give mechanical protection during application.

2) Fully Cured- Film face on both sides of mica paper with or without glass cloth suitable for dip & bake application.

3) B-stage- Utilizes a combination of mica paper and glass cloth impregnated with a B-staged resin to form a rigid coil, typically used in hot press prior to application.



VPI MICA TAPES & WRAPPERS CLASS F (155°C)



Porous mica paper/glass fabric/polyester fleece. Bonded with minimal amount of binder for high resin absorption in VPI systems. Typical applications include ground insulation for form wound coils operating at low to high voltages. Insulation for pole and interpoles on traction motors.

OVERALL THICK. (IN.)	MICA PAPER THICK.	% RESIN CONTENT	WIDTH (IN.)	PART NUMBER
.0075	.004	14-16	3/4	4371070075036*
.0075	.004	14-16	1	4371070100036*
.0075	.004	14-16	36	4371073600050D
.0075	.003	16-18	3/4	4373200075036*
.0075	.003	16-18	1	4373200100036*
.0075	.003	16-18	36	4373203600050D
.008	.004	16-18	3/4	4378200075036*
.008	.004	16-18	1	4378200100036*
.008	.004	16-18	36	4378203600050D

*Insert Core Code A= 3/8", B= 1", C=1-1/2", D=3"

FULLY CURED MICA TAPES & WRAPPERS



Film face tape is a combination of polyester film on both sides of mica paper/glass cloth. Designed for use in dip and bake applications. Suitable for use as ground insulation on low to medium voltages. Silicone binders are suitable for Class H (180°C). Polyester and epoxy modified polyester binders are suitable for Class F (155°C).

OVERALL THICK. (IN.)	MICA PAPER THICK.	% RESIN CONTENT	RESID TYPE	PART NUMBER
.005	.0018	22	Silicone	435105*
.0055	.002	24	Epoxy Mod. Polyester	11903*
.006	.002	22	Polyester	64213*
.006	.0025	24	Epoxy Mod. Polyester	11969*
.0065	.0025	22	Polyester	64217*
.007	.004	21	Silicone	435107*
.0075	.004	22	Polyester	64206*
.008	.005	18	Polyester	64300*

* Insert width (standard widths are 3/4", 1" and 36") length, and core size A= 3/8", B= 1", C=1-1/2", D=3" Ex: 6420600075036C Special widths and lengths are available.

B-STAGED TAPES & WRAPPERS CLASS F (155°C)



4800 series utilizes Mica paper/glass fabric impregnated with an epoxy B-staged resin. Designed for use where coils are wrapped and cured before (hot press applications) or after installation with no additional varnish treatment. Suitable for use as ground insulation on medium to high voltages. 12102 & 12104 are especially well suited for use on end turns where flexibility is desired after cure. B-stage flexible polybutadiene tape remains flexible after cure, utilizes film face on both sides of mica paper and glass cloth combination, for use in all types of systems - dip & bake and VPI. Standard core size for tapes is 1-1/2"-3" is standard for wrapper rolls. Tape rolls are 36 yards long, wrapper rolls are 50 yards long. Special roll lengths are available.

OVERALL THICK. (IN.)	MICA PAPER THICK.	% RESIN CONTENT	WIDTH (IN.)	PART NUMBER
.007	.003	42	3/4	4800700075036*
.007	.003	42	1	4800700100036*
.007	.003	42	36	4800703600050D
.0055	.0025	20	3/4	1210200075036*
.0055	.0025	20	1	1210200100036*
.007	.004	20	3/4	1210400075036*
.007	.004	20	1	1210400100036*

*Insert Core Code A=3/8", B=1", C=1-1/2", D=3"

CORONA PROTECTION TAPES



It is generally an accepted practice to add some form of corona protection to coils that will be operating above 6.9 KV. Made of a polyester mat impregnated with conductive particles such as carbon. Resistance value is approximately 400-1000 ohms per square. Specially designed for use in the slot area of form wound coils. 06ELR14AA or variations of this tape may be used for press cured applications. 06ELR14VPI may be used in VPI applications.

STYLE	THICK (IN.)	PART NUMBER
Fully Cured	.004	06ELR14AA-*
VPI	.004	06ELR14VPI-*

* Insert width (standard widths are 3/4", 1" and 36". Special widths and lengths are available.)

HEAT SET POLYESTER TAPE CLASS F (155°C)



Heat shrinkable, woven polyester tape for use as service wrap or armor wrap for form wound coils. Hot knife slit edges reduces fraying. Woven for greater yarn stability and conformability. Shrinkage is approximately, 12% at 350°F for 30 min. Perfect for use in VPI systems. Thickness is .0045" and breaking strength is approximately 80 lbs. per inch of width. Packaged on 3/8" cores, other widths available.

36 YARD ROLLS	
WIDTH (IN.)	PART NUMBER
1/2	PEI126-1/2-36VD
3/4	PEI346-3/4-36VD
1	PEI1006-1-36VD
1-1/2	PEI1126-1-1/2-36VD
72 YARD ROLLS	
1/2	PEI122-1/2-72VD
3/4	PEI342-3/4-72VD
1	PEI1002-1-72VD
1-1/2	PEI1122-1-1/2-72VD



COIL WINDING - COIL TIES

Step # 3

When winding the coils, each coil needs to be bundled as it is transferred off the form over to be inserted. The tie is removed and discarded or used again. Some shops leave the ties in place after the coils have been inserted. Make sure the tie will not affect the performance of the motor.

See page 30 for more tie cords & tie tapes. We offer Glass, Nomex*, Polyester, Nylon, Linen and more!

HANSCOM TIE WRAPS

Available with a paper or a plastic cover, single or a double wire. Paper ties provide economical means of tying the coils as they are being wound. Plastic ties are designed for repeat use. Double wires provide the maximum strength. Color coded for identifying the sets of coils for insertion. Standard feet per spool is 1500. All ties are 1/4" wide.



PRE-CUT TIES

Any of the Hanscom ties can be ordered pre-cut to length. If you cut your ties to 3" lengths, why not order them pre-cut and save time? Ask us for a quote on your specifications. Dispensing Equipment Available - Ask Your Essex Brownell Representative.

MATERIAL TYPE COLOR	PLASTIC SINGLE	PLASTIC DOUBLE	PAPER SINGLE	PAPER DOUBLE
BLUE	THT-9018-BLU	THT-9088-BLU	THT-5018-BLU	THT-5088-BLU
WHITE	THT-9018-WHT	THT-9088-WHT	THT-5018-WHT	THT-5088-WHT
RED	THT-9018-RED	THT-9018-RED	THT-5018-RED	THT-5088-RED

POLYESTER SHRINKABLE TIE TAPE



Designed primarily for binding and other tying applications. Narrowline tie tapes are available in colored tape constructions and colored tracer threads for identification purposes. These tapes are flame-resistant, fungus-resistant, and fray-resistant. They offer uniform color and uniform tensile strength. Knots stay tied and resist shock, vibrations or handling.

PART NUMBER	THICKNESS (IN.)	WIDTH	MIN. BREAK
CNF-K615P	.015	1/16	35
CNF-K2515P	.015	1/4	65
CNF-K2530P	.030	1/4	210
CNF-K5030P	.030	1/2	360
CNF-K5050P	.050	1/2	360

POLYESTER TIE TAPE

Economical 100% polyester tie tape. Great for tying coils as they come off the winding heads. Cut off or leave in place during coil insertion. 1/4" wide x 1,000 yards long. 22-23 lbs. breaking strength.



PART NUMBER	PTT 1/4
-------------	---------

PREMIUM QUALITY TY-WRAPS



General purpose nylon ties hold your coils securely during the winding process. Lightweight, high strength, flame-retardant. UL flame rating 94V-2. Mil spec MIL-M-20693A, operates at temperatures from -40°C to 85°C. 100 per package.



STRENGTH	MAX. BUNDLE DIA. (IN.)	LENGTH (IN.)	WIDTH (IN.)	PART NUMBER
18 LBS	8	3-3/8	.08	T-18S
18 LBS	3/4	4	.10	T-18R
18 LBS	1-1/4	5-3/4	.10	T-18I
18 LBS	2	8	.10	T-18L
30 LBS	1-1/4	6	.14	T-30R
30 LBS	2	8	.15	T-30M
30 LBS	3	11-1/4	.15	T-30I
30 LBS	4	14-1/2	.15	T-30L
50 LBS	1-1/4	6-1/2	.18	T-50S
50 LBS	1-3/4	8	.18	T-50R
50 LBS	3	11-3/4	.18	T-50I
50 LBS	4	15-1/2	.18	T-50L

Other Types, Styles, Lengths And Colors Are Available By Special Order.

NYLON TWIST LOCKS

A revolutionary way to hold the coils during the winding process. Rounded edges prevent abrasion. A twist of the fingers locks them on. Another twist releases them! Nylon twist locks have a tensile strength of 20 lbs. and are reusable. Packed 100/box.



WIRE BUNDLE	
RANGE (IN.)	PART NUMBER
.20-.30	TWT-2
.30-.40	TWT-3
.40-.50	TWT-4
.55-.65	TWT-7

COIL CLIPS

As the coils come off the winding heads, these clips attach quickly and remove easily during coil insertion. Inexpensive and reusable.

PART NUMBER	TSC-141
-------------	---------

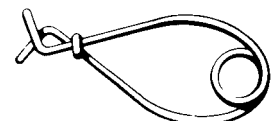

*Nomex is a registered trademark of E.I. DuPont de Nemours.

COIL WINDING - MAGNET WIRE

SPECIFYING MAGNET WIRE

1.) Select Your Insulation Type.

Use film for general purpose applications, use dacron glass covered for abrasion resistance. See page 14 for more information.

2.) Choose Your Wire Size.

Essex Brownell has round and shaped sizes available. We also have 1/2 sizes available. See page 13 for helpful hints.

3.) Pick Your Packaging.

Determine what packages are available for the wire size you need, and choose the one that best serves your requirements.



ENAMEL FILM INSULATIONS STANDARDS CHART Heavy Build Round Wire

AWG	NOMINAL	O.D.	CIRCULAR MILS	SQUARE MILS	WEIGHT LBS/MFT	RESISTANCE OHMS/MFT @ 20°C
	O.D. BARE	HEAVY BUILD				
7	.1443	.1477	20822	16350	63.56	.4981
8	.1285	.1319	16512	12970	50.45	.6281
9	.1144	.1177	13087	10280	40.01	.7924
10	.1019	.1051	10384	8155	31.77	.9988
11	.0907	.0938	8226	6461	25.19	1.261
12	.0808	.0838	6529	5128	20.01	1.589
13	.0720	.0749	5184	4072	15.91	2.001
13-1/2	.0679	.0708	4610	3621	14.16	2.249
14	.0641	.0675	4109	3227	12.65	2.524
14-1/2	.0605	.0639	3660	2875	11.28	2.833
15	.0571	.0602	3260	2561	10.05	3.181
15-1/2	.0539	.0570	2905	2282	8.968	3.570
16	.0508	.0539	2581	2027	7.966	4.019
16-1/2	.0480	.0511	2304	1810	7.12	4.501
17	.0453	.0482	2052	1612	6.343	5.054
17-1/2	.0427	.0456	1823	1432	5.643	5.688
18	.0403	.0431	1624	1276	5.028	6.386
18-1/2	.0380	.0408	1444	1134	4.477	7.182

AWG	NOMINAL	O.D.	CIRCULAR MILS	SQUARE MILS	WEIGHT LBS/MFT	RESISTANCE OHMS/MFT @ 20°C
	O.D. BARE	HEAVY BUILD				
19	.0359	.0386	1289	1012	3.960	8.047
19-1/2	.0339	.0366	1149	902.6	3.568	9.024
20	.0320	.0346	1024	804.2	3.180	10.13
20-1/2	.0302	.0328	912.0	716.3	2.837	11.37
21	.0285	.0309	812.3	637.9	2.526	12.77
21-1/2	.0269	.0293	723.6	568.3	2.254	14.33
22	.0253	.0276	640.1	502.7	1.996	16.20
22-1/2	.0239	.0262	571.2	448.6	1.784	18.16
23	.0226	.0249	510.8	401.2	1.596	20.31
23-1/2	.0213	.0236	453.7	356.3	1.420	22.86
24	.0201	.0223	404.0	317.3	1.266	25.67
24-1/2	.0190	.0212	361.0	283.5	1.133	28.73
25	.0179	.0199	320.4	251.7	1.005	32.37
26	.0159	.0178	252.8	198.6	.7954	41.02
27	.0142	.0161	201.6	158.4	.636	51.43
28	.0126	.0144	158.8	124.7	.5029	65.33
29	.0113	.0130	127.7	100.3	.4005	81.22
30	.0100	.0119	100.0	78.54	.3027	103.7

Square Wire

AWG	BARE WORE	OVERALL DIMENSION	CIRCULAR MILS	SQUARE MILS	WEIGHT LBS./MFT	RESISTANCE OHMS/MFT @ 20°C
	DIMENSION	HEAVY				
4	.204X.204	.211X.211	52570	40370	155.6	.2018
5	.182X.182	.189X.189	41370	31710	122.2	.2568
6	.162X.162	.169X.169	33800	25360	97.76	.3211
7	.144X.144	.151X.151	26750	19940	76.86	.4084
8	.129X.129	.135X.135	21120	15630	60.25	.5210
9	.114X.114	.121X.121	17430	12510	48.2	.6513
10	.102X.102	.108X.108	13880	9803	37.78	.8309
11	.091X.091	.097X.097	11000	7883	30.38	1.033
12	.081X.081	.087X.087	8790	6185	23.84	1.317

COIL WINDING - MAGNET WIRE

Question?

When is the wrong size the right size? (Getting the most from your existing wire inventory.)

1) YOU CAN SWAP SPEC/STANDARDS

There are two standards in the industry when it comes to shaped wire, Brown/Sharpe and the decimal system. The Brown/Sharpe standard uses sizes like .057, .064, .072, .081, .091, .102, etc. The decimal system uses sizes like .055, .060, .065, .070, .075, .080, .085, .090, etc. The design of most windings has enough safety built into the design that a small change in the size will not effect the performance of the motor dramatically. So changing from a decimal size of .055 to a B/S size of .057 should be feasible. When making a change of this nature you must check to make sure that it will not effect the performance of the motor. For example, a coil with just a few turns will not be effected as much as a coil with a large number of turns. Considerations of physical size must also be taken into account to make sure that there is enough space available for the change.

2) USE CONDUCTORS IN PARALLEL, WITHOUT REDUCING PERFORMANCE

Another option available is to use two or more conductors in parallel. For example, if you have a winding that is wound with .114 X .289 you might be able to use 2 - .057 X .289 or 4 - .057 X .144. Remember that as you use more conductors in parallel, you will be adding two insulation layers and consideration must be given if the space will allow such a change.



STANDARD SHAPED WIRE SIZES

.051 X .091	.057 X .162	.072 X .102	.081 X .325	.102 X .204	.128 X .182	.162 X .289
.051 X .102	.057 X .182	.072 X .114	.081 X .365	.102 X .229	.128 X .204	.162 X .325
.051 X .114	.057 X .204	.072 X .128	.081 X .408	.102 X .258	.128 X .229	.162 X .365
.051 X .128	.057 X .229	.072 X .144		.102 X .289	.128 X .258	.162 X .408
.051 X .144	.057 X .258	.072 X .162	.091 X .102	.102 X .325	.128 X .289	.162 X .458
.051 X .162	.057 X .289	.072 X .182	.091 X .114	.102 X .365	.128 X .325	
.051 X .182	.057 X .325	.072 X .204	.091 X .128	.102 X .408	.128 X .365	.182 X .229
.051 X .204	.057 X .365	.072 X .229	.091 X .144	.102 X .458	.128 X .408	.182 X .258
.051 X .229	.057 X .408	.072 X .258	.091 X .162		.128 X .458	.182 X .289
.051 X .258		.072 X .289	.091 X .182	.114 X .128		.182 X .325
.051 X .289	.064 X .091	.072 X .325	.091 X .204	.114 X .144	.144 X .162	.182 X .365
.051 X .325	.064 X .102	.072 X .365	.091 X .229	.114 X .162	.144 X .182	.182 X .408
.051 X .365	.064 X .114	.072 X .408	.091 X .258	.114 X .182	.144 X .204	
.051 X .408	.064 X .128		.091 X .289	.114 X .204	.144 X .229	.204 X .258
	.064 X .144	.081 X .102	.091 X .325	.114 X .229	.144 X .258	.204 X .289
	.064 X .162	.081 X .114	.091 X .365	.114 X .258	.144 X .289	.204 X .325
	.064 X .182	.081 X .128	.091 X .408	.114 X .289	.144 X .325	.204 X .365
	.064 X .204	.081 X .144	.091 X .458	.114 X .325	.144 X .365	
	.064 X .229	.081 X .162		.114 X .365	.144 X .408	.229 X .289
.057 X .091	.064 X .258	.081 X .182	.102 X .114	.114 X .410	.144 X .458	.229 X .325
.057 X .102	.064 X .289	.081 X .204	.102 X .128	.114 X .460		
.057 X .114	.064 X .325	.081 X .229	.102 X .144		.162 X .204	
.057 X .128	.064 X .365	.081 X .258	.102 X .162	.128 X .144	.162 X .229	
.057 X .144	.064 X .408	.081 X .289	.102 X .182	.128 X .162	.162 X .258	

COIL WINDING - MAGNET WIRE

PRODUCT DESCRIPTION	THERMAL RATING	ALCATEL	ESSEX BROWNELL	PHELPS DODGE	REA
Inverter Duty Aromatic Polyimide	200°C 220°C		US Plus Allex®	T2QS HML	Pulse S HML
Polyester/ Amide-Imide	200°C	HAMT H200 HACA	GP/MR 200®	HAPTZ HMR	HTAI HTAIH
Formvar	105°C	HF	HF	HF	HF
DACRON*/Glass W/Varnish	155°C	DVD	DDG DG2V	DDV	DDG



INSULATION TYPES

FILM INSULATION



ULTRA SHIELD™ PLUS (CODE = 77) INVERTER DUTY CLASS H (200°C)

Ultra Shield Plus is a modified polyester with amide imide overcoat, a heavy build film specially suited for use in motors where transient voltage spikes and corona are present. Has excellent abrasion and burnout resistance. Available in round wire sizes. Refer your shaped requirements to magnet wire marketing. Meets NEMA SPEC MW-73, MW-35C AND MW-73C.

GP/MR-200® (CODE = 52) HERMETIC APPROVED CLASS H (200°C)

GP/MR-200 is a modified polyester with amide imide overcoat, a heavy build film specially suited for use in motors, dry transformers and welding transformers. Available in round and shaped wire sizes. Meets NEMA SPEC MW-73, MW-35, AND MW-36, Federal spec JW-1177/13B and JW-1177-14B.

FORMVAR (CODE = 20) CLASS A (105°C)

Polyvinyl acetal coating. One of the first film insulations on the market, it is particularly suited for use in dry and oil-filled transformers. Available in round and shaped wire sizes. Meets NEMA spec MW-15C & MW-18C. Meets FED spec JW-1177/4B & JW-1177/16B.

ALEX® (CODE = 60) HERMETIC APPROVED CLASS R (220°C)

Aromatic polyimide film. The ultra high temperature rating and chemical resistance makes this the wire to use in extreme conditions. Available in round and shaped wire sizes. It is used in heavy duty hand tools, motors, high temperature continuous duty coils, hermetic and sealed units. Meets NEMA spec MW-16C, MW-20C and MW-71C, Federal spec JW-1177/15B and JW-1177/18B.

DACRON* GLASS COVERED

DACRON* GLASS FIBER OVER BARE COPPER CLASS F (155°C)

A double wrap of DACRON*/glass fibers over a bare conductor. Heated to fuse the DACRON* fibers to the glass fibers and the conductor. A coating of varnish impregnates the fibers and produces a smooth outer surface. DACRON* glass wire is used extensively in applications where high temperatures, vibrations, severe winding conditions and moisture is present. Available in round and shaped wire sizes. Meets NEMA spec MW-46C. Federal spec JW 1177/A25.

DACRON* GLASS FIBER OVER FILM CLASS F (155°C)

A double wrap of DACRON* glass fibers over a film covered conductor. The advantage of this type of system is the DACRON* glass fibers provide resistance against abrasion and the underlying film provides additional dielectric strength. Available in round and shaped wire sizes.

ESSEX also offers paper, NOMEX*, KAPTON*, and mica served wire. Check out the express service for short runs and emergency wire needs, Above specifications are for heavy build wire. Essex Brownell also offers single build, triple build, and several other types of enamels. All federal specifications for magnet wire JW-1177 have been discontinued and replaced by the appropriate NEMA MW 1000. specifications.

COIL WINDING - MAGNET WIRE

BUILDING A PART NUMBER

CONDUCTOR	BUILD	FILM	COVERING	SIZE	PACKAGE	WIRE CLASS
A=Aluminum C=Copper	1=Single 2=Heavy 3=Triple 4=Quad	20=Formvar 32=Soderex®/130 33=Soderon®/130 37=Soderex®/155 38=Soderon®/155 52=GP/MR 200® 60=Allex® 77= Ultra Shield™ Plus	1=A-Z Glass 2=A-Z Glass 3=A-Z Dac Glass 4=A-G Mica 4=N-Z Apical 6=A-M Kapton* 6=N-Z Nomex* 7=A-Z Paper XX= No Fabric	Round Size 16 is 001600 Square Size 8 is 006080 Rectangular 050x250 is 050250	06=6x6 Spool 12=12" Reel 13=Pail Pak 21=Taper Pak 24=24" Reel 81=TF 80 Reel	A=Sx Standard

6 INCH SPOOLS

6" Spools are 6" in diameter and 3-1/2" wide. They each hold about 8 lbs. of wire and come 6 to a case.
CODE - (-06)



12 INCH REELS

12" Spools are 12" in diameter and 7 inches wide. They hold approx. 85 lbs. of wire.
CODE - (-12)



24 INCH REELS

24" reels are 24" in diameter and 6 inches wide. They hold approx. 250 lbs. of wire.
CODE - (-24)



TAPER PAILS

Taper buckets are approx. 12.5 inches high and hold approx. 75 lbs. of wire. Each bucket has a spool inside upon which the wire is wound on to prevent tangling.
CODE - (-13)



INTERMEDIATE INSULATION - PHASE/SEPARATORS

STICK GLASS TAPE CLASS H (180°C)



Same great material as our VAR-H cloth but with a thermosetting acrylic adhesive applied to one side. Cut in the tape rolls for ease in use. Excellent for taping, layer, wrapper, and phase insulation. 1300 volt /mil dielectric strength. 36 yard rolls. Mil spec MIL-I-17205 Grade O.



WIDTH (IN.)	PART NUMBER .007 THICK	.010 THICK
1/2	SGVF-007-1/2	SGVF-010-1/2
3/4	SGVF-007-3/4	SGVF-010-3/4
1	SGVF-007-1	SGVF-010-1
1-1/4	SGVF-007-1-1/4	SGVF-010-1-1/4
1-1/2	SGVF-007-1-1/2	SGVF-010-1-1/2
1-3/4	SGVF-007-1-3/4	SGVF-010-1-3/4
2	SGVF-007-2	SGVF-010-2
2-1/4	SGVF-007-2-1/4	SGVF-010-2-1/4
2-1/2	SGVF-007-2-1/2	SGVF-010-2-1/2
3	SGVF-007-3	SGVF-010-3
3-1/2	SGVF-007-3-1/2	SGVF-010-3-1/2
4	SGVF-007-4	SGVF-010-4
4-1/2	SGVF-007-4-1/2	SGVF-010-4-1/2
5	SGVF-007-5	SGVF-010-5
5-1/2	SGVF-007-5-1/2	SGVF-010-5-1/2
6	SGVF-007-6	SGVF-010-6

VAR-H GLASS CLOTH CLASS H (180°C)

Continuous filament straight weave glass fabric .004" thick coated with a flexible insulating varnish. Excellent for layer and phase insulation. Works great as a wrapper. Supplied on 36 yard rolls 36 inches wide. Dusted with mica dust to make unrolling easy, for non-dusted add -ND to part number. Dielectric strength 1200-1400 volts per mil. Mil spec MIL-I-17205 Grade O.

THICKNESS (IN.)	BASE CLOTH THICKNESS (IN.)	PART NUMBER
.007	.004	VARH-007-4-RL
.010	.004	VARH-010-4-RL
.010	.007	VARH-010-7-RL
.012	.007	VARH-012-7-RL
.015	.004	VARH-015-4-RL
.015	.007	VARH-015-7-RL

NOMEX* 411 CLASS R (220°C) HERMETIC APPROVED



Un-calendered version of NOMEX* 410, absorbs varnish to provide better bonding for phase insulation applications. Sheets are 38" x 36". Rolls are 38" wide x 50 yards long. Mil spec MIL-I-24204A.

THICKNESS (IN.)	PART NUMBER
.007	NX-411-007-38X36
.007	NX-411-007-38IN
.010	NX-411-010-38X36
.010	NX-411-010-38IN
.015	NX-411-015-38X36
.015	NX-411-015-38IN
.023	NX-411-023-38X36
.023	NX-411-023-38IN

Step # 4

Because of the voltage difference from phase to phase the highest potential for shorting is between phases. It's a good



practice to use phase insulation on the end turns and slot separator between coils in the slot.

NOMEX* FORMED SEPARATORS HERMETIC APPROVED CLASS R (220°C)

Pre-formed NOMEX* separators are similar to wedges except that they are thinner and are perfectly suited for use as separators. Meets mil spec MIL-I-24204A. Supplied 250 feet per unit.

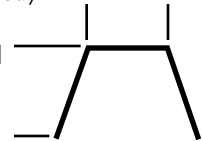

NOMEX* 10 MIL THICK

"A" (IN.)	"B" (IN.)	PART NUMBER
1/16	1/8	ANHT-10-4-8
5/64	3/32	ANHT-10-5-6
7/64	1/8	ANHT-10-7-8
1/8	1/8	ANHT-10-8-8
5/32	9/64	ANHT-10-10-9
5/32	7/32	ANHT-10-10-14
11/64	5/32	ANHT-10-11-10
3/16	3/16	ANHT-10-12-12
13/64	11/64	ANHT-10-13-11
7/32	17/64	ANHT-10-14-17
5/64	11/64	ANHT-10-15-11
15/64	15/64	ANHT-10-15-15
1/4	11/64	ANHT-10-16-11
17/64	15/64	ANHT-10-17-15
19/64	15/64	ANHT-10-19-15
5/16	9/32	ANHT-10-20-18
21/64	15/64	ANHT-10-21-15
23/64	1/4	ANHT-10-23-16
27/64	9/32	ANHT-10-27-18

CREASED SEPARATOR COILS

Creased separator coils are strips of insulation cut to width and pre-creased so they form easily. Available in a variety of grades and sizes. NOMEX* meets mil spec MIL-I-24204A, DMD meets mil spec MIL-I-22834.

NOMEX* and DMD are Hermetic approved.

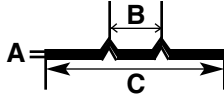

NOMEX* CLASS R (220°C)			
"A" (IN.)	"B" (IN.)	"C" (IN.)	PART NUMBER
.010	5/32	7/16	ANHTC-10-14-5
.010	3/16	9/16	ANHTC-10-18-6
.010	9/32	3/4	ANHTC-10-24-9
.010	3/8	15/16	ANHTC-10-30-12
.015	3/16	9/16	ANHTC-15-18-6
.015	9/32	3/4	ANHTC-15-24-9
.015	3/8	15/16	ANHTC-15-30-12
.020	9/32	3/4	ANHTC-20-24-9
.020	3/8	15/16	ANHTC-20-30-12

DMD CLASS F (155°C)

ADMD-11 IS 3-5-3 CONSTRUCTION
ADMD-15 IS 5-5-5 CONSTRUCTION

"A" (IN.)	"B" (IN.)	"C" (IN.)	PART NUMBER
.011	5/32	7/16	ADMD-11-14-5
.011	3/16	9/16	ADMD-11-18-6
.011	9/32	3/4	ADMD-11-24-9
.011	3/8	15/16	ADMD-11-30-12
.015	3/16	9/16	ADMD-15-18-6
.015	9/32	3/4	ADMD-15-24-9
.015	3/8	15/16	ADMD-15-30-12

RAG/MYLAR/RAG CLASS A (105°C)

ASRRM-10 IS 4-2-4 CONSTRUCTION
ASRRM-15 IS 5-5-5 CONSTRUCTION
ASRRM-20 IS 5-10-5 CONSTRUCTION

"A" (IN.)	"B" (IN.)	"C" (IN.)	PART NUMBER
.010	5/32	7/16	ASRRM-10-14-5
.010	3/16	9/16	ASRRM-10-18-6
.010	9/32	3/4	ASRRM-10-24-9
.010	3/8	15/16	ASRRM-10-30-12
.015	3/16	9/16	ASRRM-15-18-6
.015	9/32	3/4	ASRRM-15-24-9
.015	3/8	15/16	ASRRM-15-30-12
.020	9/32	3/4	ASRRM-20-24-9
.020	3/8	15/16	ASRRM-20-30-12



NOMEX* 15 MIL THICK

"A" (IN.)	"B" (IN.)	PART NUMBER
3/16	3/16	ANHT-15-12-12
15/64	11/64	ANHT-15-15-11
1/4	11/64	ANHT-15-16-11
19/64	15/64	ANHT-15-19-15
23/64	1/4	ANHT-15-23-16
27/64	9/32	ANHT-15-27-18

INTERMEDIATE INSULATION - WEDGES

Step # 5

Measure the width of the slot where the wedge is going to sit. Next choose a wedge size that will fill the slot width and hold the wire down in the slot. Then choose a wedge material that will match the operating temperature.

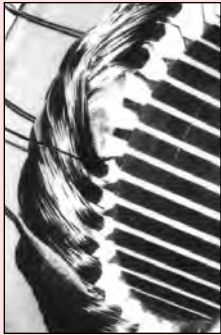

Wedge Packaging:

36" lengths packaged in 250' boxes
36" lengths in bulk packages

GET THE COMPETITIVE EDGE WITH OUR TOP QUALITY WEDGES!

NOMEX* **HERMETIC APPROVED** **CLASS R (220°C)**
Mil spec MIL-I-24204A. Made from NOMEX* 410 material these wedges will stand in and take the heat.

DMD **HERMETIC APPROVED** **CLASS F (155°C)**
Mil spec MIL-I-22834. DACRON* MYLAR* DACRON* material is exceptionally strong due to the MYLAR* sandwiched between two layers of DACRON*.

DUROID **HERMETIC APPROVED** **CLASS F (155°C)**
These wedges are made from Rogers Duroid 2300 which is a polyester fibre paper saturated with a heat resistant epoxy resin, fully densified and cured.

POLYESTER **HERMETIC APPROVED** **CLASS B (130°C)**
Tough polyester wedges are temperature resistant, chemical resistant, and have a high dielectric.

FIBER **HERMETIC APPROVED** **CLASS A (105°C)**
Mil spec MIL-I-695/F. Fiber wedges are rigid and snap easily after being inserted into the slot.

WOOD **CLASS A (105°C)**
Hard maple armature wedges are made of straight grained hard maple to resist splintering. They are wax coated and precision machined for speedy insertion into motor slots.

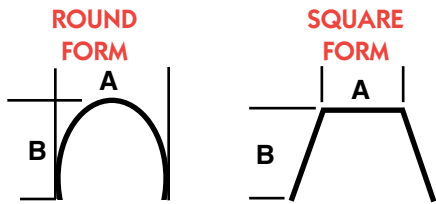

FIBER CLASS A (105°C)
Square Form 20 Mil Thick

"A" (IN.)	"B" (IN.)	OLD PART NUMBER	NEW PART NUMBER
7/64	1/8	LFAW-1	AFW-20-7-8
1/8	1/8	LFAW-7	AFW-20-8-8
11/64	5/32	LFAW-2	AFW-20-11-10
15/64	11/64	LFAW-10	AFW-20-15-11

Square Form 25 Mil Thick

"A" (IN.)	"B" (IN.)	OLD PART NUMBER	NEW PART NUMBER
5/32	7/32	LFAW-8	AFW-25-10-14
11/64	5/32	LFAW-9	AFW-25-11-10
1/4	11/64	LFAW-3B	AFW-25-16-11
19/64	15/64	LFAW-4	AFW-25-19-15
23/64	1/4	LFAW-5	AFW-25-23-16

Square Form 30 Mil Thick

"A" (IN.)	"B" (IN.)	OLD PART NUMBER	NEW PART NUMBER
27/64	9/32	LFAW-6	AFW-30-27-18

Round Form 20 Mil Thick

"A" (IN.)	"B" (IN.)	OLD PART NUMBER	NEW PART NUMBER
5/32	9/64	FAW-10	AFW-260

Round Form 30 Mil Thick

"A" (IN.)	"B" (IN.)	OLD PART NUMBER	NEW PART NUMBER
13/64	1/8	FAW-1	AFW-58
7/32	9/64	FAW-7	AFW-65
5/32	11/64	FAW-6	AFW-70
7/32	3/16	FAW-2	AFW-86
5/16	3/16	FAW-8	AFW-94
1/4	7/32	FAW-3	AFW-99
5/16	1/4	FAW-4	AFW-117
3/8	5/16	FAW-9	AFW-144

Round Form 40 Mil Thick

"A" (IN.)	"B" (IN.)	OLD PART NUMBER	NEW PART NUMBER
7/64	17/64	FAW-5	AFW-199

DMD CLASS F (155°C)
Square Form 20 Mil Thick

"A" (IN.)	"B" (IN.)	PART NUMBER
7/64	1/8	ADMD-20-7-8
1/8	1/8	ADMD-20-8-8
5/32	7/32	ADMD-20-10-14
11/64	5/32	ADMD-20-11-10
3/16	3/16	ADMD-20-12-12
13/64	11/64	ADMD-20-13-11
15/64	11/64	ADMD-20-15-11
15/64	15/64	ADMD-20-15-15
1/4	11/64	ADMD-20-16-11
17/64	15/64	ADMD-20-17-15
19/64	15/64	ADMD-20-19-15
23/64	1/4	ADMD-20-23-16
27/64	9/32	ADMD-20-27-18

Round Form 20 Mil Thick

"A" (IN.)	"B" (IN.)	PART NUMBER
13/64	1/8	ADMD-58-20
5/32	9/64	ADMD-60-20
7/32	9/64	ADMD-65-20
5/32	11/64	ADMD-70-20
7/32	3/16	ADMD-86-20
5/16	3/16	ADMD-94-20
1/4	7/32	ADMD-99-20
5/16	1/4	ADMD-117-20
3/8	5/16	ADMD-144-20
7/16	17/64	ADMD-199-20

DUROID CLASS F (155°C)
Square Form 25 Mil Thick

"A" (IN.)	"B" (IN.)	PART NUMBER
7/64	1/8	DFP-25-7-8-H
1/8	1/8	DFP-25-8-8-H
11/64	5/32	DFP-25-11-10-H
15/64	11/64	DFP-25-15-11-H
5/32	7/32	DFP-25-10-14-H
1/4	11/64	DFP-25-16-11-H
17/64	15/64	DFP-25-17-15-H
19/64	15/64	DFP-25-19-15-H
23/64	1/4	DFP-25-23-16-H
27/64	9/32	DFP-25-27-18-H

Round Form 25 Mil Thick

"A" (IN.)	"B" (IN.)	PART NUMBER
13/64	1/8	DFP-58-25-H
5/32	9/64	DFP-60-25-H
7/32	9/64	DFP-65-25-H
5/32	11/64	DFP-70-25-H
7/32	3/16	DFP-86-25-H
5/16	3/16	DFP-94-25-H
1/4	7/32	DFP-99-25-H
5/16	1/4	DFP-117-25-H
3/8	5/16	DFP-144-25-H
7/16	17/64	DFP-199-25-H

* Nomex, Dacron and Mylar are registered trademarks of E.I. DuPont de Nemours.

INTERMEDIATE INSULATION - WEDGES

NOMEX* CLASS R (220°C)

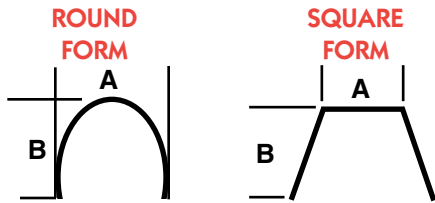

Wedge Packaging:

36" lengths packaged in 250' boxes
36" lengths in bulk packages

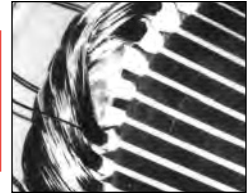

Square Form 20 Mil Thick

"A" (IN.)	"B" (IN.)	PART NUMBER
7/64	1/8	ANHT-20-7-8
1/8	1/8	ANHT-20-8-8
9/64	5/32	ANHT-20-9-10
5/32	5/32	ANHT-20-10-10
5/32	7/32	ANHT-20-10-14
11/64	5/32	ANHT-20-11-10
3/16	3/16	ANHT-20-12-12
13/94	11/64	ANHT-20-13-11
15/64	11/64	ANHT-20-15-11
15/64	15/64	ANHT-20-15-15
1/4	11/64	ANHT-20-16-11
17/64	13/64	ANHT-20-17-13
17/64	15/64	ANHT-20-17-15
19/64	15/64	ANHT-20-19-15
23/64	1/4	ANHT-20-23-16
27/64	9/32	ANHT-20-27-18

Square Form 24 Mil Thick

"A" (IN.)	"B" (IN.)	PART NUMBER
7/64	1/8	ANHT-24-7-8
1/8	1/8	ANHT-24-8-8
9/64	1/8	ANHT-24-9-8
5/32	7/32	ANHT-24-10-14
11/64	5/32	ANHT-24-11-10
3/16	3/16	ANHT-24-12-12
13/64	11/64	ANHT-24-13-11
7/32	3/16	ANHT-24-14-12
15/64	11/64	ANHT-24-15-11
15/64	15/64	ANHT-24-15-15
1/4	11/64	ANHT-24-16-11
17/64	13/64	ANHT-24-17-13
17/64	15/64	ANHT-24-17-15
19/64	15/64	ANHT-24-19-15
21/64	15/64	ANHT-24-21-15
23/64	1/4	ANHT-24-23-16
27/64	9/32	ANHT-24-27-18
1/2	9/32	ANHT-24-32-18

Round Form 20 Mil Thick

"A" (IN.)	"B" (IN.)	PART NUMBER
13/64	1/8	ANHT-58-20
5/32	9/64	ANHT-60-20
7/32	9/64	ANHT-65-20
5/32	11/64	ANHT-70-20
7/32	3/16	ANHT-86-20
5/16	3/16	ANHT-94-20
1/4	7/32	ANHT-99-20
5/16	1/4	ANHT-117-20
3/8	5/16	ANHT-144-20
7/16	17/64	ANHT-199-20

Round Form 24 Mil Thick

"A" (IN.)	"B" (IN.)	PART NUMBER
13/64	1/8	ANHT-58-24
5/32	9/64	ANHT-60-24
7/32	9/64	ANHT-65-24
5/32	11/64	ANHT-70-24
7/32	3/16	ANHT-86-24
5/16	3/16	ANHT-94-24
1/4	7/32	ANHT-99-24
5/16	1/4	ANHT-117-24
3/8	5/16	ANHT-144-24
7/16	17/64	ANHT-199-24

Square Form 30 Mil Thick

"A" (IN.)	"B" (IN.)	PART NUMBER
1/8	1/8	ANHT-30-8-8
5/32	7/32	ANHT-30-10-14
11/64	5/32	ANHT-30-11-10
15/64	11/64	ANHT-30-15-11
15/64	15/64	ANHT-30-15-15
1/4	11/64	ANHT-30-16-11
19/64	15/64	ANHT-30-19-15
23/64	1/4	ANHT-30-23-16
27/64	9/32	ANHT-30-27-18

Round Form 30 Mil Thick

"A" (IN.)	"B" (IN.)	PART NUMBER
5/32	9/64	ANHT-60-30
7/32	9/64	ANHT-65-30
5/32	11/64	ANHT-70-30
7/32	3/16	ANHT-86-30
5/16	3/16	ANHT-94-30
1/4	7/32	ANHT-99-30
5/16	1/4	ANHT-117-30
3/8	5/16	ANHT-144-30
7/16	17/64	ANHT-199-30

* Nomex is a registered trademark of E.I. DuPont de Nemours.

INTERMEDIATE INSULATION - WEDGES

WOOD CLASS A (105°C)



SIZE W" X TH" (IN.)	STYLE	PART NUMBER
1/8 X 5/64	1	AWW-1220
1/8 X 3/32	1	AWW-1230
5/32 X 5/64	1	AWW-121
3/16 X 5/64	1	AWW-122
5/32 X 3/32	1	AWW-131
3/16 X 3/32	1	AWW-132
7/32 X 3/32	1	AWW-133
1/4 X 3/32	1	AWW-134
9/32 X 3/32	1	AWW-135
3/16 X 1/8	1	AWW-152
7/32 X 1/8	1	AWW-153
1/4 X 1/8	1	AWW-154
9/32 X 1/8	1	AWW-155
5/16 X 1/8	1	AWW-156
3/8 X 1/8	1	AWW-158
7/16 X 1/8	1	AWW-160
5/32 X 1/8	2	AWW-251
7/32 X 1/8	2	AWW-253
1/4 X 1/8	2	AWW-254
5/16 X 1/8	2	AWW-256
3/8 X 1/8	2	AWW-258
7/32 X 3/32	3	AWW-333
1/4 X 3/16	3	AWW-374
3/16 X 1/16	4	AWW-412
5/32 X 1/8	4	AWW-451
3/16 X 1/8	4	AWW-452
7/32 X 1/8	4	AWW-453
1/4 X 1/8	4	AWW-454
9/32 X 1/8	4	AWW-455
5/16 X 1/8	4	AWW-456
11/32 X 1/8	4	AWW-457
3/8 X 1/8	4	AWW-458
3/16 X 3/16	4	AWW-472
1/4 X 3/16	4	AWW-474
9/32 X 3/16	4	AWW-475
5/16 X 3/16	4	AWW-476
11/32 X 3/16	4	AWW-477

SIZE W" X TH" (IN.)	STYLE	PART NUMBER
9/32 X 1/8	5	AWW-555
5/32 X 5/64	6	AWW-621
3/16 X 3/32	6	AWW-632
1/4 X 3/32	6	AWW-634
3/16 X 7/64	6	AWW-642
7/32 X 7/64	6	AWW-643
5/16 X 7/64	6	AWW-646
7/32 X 1/8	6	AWW-653
5/16 X 1/8	6	AWW-656
3/8 X 1/8	6	AWW-658
3/16 X 3/32	7	AWW-732
11/64 X 7/64	7	AWW-742-A
13/64 X 1/8	7	AWW-752
13/64 X 1/8	7	AWW-753-A
15/64 X 1/8	7	AWW-754-A
5/16 X 5/16	8	AWW-816
1/4 X 3/32	8	AWW-834
5/16 X 3/32	8	AWW-836
5/16 X 1/8	8	AWW-856
3/8 X 1/8	8	AWW-858



SIZE W" X TH" (IN.)	STYLE	PART NUMBER
1/4 X 1/4	SQUARE	AWW-494
3/8 X 3/8	SQUARE	AWW-3838
1/2 X 1/2	SQUARE	AWW-1212

Wood Wedge Packaging:

36" lengths packaged in 500' bundles

Polyester Wedge Packaging:

36" lengths packaged in 250' boxes

36" lengths in bulk packages

POLYESTER CLASS B (130°C)

Square Form 10 Mil Thick

"A" (IN.)	"B" (IN.)	PART NUMBER
1/8	1/8	AMFC-10-8-8
1/8	5/32	AMFC-10-8-10
5/32	3/16	AMFC-10-10-12
3/16	3/16	AMFC-10-12-12
15/64	11/64	AMFC-10-15-11

Round Form 10 Mil Thick

"A" (IN.)	"B" (IN.)	PART NUMBER
7/32	3/16	AMFC-86-10
1/4	7/32	AMFC-99-10
5/16	1/4	AMFC-117-10
3/8	5/16	AMFC-144-10

Square Form 14 Mil Thick

"A" (IN.)	"B" (IN.)	PART NUMBER
11/64	5/32	AMFC-14-11-10
5/32	7/32	AMFC-14-10-14
19/64	15/64	AMFC-14-10-12
3/16	3/16	AMFC-14-19-15
23/64	1/4	AMFC-14-23-16

Round Form 14 Mil Thick

"A" (IN.)	"B" (IN.)	PART NUMBER
7/32	3/16	AMFC-86-14
1/4	7/32	AMFC-99-14
5/16	1/4	AMFC-117-14
3/8	5/16	AMFC-144-14

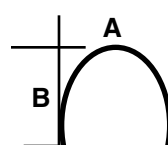

ROUND
FORM

SQUARE
FORM

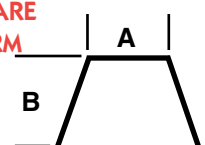

INTERMEDIATE INSULATION - TOPSTICKS

GLASTIC^{***} HERMETIC APPROVED CLASS H (180°C)

Glass reinforced polyester topsticks are available in a variety of sizes. Pultruded with continuous glass fibers they gain much of their strength from the outer fiberglass layer. Simply determine the size needed to fit the slot and cut to length. Machining to width is not recommended and the topsticks are designed to be used only in stators, not rotors. 36 in. long, 102 ft. per package.



MELAMINE CLASS B (150°C)

Made from G-9 melamine, these topsticks are the answer for both stators and rotating apparatus. They come in a variety of sizes and are suitable to be machined to width. G-9 material meets mil spec MIL-P-15037-GME.



M-M & M
ELECTRICAL SUPPLY,
INC.

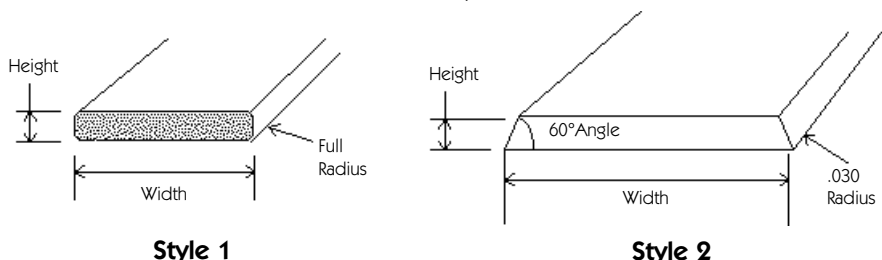

GLASTIC^{***} TOPSTICKS

MELAMINE TOPSTICKS

.072 THICK STYLE 1	
WIDTH (IN.)	PART NUMBER
.317	GT-6072317
.337	GT-6072337
.347	GT-6072347
.352	GT-6072352
.357	GT-6072357
.377	GT-6072377
.382	GT-6072382
.387	GT-6072387
.397	GT-6072397
.407	GT-6072407
.412	GT-6072412
.417	GT-6072417
.432	GT-6072432
.442	GT-6072442
.090 THICK STYLE 1	
WIDTH (IN.)	PART NUMBER
.452	GT-6090452
.467	GT-6090467
.477	GT-6090477
.482	GT-6090482
.487	GT-6090487
.492	GT-6090492
.497	GT-6090497
.502	GT-6090502
.522	GT-6090522
.542	GT-6090542
.552	GT-6090552
.562	GT-6090562



.090 THICK STYLE 1 (cont.)	
WIDTH (IN.)	PART NUMBER
.572	GT-6090572
.577	GT-6090577
.602	GT-6090602
.617	GT-6090617
.622	GT-6060622
.627	GT-6090627
.662	GT-6090662
.762	GT-6090762
.125 THICK STYLE 2	
WIDTH (IN.)	PART NUMBER
.527	GT-6125527
.532	GT-6125532
.582	GT-6125582
.587	GT-6125587
.607	GT-6125607
.612	GT-6125612
.667	GT-6125667
.672	GT-6125672
.682	GT-6125682

.072 THICK STYLE 1	
WIDTH (IN.)	PART NUMBER
.290	G-9072290
.310	G-9072310
.317	G-9072317
.330	G-9072330
.337	G-9072337
.347	G-9072347
.352	G-9072352
.357	G-9072357
.367	G-9072367
.377	G-9072377
.382	G-9072382
.387	G-9072387
.397	G-9072397
.407	G-9072407
.412	G-9072412
.417	G-9072417
.425	G-9072425
.432	G-9072432
.442	G-9072442
.090 THICK STYLE 1	
WIDTH (IN.)	PART NUMBER
.452	G-9090452
.462	G-9090462
.467	G-9090467
.477	G-9090477
.482	G-9090482
.487	G-9090487
.492	G-9090492
.497	G-9090497

.090 THICK STYLE 1 (cont.)	
WIDTH (IN.)	PART NUMBER
.502	G-9090502
.522	G-9090522
.537	G-9090537
.542	G-9090542
.552	G-9090552
.562	G-9090562
.590	G-9090590
.602	G-9090602
.617	G-9090617
.622	G-9090622
.627	G-9090627
.632	G-9090632
.662	G-9090662
.762	G-9090762
.790	G-9090790
.125 THICK STYLE 2	
WIDTH (IN.)	PART NUMBER
.400	G-9125400
.527	G-9125527
.532	G-9125532
.582	G-9125582
.587	G-9125587
.607	G-9125607
.612	G-9125612
.667	G-9125667
.672	G-9125672
.682	G-9125682
.687	G-9125687

*** Glastic is a registered trademark of The Glastic Corporation.

CONNECTION INSULATION - SLEEVING & TUBING

ACRYLIC CLASS F (155°C) SLEEVING

Acrylic-coated fiberglass sleeving offers excellent resistance to cracking, splitting, abrasion, and cut through. It provides resistance to acids and most organic solvents and is compatible with most wire enamels.

SUFLEX® ACRYFLEX-F®

Acrylic resin coating a finely braided fiberglass sleeving. Meets mil spec MIL-I-003190/3. Grade C has dielectric strength of 2500 volts. Grade A has dielectric strength of 7000 volts. UL & CSA listed. Standard color is natural (white).

BENTLEY HARRIS

Polyacrylate resin coated fiberglass. Meets mil spec MIL-I-3190. Grade C has dielectric strength up to 2500 volts. Grade A has dielectric strength of 7000 volts. UL & CSA listed. Standard color is natural (white). Also available in black, blue, green, red and yellow. Spools are the standard put-up, 36" lengths are available.

SILICONE RUBBER SLEEVING CLASS H (200°C)

This sleeving will remain flexible at low or high temperatures. Glass braid has a silicone rubber coating. Silicone rubber exhibits excellent corona resistance making it a good choice for high voltage applications. Silicone rubber also exhibits excellent ozone resistance, making it a perfect choice for lead insulation for motors, coils, and transformers.

SUFLEX® FLEXICONE®

Standard color is natural (white). A specially formulated high temperature silicone rubber elastomer bonded to fiberglass sleeving. Grade C has 2500 volt dielectric, Grade A has 7000 volt dielectric. Meets mil spec MIL-I-003190D & QPL listed MIL-I-18057. UL & CSA listed, NEMA VS-1.

BENTLEY HARRIS

Standard color is amber/transparent. Other colors are available with minimum quantities. Grade C rated at 2500 volt dielectric. Grade A rated at 7000 volt dielectric. Both meet mil spec Mil-I-3190/C, NEMA spec VS-1, and UL 1441.

ACRYLIC SLEEVING

SUFLEX® ACRYFLEX-F®

INSIDE DIA. (IN.)	SPOOL LENGTH (FT.)	PART NUMBER
.027	500	0130022111
.034	500	0130020111
.042	500	0130018111
.047	500	0130017111
.053	500	0130016111
.059	500	0130015111
.066	500	0130014111
.076	250	0130013111
.085	200	0130012111
.095	250	0130011111
.106	250	0130010111
.118	250	0130009111
.133	250	0130008111
.148	250	0130007111
.166	250	0130006111
.186	250	0130005111
.208	250	0130004111
.234	250	0130003111
.263	250	0130002111
.294	100	0130001111
.338	100	0130000111
.387	100	0130375111
.450	100	0130438111
.512	50	0130500111
.640	50	0130625111
.768	50	0130750111
.893	50	0130875111
1.018	50	0131000111

BENTLEY HARRIS ACRYL C

INSIDE DIA. (IN.)	SPOOL LENGTH (FT.)	PART NUMBER
.027	1000	ACR-C-22-NAT-SPL
.034	1000	ACR-C-20-NAT-SPL
.038	1000	ACR-C-19-NAT-SPL
.042	1000	ACR-C-18-NAT-SPL
.047	500	ACR-C-17-NAT-SPL
.053	500	ACR-C-16-NAT-SPL
.059	500	ACR-C-15-NAT-SPL
.066	500	ACR-C-14-NAT-SPL
.076	500	ACR-C-13-NAT-SPL
.085	500	ACR-C-12-NAT-SPL
.095	500	ACR-C-11-NAT-SPL
.106	500	ACR-C-10-NAT-SPL
.118	250	ACR-C-9-NAT-SPL
.133	250	ACR-C-8-NAT-SPL
.148	250	ACR-C-7-NAT-SPL
.166	250	ACR-C-6-NAT-SPL
.186	200	ACR-C-5-NAT-SPL
.208	200	ACR-C-4-NAT-SPL
.234	200	ACR-C-3-NAT-SPL
.263	200	ACR-C-2-NAT-SPL
.294	125	ACR-C-1-NAT-SPL
.330	125	ACR-C-0-NAT-SPL
.375	125	ACR-C-3/8-NAT-SPL
.437	50	ACR-C-7/16-NAT-SPL
.500	50	ACR-C-1/2-NAT-SPL
.625	50	ACR-C-5/8-NAT-SPL
.750	50	ACR-C-3/4-NAT-SPL
.875	50	ACR-C-7/8-NAT-SPL
1.00	50	ACR-C-1IN-NAT-SPL

SILICONE SLEEVING

SUFLEX® FLEXICONE®

INSIDE DIA. (IN.)	SPOOL LENGTH (FT.)	PART NUMBER
.027	500	2430022111
.034	500	2430020111
.042	500	2430018111
.047	500	2430017111
.053	500	2430016111
.059	500	2430015111
.066	500	2430014111
.076	250	2430243111
.085	200	2430012111
.095	250	2430011111
.106	250	2430010111
.118	250	2430009111
.133	250	2430008111
.148	250	2430007111
.166	250	2430006111
.186	250	2430005111
.208	250	2430004111
.234	250	2430003111
.263	250	2430002111
.294	100	2430001111
.330	100	2430000111
.375	100	2430375111
.437	100	2430438111
.500	50	2430500111
.625	50	2430625111
.750	50	2430750111
.875	50	2430875111
1.00	50	2431000111

BENTLEY HARRIS

INSIDE DIA. (IN.)	SPOOL LENGTH (FT.)	PART NUMBER
.027	1000	XL200-C-22-NAT
.034	1000	XL200-C-20-NAT
.038	1000	XL200-C-19-NAT
.042	1000	XL200-C-18-NAT
.047	500	XL200-C-17-NAT
.053	500	XL200-C-16-NAT
.059	500	XL200-C-15-NAT
.066	500	XL200-C-14-NAT
.076	500	XL200-C-13-NAT
.085	500	XL200-C-12-NAT
.095	500	XL200-C-11-NAT
.106	500	XL200-C-10-NAT
.118	250	XL200-C-9-NAT
.133	250	XL200-C-8-NAT
.148	250	XL200-C-7-NAT
.166	200	XL200-C-6-NAT
.186	200	XL200-C-5-NAT
.208	200	XL200-C-4-NAT
.234	200	XL200-C-3-NAT
.263	125	XL200-C-2-NAT
.294	125	XL200-C-1-NAT
.330	125	XL200-C-0-NAT
.375	50	XL200-C-3/8-NAT
.437	50	XL200-C-7/16-NAT
.500	50	XL200-C-1/2-NAT
.625	50	XL200-C-5/8-NAT
.750	50	XL200-C-3/4-NAT
.875	50	XL200-C-7/8-NAT
1.00	50	XL200-C-1IN-NAT



Voltage Rating Codes

Grade A = 7000 Volts
Grade C = 2500 Volts



BentleyHarris

CONNECTION INSULATION - SLEEVING & TUBING

VPI SLEEVING CLASS F (155°C) SUFLEX® ACRYFLEX® VPI-NF SLEEVING

VPI-NF is a carefully engineered high dielectric sleeving specifically designed for VPI impregnation. The overbraid is a full 1/32" thick and completely saturant-free to provide maximum resin absorption. The average dielectric strength before impregnation is 8500 volt. Available only in spools, natural color (white), and Grade A. Meets mil spec MIL-3190/3 and NEMA VS-1 Type 6.

BENTLEY HARRIS ACRYL VPI O/B

Ben-Har Acryl VPI-OB combines a Grade A acrylic sleeving with a fiberglass overbraid to form a permanent non-slip multi-walled sleeving. The outer fiberglass layer absorbs resin resulting in maximum dielectric strength. Available only in spools, Natural color (off white), and Grade A dielectric rating.

BENTLEY HARRIS ACRYL VPI

Ben-Har acryl VPI-A sleeving is a low density heavy wall fiberglass sleeving with an acrylic resin over coat. The heavy wall sleeving is designed to absorb as much as twice the resin of conventional sleeveings. Available only in Grade A+ (7000 volt) rating, yellow color and 36" lengths.

VPI OVERBRAID

SUFLEX® / ACRYFLEX® VPI-NF

BENTLEY HARRIS

NOM (IN.)	SPOOL LENGTH	PART NUMBER	SPOOL LENGTH	PART NUMBER
.133	250	1610008101	250	ACR-VPI-O/B-8-NA
.148	250	1610007101	250	ACR-VPI-O/B-7-NA
.166	200	1610006101	250	ACR-VPI-O/B-6-NA
.186	100	1610005101	250	ACR-VPI-O/B-5-NA
.208	100	1610004101	250	ACR-VPI-O/B-4-NA
.234	100	1610003101	250	ACR-VPI-O/B-3-NA
.263	100	1610002101	250	ACR-VPI-O/B-2-NA
.294	100	1610001101	100	ACR-VPI-O/B-1-NA
.330	100	1610000101	100	ACR-VPI-O/B-0-NA
.375	50	1610375101	100	ACR-VPI-O/B-3/8-NA
.500	50	1610500101	50	ACR-VPI-O/B-1/2-NA



ACRYL VPI

BENTLEY HARRIS

I.D. (IN.)	PKG. SIZE	PART NUMBER
.125	126	ACR-VPI-1/8-YL-36
.187	126	ACR-VPI-3/16-YL-36
.250	102	ACR-VPI-1/4-YL-36
.312	102	ACR-VPI-5/16-YL-36
.375	51	ACR-VPI-3/8-YL-36
.437	51	ACR-VPI-7/16-YL-36
.500	51	ACR-VPI-1/2-YL-36
.625	51	ACR-VPI-5/8-YL-36
.750	51	ACR-VPI-3/4-YL-36
.875	51	ACR-VPI-7/8-YL-36
1.00	51	ACR-VPI-1IN-YL-36
1.25	51	ACR-VPI-1-1/4-YL-36

3M HEAT SHRINK SLEEVING CLASS B (135°C)

Convenient packages of 3M famous FP-301 heat shrink sleeving. Right size 25 ft. reels inside dispenser boxes. FP-301 is a polyolefin material with a 2:1 shrink ratio. It is mechanically tough and has excellent electrical, physical and chemical properties. UL & CSA listed. Mil spec MIL-I-23053/5. Black in color.

EXPANDED I.D. (IN.)	RECOVERED I.D. (IN.)	PART NUMBER
1/16	1/32	FP-063-BK-25
3/32	3/64	FP-093-BK-25
1/8	1/16	FP-125-BK-25
3/16	3/32	FP-187-BK-25
1/4	1/8	FP-250-BK-25
3/8	3/16	FP-375-BK-25
1/2	1/4	FP-500-BK-25
3/4	3/8	FP-750-BK-25
1	1/2	FP-1000-BK-25

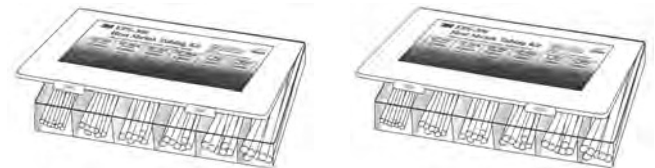

HEAT SHRINK TUBING KITS



The 3M EPS-300 Heat Shrink Tubing Kit (Part# EPS-300-KIT) is an assortment of adhesive lined, flexible, polyolefin heat shrink tubing. Each kit contains the following:

DESCRIPTION	SIZE	# OF 6" PIECES
EPS-300 RED	1/2"(12,70mm)	12
EPS-300 BLACK	1/2"(12,70mm)	12
EPS-300 RED	3/4"(19,05mm)	6
EPS-300 BLACK	3/4"(19,05mm)	6
EPS-300 RED	1"(25,40mm)	3
EPS-300 BLACK	1"(25,40mm)	3

The 3M FP-301 Heat Shrink Tubing Kit (Part# FP-301-KIT) is a versatile assortment of flexible polyolefin heat shrink tubing. The kit contains a total of 133 pieces of 6 inch (152, 4mm) lengths of heat shrink tubing in six different diameters and seven colors: black, red, white, yellow, blue, green, and clear. The kit contents, by expanded diameter, are as follows:

SIZE	QUANTITY
3/32" (2,36mm)	5 each of 7 colors
1/8" (3,18mm)	4 each of 7 colors
3/16" (4,75mm)	3 each of 7 colors
1/4" (6,35mm)	3 each of 7 colors
3/8" (9,53mm)	2 each of 7 colors
1/2" (12,70mm)	2 each of 7 colors

HERMETIC TUBING

A combination of Mylar* wrapped around and bonded to an inner layer of NOMEX* with a polyester adhesive. This produces a unique tubing that is resistant to heat, chemical resistant, and has a high dielectric strength (approx. 7800 volts). NMT tubing has low extractables which makes it an excellent choice for hermetic applications. Available only in 3 ft. lengths.

I.D. (IN.)	PKG. SIZE	PART NUMBER
.068	300	NMT-14
.085	300	NMT-12
.096	300	NMT-11
.107	300	NMT-10
.119	300	NMT-9
.135	300	NMT-8
.170	201	NMT-6
.190	201	NMT-5
.214	201	NMT-4
.239	201	NMT-3
.268	201	NMT-2
.300	201	NMT-1
.368	102	NMT-0
.387	102	NMT-3/8
.450	102	NMT-7/16
.512	102	NMT-1/2
.768	102	NMT-3/4

CONNECTION INSULATION - LEAD WIRE

SILICONE RUBBER GLASS BRAID 600 VOLT CLASS H (200°C)



The silicone insulation strips clean and easily while the glass braid provides additional abrasion resistance and is treated to resist fraying. Suitable for class H systems. UL & CSA listed. Meets the VW-1 vertical flame test.

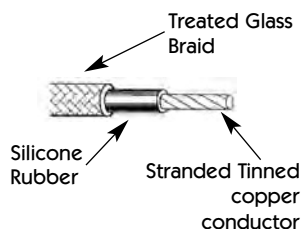

AWG (STRANDING)	AMP ** CAPACITY	NOMINAL O.D. (IN.)	AVAILABLE COLORS	AVAILABLE PUT UPS (FT.)	PART NUMBER
18 (7X26)	28	.133	9,10	500,6000	MLW-32418-***-XXX
16 (7X24)	35	.145	9,10	500,6000	MLW-32416-***-XXX
14 (7X22)	54	.167	9,10	500,4000	MLW-32414-***-XXX
12 (19X24-1/2)	68	.190	9,10	500,3000	MLW-32412-***-XXX
10 (19X22-1/2)	90	.238	9,10	500,3000	MLW-32410-***-XXX
8 (54X25)	124	.313	9,10	100,500,3000	MLW-30808-***-XXX
6 (84X25)	165	.368	9,10	100,500,2000	MLW-30806-***-XXX
4 (105X24)	220	.424	9,10	250,2000	MLW-30804-***-XXX
2 (163X24)	293	.496	9,10	250	MLW-30802-***-XXX
1 (210X24)	344	.622	9,10	100,250	MLW-30801-***-XXX
1/0 (262X24)	399	.670	9,10	100,250	MLW-30890-***-XXX
2/0 (504X26)	467	.727	9	50,100,250	MLW-30800-WHT-XXX
3/0 (630X26)	546	.795	9	250	MLW-30830-WHT-XXX
4/0 (805X26)	629	.855	9	50,250	MLW-30840-WHT-XXX

Maximum values for single conductor in free air @ 30°C. * Insert code for color. XXX Insert code for spool length. Choose code from available put ups column.

HERMETIC 600 VOLT CLASS B (125°C)



Combination of polyester fibers and polyester film insulation offers an improved wire for use in refrigerants. Suitable for Class B applications. Contains low extractables for use in hermetically sealed motors. UL-5170 listed, except 2 AWG.

AWG (STRANDING)	AMP ** CAPACITY	NOMINAL O.D. (IN.)	AVAILABLE COLORS	AVAILABLE PUT UPS (FT.)	PART NUMBER
16 (105X36)	28	.099	9,125,132	500	MLW-34516-***-500
14 (168X36)	42	.116	9,125,132	500	MLW-34514-***-500
12 (267X36)	55	.143	9,125,132	500	MLW-34512-***-500
10 (417X36)	72	.172	9,125,132	500	MLW-33910-***-500
8 (665X36)	97	.215	9	250	MLW-33908-WHT-250
6 (1050X36)	131	.265	9	250	MLW-33906-WHT-250
4 (1057X34)	172	.300	9	100	MLW-33904-WHT-100
2 (1680X34)	232	.380	9	100	MLW-33902-WHT-100

Maximum values for single conductor in free air @ 30°C. * Insert code for color. XXX Insert code for spool length. Choose code from available put ups column.

HYPALON* 600 VOLT CLASS A (105°C)



Long time industry standard suitable for use in Class B systems. Excellent heat resistance, color stability, and electrical properties. Good flexibility. UL & CSA listed. Rated 600 volt UL & CSA except 10 AWG through 4/0 rated 300 volt CSA.

AWG (STRANDING)	AMP ** CAPACITY	NOMINAL O.D. (IN.)	AVAILABLE COLORS	AVAILABLE PUT UPS (FT.)	PART NUMBER
18 (16X30)	20	.142	2,4,5,7,8,9,10,13	100,500,5000	MLW-34418-***-XXX
16 (26X30)	26	.155	2,4,5,8,9,10,13	100,500,4000	MLW-34416-***-XXX
14 (41X30)	39	.170	2,5,8,10	100,500,4000	MLW-34414-***-XXX
12 (65X30)	51	.190	2,5,6,8,10	100,500,3000	MLW-34412-***-XXX
10 (65X28)	67	.209	8,10	100,500,2000	MLW-34410-***-XXX
8 (84X27)	90	.290	8,10	100,250	MLW-34408-***-XXX
6 (84X25)	121	.343	8,10	100,250,1000	MLW-34406-***-XXX
4 (105X24)	160	.399	10	100,250,500	MLW-34404-BLK*-XXX
3 (133X24)	180	.420	8,10	500	MLW-34403-***-XXX
2 (163X24)	215	.454	8,10	100,250,500	MLW-34402-***-XXX
1 (210X24)	247	.557	8,10	50,100,250	MLW-34401-***-XXX
1/0 (262X24)	286	.607	8,10	50,100,250	MLW-34490-***-XXX
2/0 (504X26)	329	.668	8,10	50,100,250	MLW-34400-***-XXX
3/0 (630X26)	380	.732	8,10	50,250	MLW-34430-***-XXX
4/0 (805X26)	446	.839	8,10	50,250	MLW-34440-***-XXX

XXX Insert code for spool length. Choose code from available put ups column.

* Hypalon is a registered trademark of E.I. DuPont de Nemours.

COLOR CODE CHART - All colors not available in all putups

2 = RED (RED) 4 = YELLOW (YEL) 5 = GREEN (GRN) 7 = VIOLET (VIO) 8 = GRAY (GRY) 9 = WHITE (WHT)
 10 = BLACK (BLK) 13 = DARK BLUE (BLU) 125 = WHITE W/RED TRACER (WTRD) 132 = WHITE W/BLACK TRACER (WTBK)

CONNECTION INSULATION - LEAD WIRE

EXAR® 3562*

600 VOLT

CLASS F

(150°C)



A revolutionary new lead wire with a small outside diameter. EXAR 3562 offers you a big advantage over other lead wires by giving you a 39% smaller outside diameter. The benefits are obvious, the smaller OD allows for easier wire

AWG (STRANDING)	AMP ** CAPACITY	NOMINAL O.D. (IN.)	AVAILABLE COLORS	AVAILABLE PUT UPS (FT.)	PART NUMBER
20 (19X32)	15	.076	10	500,5000	XR3562-20-BLK-XXX
18 (19X30)	21	.084	10	500,5000	XR3562-18-BLK-XXX
16 (26X30)	28	.094	10	500,1000	XR3562-16-BLK-XXX
14 (41X30)	46	.108	10	500,1000	XR3562-14-BLK-XXX
12 (65X30)	60	.126	10	500,1000	XR3562-12-BLK-XXX

XXX Insert code for spool length. Choose code from available put ups column

routing in tight spaces. EXAR 3562 performs well at any temperature from -25°C to 150°C. The KYNAR FLEX outer jacket is exceptionally resistant to abrasion and impact damage. Check out the advantages for yourself! UL listed.

EXAR† 150*

600 VOLT

CLASS F

(150°C)



EXAR 150 is a cross-linked polymeric insulation that does not produce corrosive gas at elevated temperatures. It possesses outstanding mechanical and electrical properties. Compatible with most types of magnet wire and varnishes, and withstands bake temperatures up to 190°C. UL listing 3271/3289 & CSA listing 1251/1503.

AWG (STRANDING)	AMP ** CAPACITY	NOMINAL O.D. (IN.)	AVAILABLE COLORS	AVAILABLE PUT UPS (FT.)	PART NUMBER
18 (16X30)	21	.106	2,5,9,10	500,1000,5000	XR-00218-***-XXX
16 (26X30)	28	.118	2,5,9,10	500,1000,5000	XR-00216-***-XXX
14 (41X30)	46	.132	2,9,10	500,1000,5000	XR-00214-***-XXX
12 (65X30)	60	.149	9,10	500,1000	XR-00212-***-XXX
10 (65X28)	80	.171	10	500,1000	XR-00210-BLK-XXX
8 (84X27)	106	.237	10	500,1000	XR-00208-BLK-XXX
6 (84X25)	155	.303	10	250,500,1000	XR-00206-BLK-XXX
4 (133X25)	190	.383	10	250,500	XR-00204-BLK-XXX
2 (259/26)	255	.443	10	125,250,500	XR-00202-BLK-XXX
1 (259/25)	293	.532	10	125,250,500	XR-00201-BLK-XXX
1/0 (259/24)	339	.584	10	125,250	XR-00290-BLK-XXX
2/0 (259/23)	390	.625	10	125,250	XR-00200-BLK-XXX
3/0 (259/22)	451	.680	10	100,250	XR-00230-BLK-XXX
4/0 (259/21)	529	.746	10	125,250	XR-00240-BLK-XXX

***Insert letter code for color. XXX Insert code for spool length. Choose code from available put ups column.

HYPALON*

600 VOLT

CLASS A

(105°C)



Long time industry standard suitable for use in Class B systems. Excellent heat resistance, color stability, and electrical properties. Good flexibility. UL & CSA listed Rated 600 volt UL3191(18-10), UL3192 (8-2), UL3193 (1-4/0) & CSA1053(18-12) CSA1052 (10-4/0); CSA 1052 rated only at 300V.

AWG (STRANDING)	AMP ** CAPACITY	NOMINAL O.D. (IN.)	AVAILABLE COLORS	AVAILABLE PUT UPS (FT.)	PART NUMBER
18 (16X30)	20	.144	8	500	W53372V18-088
16 (26X30)	26	.157	8	500	W53372V16-088
14 (41X30)	39	.172	8	250	W53372V14-088
12 (65X30)	51	.196	8	250	W53372V12-088
10 (105X30)	67	.226	8	200	W53372V10-088
8 (7X19/29)	90	.296	8	250	W53337O08-088
6 (7X19/27)	121	.338	8	100	W53337O06-088
4 (7X19/25)	160	.391	8	100	W53327O04-088
2 (7X19/23)	215	.460	8	50	W53357O02-088
1 (7X37/25)	247	.535	8	50	W53358O01-088
1/0 (7X37/24)	286	.631	8	50	W53358O51-088
2/0 (7X37/23)	329	.668	8	50	W53358O52-088
3/0 (7X37/22)	380	.685	8	50	W53358O53-088
4/0 (7X37/21)	446	.750	8	50	W53378O54-088

XXX Insert code for spool length. Choose code from available put ups column.

* Hypalon is a registered trademark of E.I. DuPont de Nemours.
† Exar is a registered trademark of Champlain Cable Corporation.

COLOR CODE CHART - All colors not available in all putups

2 = RED (RED) 4 = YELLOW (YEL) 5 = GREEN (GRN) 7 = VIOLET (VIO) 8 = GRAY (GRY) 9 = WHITE (WHT)
10 = BLACK (BLK) 13 = DARK BLUE (BLU) 125 = WHITE W/RED TRACER (WTRD) 132 = WHITE W/BLACK TRACER (WTBK)

CONNECTION INSULATION - LEAD WIRE

EPDM

EPDM is a high temperature flexible lead wire. It has a tough insulation resistant to abrasion and cut through. Suitable for some Class H applications. Fair to poor oil resistance. UL listing 3374 & CSA listing CL-1503.



600 VOLT CLASS F (150°C)



AWG (STRANDING)	AMP ** CAPACITY	NOMINAL O.D. (IN.)	AVAILABLE COLORS	AVAILABLE PUT UPS (FT.)	PART NUMBER
18 (16X30)	24	.141	10	500	W53396V18-000
16 (26X30)	30	.154	10	500	W53396V16-000
14 (41X30)	40	.169	10	250	W53396V14-000
12 (65X30)	50	.193	10	250	W53396V12-000
10 (105X30)	70	.253	10	250	W53396V10-000
8 (7X19/29)	95	.336	10	250	W35312O08-000
6 (7X19/27)	130	.378	10	100	W35311O06-000
4 (7X19/25)	175	.431	10	100	W35311O04-000
2 (7X19/23)	230	.500	10	100	W35311O02-000
1 (7X37/25)	270	.565	10	100	W35308O01-000
1/0 (7X37/24)	310	.610	10	50	W35314O51-000
2/0 (7X37/23)	360	.661	10	50	W35314O52-000
3/0 (7X37/22)	415	.716	10	50	W35314O53-000
4/0 (7X37/21)	490	.781	10	50	W35308O54-000

EPDM

Never before have you had the benefits of Hypalon and Silicone wrapped into one insulation. Recommended for use in Class F and some Class H applications. Exceptional cut through and abrasion resistance. UL listing 3374.



600 VOLT CLASS F (150°C)



AWG (STRANDING)	AMP ** CAPACITY	NOMINAL O.D. (IN.)	AVAILABLE COLORS	AVAILABLE PUT UPS (FT.)	PART NUMBER
18 (16X30)	24	.142	2,4,5,9,10,13	500	MLW-37118-***-500
			2,4,9,10,13	5000	MLW-37118-***-5000
16 (26X30)	31	.155	2,4,5,9,10,13	500	MLW-37116-***-500
			10	4000,5000	MLW-37116-BLK-XXX
14 (41X30)	46	.170	2,10	500,4000	MLW-37114-***-XXX
			10	5000	MLW-37114-BLK-5000
12 (65X30)	60	.190	2,10	500	MLW-37112-***-500
			10	3000,5000	MLW-37112-BLK-XXX
10 (65X28)	80	.240	10	500,2000,5000	MLW-37110-BLK-XXX
8 (84X27)	106	.327	10	250,500,2500	MLW-37108-BLK-XXX
6 (84X25)	155	.383	10	100,250,500,2500	MLW-37106-BLK-XXX
4 (105X24)	190	.432	10	100,250,500,1000	MLW-37104-BLK-XXX
3 (133X24)	214	.453	10	100,250	MLW-37103-BLK-XXX
2 (163X24)	255	.494	10	100,250,1000	MLW-37102-BLK-XXX
1 (210X24)	293	.583	10	100,250,1000	MLW-37101-BLK-XXX
1/0 (262X24)	339	.633	10	50,100,250,500	MLW-37190-BLK-XXX
2/0 (504X26)	390	.698	10	50,100,250,500	MLW-37100-BLK-XXX
3/0 (630X26)	451	.758	10	50,250,500	MLW-37130-BLK-XXX
4/0 (805X26)	529	.869	10	50,250,500	MLW-37140-BLK-XXX

** Maximum values for single conductor in free air at 30°C. *** Insert letter code for color.
XXX Insert code for spool length.

COLOR CODE CHART - All colors not available in all putups

2 = RED (RED) 4 = YELLOW (YEL) 5 = GREEN (GRN) 7 = VIOLET (VIO) 8 = GRAY (GRY) 9 = WHITE (WHT)
10 = BLACK (BLK) 13 = DARK BLUE (BLU) 125 = WHITE W/RED TRACER (WTRD) 132 = WHITE W/BLACK TRACER (WTBK)

CONNECTION INSULATION - LEAD WIRE



EPDM 7500 VOLT CLASS F (150°C)

EPDM is naturally corona resistant and more heat resistant than other rubber compounds and is able to take the long bake cycles associated with the larger jobs. EPDM has superior weather resistance and low temperature flexibility. EPDM is used in many high voltage applications. UL style 3499.

AWG (STRANDING)	AMP ** CAPACITY	NOMINAL O.D. (IN.)	AVAILABLE COLORS	AVAILABLE PUT UPS	PART NUMBER
8 (84X27)	106	.423	10	50,500,1000	MLW-37508-BLK-XXX
6 (84X25)	155	.470	10	50,500,1000	MLW-37506-BLK-XXX
4 (105X24)	190	.526	10	50,500,1000	MLW-37504-BLK-XXX
2 (163X24)	255	.581	10	50,500,1000	MLW-37502-BLK-XXX
1 (210X24)	293	.638	10	50,500	MLW-37501-BLK-XXX
1/0 (262X24)	339	.688	10	50,250,500	MLW-37590-BLK-XXX
2/0 (504X26)	390	.753	10	50,250,500	MLW-37500-BLK-XXX
3/0 (630X26)	451	.813	10	50,250	MLW-37530-BLK-XXX
4/0 (805X26)	529	.929	10	50,250,500	MLW-37540-BLK-XXX

** Maximum values for single conductor in free air @ 30°C. XXX Insert code for spool length. Choose code from available put ups column.

EPDM 7500 VOLT CLASS F (150°C)



EPDM is naturally corona resistant and more heat resistant than other rubber compounds and is able to take the long bake cycles associated with the larger jobs. EPDM has superior weather resistance and low temperature flexibility. EPDM is used in many high voltage applications. UL style 3499.

AWG (STRANDING)	AMP ** CAPACITY	NOMINAL O.D. (IN.)	AVAILABLE COLORS	AVAILABLE PUT UPS	PART NUMBER
8 (7x12/27)	106	.431	10	50	W35313O08-000
6 (7x12/25)	155	.473	10	50	W35313O06-000
4 (7x19/25)	190	.526	10	50	W35313O04-000
2 (7x19/23)	255	.594	10	50	W35313O02-000
1 (7x37/25)	293	.630	10	50	W35313O01-000
1/0 (7x37/24)	339	.684	10	50	W35313O51-000
2/0 (7x37/23)	390	.725	10	50	W35313O52-000
3/0 (7x37/22)	457	.791	10	50	W35313O53-000
4/0 (7X37/21)	529	.849	10	50	W35313O54-000

XXX Insert code for spool length. Choose code from available put ups column.



EXAR 3575 7500 VOLT CLASS F (150°C)



EXAR 3575 is a unique composite insulation consisting of a semi-conductive insulation covered with a layer of standard EXAR 150. Coupled with flexible stranding and smaller outside diameters, it offers excellent flexibility and outstanding processability. UL style 3575.

AWG (STRANDING)	AMP ** CAPACITY	NOMINAL O.D. (IN.)	AVAILABLE COLORS	AVAILABLE PUT UPS	PART NUMBER
8 (168X30)	79	.275	10	50,250,500	XR3575-8-BLK-XXX
6 (259X30)	110	.341	10	50,250,500	XR3575-6-BLK-XXX
4 (413X30)	150	.402	10	50,250,500	XR3575-4-BLK-XXX
2 (665X30)	195	.466	10	50,250	XR3575-2-BLK-XXX
1 (836X30)	225	.541	10	50,250	XR3575-1-BLK-XXX
1/0 (1045X30)	260	.591	10	50,250	XR3575-1/0-BLK-XXX
2/0 (1330X30)	300	.651	10	50,250	XR3575-2/0-BLK-XXX
3/0 (1672X30)	345	.711	10	50,250	XR3575-3/0-BLK-XXX
4/0 (2109X30)	400	.786	10	50,250	XR3575-4/0-BLK-XXX

XXX Insert code for spool length. Choose code from available put ups column.

COLOR CODE CHART - All colors not available in all putups

2 = RED (RED) 4 = YELLOW (YEL) 5 = GREEN (GRN) 7 = VIOLET (VIO) 8 = GRAY (GRY) 9 = WHITE (WHT)
 10 = BLACK (BLK) 13 = DARK BLUE (BLU) 125 = WHITE W/RED TRACER (WTRD) 132 = WHITE W/BLACK TRACER (WTBK)

CONNECTION INSULATION - LEAD WIRE



HYPALON* 5000 VOLT CLASS A (105°C)

Long time industry standard suitable for use in Class B systems. Excellent heat resistance, color stability, and electrical properties. Good flexibility. UL & CSA listed. Rated 5000 volt.

AWG (STRANDING)	AMP** CAPACITY	NOMINAL O.D. (IN.)	AVAILABLE COLORS	AVAILABLE PUT UPS (FT.)	PART NUMBER
8 (84X27)	90	.480	10	50,500	MLW-36108-BLK-XXX
6 (84X25)	121	.532	10	50,500	MLW-36106-BLK-XXX
4 (105X24)	160	.588	10	50,500	MLW-36104-BLK-XXX
2 (163X24)	215	.643	10	50,500	MLW-36102-BLK-XXX
1 (210X24)	247	.700	10	50,250	MLW-36101-BLK-XXX
1/0 (262X24)	286	.750	10	50,500	MLW-36190-BLK-XXX
2/0 (504X26)	329	.815	10	50	MLW-36100-BLK-XXX
4/0 (805X26)	446	.979	10	50,250	MLW-36140-BLK-XXX

XXX Insert code for spool length. Choose code from available put ups column.



XL-DUR 600 VOLT CLASS A (125°C) UL & CSA

This insulation is cross-linked polyethylene applied in a single extrusion. This construction has excellent thermal aging characteristics, moisture resistance and solvent resistance. It provides an economic alternate to HYPALON where extreme flexibility is not required. Recommended for Class B motor leads.

AWG (STRANDING)	AMP** CAPACITY	NOMINAL O.D. (IN.)	AVAILABLE COLORS	AVAILABLE PUT UPS (FT.)	PART NUMBER
22 (7X30)	12	.093	2,5,9,10	5000	MLW-35622-***-XXX
20 (10X30)	15	.102	10	500	MLW-35620-***-XXX
			1,2,4,6,9,10	5000	MLW-35620-***-XXX
18 (16X30)	22	.110	2,4,5,10,13	500	MLW-35618-***-XXX
			1,2,3,4,5,7-10,13	5000	MLW-35618-***-XXX
16 (26X30)	28	.123	2,4,5,9,10	500	MLW-35616-***-XXX
			1,2,3,4,5,8,9,10	5000	MLW-35616-***-XXX
14 (41X30)	42	.138	10	500	MLW-35614-***-XXX
			2,3,4,5,9,10	5000	MLW-35614-***-XXX
12 (65X30)	55	.153	10	500	MLW-35612-***-XXX
			9,10	3000	MLW-35612-***-XXX
10 (65X28)	72	.177	9,10	2000	MLW-35610-***-XXX
8 (133X29)	97	.263	9,10	2000	MLW-35608-***-XXX
6 (133X27)	131	.333	9,10	2000	MLW-35606-***-XXX

***Insert code for color. XXX Insert code for spool length. Choose code from available put ups column.



PVC 600 VOLT CLASS A (105°C) UL & CSA

Vinyl plastic insulation is fast stripping, resists oil, solvents and ozone. The colors are bright and remain distinct after processing. Applications include motors, transformers, fluorescent ballast and fixtures, switchboards, panels, controls, rectifiers and electronic circuits. Meets VW1 vertical flame test.

AWG (STRANDING)	AMP** CAPACITY	NOMINAL O.D. (IN.)	AVAILABLE COLORS	AVAILABLE PUT UPS (FT.)	PART NUMBER
22 (7X30)	11	.093	2,4,5,9,10,13	1000,5000	MLW-30622-***-XXXX
20 (10X30)	14	.100	1-5,7,9,10,13	1000,4000	MLW-30620-***-XXXX
18 (16X30)	20	.110	1-5,8-10,13	500,1000,4000	MLW-30618-***-XXX
16 (26X30)	26	.123	1-5,9,10,13	500,1000,4000	MLW-30616-***-XXX
14 (41X30)	39	.138	2-5,9,10,13	500,5000	MLW-30614-***-XXX
12 (65X30)	51	.158	9,10	500,2500	MLW-30612-***-XXX
10 (65X28)	67	.177	9,10	250,1000	MLW-30610-***-XXX
8 (84X27)	90	.250	9,10	1000	MLW-30608-***-XXX

***Insert code for color. XXX Insert code for spool length. Choose code from available put ups column.

COLOR CODE CHART - All colors not available in all putups

2 = RED (RED) 4 = YELLOW (YEL) 5 = GREEN (GRN) 7 = VIOLET (VIO) 8 = GRAY (GRY) 9 = WHITE (WHT)
 10 = BLACK (BLK) 13 = DARK BLUE (BLU) 125 = WHITE W/RED TRACER (WTRD) 132 = WHITE W/BLACK TRACER (WTBK)

* Hypalon is a registered trademark of E.I. DuPont de Nemours.

CONNECTION INSULATION - BRAZING & SOLDERING



CANFIELD TECHNOLOGIES solder is made from virgin grade tin and lead. The purer the solder, the better the connection. Electro pure solder has a total contamination level that is a fraction of the industry standards.

50/50 solid core - Melting point 183°-212°C. Economical, general purpose solder with good wetting characteristics.

60/40 solid core - Melting point 183°-188°C. Better wetting characteristics than 50/50 with a lower melting temperature and better joint strength.

60/40 ROSIN core - Time saving cored wire solder. Eliminates the need for other fluxes, 3% activated rosin has excellent oxide removing chemistry which enhances solder speed and joint spread.

TYPE	1/16" DIAMETER		1/8" DIAMETER	
	1 LB.	5 LB.	1 LB.	5 LB.
50/50 Solid	CAN-50-062-1SW	CAN-50-062-5SW	CAN-50-125-1SW	CAN-50-125-5SW
60/40 Solid	CAN-60-062-1SW	CAN-60-062-5SW	CAN-60-125-1SW	CAN-60-125-5SW
60/40 Rosin	CAN-60-062-1RC	CAN-60-062-5RC	CAN-60-125-1RC	CAN-60-125-5RC

SILICONE RUBBER CAPS



Form coil connection can be insulated like the OEM manufacturers do.

These caps are made from virgin 50/60 durometer silicone rubber. Dimensions are 7/8" long. Opening is 5/8" tapering to 3/8". Use Dow Corning 738 electrical grade sealant to hold the cap in place.

PART NUMBER	TSRC-C5
--------------------	---------



CANFIELD TECHNOLOGIES SILVER SOLDER

Silver/tin alloys are an excellent choice for electrical and electronic connections. Melting point of 221°C, excellent wetting characteristics and high bond strength. Reduces chance of dripping and sharp points during soldering.

SILVER CONTENT	DIA. (IN.)	PART NUMBER
4%	1/16	CAN-96-062-1SW
	1/8	CAN-96-125-1SW
5%	1/16	CAN-95-062-1SW
	1/8	CAN-95-125-1SW

BURNLEY SOLDERING SOLUTIONS



Over 80 years of experience in manufacturing has developed a soldering flux that is always sure and ready to use. Burnley soldering paste meets federal spec O.F. 506C Type 1 Form A.

SOLDERING PASTE		SOLDER SALTS	
SIZE	PART NUMBER	SIZE	PART NUMBER
2 Oz.	BSP-101	8 Oz.	BSS-8OZ
4 Oz.	BSP-102	1 Lb.	BSS-1LB
8 Oz.	BSP-103		
1 Lb.	BSP-104		

BRAZING ROD SIL PHOS

Phos copper with silver added. The higher the silver content, the better it's ability to fill gaps. Especially useful for joining shaped wire. 18 inch lengths. Sold by the pound.

SILVER CONTENT	DIA. (IN.)	PART NUMBER
2%	1/16	MB-2-1/16
	1/8	MB-2-1/8
5%	1/16	MB-5-1/16
	1/8	MB-5-1/8
15%	1/16	MB-15-1/16
	1/8	MB-15-1/8

BRAZING ROD PHOS COPPER

An economical, medium temperature range brazing alloy. Self fluxing on copper and ideally suited for electrical connections. Recommended for use when good fit up can be maintained. Sold by the pound.

18 INCH LENGTH		
DIA. (IN.)	PCS/LB.	PART NUMBER
1/16	56	MB-0-1/16
1/8	16	MB-0-1/8
36 INCH LENGTH		
DIA. (IN.)	PCS/LB.	PART NUMBER
1/16	28	SPH-116
1/8	8	SPH-18

STATOR CLIPS

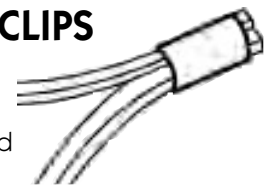

A convenient method of holding shaped wire together while making the connection. Simply crimp the sleeve over the wires to be joined and fill the connection with solder or PHOS copper.

I.D. (IN.)	O.D. (IN.)	LENGTH (IN.)	PART NUMBER
1/4	.290	1/2	TSC-1/4
3/8	.415	1/2	TSC-3/8
1/2	.540	1/2	TSC-1/2
5/8	.665	1/2	TSC-5/8
3/4	.790	1/2	TSC-3/4
7/8	.915	1/2	TSC-7/8

CONNECTION INSULATION - TERMINALS



1.) NON-INSULATED RING TONGUE TERMINALS

Versakrimp braided barrel design provides a strong crimp that will not pull out under adverse conditions.

2.) INSULATED RING TONGUE TERMINALS

Color code PVC insulation is affixed permanently to the barrel. 22 - 10 AWG are butted seam design, 8 - 4/0 are braided barrel design. Funnel entrance eliminates wire strand "hang-up" on insertion.



3.) NON-INSULATED EYELET STYLE TERMINALS

Seamless barrel design is tin plated to guard against corrosion. Flared barrel entry makes it easy to insert the wire, and can be crimped or soldered.

4.) NON-INSULATED BUTT SPLICES

Seamless barrel design offers the ultimate in wire holding capacity.

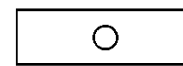

WIRE SIZE	STUD SIZE	QTY/ BOX	NON-INSULATED RING TONGUE LENGTH (IN.)	PART NUMBER	INSULATED RING TONGUE LENGTH (IN.)	PART NUMBER	NON-INSULATED EYELET STYLE LENGTH (IN.)	PART NUMBER	NON-INSULATED BUTT SPLICES LENGTH (IN.)	PART NUMBER
22/18	8	100	.671	ETC-AA-321-08	.896	ETC-AA-221-08X			.675	ETC-AS-345
	10	100	.671	ETC-AA-321-10	.896	ETC-AA-221-10X				
16/14	8	100	.640	ETC-BB-337-08	.880	ETC-BB-237-08X			.675	ETC-BS-331
	10	100	.696	ETC-BB-339-10	.936	ETC-BB-239-10X				
	1/4	100	.837	ETC-BB-325-14	1.091	ETC-C-228-10X			.827	ETC-CS-346
	1/4	100	.952	ETC-C-330-14	1.258	ETC-C-230-14X				
	5/16	100	.952	ETC-C-330-56	1.258	ETC-C-230-56X				
	3/8	100	1.056	ETC-C-340-38	1.399	ETC-D-650-10X	1.200	ETC-BCL-810-PL	.864	ETC-D-354
	1/4	100	.984	ETC-D-350-14	1.399	ETC-D-650-14X	1.200	ETC-BCL-814-PL		
	5/16	100	1.106	ETC-D-351-56	1.521	ETC-D-651-56X	1.305	ETC-BCL-8516-PL		
	3/8	100	1.106	ETC-D-351-38	1.521	ETC-D-651-38X	1.305	ETC-BCL-838-PL		
	6	1/4	50	1.268	ETC-E-357-14	1.703	ETC-E-657-14X	1.270	ETC-BCL-614-PL	1.045
4	5/16	50	1.268	ETC-E-357-56	1.703	ETC-E-657-56X	1.410	ETC-BCL-6516-PL		
	3/8	50	1.268	ETC-E-357-38	1.703	ETC-E-657-38X	1.410	ETC-BCL-638-PL		
	1/4	50	1.357	ETC-F-366-14	1.928	ETC-F-666-14X	1.500	ETC-BCL-414-PL	1.155	ETC-F-364
2	5/16	50	1.357	ETC-F-366-56	1.928	ETC-F-666-56X	1.530	ETC-BCL-4516-PL		
	3/8	50	1.357	ETC-F-366-38	1.928	ETC-F-666-38X	1.530	ETC-BCL-438-PL		
	1/2	25	1.700	ETC-G-374-56	2.303	ETC-G-674-56X	1.620	ETC-BCL-2516-PL	1.280	ETC-G-372
1/0	3/8	25	1.700	ETC-G-374-38	2.303	ETC-G-674-38X	1.620	ETC-BCL-238-PL		
	1/2	25	1.700	ETC-G-374-12	2.303	ETC-G-674-12X	1.750	ETC-BCL-212-PL		
	5/16	25	1.920	ETC-H-381-56	2.628	ETC-H-681-56X	1.830	ETC-BCL-10516-PL	1.440	ETC-H-383
	3/8	25	1.920	ETC-H-381-38	2.628	ETC-H-681-38X	1.830	ETC-BCL-1038-PL		
2/0	1/2	25	1.951	ETC-H-380-12	2.659	ETC-H-680-12X	1.830	ETC-BCL-1012-PL		
	5/16	25	2.019	ETC-J-385-56	2.727	ETC-J-685-56X	2.062	ETC-BCL-20516-PL	1.440	ETC-J-388
	3/8	25	2.019	ETC-J-385-38	2.727	ETC-J-685-38X	2.062	ETC-BCL-2038-PL		
3/0	1/2	25	2.019	ETC-J-385-12	2.727	ETC-J-685-12X	2.062	ETC-BCL-2012-PL		
	5/16	25	2.154	ETC-K-390-56	3.008	ETC-K-690-56X	2.160	ETC-BCL-30516-PL	1.540	ETC-K-393
	3/8	25	2.154	ETC-K-390-38	3.008	ETC-K-690-38X	2.160	ETC-BCL-3038-PL		
4/0	1/2	25	2.154	ETC-K-390-12	3.008	ETC-K-690-12X	2.160	ETC-BCL-3012-PL		
	3/8	25	2.215	ETC-L-395-38	3.069		2.350	ETC-BCL-4038-PL	1.540	ETC-L-378
	1/2	25	2.215	ETC-L-395-12	3.069		2.350	ETC-BCL-4012-PL		

SCOTCHLOK[®] WIRE NUTS

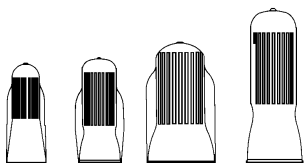

Premium 3M wire nuts feature a "live spring" which assures a tight grip even on small wire combinations. 105°C, 600 volt rated.

AWG *	COLOR	PART NUMBER
2 - #12	YELLOW	Y-20041
3 - #10	RED	R-20058
2 - #8	GRAY	G-21346
2 - #6	BLUE	B-20066

*Maximum Combination Allowed

‡ Scotchlok is a registered trademark of 3M.

UL file E23438
CSA file LR15503.
100/box except blue, which are 50/box.

RIGHT ANGLE FLAG TERMINALS



These non-insulated terminals are perfect for use on capacitors, switches and terminal boards. Right angle design allows for clearance in tight applications.

AWG	TAB SIZE (IN.)	PART NUMBER
22-18	.187 X .020	ETC-AA-1147
22-18	.250 X .032	ETC-AA-1158
16-14	.187 X .020	ETC-BB-1148
16-14	.250 X .032	ETC-BB-1159
12-10	.250 X .032	MU10-250

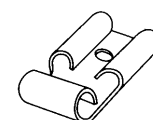

TIE CORDS - SECURING THE WINDING

POLYESTER TIE TAPE CLASS F (160°C)

Western Filament's DHS series tie cord is made from a continuous filament braided DACRON* yarn. Supplied with CL coating to help prevent snagging fraying or unraveling. Heat shrinkable to snug up the winding. Shrinks 10 - 11% at 325°F/1 hour.



WIDTH (IN.)	THICKNESS (IN.)	NOM. BREAK (LBS.)	LENGTH (YDS.)	PART NUMBER
.062	.010	45	500	DHS-4CL
.080	.010	60	500	DHS-3CL
.125	.010	100	250	DHS-2CL
.225	.015	190	250	DHS-1CL
.375	.020	410	250	DHS-0CL
.500	.025	700	83.3	DHS-00CL

NOMEX® TIE TAPE & CORD CLASS H (200°C)

Dupont arimid fibers are braided into a smooth flat tape or cord which is stable at high temperatures and self extinguishing. Suitable for use on hermetic applications.



NOMEX® CORD

DIAMETER (IN.)	NOMINAL BREAK (LBS.)	LENGTH (YDS.)	PART NUMBER
.026	40	1117	NRT-3CL
.045	70	490	NRT-2CL
.055	100	325	NRT-1CL

NOMEX® TAPE

WIDTH (IN.)	THICKNESS (IN.)	NOM. BREAK (LBS.)	LENGTH (YDS.)	PART NUMBER
.090	.012	40	500	NFB-3CL
.125	.014	70	250	NFB-2CL
.225	.016	90	250	NFB-1CL



WAXED NYLON TIE TAPE CLASS A (93°C)



A low cost lacing material. Impregnated with 30 - 35% fungicidal wax. Non-braided flat nylon tape. Withstands temperatures up to 93°C.

NOM. WIDTH (IN.)	NOM. THICK (IN.)	NOM. BREAK	LENGTH (FT.)	PART NUMBER
.062	.013	30	135	GC-6
.070	.016	50	90	GC-9
.092	.019"	70	60	GC-12

STATOR TY CORD CLASS F (155°C)

A B-Stage roped and resin impregnated Glass cord with 35% resin content.



PART NUMBER B032245-350

FIBERGLASS TIE CORD CLASS H (180°C)

A twisted and cabled fiberglass cord. Made from 100% electrical grade fiberglass yarn. This cord has an approximate 4% neoprene coating to improve handling and knot retention properties. Meets mil spec MIL-Y-1140. 2 lb. spools.



DIA. (IN.)	NOM. BREAK	YARD/ (LB.)	PART NUMBER
.011	11	3240	EC-9-1N
.033	51	638	EC-9-2N
.040	77	387	EC-9-3N
.062	146	193	EC-9-4N
.085	250	98	EC-9-5N
.094	288	84	EC-9-6N
.110	355	61	EC-9-7N
.128	461	42	EC-9-8N
.165	605	27	EC-9-10N

VICTOR WAXED LINEN TIE CORD CLASS A (105°C)



This is the standard lacing cord for the electrical and electronic industry with a proven record for performance and quality. Treated with a microcrystalline wax to resist mildew and improve knot retention. High tensile strength. Sizes 12, 8, and 6 meets mil spec MIL-T-713 Type N.

DIA. (IN.)	NOM. BREAK	YARDS/ TUBE	PART NUMBER
.036	22	850	VLC-4
.044	32	600	VLC-6
.051	48	450	VLC-8
.054	60	400	VLC-9
.063	70	300	VLC-12

MOTOR-TY CORD CLASS F (155°C)



A hand-tying cord designed to upgrade and replace Class A cotton/linen materials. A continuous filament, high tenacity polyester yarn, twisted into a smooth concentric cord and impregnated with microcrystalline fungicidal wax. Provides superior temperature range, greater strength, lighter weight and lower costs than natural fibers.

DIA. (IN.)	NOM. BREAK	YARDS/ ROLL	PART NUMBER
.036	70	600	WF-64
.050	85	400	WF-96
.062	115	300	WF-128

WAXED LINEN TIE CORD CLASS A (105°C)

Economical linen tie cord treated with a microcrystalline wax for good knot retention. Features high tensile strength and mildew resistance.



DIA. (IN.)	NOM. BREAK	YARDS/ TUBE	PART NUMBER
.046	38	600	WLT-6/4-CORD
.056	58	400	WLT-9/6-CORD
.064	75	300	WLT-12/8-CORD



* Dacron and Nomex are registered trademarks of E.I. DuPont de Nemours.

BLOCKING - SECURING THE WINDING

One of the major causes of failure in the winding of an electric motor is abrasion caused by vibration and flexing. By providing a solid foundation for the winding, vibration can be reduced to a minimum. Using a felt blocking between the coils is an effective method of supporting the coils so they will not rub against each other. Tying the end turns to a surge ring rope will help reduce the flexing that occurs during operation. These steps alone will not prevent a winding from failure but they do make up part of a quality insulation system.

DRY SURGE RING ROPE CLASS F (155°C)



A stranded KEVLAR* core gives this untreated surge rope tremendous strength for heavy duty applications. Covered with polyester yarn to help keep the KEVLAR* strands together. Ideal for VPI applications.

DIA. (IN.)	STRENGTH	PART NUMBER
3/8	1500 LBS	WF-EP1-375
5/8	3500 LBS	WF-EP1-625
1	5700 LBS	WF-EP1-100

DRY FELT BLOCKING CLASS F (155°C)

Untreated polyester fiber felts for use as blocking between end turns and as a filler in slots or other applications. Available in low density and high density. High density is approximately twice as dense as the low density product. For use in VPI and static dip applications. Low density rolls are 12 feet long, high density rolls are 10 yards long.



LOW DENSITY

WIDTH (IN.)	.050 THICK	.085 THICK	.125 THICK	.250 THICK	.400 THICK
3/4	DFB-U201-3/4	DFB-U203-3/4	DFB-U206-3/4	DFB-U216-3/4	DFB-U230-3/4
1	DFB-U201-1	DFB-U203-1	DFB-U206-1	DFB-U216-1	DFB-U230-1
2	DFB-U201-2	DFB-U203-2	DFB-U206-2	DFB-U216-2	DFB-U230-2
3	DFB-U201-3	DFB-U203-3	DFB-U206-3	DFB-U216-3	DFB-U230-3

HIGH DENSITY

	3/4" WIDTH	1" WIDTH	2" WIDTH	3" WIDTH
1/8" THICK	DFB-1/8-3/4	DFB-1/8-1	DFB-1/8-2	DFB-1/8-3

B-STAGE TREATED FELT BLOCKING CLASS F (155°C)

Polyester fiber felts saturated with a B-stage epoxy resin. Due to the high 85% resin content, the resin flows readily under light pressure to form a dense structure with high dielectric strength. Soft and pliable in uncured form they will conform to almost any shape. When cured with heat they will become hard and rigid and bond to almost any surface. Typical applications include blocking end turns, sealing coil connections, and slot filling. Typical cure cycles are 8 - 16 hours at 135°C, 6 - 8 hours at 150°C, or 2 - 3 hours at 180°C. Shelf life is 12 months at 40°F. Rolls are 12 feet long.



WIDTH (IN.)	.050 THICK	.085 THICK	.125 THICK	.250 THICK	.400 THICK
3/4	DFB-B201-3/4	DFB-B203-3/4	DFB-B206-3/4	DFB-B216-3/4	DFB-B230-3/4
1	DFB-B201-1	DFB-B203-1	DFB-B206-1	DFB-B216-1	DFB-B230-1
2	DFB-B201-2	DFB-B203-2	DFB-B206-2	DFB-B216-2	DFB-B230-2
3	DFB-B201-3	DFB-B203-3	DFB-B206-3	DFB-B216-3	DFB-B230-3

NOMEX* FELT BLOCKING CLASS R (220°C)

Untreated NOMEX* cloth is perfect for Class H blocking. Temperature rating 315°C. NOMEX* cloth exhibits excellent abrasion resistance. Available in 1/16" thickness Stitchbond on 100 foot rolls or 1/8" thickness Plain Needlefelt on 50 foot rolls.



WIDTH (IN.)	NEEDLEFELT 1/8" PART NUMBER	STITCHBOND 1/16" PART NUMBER
1	APN-1-IN	AFN-1-IN
2	APN-2-IN	AFN-2-IN
3	APN-3-IN	AFN-3-IN
4	APN-4-IN	AFN-4-IN
5	APN-5-IN	AFN-5-IN
6	APN-6-IN	AFN-6-IN

DRY SURGE RING ROPE CLASS H (180°C)



Lectromat offers a dry surge ring rope that is untreated to be used in VPI and dip applications where B-stage resin is not required. It is a bundle of glass fiber rovings encased in a braided glass sleeving.

DIA. (IN.)	LENGTH (FT.)	PART NUMBER
3/8	100	LG14U-3/8-100FT
1/2	50	LG14U-1/2-50FT
5/8	50	LG14U-5/8-50FT
3/4	50	LG14U-3/4-50FT
1	50	LG14U-1IN-50FT

B-STAGE SURGE ROPE CLASS R (220°C)



Fibertek surge rope is constructed of a core of glass yarns impregnated with a thermosetting modified polyester resin. This B-stage core is over-braided with a polyester fiber that is untreated for easy handling. 35% resin content rated at 220°C.



DIA. (IN.)	LENGTH	PART NUMBER
1/4	100 FT	SRR14-1/4X100FT
3/8	100 FT	SRR38-3/8X100FT
1/2	50 FT	SRR12-1/2X50FT
5/8	50 FT	SRR58-5/8X50FT
3/4	50 FT	SRR34-3/4X50FT
7/8	50 FT	SRR78-7/8X50FT

* Kevlar and Nomex are registered trademarks of E.I. DuPont de Nemours.

BANDING - SECURING THE WINDING

RES-I-GLAS⁺⁺ BANDING TAPE



FIBERTEK RES-I-GLAS⁺⁺ banding has successively replaced steel banding wires in numerous applications, and is the #1 choice over competitive tapes. RES-I-GLAS⁺⁺ tape is constructed from high tensile electrical grade glass yarns, laid parallel to each other utilizing the full tensile strength of the glass. Ultimate tensile strength 240,000 PSI. Mil spec MIL-I-24178. Recommended banding tension is 400 lbs. per inch of width.

TYPE F CLASS H (220°C)

27% resin content. Can be applied either hot or cold. Exhibits excellent resin flow characteristics.

TYPE G CLASS F (155°C)

27% resin content. Should be applied to hot armatures.

TYPE R CLASS F (155°C)

32% resin content. Can be applied hot or cold. High resin content produces smooth surface coating.

TYPE M CLASS H (220°C)

27% resin content. For use in applications where excessive heat and moisture are expected.

COIL BAND

FIBERTEK'S Coil band tapes are non-woven, uni-directional, parallel strands of cotton yarns bonded with an appropriate binder. They combine high tensile with low elongation and high shear strength to provide space saving properties. The water soluble binder is inert in oil and pyranol. Thickness is .007" except for type O which is .010" thick.



WIDTH (IN.)	TENSILE (LBS.)	LENGTH (YDS.)	PART NUMBER
3/8	45	100	FCB-38100B
3/8	45	1000	FCB-381000S
1/2	60	500	FCB-12500S
5/8	75	500	FCB-58500S
3/4	90	100	FCB-34100B
3/4	90	500	FCB-341500S
		TYPE O	
3/8	80	500	FCB-38500SO
3/8	80	1000	FCB-381000SO

RES-I-STRAINT CLASS H (180°C)

FIBERTEK'S tadpole edging tape is a unique design where the bead is impregnated with a B-stage resin and the glass wrap is not treated to provide easy handling. The bead should be the same diameter as the thickness of the band. Use a third restraint in the center of wide bands to provide stress relief. The glass wrap is .007" thick. Supplied on 100 yard spools.

BEAD DIA. (IN.)	WIDTH (IN.)	PART NUMBER
3/32	1	FRS-321
5/32	1	FRS-521
3/16	1-1/2	FRS-361.5
3/16	3	FRS-363



RES-I-BAND

FIBERTEK'S banding film has a special release agent that allows it to be only .001" thick, resulting in up to 50% material costs. The film has a consistent 5% shrink factor that improves resin flow in the banding tape and gives the band a smooth finish. The special release agent helps in removal. 200 yard rolls.

WIDTH (IN.)	PART NUMBER
3/4	FRB-0075
1	FRB-0100
1-1/2	FRB-0150
2	FRB-0200
3	FRB-0300
4	FRB-0400

RELEASE FILMS

HI SHRINK TAPE

This tape will shrink approx. 20% at 300°F and exerts approximately 2500 lsb. of force for each layer of tape applied. Shrink temperature range is 200° to 400°F, and shrinks in seconds when heated. Available in two thicknesses .002" thick are 100 yard rolls and .005" thick are 40 yard rolls.

WIDTH (IN.)	THICK (IN.)	PART NUMBER
3/8	.002	HST-002-3/8IN
3/4	.002	HST-002-3/4IN
1	.002	HST-002-1IN
2	.002	HST-002-2IN
1/2	.005	HST-005-1/2IN
1	.005	HST-005-1IN
1-1/4	.005	HST-005-1-1/4IN

TYPE F RES-I-GLAS

WIDTH (IN.)	LENGTH (YDS.)	PART NUMBER
1/4	250	FRG-0222F-250
3/8	250	FRG-0322F-250
1/2	250	FRG-0422F-250
3/4	100, 200	FRG-0622F-***
1	100, 200	FRG-0822F-***
1-1/2	100, 200	FRG-1222F-***
2	100, 200	FRG-1622F-***

TYPE G RES-I-GLAS

WIDTH (IN.)	LENGTH (YDS.)	PART NUMBER
1/4	250	FRG-0222G-250
3/8	250	FRG-0322G-250
1/2	250	FRG-0422G-250
3/4	100, 200	FRG-0622G-***
1	100, 200	FRG-0822G-***
1-1/2	100, 200	FRG-1222G-***
2	100, 200	FRG-1622G-***

TYPE R RES-I-GLAS

WIDTH (IN.)	LENGTH (YDS.)	PART NUMBER
1/4	250	FRG-0222R-250
3/8	250	FRG-0322R-250
1/2	250	FRG-0422R-250
3/4	100, 200	FRG-0622R-***
1	100, 200	FRG-0822R-***
1-1/2	100, 200	FRG-1222R-***
2	100, 200	FRG-1622R-***
3	100, 200	FRG-2422R-***

TYPE M RES-I-GLAS

WIDTH (IN.)	LENGTH (YDS.)	PART NUMBER
1/4	250	FRG-0222M-250
3/8	250	FRG-0322M-250
1/2	250	FRG-0422M-250
3/4	100, 200	FRG-0622M-***
1	100, 200	FRG-0822M-***
1-1/2	100, 200	FRG-1222M-***
2	100, 200	FRG-1622M-***

HI SHRINK TAPE CLASS B (130°C)



SP-632 is a heat shrinkable tape which cures at a low temperature, thus preventing secondary shrinkage of the film. It is solvent resistant. This 2 mil tape will shrink approximately 30% at 150°C. Supplied on 72 yard or 360 yard rolls.

WIDTH (IN.)	LENGTH (YDS.)	PART NUMBER
3/4	72	PPI-SP632-3/4-72
3/4	360	PPI-SP632-3/4-360
1	72	PPI-SP632-1-72
1	360	PPI-SP632-1-360
1-1/4	72	PPI-SP632-1-1/4-72
1-1/4	360	PPI-SP632-1-1/4-360
2	72	PPI-SP632-2-72
2	360	PPI-SP632-2-360

FINAL INSULATION - MASKING COMPOUNDS & GREASES

MASKING TIP

By using a release agent or masking compound, clean up time can be greatly reduced. The varnish will be much easier to remove from surfaces that you do not want the varnish to adhere to, ex.: threaded holes, end bell fits, etc.

SPRAYON SPRAY VARNISH RELEASE AGENT



Spray onto the surface that you don't want varnish to adhere to, it dries quickly. Once the dip and bake process has been completed, the coating can be easily removed. Dry Film P.T.F.E. with Krytox. Exceptional anti-stick properties resist transferring to finished parts. Multiple releases per application.



CONTAINER	PART NUMBER
16 oz.	SPN-811

YELLOW MASKING COMPOUND



The bright yellow color is highly visible under varnishes. Apply with a brush or knife to approx. a 5-10 mil thickness. Brush or apply in one direction, avoid back and forth strokes. A good rule of thumb is to obscure the surface being coated. Allow to dry 30 minutes before applying varnish treatments. Once the varnish is cured, the coating can be removed by scoring with a wood stick or rod. Clean threads by running a nut or a tap over the threaded areas. Withstands bake temperature up to 392°F for 1-1/4 hours.

CONTAINER	PART NUMBER
1 Gallon	MY-739-1

BLUE MASKING VARNISH



A blue masking varnish that does not adhere to metal surfaces. Forms a quick drying film that can be easily stripped off later. Dries in 5-15 minutes at room temperature. Apply with a disposable brush.

CONTAINER	PART NUMBER
1 Gallon	B-213-1GAL

VERTICAL MASKING COMPOUND



(Thermosetting) Paste-like masking compound for vertical surfaces and irregular surfaces. Can be applied to hot or cold surfaces with a putty knife or caulking gun. The film must be cured at 275°F for 20-30 minutes, before being subjected to varnish, lacquers, solvents.

CONTAINER	PART NUMBER
1 Gallon	CC-1022-1
5 Gallon	CC-1022-5

CLEAR MASKING COMPOUND



This polymer resin prevents adhesion of Dolph solventless resins. This compound is designed to coat metal substrates and mask surfaces from adhesion of solventless polyesters and compounds. Easy to apply by brushing or dipping. Peels off easily leaving metal surfaces clean of varnish. Dries at room temperature in 15-45 minutes, or at 200°F - 2-5 minutes.

CONTAINER	PART NUMBER
1 Gallon	MN-743-1

FAMOUS MASKING COMPOUND



A viscous high temperature-resistant grease designed to facilitate the easy removal of cured varnish from metal surfaces. Highly resistant to solvents and will not contaminate varnishes if it accidentally gets into the dip tank. Famous masking compound does not cure with heat but withstands temperatures up to 500°F. Apply a thick coating of compound to areas that you don't want the varnish to adhere to, varnish application can be done immediately, as there is no cure cycle. After varnish treatment, remove varnish and compound with putty knife or spatula.

CONTAINER	PART NUMBER
10 lbs.	FMC-10
35 lbs.	FMC-35
120 lbs.	FMC-120

GAP FILLING COMPOUND



When mounting field coils on pole pieces, it is important to fill the gaps between the pole piece and field coil to insure good thermal conductivity. These compounds also have mechanical strength due to their high adhesive properties. B-7-302 has a slightly higher viscosity to provide a higher build. Both products exhibit high adhesive properties. Rated up to 150°C temperature rating. Cure cycle is 2-6 hours @ 275°-300°F, depending on depth of material to be cured.

CONTAINER	PART NUMBER
1 Gallon	B-7-300-10LB
5 Gallon	B-7-300-5GAL
55 Gallon	B-7-302-55GAL

FINAL INSULATION - AIR DRY VARNISHES

PURPOSE OF VARNISH AND VARNISHING SYSTEMS.

The primary roles of varnish in an electric motor are

- 1.) **Bonding** the wire together to form a solid mass.
- 2.) **Healing** wire damage due to handling and winding.
- 3.) **Providing** chemical and moisture resistance.
- 4.) **Adding** additional insulation of wires from each other and from metal.
- 5.) **Sealing** the unit to resist moisture, dust and chemical contamination.
- 6.) **Preventing** rust on metal parts.
- 7.) **Filling** the voids in the slots, between layers of insulation, to promote heat transfer.

VPI systems offer the best penetration with the best build of all varnish systems, although VPI systems and processes can prove to be cost prohibitive. When specifying a varnish, bond strength, build, temperature class, and chemical resistance must be taken into consideration. One should look for a varnish that will provide the best bond strength, and provide good chemical and moisture resistance. Dip & bake applications provide an economical means of varnishing motors for most applications. VPI is usually reserved for more stringent applications.

SOLVENT OR SOLVENTLESS VARNISH?

With all the new varnishes out on the market it is tough to know what varnish a shop should use. Consider these points.

- 1.) **Cost** - The initial cost of solventless varnish is higher than solvent based. Monomers in solventless varnish are 100% reactive, so there are minimal VOC's lost during the bake cycle. Solvent based varnishes can lose up to 70% of the mixture during the bake cycle.
- 2.) **Safety** - Because solventless varnishes use monomers as thinners, the flash point is considerably higher than solvent based varnishes. A shop might be able to get a reduction in insurance rates. In addition, the special tanks that are sometimes required with solvent based varnishes are not required. Also there are less VOC's being released into the atmosphere from the oven stack, (better compliance with EPA).
- 3.) **Cure times** - typically the cure times are shorter for solventless varnishes which will offer savings in energy costs.
- 4.) **Bond Strength** - solventless varnishes have higher bond strength than most solvent based varnishes, resulting in less vibration and noise.
- 5.) **Tank Maintenance** - Varnishes may require more tank maintenance if varnish turnover is low.

Before selecting your varnish you need to determine which aspects are most critical to you.

B-277-2 CLASS F (160°C)



A clear air drying varnish for general uses. Exhibits excellent adhesion to steel and copper. Dries to touch in about 5 minutes, complete cure in 1-2 hours. It also has excellent moisture resistance. 2200 volts/mil dielectric strength dry.

CONTAINER	PART NUMBER
1 Gallon	B-277-2-1GAL
5 Gallon	B-277-2-5GAL
55 Gallon	B-277-2-55GAL

AC-43 CLASS F (175°C)



A high temperature modified polyester air dry varnish. AC-43 air dries in about 10 minutes, complete cure in about 1 hour. Can be baked at 300°F for 10-15 minutes to improve it's already excellent moisture and chemical resistance. Clear color. Dielectric strength (dry) 2000 volts/mil (wet) 1200 volts/mil. Build 2-3 mils. Thinner T-200X Xylol.

CONTAINER	PART NUMBER
1 Gallon	AC-43-1
5 Gallon	AC-43-5
55 Gallon	AC-43-55

AC-41 CLASS F (160°C)



A high temperature clear polyurethane air dry varnish. AC-41 air dries in about 10 minutes complete cure in about 1 hour. Can be baked at 300°F for 10-15 minutes to improve it's already excellent moisture and chemical resistance. Clear color. Dielectric strength (dry) 2000 volts/mil (wet) 1200 volts/mil. Build 2.5-3 mils. Thinner T-200X Xylol.

SIZE	PART NUMBER
1 Gallon	AC-41-1
5 Gallon	AC-41-5
55 Gallon	AC-41-55

FINAL INSULATION - SOLVENTLESS EPOXY VARNISHES

CC-1141 CLASS N (205°C)

A modified solventless epoxy resin suitable for use in VPI and dip and bake applications. Low viscosity for excellent penetration, and excellent coating appearance. Exhibits excellent chemical and moisture resistance, recommended for use on hermetic motors. High flash point (>200°C) and low VOC's make this an environmentally friendly varnish. Cure cycle is 1-3 hours at 350°F or 3-5 hours at 300°F. Bond strength is 35/15 lbs. at 25°/155°C.



CONTAINER	PART NUMBER
5 Gallon	CC-1141-5GAL
55 Gallon	CC-1141-55GAL

CC-1115 CLASS F (155°C)

CC-1115 is a one part thixotropic epoxy resin, formulated for VPI systems where low viscosity and excellent penetration and retention are desired. It has excellent moisture and chemical resistance. Excellent thermal shock properties and high flash point. Cure cycle is 3-5 hours at 325°F or 7-9 hours at 300°F. Build 3.5-4.5 mils.



CONTAINER	PART NUMBER
1 Gallon	CC-1115-1
5 Gallon	CC-1115-5
55 Gallon	CC-1115-55

SOLVENTLESS POLYESTER VARNISHES

B7-373A CLASS H

A semi-rigid 100% reactive solventless polyester resin developed for VPI and dip applications. Excellent chemical and moisture resistance. Exhibits excellent penetration capability with good build. Long catalyzed storage life with fast gel time. Comes with B7-373B catalyst, must be mixed before use. Recommended cure cycle 1-4 hours at 150°C.



CONTAINER	PART NUMBER
1 Gallon	B-7-373A-1GAL
5 Gallon	B-7-373A-5GAL
55 Gallon	B-7-373A-54GAL

CC-1305 CLASS H (180°C)

100% solids resilient polyester resin developed for use in VPI and dip and bake applications. Flash point in excess of 200°F and low VOC makes this a safe varnish to use. The high build helps give CC-1305 its excellent chemical and moisture resistance. A unique feature of this varnish is that it is flexible in thick sections to resist cracking. It has exhibited excellent tank stability and low tank maintenance requirements. Low odor makes for a pleasant varnish to use. The superior fill and high bond strength produces quieter, cooler running units. Recommended cure is 1 hour at 325°F.



CONTAINER	PART NUMBER
5 Gallon	CC-1305-5GAL
55 Gallon	CC-1305-55GAL

EB-1500 CLASS H



This solventless polyester varnish is the latest development in non-polluting varnish for the electrical rebuilder. A semi-rigid 100% reactive polyester varnish for dip and bake, as well as vacuum pressure impregnation. Color, Amber; Viscosity, 1163 cps; Flash point >300°F, Gel Time at 118°C 24 minutes; build per dip .6 mil; shore D hardness 80, cure time:
 2-4 hours @ 300°F
 4-8 hours @ 285°F
 8-12 hours @ 275°F

CONTAINER	PART NUMBER
5 Gallon	EB-1500-5GAL
55 Gallon	EB-1500-55GAL

B-7-606 CLASS H



Solventless polyester varnish that exhibits extra high bond strength. High flash point (>200°F) makes this one of the safer varnishes. Works well in dip & bake applications, as well as VPI applications. Low viscosity gives excellent penetration and low build for easy clean up. Recommended cure cycle 2-4 hours at 300-320°F. Dielectric strength is 3000 volts/mil dry. Hermetic approved with longer cure cycle.

CONTAINER	PART NUMBER
5 Gallon	B-7-606-5GAL
55 Gallon	B-7-606-55GAL

FINAL INSULATION - AIR DRY VARNISHES

FUNGUS RESISTANT AC-46 CLASS F (160°C)



High temperature polyurethane electrical insulation that dries very quickly to a tough clear, chemically resistant film. Clear color. AC-46 air dries in about 10 minutes complete cure in about 1 hour, can be baked at 300°F for 10-15 minutes to improve its already excellent moisture and chemical resistance. Dielectric strength (dry) 2000 volts/mil (wet) 1200 volts/mil. Build 2.5-3 mils. Thinner T-200X Xylol.

CONTAINER	PART NUMBER
1 Gallon	AC-46-1
5 Gallon	AC-46-5
55 Gallon	AC-46-55

30 RED PROTECTIVE SEALER



Pedigree No. 30 prevents underlying insulation windings from being attacked by oils, greases, gas, acid, alkalis or water. It assures complete cover if applied carefully by dipping, spraying or brushing. Its smooth appearance is tough, withstanding considerable abuse when electrical apparatus is in operation. It is flexible, heat and arc resistant, dust repellent. Best air drying results, dip units between 120°F to 130°F unit temperature.

CONTAINER	PART NUMBER
1 Gallon	H3001
5 Gallon	H3005
55 Gallon	H3055

434-66 AND 434-66 BLACK (220°C)



High temperature electrical insulation that dries very quickly to a tough, clear amber, moisture resistant film. Also available in black. Air dries in about 15 minutes, complete cure in about 1 hour, can be baked at 250°F for 2 hours to improve its already excellent moisture resistance. Dielectric strength (dry) 3140 volts/mil (wet) 2600 volts/mil. Bond Strength .7 at 150°C.

CONTAINER	PART NUMBER
1 Gallon	H43401
5 Gallon	H43405
55 Gallon	H43455
1 Gallon	H434B01 (Black)
5 Gallon	H434B05 (Black)
55 Gallon	H434B55 (Black)

77X-010 AIR DRY UL THERMAL CLASS 130 THROUGH 180

A clear, fast drying or low temperature cure insulating varnish for impregnating and seal coating of electrical apparatus. Excellent moisture and chemical resistance. Color amber, flash point 70°C, Dielectric strength (dry) 4000 volts/mil, (wet) 2680 volts/mil.

CONTAINER	PART NUMBER
1 Gallon	H77X01001
5 Gallon	H77X01005
55 Gallon	H77X01055



FINAL INSULATION - SOLVENTLESS EPOXY VARNISHES

E-900-LV/900-T CLASS H (180°C)



A single component solventless epoxy resin for use in VPI or dip and bake applications. Two types available, low viscosity is for use in form wound coils and transformers and thixotropic for use on random wound coils that require a higher build. This resin offers outstanding bond strength, chemical resistance and physical properties. Whether the application requires low viscosity for better penetration or thixotropic for higher build, E-900LV gives you the resin to suit your needs. Flash point is >250°F. Recommended cure cycle is 2-4 hours at 325° to 350°F. Bond strength is 47.9/4.4 lbs. at 25°/150°C.

CONTAINER	PART NUMBER
5 Gallon	HE900LV05
55 Gallon	HE900LV55
5 Gallon	HE900T05 (Thixo)
55 Gallon	HE900T55 (Thixo)

B-7-619 CLASS H (180°C)



A single part 100% reactive epoxy resin specially designed for superior performance in VPI systems. Meets mine, navel, and nuclear plant approval. Low viscosity enhances performance by providing excellent penetration in form coil applications. Slightly thixotropic to give complete and void-free impregnation in random wound equipment. Dielectric strength 2760 volts/ mil. Cure cycle 4-6 hours at 150°-160°C. Bond strength is 67/6.7 lbs. at 25°/150°C.

CONTAINER	PART NUMBER
5 Gallon	B-7-619-5GAL
55 Gallon	B-7-619-50GAL
55 Gallon	B-7-619LV-55GAL (Low Viscosity)

CC-1118-LV CLASS H



A unique, one part, thixotropic epoxy resin for use where high voltage, low corona, superior chemical resistance, and excellent electrical insulation properties at elevated temperatures are required. Allows dipping at temperature in excess of 150° to improve impregnation and shorten process time. Thixotropic gives excellent penetration and complete encapsulation. Exhibits exceptional tank stability. Routine tank maintenance and cooling not required. Meets mil spec MIL-M-1760E. Specifically formulated for VPI, yet works in dip applications too. Cure cycle 4-6 hours at 325°F for maximum chemical resistance.

CONTAINER	PART NUMBER
1 Gallon	CC-1118LV-1
5 Gallon	CC-1118LV-5
55 Gallon	CC-1118LV-55

FINAL INSULATION - SOLVENTLESS VARNISHES

CC-1105 CLASS N (205°C)



A truly unique solventless polyester varnish. The high flash point (329°F) and low odor make this an excellent choice for varnish. Low viscosity gives excellent penetration and minimal clean up. High bond allows it to be used on rotating equipment. Years of use in the field has shown its excellent tank stability. Recommended for use on hermetics. Recommended cure cycle 15 minutes at 350°F or 35 minutes at 325°F. It is also available as filled polyester resin (HTC).

CONTAINER	PART NUMBER
1 Gallon	CC-1105-1
5 Gallon	CC-1105-5
55 Gallon	CC-1105-55
5 Gallon	CC-1105HTC-5
55 Gallon	CC-1105HTC-55

600 DAP CLASS H (180°C)



A solventless polyester resin formulated for use in VPI systems, but works equally well in dip and bake applications. Its low viscosity gives excellent penetration with good slot fill. 600 DAP has excellent tank stability and a flash point >250°F. Recommended cure cycle is 4-6 hours at 275° to 350°F. Bond strength is 40/21 lbs. at 25°/150°C.

CONTAINER	PART NUMBER
5 Gallon	H600DAP05
55 Gallon	H600DAP55

433-75-VTC CLASS H (180°C)



A high performance solventless polyester resin formulated expressly for use in VPI systems. This resin has excellent chemical resistance and excellent tank stability. Medium viscosity and cures to a clear high bond strength film. Flash point is 127°F. Recommended cure cycle is 2-4 hours at 300° to 350°F. Bond strength is 46/13 lbs. at 25°/150°C.

CONTAINER	PART NUMBER
1 Gallon	H135443375VTC1
5 Gallon	H135443375VTC5
55 Gallon	H135443375VT55

CC-1405 CLASS H (180°C)



A truly unique solventless polyester varnish, specifically developed to provide superior moisture resistance and good watability. It can be used in VPI as well as dip and bake. The high flash point (200°F) and low odor make this an excellent choice for varnish. Low emissions and superior moisture and chemical resistance. Bond strength 30# at 25°C and 12# at 155°C. Years of use in the field has shown its excellent tank stability. Recommended cure cycle: 15 minutes at 350°F, 35 minutes at 325°F. Dielectric: dry 3800, wet 3000 (volts/mil). Color clear/amber.

CONTAINER	PART NUMBER
55 Gallon	CC-1405-55GAL

CC-1133 CLASS H (180°C)



A flexible one part solventless unsaturated polyester varnish. Excellent for D.C. traction coils, formed wound coils and transformers. The flash point is (142°F). Offers low emissions, excellent appearance and good electrical properties. Good for both VPI and dip and bake. Bond strength 35# at 25°C and 10# at 155°C. Years of use in the field has shown its excellent tank stability. Recommended cure cycle 1-2 hours at 325°F. Dielectric: dry 3500, wet 2200 (volts/mil). Build 3-4 mils.

CONTAINER	PART NUMBER
5 Gallon	CC-1133-5
55 Gallon	CC-1133-55

PR477 CLASS H (180°C)



This varnish is a polyester resin that is ideal for VPI systems or dip and bake. This varnish is suitable for motors, coils, stators and high voltage transformers. Has low viscosity and high thermal capabilities. The monomer is vinyl toluene. The flash point (127°F). Bond strength 21.6# at 25°C and 1.9# at 150°C. Years of use in the field have shown its excellent tank stability. Recommended cure cycle 4-6 hours at 325°F. Dielectric: dry 2180, wet 1800 (volts/mil).

CONTAINER	PART NUMBER
5 Gallon	HPR47705
55 Gallon	HPR47755

FINAL INSULATION - SOLVENT BASED VARNISH

B-346A CLASS N (215°C)



A specially formulated solvent-based polyester varnish for use in up to Class H systems. For a low price, BC-346A will give high build with excellent flexibility. It exhibits excellent moisture and chemical resistance. Meets Mil spec MIL-I-24092/D. Excellent for use in transformers, stators, form coils and random wound coils. Dielectric: dry 4,000, wet 2,900 (volts/mil) Recommended cure cycle 1-2 hours at 325°F, 2-1/2-5 hours at 275°F. Build 4-5 mils.

CONTAINER	PART NUMBER
1 Gallon	BC-346A-1
5 Gallon	BC-346A-5
55 Gallon	BC-346A-55

711-F2106 CLASS H (180°C)

A solvent-based modified polyester varnish that is widely accepted throughout the electrical industry. Its long life, ease of maintenance and application has made it a successful varnish for many years. Medium viscosity provides good penetration and good film build. Meets mil spec MIL-I-24092. Flash point is 55°F. Recommended cure cycle is 2-6 hours at 300°-350°F. Bond strength is 20.8/1 lbs. at 25°/150°C.



CONTAINER	PART NUMBER
1 Gallon	H711210601
5 Gallon	H711210605
55 Gallon	H711210655

BC-352 CLASS H (180°C)



A one part, high bond strength, clear epoxy varnish that offers the highest resistance to chemicals, solvents and moisture. Provides protection to windings that must operate in corrosive conditions. Recommended for hermetic motors in fluorinated refrigerants, as well as stators, armatures, laminations and rotating field coils. Dielectric: dry 4600, wet 3600. Recommended cure cycle 2-4 hours at 300°F. Build 3-4 mils.

(See Part Numbers to right.)

BC-359 CLASS H (180°C)



A versatile cure cycle makes this solvent based varnish truly unique, a fast cure can be obtained at low temperature or an ultra fast cure at high temperature. Provides superior moisture resistance and excellent chemical and abrasion resistance. Low cost and meets Rule 66 air pollution standards. Excellent for motors, relays, transformers, stators, form wound coils and random wound coils. Dielectric strength: dry/wet: 3000 volt/mil. Recommended cure cycle 1/2-1-1/2 hours at 325°F or 8-10 hours at 230°F.

CONTAINER	PART NUMBER
1 Gallon	BC-359-1
5 Gallon	BC-359-5
55 Gallon	BC-359-55

923 EPOXY HERMETIC INSULATION VARNISH



It is the varnish of choice by the refrigeration compressor industry. Along with its excellent freon resistance, it is impervious to harsh chemical environments. The product is available in both 35% and 50% solids (by weight) for customer convenience. High bond strengths, low to medium viscosity, excellent tank stability. Color is clear amber. Flash point for 35% 83°F and 50% 94°F. Dielectric strength: dry 4000 volt/mil, wet 3200 volts/mil. Bond strength is 35.3/6.7 lbs. at 25°/150°C.

CONTAINER	PART NUMBER - 35%	CONTAINER	PART NUMBER - 50%
1 Gallon	H9233501	1 Gallon	H9235001
5 Gallon	H9233505	5 Gallon	H9235005
55 Gallon	H9233555	55 Gallon	H9235055

CONTAINER	PART NUMBER
1 Gallon	BC-352-1
5 Gallon	BC-352-5
55 Gallon	BC-352-55

Y-210 CLASS H (180°C)



A general purpose solvent based modified polyester varnish that is an industry standard for a variety of applications. Typical uses include stator, coil and transformer impregnation. Meets mil spec MIL-I-24092. Flash point is 85°F. Recommended cure cycle is 2-4 hours at 300°-350°F. Bond strength is 27/2.7 lbs. at 25°/150°C. Uses Xylol thinner.

CONTAINER	PART NUMBER
5 Gallon	HY21005
55 Gallon	HY21055

LOW VOC Y-210M CLASS H (180°C)



This is a low VOC compliant varnish, with high solids. It is a general purpose solvent based modified polyester varnish that is an industry standard for a variety of applications. Typical uses include stator, coil and transformer impregnation. Meets mil spec MIL-I-24092. Flash point is 80°F. Recommended cure cycle is 2-10 hours at 300°- 350°F. Bond strength is 22.7/1.9 lbs. at 25°/200°C. Dielectric: 3440/ 3050 (volts/mil). Build 1.15 mils. Uses thinner Oxsol-100 (OX100).

CONTAINER	PART NUMBER
5 Gallon	HY210M05
55 Gallon	HY210M55

BEI-915A CLASS H



A low-heat cure modified polyester-solvent base, clear baking varnish. Retains its light amber color for well over a year and gives off virtually no odor. Exhibits excellent oil and moisture resistance, high bond strength and excellent adhesion. Dielectric strength is 4400 volts/mil when dry. A classic dip & bake varnish that conserves energy because of its fast cure cycle. Recommended cure cycle 2-4 hours at 250-275°F.

CONTAINER	PART NUMBER
1 Gallon	BEI-915A-5GAL
15 Gallon	BEI-915A-15GAL
55 Gallon	BEI-915A-55GAL

FINAL INSULATION

WET WINDING COMPOUNDS

When winding field coils that require a high degree of turn to turn bond strength, you can brush one the following compounds on each layer as you are winding it. These components exhibit no sag even on vertical surfaces, and have extremely high bond strengths. Apply with a stiff bristle brush or trowel. Because of the unique characteristics they have relatively short shelf life, and the material should be stored under refrigeration. One gallon units are shown because of short shelf life, larger units are available. Basic cure cycles are shown, properties can be improved by additional cure cycles, consult specific data sheets for more information.

CLASS F (155°C)

MFG.	TENSILE STRENGTH @ 25°C	FLEXURAL STRENGTH @ 25°C	SHELF LIFE @ 25°C	CURE CYCLE @ 150°F	PART NUMBER
Sterling	11,450 PSI	12,470 PSI	4 months	8 Hrs.	HU3002001
Dolph			12 months	7-8 Hrs.	CN-1119-1

SILICONE VARNISH

DC 997 CLASS R

Silicone resin varnish that exhibits excellent bond strength even at high temperatures. Contains excellent electrical properties and moisture resistance. Easy to use. Meets mil spec MIL-I-24092B. Flash point 80°F. Initial cure cycle 2-4 hours at 302° - 392°F. If equipment is to be operated at temperatures higher than 200°C, should be given an additional cure of 6 hours at 482°F.

DOW CORNING

CONTAINER	PART NUMBER
1 Gallon	DC-997-1
5 Gallon	DC-997-5
55 Gallon	DC-997-55

SPRAYON CLEAR INSULATING VARNISH

Clear insulating varnish. Thoroughly penetrates old and new material, air dries faster than most insulating aerosols. Provides high adhesion, high arc-resistance and non-tracking properties.

- Air Dries in 10-15 minutes; tack free in 60 minutes.
- Use as insulating varnish in Class F applications, as well as a topcoat.
- Resists abrasion and wear.
- Contains no chlorinated solvents.
- Dielectric Strength 2,100 VPM.
- Equipped with DanVern standard valve.



Sprayon

CONTAINER	PART NUMBER
16 oz.	SPN-600

NEW RANVAR 2000 SOLVENTLESS MODIFIED EPOXY VARNISH

New B-7-1000 is a modified epoxy designed for Vacuum Pressure Impregnation systems. This single component product is reliant, chemical and moisture-resistant. It is VOC compliant. If an additional film build and bridging is required, a thixotropic version is available (B-7-1000T). Color: Light amber; Weight/gallon 8.9.

RANBAR

NEW RANBAR VARNISHES

NEW RANVAR 2009

RANVAR 2009 a solventless VPI EPOXY POLYESTER VARNISH. If the thermal properties of a polyester and the chemical resistance of an epoxy are required ... the need for two tanks can be eliminated. Use RANVAR 2009 and achieve the required properties with one product. This product is not a blend. It is an actual reaction whose end results give you the best of both worlds.



FEATURES:

- Low VOC
- Solventless
- Superior moisture resistance
- Excellent chemical resistance
- Excellent film build
- High bond strength
- Good flexibility
- VPI only

Color: Amber
Weight per gallon - 8.9
Viscosity @ 25°C - 800±100
Film Build - 1.5 Mils
Flash Point - 127
VOC - 1.9 lbs/gal
Shore Hardness @25°C-80
Bond strength @25°C-28
Dielectric 3250 Dry / 2800 Wet

CONTAINER SIZE	PART NUMBER
5 Gallon	RV-2009-5GAL
55 Gallon	RV-2009-55GAL
Catalyst	RV-2009B
Viscosity Reducer	BS-217
Inhibitor	RV-2009INH

NEW RANVAR B-7-1000

RANVAR B-7-1000 a solventless VPI MODIFIED EPOXY VARNISH. VOC compliant, proprietary modified epoxy which is designed for vacuum pressure impregnation. For additional film build and bridging, thixotropic version is available B-7-1000T.



FEATURES:

- Low VOC
- Solventless
- Superior moisture resistance
- Excellent chemical resistance
- Excellent film build
- High bond strength
- Low run off
- Class 180°C

Color: Amber
Weight per gallon - 8.9
Viscosity @ 25°C - 800±100
Film Build - 1.5 Mils
Flash Point - 127
VOC - 1.9 lbs/gal
Shore Hardness @25°C-80
Bond strength @25°C-28
Dielectric 3250 Dry / 2800 Wet

CONTAINER SIZE	PART NUMBER
5 Gallon	B-7-1000-5GAL
55 Gallon	B-7-1000-55GAL
Catalyst	B-7-1000B
Viscosity Reducer	BS-217
Inhibitor	B-7-1000INH

NEW RANVAR 2010R

RANVAR 2010R is a solvent based CO-POLYMER VARNISH. It is high in solids, chemical and moisture resistant, low VOC, proprietary co-polymer recommended for applications by static dip and bake or roll varnish. This high quality varnish provides the bond strength, insulation protection and chemical resistance required for outstanding protection to electric motors, stators and related electrical apparatus.



FEATURES:

- Low VOC
- Mild odor
- Outstanding moisture resistance
- Excellent chemical resistance
- Excellent film build
- High bond strength
- Low run off

Color: Amber
Dielectric 3600 Dry / 2800 Wet
Cure 2-4 Hours @ 300-325°F

CONTAINER SIZE	PART NUMBER
5 Gallon	RV-2010R-5GAL
55 Gallon	RV-2010R-55GAL

FINAL INSULATION - THINNERS AND REDUCERS

VARNISH TANK MAINTENANCE

Routine maintenance on solvent based varnishes is relatively simple. First determine your viscosity. Add thinner or fresh varnish as required. When maintaining a water based or solventless varnish it is important to get the varnish manufacturer involved in testing the varnish. If you routinely send a sample of your varnish into the manufacturers they will perform several tests on the varnish and advise as to what and how much of the appropriate material should be added to the tank to keep it in tip top condition. Below are a few items that will help maintain the tank.

DESCRIPTION	PART NUMBER
Dolph Viscosimeter	TVM-100
Viscosity Cup & Thermometer	VISC 100 KIT
Dolph Quart Sample Can	DLH-SAMPLE-CAN-QT
Ranbar Quart Sample Can	RBR-SAMPLE-CAN-QT

THINNERS

When adding thinner to the tank it should be added slowly with strong agitation. Never leave thinner sitting on the surface of the tank for a period of time, as this can cause solids separation. It is not a good practice to add more than 10% by volume in one addition, if more than 10% needs to be added, do it in two or more additions. The temperature of the thinner should be roughly about the same temperature as the varnish to avoid curdling.

PRODUCT	SIZE	DOLPH PART NUMBER	RANBAR PART NUMBER
VM&P	1 Gallon	T-100-1	BS-50-1GAL
Naptha	5 Gallon	T-100-5	BS-50-5GAL
	55 Gallon	T-100-55	BS-50-55GAL
Xylol	1 Gallon	T-200X-1	BS-107-1GAL
	5 Gallon	T-200X-5	BS-107-5GAL
Oxsol*	55 Gallon	T-200X-55	BS-107-55GAL
	5 Gallon	OX-100-5	
	55 Gallon	OX-100-55	

*Mfg. by Mozel Inc.

T-723 TAPE ADHESIVE

Sterling (PD George) T-723 adhesive is a thermosetting binder having unusual adhesive qualities. It will bind to all types of tapes, such as: mica, cotton, varnished cambric, treated and untreated glass tape.



CONTAINER	PART NUMBER
1-3/4 oz. Tube	HT723
1 Gallon	HST72301
5 Gallon	HST72305

PRODUCT	THINNER	PRODUCT	THINNER
AC-41	T-200X	CW-340-1	T-50
AC-43	T-200X	DC-1890	T-100
AC-46	T-200X	DC-997	T-200X
B-277-2	T-200X	ER-41	T-200X
B-6-310-1	T-200X	GLP-1201	T-1500
B-6-311B	T-200X	GLP-9921	T-200X
B-6-640	BS-130	LAM-COAT	N/A
B-7-610	N/A	LC-705	T-220
B-7-611	N/A	Y-210	T-200X
B-7-612	T-200X	Y-210M	OX-100
B-706	N/A	30	T-200X
BC-346A	T-100/T-200X	434	T-200X
BC-359	T-100	711-F2106	T-200X
BEI-915A	T-100/T-200X		
CB-1057	T-200X		
CB-1128	T-200X		
CC-1120	N/A		
CR-1034H	N/A		
CR-1035	N/A		
CW-1081	N/A		

VISCOSITY REDUCERS

When maintaining solventless varnish tanks, it's not as simple as adding thinner to reduce the viscosity. Samples must be submitted to the manufacturers of the varnish on a regular basis. They will advise of the proper amount of reducer that should be added. Without the aid of the manufacturer of the varnish, severe damage can be caused to the varnish in your tank.

VARNISH	SIZE	INHIBITOR PART NUMBER	VISCOSITY ADJUSTER PART NUMBER
CC-1105	1 Gallon	M-2016-1GAL	VSR-3015-1
	5 Gallon		VSR-3015-5
CC-1305	1 Quart	M-2016-1QT	
	1 Gallon	M-2016-1GAL	VSR-3015-1
B-7-373	5 Gallon		VSR-3015-5
	1 Gallon	B-7-374-1GAL	BS-217-1GAL
B-7-606	5 Gallon	B-7-374-5GAL	BS-217-5GAL
	55 Gallon		BS-217-55GAL
EB-1500	1 Gallon		BS-221-1GAL
	5 Gallon	B-7-618-5GAL	BS-221-5GAL
PR477	55 Gallon		BS-221-55GAL
	1 Gallon	H644001	H284901
433-75	5 Gallon	H64404(QT)	H284905
	55 Gallon		H284955
600DAP	1 Gallon	H644001(PT)	H284901
	5 Gallon	H644005(QT)	H284905
600DAP	55 Gallon		H284955
	5Gallon		HDAP05
	55 Gallon		HDAP55

FINAL INSULATION - VARNISH KITS

Varnish kits are an excellent method of impregnating windings when you need to get the motor back to your customer fast. Once you have rewound the stator and completed tying it down, simply heat the stator by applying reduced voltage to the windings. Mix the varnish kit and pour it over the end turns while the stator is standing on end. After you have saturated the winding, flip the stator over and saturate the other end. Continue heating the winding until the varnish cures. Clean up any spillage that may have occurred in the bore. Assemble the motor and you are ready to get your customer back in service!

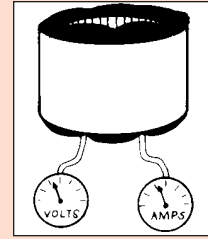
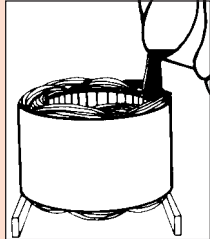
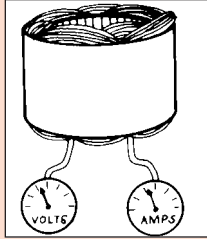

MFG.	CLASS & TYPE	DESCRIPTION	COLOR	HARDNESS SHORE "D" @ 77°F	POT LIFE	CURE TIME	SIZE	PART NUMBER
Ranbar	Class B Solventless Epoxy	Two part solventless epoxy kit designed for Flow On application for impregnation & sealing stators, coils and transformers. Good for hermetics.	Light Amber	91/89	45 Minutes @ 77°F	30 Min. @ 135°F or 72 Hours @ 77°F	Pint Quart Gallon 5 Gallon	B-7-613-1PT B-7-613-1QT B-7-613-1GAL B-7-613-5GAL
Dolph	Class F Solventless Epoxy	A unique semi-rigid epoxy. Fast cure with a long pot life. Excellent moisture and chemical resistance.	Amber	70	3 Days	15 Min. @ 275° F	Pint Quart 5 Gallon	CC-1089-1 CC-1089-2 CC-1089-16
Dolph	Class F Solventless Epoxy	Low viscosity epoxy, semi-rigid, for impregnating and sealing stators, coils, and transformers. Cures at low temperatures. Good for hermetics.	Amber	70	45 Minutes @ 70°F	15 Min. @ 135°F	Pint Quart Gallon 5 Gallon	CC-1095-1 CC-1095-2 CC-1095-8 CC-1095-50
Ranbar	Class H Solventless Polyester	Two component system designed for pour through application on random wound stators and rotors.	Amber	70/30	4 days @ 77°F	30 Min. @ 275°F	Pint Quart Gallon	B-7-614-1PT-FC B-7-614-1QT-FC B-7-614-1GAL-FC
Dolph	Class H Solventless Polyester	Low viscosity polyester, semi-rigid, for impregnating and sealing stators, armatures, coils and transformers. Low cost system. Low temperature cure.	Amber	78	4 Hours @ 70°F	15 Min. @ 150°F	Pint Quart 5 Gallon	CC-1094-1 CC-1094-2 CC-1094-45
Ranbar	Class H Solventless Epoxy	Two component system designed for impregnating and sealing stator windings	Amber		35-50 Minutes	35-50 Min.	1/2 Pint Pint Quart	B-7-206-1/2-PT-KIT B-7-206-PT-KIT B-7-206-QT-KIT

CROSS REFERENCE FROM EPOXYLITE TO RANBAR AND DOLPH PRODUCTS

EPOXYLITE	DESCRIPTION	RANBAR PART NUMBER	DOLPH
113-67-1	Brush on Mold Release	B-213	
203	Sealer Paste, Black	B-9-110-A/B	CB-1057/CR-1034H
211	Brush on Compound, Tan	B-9-110-1LV	CO-1060
213	Air Dry Electric Motor Sealer	B-9-136-A/B	CW-1081
230	Trickle Impregnation Resin	B-9-102-A/B	CC-1095
234	Trickle Impregnation Resin	B-7-206	CC-1095
236	Trickle Impregnation Resin	B-7-206	CC-1089
293	Thermal Shock Potting Resin	B-9-140-A/B	CB-1054
478	VPI Resin	B-7-619	CC-1115/ CC-1118LV
707	Field Coil Bonding Compound		CN-1119
8020	Wet Winding Compound	B-7-300WW	CN-1119
805	Transformer Potting Compound	B-7-646	CB-1054
8117	Semi Rigid Butter On	B-7-610	CR-1034H

FINAL INSULATION - COATINGS

BUTTERING

Varnish winding using normal procedures. Apply resin to warm stator using a spatula or flat stick, making sure to get good coating on the end turns and contact with the laminations. Once the resin has partially set, use a rag soaked in thinner to insure a complete seal and give the unit a smooth glossy finish.

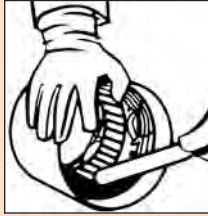

SPRAYING OR BRUSHING

Varnish the unit using normal procedures. Some resins may need to be thinned for spraying. (See chart on page 35 for thinners.) Spray resin on winding using a siphon spray gun. Remove any excess resin using a rag soaked in thinner. Allow to cure and assemble the motor for use.



CASTING OR POTTING

Varnish application is not required with all types of potting compounds. Build dike around the winding, sealing the ends of the dikes with a buttering compound to keep the potting compound from running out. Pour the resin into the mold from one spot to reduce the chance of trapping air in the mold. Once partial cure has occurred, remove the dikes and remove any excess resin.



APPLICATION METHOD	MFG.	DESCRIPTION	COLOR	HARDNESS	POT LIFE	TEMP. CLASS	CURE TIME	SIZE	PART NUMBER
Buttering	Dolph	Thixotropic epoxy paste semi-rigid for stators, armatures, coil ends, and marginal ends of transformers.	Red	80	90 Min. @ 70°F	B	3-4 Hours @ 70° F	Pint Quart Gallon 5 Gallon	CR-1034H-1 CR-1034H-2 CR-1034H-8 CR-1034H-50
	Dolph	Thixotropic epoxy paste, flexible, 1:1 mixing ratio, for stators, armatures, coil ends, and marginal ends of transformers	Black	70	2 Hours	B	2-4 Hours @ 70° F	Pint Quart Gallon 5 Gallon	CB-1057-1 CB-1057-2 CB-1057-8 CB-1057-50
	Dolph	One part compound for sealing stator end turns for abrasion resistance.	Beige			F	2-4 Hours @ 285° F	2 Gallon 5 Gallon	CW-340-1-2 CW-340-1-5
	Ranbar	Thixotropic epoxy paste, semi-rigid for stator and armature coil ends.	Red	90/88	2-4 Hours	B	3 Hours @ 150°F	Pint Quart Gallon	B-7-610-1-PT B-7-610-1QT B-7-610-1GAL
Brush	Dolph	Thixotropic resin, extremely flexible seals out moisture, excellent chemical, abrasion and crack resistance.	Black	Shore A 45	45 Min.	F	3-4 Hours	Pint Quart Gallon	CB-1128-1 CB-1128-2 CB-1128-8
	Dolph	Thixotropic epoxy, flexible for "spray-on" protection of motor stators.	Brown	55	6 Hours	B	1 Hour @ 150° F	Pint Quart 5 Gallon	CW-1081-1 CW-1081-2 CW-1081-16
Or Spray	Dow Corning	One part silicone rubber sealant for protection against moisture and abrasion.	Gray			H	15-30 Min. @ 70° F	Gallon 5 Gallon	DC-1890-1 DC-1890-4.5
	Ranbar	Thixotropic epoxy resin for chemical and moisture protection of stators. Will not sag during cure cycle.	Brown	55/25	8 Hours	B	1-2 Hours	Pint Quart Gallon	B-7-612-1PT B-7-612-1QT B-7-612-1GAL
Ranbar	Thixotropic two part epoxy resin for protection from grit, moisture and chemicals	Brown	27-30	3-4 Hours			Pint	B-9-136A/B-PT	
Potting	Dolph	Low viscosity epoxy, semi-rigid for casting stators, solenoid coils, and control coils.	Red	75	90 Min.	B	2-4 Hours @ 70° F	Pint Quart Gallon 5 Gallon	CR-1035-1 CR-1035-2 CR-1035-8 CR-1035-50
Casting	Dolph	Extremely flexible low viscosity compound for potting electromagnets	Clear	Shore A 35	70 Min.	F	3 Hours @ 70° F	Gallon 5 Gallon	CC-1120-1 CC-1120-5
	Ranbar	Flexible resin for potting lifting magnets and transformers for protection against moisture.	Amber	30	15-30 Min.	B	30 Min. @ 70° F	Quart Gallon 5 Gallon	B-706-1QT B-706-1GAL B-706/PL-KIT
Filling	Ranbar	Epoxy resin for potting lifting magnets in high temperature applications.	Amber	30/12	8 Hours	F	1 - 2 Hours @ 275° F	Quart Gallon	B-7-611-1QT B-7-611-1GAL
	Ranbar	A two part epoxy resin, thixotropic and filled. Recommended for chemical and corrosive applications	Black	82/84	30-45 Min.	F	4-6 Hours	Pint Quart Gallon 5 Gallon	B-7-110AB-PT B-7-110AB-QT B-7-110AB-GL B-7-110AB-5
	Ranbar	A two part epoxy resin, thixotropic and highly filled. Designed for general purpose potting and molding.	Black	79-81	50-60 Min.	F	4 Hours @ 70° F	Quart	B-7-646-AB-QT

FINAL INSULATION - PAINTS

AC-41 CLEAR POLYURETHANE VARNISH CLASS F (160°C)

A unique high temperature insulator that dries in 30 min. to a tough, clear, chemical resistant film.



Can be applied by brush, dip or spray. Oil and moisture resistant, excellent for coating circuit boards. Exhibits superior abrasion resistance and adhesion. Thin with T-200X. Use for coating field coils, commutator ends, electrical connections, stators, etc.

SIZE	PART NUMBER
1 Gallon	AC-41-1
5 Gallon	AC-41-5
55 Gallon	AC-41-55

GLYPTAL RED INSULATOR (135°C)

This enamel exhibits unsurpassed resistance to corrosion, moisture, oil, acid, heat, dust and salt spray. Its outstanding adhesion allows it to stick to most any surface. Meets mil spec MIL-E-22118. 1500 volt/mil dielectric strength. Dries tack free in approximately 30 minutes.

SIZE	PART NUMBER
20 oz. Spray	GLP-1201-A-SPRAY
1 Quart	GLP-1201-1QT
1 Gallon	GLP-1201-1GAL
5 Gallon	GLP-1201-5GAL

DOLPH SPRAY VARNISH CLASS A (105°C)

This varnish is specially formulated to have outstanding resistance to moisture and fungus. Good flexibility when cured. Dries to the touch in 30 minutes tack free in 3-1/2 hours. Clear. Conforms to MIL-V-173C-2. Dielectric strength 2000 volts/mil.



SIZE	PART NUMBER
20 oz. Spray	DS-AC-46-AF

SEMI CONDUCTIVE PAINTS

When working on motors and generators that operate above 5KV, it is a good practice to bleed off the corona discharge that is created around the coils. The primary areas of concern are in the slot where small gaps can occur between the coils and the iron, and where the coils exit the iron. One method is to paint the coils with a semi conductive paint to bleed off the discharge.

RESISTIVITY				
BRAND	COLOR	OHMS / SQ.	SIZE	PART NUMBER
RANBAR	BLACK	2000-7500	QUART	B-2-135-1QT
RANBAR	BLACK	2000-7500	GALLON	B-2-135-1GAL
GLYPTAL	DK GREEN	2000-20,000	GALLON	GLP-9921-1GAL

INSULATING PAINTS

VANGUARD INSULATOR CLASS F (155°C)

This insulating enamel resists oil, water, acids and alkalis. Adheres well to all metal surfaces curing to a smooth glossy finish. The film is tough, flexible, arc and track resistant. Dries to the touch in 15 minutes. Dielectric strength is 2000 volts/mil when dry. Available in red or black.



COLOR	SIZE	PART NUMBER
RED	20 oz. Spray	VSP-E-208
RED	1 Gallon	VSP-E-208-1
RED	5 Gallon	VSP-E-208-5
RED	55 Gallon	VSP-E-208-55
BLACK	20 oz. Spray	VSP-E-207

CLEAR INSULATING LACQUER CLASS A (105°C)

A rapid air drying film that dries to a tough, flexible film. Exhibits good corona resistance and good moisture and chemical resistance. Conforms to MIL-I-17384A. Dries in 15 minutes. Dielectric strength 1500 volts/mil.



SIZE	PART NUMBER
20 oz. Spray	DS-LC-705

LAMINATION AND METAL COATER

This spray prevents rust and corrosion on all metal surfaces. Low build assures no problems with air gaps. Light orange tint verifies coverage. Dries to the touch in 10 minutes. Dielectric strength is 2000 volts/mil.

SIZE	PART NUMBER
20 oz. Spray	DS-LAM-COAT

POLYURETHANE INSULATOR CLASS F (155°C)

A unique electrical insulator that dries quickly to a smooth semi-gloss finish. This air dry enamel offers excellent hiding power for rebuilding and manufacturing applications. Exhibits excellent oil and moisture resistance and extraordinary abrasion resistance. Adheres well to most surfaces. Dries to the touch in 10 minutes and completely dries in 30 minutes. 2000 volts/mil dielectric. 20 oz. spray cans.



COLOR	PART NUMBER
RED	DS-ER41-RED
BLACK	DS-EB41-BLK
RED	DS-ER44-RED

LIMITRAK ARC & TRACK RESISTANT COATING



A red surface coating that provides superior insulating qualities and outstanding track resistance. Exhibits outstanding chemical and moisture resistance. Two part system that when mixed can be applied with a brush or thinned for spraying. Dielectric strength is approx. 650 volt/mil in 20 mil thickness. Cure time is approx. 3-4 hours when applied, complete cure in 5 days.

SIZE	PART NUMBER
Quart Kit	B-6-640-QT-KIT
Gallon Kit	B-6-640-1GAL-KIT

FINAL INSULATION - SPRAY PAINTS

VANGUARD SPRAY PAINTS

Vanguard spray paints are specially formulated to dry fast and cover well. The 20 oz. can saves two ways, more product for the money and sprays longer. The colors are professionally blended to match OEM colors as closely as possible. They dry to the touch in as little as 10 minutes. Special spray nozzle allows for fine spray pattern control.



ACRYLIC ENAMELS AND EPOXY

COLOR	DESCRIPTION	PART NUMBER
Light Gray	Matches G.E. Finishes	VSP-E-200
Blue Gray	Matches G.E. & Westinghouse Finishes	VSP-E-201
Gloss White	Dairy & Food Processing	VSP-E-202
Gloss Black	Gloss Black Enamel	VSP-E-203
Dark Gray	"Motor" gray	VSP-E-204
Ultra Light Gray	Matches ASA 70	VSP-E-205-20
Orange	Orange Enamel	VSP-E-206
Gold	Pool & Spa Gold	VSP-E-209
Yellow	Yellow Enamel	VSP-E-213-20
Red	Red Enamel	VSP-E-214
Flat White	Flat White Enamel	VSP-E-215-20
Ford Blue	Matches Ford Blue	VSP-E-211
Epoxy Green	Epoxy Green Varnish	SPN-609
Epoxy Blue Green	Reliance Blue Green Touch-up	VSP-514

LACQUER

COLOR	DESCRIPTION	PART NUMBER
Medium Gray	Medium Gray	VSP-L-100
Blue Gray	GE Blue Gray	VSP-L-101
Custom Gray	Matches Century Gray	VSP-L-102
Dark Gray	Dark Gray	VSP-L-103
Black	Black Lacquer	VSP-L-104
Brute Blue	Pumps and other Equip.	VSP-L-105
Red	Pumps and signal	VSP-L-106
Yellow	Hoists and Pumps	VSP-L-107
Green	Pumps and other Equip.	VSP-L-108
White	Dairy & Food Processing	VSP-L-109
Aluminum	Protective coating	VSP-L-111

RANBAR ENAMELS

A line of paints that offers fast drying times and excellent coverage. From the fast dry enamels that have good oil & chemical resistance to the modified epoxy enamels that offer the ultimate in oil and chemical resistance. The primers offer the excellent adhesion to most surfaces, and resist corrosion. Packaged in gallon cans for economical use. Can be thinned with Xylol.



COLOR	DESCRIPTION	PART NUMBER
Dark Gray	Acrylic Enamel ANSI 24	B-6-357-1GAL
Flat Black	Insulating Epoxy Enamel	B-6-254-1GAL
Gloss Black	Insulating Epoxy Enamel	B-6-264-1GAL
Gloss Red	Insulating Epoxy Enamel	B-6-665-1GAL
Green	Telephone Green	BT-6650-1GAL
Green Epoxy	Reliance Green Epoxy Enamel	BT-7216-1GAL
Medium Gray	Fast Dry Enamel ANSI 49	B-6-310-1-1GAL
Medium Gray	Fast Dry Primer/Topcoat ANSI 61	B-6-361-2-1-GAL
Red	FMC Red Fast Dry Enamel	BT-7246-1GAL
Red Primer	Iron Oxide Zinc Chromate Primer	B-5-611-1GAL
White	Acrylic Enamel	BT-6970-1GAL
Yellow	Traffic And Zone Marking	B-5-800-1GAL

DOLPH LACQUERS

Fast drying high gloss lacquers designed for electric motor frames, meter boards, control panels, transformer cases, and shop machinery. Dries to the touch in 10 minutes and is tack free in 30 minutes. Rated at 105°C, and has up to 200 volt dielectric strength. 20 oz. aerosol cans.



COLOR	PART NUMBER
White	DS-WHT
Black	DS-BLK
Blue Gray	DS-BLU-GRY
Light Gray	DS-LT-GRY
Dark Gray	DS-DK-GRY

VANGUARD MAINTENANCE SPRAYS

ELECTRIC MOTOR DEGREASER

Specially formulated for cleaning electric motors. Spray over equipment to be cleaned. Wipe off with rag to aid drying. For heavy build-ups allow to soak for five minutes before wiping. Fast drying, and cleans effectively.



PART NUMBER	VSP-500
--------------------	---------

PENETRATING OIL

Specially formulated to free rusted fasteners fast! Excellent for nuts, bolts or any threaded item. Disintegrates rust and hard scale. Corrosion inhibitors are included to reduce future corrosion. Wipe off painted surfaces.



PART NUMBER	VSP-509
--------------------	---------

BLUE LAYOUT FLUID

Pigmented, non-corrosive oil resistant ink provides a marking surface on metal, glass or plastics for precision work. Dries instantly to a non-glaze smooth finish.



PART NUMBER	VSP-513
--------------------	---------

FINAL INSULATION - KRYLON SPRAY PAINT

KRYLON TOUGH COAT PAINTS

These flexible industrial acrylic enamels are ideal for light to heavy duty painting projects, both indoor and outdoor. The tough protective coating resists chipping and peeling.



- **Excellent** hiding characteristics
- **Smooth** even coverage
- **Fast** drying-15 minutes to the touch equipped with the EZ touch Fanspray nozzle

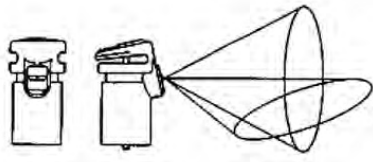

GENERAL PURPOSE COLORS		IMPLEMENT COLORS	
COLOR	PART NUMBER	COLOR	PART NUMBER
Clear Topcoat	KSP-1000	International Harvester Red	KSP-1003
Bright Red	KSP-1005	Allis Chalmers Orange	KSP-1006
Cherry Red	KSP-1101	Ford Blue	KSP-1008
Joy Orange	KSP-1213	Federal Highway Yellow	KSP-1009
Cordova Brown	KSP-1285	Caterpillar Yellow (New)	KSP-1318
Light Beige	KSP-1305	Caterpillar Yellow (Old)	KSP-1320
Machine Green	KSP-1415	John Deere Green	KSP-1485
Medium Green	KSP-1445	OSHA Red	KSP-1110
Dark Blue	KSP-1515	OSHA Equipment Orange	KSP-1210
Light Blue	KSP-1540	OSHA Yellow	KSP-1310
Flat White	KSP-3720	OSHA Safety Green	KSP-1470
Semi-Flat Black	KSP-3725	OSHA Blue	KSP-1510
Max Flat Black	KSP-3727	OSHA Purple	KSP-1580
		OSHA Black	KSP-1770
		OSHA White	KSP-1800
METALLICS		PRIMERS	
COLOR	PART NUMBER	COLOR	PART NUMBER
Aluminum	KSP-1760	Red Oxide Rust Control Primer	KSP-342
Gold	KSP-1765	Gray Rust Control Primer	KSP-340

ADHESIVE TAPE - GLASS/COTTON/FILM

ADHESIVE TAPE ADHESIVES

When selecting a tape for the application, the type of adhesive that the tape uses must be considered. Each type of adhesive has properties that make it a better choice for various applications. Rubber based adhesives are the most electrically pure and are not electrically corrosive but can withstand temperature up to 130°C. Acrylic adhesives offer good initial solvent resistance and an operating temperature up to 155°C. Silicone adhesive systems apply well at low or high temperatures, and have good solvent resistance, and operate up 180°C+. The characteristics of each type of adhesive is enhanced when cured with heat.



GLASS TAPES



From 3M two choices are offered in high temperature glass tapes.

27 CLASS B (130°C)

Conformable, abrasion resistant. For use as coil wrap layer insulation and connection insulation. Rubber thermosetting adhesive. 7 mil thick, 3000 volt dielectric.

WIDTH (IN.)	PART NUMBER
1/4	3M-27-1/4
1/2	3M-27-1/2
3/4	3M-27-3/4
1	3M-27-1
1-1/2	3M-27-1-1/2

69 CLASS H (180°C)

Conformable, edge tear resistant. For use as coil wrap layer insulation and connection insulation. Silicone thermosetting adhesive. 7.5 mil thick, 3500 volt dielectric.

WIDTH (IN.)	PART NUMBER
1/4	3M-69-1/4
1/2	3M-69-1/2
3/4	3M-69-3/4
1	3M-69-1
1-1/2	3M-69-1-1/2
2	3M-69-2

From PermaceL two choices are offered in high temperature glass tapes.

21 CLASS F (155°C)

A versatile tape with excellent conformability. For use as a coil wrap or lead insulation. Rubber thermosetting adhesive. 7 mil thick, 2500 volt dielectric.

WIDTH (IN.)	PART NUMBER
1/4	P-21-1/4
1/2	P-21-1/2
3/4	P-21-3/4
1	P-21-1
1-1/2	P-21-1-1/2

212 CLASS H (200°C)

Superior conformability, and excellent solvent resistance and flame retardance. For use as coil wrap, layer and lead insulation. 5 mil thick silicone adhesive. 3500 volt dielectric.

WIDTH (IN.)	PART NUMBER
1/4	P-212-1/4
1/2	P-212-1/2
3/4	P-212-3/4
1	P-212-1
1-1/2	P-212-1-1/2

PAPER/FILM TAPE

#248 CLASS A (105°C)

A laminate of polyester film and paper that is especially suited for taping connections, anchoring leads, and phase insulation. Rubber thermosetting adhesive. 6 mil thick. 5000 volt dielectric.



WIDTH (IN.)	PART NUMBER
1/4	P-248-1/4
1/2	P-248-1/2
3/4	P-248-3/4
1	P-248-1
1-1/4	P-248-1-1/4
1-1/2	P-248-1-1/2

#29 CLASS A (105°C)

A conformable cotton tape with good tensile strength and is puncture and abrasion resistant. Perfect for applications requiring good mechanical strength. Used for coil wrapping and lead connections. 9.5 mils thick with rubber thermosetting adhesive. 2000 volt dielectric strength.



WIDTH (IN.)	PART NUMBER
1/4	3M-29-1/4
1/2	3M-29-1/2
3/4	3M-29-3/4
1	3M-29-1
1-1/2	3M-29-1-1/2
2	3M-29-2

#201 CLASS A (105°C)

Toughness, conformability and high reliability characterize this tape. It offers high absorbency with superior adhesion. This economical high strength tape is used for wrapping coils and connections. Rubber thermosetting adhesive. 10.5 mils thick with 2500 volt dielectric strength.



WIDTH (IN.)	PART NUMBER
1/4	P-201-1/4
1/2	P-201-1/2
3/4	P-201-3/4
1	P-201-1
1-1/2	P-201-1-1/2

GLASS REINFORCED FILM TAPE

#46 CLASS B (130°C)

A strong tape with good edge tear resistance. Perfect for taping coil ends and reinforcing insulation for electrical and mechanical strength. Rubber thermosetting adhesive. 6.5 mil thick, 5000 volt dielectric.



WIDTH (IN.)	PART NUMBER
1/4	3M-46-1/4
1/2	3M-46-1/2
3/4	3M-46-3/4
1	3M-46-1

#247 Class F (155°C)

Outstanding resistance to solvents and mineral oils. High tensile strength makes this a perfect choice for taping end turns and reinforcing insulation. Acrylic thermosetting adhesive 6.5 mil thick, 500 volt dielectric.



WIDTH (IN.)	PART NUMBER
1/4	P-247-1/4
1/2	P-247-1/2
3/4	P-247-3/4
1	P-247-1

ADHESIVE TAPE - VINYL/MASKING/GUIDE LINE/SPLICING

VINYL TAPE

3M VINYL TAPES

Super 33+ premium quality vinyl tape, Stickier, stretchier and highly conformable. This 7 mil tape applies well from 0°F to 220°F. It is flame

retardant and resists UV rays, abrasion, moisture, alkalis, acids and corrosion. For use as a primary insulation up to

600V. UL and CSA listed. Super 88 Premium quality vinyl tape remains conformable even on the coldest days. 8.5 mil thick this tape provides added electrical properties and quicker build up. Operates well from 0°F to 220°F Meets MIL-I-24391, UL & CSA listed.



WIDTH (IN.)	LENGTH	PART NUMBER
3/4	66 foot	3M-33-3/4-66FT
1-1/2	36 yard	3M-33-1-1/2X36
2	36 yard	3M-33-2X36YD
3/4	66 foot	3M-88-3/4-66FT
1-1/2	36 yard	3M-88-1-1/2

3M COLOR CODING TAPE



3M #35 Vinyl Electrical Color Coding Tape is a 7 mil electrical grade tape with a pressure sensitive adhesive. Available in

nine fade resistant colors for job identification and safety uses. UL and CSA rated. Colors available are: Red, Yellow, Blue, Brown, Gray, White, Green, Orange, Violet.

WIDTH (IN.)	LENGTH	PART NUMBER
1/2	20 feet	3M-35-1/2-**
3/4	66 feet	3M-35-***-3/4x66FT
3/4	36 yard	3M-35-***-3/4x36YD

** & *** Insert Color

3M #200

Tartan 200 masking tape is a utility purpose tape for holding bundling, sealing, non-critical masking and vast number of other jobs where a pressure sensitive tape is required.

Normally used at room temperature, but will last at temperatures up to 150°F for one hour. Not for outdoor use. 5.5 mil thick. 60 yard rolls.

WIDTH (IN.)	PART NUMBER
1/2	3M-200-1/2
3/4	3M-200-3/4
1	3M-200-1
2	3M-200-2

GUIDE LINE

TRIANGULAR GUIDE LINE TAPE

A silicone rubber tape that is extremely conformable for wrapping lead connections.

Assures a smooth void free wrap over difficult shapes. It is self adhering and self-fusing, curing in 24 hours at room temperature. Faster curing and a harder finish can be accomplished with the application of heat after wrapping. The colored guideline provides an easy method of performing half-lap wrapping. Up to 400 volts/mil dielectric. Temperature range -60°C to 200°C. 12 yard rolls. Meets mil spec MIL-I-46852B Type II. Red color. Other

thicknesses, widths, and colors are available. See your Essex Brownell representative.

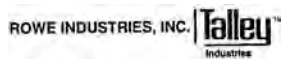

THICK (IN.)	LENGTH (IN.)	PART NUMBER
.020	1	TGL-1-020
.030	1	TGL-1-030
.040	1	TGL-1-040

PERMACEL VINYL TAPES

P-22 is an economy grade, vinyl plastic insulating tape. This 7 mil tape was developed for use where a good quality, economical UL listed tape is required. Meets HH-I-595C.

P-28AW is an 8.5 mil heavy duty vinyl backed tape with a special plasticizer formulation that allows the tape to stretch and conform easily, even in cold temperatures. Is UL and CSA approved, flame retardant, and cold weather-resistant.



PART NUMBERS	
P-22-3/4	
P-28AW-3/4X66FT	
P-28AW-3/4X108FT	
Tapes are supplied on 1" cores	
Other widths available. See your Essex Brownell Representative	

PERMACEL MARKING TAPE

Permacel #32 Vinyl Marking tape consists of a 6 mil vinyl film with natural rubber adhesive. Available in 13 colors and used for color coding, floor marking, moisture sealing, identification, duct sealing and masking of printed circuit boards. Meets PPP-T-66E Type 1 Class II; A-A-1689B. Colors available are: Black, Brown, Clear, Gray, Dark Blue, Dark Green, Lt. Blue, Lt. Green, Orange, Purple, Red, White, Yellow. Tape is supplied on 36 yard rolls with 3" cores.

WIDTH (IN.)	PART NUMBER
1	P-32-1-***
2	P-32-2-***
3	P-32-3-***

*** Insert Color

MASKING TAPE

PERMACEL #791

Outstanding value!! P-791 provides the proper blend of performance and price. For room temperature paint masking and light duty packaging applications. 5 mil thick. 60 yard rolls.



WIDTH (IN.)	PART NUMBER
1/2	P-791-1/2
3/4	P-791-3/4
1	P-791-1
1-1/2	P-791-1-1/2
2	P-791-2

SPLICING

3M LINERLESS SPLICING TAPE

An EPR based rubber tape for insulating splices and terminal in connections. Rated for 90°C continuous use, with short-term 130° overload capability. This tape will provide an effective moisture seal with void-free buildups. Suitable for use on up to 69 Kv applications. Aids in thermal dissipation of splice heat and is flame retardant. 30 foot rolls. Black color.

WIDTH (IN.)	PART NUMBER
3/4	3M-130C-3/4X30
1	3M-130C-1X30
1-1/2	3M-130C-1-1/2X30
2	3M-130C-2X30



DOW CORNING FOR ELECTRIC MOTOR APPLICATION

44 HIGH TEMPERATURE BEARING GREASE

Excellent product to lubricate bearings operating at extreme high temperatures. Temperature range -40° to 400°F.

CONTAINER	PART NUMBER
5.3 oz. Tube	DC-44-*5.3
14.1 oz. Cart.	DC-44-14.1
8 lb.	DC-44-*8
40 lb. Pail	DC-44-*40
* Medium Grade-MED; Light Grade-LT	

748 NONCORROSIVE SEALANT

Ideal for form-in place gaskets to seal electrical components. Noncorrosive (alcohol) cure; adheres to most metals, plastics, masonry and other surfaces. Temperature range -65° to 350°F.

CONTAINER	PART NUMBER
10.1 oz. Cart.	DC-748-10.3
4.5 gal. Pail	DC-748-4.5

BR-2 PLUS MULTI-PURPOSE E.P. GREASE

Economical product to lubricate bearings operating under a more limited temperature range. A good low cost grease with MoS_2 . Temperature range -20° to 265°F.

CONTAINER	PART NUMBER
14.1 oz.	DC-BR2-PLUS-14.1
35 lb. Pail	DC-BR2-PLUS-35

BG-20 HIGH PERFORMANCE SYNTHETIC GREASE

Excellent product to lubricate bearings operating under a wide range of conditions, including high speeds, extreme temperatures and high loads. Temperature range -50° to 360°F.

CONTAINER	PART NUMBER
5.3 oz. Tube	DC-BG20-5.3
14.1 oz. Cart.	DC-BG20-14.1
40 lb. Pail	DC-BG20-40

METAL PROTECTIVE COATING

This product is used to protect motor shafts and metal parts from corrosion. Extremely resistant to corrosive or salty environments; transparent with good inherent lubricating properties. Temperature range -40° to 150°F.

CONTAINER	PART NUMBER
10 oz. Aerosol	DC-MET-PROT-10OZ
30 lb. Pail	DC-MET-PROT-30

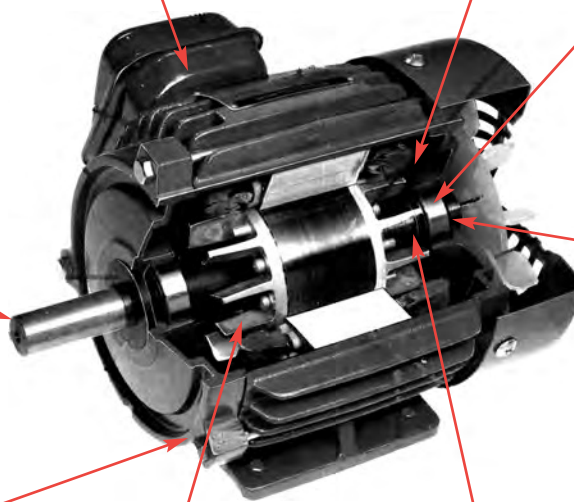

41 EXTREME HIGH TEMPERATURE BEARING GREASE

Excellent product to lubricate ball bearings operating at extreme high temperatures. Temperature range 0° to 550°F.

CONTAINER	PART NUMBER
5.3 oz. Tube	DC-41-5.3
14.1 oz. Cart.	DC-41-14.1
8 lb. Pail	DC-41-8
40 lb. Pail	DC-41-40

1000 ANTISEIZE PASTE

Premium multi-purpose anti-seize for threaded connections. Eases assembly and provides for non-destructive disassembly. Not recommended for use in grease guns or high pressure systems. It is a brown mineral oil-based paste which contains solid lubricants.

CONTAINER	PART NUMBER
1 lb.	DC-1000-1LB

1890 PROTECTIVE COATING

Excellent moisture protection and is resistant to dust, sand and dirt particles. Adds protection to motor windings. Temperature range -65° to 350°F.

CONTAINER	PART NUMBER
1 gal. Pail	DC-1890-1
4.5 gal. Pail	DC-1890-4.5

3451 CHEMICAL RESISTANT BEARING GREASE

Excellent for lubricating bearings exposed to harsh chemical environments. Temperature range -40 to 450°F.

CONTAINER	PART NUMBER
3 oz. Tube	DC-3451-3
19.4 oz. Cart.	DC-3451-19.4
10 lb. Pail	DC-3451-10
40 lb. Pail	DC-3451-40

33 EXTREME LOW TEMPERATURE BEARING GREASE

Excellent product to lubricate bearings operating at extreme low temperatures. Temperature range -100° to 355°F.

CONTAINER	PART NUMBER
5.3 oz. Tube	DC-33-*5.3
14.1 oz. Cart.	DC-33-*14.1
8 lb. Pail	DC-33-*8
40 lb. Pail	DC-33-*40
* Medium grade- MED; Light Grade-LT	

MOLY PENE-LUBE

Contains MoS_2 for improved disassembly and load handling; penetrates rust; displaces water; retards corrosion. Temperature range -20° to 120°F.

CONTAINER	PART NUMBER
16 oz. Spray	DC-MLY-PENE-LUBE-16
5 Gallon	DC-MLY-PENE-LUBE-5

WORM GEAR SPEED REDUCER APPLICATIONS

55 O-RING LUBRICANT

Dynamic lubricant between rubber and metal parts. Slightly swells O-Ring to provide a tight seal; wide temperature range; resists oxidation. Temperature range -85° to 350°F. Not recommended for silicone rubber O-rings and seals.

CONTAINER	PART NUMBER
5.3 oz. Tube	DC-55-5.3
8 lb.	DC-55-8
40 lb.	DC-55-40

PENE-LUBE

Multi-purpose penetrating lubricant for loosening rusted parts, stopping squeaks; short term corrosion protection; water displacement. Temperature range -20° to 120°F.

CONTAINER	PART NUMBER
12 oz. Aerosol	DC-PENE-LUB-12
16 oz. Spray	DC-PENE-LUBE-16OZ
1 Gallon	DC-PENE-LUBE-1

G-n METAL ASSEMBLY

Excellent for breaking in bearings, splines, gears, cams, chains, conveyer tracks. Reduces friction and wear on parts during assembly and breaking-in. Gray black paste or spray.

CONTAINER	PART NUMBER
11 oz. Aerosol	DC-GN-S-11
2.8 oz. Tube	DC-GN-2.8
Pint	DC-GN-17.6
10 lb.	DC-GN-10
50 lb.	DC-GN-50

1000 ANTISEIZE PASTE

Premium multi-purpose anti-seize paste for threaded connections. Eases assembly and provides for non-destructive disassembly. Not recommended for use in grease guns or high pressure systems. It is a brown mineral oil-based paste which contains solid lubricants.

CONTAINER	PART NUMBER
1 lb.	DC-1000-1LB

M GEAR OIL ADDITIVE

Industrial gear oil additive; reduces friction in gear boxes; reduces wear and lowers operating temperatures. High load carrying capacity at slow to moderate speeds. Compatible with most petroleum oils used in gear boxes. Add up to 10% of additive. Temperature range 0° to 250°F.

CONTAINER	PART NUMBER
Quart	DC-M-GEAR-1QT
5 Gallon	DC-M-GEAR-5GAL

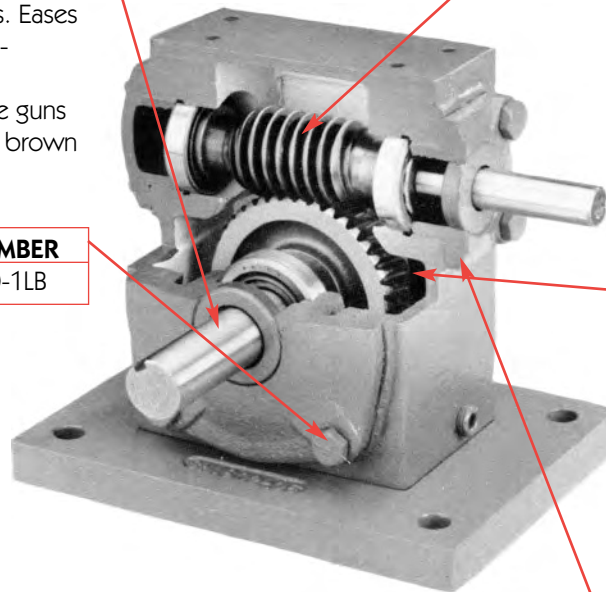

MOLY PENE-LUBE

Contains MoS₂ for improved disassembly and load handling; penetrates rust; displaces water; retards corrosion. Temperature range -20° to 120°F.

CONTAINER	PART NUMBER
16 oz. Spray	DC-MLY-PENE-LUBE-16
5 Gallon	DC-MLY-PENE-LUBE-5

735 OIL-RESISTANT SEALANT

Ideal for form-in place gaskets to seal gearbox components. Resistant to most common oils and lubricants. A one part non slumping RTV paste; cures at room temperature on exposure to moisture in air to a tough rubbery, black solid. Temperature range -80° to 400°F.

CONTAINER	PART NUMBER
10.1 oz. Cartridge	DC-735-10.3

PUMP APPLICATIONS

832 MULTI-SURFACE ADHESIVE SEALANT

Ideal for form-in place gaskets. Non-corrosive (alcohol) cure; adheres to most metals, glass, masonry and other surfaces. Temperature range -65° to 300°F.

CONTAINER	PART NUMBER
10.1 oz. Cartridge	DC-832-GRY-10.3
10.1 oz. Cartridge	DC-832-WHT-10.3
4.5 Gallon Pail	DC-832-GRY-4.5

1000 ANTISEIZE PASTE

Premium multi-purpose, anti-seize paste for threaded connections. Eases assembly and provides for non-destructive disassembly. Not recommended for use in grease guns or high pressure systems. A brown mineral oil-based paste which contains solid lubricants.

CONTAINER	PART NUMBER
1 lb.	DC-1000-1LB

111 VALVE LUBRICANT & SEALANT

General purpose O-Ring and Valve lubricant. Provides a noncuring moisture barrier; high dielectric strength. Temperature range -40° to 400°F.

CONTAINER	PART NUMBER
5.3 oz. Tube	DC-111-5.3
14.1 oz. Cartridge	DC-111-14.1
8 lb.	DC-111-8
40 lb.	DC-111-40

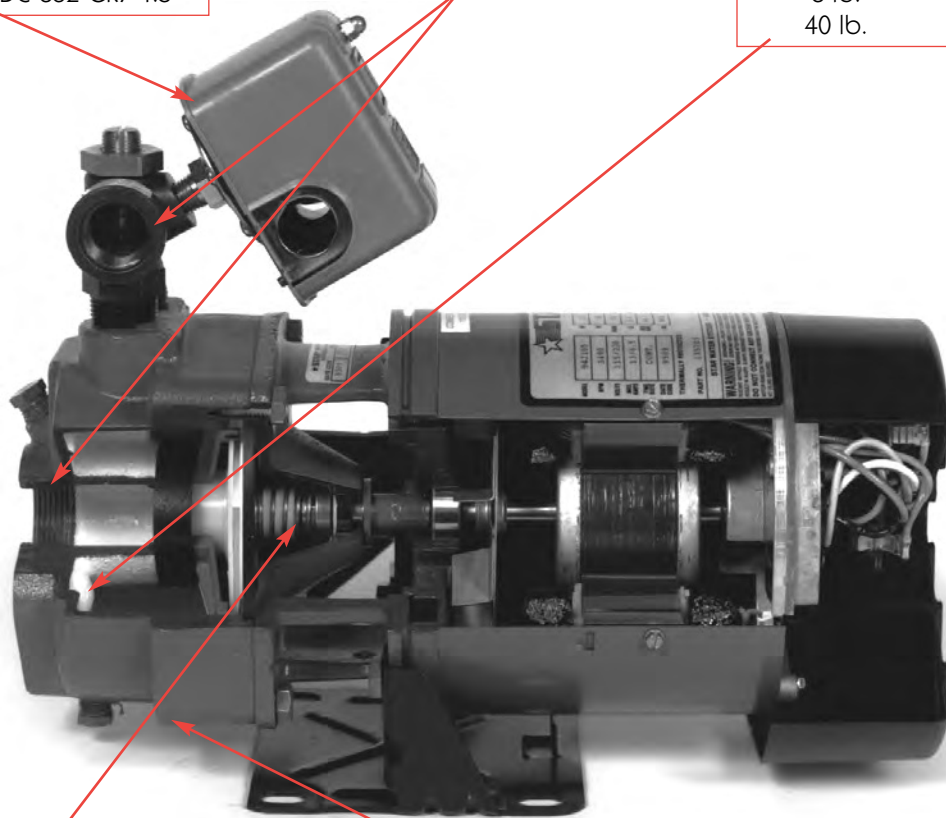

BG-20 HIGH PERFORMANCE SYNTHETIC GREASE

Excellent product to lubricate bearings operating under a wide range of

CONTAINER	PART NUMBER
5.3 oz. Tube	DC-BG20-5.3
14.1 oz. Cartridge	DC-BG20-14.1
40 lb. Pail	DC-BG20-40

conditions, including high speeds, extreme temperatures and high loads. Temperature range -50° to 360°F.

55 O-RING LUBRICANT

Dynamic lubricant between rubber and metal parts. Slightly swells O-Ring to provide

CONTAINER	PART NUMBER
5.3 oz. Tube	DC-55-5.3
8 lb.	DC-55-8
40 lb.	DC-55-40

a tight seal; wide temperature range; resists oxidation. Temperature range is -85° to 350°F. Not recommended for silicone rubber O-rings and seals.

PERMABOND

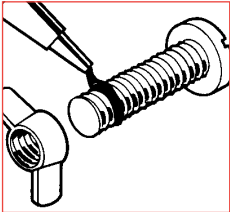

GENERAL PURPOSE THREAD LOCKER

PERMA-LOK

TYPICAL USES	PRODUCT FEATURES	TECHNICAL DATA	PART NUMBER
Replaces lockwashers	Meets 80% of all nut and bolt threadlocking applications Thixotropic for easy application	Fixture time 20 minutes	MM-115-50-ML
Replaces plastic insert fasteners		Full cure time 24 hours	
Replaces interference fits and jam nuts		Maximum gap fill 0.006 "(0.150mm)	MM-115-250-ML
		Torque strength 100 in-lb.	
		Shear strength 1500 psi	

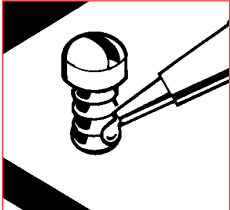

WICKING GRADE THREAD LOCKER

PERMA-LOK

TYPICAL USES	PRODUCT FEATURES	TECHNICAL DATA	PART NUMBER
Locking pre-assembled parts	Low viscosity penetrating formula No disassembly	Fixture time 15 minutes	HL-126-50-ML
Augments press fits		Maximum gap fill 0.005 "(0.130mm)	HL-126-250-ML
Seal weld porosities		Shear strength 1500 psi	

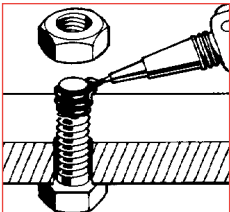

PERMANENT THREAD LOCKER

PERMA-LOK

TYPICAL USES	PRODUCT FEATURES	TECHNICAL DATA	PART NUMBER
Fastens on vibrating machines	High strength, permanent and eliminates need for doublenutting or welding Prevents corrosion and leakage	Fixture time 20 minutes	HM-128-50-ML
Valve Sets		Full cure time 24 hours	HM-128-250-ML
		Maximum gap fill 0.008 "(0.20mm)	
		Torque strength 250 in-lb.	
		Shear strength 2500 psi	

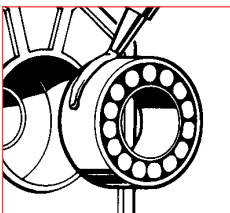

PERMANENT RETAINER

PERMA-LOK

TYPICAL USES	PRODUCT FEATURES	TECHNICAL DATA	PART NUMBER
Bearings in electric motors	Outperforms shrink or press fit parts Excellent temperature resistance	Fixture time 20 minutes	HM-160-50-ML
High temperature retaining applications		Full cure time 16 hours	HM-160-250-ML
		Maximum gap fill 0.008 "(0.20mm)	
		Torque strength 250 in-lb.	
		Shear strength 3000 psi	

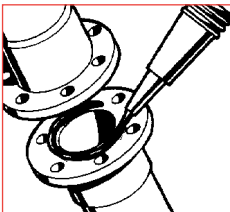

GASKETMAKER

PERMA-LOK

TYPICAL USES	PRODUCT FEATURES	TECHNICAL DATA	PART NUMBER
Water pumps	Remains flexible Excellent temperature resistance Excellent resistance to various solvents	Fixture time one hour	HH-190-50-ML
Gearbox covers		Full cure time 24 hours	HH-190-300-ML
		Maximum gap fill 0.025 "(.635mm)	
		Torque strength 65 in-lb.	
		Shear strength 900 psi	

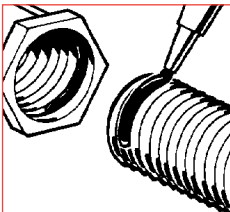

GENERAL PURPOSE PIPE SEALANT (low strength-high viscosity)

PERMA-LOK

TYPICAL USES	PRODUCT FEATURES	TECHNICAL DATA	PART NUMBER
Threaded pipe joints	Seals pipes joints to 1000 PSI instantly Seals in excess of 10,000 PSI UL approved	Fixture time two hours	LH-050-50-ML
Hydraulic and Pneumatic fittings		Full cure time 16 hours	LH-050-250-ML
		Maximum gap fill 0.020 (.510mm)	
		Torque strength 35 in. lb.	
		Shear strength 1000 psi	

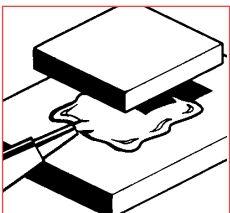

MULTI-SURFACE CYANOACRYLATE (medium viscosity fast cure)

PERMABOND

TYPICAL USES	PRODUCT FEATURES	TECHNICAL DATA	PART NUMBER
Bonds most rubbers and plastics	Excellent gap filling capability Excellent flow control	Fixture time 15 seconds	PERM-268-1-OZ
Gasket and seal bonding		Full cure time 4 hours	PERM-268-1-LB
		Maximum gap fill 0.017 (0.430mm)	
		Shear strength 1800 psi	

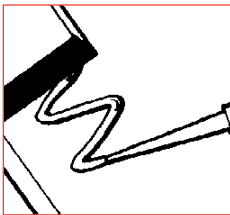

METAL BONDING CYANOACRYLATE		PERMABOND	
TYPICAL USES	PRODUCT FEATURES	TECHNICAL DATA	PART NUMBER
Metal to metal and rubber	Excellent for bonding-metal to metal Low viscosity	Fixture time 15 seconds Full cure time 4 hours Maximum gap fill 0.005 (0.130mm) Shear strength 3000 psi	PERM-910-3-GR PERM-910-1-OZ PERM-910-1-LB

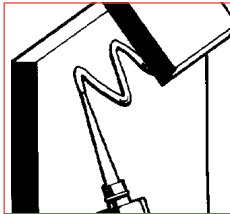

NON-DRIP CYANOACRYLATE		PERMABOND	
TYPICAL USES	PRODUCT FEATURES	TECHNICAL DATA	PART NUMBER
For use on vertical applications For bonding most metals, plastics and rubber	Non-drip rheology formula Excellent for use on porous surfaces	Fixture time 30 seconds Full cure time 4 hours Maximum gap fill 0.025 (0.130mm) Shear strength 2000 psi	PERM-2010-1-OZ PERM-2010-1-LB

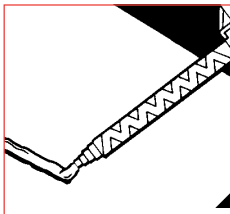

RAPID EPOXY REPAIR (FAST CURE)		PERMABOND	
TYPICAL USES	PRODUCT FEATURES	TECHNICAL DATA	PART NUMBER
For rapid repair of maintenance items such as metals, plastics, glass and other porous ceramics	Rapid cure rate Easily dispensed Excellent gap filling capabilities	Fixture time 5 minutes Full cure time 1 hours Maximum gap fill 0.20 (5.1mm) Shear strength 700 psi	PERM-E01-50ML

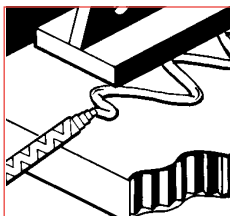

TOUGHENED EPOXY (STRUCTURAL BONDING)		PERMABOND	
TYPICAL USES	PRODUCT FEATURES	TECHNICAL DATA	PART NUMBER
For use in general structural bonding of metals and plastics	Rapid cure rate Excellent gap filling capabilities	Fixture time 2 hour Full cure time 24 hours Maximum gap fill 0.20 (5.1mm) Shear strength 3000 psi	PERM-E04-50ML

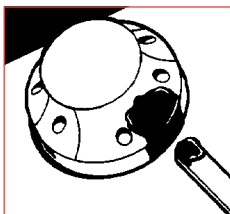

FE RAPID (EMERGENCY METAL REPAIR)		PERMABOND	
TYPICAL USES	PRODUCT FEATURES	TECHNICAL DATA	PART NUMBER
Seals cracks in metals Internal bores of pipes, valves and fittings	Fast cure time reduces down time Excellent gap filling capabilities	Fixture time 3 hours Full cure time 6 hours Maximum gap fill 0.20 (5.1mm)	PERM-FE-RAP-400ML

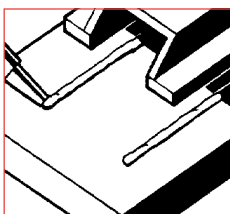

TOUGHEN ACRYLIC (FAST CURE)		PERMABOND	
TYPICAL USES	PRODUCT FEATURES	TECHNICAL DATA	PART NUMBER
Provides strong bond to wood, plastic, glass and metal	Excellent resistance to harsh environments No pre-cleaning of oily metals required	Fixture time 2 minutes Full cure time 4 hours Maximum gap fill 0.25 (5.1mm) Shear strength 4,000 psi	PERM-F246-50ML

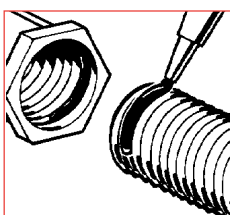

ANTI-SEIZE (METAL CORROSION PREVENTION)		PERMABOND	
TYPICAL USES	PRODUCT FEATURES	TECHNICAL DATA	PART NUMBER
For use on metal parts to prevent corrosion Aids in assembly by preventing galling	Forms a protective film which cannot be burned off Resistant to salt water and other harsh environments	Remains flexible Recommended thickness 0.40 (10.2mm)	PERM-ANTISEIZE-1

MISCELLANEOUS - SEALANTS

CHICO COMPOUND

A water soluble powder that forms a seal around each conductor and restricts the passage of gases, vapors, or flames through the fitting. When mixed with water, it makes a compound that is easily poured into the terminal box or conduit. The compound expands slightly when curing and bonds to the inner walls of the box. Cure time is approx. 60-70 minutes. Chico X fiber is used to form a dam to prevent the compound from running out when poured into the box. Suitable for explosion proof motors.

DESCRIPTION	PART NUMBER
Fiber 1 lb.	CHI X
5 lb. Can	CHI 5

SCOTCHKOTE

3M Scotchkote electrical coating provides additional protection against moisture and oil. It's used as a top coat for splices and insulation that is exposed to adverse weathering. Once the connection has been insulated, apply Scotchkote to provide a tough oil resistant coating over the insulation. Supplied in 15 oz. brush top can.



PART NUMBER	3M-SCKOTE

NON-CORROSIVE SEALANT

Dow Corning 748 is a non corrosive and non conductive adhesive sealant especially designed for electrical applications. DC-748 does not release the vinegar odor during cure and is not corrosive to most metals. Perfect for sealing terminal boxes, bonding the silicone rubber caps to connections. White in color. DC-748 has a range of -65° to 350°F.



SIZE	PART NUMBER
4.7 oz. Tube	DC-748-3
10.1 oz. Cartridge	DC-748-10.3

ROCKITE

A cement type material that expands as it cures. When mixed with water to a pourable consistency, it flows and seeps into place as if it were molten lava. Initial set takes place in about 25 minutes, and develops compression strength of about 4500 lbs. in one hour. The compound does not contain Portland cement, ferrous materials or rust promoting agents. Great for filling and sealing conduit boxes.

SIZE	PART NUMBER
1 lb.	ROCKITE-1LB
5 lb.	ROCKITE-5LB
10 lb.	ROCKITE-10LB
50 lb.	ROCKITE-50LB

DIELECTRIC TRANSFORMER FLUID

Dow Corning 561 dielectric fluid combines a unique combination of dependable safety features and high performance characteristics. Use of 561 allows liquid design transformers to be used indoors and close to buildings where other fluids may pose a fire hazard. Listed by Factory Mutual for use without additional fire protection. 561 is also the least hazardous of all known transformer fluids. 561 is not classified as hazardous under the RCRA.

SIZE	PART NUMBER
5 Gallon	DC-561-40
55 Gallon	DC-561-440

HIGH TEMPERATURE SEALANT

Dow Corning 736 sealant is the answer when the product will be exposed to high temperatures. An operating temperature range of -85° to 500°F, and ability to withstand intermittent temperatures of 600°F, makes this product an excellent choice for bonding space heaters in place. Red in color.



SIZE	PART NUMBER
3 oz. Tube	DC-736-3
10.3 oz. Tube	DC-736-10.3ST
10.1 oz. Cartridge	DC-736-10.3

DUCT SEAL

Duct seal is an asbestos free compound that is permanently soft, non-toxic and will adhere to most clean dry surfaces. Duct seal will not adversely affect plastic materials or corrode metals. Used to seal around junction boxes and lead entrances in the stator shell. Temperature range -30° to 175°F. Unlimited shelf life.

SIZE	PART NUMBER
1 lb.	DUCT SEAL
5 lb.	DUCT SEAL 5

VANGUARD BALANCING COMPOUND

Vanguard balancing compounds is available in two styles. The VBC-22 is more moist than the VBC-21. Both products are chemical-resistant and operate at temperatures from -80° to 500°F. Two part compound is light gray in color when mixed and has approximately 3 hour pot life. Shelf life is approximately 1 year. Both materials can be applied for test balancing and then cured in an oven or with a heat gun for normal use.

SIZE	PART NUMBER
2 lb.	VBC-21-2
15 lb.	VBC-21-15
2 lb.	VBC-22-2
15 lb.	VBC-22-15

PREMIUM ADHESIVE SEALANT

A Dow Corning one part non-slumping paste that cures at room temperature to a tough rubbery solid. This multi-purpose silicone sealant can be used in a number of bonding and sealing applications (bonding nameplates, form in place gaskets, etc.). Temperature range -75° to 350°F. Utilizes an acidic acid cure which may cause corrosion on some metals. Available in Clear (CLR), White (WHT), Black (BLK), and Aluminum (ALUM).

SIZE	PART NUMBER
4.7 oz. Tube	DC-732-***-4.7
10.3 oz. Tube	DC-732-***-10.3ST
10.1 oz. Cartridge	DC-732-***-10.3
*** Insert color code	

MISCELLANEOUS - ADHESIVES

MIX AND FIX EPOXY KIT

A convenient foolproof method of using epoxy adhesives. Each kit contains 10 pre-measured packets and mixing cards for perfect mixing every time. Fixturing in 5 minutes. Keep some in your toolbox for those times when you'll need it! Works well on plastics, metal, wood, glass, ceramic, stone, or almost any surface. Simply tear open the packets, squeeze onto the mixing card mix and apply!



PART NUMBER PERM-MF-KIT

DOLPH EPOXY KITS

Waterproof, non-metallic, non-magnetic, insulating epoxies packaged in double tube kits. Each tube has an opening sized to help measure the mixing ratio. Just squeeze out the same lengths of each part.



HYSOL[§] EPOXY KITS

Undivided attention to quality is what sets HYSOL[§] epoxy kits apart from the rest. Superior manufacturing techniques and testing procedures assure a quality product time after time. Packaged in 2 tube kits that are metered to dispense the right mixing ratio.



BOSTIK^{††} EPOXY KITS

Packaged in a convenient double tube dispenser, these kits are designed to be dispensed with the BOSTIK^{††} dispensing gun. With a squeeze of the trigger the epoxy is precisely metered out and mixed.



EPOXY ADHESIVE SELECTION CHART

APPLICATION	MFR.	POT LIFE	HARDNESS		MIXED	VISCOSITY	COLOR	PART NUMBER
			CURE TIME	TEMP RANGE				
General Purpose	Bostik	30 Min.	24 Hrs.	80	-60° to 210°F	40,000-55,000	Green	BST-7538-2OZ
5 Minute Curing	Bostik	5-7 Min.	1 Hr.	75	-60° to 185°F	12,000-16,000	Clear	BST-7575-CLR-2OZ
5 Minute Curing	Bostik	5-7 Min.	1 Hr.	75	-60° to 185°F	12,000-16,000	Gray	BST-7575-GRY-2OZ
General Purpose	Hysol	20 Min.	24 Hrs.		-50° to 300°F	Paste	White	HYSOL-1C-KIT
Quick Set	Hysol	3 Min.	24 Min.		-50° to 125°F	Light Paste	Clear	HYSOL-608-KIT
Optically Clear	Hysol	45 Min.	36 Hrs.		-50° to 180°F	Light Paste	Clear	HYSOL-0151-KIT
Aluminum Filled	Hysol	30 Min.	24 Hrs.		-50° to 300°F	Paste	Alum.	HYSOL-6C-KIT
Fast Cure	Dolph	15 Min.	16 Hrs.	75-80		Paste	Clear	CN-1065
General Purpose	Dolph	2-4 Hrs.	24 Hrs.	70-75		Paste	Red	DECK 180 TUBE
Metal Repair	Permabond		6 Hrs.			Paste	Black	PERM-FE-RAPID-400ML
Rapid Repair	Permabond		1 Hr.			2 Part		PERM-E01-50ML
Tougten Epoxy	Permabond		24Hrs			2 Part		PERM-E04-50ML

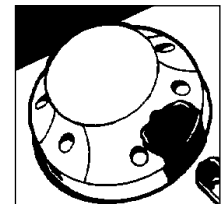
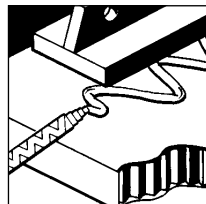
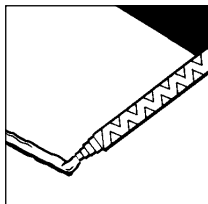

§ Hysol is a registered trademark of The Dexter Corporation.
 †† Bostik is a registered trademark of Bostik Corporation.

MISCELLANEOUS - WIRE MARKERS

SCOTCHCODE WIRE MARKER TAPE

This convenient wire marking system uses a compact refillable dispenser. The individual compartments allows you to customize the dispenser to the letter/number/color combination required. Order the dispenser filled with numbers (0-9) or colors, or order the dispenser empty, then get the refills needed. Tape rolls are .215" wide x 8 feet long.



PART #	LEGEND	LEGEND	PART #	LEGEND	PART #	LEGEND	PART #
STD	Dispenser	20-29	SDR-20-29	N	SDR-N	Brown	SDR-BN
STD-0-9	Filled 0-9	30-39	SDR-30-39	O	SDR-O	Green	SDR-GN
STD-C	Filled Colors	A	SDR-A	P	SDR-P	Gray	SDR-GY
SDR-0	0	B	SDR-B	Q	SDR-Q	Orange	SDR-OR
SDR-1	1	C	SDR-C	R	SDR-R	Red	SDR-RD
SDR-2	2	D	SDR-D	S	SDR-S	Violet	SDR-VL
SDR-3	3	E	SDR-E	T	SDR-T	White	SDR-WH
SDR-4	4	F	SDR-F	U	SDR-U	Yellow	SDR-YL
SDR-5	5	G	SDR-G	V	SDR-V	L1	SDR-L1
SDR-6	6	H	SDR-H	W	SDR-W	L2	SDR-L2
SDR-7	7	I	SDR-I	X	SDR-X	L3	SDR-L3
SDR-8	8	J	SDR-J	Y	SDR-Y	T1	SDR-T1
SDR-9	9	K	SDR-K	Z	SDR-Z	T2	SDR-T2

BRADY CLOTH MARKERS

A general purpose vinyl cloth marker exhibiting high adhesion properties. Moderately resistant to heat oil and dirt. Temperature range -40° to 180°F. Each card contains 36 markers 1-1/2" long. Consecutive numbers on each card. 25 cards per box.



LEGEND	PART NUMBER
0	QL-0
1	QL-1
2	QL-2
3	QL-3
4	QL-4
5	QL-5
6	QL-6
7	QL-7
8	QL-8
9	QL-9
1-9	QL-1-9
1-33	QL-1-33

Other number combinations and colors are available. Call your Essex Brownell Representative.

BRADY FOIL MARKERS

Dead soft aluminum foil with good conformability. Resistant to heat, oil and solvents and abrasion resistant. Temperature range -40° to 266°F. 25 cards per box.



LEGEND	PART NUMBER
0	QL-AF-0
1	QL-AF-1
2	QL-AF-2
3	QL-AF-3
4	QL-AF-4
5	QL-AF-5
6	QL-AF-6
7	QL-AF-7
8	QL-AF-8
9	QL-AF-9
1-9	QL-AF-1-9
1-33	QL-AF-1-33

Other number combinations and colors are available. Call your Essex Brownell Representative.

ALUMINUM WIRE MARKERS

Made from .016" thick soft aluminum, these tags are designed to last throughout the most adverse conditions. Available in three sizes and packaged in packs of 100. They are an effective economical method of identifying motor leads.

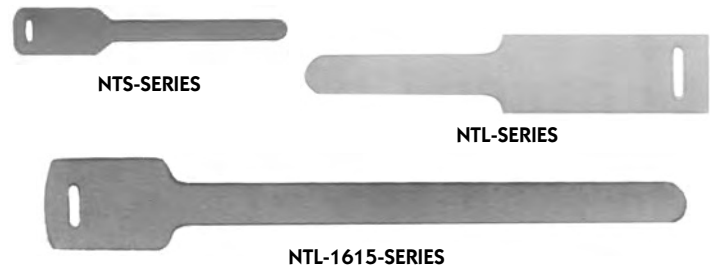

LEGEND	NTL 1615 PART NUMBER	NTS PART NUMBER	NTL PART NUMBER	LEGEND	NTL 1615 PART NUMBER	NTS PART NUMBER	LEGEND	NTL 1615 PART NUMBER	NTS PART NUMBER
0	NTL-1615-0	NTS-0	NTL-0	10	NTL-1615-10	NTS-10	F3	NTL-1615-F3	NTS-F3
1	NTL-1615-1	NTS-1	NTL-1	11	NTL-1615-11	NTS-11	F4	NTL-1615-F4	NTS-F4
2	NTL-1615-2	NTS-2	NTL-2	12	NTL-1615-12	NTS-12	S1	NTL-1615-S1	NTS-S1
3	NTL-1615-3	NTS-3	NTL-3	13	NTL-1615-13	NTS-13	S2	NTL-1615-S2	NTS-S2
4	NTL-1615-4	NTS-4	NTL-4	A1	NTL-1615-A1	NTS-A1	S3	NTL-1615-S3	NTS-S3
5	NTL-1615-5	NTS-5	NTL-5	A2	NTL-1615-A2	NTS-A2	S4	NTL-1615-S4	NTS-S4
6	NTL-1615-6	NTS-6	NTL-6	A3	NTL-1615-A3	NTS-A3	T1	NTL-1615-T1	NTS-T1
7	NTL-1615-7	NTS-7	NTL-7	A4	NTL-1615-A4	NTS-A4	T2	NTL-1615-T2	NTS-T2
8	NTL-1615-8	NTS-8	NTL-8	F1	NTL-1615-F1	NTS-F1	T3	NTL-1615-T3	NTS-T3
9	NTL-1615-9	NTS-9	NTL-9	F2	NTL-1615-F2	NTS-F2	Blank	NTL-1615-Blank	NTS-Blank

PROGRESSIVE COOLING FAN LISTING

RECTANGULAR BORE FANS

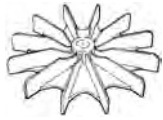

RB-A



RB-B

INSIDE DIA. (IN.)	OUTSIDE DIA. (IN.)	BLADE HEIGHT (IN.)	HUB RECESS (IN.)	# OF FINS	SUGGESTED FRAME SIZE	MAT.	MOUNT TYPE	PHOTO REF.	PART NUMBER
7/16 X 5/8	6-3/8	7/8	0	12	56	PL	RB	RB-A	SLS-7
7/16 X 5/8	7-3/4	1-1/2	5/16	12		PL	RB	RB-B	SDO-32
7/16 X 5/8	8-3/8	1	0	12	180T/S213T	PL	RB	RB-A	SLS-8
1/2 X 5/8	5-3/4	3/4	0	12	56	PL	RB	RB-C	SEM-386
1/2 X 5/8	6	1-1/8	1/16	9	56	PL	RB	RB-D	SCN-518
17/32 X 25/32	7-3/4	7/8	-3/4	12		PL	RB	RB-B	SDO-37

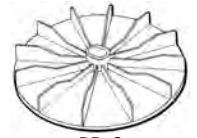

RB-C



RB-D

ROUND BORE FANS

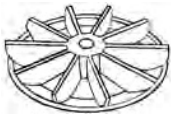

RD-A



RD-B

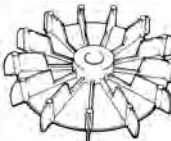

RD-C



RD-D



RD-E

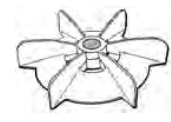

RD-F

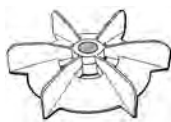

RD-G



RD-H

INSIDE DIA. (IN.)	OUTSIDE DIA. (IN.)	BLADE HEIGHT (IN.)	HUB RECESS (IN.)	# OF FINS	SUGGESTED FRAME SIZE	MAT.	MOUNT TYPE	PHOTO REF.	PART NUMBER
5/16	3-3/4	5/8	-	10	34R	PL	PO	RD-A	SBO-24
3/8	4-1/2	7/8	-	10	42R	PL	PO	RD-B	SBO-22
15/32	6-3/8	1	3/8	14		CA	PO	RD-C	SDO-39
1/2	5-1/2	1-1/32	-	5	48R	PL	PO	RD-D	SBO-23
1/2	5-3/4	13/16	1/4	12	56	SS	SS	RD-E	SDO-20
9/16	5-1/4	7/8	0	6	56	CA	CM	RD-F	SUS-10
9/16	5-1/2	1	0	6	140T	PL	PO	RD-G	SLN-1
19/32	5-1/8	13/16	7/16	15	56	CA	PO	RD-H	SGE-1055
19/32	5-1/8	7/8	1/4	12	56	CA	SS	RD-I	SGE-1118
5/8	5-1/4	3/4	0	8	48/56T	SA	LC	RD-J	SBA-81
5/8	5-3/4	13/16	1/4	12	56	SS	SS	RD-E	SDO-26
5/8	5-3/4	13/16	1/2	11	56	CA	SS	RD-K	SGE-1057
5/8	5-3/4	1	5/16	12	140T/180TS	CA	SS	RD-I	SAL-1
5/8	5-3/4	1	1/4	12	140T	CA	SS	RD-I	SGE-1119
5/8	5-3/4	1	1/4	12	56	CA	SS	RD-I	SGE-1121
5/8	5-7/8	1	7/16	12	56	CA	SS	RD-L	SWH-487
5/8	6	1	0	11	56	CA	SS	RD-M	SMR-110
5/8	6	1-1/8	1/8	9	56	PL	CM	RD-N	SCN-488
5/8	6-1/8	3/4	0	8	56/140T	SA	LC	RD-J	SBA-72
5/8	6-1/4	13/16	0	10	56	CA	SS	RD-O	SMR-85
5/8	6-1/4	13/16	0	10	140	CA	SS	RD-O	SMR-95
5/8	6-1/4	1	-1/16	6	140T	PL	CM	RD-P	SDC-1000
5/8	6-1/4	1	1/8	14	140T	PL	CM	RD-Q	SLA-10
5/8	6-3/8	15/16	0	13	56/140	CA	SS	RD-C	SMA-202
5/8	6-3/8	1	1/4	12	140T	CA	SS	RD-I	SMA-222
5/8	6-5/8	7/8	9/16	12	56	CA	SS	RD-R	SFK-27
5/8	6-5/8	7/8	9/16	12	56	CA	Pin	RD-R	SFK-68
5/8	6-7/8	1-1/8	1/2	8	66T	SA	SS	RD-S	SBA-73
5/8	7	7/8	0	12		SS	SS	RD-T	SDO-42
5/8	7-1/4	1-1/2	5/16	9	180T	PL	CM	RD-U	SMA-203
5/8	7-1/2	1-1/8	1/4	12	180T	CA	SS	RD-I	SMA-223
5/8	7-3/4	1	1/4	14	180T/210TS	CA	SS	RD-I	SAL-2
5/8	8	1-1/2	1/4	9	180T	CA	CM	RD-U	SCN-500
5/8	8-1/4	1-1/2	0	14	180	CA	CM	RD-W	SMR-96
5/8	8-3/4	1-1/2	3/16	12	210T	CA	SS	RD-I	SAL-3
5/8	9	1-1/2	3/8	12	210T	CA	SS	RD-I	SMA-227
5/8	9-1/8	1-1/2	1/4	9	210T	PL	CM	RD-U	SMA-204
41/64	4-7/8	13/16	0	9	56/140T	PL	PO	RD-X	SBA-117
41/64	5-7/8	3/4	0	10	56	PL	CM	RD-Y	SBA-95
41/64 W/Flat	6	3/4	0	10	56	PL	CM	RD-ZSBA-106	
17 MM	5-3/4	1-1/8	3/16	12	140T	PL	CM	RD-AA	SGE-1040
17 MM	6-1/8	3/4	3/16	14	140T	PL	CM	RD-Q	SLA-1
43/64	4-3/4	9/16	-3/16	13	48	PL	PO	RD-BB	SCN-512
43/64	4-3/4	13/16	-1/8	11	48	CA	PO	RD-DD	SAW-39
43/64	4-3/4	7/8	-1/16	20	48	PL	PO	RD-EE	SAW-54
43/64	5	9/16	0	13		CA	PO	RD-CC	SCN-520
43/64	5-3/8	9/16	0	13	56	PL	PO	RD-CC	SCN-489
43/64	5-1/2	9/16	0	13	56	CA	PO	RD-CC	SCN-487
43/64	5-1/2	3/4	1/8	11	56	CA	CM	RD-FF	SGE-1146
43/64	7	1-1/8	1/2	8	66	SA	SS	RD-S	SBA-92
11/16	5-1/2	7/8	0	12		PL	PO	RD-GG	SWH-549
11/16	5-5/8	11/16	0	12	140T	PL	PO	RD-HH	SUS-11
18 MM	6-1/2	1		10	140T	PL	CM	RD-II	SGE-1163
47/64	3	5/8	0	8		SS	PO	RD-JJ	SMR-116
47/64	4-1/8	3/4	0	10	48	SS	PO	RD-JJ	SMR-112
47/64	4-7/8	3/4	5/16	10	56	SS	PO	RD-JJ	SMR-113
47/64	4-7/8	3/4	0	10	56	SS	PO	RD-KK	SMR-118
47/64	4-7/8	3/4	0	10	56	SS	PO	RD-KK	SMR-118
3/4	4-1/8	3/4	0	10	56	SS	PO	RD-JJ	SMR-78
3/4	4-3/4	9/16	3/4	12	48	SS	PO	RD-LL	SFK-25
3/4	4-7/8	3/4	0	10	56	SS	PO	RD-JJ	SMR-79
3/4	5	11/16	3/8	10	56	SS	PO	RD-LL	SLS-33
3/4	5	3/4	3/8	10	56	SS	PO	RD-MM	SLF-8
3/4	7-1/2	1-1/8	1/4	12	180T	CA	SS	RD-I	SLA-3



RD-I



RD-J

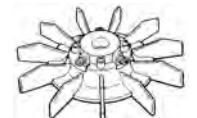

RD-K



RD-L

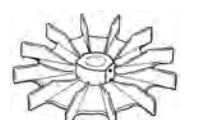

RD-M



RD-N



RD-O



RD-P

PROGRESSIVE COOLING FAN LISTING

ROUND BORE FANS

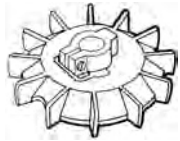

RD-Q

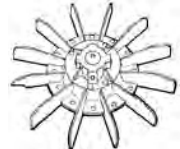

RD-R



RD-S

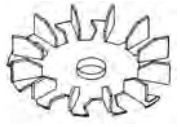

RD-T

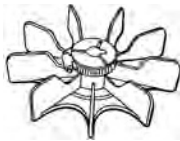

RD-U



RD-V

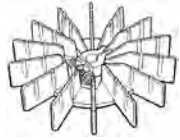

RD-W



RD-X



RD-Y

INSIDE DIA. (IN.)	OUTSIDE DIA. (IN.)	BLADE HEIGHT (IN.)	HUB RECESS (IN.)	# OF FINS	SUGGESTED FRAME SIZE	MAT.	MOUNT TYPE	PHOTO REF.	PART NUMBER
25/32	8-1/2	1-1/16	1/2	8	210T	SA	SS	RD-S	SBA-75
25/32	4-3/4	11/16	-1/16	20	48	PL	PO	RD-EE	SAW-48
20 MM	5-3/4	1	1/4	12	56	CA	SS	RD-I	SGE-1120
20 MM	6-1/8	1-1/8		6	180TS	PL	CM	RD-II	SGE-1164
51/64	5-1/2	7/8	0	13		CA	PO	RD-CC	SCN-521
13/16	5-3/8	15/16	11/16	14	140T	PL	CM	RD-Q	SLA-6
13/16	5-3/8	1-1/8	7/16	11	56	PL	PO	RD-NN	SAW-55
13/16	5-3/8	1-5/16	7/16	11	56	PL	PO	RD-NN	SAW-43
13/16	5-3/8	1-5/16	7/16	11	56	PL	PO	RD-OO	SAW-56
13/16	7-1/4	1-1/2	1/4	6	180T	PL	PO	RD-G	SLN-2
22 MM	6-1/4	1-1/8	3/16	8	140T	PL	PO	RD-PP	STA-1
7/8	4-3/8	5/8	1/4	10	56	SS	PO	RD-JJ	SDO-40
7/8	4-3/4	9/16	3/4	12	56	SS	PO	RD-LL	SFK-26
7/8	4-7/8	1	3/8	10	56	SS	PO	RD-KK	SMR-80
7/8	5-1/8	13/16	0	12	56	SS	PO	RD-KK	SDO-19
7/8	5-5/8	1	1/4	12	180U	CA	SS	RD-I	SUS-92
7/8	6-3/4	1-1/4	1/4	8	210TS	PL	CM	RD-QQ	SUS-24
7/8	7-1/4	1-1/2	1/2	16	180T	PL	CM	RD-RR	SLA-2
7/8	7-1/4	1-1/2	1/4	9	180T	PL	CM	RD-U	SMA-210
7/8	7-3/8	2	0	14	210T	PL	CM	RD-SS	SGE-1152
7/8	7-1/2	1-1/8	1/4	12	180T	CA	SS	RD-I	SMA-224
7/8	8	1-3/8	3/16	8	180T/210T	PL	CM	RD-QQ	SUS-12
7/8	9	1-1/2	3/8	12	210T	CA	SS	RD-I	SMA-230
7/8	9-3/4	1-7/16	0	12	210T	CA	SS	RD-C	SLS-19
7/8	10	1-1/2	0	15	250T	PL	CM	RD-TT	SMA-208
7/8	10-1/2	1-3/4	1/4	13	250T	PL	CM	RD-U	SMA-205
7/8	10-3/4	1-5/8	5/16	12	250T	CA	SS	RD-I	SMA-236
23 MM	4-3/4	1	3/16	6	140T 2P	PL	CM	RD-UU	SLFI-80
23 MM	6-1/4	1	3/16	10	140T 4P	PL	CM	RD-UU	SLFI-81
29/32	5-5/8	1/2	0	12	56	SS	PO	RD-LL	SBA-103
29/32	5-7/8	3/4	0	10	180T 2P	PL	CM	RD-Y	SBA-96
29/32	6-1/2	15/16	0	12	56	CA	SS	RD-C	SLS-32
29/32	7	1-1/8	1/2	8	180T	SA	SS	RD-S	SBA-71
29/32	7	1-1/8	0	10	180T	PL	CM	RD-Y	SBA-97
15/16	7-1/4	1-1/2	1/4	9	180T	PL	CM	RD-U	SMA-211
15/16	7-1/2	1-1/8	1/4	12	180T	CA	SS	RD-I	SMA-225
15/16	8	1-1/2	5/16	6	180T	PL	CM	RD-VV	SDC-1001
15/16	8-3/4	1-1/2	1/2	12	210T	CA	SS	RD-I	SMR-98
15/16	9	1-5/8	1/4	14	210	CA	CM	RD-W	SMR-97
25 MM	5-3/4	5/8	0	10	56	CA	SS	RD-WW	SBA-102
25 MM	4-1/8	3/4	0	10	48	SS	PO	RD-JJ	SMR-117
25 MM	4-7/8	3/4	7/16	10	56	SS	PO	RD-KK	SMR-114
25 MM	4-7/8	3/4	5/16	10	56	SS	PO	RD-JJ	SMR-119
25 MM	5-5/8	1	1/4	12	140T	CA	SS	RD-XX	SWH-526
25 MM	6	1	1/4	12	180TS	CA	SS	RD-XX	SWH-527
25 MM	6	1-7/16	0	14	180TS	PL	CM	RD-AA	SGE-1041
25 MM	7	1-1/4	5/8	12	180T	PL	CM	RD-UU	SGE-1042
25 MM	7	1-1/4	1/2	12	180T	CA	SS	RD-I	SGE-1123
25 MM	7-1/4	1-7/16	7/16	12	180T	CA	SS	RD-XX	SWH-529
25 MM	7-1/4	1-1/2	0	12	180T	CA	SS	RD-YY	SGE-1124
25 MM	7-3/8	1-1/2	0	14	180T	PL	CM	RD-AA	SGE-1043
25 MM	8-1/8	1-1/4	1/4	10	180T	PL	CM	RD-II	SGE-1165
25 MM	8-1/8	1-5/16	3/16	10	250TS	PL	CM	RD-UU	SLFI-86
25 MM	8-1/2	1-1/4	5/8	12	210T	PL	CM	RD-UU	SGE-1045
25 MM	8-1/2	1-1/4	5/8	12	210	CA	SS	RD-I	SGE-1126
25 MM	9-1/2	1-1/2	3/8	10	210T	PL	CM	RD-II	SGE-1166
25 MM	9-1/2	1-1/2	3/8	10	280 TS	PL	CM	RD-UU	SLFI-88
25 MM	5-1/2	7/8	-1/16	12	56	PL	PO	RD-GG	SWH-505
63/64	6-1/8	3/4	0	8	56	SA	SS	RD-ZZ	SBA-99
63/64	8-1/2	1-1/16	7/16	8	210T	SA	SS	RD-S	SBA-93
63/64	10-1/4	1-3/4	-5/8	8	254-256	CA	SS	RD-AAA	SBA-98
1	4-1/8	3/4	0	10	56	SS	PO	RD-KK	SMR-82
1	4-7/8	3/4	0	10	56	SS	PO	RD-JJ	SMR-81
1	4-7/8	3/4	0	10	56	SS	PO	RD-KK	SMR-83
1	5-1/4	7/8	-1/4	12	56	PL	PO	RD-BB	SDO-38
1	5-3/8	1-1/8	7/16	11	56	PL	PO	RD-NN	SAW-42
1	5-3/8	1-1/8	7/16	11	56	PL	PO	RD-NN	SAW-57
1	5-3/8	1-5/16	7/16	11	56	PL	PO	RD-OO	SAW-58
1	6-1/8	3/4	0	8	56	SA	SS	RD-ZZ	SBA-101
1	7-3/8	1-1/2	0	7	210TS	PL	PO	RD-BBB	SLN-5
1	8-3/4	1-7/16	3/16	7	210T	PL	PO	RD-CCC	SLN-3
1-1/16	11-1/2	1-3/4	0	15	280T	PL	CM	RD-DDD	SMA-209
28 MM	6-1/8	1-1/8	1/4	6	180T 2P	PL	CM	RD-UU	SLFI-82
28 MM	7-1/8	1-3/8	3/8	6	210T 2P	PL	CM	RD-UU	SLFI-84
28 MM	8	1-3/8	3/8	8	180T	PL	PO	RD-PP	STA-2
28 MM	8-1/8	1-1/4	3/16	10	180T 4P	PL	CM	RD-UU	SLFI-83
28 MM	9-1/2	1-3/4	3/8	10	210T 4P	PL	CM	RD-UU	SLFI-145
28 MM	11-1/8	2	3/8	10	250T 4P	PL	CM	RD-UU	SLFI-87
1-1/8	5-3/8	1-5/16	7/16	11	56	PL	PO	RD-NN	SAW-44
1-1/8	5-3/8	1-5/16	7/16	11	56	PL	PO	RD-OO	SAW-59
1-1/8	6-3/8	7/8	-1/4	12		PL	PO	RD-BB	SDO-36
1-1/8	6-3/4	1-1/4	3/16	8	180TS	PL	CM	RD-QQ	SUS-13
1-1/8	7	1-1/8	0	10	180T	PL	CM	RD-Y	SBA-118
1-1/8	7-1/4	1-1/2	1/4	9	180T	PL	CM	RD-U	SMA-212
1-1/8	9	1-1/2	3/16	9	210T	CA	CM	RD-V	SCN-501
1-1/8	9	1-1/2	3/8	9	210T	CA	SS	RD-EEE	SCN-503



RD-Z



RD-AA



RD-BB

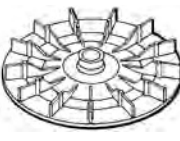

RD-CC

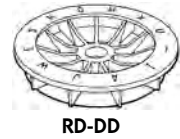

RD-DD



RD-EE



RD-FF



RD-GG



RD-HH

PROGRESSIVE COOLING FAN LISTING

ROUND BORE FANS



RD-II



RD-JJ



RD-KK



RD-LL



RD-MM



RD-NN



RD-OO



RD-PP



RD-QQ

INSIDE DIA. (IN.)	OUTSIDE DIA. (IN.)	BLADE HEIGHT (IN.)	HUB RECESS (IN.)	# OF FINS	SUGGESTED FRAME SIZE	MAT.	MOUNT TYPE	PHOTO REF.	PART NUMBER
1-1/8	9	1-1/2	3/8	12	250US/250TS	CA	SS	RD-FFF	SGE-1047
1-1/8	9	1-1/2	1/4	9	210T	PL	CM	RD-U	SMA-213
1-1/8	9	1-1/2	3/8	12	210T	CA	SS	RD-I	SMA-228
1-1/8	9-1/4	1-5/8	7/16	8	250T	CA	SS	RD-FFF	SUS-28
1-1/8	9-3/8	1-1/8	3/8	8	210T	PL	CM	RD-GGG	SUS-37
1-1/8	9-3/4	1-1/2	3/8	12	250U/250T	CA	SS	RD-HHH	SGE-1048
1-1/8	10-1/2	1-3/8	7/16	12	250T	CA	SS	RD-I	SMA-233
1-1/8	10-5/8	1-3/4	3/8	12	250T	CA	SS	RD-EEE	SCN-504
1-1/8	11-1/2	1-1/2	1/2	12	280U/280T	CA	SS	RD-HHH	SGE-1050
1-1/8	11-3/4	2	3/8	13	280T	PL	CM	RD-U	SMA-206
1-1/8	11-3/4	2	5/8	12	280T	CA	SS	RD-YY	SMA-239
1-5/32	7-1/2	1-1/8	1/4	12	180T	CA	SS	RD-I	SMA-226
1-5/32	9	1-1/2	3/8	12	210T	CA	SS	RD-I	SMA-229
1-5/32	8-3/4	1-3/4	1/2	11	210T	CA	SS	RD-XX	SAL-6
30 MM	4-7/8	3/4	7/16	10	56	SS	PO	RD-KK	SMR-120
1-2/11	6-3/4	1-7/16	7/16"	12	210TS	CA	SS	RD-XX	SWH-528
1 2/11	9	1-1/2	3/8"	12	210T	CA	SS	RD-I	SWH-533
1-3/16	5-1/4	3/4	13/16"	11	140	CA	PO	RD-III	SMR-91
1-3/16	5-5/8	1/2	5/8"	12	56	SS	PO	RD-LL	SBA-100
1-3/16	5-5/8	13/16	0	10	56	SS	PO	RD-KK	SBA-107
1-3/16	5-3/4	5/8	0	10	56	CA	SS	RD-WW	SBA-104
1-3/16	7-1/4	1-1/2	0	12	180T	CA	SS	RD-YY	SGE-1125
1-3/16	7-3/8	1-1/2	0	14	180T/210TS	PL	CM	Fan-U	SGE-1044
1-3/16	8-1/2	1-1/16	3/8	8	213-215	SA	SS	RD-S	SBA-112
1-3/16	8-1/2	1-1/16	0	10	210T	PL	CM	RD-Y	SBA-74
1-3/16	8-3/4	1-1/2	0	14	210T	PL	CM	RD-AA	SGE-1046
1-3/16	8-3/4	1-1/2	3/16	12	210T	CA	SS	RD-JJJ	SGE-1127
1-3/16	9	1-5/16	5/16	14	210T/250TS	CA	PO	RD-BBB	SLN-6
1-3/16	9-1/2	2	1/2	6	210T	PL	CM	RD-VV	SDC-1002
1-3/16	10-3/8	1-1/4	1/4	8	250T	PL	PO	RD-CCC	SLN-4
1-1/4	6-1/8	13/16	-1/4	12		SS	PO	RD-T	SDO-43
1-1/4	6-3/8	7/8	-1/2	12		PL	PO	RD-BB	SDO-24
1-1/4	6-7/8	1	1-3/16	17	180T	PL	CM	RD-Q	SLA-7
1-1/4	8-1/2	1-1/4	5/8	12	210T	CA	SS	RD-I	SUS-26
1-1/4	9	1-5/8	1/4	14	250T	PL	CM	RD-GGG	SUS-19
1-1/4	9-3/8	1-1/2	3/8	8	250T	CA	SS	RD-I	SMR-99
1-1/4	10-1/2	1-3/8	7/16	12	250T	CA	SS	RD-I	SMA-234
1-1/4	11	2-1/8	0	14	280T	PL	CM	RD-GGG	SUS-17
1-1/4	13-1/2	2-1/4	7/16	13	320T	PL	CM	RD-U	SMA-207
1-1/4	13-1/2	2-1/4	3/4	12	320T	CA	SS	RD-YY	SMA-241
1-5/16	6-3/4	7/8	9/16	12	180T	SS	PO	RD-LL	SLS-34
1-11/32	7-1/4	13/16	1	11	180	CA	PO	RD-III	SMR-89
1-3/8	8-1/8	2-1/8	0	14		PL	CM	RD-GGG	SUS-38
1-3/8	8-1/4	1-1/2	-1/8	11		PL	CM	RD-U	SMR-109
1-3/8	8-1/2	1-1/8	0	10	210T	PL	CM	RD-Y	SBA-119
1-3/8	8-3/4	1-7/16	1	16	210T	PL	CM	RD-RR	SLA-4
1-3/8	8-3/4	1-1/2	3/16	12	280T	CA	SS	RD-I	SAL-5
1-3/8	9	1-1/2	3/8	12	210T	CA	SS	RD-I	SMA-231
1-3/8	9-3/4	1-1/2	3/8	12	250U/250T	CA	SS	RD-HHH	SGE-1049
1-3/8	10-1/8	1-1/2	1/2	12	250U/250T	CA	SS	RD-BBB	SGE-1084
1-3/8	10-1/4	1-7/8	1	16	250T	PL	CM	RD-RR	SLA-15
1-3/8	10-3/8	1-3/4	-9/16	8	250T	CA	SS	RD-AAA	SBA-77
1-3/8	10-1/2	1-3/8	7/16	12	250T	CA	SS	RD-I	SMA-237
1-3/8	11	1-7/8	-1/4	11		PL	CM	RD-U	SMR-111
1-3/8	11-1/8	2-1/8	0	14		PL	CM	RD-GGG	SUS-39
1-3/8	11-1/2	1-1/2	1/2	12	280U/280T	CA	SS	RD-YY	SGE-1051
1-3/8	11-3/4	2-5/16	1-1/4	16	280T	PL	CM	RD-RR	SLA-16
1-3/8	12-5/8	1-5/8	5/8	12	280T	CA	SS	RD-KKK	SAL-7
1-3/8"	14	2-1/8	1/2	12	320T	CA	SS	RD-HHH	SAL-8
35 MM	8-1/2	1-1/4	5/8	12	250TS	CA	SS	RD-I	SWH-530
35 MM	10	1-1/2	7/16	12	250T	CA	SS	RD-I	SWH-535
1-13/32	7	1	-1/4	11	180	CA	SS	RD-JJJ	SCN-492
1-13/32	10-1/2	1-3/8	7/16	12	250T/320TS	CA	SS	RD-I	SAL-4
36 MM	11-3/4	2	5/8	12	280T	CA	SS	RD-I	SMR-100
36 MM	9-1/2	1-3/8	7/16	12	210T	CA	SS	RD-YY	STA-5
36 MM	9-1/2	1-3/4	3/8	8	210T	PL	SS	RD-PP	STA-3
1-7/16	6-1/2	7/16	0	12	182-184	SS	PO	RD-LL	SBA-105
1-7/16	6-1/2	1	0	10	182-184	SS	PO	RD-KK	SBA-111
1-7/16	11-1/2	2-5/8	13/16	8	250T	PL	CM	RD-MMM	SDC-1003
1-1/2	6-3/8	7/8	-1/2	12		PL	PO	RD-BB	SDO-44
1-1/2	10-1/4	1-3/4	0	8	250T	PL	CM	RD-LLL	SBA-82
1-9/16	11	2-1/8	5/8	11	280T	CA	SS	RD-XX	SWH-494
40 MM	5-3/4	1-3/4	0	6	250	CA	SS	RD-NNN	SGE-1098
1-39/64	6-3/4	1-1/16	-5/8	15	180T	CA	PO	RD-OOO	SGE-1090
1-39/64	7-1/4	13/16	1	11	180	CA	PO	RD-III	SMR-88
1-39/64	8	1-1/8	15/16	16	180T	CA	PO	RD-III	SMR-115
1-5/8	7-1/2	1-3/8	1-1/4	12	210T	CA	SS	RD-PPP	SLA-8
1-5/8	8	1-1/8	1-1/8	10	210T	SS	PO	RD-LL	SBA-76
1-5/8	9	1-1/2	3/8	12	210T	CA	SS	RD-I	SMA-232
1-5/8	10	1-1/2	7/16	12		PL	CM	RD-UU	SGE-1080
1-5/8	10-1/2	1-3/8	7/16	12	250T	CA	SS	RD-I	SMA-238
1-5/8	10-1/2	1-7/8	7/16	10	280T	PL	CM	RD-QQ	SUS-18
1-5/8	10-3/4	1-1/2	3/8	12	280U/280T	CA	SS	RD-BBB	SGE-1085
1-5/8	11-1/8	1-1/2	3/8	12	280T	CA	SS	RD-BBB	SGE-1086
1-5/8	11-1/2	1-1/2	1/2	12	320US/320TS	CA	SS	RD-HHH	SGE-1081
1-5/8	12-1/4	1-3/4	3/8	12	280T/320T	CA	SS	RD-YY	SCN-505

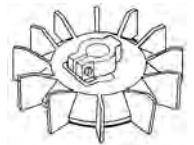

RD-RR



RD-SS



RD-TT



RD-UU



RD-VV

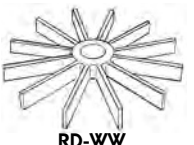

RD-WW

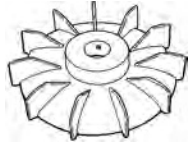

RD-XX



RD-YY

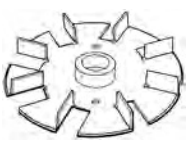

RD-ZZ

PROGRESSIVE COOLING FAN LISTING

ROUND BORE FANS



RD-AAA



RD-BBB



RD-CCC



RD-DDD



RD-EEE



RD-FFF



RD-GGG



RD-HHH



RD-III



RD-JJJ



RD-KKK



RD-LLL

INSIDE DIA. (IN.)	OUTSIDE DIA. (IN.)	BLADE HEIGHT (IN.)	HUB RECESS (IN.)	# OF FINS	SUGGESTED FRAME SIZE	MAT.	MOUNT TYPE	PHOTO REF.	PART NUMBER
1-5/8	13	1-5/8	1/2	12	320T	CA	SS	RD-BBB	SGE-1087
1-5/8	13	1-3/4	3/8	12	320U/320T	CA	SS	RD-HHH	SGE-1082
42 MM	9-3/8	1-1/2	3/8	8	250T	CA	SS	RD-FFF	SLS-20
42 MM	11	2-1/8	5/8	12	280T	CA	SS	RD-XX	SLS-21
42 MM	14-1/8	2-1/4	5/8	12	320T	CA	SS	RD-FFF	SMR-101
1-43/64	7-3/4	1-7/16	-3/4	16		PL	PO	RD-BB	SDO-41
1-11/16	7-5/8	1-1/4	0	11	210T	CA	SS	RD-QQQ	SCN-493
1-11/16	10-1/4	1-3/4	1/8	8	254-256	PL	CM	RD-LLL	SBA-110
1-11/16	10-1/4	1-7/8	1	16	250T	PL	CM	RD-RR	SLA-17
1-45/64	11-3/4	2	-3/8	10	280T	PL	CM	RD-RRR	SBA-83
1-3/4	11-5/8	2-1/2	1-7/16	10	280T	CA	SS	RD-HHH	SLA-5
1-3/4	11-3/4	2	5/8	12	280T	CA	SS	RD-YY	SMA-240
1-3/4	11-3/4	2-5/16	1-1/4	16	280T	PL	CM	RD-RR	SLA-18
45 MM	6-1/2	2-3/16	-3/16	6	280	CA	SS	RD-NNN	SGE-1099
1-27/32	8-1/2	1-1/4	5/8	12	280TS	CA	SS	RD-I	SWH-531
1-27/32	11	2-1/8	5/8	12	280T	CA	SS	RD-YY	SWH-536
45 MM	11-1/4	2	5/8	10	320 TS	CI	PO	RD-SSS	SLFI-90
45 MM	12-3/4	2-1/4	5/8	10	280T	CI	PO	RD-SSS	SLFI-89
1-7/8	8	1-1/8	1	16	250T	CA	PO	RD-III	SMR-106
1-7/8	10-1/2	1-3/8	7/16	12	250T	CA	SS	RD-I	SMA-235
1-7/8	12-1/2	2-7/16	1	8	280T	PL	CM	RD-MMM	SDC-1004
1-7/8	13-1/4	2	1/2	12	324T	PL	CM	RD-QQ	SUS-29
1-7/8	14-7/8	2-1/2	15/16	12	360T	CA	SS	RD-YY	SMA-243
1-7/8	15-3/8	2-7/8	5/8	13	360T	PL	SS	RD-U	SMA-216
48 MM	12-5/8	2-1/2	1-1/4	12	320T	CA	SS	RD-XX	SLS-22
1-15/16	12-5/8	2-1/2	1	12	320T	CA	SS	RD-YY	SLA-11
50 MM	9	1-1/2	3/8	12	280TS	CA	SS	RD-YY	STA-4
50 MM	11	2-1/8	5/8	12	280TS	CA	SS	RD-YY	STA-6
50 MM	13	2-7/16	5/16	12	280T	CA	CM	RD-TTT	STA-9
50 MM	14-1/4	2-3/4	5/8	10	320T	CI	PO	RD-SSS	SLFI-91
1-31/32	14	2-1/8	1/2	12	360T	CA	SS	RD-YY	SCN-506
2	8	1-3/16	0	10	213-215	SS	PO	RD-LL	SBA-109
2	9-3/4	1-3/4	1-3/8	12	250T	CA	SS	RD-PPP	SLA-9
2	10	2	3/8	10	280T	PL	CM	RD-RRR	SBA-116
2	13-1/2	2-1/4	3/4	12	320T	CA	SS	RD-YY	SMA-242
2-1/16	8	13/16	1	16	250	CA	PO	RD-III	SMR-92
2-1/8	13	2-5/8	1	8	320T	CA	CM	RD-UUU	SDC-1005
2-1/8	13-3/8	2-3/4	7/16	15	360T	PL	CM	RD-VVV	SBA-90
2-1/8	13-7/8	2-1/4	0	12	360U/360T	PL	CM	RD-QQ	SUS-30
2-1/8	14-1/4	2-1/2	1-1/8	12	360T	CA	Bolt	RD-BBB	SGE-1088
2-1/8	16-1/4	3	1-5/16	12	440T	CA	SS	RD-HHH	SAL-10
2-1/8	17-7/8	2-5/8	1-1/4	15	440T	CA	SS	RD-HHH	SAL-12
55 MM	16-1/4	2-3/4	0	13	440U/400T	PL	CM	RD-WWW	SGE-1094
2-1/6	9	1-1/2	3/8	12	320TS	CA	SS	RD-I	SWH-532
55 MM	9-1/2	2	0	9	360TS	CA	SS	RD-XXX	SGE-1096
55 MM	11	2-1/8	5/8	12	320TS/360T	CA	SS	RD-YY	STA-7
55 MM	11-1/2	2-5/8	0	9	440US/400TS	PL	SS	RD-WWW	SGE-1092
55 MM	12-5/8	2-1/2	1-1/4	12	360T	CA	SS	RD-XX	SLS-23
2-1/6	12-5/8	2-1/2	1	12	320T	CA	SS	RD-YY	SWH-537
2-1/6	14-3/8	2-1/2	15/16	12	360T	CA	SS	RD-YY	SWH-538
55 MM	14-5/8	2-3/4	0	12	360U/360T	PL	SS	RD-WWW	SGE-1093
55 MM	15-3/4	2-3/4	5/8	10	360T	CI	PO	RD-SSS	SLFI-93
2-3/16	9-1/2	1-5/8	-1	8	254-256	CA	SS	RD-YY	SBA-108
2-3/16	15-1/2	2-1/2	0	12	360T	CA	SS	RD-FFF	SMR-102
2-1/4	14-3/4	2-1/2	1	12	360T	CA	SS	RD-HHH	SAL-9
2-1/4	20-3/4	3-1/2	0	16	6323/6324	CA	SS	RD-YY	SGE-1102
57-MM	7-1/4	2-1/2	3/4	6	320	CA	SS	RD-NNN	SGE-1100
57 MM	8-3/8	2-1/2	3/4	6	320	CA	SS	RD-NNN	SGE-1101
2-5/16	7-5/8	1-1/4	0	11	210T	CA	SS	RD-QQQ	SCN-495
2-5/16	16	2-5/8	1-1/4	12	400T	CA	SS	RD-HHH	SAL-11
2-21/58	9	1-1/2	3/8	12	400TS	CA	SS	RD-I	SWH-534
60 MM	12-5/8	2-1/2	1	12	400TS	CA	SS	RD-YY	STA-8
60 MM	13-3/8	2-1/4		12	320T	CA	SS	RD-TTT	STA-10
2 21/58	14	2-7/8	7/8	12	400T	CA	SS	RD-XX	SWH-506
60 MM	14-7/8	2-1/2	15/16	12	400T	CA	SS	RD-YY	SLS-24
60 MM	15	2-5/8	7/16	12	360T	CA	CM	RD-TTT	STA-11
60 MM	16-3/4	3	5/8	10	405T	CI	PO	RD-SSS	SLFI-149
2 21/58	17	3-1/4	7/8	12	400T	CA	SS	RD-XX	SWH-507
2-3/8	14	2-5/8	1	9	360T	CA	CM	RD-UUU	SDC-1006
2-3/8	16-1/8	2-5/8	3/4	12	400T	PL	CM	RD-GGG	SUS-31
2-3/8	19	3-1/4	7/8	12	440T	CA	SS	RD-XX	SWH-496
2-7/16	14-7/8	2-1/2	15/16	12	360T	CA	SS	RD-YY	SLA-12
2-7/16	17	2-1/2	1-1/4	12	400T/440T	CA	SS	RD-YY	SMA-244
2-7/16	20-3/4	3-1/2	0	16	440T	CA	SS	RD-YY	SMA-245
2-1/2	7-5/8	1-1/4	0	11	210T	CA	SS	RD-QQQ	SCN-496
2-1/2	12-1/2	2-1/2	0	10	440US/440TS	CA	SS	RD-JJJ	SGE-1130
2-1/2	17	2-1/2	1-1/4	12	440T	CA	SS	RD-XX	SWH-508
2-1/2	18	2-3/4	0	15	440U/440T	PL	CM	RD-WWW	SGE-1095
2-1/2	19	3-1/4	7/8	12	440T	CA	SS	RD-XX	SWH-509
65 MM	15-1/4	3	5/16	12	400T	CA	SS	RD-TTT	STA-12
2-5/8	16-1/4	3	1-5/8	13	400T	CA	SS	RD-HHH	SLA-13
68 MM	15-1/2	3	3/4	11	444T	CI	PO	RD-SSS	SLFI-150
3	17-1/2	3-1/4	0	12	440T	CA	SS	RD-YY	SBA-91
3	17-1/2	3-1/2	1-1/4	11	440T	CA	CM	RD-ZZZ	SLA-14



RD-MMM



RD-NNN



RD-OOO



RD-PPP



RD-QQQ



RD-RRR



RD-SSS



RD-TTT



RD-UUU



RD-VVV



RD-WWW



RD-XXX



RD-YYY



RD-ZZZ

BLANK BORE FANS

A FAN O.D. (IN.)	B BLADE HEIGHT (IN.)	# OF FINS	MAX. ALLOWED BORE (IN.)	C HUB DIA. (IN.)	D HUB THICK. (IN.)	E HUB RECESS (IN.)	PHOTO REF.	PART NUMBER
3-1/8	7/8	12	3/4	1-1/4	1/2	3/8	BB-1	SWSF-2
4-1/2	7/8	12	1-1/4	1-3/4	5/8	1/4	BB-1	SWSF-6
5	1	12	1	1-1/2	5/8	1/4	BB-1	SBBF-5
5-1/4	7/8	15	1-5/8	2-1/8	5/8	1/4	BB-1	SWSF-10
5-1/2	5/8	12	1-3/8	1-7/8	3/4	0	BB-5	SWSF-3-54
5-1/2	1	12	1-5/8	2-1/8	3/4	1/4	BB-7	SWSF-12
5-5/8	15/16	12	1-5/16	1-3/4	7/8	0	BB-1	SWSF-16
5-5/8	1	12	1-1/2	2	5/8	1/4	BB-1	SWSF-1-55
5-3/4	1-7/8	6	1-3/4	2-1/4	1-1/8	7/8	BB-3	SWSF-20
5-7/8	1-1/4	10	1-1/2	2	1	1/4	BB-2	SWSF-24
6	3/4	14	1-1/4	1-3/4	5/8	1/4	BB-1	SWSF-28
6	1	12	1-1/2	2	5/8	1/4	BB-1	SWSF-1-60
6	1	12	1-1/4	2	5/8	1/4	BB-1	SBBF-6
6-3/8	1	12	1-1/2	2	5/8	1/4	BB-1	SWSF-36
6-1/2	2-1/4	6	2	2-1/2	1-1/2	7/8	BB-3	SWSF-40
6-3/4	1	12	1-1/2	2	11/16	1/4	BB-1	SWSF-1-66
6-7/8	1-3/16	12	2	2-1/2	3/4	1/2	BB-1	SWSF-46
6-7/8	1-1/4	12	2	2-1/2	3/4	1/2	BB-1	SWSF-1-67
7	1-1/8	12	2	2-1/2	1	1	BB-7	SWSF-42
7	1-3/16	12	1-1/2	2	5/8	1/4	BB-1	SWSF-1-70
7	1-1/4	12	1-3/8	2-1/8	5/8	1/2	BB-1	SBBF-7
7	1-3/8	12	2	2-1/2	3/4	7/8	BB-7	SWSF-48
7-1/8	1-1/4	14	2-1/8	2-5/8	15/16	0	BB-1	SWSF-52
7-1/4	1-7/16	12	2	2-1/2	1-1/8	7/16	BB-1	SWSF-1-72
7-1/4	1-1/2	11	2	2-1/2	1-1/8	1/2	BB-2	SWSF-56
7-1/4	1-1/2	12	1-1/2	2	1	0	BB-6	SWSF-3-72
7-1/4	2-1/2	6	2-1/2	3	1-3/8	3/4	BB-3	SWSF-54
7-1/2	1-1/8	12	1-1/2	2	11/16	1/4	BB-1	SWSF-1-74
7-5/8	1-5/8	12	1-3/4	2-1/4	7/8	3/8	BB-1	SWSF-64
7-3/4	1	14	2-1/4	2-3/4	3/4	1/4	BB-1	SWSF-68
7-7/8	1-7/8	19	2	2-1/4	1	1-3/4	BB-7	SWSF-74
8	1-1/4	8	2	2-1/2	1	3/8	BB-1	SWSF-1-80
8	1-1/2	12	1-5/8	2-1/8	13/16	0	BB-5	SWSF-3-80
8	1-1/2	12	1-1/2	2-1/4	3/4	1/2	BB-1	SBBF-8
8-1/4	1	12	1-5/8	2-1/8	1	0	BB-5	SWSF-3-82
8-1/4	2-1/2	6	2-1/2	3	1-3/8	3/4	BB-3	SWSF-80
8-3/8	1-3/16	12	2-1/4	2-3/4	3/4	5/8	BB-1	SWSF-82
8-3/8	1-1/2	12	1-5/8	2-1/8	13/16	0	BB-5	SWSF-3-83
8-1/2	1-1/4	12	1-5/8	2-1/8	15/16	5/8	BB-1	SWSF-1-84
8-5/8	1-1/2	12	1-5/8	2-1/8	13/16	0	BB-5	SWSF-3-85
8-3/4	1-1/2	12	1-5/8	2-1/8	13/16	0	BB-5	SWSF-3-86
8-3/4	1-1/2	12	2	2-1/2	1-3/8	1/4	BB-1	SWSF-87
8-7/8	1-5/8	12	2-1/2	3	7/8	1-3/8	BB-7	SWSF-89
8-7/8	1-3/4	11	2	2-1/2	1-1/8	5/8	BB-2	SWSF-92
9	3/4	8	1-3/4	2-1/4	1-1/8	1/4	BB-4	SWSF-95
9	1-1/2	9	2-1/4	2-3/4	1-1/8	3/8	BB-1	SWSF-96
9	1-1/2	12	1-3/4	2-3/4	5/8	1/2	BB-1	SBBF-9
9-3/8	1-1/2	8	2	2-1/2	1-1/4	3/8	BB-1	SWSF-1-93
9-1/2	1-3/8	12	2-3/4	3-1/4	1-1/8	7/16	BB-1	SWSF-1-94
9-1/2	2	9	2-5/8	3-1/8	1-5/16	1-1/8	BB-6	SWSF-2-94
9-1/2	2	12	2-5/8	3-1/8	1-5/16	0	BB-5	SWSF-3-94
9-1/2	2	9	4-1/2	5	1-1/2	3/4	BB-1	SWSF-104
9-1/2	2	9	4-1/2	5	1-1/2	0	BB-4	SWSF-106
9-3/4	1-3/8	12	3	3-1/2	1-3/8	5/16	BB-1	SWSF-112
9-3/4	1-1/2	12	4-1/4	4-3/4	1-5/8	-3/8	BB-3	SWSF-110
9-3/4	1-3/4	12	2-7/8	3-3/8	1	1-3/8	BB-7	SWSF-102
10	1-1/2	12	2	3	3/4	1/2	BB-1	SBBF-10
10	1-1/2	12	3	3-1/2	1-3/8	7/16	BB-1	SWSF-1-100
10-1/8	1-1/2	12	1-3/4	2-1/4	1-3/8	1/2	BB-3	SWSF-116
10-1/8	2	12	3-1/2	4	1-1/4	3/4	BB-2	SWSF-124
10-1/2	1-3/8	12	2-3/4	3-1/4	1-1/8	7/16	BB-1	SWSF-1-104
10-5/8	1-3/4	12	3	3-1/2	1-1/2	3/8	BB-1	SWSF-126
10-3/4	1-1/2	12	2-7/8	3-3/8	1-1/2	3/8	BB-3	SWSF-5-106
10-3/4	1-1/2	12	1-7/8	3-3/8	1-3/8	3/8	BB-3	SWSF-132
10-3/4	2	9	4	4-1/2	1-1/2	1-1/4	BB-3	SWSF-134
10-7/8	1-7/8	12	3-1/2	4-1/4	1-3/8	2-1/4	BB-7	SWSF-136
11	1-1/2	12	2	3-3/8	3/4	1/2	BB-1	SBBF-11
11	1-3/4	12	3-1/2	4	1-3/8	0	BB-5	SWSF-3-110
11	2	12	3-3/4	4-1/4	1	1-3/4	BB-7	SWSF-139
11	2-1/8	12	3-1/2	4	1-3/8	5/8	BB-1	SWSF-1-110
11	2-1/8	11	3-1/2	4	1-3/8	5/8	BB-2	SWSF-140
11-1/8	1-1/2	12	2-7/8	3-3/8	1-1/2	3/8	BB-3	SWSF-5-111
11-1/4	1-1/2	12	1-7/8	2-3/8	1-1/2	3/8	BB-3	SWSF-5-112

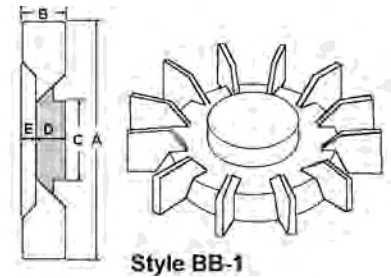

Style BB-1

Series BB-1 fans are used most often on horizontal TEFC induction motors. The hub recesses are usually small.

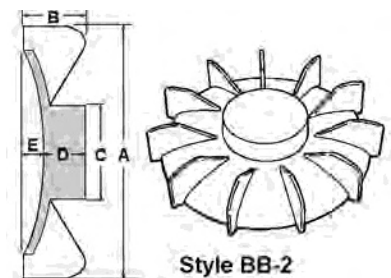

Style BB-2

Series BB-2 fans were made to fit Westinghouse motors, but are attractive sturdy fans for use on other motors, also.

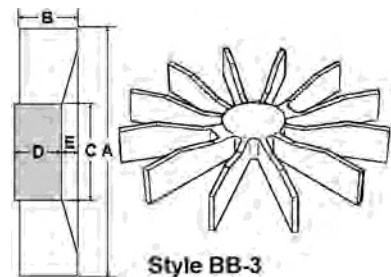

Style BB-3

Series BB-3 fans were made for use on textile type motors, but the absence of a back plate makes it ideal for replacing external fan blades.

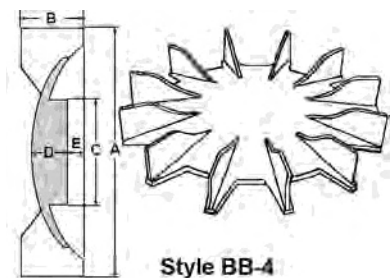

Style BB-4

First made to resemble General Electric plastic fans with a back-clamping split hub. Other manufacturers have machined the hub on the back to function as a bearing cover, or use a set screw near the back to mount the fan on a short shaft.

BLANK BORE FANS

A FAN O.D. (IN.)	B BLADE HEIGHT (IN.)	# OF FINS	MAX. ALLOWED BORE (IN.)	C HUB DIA. (IN.)	D HUB THICK. (IN.)	E HUB RECESS (IN.)	PHOTO REF.	PART NUMBER
11-3/8	1-5/8	12	3-1/2	4	1-1/2	3/8	BB-3	SWSF-142
11-3/8	1-3/4	12	2-5/8	3-1/8	1	1/2	BB-1	SWSF-1-113
11-1/2	1-1/2	12	3-1/2	4	1-3/8	7/16	BB-1	SWSF-146
11-1/2	2-5/8	9	4-1/2	5	1-3/4	1-1/2	BB-1	SWSF-150
11-1/2	2-5/8	9	4-1/2	5	1-1/2	0	BB-4	SWSF-148
11-5/8	2-1/2	10	3-1/4	3-3/4	1-5/16	1-3/8	BB-6	SWSF-2-115
11-5/8	2-1/2	12	3-1/4	3-3/4	1-5/16	0	BB-5	SWSF-3-115
11-3/4	1-1/2	12	3-1/2	4	1-1/2	1/2	BB-1	SWSF-152
11-3/4	1-3/4	12	3-1/4	3-3/4	1-1/4	1/2	BB-1	SWSF-1-116
11-3/4	2	12	3-1/2	4	1-3/8	5/8	BB-1	SWSF-162
11-3/4	2-1/8	8	3-3/8	3-7/8	1-1/4	7/8	BB-1	SWSF-166
12	2	12	2	3-3/8	1	3/4	BB-1	SBBF-1
12	2-1/2	12	3-1/2	4	1-3/8	1-3/8	BB-7	SWSF-167
12-1/2	1-7/8	12	3-1/2	4	1-1/4	9/16	BB-1	SWSF-1-124
12-1/2	2-5/8	12	4	3-7/8	1-1/4	2-7/8	BB-7	SWSF-173
12-1/2	2-1/2	10	3-3/4	4-1/4	1-5/8	0	BB-5	SWSF-3-124
12-1/2	2-1/2	12	4-1/2	5	1-1/2	1	BB-1	SWSF-178
12-1/2	2-1/2	12	4-1/2	5	1-1/2	0	BB-4	SWSF-180
12-5/8	2-1/2	12	4	4-1/2	1-3/8	1	BB-1	SWSF-1-125
12-5/8	2-1/2	11	4	4-1/2	1-1/2	7/8	BB-2	SWSF-182
12-7/8	1-1/2	14	2-7/8	3-3/8	1-1/8	5/8	BB-3	SWSF-5-127
13	1-5/8	12	3-1/2	4	1-1/4	1/2	BB-3	SWSF-184
13	1-3/4	12	4-1/2	5	1-3/8	3/8	BB-1	SWSF-186
13	2	12	3-1/2	4	1-3/8	1/2	BB-1	SWSF-1-130
13-1/4	2	12	3-1/2	4	1-3/8	3/4	BB-1	SWSF-1-132
13-1/2	2-1/4	12	4-1/2	5	1-3/4	3/4	BB-1	SWSF-190
14	2	12	2-1/4	3-1/2	1	3/4	BB-1	SBBF-14
14	2-1/8	12	3-1/2	4	1-9/16	9/16	BB-1	SWSF-1-140
14	2-7/8	12	4-1/4	5	1-7/8	7/8	BB-2	SWSF-194
14-1/8	2-1/4	10	2-7/8	3-5/8	1-5/8	5/8	BB-1	SWSF-196
14-1/4	2-1/2	12	3-3/4	4-1/2	1-5/8	1-1/8	BB-3	SWSF-198
14-5/8	2-1/2	12	3-1/2	4-1/4	1-5/8	1-7/16	BB-6	SWSF-2-145
14-5/8	2-1/2	12	3-1/2	4-1/4	1-5/8	0	BB-5	SWSF-3-145
14-5/8	2-3/4	12	4-1/4	5	1-5/8	0	BB-4	SWSF-202
14-5/8	2-3/4	12	4-1/4	5	1-1/2	1-3/8	BB-1	SWSF-200
14-7/8	2-1/2	12	3-7/8	4-5/8	1-5/8	15/16	BB-1	SWSF-1-147
15-3/4	3	13	4-1/4	5	1-3/4	1-5/8	BB-1	SWSF-208
16	2	12	2-3/4	4-1/2	1	3/4	BB-1	SBBF-16
16	2-1/2	12	4-1/4	5	1-3/4	1-3/16	BB-1	SWSF-1-160
16-1/8	3	8	2-3/4	3-1/2	2	1-1/4	BB-1	SWSF-206
16-1/4	3	12	4	4-3/4	1-3/4	1-5/8	BB-6	SWSF-2-162
16-1/4	3	12	4	4-3/4	1-3/4	0	BB-5	SWSF-3-162
16-1/4	3	12	4-1/4	5	1-1/2	3/8	BB-4	SWSF-4-162
17	2-1/2	12	4-1/2	5	1-3/4	1-1/4	BB-1	SWSF-1-170
17	3-1/4	12	4-1/4	5	2-1/2	7/8	BB-2	SWSF-212
17-1/2	3-1/4	12	4-1/4	5	2-1/4	0	BB-5	SWSF-3-174
17-5/8	3	15	4-1/4	5	1-1/2	0	BB-4	SWSF-216
17-7/8	2-5/8	15	4-1/4	5	1-3/4	1-1/4	BB-1	SWSF-1-177
18	2-1/4	12	3	5-7/8	1	3/4	BB-1	SBBF-18
18	3	12	4-1/4	5	1-3/4	1-3/4	BB-6	SWSF-2-180
18	3	18	4-1/4	5	1-3/4	0	BB-5	SWSF-3-180
18	3	15	4-1/4	5	1-1/2	1-5/8	BB-1	SWSF-214
19	3-1/4	12	5-5/8	6-1/8	2-1/4	7/8	BB-2	SWSF-218
20-3/4	3-1/2	16	5	5-3/4	2-1/8	0	BB-5	SWSF-3-206
20-3/4	3-1/2	16	5-1/4	6	2-1/8	0	BB-1	SWSF-230

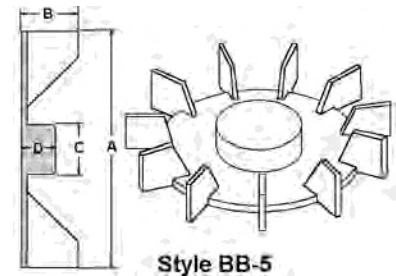

Style BB-5

Modern foreign and American motor designs often have squared-off or flat end bells, so no recess is required in the fan's hub area. These fans can be used on many Baldor, GE, Toshiba and other brands.

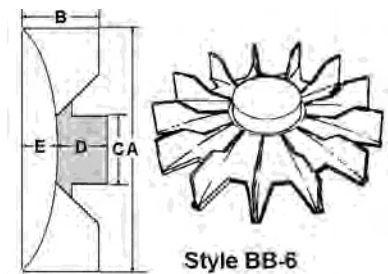

Style BB-6

The Style BB-6 fan will vary from Style BB-1 only in that it has a deeper recess to better wrap around the end bell, and protruding bearing housings.

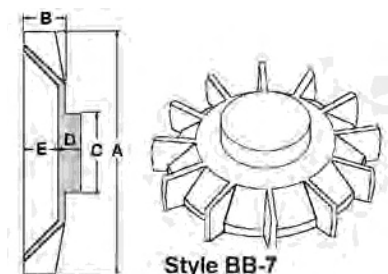

Style BB-7

Series BB-7 fans have a deep hub recess, typically used on many European motors and some older American designs.

Essex Brownell has many other blank bore fans available. Please supply us with the dimensions of the fan you need and we'll be happy to get it for you.

SYNFLEX YELLOW BLADE FANS

Get the original universal replacement cooling fan. Synflex has the experience that provides the highest quality fans in this style. Yellow blade fans are excellent replacement for OEM fans. Their unique hub system allows you to quickly and easily replace most fans. In most cases you will find that the yellow blade fans delivers more air flow that the original fan. The light weight plastic material doesn't create an unbalance problem. Fins are easily trimmed to size if the fins are too high.

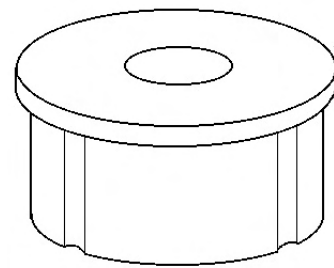
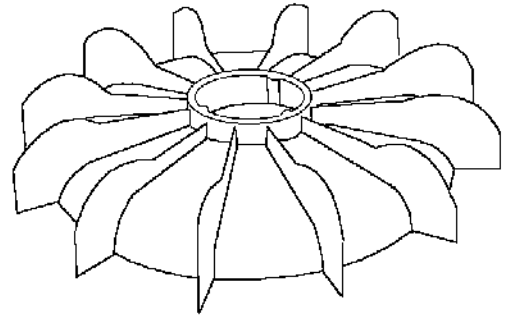

YELLOW BLADE FAN SELECTION CHART

O.D. (IN.)	FANS BLADE HEIGHT	PART NUMBER	INCH SIZE I.D. (IN.)	BUSHINGS		PART NUMBER	METRIC SIZE BUSHINGS			
				KEYWAY 1 (IN.)	KEYWAY 2 (IN.)		I.D. (MM X IN.)	KEYWAY 1 (IN.)	KEYWAY 2 (IN.)	PART NUMBER
4-7/8	1-1/32	FCS-71	1/4	-	-	FCS-71-80-0	14 - .547	6-.236	4-.157	FCS-71-80-14
			1/2	3/16	1/8	FCS-71-80-4	16 - .626	6-.236	4-.157	FCS-71-80-16
			5-3/16	3/16	1/8	FCS-71-80-5	19 - .742	6-.236	4-.157	FCS-71-80-19
5-3/16	1-1/32	FCS-80	5/8	3/16	1/8	FCS-71-80-5	20 - .782	6-.236	4-.157	FCS-71-80-20
							22 - .861	6-.236	4-.157	FCS-71-80-22
6-9/16	1-9/32	FCS-90	1/2	-	-	FCS-90-100-4				
			5/8	3/16	1/8	FCS-90-100-5	24 - .940	8-.315	6-.236	FCS-90-100-24
			11/16	-	-	FCS-90-100-0	25 - .980	8-.315	6-.236	FCS-90-100-25
6-3/4	1-7/16	FCS-100	3/4	3/16	1/8	FCS-90-100-6	30 - 1.177	8-.315	6-.236	FCS-90-100-30
			7/8	1/4	3/16	FCS-90-100-7				
8-1/2	1-13/16	FCS-112	3/4	-	-	FCS-112-132-0	28 - 1.098	10-.394	8-.315	FCS-112-132-28
			7/8	1/4	3/16	FCS-112-132-7	30 - 1.177	10-.394	8-.315	FCS-112-132-30
							32 - 1.255	10-.394	8-.315	FCS-112-132-32
9-11/16	2-3/16	FCS-132	1-1/8	1/4	3/16	FCS-112-132-9	40 - 1.570	10-.394	8-.315	FCS-112-132-40
			1-3/8	5/16	1/4	FCS-112-132-11	45 - 1.757	10-.394	8-.315	FCS-112-132-45
11-3/4	2-3/16	FCS-160	1-1/8	-	-	FCS-160-180-0	42 - 1.649	11-.433	10-.394	FCS-160-180-42
			1-3/8	5/16	1/4	FCS-160-180-11	45 - 1.767	12-.472	10-.394	FCS-160-180-45
13-1/8	2-3/16	FCS-180	1-5/8	3/8	1/4	FCS-160-180-13	50 - 1.964	12-.472	10-.394	FCS-160-180-50
			1-7/8	1/2	1/4	FCS-160-180-15				

SYNCROSNAP ROTATING MECHANISMS

For this catalog the rotating mechanisms have been broken down into three basic groups.

- 1.) Syncrosnap style.
- 2.) Shaft-end mount style.
- 3.) Fly-weight style.

BACKPLATE SERIES CHART

SERIES	O.D. (IN.)	MATERIAL
150	2.25	Steel
170	2.42	Steel
200	2.61	Steel

SERIES	O.D. (IN.)	MATERIAL
240	2.78	Plastic
241	2.78	Plastic
250	2.78	Steel

SERIES	O.D. (IN.)	MATERIAL
260	2.98	Plastic
300	3.56	Steel

1.) **Syncrosnap** mechanisms feature a round back plate design with either 3 or 6 weights. Sometimes referred to as Torq style mechanisms. When identifying Syncrosnap mechanisms, 3 specifications need to be examined: inside diameter or bore size, spool outside diameter, and cut-out RPM rating. The progressive size chart has been grouped into bore sizes rounded to the nearest 64th of an inch. By matching the letter code found on the backplate to the code indicated in the progressive chart, you can be sure of getting the correct bore size for the application. There are a couple of instances where the letter code has different tolerances based on which size backplate is being used. To match up the backplate series listed in the progressive size listing, compare the outside diameter with the sizes listed in the backplate series chart.

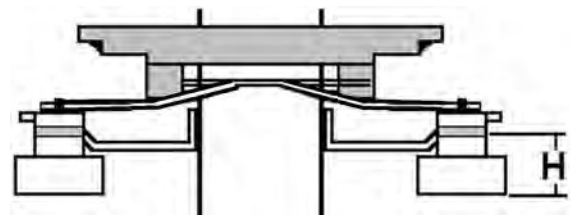

Figure A

Once the proper backplate and bore size have been determined, the next consideration is the spool diameter and height. Now the RPM rating of the switch must be selected, the progressive size chart list the number of poles of the motor and the frequency that the motor will operate on. I.E. 2P60 indicates a 2 pole (3600) RPM motor operating on 60 cycles. Lastly the weight size should be matched up. The progressive size chart lists the weight size as diameter x length. The number stamped on the weight indicates the length of the weight that extends out from the bottom of the mounting washer, see figure A.

Three weight mechanisms can be substituted with six weight mechanisms or six weights can be replaced by three weights provided there is enough room to allow the weight to move freely.

2.) **Shaft - end** mount mechanisms are typically found on pump motors that utilize a two compartment design where the switch and normally replaced components can be accessed by removing a cover on the end of the motor. Most of these mechanisms use a button to press against the stationary switch, except for one style that was used by Flint & Walling that was a Syncrosnap style mechanism with a special spool. A.O. Smith also used a design that had a spool on it.

3.) **Flyweight** mechanisms use weights and a coil spring to actuate the switch. These mechanisms are usually unique in design to the manufacturer that uses them. The progressive size chart lists the bore of the mechanism and the largest dimension that would swing when the mechanism is in a stationary position. RPM is indicated by the poles of the motor and the frequency at which the motor was designed to operate.

If the mechanism to be replaced isn't found in this catalog, please provide as many dimensions as possible and the nameplate data of the motor being repaired.

SYNCROSNAP ROTATING MECHANISMS

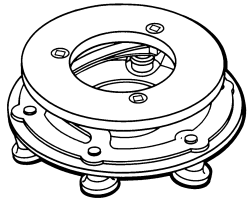

RM-A

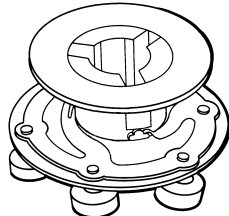

RM-B

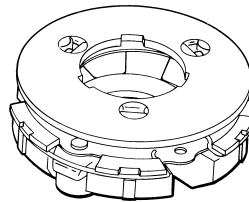

RM-C

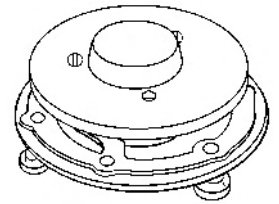

RM-D

BORE CODE (IN.)	BACKPLATE SERIES	SPOOL I.D. (IN.)	SPOOL O.D. (IN.)	# OF WEIGHTS	WEIGHT SIZE	# OF POLES/HZ	PHOTO REF.	PART NUMBER
1/4" x 1/2" Rectangular Bore								
.250 x .500	200	1-1/8	2-1/4	3/Z	1/2"X.230	2P60	RM-A	SLF-2-36
5/8" Bore								
C (.615)	150	13/16	1-27/32	3/B	1/2"X.275	4P60	RM-A	SDO-7-17
C (.615)	150	13/16	1-27/32	3/B	3/8"X.120	2P60	RM-A	SDO-7-36
C (.615)	200	1-1/8	2-1/4	3/Z	5/8"X.420	4P60	RM-A	SOH-47-17
41/64" Bore								
3 (.637)	250	1	1-7/8	6/B	9/16"X.440	6P60	RM-A	SWH-357-11
3 (.637)	250	1	1-7/8	6/B	9/16"X.440	4P60	RM-A	SWH-357-17
3 (.637)	250	1	1-7/8	3/B	7/16"X.274	2P60	RM-A	SWH-357-36
3 (.637)	250	1	2-3/8	6/B	9/16"X.440	6P60	RM-A	SWH-402-11
3 (.637)	250	1	2-3/8	3/B	9/16"X.440	4P60	RM-A	SWH-402-17
3 (.637)	250	1	2-3/8	3/B	7/16"X.274	2P60	RM-A	SWH-402-36
43/64" Bore								
Z (.667)	200	1-1/8	2-1/4	6/Z	5/8"X.295	4P60	RM-A	SAW-34-17
Z (.667)	200	1-1/8	2-1/4	3/Z	1/2"X.260	2P60	RM-A	SFW-10-36
11/16" Bore								
2 (.688)	250	1	2-3/8	6/B	9/16"X.40	6P60	RM-A	SWH-435-11
T (.688)	250	1	2-3/8	3/Z	5/8"X.420	4P60	RM-A	SWH-435-17
2 (.688)	250	1	2-3/8	3/B	7/16"X.274	2P60	RM-A	SWH-435-36
2 (.688)	250	1	2-3/8	6/B	9/16"X.440	6P60	RM-A	SWH-438-11
47/64" Bore								
F (.729)	200	1-1/8	2-1/4	3/Z	5/8"X.420	4P60	RM-A	SDO-2-17
F (.729)	200	1-1/8	2-1/4	3/Z	1/2"X.230	2P60	RM-A	SDO-2-36
3/4" Bore								
D (.748)	170	11/16	1-7/8	3/Z	1/2"X.200	2P60	RM-D	SFW-12-36
H (.737)	200	31/32	1-3/4	3/Z	5/8"X.420	4P60	RM-A	SOH-56-17
H (.737)	200	31/32	1-3/4	3/Z	1/2"X.260	2P60	RM-A	STO-2-36
H (.737)	200	3/4-Ext	2-1/4	6/Z	5/8"X.420	4P60	RM-B	SDO-9-17
A (.745)	200	1-1/8	2-1/4	6/Z	5/8"X.420	6P60	RM-A	SFK-24-11
A (.745)	200	1-1/8	2-1/4	6/Z	5/8"X.295	4P60	RM-A	SFK-24-17
A (.745)	200	1-1/8	2-1/4	6/Z	5/8"X.280	4P/2P60	RM-A	SFK-24-17-36
A (.745)	200	1-1/8	2-1/4	3/Z	1/2"X.230	2P60	RM-A	SFK-24-36
H (.737)	200	1-1/8	2-1/4	3/Z	1/2"X.260	2P60	RM-A	SFW-7-36
U (.742)	200	1-1/8	2-1/4	3/B	3/8"X.270	2P60	RM-A	SKC-30-36
U (.742)	200	1-1/8	2-1/4	6/Z	5/8"X.390	4P60	RM-A	SKC-41-17
U (.742)	200	1-1/8	2-1/4	6/Z	5/8"X.420	6P60	RM-A	SKC-44-11
U (.742)	200	1-1/8	2-1/4	6/Z	5/8"X.295	4P60	RM-A	SKC-45-17
H (.737)	200	1-1/8	2-1/4	6/Z	5/8"X.420	6P60	RM-A	SLS-3-12
H (.737)	200	1-1/8	2-1/4	6/Z	5/8"X.325	4P50	RM-A	SLS-3-15
H (.737)	200	1-1/8	2-1/4	6/Z	5/8"X.280	4P60	RM-A	SLS-3-18
H (.737)	200	1-1/8	2-1/4	3/Z	1/2"X.230	2P60	RM-A	SLS-3-36
H (.737)	200	1-1/8	2-1/4	6/Z	5/8"X.420	6P60	RM-A	SMA-133-11
H (.737)	200	1-1/8	2-1/4	3/Z	5/8"X.420	4P60	RM-A	SMA-133-17
H (.737)	200	1-1/8	2-1/4	3/Z	1/2"X.260	2P60	RM-A	SMA-133-36
H (.737)	200	1-1/8	2-1/4	6/Z	5/8"X.420	6P60	RM-A	SMA-173-11

SYNCROSNAP ROTATING MECHANISMS

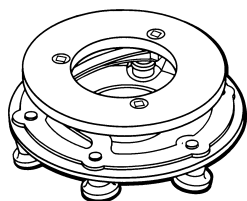

RM-A

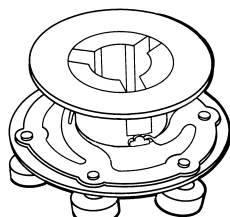

RM-B

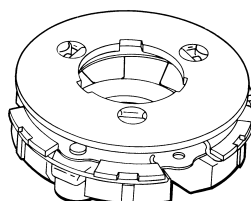

RM-C

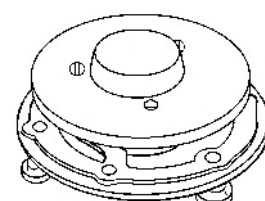

RM-D

BORE CODE (IN.)	BACKPLATE SERIES	SPOOL I.D. (IN.)	SPOOL O.D. (IN.)	# OF WEIGHTS	WEIGHT SIZE	# OF POLES/HZ	PHOTO REF.	PART NUMBER
3/4" Bore								
.250 x .500	200	1-1/8	2-1/4	3/Z	1/2"X.230	2P60	RM-A	SLF-2-36
H (.737)	200	1-1/8	2-1/4	6/Z	1/2"X.325	4P60	RM-A	SMA-173-17
H (.737)	200	1-1/8	2-1/4	3/Z	1/2"X.230	2P60	RM-A	SMA-173-36
H (.737)	200	1-1/8	2-1/4	3/Z	9/16"X.420	4P60	RM-A	SOH-46-17
B (.752)	200	31/32	1-3/4	3/Z	5/8"X.420	4P60	RM-A	SPQ-3-17
B (.752)	200	1-1/8	2-1/4	6/Z	5/8"X.280	4P60	RM-A	SPL-105-17
13/16" Bore								
J (.812)	200	1-1/8	2-1/4	6/Z	5/8"X.295	4P60	RM-A	SPL-106-17
J (.812)	200	1-1/8	2-1/4	3/Z	1/2"X.260	2P60	RM-A	SPL-106-36
J (.812)	200	1-1/8	2-3/4	3/Z	5/8"X.420	4P60	RM-A	SJH-11-17
J (.812)	200	1-1/8	2-3/4	6/Z	5/8"X.295	4P60	RM-A	SPL-107-17
55/64" Bore								
1 (.858)	250	1	1-7/8	3/B	9/16"X.440	4P60	RM-A	SWH-394-17
1 (.858)	250	1	1-7/8	3/B	9/16"X.519	4P60	RM-A	SWH-406-17
S (.858)	200	1-1/8	2-1/4	6/Z	5/8"X.420	6P60	RM-A	SMA-174-11
S (.858)	200	1-1/8	2-1/4	6/Z	5/8"X.280	4P60	RM-A	SMA-174-17
S (.858)	200	1-1/8	2-1/4	3/Z	1/2"X.230	2P60	RM-A	SMA-174-36
U (.858)	250	1	2-3/8	6/Z	5/8"X.295	4P60	RM-A	SWH-403-17
1 (.858)	250	1	2-3/8	6/B	9/16"X.440	6P60	RM-A	SWH-430-11
7/8" Bore								
P (.869)	200	7/8-Ext	2	6/Z	5/8"X.420	4P60	RM-B	SDO-17-17
P (.869)	200	1-1/8	2-1/4	6/Z	5/8"X.502	6P60	RM-A	SDO-5-11
P (.869)	200	1-1/8	2-1/4	6/Z	5/8"X.295	4P60	RM-A	SDO-5-17
P (.869)	200	1-1/8	2-1/4	6/B	T X.455	4P60	RM-A	SDO-5-17T
P (.869)	200	1-1/8	2-1/4	3/Z	1/2"X.230	2P60	RM-A	SDO-5-36
M (.870)	200	1-1/8	2-1/4	3/Z	5/8"X.420	4P60	RM-A	SELC-3-17
P (.869)	200	1-1/8	2-1/4	6/Z	5/8"X.420	4P60	RM-A	SGE-1005-17
P (.869)	200	1-1/8	2-3/4	6/Z	5/8"X.502	6P60	RM-A	SDO-12-11
P (.869)	200	1-1/8	2-3/4	6/Z	5/8"X.295	4P60	RM-A	SDO-12-17
P (.869)	200	1-1/8	2-3/4	6/B	3/8"X.120	2P60	RM-A	SDO-12-36
P (.869)	200	1-1/8	2-3/4	6/B	9/16"X.490	8P60	RM-A	SDO-12-8
P (.869)	200	1-1/8	2-3/4	6/Z	5/8"X.280	4P60	RM-A	SLS-5-18
15/16" Bore								
N (.932)	200	1-1/8	2-3/4	6/Z	5/8"X.295	4P60	RM-A	SKC-32-17
N (.932)	200	1-1/8	2-3/4	3/Z	5/8"X.420	4P60	RM-A	SVA-11-17
N (.932)	200	1-1/8	2-3/4	3/Z	1/2"X.260	2P60	RM-A	SVA-11-36
63/64" Bore								
AM (.985)	200	1-1/8	2-1/4	6/Z	5/8"X.420	6P60	RM-A	SMA-122-11
AM (.985)	200	1-1/8	2-1/4	6/Z	5/8"X.280	4P60	RM-A	SMA-122-17
AM (.985)	200	1-1/8	2-1/4	3/Z	1/2"X.230	2P60	RM-A	SMA-122-36
AM (.985)	200	1-1/8	2-3/4	3/Z	1/2"X.260	2P60	RM-A	SDO-27-36
AM (.985)	200	1-1/8	2-3/4	6/Z	5/8"X.280	4P60	RM-A	SMA-247-17
AM (.985)	200	1-1/8	2-3/4	3/Z	1/2"X.230	2P60	RM-A	SMA-247-36

SYNCROSNAP ROTATING MECHANISMS

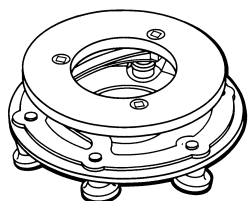

RM-A

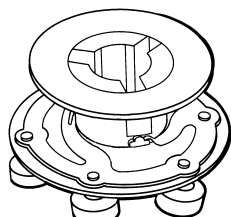

RM-B

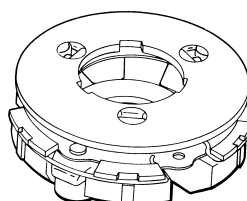

RM-C

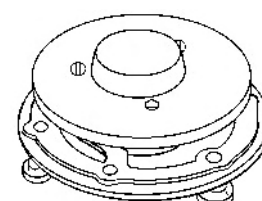

RM-D

BORE CODE (IN.)	BACKPLATE SERIES	SPOOL I.D. (IN.)	SPOOL O.D. (IN.)	# OF WEIGHTS	WEIGHT SIZE	# OF POLES/HZ	PHOTO REF.	PART NUMBER
				63/64" Bore				
D (.983)	260	1-1/4	2-13/16	3/Pb	-	4P60	RM-C	SMA-221-17
D (.983)	260	1-1/4	2-13/16	3/Pb	-	2P60	RM-C	SMA-221-36
				1" Bore				
AA (1.003)	300	1-3/4	2-7/8	6/Z	5/8"X.390	4P60	RM-A	SPL-114-17
				1-1/16" Bore				
AB (1.05)	300	1-3/4	2-7/8	6/Z	5/8"X.390	4P60	RM-A	SDO-4-17
AB (1.05)	300	1-3/4	2-7/8	6/Z	3/8"X.200	2P60	RM-A	SDO-4-36
				1-1/8" Bore				
AC (1.127)	300	1-3/4	2-7/8	6/Z	1/2"X.200	2P60	RM-A	SMR-103-36
AC (1.127)	300	1-3/4	2-7/8	6/Z	5/8"X.390	4P60	RM-A	SUS-33-17
				1-11/64" Bore				
AJ (1.168)	300	1-3/4	2-7/8	6/Z	5/8"X.390	4P60	RM-A	SGE-758-17
AJ (1.168)	300	1-3/4	2-7/8	6/Z	1/2"X.260	2P60	RM-A	SGE-758-36
				1-3/16" Bore				
AD (1.187)	300	1-3/4	3-9/16	6/Z	5/8"X.420	4P60	RM-A	SMA-197-17
AD (1.187)	300	1-3/4	3-9/16	6/Z	1/2"X.230	2P60	RM-A	SMA-197-36
				1-1/4" Bore				
AE (1.231)	300	1-3/4	2-7/8	6/Z	1/2"X.260	2P60	RM-A	SDO-29-36
AE (1.231)	300	1-3/4	2-7/8	6/Z	5/8"X.390	4P60	RM-A	SKC-35-17
AE (1.231)	300	1-3/4	2-7/8	6/Z	5/8"X.325	4P60	RM-A	SWH-110-17
AE (1.231)	300	1-3/4	2-7/8	6/Z	1/2"X.230	2P60	RM-A	SWH-110-36
				1-21/64" Bore				
AN (1.325)	300	1-3/4	2-7/8	6/Z	5/8"X.502	6P60	RM-A	SLS-9-12
AN (1.325)	300	1-3/4	2-7/8	6/Z	5/8"X.390	4P60	RM-A	SLS-9-18
AN (1.325)	300	1-3/4	3-9/16	6/Z	5/8"X.390	4P60	RM-A	SLS-25-18
				1-23/64" Bore				
CC (1.356)	300	1-3/4	3-1/4	6/Z	5/8"X.390	4P60	RM-A	SGE-1113-17
CC (1.356)	300	1-3/4	3-1/4	6/Z	1/2"X.200	2P60	RM-A	SGE-1113-36
				1-3/8" Bore				
AF (1.375)	300	1-3/4	3-9/16	6/Z	5/8"X.390	4P60	RM-A	SKC-40-17
				1-29/64" Bore				
AL (1.443)	300	1-3/4	3-9/16	6/Z	5/8"X.390	4P60	RM-A	SCN-453-17
AL (1.443)	300	1-3/4	3-9/16	6/Z	1/2"X.230	2P60	RM-A	SCN-453-36
AL (1.443)	300	1-3/4	3-9/16	6/Z	5/8"X.390	4P60	RM-A	SUS-34-17
				1-31/64" Bore				
AH (1.478)	300	1-3/4	2-7/8	6/B	9/16"X.625	6P60	RM-A	SMR-55-11
AH (1.478)	300	1-3/4	2-7/8	6/Z	5/8"X.295	4P60	RM-A	SMR-55-17
AH (1.478)	300	1-3/4	2-7/8	6/Z	1/2"X.200	2P60	RM-A	SMR-55-36
AH (1.478)	300	1-3/4	3-1/4	6/Z	5/8"X.325	4P60	RM-A	SWH-111-17
AH (1.478)	300	1-3/4	3-9/16	6/Z	5/8"X.390	4P60	RM-A	SPL-112-17
AH (1.478)	300	1-3/4	3-9/16	6/Z	9/16"X.502	6P60	RM-A	SWH-356-11
AH (1.478)	300	1-3/4	3-9/16	6/Z	5/8"X.325	4P60	RM-A	SWH-356-17
				1-39/64" Bore				
AK (1.597)	300	1-3/4	2-7/8	6/Z	5/8"X.390	4P60	RM-A	SGE-760-17
AP (1.605)	300	1-3/4	3-1/4	6/Z	5/8"X.390	4P60	RM-A	SGE-1115-17
AP (1.605)	300	1-3/4	3-1/4	6/Z	1/2"X.200	2P60	RM-A	SGE-1115-36

SHAFT-END MOUNT & FLYWEIGHT ROTATING MECHANISMS

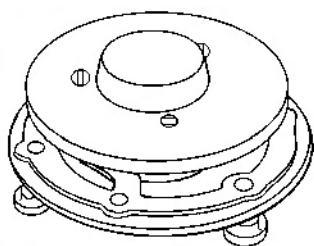

RM-D

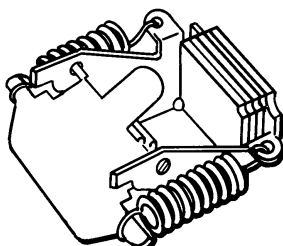

RM-E



RM-F

BORE CODE (IN.)	MECH. O.D. (IN.)	SPOOL I.D. (IN.)	SPOOL O.D. (IN.)	# OF POLES/HZ	PHOTO REF.	PART NUMBER
1/4 X1/2	1-3/4	-	-	4P60	RM-E	SAW-21-17
1/4 X1/2	1-3/4	-	-	2P60	RM-E	SAW-21-36
1/4 X1/2	1-13/16	-	-	2P/4P60	RM-E	SAW-47-36-17
1/4 X1/2	1-7/8	-	-	2P60	RM-E	SGE-1117-36
1/4 X1/2	1-3/4	-	-	2P/4P60	RM-E	SGE-1134-36-17
11/16 (.669)	2-1/4	-	-	2P60	RM-F	SFW-15-36
D (.748)	2-27/64	11/16	1-7/8	2P60	RM-D	SFW-12-36

FLYWEIGHT ROTATING MECHANISMS

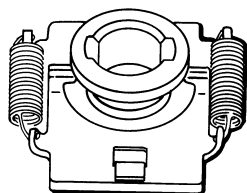

RM-G

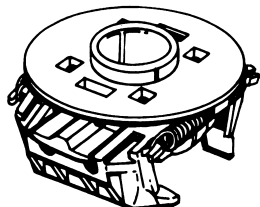

RM-H

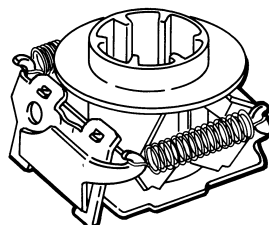

RM-I

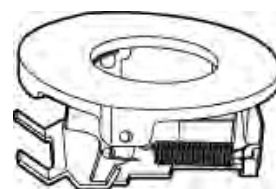

RM-J

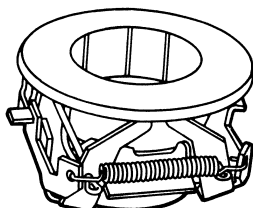

RM-K

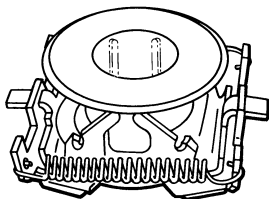

RM-L

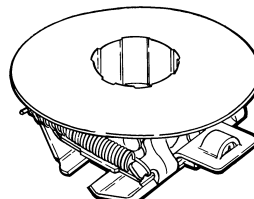

RM-M

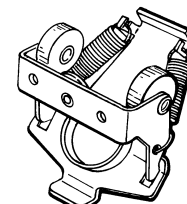

RM-N

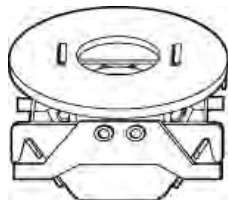

RM-O

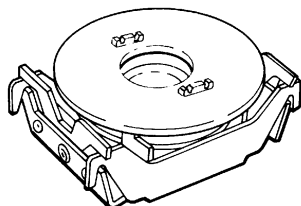

RM-P

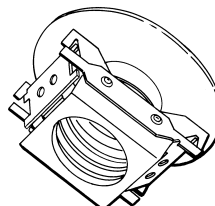

RM-Q

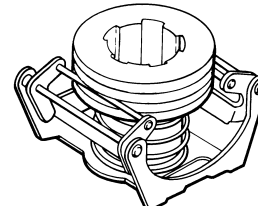

RM-R

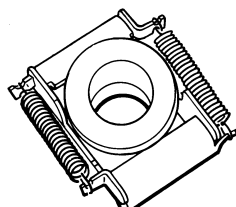

RM-S

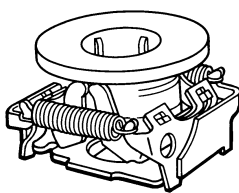

RM-T

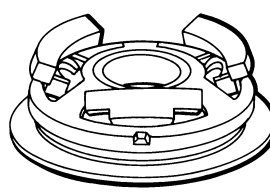

RM-U

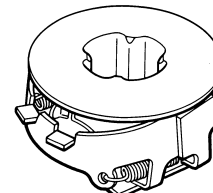

RM-V

FLYWEIGHT ROTATING MECHANISMS

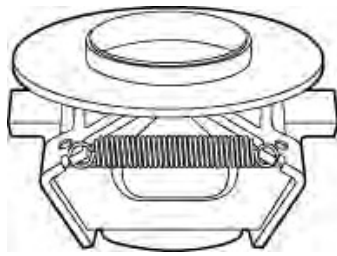

RM-W

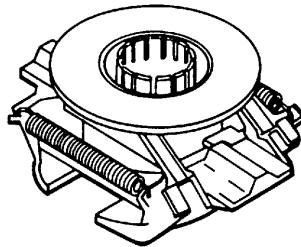

RM-X

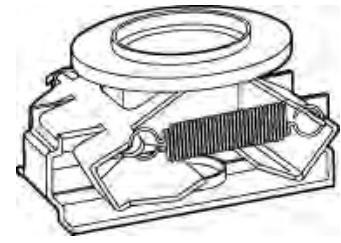

RM-Y

BORE CODE (IN.)	MECH. O.D. (IN.)	SPOOL I.D. (IN.)	SPOOL O.D. (IN.)	# OF POLES/HZ	PHOTO REF.	PART NUMBER
33/64	2-7/16	3/4	1-15/32	2P60	RM-X	SEM-409-36
39/64	1-3/4	29/32	2	4P60	RM-U	SBO-16-17
5/8	2-3/16	21/32	1-1/8	4P60	RM-G	SGE-22-17
5/8	2-3/16	21/32	1-1/8	2P60	RM-G	SGE-22-36
5/8	2-3/8	5/8	1-1/4	4P60	RM-S	SMR-53-17
5/8	2-3/8	5/8	1-1/4	2P60	RM-S	SMR-53-36
5/8	2-5/8	5/8	1-1/2	4P60	RM-R	SBG-2-17
5/8	2-1/4	11/16	1-1/2	4P60	RM-Y	SWH-546-17
21/32	2-1/4	5/8	1-13/16	4P60	RM-I	SGE-998-17
21/32	2-1/4	13/16	2	4P50	RM-H	SGE-1145-15
21/32	2-1/4	13/16	2	4P60	RM-H	SGE-1145-17
21/32	2-1/4	13/16	2	4P/6P60	RM-H	SGE-1145-17/11
21/32	2-1/4	13/16	2	2P60	RM-H	SGE-1145-36
21/32	2-1/4	13/16	2	2P/4P60	RM-H	SGE-1145-36-17
21/32	2-1/4	7/8	2	2P60	RM-H	SGE-1170-36
11/16	2-1/2	3/4	2-7/16	2P60	RM-L	SCN-388-36
45/64	2-1/4	23/32	1-7/8	4P60	RM-I	SGE-1114-17
45/64	2-1/4	23/32	1-7/8	2P60	RM-I	SGE-1114-36
3/4	2-7/8	3/4	1-3/8	6P60	RM-S	SMR-2-11
3/4	2-7/8	3/4	1-3/8	4P60	RM-S	SMR-2-17
3/4	2-7/8	3/4	1-3/8	2P60	RM-S	SMR-2-36
3/4	2-13/16	3/4	1-5/8	4P60	RM-R	SBG-14-17
3/4	2-7/8	3/4	1-3/4	6P60	RM-L	SCN-435-11
3/4	2-7/8	3/4	1-3/4	4P60	RM-L	SCN-435-17
3/4	2-9/16	3/4	1-3/4	2P60	RM-L	SCN-435-36
3/4	2-9/16	3/4	1-3/4	2P/4P60	RM-L	SCN-435-36-17
3/4	2-7/8	3/4	1-3/4	8P60	RM-L	SCN-435-9
3/4	27/32	55/64	1-7/8	6P60	RM-T	SGE-573-12
3/4	2-1/8	3/4	2	4P60	RM-V	SWA-447-17
3/4	2-7/16	3/4	2-1/4	6P60	RM-M	SLS-10-12
3/4	2-7/16	3/4	2-1/4	4P60	RM-M	SLS-10-18
3/4	2-7/16	3/4	2-1/4	2P60	RM-M	SLS-10-36
3/4	2-9/16	1-1/16 X1-5/16	2-1/2	4P60	RM-J	SFK-55-17
3/4	2-9/16	1-1/16 X1-5/16	2-1/2	2P/4P60	RM-J	SFK-55-17-36
3/4	2-9/16	1-1/16 X1-5/16	2-1/2	2P/4P60	RM-J	SFK-55-30
3/4	2-9/16	1-1/16 X1-5/16	2-1/2	2P60	RM-J	SFK-55-36
3/4	2-1/4	-	-	6P60	RM-N	SFK-3-11
3/4	2-1/4	-	-	4P60	RM-N	SFK-3-17
3/4	2-1/4	-	-	2P60	RM-N	SFK-3-36
3/4	2-3/8	-	-	6P60	RM-N	SFK-8-11
13/16	2-7/16	13/16	2-3/16	6P60	RM-O	SBA-63-11
13/16	2-7/16	13/16	2-3/16	4P60	RM-O	SBA-63-17
13/16	2-7/16	13/16	2-3/16	2P60	RM-O	SBA-63-36
13/16	3-1/8	13/16	2-3/16	4P60	RM-P	SBA-94-17
13/16	3-1/8	13/16	2-3/16	2P60	RM-P	SBA-94-36
7/8	2-11/16	15/16	2-1/16	6P50	RM-T	SGE-576-10

FLYWEIGHT ROTATING MECHANISMS

BORE CODE (IN.)	MECH. O.D. (IN.)	SPOOL I.D. (IN.)	SPOOL O.D. (IN.)	# OF POLES/HZ	PHOTO REF.	PART NUMBER
7/8	2-1/2	15/16	2-1/16	6P60	RM-T	SGE-576-12
7/8	2-1/2	15/16	2-1/16	4P60	RM-T	SGE-576-17
7/8	2-1/2	15/16	2-1/16	4P/6P60	RM-T	SGE-576-17-11
7/8	2-1/2	15/16	2-1/16	2P60	RM-T	SGE-576-36
7/8	2-11/16	15/16	2-1/16	8P60	RM-T	SGE-576-8
7/8	2-1/4	-	-	6P60	RM-N	SFK-4-11
7/8	2-1/4	-	-	4P60	RM-N	SFK-4-17
7/8	2-1/4	-	-	2P60	RM-N	SFK-4-36
15/16	2-1/2	1	2-3/8	2P60	RM-L	SCN-389-36
1-1/8	3-1/4	1-1/8	2-3/4	4P60	RM-K	SCN-498-17
1-1/8	3-1/4	1-1/8	2-3/4	2P60	RM-K	SCN-498-36
1-1/8	3-5/8	1-1/8	3-11/16	6P60	RM-Q	SBA-67-11
1-1/8	3-5/8	1-1/8	3-11/16	4P60	RM-Q	SBA-67-17
1-1/8	3-5/8	1-1/8	3-11/16	2P60	RM-Q	SBA-67-36
1-1/4	3-1/2	1-3/8	2-7/8	4P60	RM-W	SDO-41-17
1-3/8	3-5/8	1-7/16	3-11/16	6P60	RM-Q	SBA-70-11
1-3/8	3-5/8	1-7/16	3-11/16	4P60	RM-Q	SBA-70-17
1-3/8	3-5/8	1-7/16	3-11/16	2P60	RM-Q	SBA-70-36
1-7/16	3-1/4	1-1/2	2-3/4	6P60	RM-K	SCN-440-11
1-7/16	3-1/4	1-1/2	2-3/4	4P60	RM-K	SCN-440-17
1-7/16	3-1/4	1-1/2	2-3/4	2P60	RM-K	SCN-440-36
1-7/16	3-1/4	1-1/2	3-1/2	6P60	RM-K	SCN-444-11
1-7/16	3-1/4	1-1/2	3-1/2	4P60	RM-K	SCN-444-17
1-7/16	3-1/4	1-1/2	3-1/2	2P60	RM-K	SCN-444-36

FLYWEIGHT ROTATING SPOOLS

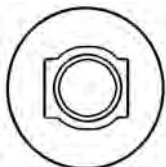

RMS-A

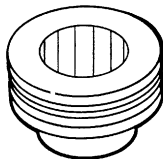

RMS-B

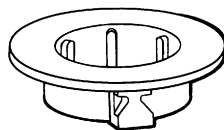

RMS-C

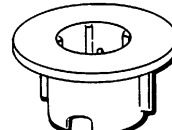

RMS-E

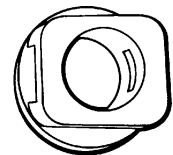

RMS-G

MECHANISM SERIES	SPOOL I.D. (IN.)	SPOOL O.D. (IN.)	PHOTO REF.	SPOOL PART NUMBER
SBA-67 Series	1-1/8	3-11/16	RMS-A	SBA-113
SBA-94 Series	13/16	2-3/16	RMS-A	SBA-114
SBG-14-17	3/4	1-5/8	RMS-B	SBG-15
SBG-2-17	5/8	1-1/2	RMS-B	SBG-3
SCN-435 Series	3/4	1-3/4	RMS-C	SCN-436
SCN-440 Series	1-1/2	2-3/4	RMS-C	SCN-441

MECHANISM SERIES	SPOOL I.D. (IN.)	SPOOL O.D. (IN.)	PHOTO REF.	SPOOL PART NUMBER
SCN-444 Series	1-1/2	3-1/2	RMS-C	SCN-450
SCN-498 Series	1-1/8	2-3/4	RMS-C	SCN-522
SGE-576 Series	15/16	2-1/16	RMS-E	SGE-589
SMR-2 Series	3/4	1-3/8	RMS-G	SMR-3
SMR-53 Series	5/8	1-1/4	RMS-G	SMR-35

BEARING ACCESSORIES

USA TOLERANCE RINGS

Tolerance rings are a quick and easy method of rebuilding bearing housings. Simply determine the bearing series or width and O.D. of bearing. Select the tolerance ring. Check the maximum radial load rating. Keep in mind, over hung loads, as in a belt drive application can increase radial load by as much as 30%. Bore the housing the recommended bore. Install the tolerance ring in the housing and assembly as usual. To avoid damage to the bearing or tolerance ring, the housing must be kept square with the shaft at all times.

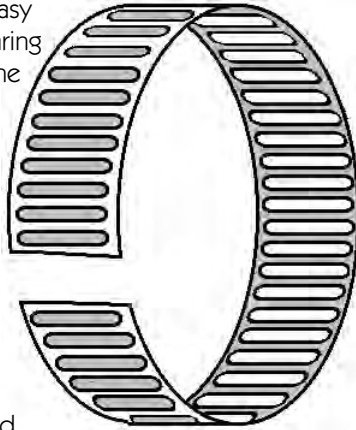

BEARING SERIES	BEARING O.D. (IN.)	RECOMMENDED BEARING HOUSING BORE (IN.)	BEARING WIDTH (IN.)	MAXI. RADIAL LOAD (LBS.)	PART NUMBER
200	1.1811	1.259/1.257	0.3543	980	TR6200
201	1.2598	1.338/1.336	0.3937	670	TR6201
202-300	1.378	1.456/1.454	0.4331	820	TR6202
301	1.4567	1.5347/1.5327	0.4724	940	TR6301
203	1.5748	1.653/1.661	0.4724	1000	TR6203
302	1.6535	1.731/1.7929	0.5118	1200	TR6302
204-303	1.8504	1.928/1.924	0.5512	1400	TR6204
205-304	2.0472	2.145/2.143	0.5906	1600	TR6205
206-305	2.4409	2.538/2.536	0.6299	2000	TR6206
207	2.8346	2.9129/2.9119	0.6693	2900	TR6207
305	2.8346	2.9129/2.9119	0.748	3200	TR6305
208	3.1496	3.2279/3.2269	0.7087	3200	TR6208
307	3.1496	3.2279/3.2269	0.8226	3700	TR6307
209	3.3465	3.4248/3.4238	0.748	3800	TR6209
210	3.5433	3.6216/3.6206	0.7874	4200	TR6210
308	3.5433	3.6216/3.6206	0.9055	4600	TR6308
211	3.937	4.054/4.052	0.8268	4500	TR6211
309	3.937	4.0153/4.0143	0.9843	4900	TR6309
212	4.3307	4.4090/4.408	0.8661	5600	TR6212
310	4.3307	4.4090/4.4080	1.063	6400	TR6310
213	4.7244	4.8027/4.8017	0.9055	5200	TR6213
311	4.7244	4.8027/4.8017	1.1417	7000	TR6311
214	4.9213	4.9996/4.9986	0.9449	6400	TR6214
215	5.1181	5.1964/5.1954	0.9843	7600	TR6215
312	5.1181	5.1964/5.1954	1.2025	9400	TR6312
216	5.5118	5.5901/5.5891	1.0236	8200	TR6216
313	5.5118	5.5901/5.5891	1.2992	10800	TR6313
217	5.9055	5.9838/5.9828	1.1024	8600	TR6217
314	5.9055	5.9838/5.9828	1.378	11600	TR6314
218	6.2992	6.3775/6.3765	1.1811	9300	TR6218
315	6.2992	6.3775/6.3765	1.4567	12300	TR6315
316	6.6929	6.7712/6.7702	1.5354	15500	TR6316
317	7.0866	7.1649/7.1639	1.6142	16400	TR6317
318	7.4803	7.5586/7.5576	1.6979	17300	TR6318

END BELL REPAIR SLEEVES

Cast iron end bell repair sleeves are an economical method of repairing worn end bells. Simply machine the worn end bell to accept the bearing sleeve. Insert the sleeve and finish machine the sleeve to the appropriate fit and length for the bearing.

BEARING SIZE	I.D. (IN.)	O.D. (IN.)	LENGTH	PART NUMBER
203	1.52	1.80	0.875	PM-6203
204/303	1.82	2.10	0.875	PM-6204
205/304	1.97	2.25	0.875	PM-6205
206/305	2.34	2.62	1.125	PM-6206
207/306	2.78	3.06	1.125	PM-6207
208/307	3.09	3.38	1.125	PM-6208
209	3.28	3.56	1.558	PM-6209
210/308	3.47	3.75	1.558	PM-6210
211/309	3.85	4.13	1.558	PM-6211
212/310	4.22	4.50	1.558	PM-6212
213/311	4.60	4.88	1.558	PM-6213
214	4.85	5.13	1.558	PM-6214
215/312	5.03	5.32	1.558	PM-6215
216/313	5.47	5.75	1.930	PM-6216
217/314	5.85	6.13	1.930	PM-6217
218/315	6.22	6.50	1.930	PM-6218
219/316	6.64	6.92	1.930	PM-6219
220/317	6.97	7.25	2.062	PM-6220
221/318	7.47	7.75	2.062	PM-6221
222/319	7.82	8.10	2.062	PM-6222

LUBRIKO ELECTRIC MOTOR GREASE



- Grease Type: Sodium/Calcium
- NLGI Grade: 2
- Operating Temperature: 0°-225°F

A general purpose grease for ball and roller bearings in electric motors, pillow blocks and for plain bearings.

This popular lubricant has stood the test of time and remains one of the nation's most widely used general purpose lubricants. It has excellent shear stability and will pick up approximately 20% of its overall body weight in water and remain a workable lubricant.

CONTAINER SIZE	PART NUMBER
8 oz. Squeeze Tube	LBK-8
14-1/2 oz. Cartridge	LBK-14-1/2
1 Lb. Can	LBK-1
5 Lb. Can	LBK-5
10 Lb. Can	LBK-10
25 Lb. Can	LBK-25
35 Lb. Can	LBK-35

GE LONG LIFE GREASE

- Shell Alvania #2

Specifically recommended for General Electric ball and roller bearing motors and generators. High quality ingredients, no oil separation, protects against corrosion, excellent performance and stability.

CONTAINER SIZE	PART NUMBER
1 Lb. Can	LBK-DG6
5 Lb. Can	LBK-DG7
35 Lb. Pail	LBK-DG8

FLYWEIGHT ROTATING MECHANISM SPRINGS



RMS-N



RMS-O

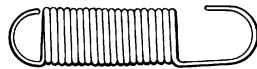

RMS-P



RMS-Q



RMS-R

MECH PART #	SPRING DIA.xLENGTHxCOLOR	PHOTO REF.	SPRING PART #
SCN-435-11	1/4"x1-7/8"xOR	RMS-N	SCN-395-11
SCN-435-17	7/32"x1-1/2"xBL	RMS-N	SCN-395-17
SCN-435-36	1/4"x1-5/16"xGR	RMS-N	SCN-395-36
SCN-435-36-17	1/4"x1-3/8"xYL	RMS-N	SCN-395-20
SCN-435-9	3/16"x 1-1/2"xRD	RMS-N	SCN-395-9
SCN-440-11	1/4"x1-7/8"xRD	RMS-N	SCN-499-11
SCN-440-17	1/4"x1-9/16"xSL	RMS-N	SCN-499-17
SCN-440-36	1/4"x1-1/2"xGY	RMS-N	SCN-499-36
SCN-444-11	1/4"x1-7/8"xRD	RMS-N	SCN-499-11
SCN-444-17	1/4"x1-1/2"xSL	RMS-N	SCN-499-17
SCN-444-36	1/4"x1-1/2"xGY	RMS-N	SCN-499-36
SCN-498-17	1/4"x1-9/16"xSL	RMS-N	SCN-499-17
SCN-498-36	1/4"x1-1/2"xGY	RMS-N	SCN-499-36

MECH PART #	SPRING DIA.xLENGTHxCOLOR	PHOTO REF.	SPRING PART #
SEM-409-36	13/64"x1-1/32"xDK GR	RMS-Q	SEM-373-36
SFK-3-11	9/32"x1-1/16"xBZ	RMS-O	SFK-5-17
SFK-3-17	9/32"x1-1/16"xBZ	RMS-O	SFK-5-17
SGE-1145-36	1/4"x7/8"xBR	RMS-Q	SGE-1179
SGE-1170-36	1/4"x7/8"xBR	RMS-Q	SGE-1179
SGE-22-17	21/64"x31/32"xBK	RMS-Q	SGE-268-17
SGE-573-12	21/64"x31/32"xSL	RMS-B	SGE-577-12
SGE-576-12	21/64"x31/32"xSL	RMS-Q	SGE-577-12
SGE-576-17	21/64"x1-3/16"xSL	RMS-Q	SGE-577-17
SGE-576-36	5/16"x1-1/6"xPL	RMS-Q	SGE-28-36
SGE-576-8	5/16"x7/8"xCOP	RMS-Q	SGE-577-17
SMR-2-11	1/4"x1-3/16"xCOP	RMS-Q	SMR-4-11
SMR-2-17	1/4"x1-3/16"xNAT	RMS-Q	SMR-4-17
SMR-2-36	1/4"x1-3/16"xDK RD	RMS-Q	SMR-4-36
SAW-21-17	15/64"x45/64"xSL	RMS-R	SAW-31-17
SAW-21-36	5/16"x55/64"xSL	RMS-R	SAW-31-36

NACHI, NTN AND KBC RADIAL BALL BEARINGS



Radial ball bearings use balls as the rolling element. This type of bearing creates a contact point between the inner and outer race. Radial ball bearings are designed to handle axial and radial loads. As the axial load increases, the contact angle becomes so great that the ball runs up on the edge of the groove. When high axial loads are encountered, it is best to use a ball bearing of angular contact design.

I.D.		O.D.		WIDTH		PART NUMBER ⁽¹⁾
MM	INCH	MM	INCH	MM	INCH	
3	0.118	10	0.394	4	0.157	623
4	0.157	13	0.512	5	0.197	624
4	0.157	16	0.630	5	0.197	634
4.76	0.188	12.70	0.500	4.98	0.196	RA3
5	0.197	14	0.551	5	0.197	605
5	0.197	16	0.630	5	0.197	625
5	0.197	19	0.748	6	0.236	635
6	0.236	17	0.669	6	0.236	606
6	0.236	19	0.748	6	0.236	626
6.35	0.250	15.88	0.625	4.98	0.196	R4
6.35	0.250	19.05	0.750	7.14	0.281	RA4
7	0.276	19	0.748	6	0.236	607
7	0.276	22	0.866	7	0.276	627
8	0.315	22	0.866	7	0.276	608
8	0.315	24	0.945	8	0.315	628
9	0.354	24	0.945	7	0.276	609
9	0.354	26	1.024	8	0.315	629
9.53	0.375	22.23	0.875	7.14	0.281	R6
10	0.394	26	1.024	8	0.315	6000
10	0.394	30	1.181	9	0.354	6200
10	0.394	35	1.378	11	0.433	6300
12	0.472	28	1.102	8	0.315	6001
12	0.472	32	1.260	10	0.394	6201
12	0.472	37	1.4567	12	0.472	6301
12.7	0.500	28.58	1.125	7.94	0.313	R8
12.7	0.500	32	1.260	10	0.394	6201-*/12.7
12.7	0.500	40	1.575	12	0.472	6203-*/12.7
13	0.512	32	1.260	10	0.394	6201-*/13
15	0.591	32	1.260	9	0.354	6002
15	0.591	35	1.378	11	0.433	6202
15	0.591	42	1.6535	13	0.512	6302
15.875	0.625	34.93	1.375	8.71	0.343	R10
15.875	0.625	35	1.378	11	0.433	6202-*/15.875
15.875	0.625	40	1.575	12	0.472	6203-*/15.875
16	0.630	35	1.378	11	0.433	6202-*/16
16	0.630	40	1.575	12	0.472	6203-*/16
17	0.669	35	1.378	10	0.394	6003
17	0.669	40	1.575	12	0.472	6203
17	0.669	47	1.8504	14	0.551	6303
19.05	0.750	40	1.575	12	0.472	6203-*/12
19.05	0.750	41.28	1.625	11.10	0.437	R12
20	0.787	42	1.654	12	0.472	6004
20	0.787	47	1.850	14	0.551	6204
20	0.787	52	2.0472	15	0.591	6304
20	0.787	52	2.047	15	0.591	BL304
22.23	0.875	47.63	1.875	12.70	0.500	R14
25	0.984	47	1.850	12	0.472	6005
25	0.984	52	2.047	15	0.591	6205
25	0.984	52	2.047	15	0.591	BL205
25	0.984	62	2.441	17	0.669	6305
25	0.984	62	2.441	17	0.669	BL305
25.40	1.000	50.80	2	12.70	0.500	R16
28.58	1.125	53.98	2.125	12.70	0.500	R18
30	1.181	55	2.165	13	0.512	6006
30	1.181	62	2.441	16	0.630	6206
30	1.181	62	2.441	16	0.630	BL206
30	1.181	72	2.835	19	0.748	6306

I.D.		O.D.		WIDTH		PART NUMBER ⁽¹⁾
MM	INCH	MM	INCH	MM	INCH	
30	1.181	72	2.835	19	0.748	BL306
31.75	1.250	57.15	2.25	12.70	0.500	R20
35	1.378	62	2.441	14	0.551	6007
35	1.378	72	2.835	17	0.669	6207
35	1.378	72	2.835	17	0.669	BL207
35	1.378	80	3.1496	21	0.827	6307
35	1.378	80	3.150	21	0.827	BL307
40	1.575	68	2.677	15	0.591	6008
40	1.575	80	3.150	18	0.709	6208
40	1.575	80	3.150	18	0.709	BL208
40	1.575	90	3.5433	23	0.906	6308
40	1.575	90	3.543	23	0.906	BL308
45	1.772	75	2.953	16	0.630	6009
45	1.772	85	3.346	19	0.748	6209
45	1.772	85	3.346	19	0.748	BL209
45	1.772	100	3.937	25	0.984	6309
45	1.772	100	3.937	25	0.984	BL309
50	1.969	80	3.150	16	0.630	6010
50	1.969	90	3.543	20	0.787	6210
50	1.969	90	3.543	20	0.787	BL210
50	1.969	110	4.3307	27	1.063	6310
50	1.969	110	4.331	27	1.063	BL310
55	2.165	90	3.543	18	0.709	6011
55	2.165	100	3.937	21	0.827	6211
55	2.165	100	3.937	21	0.827	BL211
55	2.165	120	4.7244	29	1.142	6311
55	2.165	120	4.724	29	1.142	BL311
60	2.362	95	3.740	18	0.709	6012
60	2.362	110	4.331	22	0.866	6212
60	2.362	110	4.331	22	0.866	BL212
60	2.362	130	5.1181	31	1.220	6312
60	2.362	130	5.118	31	1.220	BL312
65	2.559	100	3.937	18	0.709	6013
65	2.559	120	4.724	23	0.906	6213
65	2.559	120	4.724	23	0.906	BL213
65	2.559	140	5.5118	33	1.299	6313
65	2.559	140	5.512	33	1.299	BL313
70	2.756	110	4.331	20	0.787	6014
70	2.756	125	4.921	24	0.945	6214
70	2.756	125	4.921	24	0.945	BL214
70	2.756	150	5.9055	35	1.378	6314
70	2.756	150	5.906	35	1.378	BL314
75	2.953	115	4.528	20	0.787	6015
75	2.953	130	5.118	25	0.984	6215
75	2.953	160	6.2992	37	1.457	6315
75	2.953	160	6.299	37	1.457	BL315
80	3.150	125	4.921	22	0.866	6016
80	3.150	140	5.512	26	1.024	6216
80	3.150	140	5.512	26	1.024	BL216
80	3.150	170	6.6929	39	1.535	6316
80	3.150	170	6.693	39	1.535	BL316
85	3.346	130	5.118	22	0.866	6017
85	3.346	130	5.118	25	0.984	BL215
85	3.346	150	5.906	28	1.102	6217
85	3.346	150	5.906	28	1.102	BL217
85	3.346	180	7.0866	41	1.614	6317
85	3.346	180	7.087	41	1.614	BL317

⁽¹⁾To complete the part number add Prefix NA- = Nachi, NTN- = NTN, NB- = KBC.

Add Suffix -ZZ = Double Metal Shield, -LL = Double Rubber Seal, No suffix = Open Bearing.

NACHI, NTN AND KBC RADIAL BALL BEARINGS

NACHI **NTN**
KBC

I.D.		O.D.		WIDTH		PART NUMBER ⁽¹⁾
MM	INCH	MM	INCH	MM	INCH	
85	3.346	180	7.087	41	1.614	BL317
90	3.543	140	5.512	24	0.945	6018
90	3.543	160	6.299	30	1.181	6218
90	3.543	160	6.299	30	1.181	BL218
90	3.543	190	7.4803	43	1.693	6318
90	3.543	190	7.480	43	1.693	BL318
95	3.740	145	5.709	24	0.945	6019
95	3.740	170	6.693	32	1.260	6219
95	3.740	170	6.693	32	1.260	BL219
95	3.740	200	7.874	45	1.772	6319
95	3.740	200	7.874	45	1.772	BL319
100	3.937	150	5.906	24	0.945	6020
100	3.937	180	7.087	34	1.339	6220
100	3.937	180	7.087	34	1.339	BL220
100	3.937	215	8.4646	47	1.850	6320
100	3.937	215	8.465	47	1.850	BL320
105	4.134	160	6.299	26	1.024	6021
105	4.134	190	7.480	36	1.417	6221
105	4.134	190	7.480	36	1.417	BL221

I.D.		O.D.		WIDTH		PART NUMBER ⁽¹⁾
MM	INCH	MM	INCH	MM	INCH	
105	4.134	225	8.8583	49	1.929	6321
105	4.134	225	8.858	49	1.929	BL321
110	4.331	170	6.693	28	1.102	6022
110	4.331	200	7.874	38	1.496	6222
110	4.331	200	7.874	38	1.496	BL222
110	4.331	240	9.4488	50	1.969	6322
110	4.331	240	9.449	50	1.969	BL322
120	4.724	215	8.465	40	1.575	6224
120	4.724	260	10.236	55	2.165	6324
130	5.118	230	9.055	40	1.575	6226
130	5.118	280	11.024	58	2.283	6326
140	5.512	250	9.843	42	1.654	6228
140	5.512	300	11.811	62	2.441	6328
150	5.906	270	10.630	45	1.772	6230
150	5.906	320	12.598	65	2.559	6330
160	6.299	290	11.417	48	1.890	6232
160	6.299	340	13.386	68	2.677	6332
170	6.693	310	12.205	52	2.047	6234
170	6.693	360	14.173	72	2.835	6334

NACHI AND NTN DOUBLE ROW ANGULAR CONTACT BEARINGS

NACHI **NTN**

Double row of balls with angular contact points to provide additional axial capacity. Good for use when axial loads will be applied to the motor.

I.D.		O.D.		WIDTH		PART NUMBER ⁽¹⁾
MM	INCH	MM	INCH	MM	INCH	
10	0.394	30	1.181	14.3	0.563	5200
12	0.472	32	1.260	15.9	0.626	5201
15	0.591	35	1.378	15.9	0.626	5202
15	0.591	42	1.6535	19	0.748	5302
17	0.669	40	1.575	17.5	0.689	5203
17	0.669	47	1.8504	22.2	0.874	5303
20	0.787	47	1.850	20.6	0.811	5204
20	0.787	52	2.0472	22.2	0.874	5304
25	0.984	52	2.047	20.6	0.811	5205
25	0.984	62	2.441	25.4	1.000	5305
30	1.181	62	2.441	23.8	0.937	5206
30	1.181	72	2.835	30.2	1.189	5306
35	1.378	72	2.835	27	1.063	5207
35	1.378	80	3.1496	34.9	1.374	5307
40	1.575	80	3.150	30.2	1.189	5208
40	1.575	90	3.5433	36.5	1.437	5308
45	1.772	100	3.937	39.7	1.563	5309
45	1.772	85	3.346	30.2	1.189	5209

I.D.		O.D.		WIDTH		PART NUMBER ⁽¹⁾
MM	INCH	MM	INCH	MM	INCH	
50	1.969	90	3.543	30.2	1.189	5210
50	1.969	110	4.3307	44.4	1.748	5310
55	2.165	100	3.937	33.3	1.311	5211
55	2.165	120	4.7244	49.2	1.937	5311
60	2.362	110	4.331	36.5	1.437	5212
60	2.362	130	5.1181	54	2.126	5312
65	2.559	120	4.724	38.1	1.500	5213
65	2.559	140	5.5118	58.7	2.311	5313
70	2.756	125	4.921	39.7	1.563	5214
70	2.756	150	5.9055	63.5	2.500	5314
75	2.953	130	5.118	41.3	1.626	5215
75	2.953	160	6.2992	68.3	2.689	5315
80	3.150	140	5.512	44.4	1.748	5216
85	3.346	150	5.906	49.2	1.937	5217
90	3.543	160	6.299	52.4	2.063	5218
95	3.740	170	6.693	55.6	2.189	5219
100	3.937	180	7.087	60.3	2.374	5220

⁽¹⁾To complete the part number add Prefix NA- = Nachi, NTN- = NTN, NB- = KBC.
Add Suffix -ZZ = Double Metal Shield, -LL = Double Rubber Seal, No suffix = Open Bearing.

Angular contact bearings are ideally suited for use when high axial thrust loads are encountered. Typical applications include vertical hollow shaft pump motors. All bearings are flush ground for stacking multiple bearings in a motor.

I.D.		O.D.		WIDTH		PART NUMBER ⁽¹⁾
MM	INCH	MM	INCH	MM	INCH	
10	0.394	30	1.181	9	0.354	7200
12	0.472	32	1.260	10	0.394	7201
15	0.591	35	1.378	11	0.433	7202
17	0.669	40	1.575	12	0.472	7203
20	0.787	47	1.850	14	0.551	7204
25	0.984	52	2.047	15	0.591	7205
30	1.181	62	2.441	16	0.630	7206
35	1.378	72	2.835	17	0.669	7207
40	1.575	80	3.150	18	0.709	7208
45	1.772	85	3.346	19	0.748	7209
50	1.969	90	3.543	20	0.787	7210
55	2.165	100	3.937	21	0.827	7211
60	2.362	110	4.331	22	0.866	7212
65	2.559	120	4.724	23	0.906	7213
70	2.756	125	4.921	24	0.945	7214
75	2.953	130	5.118	25	0.984	7215
80	3.150	140	5.512	26	1.024	7216
85	3.346	150	5.906	28	1.102	7217
90	3.543	160	6.299	30	1.181	7218
95	3.740	170	6.693	32	1.260	7219
100	3.937	180	7.087	34	1.339	7220
105	4.134	190	7.480	36	1.417	7221
110	4.331	200	7.874	38	1.496	7222
120	4.724	215	8.465	40	1.575	7224
130	5.118	230	9.055	40	1.575	7226
140	5.512	250	9.843	42	1.654	7228
150	5.906	270	10.630	45	1.772	7230
160	6.299	290	11.417	48	1.890	7232
170	6.693	310	12.205	52	2.047	7234

I.D.		O.D.		WIDTH		PART NUMBER ⁽¹⁾
MM	INCH	MM	INCH	MM	INCH	
10	0.394	35	1.378	11	0.433	7300
12	0.472	37	1.457	12	0.472	7301
15	0.591	42	1.654	13	0.512	7302
17	0.669	47	1.85	14	0.551	7303
20	0.787	52	2.047	15	0.591	7304
25	0.984	62	2.441	17	0.669	7305
30	1.181	72	2.835	19	0.748	7306
35	1.378	80	3.15	21	0.827	7307
40	1.575	90	3.543	23	0.906	7308
45	1.772	100	3.937	25	0.984	7309
50	1.969	110	4.331	27	1.063	7310
55	2.165	120	4.724	29	1.142	7311
60	2.362	130	5.118	31	1.220	7312
65	2.559	140	5.512	33	1.299	7313
70	2.756	150	5.906	35	1.378	7314
75	2.953	160	6.299	37	1.457	7315
80	3.150	170	6.693	39	1.535	7316
85	3.346	180	7.087	41	1.614	7317
90	3.543	190	7.48	43	1.693	7318
95	3.740	200	7.874	45	1.772	7319
100	3.937	215	8.465	47	1.850	7320
105	4.134	225	8.858	49	1.929	7321
110	4.331	240	9.449	50	1.969	7322
120	4.724	260	10.236	55	2.165	7324
130	5.118	280	11.024	58	2.283	7326
140	5.512	300	11.811	62	2.441	7328
150	5.906	320	12.598	65	2.559	7330
160	6.299	340	13.386	68	2.677	7332
170	6.693	360	14.173	72	2.835	7334

⁽¹⁾To complete the part number add Prefix NTN-, and suffix -BL1G = Bronze cage flush ground, -BG = steel cage flush ground.

NTN AND NACHI - CARTRIDGE BEARINGS

This bearing consists of a single row of balls and is wider than the standard Conrad series bearing. These types of bearings are often found in gear boxes and older electric motors.

I.D.		O.D.		WIDTH		PART NUMBER ⁽¹⁾
MM	INCH	MM	INCH	MM	INCH	
20	0.787	47	1.850	20.6	0.811	63204
25	0.984	52	2.047	20.6	0.811	63205
30	1.181	62	2.441	23.8	0.937	63206
35	1.378	72	2.835	27	1.063	63207
40	1.575	80	3.150	30.2	1.189	63208
45	1.772	85	3.346	30.2	1.189	63209
50	1.969	90	3.543	30.2	1.189	63210
55	2.165	100	3.937	33.3	1.311	63211
60	2.362	110	4.331	36.5	1.437	63212
20	0.787	52	2.047	22.2	0.874	63304
25	0.984	62	2.441	25.4	1.000	63305
30	1.181	72	2.835	30.2	1.189	63306

I.D.		O.D.		WIDTH		PART NUMBER ⁽¹⁾
MM	INCH	MM	INCH	MM	INCH	
30	1.181	72	2.835	30.2	1.189	63306
35	1.378	80	3.15	34.9	1.374	63307
40	1.575	90	3.543	36.5	1.437	63308
45	1.772	100	3.937	39.7	1.563	63309
50	1.969	110	4.331	44.4	1.748	63310
55	2.165	120	4.724	49.2	1.937	63311
60	2.362	130	5.118	54	2.126	63312
65	2.559	140	5.512	58.7	2.311	63313
70	2.756	150	5.906	63.5	2.500	63314
75	2.953	160	6.299	68.3	2.689	63315
80	3.150	170	6.693	68.3	2.689	63316
85	3.346	180	7.087	73	2.874	63317
90	3.543	190	7.48	73	2.874	63318

Nachi cartridge bearings are only available in the 63200 series.

⁽¹⁾To complete the part number add Prefix NA- = Nachi, NTN- = NTN, NB- = KBC.
Add Suffix -ZZ = Double Metal Shield, -LL = Double Rubber Seal, No suffix = Open Bearing.

NACHI AND NTN - CYLINDRICAL ROLLER BEARINGS

NACHI
NTN

Cylindrical roller bearings are designed to handle heavy radial loads. Typical applications include HD belt drive and heavy overhung loads. N series has straight outer ring and two shoulders on inner ring with roller assembly. NJ series has two shoulders on outer ring with roller assembly and one shoulder on inner ring. NU series has two shoulders on outer ring with roller assembly and straight inner ring.

I.D.		O.D.		WIDTH		PART NUMBER ⁽¹⁾
MM	INCH	MM	INCH	MM	INCH	
20	0.787	47	1.850	14	0.551	N,NJ,NU204
20	0.787	52	2.047	15	0.591	N,NJ,NU304
25	0.984	52	2.047	15	0.591	N,NJ,NU205
25	0.984	62	2.441	17	0.669	N,NJ,NU305
30	1.181	62	2.441	16	0.630	N,NJ,NU206
30	1.181	72	2.835	19	0.748	N,NJ,NU306
35	1.378	72	2.835	17	0.669	N,NJ,NU207
35	1.378	80	3.15	21	0.827	N,NJ,NU307
40	1.575	80	3.150	18	0.709	N,NJ,NU208
40	1.575	90	3.543	23	0.906	N,NJ,NU308
45	1.772	85	3.346	19	0.748	N,NJ,NU209
45	1.772	100	3.937	25	0.984	N,NJ,NU309
50	1.969	90	3.543	20	0.787	N,NJ,NU210
50	1.969	110	4.331	27	1.063	N,NJ,NU310
55	2.165	100	3.937	21	0.827	N,NJ,NU211
55	2.165	120	4.724	29	1.142	N,NJ,NU311
60	2.362	110	4.331	22	0.866	N,NJ,NU212
60	2.362	130	5.118	31	1.220	N,NJ,NU312
65	2.559	120	4.724	23	0.906	N,NJ,NU213
65	2.559	140	5.512	33	1.299	N,NJ,NU313
70	2.756	125	4.921	24	0.945	N,NJ,NU214
70	2.756	150	5.906	35	1.378	N,NJ,NU314
75	2.953	130	5.118	25	0.984	N,NJ,NU215
75	2.953	160	6.299	37	1.457	N,NJ,NU315
80	3.150	140	5.512	26	1.024	N,NJ,NU216

I.D.		O.D.		WIDTH		PART NUMBER ⁽¹⁾
MM	INCH	MM	INCH	MM	INCH	
80	3.150	170	6.693	39	1.535	N,NJ,NU316
85	3.346	150	5.906	28	1.102	N,NJ,NU217
85	3.346	180	7.087	41	1.614	N,NJ,NU317
90	3.543	160	6.299	30	1.181	N,NJ,NU218
90	3.543	190	7.48	43	1.693	N,NJ,NU318
95	3.740	170	6.693	32	1.260	N,NJ,NU219
95	3.740	200	7.874	45	1.772	N,NJ,NU319
100	3.937	180	7.087	34	1.339	N,NJ,NU220
100	3.937	215	8.465	47	1.850	N,NJ,NU320
105	4.134	190	7.480	36	1.417	N,NJ,NU221
105	4.134	225	8.858	49	1.929	N,NJ,NU321
110	4.331	200	7.874	38	1.496	N,NJ,NU222
110	4.331	240	9.449	50	1.969	N,NJ,NU322
120	4.724	215	8.465	40	1.575	N,NJ,NU224
120	4.724	260	10.236	55	2.165	N,NJ,NU324
130	5.118	230	9.055	40	1.575	N,NJ,NU226
130	5.118	280	11.024	58	2.283	N,NJ,NU326
140	5.512	250	9.843	42	1.654	N,NJ,NU228
140	5.512	300	11.811	62	2.441	N,NJ,NU328
150	5.906	270	10.630	45	1.772	N,NJ,NU230
150	5.906	320	12.598	65	2.559	N,NJ,NU330
160	6.299	290	11.417	48	1.890	N,NJ,NU232
160	6.299	340	13.386	68	2.677	N,NJ,NU332
170	6.693	310	12.205	52	2.047	N,NJ,NU234
170	6.693	360	14.173	72	2.835	N,NJ,NU334

Prefix NTN- = NTN, NA- = Nachi, Suffix G1 or -Bronze = Bronze cage, -Steel = Steel cage.

NACHI - SPHERICAL ROLLER BEARINGS

NACHI

Spherical roller bearings can handle heavy axial and radial loads. The large contact area of the rollers allows these bearings to handle heavier loads than other bearings.

I.D.		O.D.		WIDTH		PART NUMBER ⁽¹⁾
MM	INCH	MM	INCH	MM	INCH	
40	1.575	80	3.150	23	0.906	22208
40	1.575	90	3.543	33	1.299	22308
45	1.772	85	3.346	23	0.906	22209
45	1.772	100	3.937	40	1.575	22309
50	1.969	90	3.543	23	0.906	22210
50	1.969	110	4.331	40	1.575	22310
55	2.165	100	3.937	25	0.984	22211
55	2.165	120	4.724	43	1.693	22311
60	2.362	110	4.331	28	1.102	22212
60	2.362	130	5.118	46	1.811	22312
65	2.559	120	4.724	31	1.220	22213
65	2.559	140	5.512	48	1.890	22313
70	2.756	125	4.921	31	1.220	22214
70	2.756	150	5.906	51	2.008	22314
75	2.953	130	5.118	31	1.220	22215
75	2.953	160	6.299	55	2.165	22315
80	3.150	140	5.512	33	1.299	22216
80	3.150	170	6.693	58	2.283	22316
85	3.346	150	5.906	36	1.417	22217
85	3.346	180	7.087	60	2.362	22317

I.D.		O.D.		WIDTH		PART NUMBER ⁽¹⁾
MM	INCH	MM	INCH	MM	INCH	
40	1.575	80	3.150	23	0.906	22208
40	1.575	90	3.543	33	1.299	22308
45	1.772	85	3.346	23	0.906	22209
45	1.772	100	3.937	40	1.575	22309
50	1.969	90	3.543	23	0.906	22210
50	1.969	110	4.331	40	1.575	22310
55	2.165	100	3.937	25	0.984	22211
55	2.165	120	4.724	43	1.693	22311
60	2.362	110	4.331	28	1.102	22212
60	2.362	130	5.118	46	1.811	22312
65	2.559	120	4.724	31	1.220	22213
65	2.559	140	5.512	48	1.890	22313
70	2.756	125	4.921	31	1.220	22214
70	2.756	150	5.906	51	2.008	22314
75	2.953	130	5.118	31	1.220	22215
75	2.953	160	6.299	55	2.165	22315
80	3.150	140	5.512	33	1.299	22216
80	3.150	170	6.693	58	2.283	22316
85	3.346	150	5.906	36	1.417	22217
85	3.346	180	7.087	60	2.362	22317

Prefix: NA- Suffix: EW33

ELECTRIC MOTOR SLEEVE BEARINGS

Progressive size sleeve bearing chart. Complete list of Wheeler Service bearings and OEM bearings. OEM bearings are noted by prefix EB or OEB. These bearings are steel shell with either bronze lining or babbitt lining. WS series bearings are made by Wheeler Group. Most Wheeler bearings are bronze construction unless noted otherwise. SS is steel shell. CI is cast iron shell. Bearings with -010 in the part number are .010" undersized to accommodate for worn shafts.

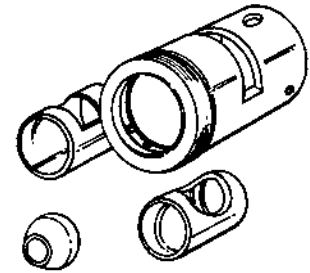

INSIDE DIA.(IN.)	OUTSIDE DIA.(IN.)	OVERALL LENGTH(IN.)	FLANGE O.D.(IN.)	FLANGE WIDTH(IN.)	MFR.	PART NUMBER
5/16	7/16	1/2	-	-	GE	WS-47-F
5/16	7/16	5/8	-	-	GE	WS-48-M-BZ
5/16	1/2	3/4	9/16	1/32	GE	WS-70-BZ
5/16	1/2	3/4	-	-	Peerless	WS-60-BZ
3/8	7/16	3/4	-	-	Wagner	WS-79-M
3/8	1/2	9/16	-	-	GE	WS-79-RT
3/8	9/16	3/4	5/8	1/16	GE	WS-93
3/8	9/16	13/16	-	-	GE	WS-100-BZ
3/8	9/16	1	-	-	Ohio	WS-130
3/8	9/16	1	-	-	R&M	WS-150
3/8	9/16	1-1/16	-	-	Emerson	WS-153
3/8	9/16	1-1/4	-	-	Emerson	WS-160
3/8	5/8	3/4	11/16	1/16	GE	WS-210
3/8	3/4	1	-	-	GE	WS-350
7/16	9/16	13/16	-	-	Emerson	WS-358-E-BZ
7/16	5/8	1-1/16	-	-	Emerson	WS-430-BZ
31/64	5/8	25/32	-	-	Century	EB-1471
31/64	5/8	1	-	-	Delco	EB-1241
1/2	19/32	47/64	-	-	Russell	WS-485-BZ
1/2	19/32	3/4	-	-	Delco	WS-486
1/2	19/32	3/4	-	-	Delco	WS-487
1/2	19/32	13/16	-	-	Delco	WS-489
1/2	19/32	15/16	-	-	Delco	WS-490
1/2	19/32	15/16	-	-	Delco	WS-490-010
1/2	5/8	13/32	-	-	GE	OEB-1453
1/2	5/8	29/64	-	-	GE	WS-492
1/2	5/8	5/8	-	-	Delco	WS-493
1/2	5/8	5/8	-	-	Emerson	WS-493-B
1/2	5/8	5/8	-	-	GE	WS-493-A
1/2	5/8	5/8	-	-	GE	OEB-1425
1/2	5/8	11/16	-	-	Marathon	WS-493-G-BZ
1/2	5/8	11/16	-	-	West.	WS-493-F
1/2	5/8	23/32	-	-	Master	WS-494
1/2	5/8	3/4	1	1/16	GE	WS-494-CH-BZ
1/2	5/8	3/4	-	-	GE	WS-494-010-B
1/2	5/8	3/4	-	-	GE	WS-494-B
1/2	5/8	3/4	-	-	GE	OEB-1360
1/2	5/8	3/4	-	-	West.	WS-494-C-BZ
1/2	5/8	25/32	-	-	Century	WS-494CM-BZ
1/2	5/8	13/16	-	-	B&G	WS-494-DG
1/2	5/8	13/16	-	-	Emerson	WS-494DF
1/2	5/8	13/16	-	-	Marathon	EB-1420
1/2	5/8	27/32	-	-	GE	WS-494-DM
1/2	5/8	7/8	-	-	Marathon	WS-494-H
1/2	5/8	15/16	-	-	GE	WS-498-B
1/2	5/8	15/16	-	-	J&H	WS-499-BZ
1/2	5/8	1	-	-	Diehl	WS-500-010-BZ
1/2	5/8	1	-	-	Diehl	WS-500-BZ
1/2	5/8	1	-	-	Emerson	WS-507
1/2	5/8	1	-	-	Sunlight	WS-510
1/2	5/8	1	-	-	Sunlight	WS-510-010
1/2	5/8	1	-	-	West.	WS-519
1/2	5/8	1	-	-	West.	WS-520-010
1/2	5/8	1	-	-	West.	WS-520
1/2	5/8	1-3/64	-	-	GE	WS-522
1/2	5/8	1-1/16	-	-	GE	WS-524-010
1/2	5/8	1-1/16	-	-	GE	WS-524
1/2	5/8	1-1/4	1	1/45	GE	WS-531-G-BZ
1/2	5/8	1-1/4	-	-	Emerson	WS-529
1/2	5/8	1-1/4	-	-	GE	WS-530
1/2	11/16	13/16	23/32	1/16	Century	WS-570
1/2	11/16	7/8	23/32	1/16	Century	WS-587-BZ

INSIDE DIA.(IN.)	OUTSIDE DIA.(IN.)	OVERALL LENGTH(IN.)	FLANGE O.D.(IN.)	FLANGE WIDTH(IN.)	MFR.	PART NUMBER
1/2	11/16	1	-	-	GE	WS-600-BZ
1/2	11/16	1	-	-	GE	WS-620
1/2	11/16	1-1/4	23/32	1/16	Century	WS-750
1/2	11/16	1-1/4	-	-	GE	WS-720-010-BZ
1/2	11/16	1-1/4	-	-	GE	WS-720
1/2	45/64	1-1/16	-	-	West.	WS-838
1/2	45/64	1-7/32	-	-	West.	WS-840
1/2	3/4	7/8	15/16	3/16	O'Matic	WS-906-BZ
1/2	3/4	1	-	-	R&M	WS-990
1/2	3/4	1	-	-	R&M	WS-1010
1/2	3/4	1	-	-	West.	WS-1020
1/2	3/4	1-1/32	-	-	Ohio	WS-1060
1/2	3/4	1-3/16	1	1/4	Ohio	WS-1180
1/2	3/4	1-3/16	-	-	GE	WS-1200-BZ
1/2	3/4	1-3/16	-	-	GE	WS-1200-010
1/2	3/4	1-1/4	-	-	GE	WS-1300
1/2	3/4	1-1/4	-	-	Ohio	WS-1270
17/32	21/32	5/8	-	-	Wagner	WS-1657-BZ
17/32	21/32	49/64	-	-	Wagner	WS-1658BZ
17/32	21/32	13/16	-	-	B&G	WS-1659-A
17/32	21/32	13/16	-	-	Wagner	WS-1659-BZ
17/32	21/32	1	-	-	Wagner	WS-1660
9/16	43/64	7/8	-	-	B&B	WS-1692-BZ
9/16	43/64	7/8	-	-	B&B	WS-1693-BZ
19/32	3/4	1-1/16	-	-	Marathon	EB-1376
39/64	3/4	1	-	-	B&G	EB-1382
5/8	3/4	11/16	-	-	Apex	WS-1814
5/8	3/4	3/4	-	-	Delco	WS-1815
5/8	3/4	3/4	-	-	West.	WS-1815-C
5/8	3/4	13/16	-	-	West.	WS-1815-G
5/8	3/4	53/64	-	-	GE	OEB-1361
5/8	3/4	27/32	-	-	GE	WS-1815-K-010-BZ
5/8	3/4	27/32	-	-	GE	WS-1815-K-BZ
5/8	3/4	7/8	-	-	B&B	WS-1817-BZ
5/8	3/4	7/8	-	-	West.	WS-1818-BZ
5/8	3/4	15/16	-	-	Delco	WS-1820-010
5/8	3/4	15/16	-	-	Delco	WS-1820
5/8	3/4	1	-	-	B&G	WS-1825-A-010-BZ
5/8	3/4	1	-	-	B&G	WS-1825-A-BZ
5/8	3/4	1	-	-	Bendix	EB-1248
5/8	3/4	1	-	-	Emerson	WS-1827-BZ
5/8	3/4	1	-	-	Sunlight	WS-1825
5/8	3/4	1	-	-	West.	WS-1826-BZ
5/8	3/4	1-1/16	-	-	GE	WS-1839-010
5/8	3/4	1-1/16	-	-	GE	WS-1839-BZ
5/8	3/4	1-1/16	-	-	West.	WS-1833-BZ
5/8	3/4	1-1/8	-	-	Delco	WS-1850
5/8	3/4	1-3/16	-	-	Delco	WS-1860
5/8	3/4	1-3/16	-	-	Emerson	WS-1863
5/8	3/4	1-1/4	-	-	GE	WS-1880-010
5/8	3/4	1-1/4	-	-	GE	WS-1880-BZ
5/8	3/4	1-1/4	-	-	GE	WS-1881-BZ
5/8	3/4	1-1/4	-	-	Marathon	WS-1885
5/8	3/4	1-9/32	-	-	Master	WS-1890
5/8	3/4	1-13/32	-	-	West.	WS-1902
5/8	3/4	1-13/32	-	-	West.	WS-1903-BZ
5/8	13/16	15/16	7/8	3/32	B&B	WS-1935
5/8	13/16	31/32	63/64	3/32	Delco	WS-1940
5/8	13/16	1	27/32	1/16	Century	WS-1960
5/8	13/16	1-3/32	15/16	1/16	Century	WS-1980
5/8	13/16	1-5/32	27/32	1/16	Century	WS-2000
5/8	13/16	2-7/32	27/32	1/16	Century	WS-1930-BZ
5/8	7/8	1	15/16	1/16	Day Fan	WS-2120-BZ

ELECTRIC MOTOR SLEEVE BEARINGS

INSIDE DIA. (IN.)	OUTSIDE DIA. (IN.)	OVERALL LENGTH (IN.)	FLANGE O.D. (IN.)	FLANGE WIDTH (IN.)	MFR.	PART NUMBER
5/8	7/8	1-1/4	-	-	Apex	WS-2160-BZ
5/8	7/8	1-1/4	-	-	West.	WS-2250
5/8	7/8	1-7/16	-	-	Day Fan	WS-2370
5/8	15/16	1-3/16	1-1/32	1/8	R&M	WS-2549
5/8	15/16	1-1/4	1-1/16	1/8	GE	WS-2570
21/32	51/64	51/64	-	-	Century	EB-1466
21/32	15/16	1-3/8	-	-	Leland	EB-1201
21/32	3/4	1-1/8	-	-	Leland	WS-3030
21/32	3/4	1-5/32	-	-	Leland	WS-3031
21/32	3/4	1-5/16	-	-	Leland	WS-3042-BZ
21/32	3/4	1-11/32	1-1/16	1/8	Leland	WS-3052
21/32	3/4	1-11/32	-	-	Leland	WS-3040
21/32	3/4	1-11/32	-	-	Leland	WS-3050-BZ
21/32	25/32	25/32	-	-	Wagner	WS-3055
21/32	25/32	1	-	-	Wagner	WS-3060-010
21/32	25/32	1	-	-	Wagner	WS-3060
21/32	25/32	1-1/16	-	-	J&H	WS-3065
21/32	25/32	1-1/8	-	-	Wagner	WS-3070-010
21/32	25/32	1-1/8	-	-	Wagner	WS-3070-BZ
21/32	25/32	1-9/32	-	-	Leland	WS-3071-BZ
21/32	25/32	1-5/16	7/8	11/32	Wagner	WS-3073-BZ
21/32	13/16	13/16	-	-	GE	OEB-1489
21/32	7/8	1-1/8	-	-	Wagner	WS-3090
43/64	51/64	13/16	-	-	GE	WS-3126-BZ
43/64	51/64	7/8	-	-	GE	WS-3127-010-BZ
43/64	51/64	7/8	-	-	GE	WS-3127-BZ
43/64	51/64	31/32	-	-	Century	WS-3128
43/64	51/64	1-1/16	-	-	Howell	WS-3130
43/64	13/16	1-1/8	-	-	Master	WS-3130-R
43/64	13/16	1-1/8	-	-	Master	WS-3131-BZ
11/16	13/16	1	-	-	Emerson	WS-3148-BZ
11/16	13/16	1-3/16	-	-	Emerson	WS-3158
11/16	13/16	1-5/16	-	-	Emerson	WS-3162
11/16	15/16	1	31/32	9/64	Century	WS-3172
11/16	15/16	1-1/8	31/32	3/32	Delco	WS-3180
11/16	15/16	1-1/4	31/32	9/64	Century	WS-3190
11/16	15/16	1-5/16	31/32	1/8	Century	WS-3210-BZ
11/16	15/16	1-31/64	31/32	9/64	Century	WS-3250
11/16	1	1-11/16	1-7/64	1/8	Sturtevant	WS-3340-BZ
11/16	1-1/8	11/16	-	-	B&G	EB-1384
11/16	1-1/8	2-1/4	C	S	Peerless	WS-3370
3/4	55/64	1-1/8	-	-	Delco	WS-3390
3/4	7/8	1	-	-	Wagner	WS-3393-BZ
3/4	7/8	1-3/32	-	-	Wagner	WS-3394-010-BZ
3/4	7/8	1-3/32	-	-	Wagner	WS-3394
3/4	7/8	1-3/16	-	-	Emerson	WS-3395-BZ
3/4	7/8	1-7/32	-	-	H/C	WS-3395-E-BZ
3/4	7/8	1-1/4	-	-	Leland	WS-3396
3/4	7/8	1-11/32	-	-	H/C	WS-3396-M-BZ
3/4	7/8	1-1/2	-	-	West.	WS-3397-010-BZ
3/4	7/8	1-1/2	-	-	West.	WS-3397-BZ
3/4	7/8	1-3/4	-	-	Peerless	WS-3397-L-BZ
3/4	57/64	1-1/4	-	-	Leland	WS-3397-P
3/4	15/16	1-1/2	-	-	GE	WS-3400-010-BZ
3/4	15/16	1-1/2	-	-	GE	WS-3400-BZ
3/4	1	1-3/32	1-1/16	3/32	H/C	WS-3406-BZ
3/4	1	1-3/32	1-1/16	3/32	H/C	WS-3407A-BZ
3/4	1	1-1/4	1-1/16	1/8	Peerless	WS-3409-D-BZ
3/4	1	1-1/2	1-1/16	5/32	West.	WS-3470-BZ
3/4	1	1-1/2	-	-	West.	WS-3440-BZ
3/4	1-1/16	1-3/32	1-3/32	-	Century	WS-3508
3/4	1-1/16	1-3/8	-	-	H/C	WS-3520-BZ
3/4	1-1/16	1-1/2	1-3/16	1/8	GE	WS-3530-BZ
3/4	1-1/16	1-3/4	-	-	Peerless	WS-3545
3/4	1-1/16	1-13/16	1-7/64	13/64	GE	WS-3570-BZ
3/4	1-1/16	1-7/8	1-3/16	1/8	GE	WS-3630-BZ
3/4	1-1/8	1-11/16	1-3/16	3/32	Emerson	WS-3730
3/4	1-1/8	1-3/4	C	S	Emerson	WS-3910-BZ
3/4	1-1/8	1-7/8	1-3/16"	1/8	A/C	WS-3740
3/4	1-1/8	1-7/8	1-3/16"	1/8	A/C	WS-3741
3/4	1-1/8	1-7/8	1-7/32"	1/8	GE	WS-3760-BZ
3/4	1-3/16	1-7/8	1-1/4"	5/16	GE	WS-3870
3/4	1-3/16	2	-	-	West.	WS-3890
3/4	1-1/4	1-1/2	-	-	Emerson	WS-3900-BZ
3/4	1-1/4	1-15/16	C	S	Kimble	WS-3920-BZ
3/4	1-5/8	1-3/4	-	-	Master	WS-4000
25/32	29/32	1-1/4	-	-	Howell	WS-4007-BZ
25/32	29/32	1-9/32	-	-	Leland	WS-4007-B-BZ

INSIDE DIA. (IN.)	OUTSIDE DIA. (IN.)	OVERALL LENGTH (IN.)	FLANGE O.D. (IN.)	FLANGE WIDTH (IN.)	MFR.	PART NUMBER
25/32	15/16	1-1/8	-	-	Leland	WS-4007C
25/32	15/16	1-11/32	-	-	Leland	WS-4007E
25/32	1	1-1/4	1-1/16	1/8	Howell	WS-4007J
13/16	15/16	1-9/32	-	-	Wagner	WS-4008-K-BZ
13/16	15/16	1-3/8	-	-	Emerson	WS-4008-M-BZ
13/16	15/16	1-1/2	-	-	Emerson	WS-4009-BZ
13/16	15/16	1-3/4	-	-	Master	WS-4018
13/16	15/16	1-3/4	-	-	Wagner	WS-4020-010
13/16	15/16	1-3/4	-	-	Wagner	WS-4020
13/16	61/64	1-1/4	-	-	B&B	WS-4024
13/16	31/32	1-1/4	-	-	Marathon	WS-4026-M-BZ
13/16	1-1/16	31/32	1-3/32	7/64	Century	WS-4030
13/16	1-1/16	1-1/4	-	-	Marathon	WS-4045-BZ
13/16	1-1/16	1-5/16	1-3/32	1/8	Century	WS-4059-BZ
13/16	1-1/16	1-29/64	1-3/32	7/64	Century	WS-4070-BZ
13/16	1-1/16	1-1/2	1-3/32	1/8	Century	WS-4080
13/16	1-1/16	1-9/16	-	-	Marathon	WS-4093-BZ
13/16	1-1/16	1-5/8	1-3/32	1/8	Century	WS-4110-BZ
13/16	1-1/16	1-3/4	1-1/8	1/8	Wagner	WS-4140
13/16	1-1/16	1-3/4	1-1/8	1/8	Wagner	WS-4140-010
13/16	1-1/16	2	1-1/8	1/8	Century	WS-4180
13/16	1-1/16	2-1/4	1-3/32	3/16	Century	WS-4240-BZ
13/16	1-19/32	1-3/4	B	S	Master	WS-4441
7/8	1	1-5/32	-	-	Delco	WS-4452-010-BZ
7/8	1	1-5/32	-	-	Delco	WS-4452
7/8	1	1-9/16	-	-	West.	WS-4453-BZ
7/8	1-1/16	7/8	1-1/8	1/16	Century	WS-4454-H-BZ
7/8	1-1/16	1	-	-	Ohio	WS-4454J-BZ
7/8	1-3/16	1-3/4	1-1/4	5/32	West.	WS-4520
7/8	1-3/16	2-1/16	1-3/8	5/32	West.	WS-4530
7/8	1-1/4	1-7/8	1-3/8	3/8	Kimble	WS-4570-BZ
7/8	1-5/16	1-3/4	-	-	A/C	WS-4663-BZ
7/8	1-5/16	2-3/16	-	-	A/C	WS-4665-L-BZ
7/8	1-1/2	2	-	-	Emerson	WS-4730
7/8	1-5/8	2-7/16	-	-	C/W	WS-4780-BZ
29/32	1-1/16	1	-	-	Leland	WS-4805-K
29/32	1-1/16	1-1/8	-	-	Leland	WS-4806-BZ
29/32	1-1/4	2	-	-	Leland	WS-4810
59/64	1-3/64	1-1/4	-	-	Wagner	WS-4814
15/16	1-1/16	1-1/4	-	-	B&G	EB-1481
15/16	1-1/16	1-57/64	-	-	Wagner	WS-4817
15/16	1-1/4	1-27/32	1-5/16	11/32	L/A	WS-4821-BZ
1	1-1/8	1-3/4	-	-	Peerless	WS-4891E-BZ
1	1-11/64	1-1/2	-	-	GE	WS-4892
1	1-1/4	1-5/16	1-11/32	3/16	L/A	WS-4895-BZ
1	1-1/4	1-9/16	1-5/16	1/8	GE	WS-4897
1	1-1/4	1-9/16	1-5/16	1/8	GE	WS-4897-SS
1	1-5/16	1-3/4	1-11/32	1/8	Century	WS-4919-BZ
1	1-5/16	2-1/2	1-23/64	3/8	GE	WS-4940
1	1-5/16	2-1/2	1-3/8	5/32	West.	WS-4970-BZ
1	1-3/8	2	1-1/2	1/8	GE	WS-4990
1	1-3/8	2-1/2	1-1/2	1/8	GE	WS-5020
1	1-3/8	2-1/2	1-1/2	1/8	GE	WS-5040
1	1-7/16	2-1/2	1-1/2	3/8	GE	WS-5180-BZ
1	1-7/16	2-1/2	1-9/16	1/8	A/C	WS-5190-BZ
1	1-7/16	2-1/2	1-9/16	7/16	A/C	WS-5210
1	1-7/16	2-33/64	1-9/16	11/64	West.	WS-5212-BZ
1-1/32	1-5/32	1-7/16	-	-	Delco	WS-5410
1-1/32	1-5/32	1-3/4	-	-	Delco	WS-5420-010-BZ
1-1/32	1-5/32	1-3/4	-	-	Delco	WS-5420-BZ
1-1/32	1-5/16	1-1/2	1-3/8	1/8	Delco	WS-5430
1-1/32	1-5/16	1-3/4	1-3/8	1/8	Delco	WS-5440
1-1/16	1-1/16	2	1-1/8	1/8	Century	WS-4190
1-1/16	1-3/16	1-13/16	-	-	Peerless	WS-5448
1-1/16	1-3/16	2-1/8	-	-	Wagner	WS-5450-BZ
1-1/16	1-3/16	2-1/4	-	-	Emerson	WS-5453
1-1/16	1-5/16	2-1/4	1-3/8	3/16	Century	WS-5459
1-1/16	1-3/8	2-1/2	1-1/2	1/4	Peerless	WS-5500-BZ
1-1/16	1-7/16	1-5/8	1-1/2	1/4	Century	WS-5520
1-1/16	1-7/16	2-5/8	1-15/32	1/4	Century	WS-5533-BZ
1-1/16	1-7/16	2-5/8	1-1/2	1/4	Century	WS-5530
1-1/16	1-7/16	2-5/8	1-1/2	1/4	Century	WS-5532-BZ
1-1/16	1-7/16	2-3/4	1-1/2	1/4	Century	WS-5540-BZ
1-1/16	1-1/2	2-7/16	1-19/32	3/8	Nwstrn. Elc.	WS-5580-BZ
1-1/16	1-7/8	2-7/8	-	-	C/W	WS-5690-BZ
1-3/32	1-7/32	1-1/2	-	-	B&G	WS-5692-C-BZ
1-1/8	1-1/4	1-3/4	-	-	West.	WS-5693

ELECTRIC MOTOR SLEEVE BEARINGS

INSIDE DIA. (IN.)	OUTSIDE DIA. (IN.)	OVERALL LENGTH (IN.)	FLANGE O.D. X WIDTH (IN.)	MFR.	PART NUMBER
3-1/2	5-1/8	9-7/16	-	West.	WS-9880-CI
3-1/2	5-1/2	6-5/16	6 X 17/32	GE	WS-9888-H-CI
3-1/2	5-7/8	9-1/4	6 X 1-3/4	A/C	WS-9891-CI
3-1/2	6-3/4	5-1/8	-	Siemens	WS-9891-JFX1-CI
3-5/8	4-3/4	9	4-15/16 X 25/32	Reliance	WS-9897-L-SS
3-5/8	4-3/4	9	4-15/16 X 13/16	Reliance	WS-9897-LX-SS
4	4-11/16	4-3/8	4-15/16 X 7/16	GE	WS-9925RA-SS
4	4-11/16	4-3/8	4-15/16 X 7/16	GE	WS-9925-RAX-SS
4	4-3/4	5-1/4	6-1/4 X 13/64	Siemens	WS-9925-REXF-BB
4	4-7/8	5-39/64	5-1/4 X 1/2	GE	WS-9926A-SS
4	4-7/8	5-39/64	5-1/4 X 1/2	GE	WS-9926-SS
4	4-7/8	6	5 X 1	GE	WS-9926-H-SS
4	4-7/8	6-7/32	5 X 15/32	GE	WS-9927-SS
4	4-7/8	10	5 X 1-1/2	GE	WS-9930-X-SS
4	4-7/8	10-3/4	5 X 1-1/2	GE	WS-9930-SS
4	4-29/32	4	5-1/4 X 13/32	West.	WS-9931-F-SS
4	4-29/32	4	5-1/4 X 13/32	West.	WS-9931-E-SS
4	5-5/8	4-3/8	5-7/8 X 3/8	West.	WS-9944-B-SS
4	5-5/8	4-3/8	5-7/8 X 3/8	West.	WS-9944-BX-SS
4	5-3/4	10-3/4	-	West.	WS-9950-CI
4	6-13/32	6-19/32	-	GE	WS-9965-G-CI
4	6-13/32	6-5/8	-	GE	WS-9965-G1-CI
4	6-1/2	5-1/4	-	Seimens	WS-9965-HX-CI
4	6-1/2	7-11/16	7-1/8 X 1-1/16	GE	WS-9965-K-CI
4	7-1/4	7-1/4	-	Seimens	WS-9965-T-CI
4	10-1/2	9-3/4	-	GE	WS-9966-KA-CI

INSIDE DIA. (IN.)	OUTSIDE DIA. (IN.)	OVERALL LENGTH (IN.)	FLANGE O.D. X WIDTH (IN.)	MFR.	PART NUMBER
4-3/16	2-5/16	3-7/8	-	Wagner	WS-8559-G
4-1/2	5-13/32	4-1/2	5-7/16 X 3/8	West.	WS-9968-TX-SS
4-1/2	5-13/32	4-1/2	5-49/64 X 3/8	West.	WS-9968-SX-SS
4-1/2	5-5/8	5-45/64	5-3/4 X 5/16	GE	WS-9969-H-SS
4-1/2	6-1/4	4-7/8	6-1/2 X 27/64	West.	WS-9972-H1-SS
4-1/2	6-1/4	4-7/8	6-1/2 X 27/64	West.	WS-9972-H1X-SS
4-1/2	7	6-13/32	7-13/32 X 17/64	GE	WS-9977-A-1-CI
4-1/2	7	6-13/32	7-13/32 X 13/32	GE	WS-9977-A-CI
4-1/2	7-1/4	9-7/16	8 X 1-1/16	GE	WS-9977-F-CI
4-1/2	8	6-13/32	8-13/32 X 13/32	GE	WS-9977-GJ-CI
4-1/2	8	6-13/32	8-13/32 X 13/32	GE	WS-9977-GJX-CI
5	5-3/4	5-1/4	-	Seimens	WS-9980-YZ-BB
5	6-1/8	7-1/2	6-1/2 X 1/2	West.	WS-9982-SS
5	6-1/8	7-3/4	6-1/4 X 3/4	GE	WS-9983-SS
5	6-3/4	5	7 X 7/16	West.	WS-9984-N1-SS
5	6-3/4	5	7 X 7/16	West.	WS-9984-N1X-SS
5	9	8	9-13/32 X 1	GE	WS-9990-DF1-CI
5	9	8	9-13/32 X 1	GE	WS-9990-DF-CI
5-1/2	8	6-13/32	8-13/32 X 17/64	GE	WS-9997-RI-CI
5-1/2	8	6-13/32	8-13/32 X 13/32	GE	WS-9997-R-CI
6-1/2	9-1/4	9-5/8	10 X 1-1/4	GE	WS-10075MXX-CI
6-1/2	9-1/2	8-1/4	9-7/8 X 1-1/4	GE	WS-10076-X-CI
6-1/2	9-1/2	8-1/4	9-29/32 X 1-1/4	GE	WS-10076-CI
7-1/2	10-1/4	8-1/4	10-21/32 X 1-1/4	GE	WS-10094-KX-CI
7-1/2	10-1/4	8-1/4	10-21/32 X 2-1/4	GE	WS-10094K-CI

Essex Brownell has access to numerous types and sources of bearings. If you cannot find the bearing you need in this chart please supply all the dimensions along with complete nameplate data and we will search to find the bearing required.

SELF ALIGNING SLEEVE BEARINGS

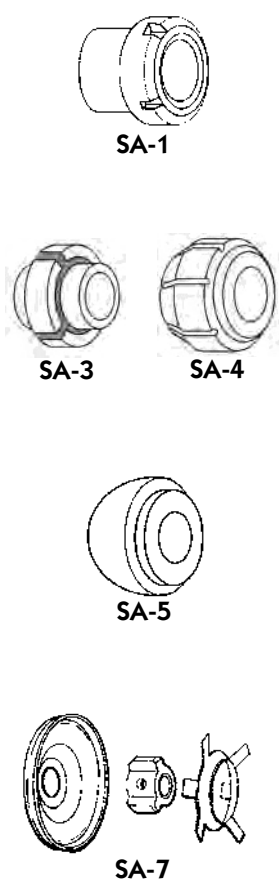

INSIDE DIA. (IN.)	OUTSIDE DIA. (IN.)	OVERALL LENGTH (IN.)	SPHERICAL DIA. (IN.)	PIPE DIA. (IN.)	MANUFACTURER	PHOTO REF.	PART NUMBER
9/64	5/16	5/16	5/16	0.2188		SA-11	SA-141-A1
5/32	11/32	3/8	3/8	0.2500		SA-11	SA-156-B5
3/16	0.380	0.291	.405	-		SA-10	SA-181-B22
3/16	15/32	13/32	1/2	-		SA-10	SA-187-A2A
1/4	0.554	1/2	9/16	0.4063		SA-11	SA-250-D7
1/4	0.554	5/8	9/16	0.4375		SA-11	SA-251-F1
1/4	9/16	9/16	19/32	0.3750		SA-11	SA-251-F7A
1/4	0.620	39/64	5/8	0.3750		SA-12	SA-251-E5
1/4	5/8	15/32	-	-	Universal	SA-5	EB-1464
1/4	5/8	9/16	5/8	0.3750		SA-11	SA-250-F15
1/4	3/4	1/2	3/4	0.6250		SA-13	SA-250-D19
1/4	51/64	1/2	-	-	Universal	SA-3	EB-1476
9/32	0.684	5/8	11/16	0.5625		SA-11	SA-281-H11A
5/16	9/16	5/8	9/16	0.4375		SA-11	SA-313-H2
5/16	9/16	1/2	5/8	-		SA-10	SA-312-J3C
5/16	19/32	7/16	5/8	-	Redmond	SA-10	EB-1235
5/16	5/8	15/32	-	-	Universal	-	EB-1434
5/16	3/4	1/2	-	-	Universal	SA-5	EB-1436
5/16	51/64	1/2	-	-	Universal	SA-3	EB-1475
3/8	0.622	3/8	0.622	-		SA-10	SA-376-K33
3/8	0.744	1	3/4	0.5000		SA-12	SA-376-L2
3/8	7/8	11/16	-	-	Fasco	SA-1	EB-1451
3/8	1	41/64	-	-	Universal	SA-4	EB-1445
27/64	13/16	5/8	7/8	-		SA-10	SA-422-K8
1/2	.800	33/64	13/16	-		SA-10	SA-502-L13
1/2	0.873	0.680	-	-		SA-13	SA-500-M15
1/2	7/8	11/16	-	-	Fasco	SA-1	EB-1450
1/2	0.890	3/4	29/32	0.6875		SA-11	EB-1387
1/2	-	-	-	-	RMR	SA-7	SWH-407
1/2	-	-	-	-	With Round Cover	SA-8	SWH-408
1/2	-	-	-	-	With Hex Cover	SA-9	EB-1490
1/2	-	-	-	-	Bearing Only	SA-11	SA-624-T10
5/8	1	1	1	0.8125			

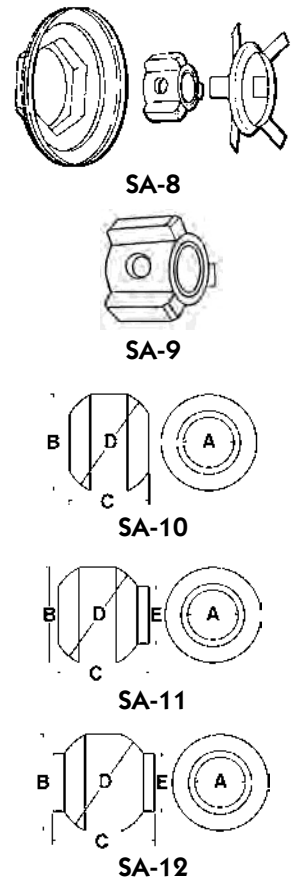

GENERAL PURPOSE BRONZE BUSHINGS

General purpose bronze bushings are available to grade SAE 660 Cast Bronze or Sintered Bronze (Oillite) that has lubrication impregnated into the bronze. Sintered bushings are available with or without flange.

I.D. (IN.)	O.D. (IN.)	LENGTH	SINTERED PART NUMBER	CAST BRONZE PART NUMBER
1/4	3/8	3/4	WS-0406-6	WC-0406-6
1/4	3/8	1	WS-0406-8	WC-0406-8
1/4	7/16	1	WS-0407-8	WC-0407-8
5/16	7/16	3/4	WS-0507-6	WC-0507-6
5/16	1/2	1	WS-0508-8	WC-0508-8
3/8	1/2	3/4	WS-0608-6	WC-0608-6
3/8	1/2	1	WS-0608-8	WC-0608-8
3/8	9/16	3/4	WS-0609-6	WC-0609-6
3/8	5/8	3/4	WS-0610-6	WC-0610-6
3/8	5/8	1	WS-0610-8	WC-0610-8
7/16	9/16	3/4	WS-0709-6	WC-0709-6
7/16	5/8	1-1/4	WS-0710-10	WC-0710-10
1/2	5/8	1	WS-0810-8	WC-0810-8
1/2	5/8	1-1/4	WS-0810-10	WC-0810-10
1/2	5/8	1-1/2	WS-0810-12	WC-0810-12
1/2	11/16	1-1/2	WS-0811-12	WC-0811-12
1/2	3/4	3/4	WS-0812-6	WC-0812-6
1/2	3/4	1	WS-0812-8	WC-0812-8
1/2	3/4	1-1/4	WS-0812-10	WC-0812-10
1/2	13/16	1-1/2	WS-0813-12	WC-0813-12
1/2	7/8	1-1/2	WS-0814-12	WC-0814-12
9/16	11/16	1-1/2	WS-0911-12	WC-0911-12
9/16	3/4	1-1/2	WS-0912-12	WC-0912-12
9/16	13/16	1-1/2	WS-0913-12	WC-0913-12
5/8	3/4	1	WS-1012-8	WC-1012-8
5/8	3/4	1-1/2	WS-1012-12	WC-1012-12
5/8	13/16	1-1/2	WS-1013-12	WC-1013-12
5/8	7/8	3/4	WS-1014-6	WC-1014-6
5/8	7/8	1-1/4	WS-1014-10	WC-1014-10
5/8	7/8	1-1/2	WS-1014-12	WC-1014-12
5/8	1	1	WS-1016-8	WC-1016-8
11/16	7/8	1-1/2	WS-1114-12	WC-1114-12
3/4	7/8	3/4	WS-1214-6	WC-1214-6
3/4	7/8	1	WS-1214-8	WC-1214-8
3/4	7/8	1-1/2	WS-1214-12	WC-1214-12
3/4	1	3/4	WS-1216-6	WC-1216-6
3/4	1	1	WS-1216-8	WC-1216-8
3/4	1	1-1/2	WS-1216-12	WC-1216-12
3/4	1-1/8	1-1/2	WS-1218-12	WC-1218-12
13/16	1	1-1/2	WS-1316-12	WC-1316-12
7/8	1	1	WS-1416-8	WC-1416-8
7/8	1	1-1/2	WS-1416-12	WC-1416-12
7/8	1-1/8	1	WS-1418-8	WC-1418-8
7/8	1-1/8	1-1/2	WS-1418-12	WC-1418-12
7/8	1-1/8	1-3/4	WS-1418-14	WC-1418-14
1	1-1/4	1-1/4	WS-1620-10	WC-1620-10
1	1-1/4	1-1/2	WS-1620-12	WC-1620-12
1	1-3/8	1	WS-1622-8	WC-1622-8
1	1-3/8	1-3/4	WS-1622-14	WC-1622-14
1-1/4	1-1/2	1-1/4	WS-2024-10	WC-2024-10
1-1/2	1-3/4	1-1/2	WS-2428-12	WC-2428-12
1-1/2	1-3/4	1-3/4	WS-2428-14	WC-2428-14

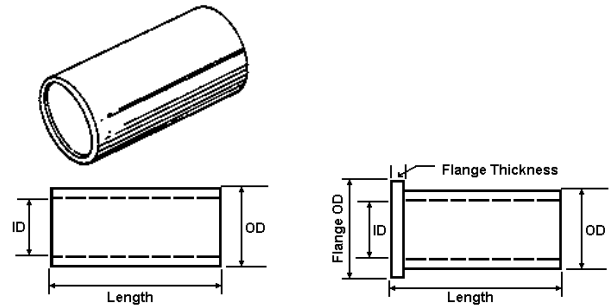

I.D. (IN.)	O.D. (IN.)	LENGTH	FLANGE O.D.(IN.) X THICK.	FLANGED PART NUMBER
1/4	3/8	1/4	1/2 X 1/16	WF-0406-2
1/4	3/8	3/8	1/2 X 1/16	WF-0406-3
1/4	3/8	3/4	1/2 X 1/16	WF-0406-6
5/16	7/16	3/8	9/16 X 1/16	WF-0507-3
5/16	7/16	3/4	9/16 X 1/16	WF-0507-6
3/8	1/2	1/2	11/16 X 1/16	WF-0608-4
3/8	1/2	3/4	11/16 X 1/16	WF-0608-6
3/8	1/2	1	11/16 X 1/16	WF-0608-8
3/8	9/16	3/4	11/16 X 1/16	WF-0609-6
3/8	5/8	3/4	7/8 X 1/16	WF-0610-6
3/8	5/8	3/4	7/8 X 1/16	WF-0610-6
3/8	5/8	1	7/8 X 1/16	WF-0610-8
7/16	9/16	3/4	11/16 X 1/16	WF-0709-6
7/16	5/8	1-1/4	7/8 X 1/8	WF-0710-10
1/2	5/8	1	7/8 X 1/8	WF-0810-8
1/2	5/8	1-1/4	7/8 X 1/8	WF-0810-10
1/2	5/8	1-1/2	7/8 X 1/8	WF-0810-12
1/2	3/4	3/4	1 X 1/8	WF-0812-6
1/2	3/4	1	1 X 1/8	WF-0812-8
1/2	3/4	1-1/4	1 X 1/8	WF-0812-10
5/8	3/4	1	1 X 1/8	WF-1012-8
5/8	13/16	1-1/2	1 X 1/8	WF-1013-12
5/8	7/8	3/4	1-1/8 X 1/8	WF-1014-6
5/8	7/8	1-1/4	1-1/8 X 1/8	WF-1014-10
5/8	1	1	1-1/4 X 3/16	WF-1016-8
3/4	7/8	3/4	1-1/8 X 1/8	WF-1214-6
3/4	1	3/4	1-1/4 X 3/16	WF-1216-6
3/4	1	1	1-1/4 X 3/16	WF-1216-8
3/4	1	1-1/2	1-1/4 X 3/16	WF-1216-12
7/8	1	1	1-1/4 X 3/16	WF-1416-8
7/8	1-1/8	1	1-1/2 X 3/16	WF-1418-8
7/8	1-1/8	1-1/2	1-1/2 X 3/16	WF-1418-12
7/8	1-1/8	1-3/4	1-1/2 X 3/16	WF-1418-14
1	1-1/4	1-1/4	1-1/2 X 3/16	WF-1620-10
1	1-1/4	1-1/2	1-1/2 X 3/16	WF-1620-12
1	1-3/8	1	1-5/8 X 3/16	WF-1622-8
1	1-3/8	1-3/4	1-5/8 X 3/16	WF-1622-14
1-1/4	1-1/2	1-1/4	1-3/4 X 3/16	WF-2024-10
1-1/2	1-3/4	1-1/2	2 X 3/16	WF-2428-12

Common sizes listed. Please provide dimensions if different size is required. Essex Brownel also carries Sintered and Cast bronze bar stock. Call for price and availability.

BEARING ACCESSORIES

BEARING SPRING WASHERS

Used to eliminate endplay in electric motors, and preload the bearings to reduce the possibility of bearing damage due to vibration and repetitive and non-repetitive runout.

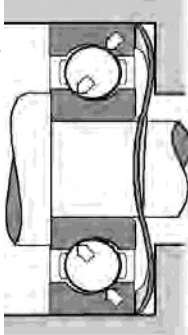

Wavy spring washers are supplied in three styles.

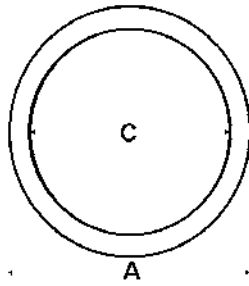

STYLE A

Stamped steel wavy spring washers, stamped from sheets of spring steel then formed to create wavy design. Spring rate is linear from 20% to 80% as spring washer is compressed. Made from high carbon steel.

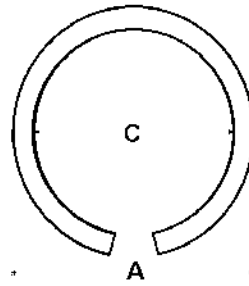

STYLE B

Split edge formed wavy spring washers. Produced from edge winding flat wire resulting in a circular grain design that reduces the chance of breakage common with stamped spring design. Split ring design produces a constant and even spring rate through-out deflection. Made from carbon steel.

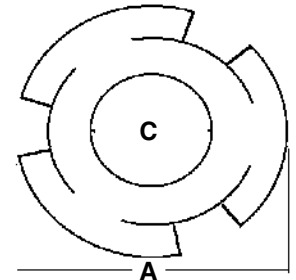

STYLE C

3 finger spring steel washers counteract noise, excess wear, endplay and vibration, especially at high speeds. They promote efficiency and smooth operation, reducing skidding wear on rotating parts. Made from high carbon steel.

BEARING O.D.--MM	BEARING SERIES	O.D. A (IN.)	I.D. C (IN.)	STYLE	PRELOAD IN LB.	PART #
10	R2	.367	.265	A	2 To 4	BSW-2
13	R2A,R3	.492	.350	A	3 To 5	BSW-3
16	634	.595	.312	C	3 To 1	BRW-1100
16	634,R4	.618	.440	A	3 To 5	BSW-4
19	635,636	.728	.344	C	4 To 8	BRW-1108
19	635,636,R4	.734	.531	A	4 To 7	BSW-5
22	627,608	.846	.453	C	3 To 7	BRW-1104
22	627,608,R6	.855	.650	A	4 To 7	BSW-6
24		.926	.453	C	6 To 10	BRW-1112
26	629,6000	1.004	.516	C	5 To 9	BRW-1116
30	6200	1.164	.688	C	9 To 13	BRW-1120
30	6200	1.181	1.048	B	19	BSW-30
32	6002,6201	1.24	.688	C	10 To 14	BRW-1124
32	6002,6201	1.26	1.127	B	20	BSW-32
35	6003,6202,6300	1.36	.814	C	11 To 15	BRW-1128
35	6003,6202,6300	1.378	1.245	B	22	BSW-35
37	6004,6301	1.457	1.314	B	23	BSW-37
40	6203	1.555	.971	C	15 To 21	BRW-1132
40	6203	1.555	1.00	C	31 To 39	BRW-1136
40	6203	1.575	1.432	B	25	BSW-40
42	6004,6302	1.654	1.511	B	26	BSW-42
47	6005,6204,6303	1.83	1.189	C	17 To 23	BRW-1140

BEARING O.D.--MM	BEARING SERIES	O.D. A (IN.)	I.D. C (IN.)	STYLE	PRELOAD IN LB.	PART #
47	6005,6204,6303	1.85	1.707	B	29	BSW-47
52	6205,6304	2.022	1.359	C	17 To 23	BRW-1144
52	6205,6304	2.047	1.897	B	32	BSW-52
62	6008,6206,6305	2.441	2.263	B	38	BSW-62
72	6207,6306	2.835	2.646	B	44	BSW-72
80	6010,6208,6307	3.15	2.961	B	49	BSW-80
85	6209	3.346	3.113	B	52	BSW-85
90	6011,6210,6308	3.543	3.31	B	56	BSW-90
100	6013,6211,6309	3.937	3.704	B	62	BSW-100
110	6014,6212,6310	4.331	4.098	B	68	BSW-110
120	6213,6311	4.724	4.491	B	74	BSW-120
125	6214	4.921	4.688	B	77	BSW-125
130	6017,6215,6312	5.118	4.885	B	80	BSW-130
140	6018,6216,6313	5.512	5.279	B	86	BSW-140
150	6217,6314	5.906	5.672	B	91	BSW-150
160	6218,6315	6.299	6.066	B	99	BSW-160
170	6219,6316	6.693	6.46	B	105	BSW-170
180	6220,6317	7.087	6.711	B	111	BSW-180
190	6221,6318	7.48	7.105	B	117	BSW-190
200	6222,6319	7.874	7.499	B	123	BSW-200
215	6224,6320	8.465	8.089	B	133	BSW-215

FIBER THRUST WASHERS

Made from hard vulcanized fibre. All washers are 1/32" thick. FW-1 through FW-26 sold in packages of 250, FW-27 through FW-37 sold in packages of 100.

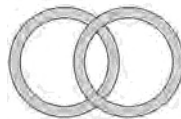

I.D. (IN.)	O.D. (IN.)	PART #	I.D. (IN.)	O.D. (IN.)	PART #
3/16	3/8	FW-1	3/4	1-1/16	FW-19
1/4	3/8	FW-2	13/16	1-1/8	FW-20
1/4	1/2	FW-3	7/8	1-3/16	FW-21
5/16	7/16	FW-4	15/16	1-1/4	FW-22
5/16	9/16	FW-5	1	1-1/4	FW-23
3/8	1/2	FW-6	1-1/32	1-5/16	FW-24
3/8	5/8	FW-7	1-1/16	1-3/8	FW-25
7/16	5/8	FW-8	1-1/8	1-9/32	FW-26
1/2	5/8	FW-9	1-3/16	1-9/16	FW-27
1/2	11/16	FW-10	1-1/4	1-5/8	FW-28
1/2	3/4	FW-11	1-5/16	113/16	FW-29
9/16	13/16	FW-12	1-3/8	1-7/8	FW-30
5/8	3/4	FW-13	1-1/2	2	FW-31
5/8	13/16	FW-14	1-5/8	2	FW-32
5/8	7/8	FW-15	1-3/4	2-1/4	FW-33
21/32	25/32	FW-16	1-7/8	2-3/8	FW-34
21/32	7/8	FW-17	2	2-1/2	FW-35
11/16	15/16	FW-18	2-1/4	2-3/4	FW-36

NYLON & STEEL

Spacer Washers

Nylon or steel washers, ideal for use as thrust or spacer washers on electric motors. Sold 100 per bag.

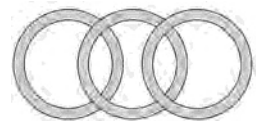

I.D. (IN.)	O.D. (IN.)	NYLON		STEEL .020 THICK PART #
		.020 THICK PART #	.030 THICK PART #	
1/4	3/8	TNW-1N	TNW-2N	
5/16	1/2	TNW-3N		
3/8	9/16		TNW-4N	
7/16	5/8		TNW-5N	
1/2	11/16	TNW-6N*	TNW-7N	MW-1
9/16	3/4	TNW-8N		
5/8	13/16	TNW-9N*	TNW-10N	
5/8	13/16		TNW-11N**	
21/32	27/32	TNW-12N	TNW-13N**	
11/16	7/8	TNW-14N		
11/16	15/16			MW-4
3/4	1		TNW-15N**	MW-5
13/16	1-1/16			MW-6
7/8	1-1/8		TNW-16N**	MW-7
1	1-1/4		TNW-17N**	
1	1-5/16			MW-8
1-1/16	1-5/16			MW-9

* .015" Thick

** .060 Thick

MOTOR REPAIR ACCESSORIES

EYEBOLTS

Forged from special, bar quality, fine grain, domestic carbon steel. Heat treated for strength and desired properties. Shoulder style eyebolts provide maximum capacity. Available in SAE & metric thread sizes.

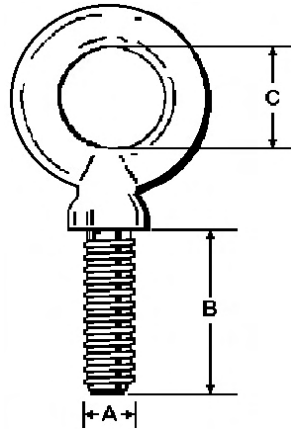

SAE		"B"		"C"		METRIC	
THREAD SIZE	PART NUMBER	SHANK LENGTH (IN.)	I. D. EYE (IN.)	THREAD SIZE	PART NUMBER	THREAD SIZE	PART NUMBER
DIA. X TPH (IN.)				DIA. X PITCH		DIA. X PITCH	
1/4 x 20	EYE-21	1	3/4	6mm X 1.0	EYE-21M	6mm X 1.0	EYE-21M
5/16 x 18	EYE-22	1-1/8	7/8	7mm X 1.0	EYE-22M	7mm X 1.0	EYE-22M
3/8 x 16	EYE-23	1-1/4	1	8mm X 1.25	EYE-23M	8mm X 1.25	EYE-23M
7/16 x 14	EYE-24	1-3/8	1-1/16	10mm X 1.5	EYE-24M	10mm X 1.5	EYE-24M
1/2 x 13	EYE-25	1-1/2	1-3/16	12mm X 1.7	EYE-25M	12mm X 1.7	EYE-25M
9/16 x 12	EYE-26	1-3/4	1-3/8	14mm X 2.0	EYE-26M	14mm X 2.0	EYE-26M
5/8 x 11	EYE-27	1-3/4	1-3/8	16mm X 2.0	EYE-27M	16mm X 2.0	EYE-27M
3/4 x 10	EYE-28	2	1-1/2	18mm X 2.5	EYE-28M	18mm X 2.5	EYE-28M
7/8 x 9	EYE-29	2-1/4	1-5/8	20mm X 2.5	EYE-29M	20mm X 2.5	EYE-29M
1 x 8	EYE-30	2-1/2	1-3/4	24mm X 3.0	EYE-30M	24mm X 3.0	EYE-30M
1-1/8 x 7	EYE-31	2-3/4	2	27mm X 3.0	EYE-31M	27mm X 3.0	EYE-31M
1-1/4 x 7	EYE-32	3	2-3/16	30mm X 3.5	EYE-32M	30mm X 3.5	EYE-32M
1-1/2 x 6	EYE-33	3-1/2	2-1/2	36mm X 4.0	EYE-33M	36mm X 4.0	EYE-33M

NAMEPLATE DRIVE SCREWS

Self threading drive screws hold nameplates in place. Simply drill the proper hole, and drive in place with a hammer.

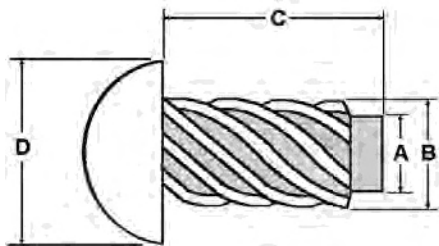

A	B	C	D	RECOMMENDED	
PILOT DIA.(IN.)	OVERALL DIA.(IN.)	LENGTH (IN.)	HEAD DIA.(IN.)	HOLE SIZE (IN.)/ DRILL NUMBER	PART NUMBER
1/16	5/64	3/16	1/8	.067/ 51	TD-51
3/32	7/64	3/16	13/64	.104/ 37	TD-37
7/64	9/64	1/4	1/4	.120/ 31	TD-31
1/8	5/32	5/16	9/32	.136/ 29	TD-29

MOTOR SHAFT FLINGERS

Inexpensive rubber flingers fit snug on the shaft of electric motors to prevent water from creeping up the shaft into the housing damaging bearings and other components of the motor.

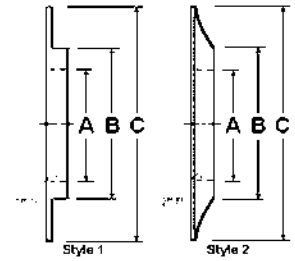

"A"	"B"	"C"	PHOTO	PART
INSIDE DIA. (IN.)	SHOULDER DIA. (IN.)	OUTSIDE DIA. (IN.)	REF.	NUMBER
1/2	1-1/4	2-1/4	1	TER-4
5/8	1-1/4	2-1/4	1	TER-5
3/4	1-1/4	2-1/4	1	TER-6
7/8	1-1/4	2	2	TER-7
1-1/8	1-1/2	2-7/16	2	TER-9
1-1/4	1-5/8	3	2	TER-11
1-5/8	2-1/8	3-3/16	2	TER-13
1-7/8	2-1/4	3-1/8	2	TER-15
2-1/8	2-1/2	3-1/4	2	TER-17
2-3/8	2-3/4	3-1/2	2	TER-19
2-7/8	3-3/8	4-1/8	2	TER-23
3-3/8	3-7/8	4-3/4	2	TER-27

CONNECTION NAMEPLATES

Aluminum nameplates showing standard connection diagrams for 3 phase dual voltage motors available in 9 lead delta or wye diagrams.

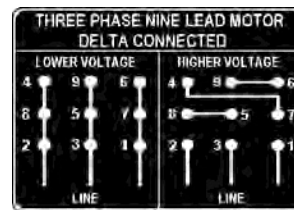

TD-10: 1-7/8" X 2-1/4"

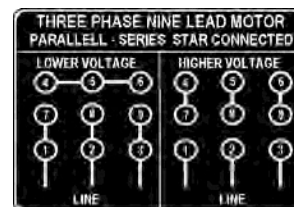

TD-12: 1-1/2" X 2-3/4"

REPLACEMENT MOTOR NAMEPLATES

Aluminum nameplates for use on all types of electric motors. Space provided for all necessary data, also suitable for use on generators and transformers.

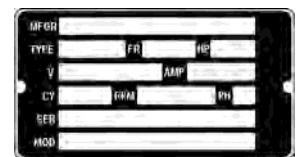

TD-14: 1-9/16" X 2-11/16"

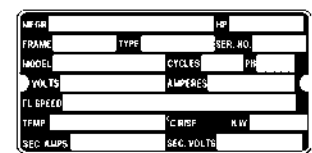

TD-16: 1-15/32" X 3-31/32"

MOTOR REPAIR ACCESSORIES

SILICONE RUBBER SPACE HEATERS

Silicone rubber space heaters help prevent condensation in electric motors, mounted to the stator shell under each end turn. Use silicone rubber adhesive to secure the heater to the stator shell. All heaters are made of .055" thick flexible silicone rubber with fiberglass reinforcement. Leads are 24" long silicone rubber. Maximum operating temperature is 475°F.

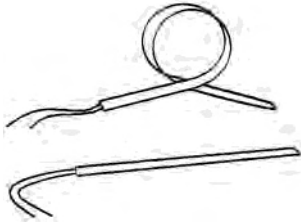

WIDTH (IN.)	LENGTH (IN.)	WATTAGE	VOLTAGE	SUGGESTED FRAME SIZE	PART NUMBER
1	6	30	120	140-180	TFH-03012
1	6	30	240	140-180	TFH-03024
1	12	60	120	210-250	TFH-06012
1	12	60	240	210-250	TFH-06024
1	24	120	120	280-360	TFH-12012
1	24	120	240	280-360	TFH-12024
2	24	240	120	400-440	TFH-24012
2	24	240	240	400-440	TFH-24024

STEEL TERMINAL BOXES

- Economical
- Universal design - fits most electric motors.
- Sizes to fit 140 to 500 series motor frames

These terminal boxes are manufactured with 16 gauge, deep-drawn, cold rolled steel. Each terminal box is costed with an oil film to prevent rusting.

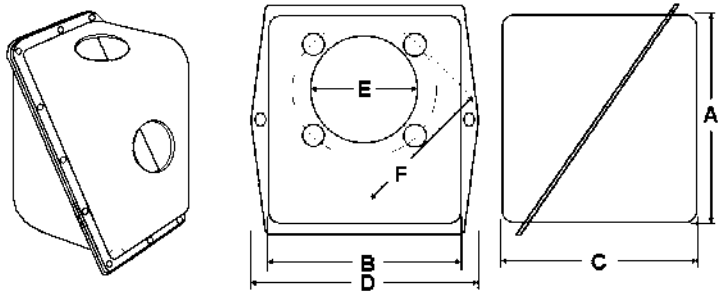

CUBIC INCHES	BOX DIMENSIONS			FLANGE WIDTH D (IN.)	COLD ROLLED STEEL MOTOR ENTRY		CONDUIT OPENING (IN.)	FRAME SIZES	PART NUMBER
	HEIGHT A (IN.)	WIDTH B (IN.)	DEPTH C (IN.)		MOUNTING BOLT CIRCLE DIA. F (IN.)	MOTOR ENTRY OPENING E (IN.)			
30	5-3/16	3	2-1/2	4-1/2	2-1/4	1-5/8	3/4 & 1	140T - 215T	MTB-1
50	4-3/4	3-7/8	3-1/16	5-1/2	3-1/8	2-3/8	1-11/16	254T - 256T	MTB-2
190	8	5-1/8	5	7	4	2-1/2	2-1/2	284T - 365T	MTB-3
500	12	6	7	7-3/4	None	2-1/2	3	404T - 445T	MTB-4

CAST TERMINAL BOXES

- Available in heavy cast iron or aluminum
- All conduit openings are standard pipe threads
- Sizes to fit 5 HP to 500 HP

When corrosion factors are too tough for steel terminal boxes, cast Iron or aluminum is the answer. Each terminal box comes complete with gaskets on all machined surfaces.

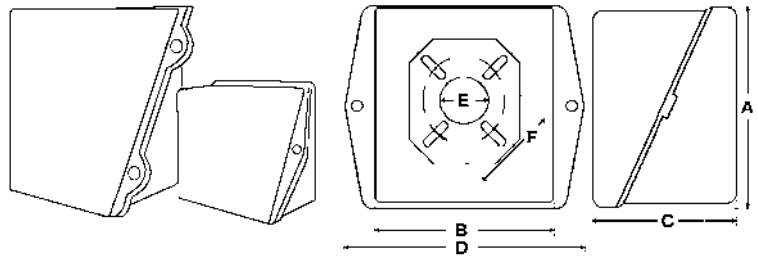

CUBIC INCHES	BOX DIMENSIONS			FLANGE WIDTH D (IN.)	MOTOR ENTRY OPENING E (IN.)	MOUNTING BOLT CIRCLE DIA. F (IN.)	CONDUIT OPENING (IN.)	FRAME SIZES	CAST	
	HEIGHT A (IN.)	WIDTH B (IN.)	DEPTH C (IN.)						IRON PART NUMBER	ALUMINUM PART NUMBER
81	6	5-1/8	4	6-7/8	1-3/4	2-1/4 - 3-3/8	1 NPT	184T - 286T	TBI-1	TBA-1
242	9-3/4	6-1/4	5-5/8	8-1/4	2-1/4	2-3/4 - 5	2 NPT	286T - 365T	TBI-2	TBA-2
657	12-1/4	9	7-3/4	11-1/4	2-3/4	3-1/4 - 8	2-1/2 NPT	365T - 445T	TBI-3	TBA-3
995	14-3/4	10-5/8	8-1/2	13-1/4	3-1/2	5 - 10	3 NPT	445T & Larger	TBI-4	TBA-4

GASKETS FOR STEEL TERMINAL BOXES

All gaskets are made from 1/32" thick vellumoid, resistant to oil, grease, gasoline and water.

TERMINAL BOX	GASKET BETWEEN BASE AND MOTOR	COVER GASKET
MTB-1	RG-1	CG-1
MTB-2	RG-2	CG-2
MTB-3	RG-3	CG-3

VANGUARD START CAPACITORS

- Temperature range -40°C to 65°C
- Suitable for 50 or 60 Cycle
- Plastic case requires no insulation
- 2-1/4" spade terminals per post
- Made in USA



125 VOLT		
MFD.	CASE SIZE (IN.)	PART NUMBER
21-25	1-7/16 X 2-3/4	BC-21
25-30	1-7/16 X 2-3/4	BC-25
30-36	1-7/16 X 2-3/4	BC-30
36-43	1-7/16 X 2-3/4	BC-36
43-53	1-7/16 X 2-3/4	BC-43
53-64	1-7/16 X 2-3/4	BC-56
64-77	1-7/16 X 2-3/4	BC-64
72-88	1-7/16 X 2-3/4	BC-75
88-108	1-7/16 X 2-3/4	BC-86
108-130	1-7/16 X 2-3/4	BC-108
124-149	1-7/16 X 2-3/4	BC-124
130-156	1-7/16 X 2-3/4	BC-130
145-175	1-7/16 X 2-3/4	BC-145
161-193	1-7/16 X 2-3/4	BC-161
189-227	1-7/16 X 2-3/4	BC-189
200-240	1-7/16 X 2-3/4	BC-200
216-259	1-7/16 X 2-3/4	BC-216
243-292	1-7/16 X 2-3/4	BC-243
270-324	1-7/16 X 2-3/4	BC-270
300-360	1-7/16 X 2-3/4	BC-300
324-388	1-7/16 X 2-3/4	BC-324
324-388	1-13/16 X 3-3/8	BC-324-S
334-401	1-7/16 X 2-3/4	SLF-6
340-408	1-13/16 X 3-3/8	BC-340
378-440	1-13/16 X 3-3/8	BC-378
400-480	1-13/16 X 3-3/8	BC-400
437-525	1-7/16 X 3-3/8	SLF-7
460-552	1-13/16 X 3-3/8	BC-460
540-648	1-13/16 X 4-3/8	BC-540
540-648	1-13/16 X 3-3/8	BC-540-S
590-708	1-13/16 X 4-3/8	BC-590
590-708	1-13/16 X 3-3/8	BC-590-S
708-849	2-1/16 X 4-3/8	BC-705
710-852	1-13/16 X 3-3/8	BC-705-S
829-994	2-1/16 X 4-3/8	BC-800
815-975	1-13/16 X 4-3/8	BC-815
1000-1200	2-1/16 X 4-3/8	BC-1000

165 VOLT		
MFD.	CASE SIZE (IN.)	PART NUMBER
108-130	1-7/16 X 3-3/8	BC-108M-165
124-149	1-7/16 X 3-3/8	BC-124M-165
145-175	1-7/16 X 3-3/8	BC-145M-165
161-193	1-13/16 X 3-3/8	BC-161M-165
189-227	1-13/16 X 3-3/8	BC-189M-165
233-280	1-13/16 X 3-3/8	BC-233M-165
243-292	1-13/16 X 3-3/8	BC-243M-165
270-324	1-13/16 X 3-3/8	BC-270M-165
340-408	1-13/16 X 4-3/8	BC-340M-165
378-453	1-13/16 X 4-3/8	BC-378M-165
400-480	1-13/16 X 4-3/8	BC-400M-165
710-852	2-1/16 X 4-3/8	BC-710M-165
815-970	2-1/16 X 4-3/8	BC-815M-165
1020-1264	2-1/16 X 4-3/8	BC-1020M-165

250 VOLT		
MFD.	CASE SIZE (IN.)	PART NUMBER
21-25	1-7/16 X 2-3/4	BC-21M-250
25-30	1-7/16 X 2-3/4	BC-25M-250
30-36	1-7/16 X 2-3/4	BC-30M-250
36-43	1-7/16 X 3-3/8	BC-36M-250
36-43	1-7/16 X 2-3/4	BC-36M-250-S
43-53	1-7/16 X 3-3/8	BC-43M-250
47-56	1-7/16 X 3-3/8	BC-47M-250
53-64	1-7/16 X 3-3/8	BC-53M-250
64-77	1-13/16 X 3-3/8	BC-64M-250
72-88	1-13/16 X 3-3/8	BC-72M-250
88-108	1-13/16 X 3-3/8	BC-88M-250
108-130	1-13/16 X 3-3/8	BC-108M-250
124-149	1-13/16 X 3-3/8	BC-124M-250
130-156	1-13/16 X 3-3/8	BC-130M-250
145-175	2-1/16 X 3-3/8	BC-145M-250
161-193	1-13/16 X 4-3/8	BC-161M-250
189-227	2-1/16 X 4-3/8	BC-189M-250
216-259	2-1/16 X 4-3/8	BC-216M-250
233-280	2-1/16 X 4-3/8	BC-233M-250
270-324	2-1/16 X 4-3/8	BC-280M-250
340-408	2-1/16 X 4-3/8	BC-340M-250
400-480	2-9/16 X 4-3/8	BC-400M-250

330 VOLT		
MFD.	CASE SIZE (IN.)	PART NUMBER
21-25	1-13/16 X 3-3/8	BC-21M-330
25-30	1-13/16 X 3-3/8	BC-25M-330
30-36	1-13/16 X 3-3/8	BC-30M-330
36-43	1-13/16 X 3-3/8	BC-36M-330
43-53	1-13/16 X 3-3/8	BC-43M-330
53-64	1-13/16 X 3-3/8	BC-54M-330
64-77	1-13/16 X 3-3/8	BC-64M-330
72-88	1-13/16 X 4-3/8	BC-72M-330
88-108	2-1/16 X 3-3/8	BC-88M-330
88-108	1-13/16 X 4-3/8	BC-88M-330-S
108-130	2-1/16 X 4-3/8	BC-108M-330
124-149	2-1/16 X 4-3/8	BC-124M-330
130-156	2-1/16 X 4-3/8	BC-130M-330
145-174	2-9/16 X 4-3/8	BC-145M-330
161-193	2-9/16 X 4-3/8	BC-161M-330
189-226	2-9/16 X 4-3/8	BC-189M-330
216-259	2-9/16 X 4-3/8	BC-216M-330
270-324	2-9/16 X 4-3/8	BC-270M-330

125 VOLT MIDGET CASE		
MFD.	CASE SIZE (IN.)	PART NUMBER
108-130	1-1/8 X 2-5/8	MC-108S
124-149	1-1/8 X 2-5/8	MC-124S
145-175	1-1/8 X 2-5/8	MC-145S
161-193	1-1/8 X 2-5/8	MC-161S
194-216	1-3/8 X 2-1/2	MC-194S
216-259	1-3/8 X 2-1/2	MC-216S

RECESSED CASE			
MFD.	VOLTAGE	CASE SIZE (IN.)	PART NUMBER
159-191	125	2-1/16 X 4-3/8	BC-159-REC
250-300	125	2-1/16 X 4-3/8	BC-250-REC
43-52	250	2-1/16 X 4-3/8	BC-43M-250-REC
59-71	250	2-1/16 X 4-3/8	BC-59M-250-REC
86-103	250	2-1/16 X 4-3/8	BC-86M-250-REC
105-126	250	2-1/16 X 4-3/8	BC-105M-250-REC

These capacitors have a 1-3/8" recess to hold overload on submersible pump control panels.

GENERAL ELECTRIC RUN CAPACITORS

GE's Gem III capacitors are manufactured with high-grade metallized polypropylene film. This film is in the range of 6 to 10 microns thick, depending on the application voltage and conditions. The metallized electrode is several hundred angstroms thick.

The film is wound into capacitor rolls on high-speed, high-precision machines.

The winding is extremely tight so that there is not enough space between the layers for corona (localized partial electrical discharges) to occur. The rolls are sprayed on both ends with metal to make connection to the extremely thin edges of the metallized electrodes. This process is critical to the quality and performance of the capacitors.

The rolls are assembled into metal cases, GE's proprietary Dielektril VI liquid is introduced under vacuum, and the capacitors are sealed. They are then subjected to 100% electrical testing for capacitance, dissipation factor, and high potential electrical withstand, both terminal-to-terminal.

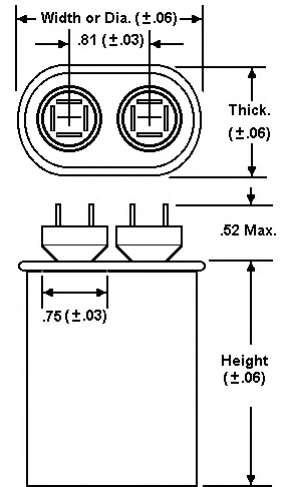

ROUND CASE

MFD.	370 VOLT CASE SIZE (IN.)	PART NUMBER
5	1-3/4 X 2-7/8	RD-5-370
7.5	1-3/4 X 2-7/8	RD-7.5-370
10	1-3/4 X 2-7/8	RD-10-370
15	1-3/4 X 2-7/8	RD-15-370
17.5	1-3/4 X 2-7/8	RD-17.5-370
20	1-3/4 X 2-7/8	RD-20-370
22.5	1-3/4 X 2-7/8	RD-22.5-370
25	1-3/4 X 2-7/8	RD-25-370
30	1-3/4 X 2-7/8	5VR0303
30	1-3/4 X 3-7/8	RD-30-370
35	1-3/4 X 3-7/8	RD-35-370
40	1-3/4 X 3-7/8	RD-40-370
45	2 X 3-7/8	RD-45-370
50	2 X 3-7/8	RD-50-370
60	2-1/2 X 3-7/8	RD-60-370

MFD.	440 VOLT CASE SIZE (IN.)	PART NUMBER
10	1-3/4 X 2-7/8	RD-10-440
12.5	1-3/4 X 2-7/8	RD-12.5-440
15	1-3/4 X 2-7/8	RD-15-440
17.5	1-3/4 X 2-7/8	RD-17.5-440
20	1-3/4 X 3-7/8	RD-20-440
25	1-3/4 X 3-7/8	RD-25-440
30	2 X 3-7/8	RD-30-440
35	2 X 3-7/8	RD-35-440
40	2 X 3-7/8	RD-40-440
45	2-1/2 X 3-7/8	RD-45-440
50	2-1/2 X 3-7/8	RD-50-440
55	2-1/2 X 4-3/4	RD-55-440
60	2-1/2 X 4-3/4	RD-60-440
70	2-1/2 X 4-3/4	RD-70-440
75	2-1/2 X 5-1/4	RD-75-440

OVAL CASE

MFD.	370 VOLT CASE SIZE (IN.)	PART NUMBER
2	1-5/16 X 2-5/32 X 2-1/8	OV-2-370
3	1-5/16 X 2-5/32 X 2-1/8	OV-3-370
4	1-5/16 X 2-5/32 X 2-1/8	OV-4-370
5	1-5/16 X 2-5/32 X 2-1/8	OV-5-370
6	1-5/16 X 2-5/32 X 2-1/8	OV-6-370
7.5	1-5/16 X 2-5/32 X 2-7/8	OV-7.5-370
10	1-5/16 X 2-5/32 X 2-7/8	OV-10-370
12.5	1-5/16 X 2-5/32 X 3-7/8	OV-12.5-370
15	1-29/32 X 2-29/32 X 2-1/8	OV-15-370
17.5	1-29/32 X 2-29/32 X 2-7/8	OV-17.5-370
20	1-29/32 X 2-29/32 X 2-7/8	OV-20-370
25	1-29/32 X 2-29/32 X 2-7/8	OV-25-370
30	1-29/32 X 2-29/32 X 2-7/8	OV-30-370
35	1-29/32 X 2-29/32 X 3-7/8	OV-35-370
40	1-29/32 X 2-29/32 X 3-7/8	OV-40-370
45	1-29/32 X 2-29/32 X 5-3/4	OV-45-370
50	1-29/32 X 2-29/32 X 5-3/4	OV-50-370
55	1-31/32 X 3-21/32 X 3-7/8	OV-55-370
60	1-31/32 X 3-21/32 X 3-7/8	OV-60-370

MFD.	440 VOLT CASE SIZE (IN.)	PART NUMBER
2	1-5/16 X 2-5/32 X 2-1/8	OV-2-440
3	1-5/16 X 2-5/32 X 2-1/8	OV-3-440
4	1-5/16 X 2-5/32 X 2-7/8	OV-4-440
5	1-5/16 X 2-5/32 X 2-7/8	OV-5-440
6	1-5/16 X 2-5/32 X 2-7/8	OV-6-440
7.5	1-5/16 X 2-5/32 X 3-7/8	OV-7.5-440
10	1-5/16 X 2-5/32 X 3-7/8	OV-10-440
12.5	1-29/32 X 2-29/32 X 3-7/8	OV-12.5-440
15	1-29/32 X 2-29/32 X 2-7/8	OV-15-440
17.5	1-29/32 X 2-29/32 X 2-7/8	OV-17.5-440
20	1-29/32 X 2-29/32 X 2-7/8	OV-20-440
25	1-29/32 X 2-29/32 X 2-7/8	OV-25-440
30	1-29/32 X 2-29/32 X 3-7/8	OV-30-440
35	1-29/32 X 2-29/32 X 3-7/8	OV-35-440
40	1-29/32 X 2-29/32 X 3-7/8	OV-40-440
45	1-29/32 X 2-29/32 X 4-3/4	OV-45-440
50	1-31/32 X 3-21/32 X 3-7/8	OV-50-440
55	1-31/32 X 3-21/32 X 4-3/4	OV-55-440
60	1-31/32 X 3-21/32 X 4-1/4	OV-60-440
75	1-31/32 X 3-21/32 X 5-1/2	OV-75-440

GENERAL ELECTRIC RUN CAPACITORS

DUAL RATED ROUND CASE

MFD.	370 VOLT CASE SIZE (IN.)	PART NUMBER
15/10	2 X 2-7/8	RD-15/10-370
15/4	2 X 2-7/8	RD-15/4-370
15/5	2 X 2-7/8	RD-15/5-370
15/7.5	2 X 2-7/8	RD-15/7.5-370
20/10	2 X 2-7/8	RD-20/10-370
20/4	2 X 2-7/8	RD-20/4-370
20/5	2 X 2-7/8	RD-20/5-370
20/7.5	2 X 2-7/8	RD-20/7.5-370
25/10	2 X 3-7/8	RD-25/10-370
25/4	2 X 2-7/8	RD-25/4-370
25/5	2 X 2-7/8	RD-25/5-370
25/7.5	2 X 2-7/8	RD-25/7.5-370
30/10	2 X 3-7/8	RD-30/10-370
30/4	2 X 3-7/8	RD-30/4-370
30/5	2 X 3-7/8	RD-30/5-370
30/7.5	2 X 3-7/8	RD-30/7.5-370
35/10	2 X 3-7/8	RD-35/10-370
35/4	2 X 3-7/8	RD-35/4-370
35/5	2 X 3-7/8	RD-35/5-370
35/7.5	2 X 3-7/8	RD-35/7.5-370
40/10	2 X 3-7/8	RD-40/10-370
40/4	2 X 3-7/8	RD-40/4-370
40/5	2 X 3-7/8	RD-40/5-370
40/7.5	2 X 3-7/8	RD-40/7.5-370
45/10	2 X 4-3/4	RD-45/10-370
45/4	2 X 4-3/4	RD-45/4-370
45/5	2 X 4-3/4	RD-45/5-370
45/7.5	2 X 4-3/4	RD-45/7.5-370
50/10	2 X 4-3/4	RD-50/10-370
50/5	2 X 4-3/4	RD-50/5-370
50/7.5	2 X 4-3/4	RD-50/7.5-370
55/10	2-1/2 X 3-7/8	RD-55/10-370
55/5	2-1/2 X 3-7/8	RD-55/5-370
55/7.5	2-1/2 X 3-7/8	RD-55/7.5-370

MFD.	440 VOLT CASE SIZE (IN.)	PART NUMBER
15/4	2 X 2-7/8	RD-15/4-440
15/5	2 X 2-7/8	RD-15/5-440
15/7.5	2 X 3-7/8	RD-15/7.5-440
20/4	2 X 2-7/8	RD-20/4-440
20/5	2 X 2-7/8	RD-20/5-440
20/7.5	2 X 3-7/8	RD-20/7.5-440
25/10	2 X 3-7/8	RD-25/10-440
25/4	2 X 3-7/8	RD-25/4-440
25/5	2 X 3-7/8	RD-25/5-440
25/7.5	2 X 3-7/8	RD-25/7.5-440
30/10	2 X 3-7/8	RD-30/10-440
30/4	2 X 3-7/8	RD-30/4-440
30/5	2 X 3-7/8	RD-30/5-440
30/7.5	2 X 3-7/8	RD-30/7.5-440
35/4	2 X 4-3/4	RD-35/4-440
35/5	2 X 4-3/4	RD-35/5-440
35/7.5	2 X 4-3/4	RD-35/7.5-440
35/10	2 X 4-3/4	RD-35/10-440
40/4	2 X 4-3/4	RD-40/4-440
40/5	2 X 4-3/4	RD-40/5-440
40/7.5	2 X 4-3/4	RD-40/7.5-440
40/10	2 X 4-3/4	RD-40/10-440
45/4	2 X 4-3/4	RD-45/4-440
45/5	2-1/2 X 3-7/8	RD-45/5-440
45/7.5	2-1/2 X 3-7/8	RD-45/7.5-440
50/10	2-1/2 X 4-3/4	RD-50/10-440
50/5	2-1/2 X 4-3/4	RD-50/5-440
50/7.5	2-1/2 X 4-3/4	RD-50/7.5-440
55/10	2-1/2 X 4-3/4	RD-55/10-440
55/5	2-1/2 X 4-3/4	RD-55/5-440
55/7.5	2-1/2 X 4-3/4	RD-55/7.5-440
60/10	2-1/2 X 4-3/4	RD-60/10-440
60/5	2-1/2 X 4-3/4	RD-60/5-440
60/7.5	2-1/2 X 4-3/4	RD-60/7.5-440

DUAL RATED OVAL CASE

MFD.	370 VOLT CASE SIZE (IN.)	PART NUMBER
17.5/5	1-29/32 X 2-29/32 X 2-7/8	OV-17.5/5-370
15/10	1-29/32 X 2-29/32 X 2-7/8	OV-15/10-370
15/3	1-29/32 X 2-29/32 X 2-7/8	OV-15/3-370
15/4	1-29/32 X 2-29/32 X 2-7/8	OV-15/4-370
15/5	1-29/32 X 2-29/32 X 2-7/8	OV-15/5-370
17.5/4	1-29/32 X 2-29/32 X 2-7/8	OV-17.5/4-370
20/10	1-29/32 X 2-29/32 X 3-7/8	OV-20/10-370
20/15	1-29/32 X 2-29/32 X 3-7/8	OV-20/15-370
20/3	1-29/32 X 2-29/32 X 2-7/8	OV-20/3-370
20/4	1-29/32 X 2-29/32 X 2-7/8	OV-20/4-370
20/5	1-29/32 X 2-29/32 X 2-7/8	OV-20/5-370
25/10	1-29/32 X 2-29/32 X 2-7/8	OV-25/10-370
25/4	1-29/32 X 2-29/32 X 2-7/8	OV-25/4-370
25/5	1-29/32 X 2-29/32 X 2-7/8	OV-25/5-370
25/6	1-29/32 X 2-29/32 X 2-7/8	OV-25/6-370
30/4	1-29/32 X 2-29/32 X 3-7/8	OV-30/4-370
30/5	1-29/32 X 2-29/32 X 3-7/8	OV-30/5-370
30/7.5	1-29/32 X 2-29/32 X 3-7/8	OV-30/7.5-370
35/3	1-29/32 X 2-29/32 X 3-7/8	OV-35/3-370
35/4	1-29/32 X 2-29/32 X 4-1/4	OV-35/4-370
35/5	1-29/32 X 2-29/32 X 3-7/8	OV-35/5-370
40/5	1-29/32 X 2-29/32 X 3-7/8	OV-40/5-370

MFD.	440 VOLT CASE SIZE (IN.)	PART NUMBER
5/4	1-29/32 X 2-29/32 X 2-1/8	OV-5/4-440
10/5	1-29/32 X 2-29/32 X 2-7/8	OV-10/5-440
15/5	1-29/32 X 2-29/32 X 2-7/8	OV-15/5-440
17.5/5	1-29/32 X 2-29/32 X 3-7/8	OV-17.5/5-440
17.5/7.5	1-29/32 X 2-29/32 X 3-7/8	OV-17.5/7.5-440
20/15	1-31/32 X 2-21/32 X 2-7/8	OV-20/15-440
20/5	1-29/32 X 2-29/32 X 3-1/2	OV-20/5-440
25/10	1-31/32 X 2-21/32 X 2-7/8	OV-25/10-440
25/5	1-29/32 X 2-29/32 X 3-7/8	OV-25/5-440
30/4	1-29/32 X 2-29/32 X 3-7/8	OV-30/4-440
30/5	1-31/32 X 2-21/32 X 2-7/8	OV-30/5-440
35/5	1-29/32 X 2-29/32 X 4-3/4	OV-35/5-440
35/7.5	1-29/32 X 2-29/32 X 4-3/4	OV-35/7.5-440
40/5	1-31/32 X 3-21/32 X 3-7/8	OV-40/5-440
40/7.5	1-29/32 X 2-29/32 X 4-3/4	OV-40/7.5-440
45/5	1-29/32 X 2-29/32 X 4-3/4	OV-45/5-440

All the run capacitors listed in this section contain a pressure sensitive interrupter. 1/2" minimum clearance must be allowed between the terminal and the case at the end of the capacitor.

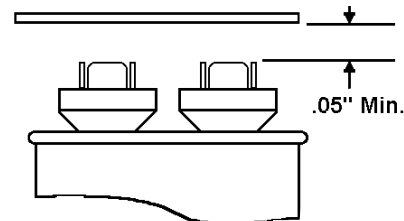

GENERAL ELECTRIC RUN CAPACITORS

BULK PACKED HVAC CAPACITORS

Buy in bulk and save big \$\$.

MFD.	CASE SIZE (IN.)	QTY / CASE	PART NUMBER
5	1-5/16 X 2-5/32 X 2-1/8	48	BP-OV-5-370
7.5	1-5/16 X 2-5/32 X 2-1/8	48	BP-OV-7.5-370
10	1-5/16 X 2-5/32 X 2-1/8	48	BP-OV-10-370



660 VOLT RUN CAPACITORS

Ideally suited for phase converter applications

MFD.	THICK X WIDTH X LENGTH (IN.)	PART NUMBER
2	1-5/16 X 2-1/16 X 2-11/16	5VC0026
3	1-5/16 X 2-1/16 X 2-11/16	5VC0036
4	1-5/16 X 2-1/16 X 3-3/16	5VC0046
5	1-5/16 X 2-1/16 X 3-5/16	5VC0056
6	1-5/16 X 2-1/16 X 3-5/16	5VC0066
8	1-29/32 X 2-29/32 X 3-5/16	5VC0086
10	1-29/32 X 2-29/32 X 3-5/16	5VC0106
12	1-29/32 X 2-29/32 X 4-5/16	5VC0126
15	1-29/32 X 2-29/32 X 4-5/16	5VC0156
18	1-31/32 X 3-21/32 X 4-5/16	5VC0186
20	1-31/32 X 3-21/32 X 4-5/16	5VC0206
22	1-31/32 X 3-21/32 X 4-5/16	5VC0226

DRY RUN CAPACITORS

These capacitors use a plastic housing like a start capacitor. Usually size is smaller, and voltage ratings are usually 240 volt.

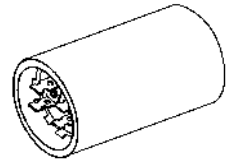

MFD.	VOLTAGE	DIA. X LENGTH (IN.)	PART NUMBER
8	240	1-7/16 X 3-3/8	SBG-8-240
16	240	1-3/4 X 3-1/2 (Metal)	SLS-6
22.5	330	1-13/16 X 3-3/8	SBG-22.5-330
30	240	1-13/16 X 3-3/8	SBG-30-240
40	240	1-13/16 X 3-3/8	SBG-40-240

START CAPACITOR ACCESSORIES

END CAPS

Use these end caps in conjunction with the snap-in mounting brackets to provide a secure means of mounting start capacitors.

Lead Down style provides an opening at the bottom of the capacitor Lead Up style provides an opening on the top for leads.



CAP DIAMETER (IN.)	LEAD DOWN PART NUMBER	LEAD UP PART NUMBER
1-7/16	BCH-1	BCH-25
1-13/16	BCH-2	BCH-26
2-1/16	BCH-3	BCH-27
2-9/16	BCH-15	BCH-28

SNAP-IN MOUNTING BRACKETS

Used in conjunction with the end caps. Provides a secure method of mounting start capacitors.



CAPACITOR LENGTH (IN.)	PART NUMBER
2-3/4	BCH-16
3-3/8	BCH-4
4-3/8	BCH-5

BLEEDER RESISTOR

15,000 ohm, 2 watt bleeder resistor helps prolong switch contact life by discharging capacitor to reduce arcing.



PART NUMBER	PART NUMBER
RAC-RG-3	RAC-RG-3

RUN CAPACITOR ACCESSORIES

MOUNTING BRACKETS

Strap metal bracket is designed to wrap around capacitor to provide a sure method of mounting capacitor in terminal boxes and panels.

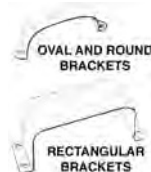

OVAL CASE BRACKETS	
CAP SIZE (IN.)	PART NUMBER
1-5/16 X 2-5/32	RAC-1516
1-29/32 X 2-29/32	RAC-200
1-31/32 X 3-213/32	RAC-131
ROUND CASE BRACKETS	
CAP SIZE (IN.)	PART NUMBER
1-5/8 Diameter	RAC-135
1-3/4 Diameter	RAC-134
2 Diameter	RAC-201
2-1/2 Diameter	RAC-250

TERMINAL BOOTS

Rubber boot with lead hole. Boot covers entire terminal post on run capacitors.



# OF TERMINAL POST	# OF LEAD HOLES	PART NUMBER
2	1	RAC-RG-1
2	2	RAC-RG-2
3	3	RAC-RG-5

POTENTIAL MOTOR START RELAYS

Replaces GE Type 3ARR1, 3ARR3, RBM Type 91255 & 128 Series.

Potential motor start relays sense the induced voltage in the start winding. As a single phase motor comes up to rated speed, the start winding will react much like a transformer, and the voltage potential across the start winding will be higher than applied voltage. Typical induced voltages found in single phase motors are approximately 165% of applied voltage. Potential voltage relays have a set of normally closed contacts which are opened when the induced voltage reaches the minimum/maximum pick up voltage range of the relay. General purpose replacement relays are available in several voltage ranges to compensate for design variations found in electric motors. Two styles of relays are available, RBM Series and Leland Faraday Series. The electrical characteristics are the same for each type of relay. Primary differences are physical dimensions. Both styles are supplied with a universal mounting plate that have ears for mounting in almost any application, unused ears can be broken off if not needed. Operates on 50/60 cycle.

RBM SERIES

The beauty of this relay is inside, large double break contact can handle the amperage for the higher horsepower applications. Good replacement for obsolete stationary switches and relays. Ideal for phase converter applications. Overall Dimensions: 2-3/8" x 1-7/8" x 1-7/8".



LELAND FARADAY SERIES

Good replacement when customer is looking for exact physical size of GE relay. Single contacts are adequate for handling moderate to low amperages. Good replacement for obsolete stationary switches and relays. Overall dimensions: 2" x 1-7/8" x 1-7/8"

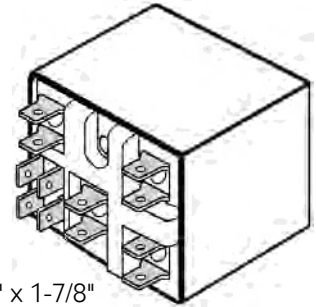

ELECTRICAL SPECIFICATIONS:

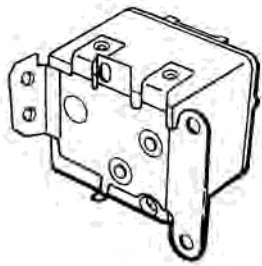

RELAY SERIES	CONTINUOUS COIL VOLTAGE	PICK UP MIN.	VOLTAGE MAX.	DROP OUT MAX.	RBM SERIES	LF SERIES
63	170	140	153	65	RBM-90-63	LF90630
64	395	245	275	140	RBM-90-64	LF90640
65	336	171	184	90	RBM-90-65	LF90650
66	395	208	239	130	RBM-90-66	LF90660
67	420	300	328	121	RBM-90-67	LF90670
68	495	323	352	135	RBM-90-68	LF90680
69	395	180	195	100	RBM-90-69	
70	256	278	306	115	RBM-90-70	
71	420	223	252	150	RBM-90-71	LF90710

COMPETITORS CROSS REFERENCE:

RELAY SERIES	STEVECO	MARS	MARS-II	MARS MODEL	W W GRAINGER	RELAY & CONTROL	OLD TEMCUSEH	NEW TECUMSEH	RBM SERIES	LF SERIES
63	90-63	19002	19163	MARS-63	6X549	1063	82777	82963	RBM-90-63	LF90630
64	90-64	19003	19164	MARS-64	6X554/6X555	1064	82782/82783	83964	RBM-90-64	LF90640
65	90-65	19004	19165	MARS-65	6X550/6X560	1065	82778	82965	RBM-90-65	LF90650
66	90-66	19005	19166	MARS-66	6X553	1066	82781	82966/82971	RBM-90-66	LF90660
67	90-67	19006	19167	MARS-67	6X557	1067	82785	82967	RBM-90-67	LF90670
68	90-68	19007	19168	MARS-68	6X559	1068	82787	82968	RBM-90-68	LF90680
69		19008	19169	MARS-69	6X551	1069	-	-	RBM-90-69	
70		19009	19170	MARS-70	-	1070	-	-	RBM-90-70	
71	90-71	19010	19171	MARS-71	6X553	1071	82781	82966/82971	RBM-90-71	LF90710

WIRING DIAGRAMS

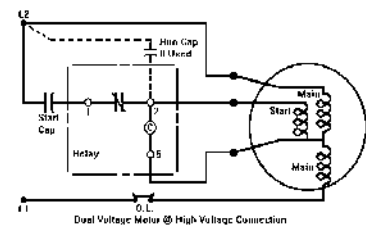
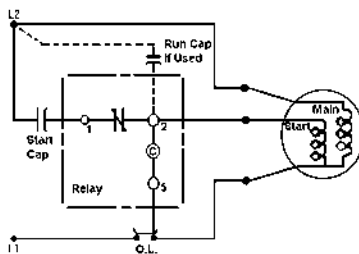
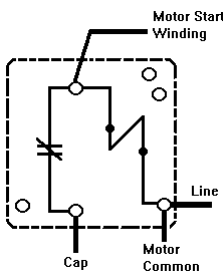

TEXAS INSTRUMENTS CURRENT TYPE RELAYS

The Klixon SL-10A current type relay is a compact, high capacity relay designed for universal application in split-phase and capacitor start single phase motors with start winding currents up to 25 amps. SL-10A series relays sense the high inrush current in the run winding during start condition. The normally open contacts close as the current in the run winding rises during start. When the current drops as the motor comes up to speed, the contacts open again dropping the start winding out of the circuit. The compact size and universal mounting position allows it to be mounted in the motor, in the conduit box or remote from the motor. The balanced armature allows the relay to be mounted in any position. A wide range of pick up and drop out current ratings are available to fit almost any application. Replaces Klixon 2CR & 4CR series and RBM 91252 series relays, see cross reference chart for substitutions. If original relay number is not available, use the relay selection procedure to determine the proper relay to use. Overall dimensions are 1-7/8" long x 1-1/4" wide x 1-1/4" high. SL-10A series relays are two circuit design. If a one circuit design relay is required, simply add a jumper between the appropriate terminals.

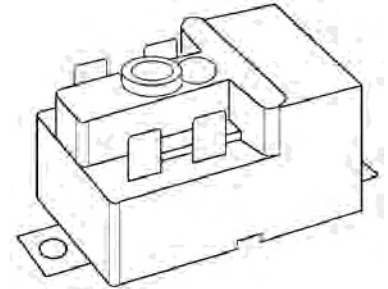

RELAY SELECTION PROCEDURE:

Step #1: Determine the minimum value drop out current (Point A)

- 1.) Start with motor windings at room temperature.
- 2.) Connect both the starting and running windings in the circuit. (If the motor is a capacitor start type the start capacitor should be in the circuit.)
- 3.) Voltage at the motor terminals should be 15% above rated.
- 4.) Bring the motor up to speed at rated load, disconnect the start winding.
- 5.) Immediately measure and record the current in the run winding only. This current must be measured before the windings rise in temperature since current drops off with temperature rise. (The recorded current reading is the Point A value.)

Step #2: Determine the maximum value of pick up current (Point B)

- 1.) Connect only the running winding in the circuit.
- 2.) Lock the rotor.
- 3.) Voltage at the motor terminals should be 20% below rated voltage.
- 4.) Energize the motor on the running winding only until the winding temperature is about 150°F.
- 5.) Immediately measure and record the current in the run winding. (The recorded current reading is the Point B value.)
- 6.) These values locate the allowable limits of the pick up and drop out currents for the particular motor. For good relay operation this 'application range' taken as a ratio of B to A should be 130% or more. ($B \setminus A = 1.3$ or more). If the ratio is less than 130% the application is questionable and this type of relay should not be used.

Step #3: Relay Selection

Select a coil rating from the table whose maximum pick up and minimum drop out currents bracket or fall slightly above the mid point between A and B. I.E. Point A is 3 amps point B is 5 amps choose coil rating 644 (Pick up 4.45 amps drop out 3.7 amps).

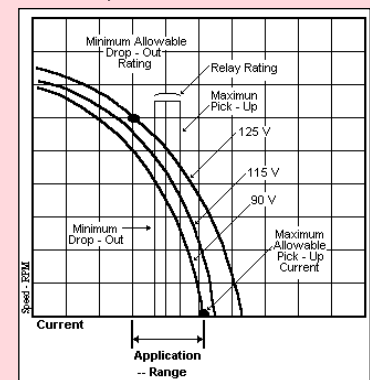

Test operation of relay under both high and low voltage conditions after mounting to ensure proper relay operation.

WIRING DIAGRAMS:

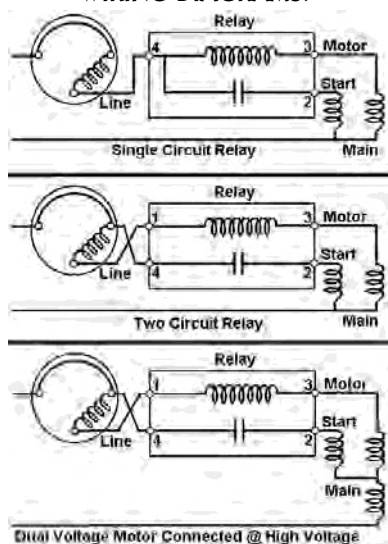

COIL RATINGS:		
MAXIMUM PICK UP (IN.)	MINIMUM DROP OUT (IN.)	PART NUMBER
0.75	0.64	SL-10A-919
0.96	0.79	SL-10A-599
1.12	0.93	SL-10A-602
1.22	1.01	SL-10A-604
1.47	1.22	SL-10A-609
1.68	1.38	SL-10A-613
1.83	1.51	SL-10A-616
2.03	1.68	SL-10A-620
2.33	1.92	SL-10A-623
2.54	2.10	SL-10A-625
2.74	2.26	SL-10A-627
2.95	2.45	SL-10A-629
3.15	2.60	SL-10A-631
3.55	2.95	SL-10A-635
3.85	3.20	SL-10A-638
4.15	3.45	SL-10A-641
4.45	3.70	SL-10A-644
4.75	3.95	SL-10A-647
5.10	4.20	SL-10A-650
5.60	4.60	SL-10A-655
6.00	4.95	SL-10A-659
6.30	5.20	SL-10A-662
6.80	5.60	SL-10A-667
7.30	6.00	SL-10A-672

COIL RATINGS:		
MAXIMUM PICK UP (IN.)	MINIMUM DROP OUT (IN.)	PART NUMBER
7.60	6.30	SL-10A-675
8.10	6.70	SL-10A-680
8.40	6.90	SL-10A-683
8.80	7.30	SL-10A-687
9.10	7.50	SL-10A-690
9.60	7.90	SL-10A-695
10.0	8.30	SL-10A-699
11.0	9.10	SL-10A-704
12.0	9.90	SL-10A-709
13.2	10.9	SL-10A-715
14.0	11.5	SL-10A-719
15.0	12.4	SL-10A-724
15.8	13.0	SL-10A-728
16.4	13.5	SL-10A-731
17.0	14.0	SL-10A-734
18.1	14.9	SL-10A-739
19.1	15.8	SL-10A-744
20.3	16.7	SL-10A-750
21.5	17.7	SL-10A-756
22.5	18.6	SL-10A-761
23.3	19.2	SL-10A-765
24.3	20.1	SL-10A-768
25.6	21.1	SL-10A-772
27.4	22.6	SL-10A-777

Intermediate coil ratings are available. See complete technical bulletin for more information.

STEARNS SINPAC[®] SOLID STATE SWITCHES

SINPAC[®] solid state switches are designed to replace conventional rotating and stationary switches, current sensitive, and voltage sensitive relay applications. There are no contacts and no moving parts to wear out, providing long life. No moving parts also means that the SINPAC[®] switch is perfect for high cycling applications. The SINPAC[®] switch senses motor RPM by sensing the induced voltage in the start winding. By comparing that induced voltage to applied voltage, the SINPAC[®] switch senses when the motor is at approximately 75 - 80% of full RPM and disconnects the start winding. Because the SINPAC[®] switch determines the voltage ratio between applied voltage and induced voltage, it works well in applications that encounter brown-out or low voltage conditions. In addition, the SINPAC[®] switch constantly monitors the ratio so if the motor encounters an overload condition and the RPM drops below 50% of synchronous speed, the SINPAC[®] automatically energizes the start winding until the motor comes back up to rated speed. Universal mounting positions and compact design make the SINPAC[®] switch an excellent choice for replacing old and obsolete mechanical switches and relays. UL recognized and approved by motor manufacturers.



DIMENSIONAL DRAWINGS

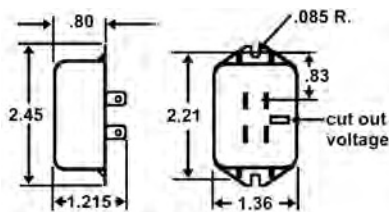

Case Style 11

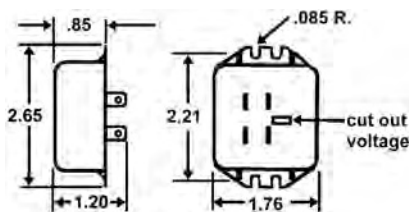

Case Style 12

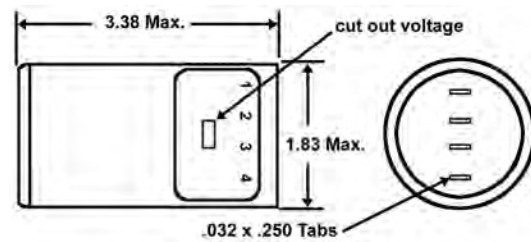

Case Style 15

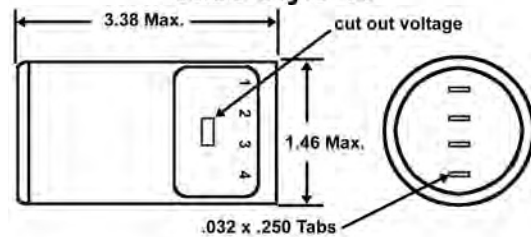

Case Style 19

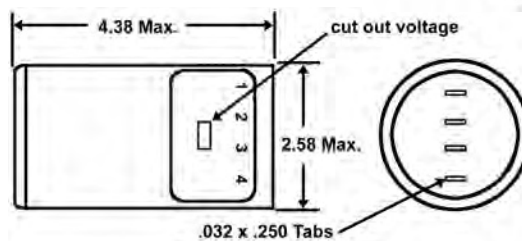

Case Style 17

STEARNS SINPAC^{‡‡} SOLID STATE SWITCHES

The following information is required to determine which SINPAC^{‡‡} switch to use.

1.) Type of Motor. Split Phase = PV; Capacitor Start = CV & CVR; Capacitor Start/Capacitor run = CVR & 2VR; Instant Reverse Capacitor Start = IR.

2.) Current Capacity. Choose by HP rating, or nameplate current rating or take a locked rotor current reading of the start winding. (A higher rated switch can be used on lower current requirements.)

3.) Start Winding Voltage. Determine the voltage at which the start winding operates. (Most dual voltage motors have 115 volt start windings).

4.) Cut Out Voltage. Most start windings have an induced voltage of 165% of applied voltage. Use the 165 cut out voltage switch for 115 volt applications, or the 310 cut out voltage switch for 230 volt applications. Occasionally you will run into motor designs that have a lower voltage ratio and then you will need to use the lower cut out voltage switch. Induced voltage can be measured by running the motor momentarily with both the start & run winding connected in the circuit. As the motor is running, take a voltage reading across the start winding only. Use the SINPAC^{‡‡} switch that has the closest voltage cut out rating to the voltage measurement taken.

TYPICAL MAXIMUM MOTOR HP	TYPICAL FULL LOAD MOTOR NAMEPLATE CURRENT RATING (AMPS) 115 V 230 V	SWITCH RATING AND MAXIMUM START WINDING CURRENT (AMPS)	START WINDING VOLTAGE	CUT OUT VOLTAGE	CUT IN VOLTAGE	PACKAGE STYLE	PART NUMBER
PV SERIES FOR SPLIT PHASE MOTORS							
1/3	8 -	16	115	-	30	11	PV-16-30
1/3	8 -	16	115	-	10	11	PV-16-10
1/2	- 4	16	230	-	60	11	2PV-16-60
1/2	12 -	25	115	-	30	11	PV-25-30
1/2	12 -	25	115	-	10	11	PV-25-10
3/4	20 -	40	115	-	30	11	PV-40-30
CV SERIES FOR CAPACITOR START MOTORS							
1/2	8 -	16	115	165	37	11	CV-16-165
1/2	8 -	16	115	147	37	11	CV-16-147
1/2	8 -	16	115	130	29	11	CV-16-130
1	12 -	25	115	165	37	11	CV-25-165
1	12 -	25	115	147	37	11	CV-25-147
1	12 -	25	115	130	29	11	CV-25-130
2	20 -	40	115	165	37	11	CV-40-165
2	20 -	40	115	147	37	11	CV-40-147
2	20 -	40	115	130	29	11	CV-40-130
3	25 -	50	115	165	37	11	CV-50-165
3	25 -	50	115	147	37	11	CV-50-147
3	25 -	50	115	130	29	11	CV-50-130
3	- up to 17.5	35	230	260	70	15	2CV-35-260
3	- up to 17.5	35	230	310	70	15	2CV-35-310
5	- up to 25	50	230	260	70	15	2CV-50-260
5	- up to 25	50	230	310	70	15	2CV-50-310
2VR SERIES FOR CAPACITOR START & CAPACITOR START/CAPACITOR RUN MOTORS							
2	20 -	40	115	165	37	12	CVR-40-165
2	20 -	40	115	147	37	12	CVR-40-147
2	20 -	40	115	130	29	12	CVR-40-130
3	25 -	50	115	165	37	12	CVR-50-165
3	25 -	50	115	147	37	12	CVR-50-147
3	25 -	50	115	130	29	12	CVR-50-130
3 - 5	50 -	80	115	165	37	15	CVR-80-165
3 - 5	50 -	80	115	147	37	15	CVR-80-147
3 - 5	50 -	80	115	130	29	15	CVR-80-130
5 - 7-1/2	- 35	70	230	310	70	17	2CVR-70-310
5 - 7-1/2	- 35	70	230	260	70	17	2CVR-70-260
up to 10	- 45	90	230	310	70	17	2CVR-90-310
up to 10	- 45	90	230	230	70	17	2CVR-90-230
2VR SERIES FOR CAPACITOR START/CAPACITOR RUN MOTORS							
3	- up to 17.5	5	230	310	70	15	2VR-35-310
3	- up to 17.5	35	230	260	70	15	2VR-35-260
5	- up to 25	50	230	310	70	15	2VR-50-310
5	- up to 25	50	230	260	70	15	2VR-50-260
IR SERIES FOR INSTANT REVERSE CAPACITOR START MOTORS							
1/2	12 -	25	115	165	37	15	IR-25-165
1/2	12 -	25	115	147	37	15	IR-25-147
1/2	12 -	25	115	130	29	15	IR-25-130
2	20 -	40	115	165	37	15	IR-40-165
2	20 -	40	115	147	37	15	IR-40-147
2	20 -	40	115	130	29	15	IR-40-130

‡‡ Sinpac is a registered trademark of Rexnord Corporation, Stearns Division.

MACROSTART^{SS} SOLID STATE SWITCHES

- Reduced Labor Cost
- Easy Installation
- Reduced Inventory Requirements
- No Contacts To Degrade
- Sealed Unit - Impervious to dust & moisture
- Replaces Obsolete Switches
- Performance documented at well over 1,000,000 start cycles

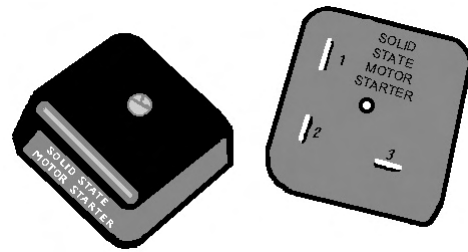

The MACROSTART^{SS} solid state switch is a time sensitive switch. It will disconnect the start winding after a specified period of time. This switch will work on split phase and capacitor start motors operating at 860 to 3450 RPM. It is compact in size and sealed to prevent dirt and moisture from entering the switch, and it can be mounted in any position. MACROSTART^{SS} has determined that a motor installed in an application will start in a specific period of time. For instance, a motor used in a water pump application will start in 1/3 second. If a motor stalls during run condition the power must be turned off in order to re-start the motor. The MACROSTART^{SS} will operate on 50 or 60 cycle, and voltages of 90 - 140 VAC or 200 - 260 VAC. Temperature range is 0-80°C. Physical dimension is 1-17/32" x 1-17/32" X 9/16" thick. Can be easily mounted via a #6 screw or by using an adhesive to secure it.

TYPICAL APPLICATION	MAX. TIME DELAY	START HP RATING	MAX. WINDING VOLTAGE	CURRENT RATING	PART NUMBER
Pump & Compressor Applications and motors with no starting load	1/3	2	115	20	STM-33-115
	1/3	2	230	10	STM-33-230
Waste Disposals & Fans or Cap Start motors with high starting load or Split Phase motors with low starting load.	1/2	2	115	20	STM-50-115
	1/2	2	230	10	STM-50-230
	1/2	5	115	30	STM-30-5-115
	1/2	5	230	30	STM-30-5-230
For Capacitor Start & Split Phase Motors starting under full load conditions.	1	2	115	20	STM-100-115
	1	2	230	10	STM-100-230
	1	5	115	30	STM-30-10-115
	1	5	230	30	STM-30-10-230

WIRING DIAGRAMS:

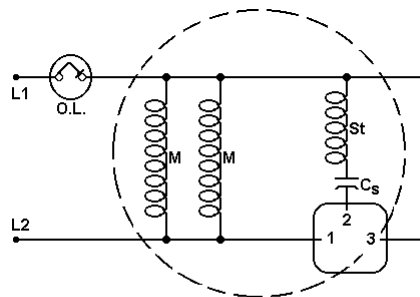

Connection For Single Voltage Motors or Dual Voltage at Low Voltage Connection For Split Phase Motors Disregard Start Capacitor

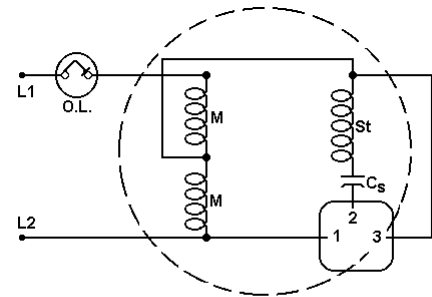

Connection For Dual Voltage Motors Connected At High Voltage For Split Phase Motors Disregard Start Capacitor

Caution: #2 terminal should never contact line power.
 Reversing terminal #1 & #2 will not allow motor to start.
 Reversing terminal #1 & #3 will damage the switch in 30 seconds.
 Reversing terminal #2 & #3 will cause the switch to fail immediately.

Mechanical "Instant Reverse" switches can be replaced by using two MACROSTART^{SS} switches. Request the instant reverse connection diagram to maintain the hookup of the original reversing switch, making it easy for the customer to

install the motor. MACROSTART^{SS} gives you the reliability and long life of an electronic switch. There are no contacts or moving parts to wear out.

KB ELECTRONICS SPEED CONTROLS

Designed for Speed Control of Shaded Pole, AC/DC-Universal and Permanent Split Capacitor (PSC) Motors.

TYPICAL APPLICATIONS:

Fans, Air Conditioners, Fireplace Blowers, Attic Fans, Humidifiers, Ventilators, Ceiling Fans, Range Hoods.

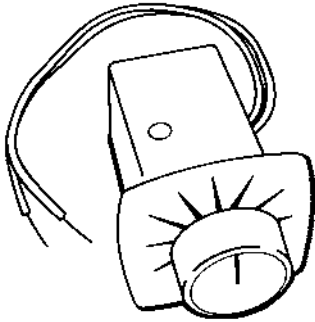

CASE STYLE A

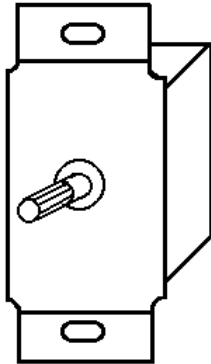

CASE STYLE B

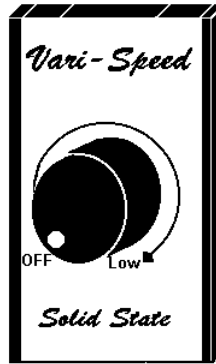

CASE STYLE D

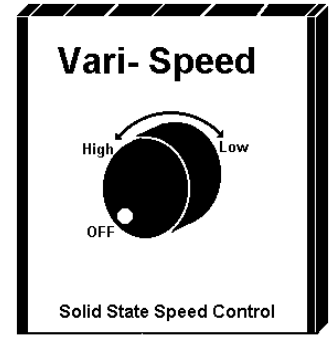

CASE STYLE E

The KB Series is a comprehensive line of motor speed controls for air-moving applications which utilize shaded pole, permanent split capacitor, and AC/DC-Universal motors. These economical controls are designed to replace obsolete tapped winding, or reactive methods of speed control. The full wave phase control circuitry minimizes power loss, thereby reduces energy requirements. The controls provide infinitely variable

speed adjustment which permits the consumer individual selection of air volume, motor speed, and noise level. The models cover a wide range of amperages from 2.5 through 15 amps which allow for the selection of the most economical control for the application. Important features are standard such as RFI filter, min. speed trim, and built-in on/off line switch. All models are UL recognized.

MAX. AMPS	MAX. AMB.	CASE STYLE	MOUNTING (IN.)	115 VOLT PART NUMBER	230 VOLT PART NUMBER
2.5	25	B	2x4 Gem Box	KBWC-13K	-
4	40	A	7/16 Hole	KBSC-14K	-
5	40	B	2x4 Gem Box	KBWC-15K	KBWC-25K
6	25	B	2x4 Gem Box	KBWC-16K	KBWC-26K
8	40	D	2x4 Gem Box	KBWC-18K	-
10	25	D	2x4 Gem Box	KBWC-110K	-
15	40	E	2x4 Gem Box	KBWC-115K	KBWC-215K

CASE DIMENSIONS

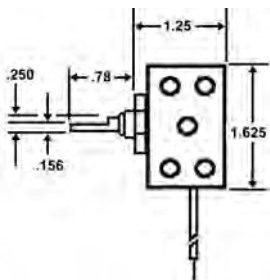

A Case Dimensions

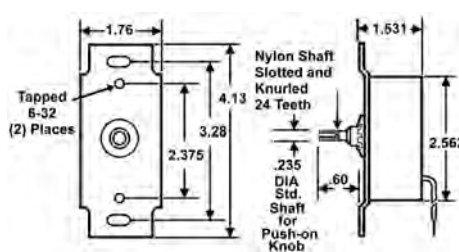

B Case Dimensions

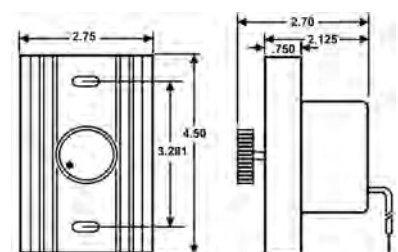

D Case Dimensions

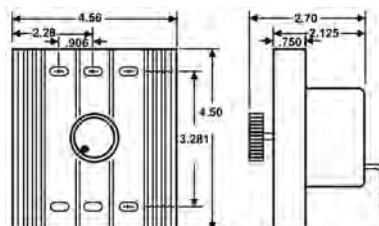

E Case Dimensions

GENERAL PURPOSE RELAYS

FAN RELAYS

WR/RBM TYPE 84 Relays are totally enclosed. Relay comes single pole normally open or single pole double throw. Used for switching single or two speed fan motors, solenoids. Relays, resistive loads and general purpose switching.

- Coil Frequency - 50/60 Hz
- Coils Operate - 85% of nominal voltage; 110% maximum safe operate
- UL File No.: E12139 or E22381
- CSA File No.: LR13360
- Duty Cycle - continuous



CURRENT RATING		# OF POLES	CONTACT ARRANGEMENT	COIL VOLTAGE	PART NUMBER
INDUCTIVE	RESISTIVE				
8	16	1	SP/NO	24	CP-290Q
8	16	1	SP/NO	115/120	CP-291Q
8	16	1	SP/NO	208/240	CP-292Q
8	8	1	DT	24	CP-293Q
8	8	1	DT	115/120	CP-294Q
8	8	1	DT	208/240	CP-295Q

HEAVY DUTY FAN RELAYS

When you need a compact, totally enclosed relay with 50% more electrical range, (12 A.) that's quiet on the job ... select the CP-370 series. This heavy duty general purpose relay operates in any position, plus enclosed design minimizes exposure to, and damage from elements. Plugs into receptacles. All good reasons to reach for Steveco. The CP-370 series is built to do a variety of jobs quietly, reliably and economically. It is perfect for applications involving: Air Conditioning, Heating, Appliances, Fan control, and General Purpose Switching

- Coil Frequency - 50/60 Hz
- Operate - 85% of nominal voltage; 110% maximum safe operate
- Duty Cycle - Continuous ** Current rating at 120/240 Volts.



CURRENT RATING		# OF POLES	CONTACT ARRANGEMENT	COIL VOLTAGE	PART NUMBER
INDUCTIVE	RESISTIVE				
12/8 **	18	1	SP/NO	24	CP-360
12/8 **	18	1	SP/NO	115/120	CP-362
12/8 **	18	1	SP/NO	208/240	CP-364
12/8 **	18	1	DT	24	CP-370
12/8 **	18	1	DT	115/120	CP-372
12/8 **	18	1	DT	208/240	CP-374
12/8 **	18	2	DP/ST	24	CP-380

2 POLE SWITCHING RELAY

WR/RBM Type 91. A two pole double throw semi-enclosed relay. Easy to install and wire. Relay available for power or pilot duty. Suited for vending machines, appliances, fan controls, heating and air conditioning applications and general purpose switching.

- UL File No.: E12139 C.S.A. File No.: LR13360
- Coil Frequency - 50/60 Hz
- Operate - 85% of nominal coil voltage; 110% maximum safe operate



CURRENT RATING		# OF POLES	CONTACT ARRANGEMENT	COIL VOLTAGE	PART NUMBER
INDUCTIVE	RESISTIVE				
13.8	15	2	DT	24	RBM-90-340
13.8	15	2	DT	115/120	RBM-90-341
13.8	15	2	DT	208/240	RBM-90-342
13.8 / 3	15 / 3	2*	DT	24	RBM-90-343
13.8 / 3	15 / 3	2*	DT	115/120	RBM-90-344
13.8 / 3	15 / 3	2*	DT	208/240	RBM-90-345
3	3	2	DT	24	RBM-90-346

GENERAL PURPOSE RELAYS

SWITCHING RELAY

WR/RBM type 129000 replaces RBM 91256 features screw or quick connect terminals and a variety of mountings.

- UL File No.: E12139 CSA File No.: LR13360
- Coil Frequency - 50/60 Hz.
- Operate 85% of nominal coil voltage
- 110% maximum safe operate



CURRENT RATING		# OF POLES	CONTACT ARRANGEMENT	COIL VOLTAGE	PART NUMBER
INDUCTIVE	RESISTIVE				
10	18	1	DT	115	RBM-90-101
10	18	1	DT	208/230	RBM-90-103
10	18	1	DT	24	RBM-90-105

INDUSTRIAL POWER RELAY

Class 8501 Type C relays are ideally suited for controlling small single phase motors and other light loads such as electric heaters, pilot lights or audible signals.

- 1-1/2 Horsepower Rating
- UL Listed
- CSA Certified
- Visible Contacts
- Low Cost



CURRENT RATING		# OF POLES	CONTACT ARRANGEMENT	COIL VOLTAGE	PART NUMBER
INDUCTIVE	RESISTIVE				
25	30	1	DT	24	SQD-5A-24
25	30	1	DT	120	SQD-5A-120
25	30	1	DT	240	SQD-5A-240
25	30	2	ST	24	SQD-7A-24
25	30	2	ST	120	SQD-7A-120
25	30	2	ST	240	SQD-7A-240
25	30	2	DT	24	SQD-11A-24
25	30	2	DT	120	SQD-11A-120
25	30	2	DT	240	SQD-11A-240

DEFINITE PURPOSE CONTACTORS

Leland Faraday definite purpose contactors are ideal for heating, air conditioning, refrigeration, data processing, and food service equipment. New compact 1 and 2 pole contactors are available along with standard 2, 3, and 4 pole devices. They feature quick connect terminals and binder head screws for easy wiring. Box lugs are standard on 40 ampere contactors and larger. An exclusive DIN track mounting option may reduce installation costs. Coils can be changed on the type DPA contactors quickly without a tool. Auxiliary contact modules snap on either side of the type DPA contactors.



- Compact Design
- Industry Standard Mounting
- Double Break Contacts
- Low Coil VA
- Straight-Through Wiring
- Low Cost

COMPACT 1 POLE CONTACTORS - 300V AC MAXIMUM								
FULL LOAD AMPERES	LOCKED ROTOR AMPERES		RESISTIVE LOAD AMPERES	HP RATINGS		NUMBER OF POLES	COIL VOLTAGE	PART NUMBER
	277V	277V		115V 1PH	230V 1PH			
30	150	150	30	2	3	1	24	SQD-DP31-V14
							120	SQD-DP31-V02
							208-240	SQD-DP31-V09

COMPACT 2 POLE CONTACTORS - 600V AC MAXIMUM. ⁽¹⁾								
FULL LOAD AMPERES	LOCKED ROTOR AMPERES			RESISTIVE LOAD AMPERES	HP RATINGS		NUMBER OF POLES	PART NUMBER
	277V	400V	575V		115V 1PH	220V 1PH		
30	150	150	120	40	2	5	2	LF302##
40	240	200	160	50	2	5	2	LF402##

##Voltage code must be specified to order this product, refer to Coil Selection Table below, i.e.: LF30210 is 24V coil.

⁽¹⁾ Above 240 volts, all lines must be switched.

2, 3, AND 4 POLE CONTACTORS - 600V AC MAXIMUM. ⁽¹⁾										
FULL LOAD AMPERES	LOCKED ROTOR AMPERES			RESISTIVE LOAD AMPERES	HORSEPOWER RATINGS				NUMBER OF POLES	PART NUMBER
	277W	400V	575V		115V 1PH	220V 1PH	230V 3PH	460/575V 3PH		
20	120	100	80	25	1	2	5	7-1/2	3	LF130##
25	150	125	100	25	2	2	7-1/2	10	2	LF220##
									3	LF230##
30	180	150	120	40	2	5	10	15	2	LF320##
									3	LF330##
									4	LF340##
40	240	200	160	60	3	7-1/2	10	20	2	LF420##
									3	LF430##
									4	LF440##
50	300	250	200	62	3	10	15	30	3	LF530##
60	360	300	240	75	5	10	25	30	3	LF630##
75	450	275	200	94	5	15	25	40	3	LF730##
90	540	450	360	120	7-1/2	20	20	50	3	LF930##
120	720	600	480	120	7-1/2	20	30	50	3	LF123##

##Voltage code must be specified to order this product, refer to Coil Selection Table below, i.e.: LF33010 is 24V coil.

⁽¹⁾ Above 240 volts, all lines must be switched.

COIL SELECTION TABLE		
COIL VOLTAGE (VAC)	CONTACTOR VOLTAGE CODE	REPLACEMENT COIL VOLTAGE CODE
24	10	V14
120	20	V02
208-240	30	V09
277	50	V04
480	60	V06

REPLACEMENT COIL SELECTION TABLE		
CONTACTOR AMPERES RATING	REPLACEMENT # OF POLES	COIL PART NUMBER
20 - 40	2 & 3	LFDA1###
20 - 40	4	LFDA2###
50 - 60	2 & 3	LFDA2###
75 - 90	2 & 3	LFDA3###

Insert Replacement Coil Voltage Code From Coil Selection Table Left.

AUXILLARY CONTACT SELECTION CHART	
For use with 2, 3, and 4 pole contactors. (Standard size only)	
CONTACT ARRANGEMENT	PART NUMBER
1 N.O.	LF8910-D10
1 N.C.	LF8910-D01
1 N.O. & 1 N.C.	LF8910-D11
2 N.O.	LF8910-D20

THERMAL PROTECTION DEVICES

KLIXON[®] OVERLOAD PROTECTORS

Since first introduced, many millions of KLIXON[®] Protectors have been installed in motors throughout the world. From one protector size and design, the line has grown into a wide series of sizes and ratings to meet the requirements of different type motors, from shaded-pole fractionals through single and three-phase integrals, and from commercial and aircraft motors to hermetically sealed, compressor motors. Inherent protectors operate by means of a KLIXON snap-acting, thermostatic, bimetal disc and a heater. The contacts are mounted on the disc and the circuit is normally closed. Motor current passes through both the disc and the heater. When the temperature of the disc reaches a predetermined calibration point, the disc snaps to reverse curvature, separating the contacts and opening the circuit. Protector terminals are a part of the thermal device and make thermal contact with the disc through the silver contacts. Therefore, any heat added to or taken away at the terminals will affect the operation of the device. Care should be taken to assure good and permanent connections at the terminals. This positive snap-action of the KLIXON disc makes the protector especially resistant to vibration; moreover, the disc operates dependably without the aid of accessory springs, cams, toggles or overcenter mechanisms.

The following is an explanation of the type code which appears on each standard end bell or dome mounted KLIXON protector. By using this code, it is possible to determine the following: size, type of base, terminals, heater, type disc and contacts, and operating temperature.

M R P 36 G X - 63

LEAD SPECIFICATIONS

SIZE	BASE Single Phase	TERMINALS Single Phase	HEATER	DISC & CONTACT SINGLE PHASE	OPERATING TEMPERATURE AUTOMATIC RESET																																																																																																																										
M = 3/4" C = 1" B = 1-1/4" L = 1-1/2"	E = Eared Commercial R = Round Commercial C = Round Commercial Cut Down & Cover G* = Eared Commercial and Cover S* = Round Commercial and Cover W = Eared Commercial Y = Round Commercial	F = 2 Solder Low Cap H = 2 Solder High Cap K 2 Std Screw Low Cap M = 2 Std Screw High Cap P = 2 Stub Low Cap T = 2 Stub High Cap G = 3 Solder Low Cap J = 3 Solder High Cap L = 3 Std Screw Low Cap O = 3 Std Screw High Cap P = 3 Stub Low Cap T = 3 Stub High Cap Three Phase H = 3 Solder High Cap J = 6 Solder High Cap T = 3 Stub High Cap V = 6 Stub High Cap	Selected to satisfy application requirements Each heater is specified for each particular motor, No substitution allowed	<table border="1"> <thead> <tr> <th colspan="2">3/4"</th> <th colspan="2">1"</th> </tr> <tr> <th>High Cap.</th> <th>Low Cap.</th> <th>High Cap.</th> <th>Low Cap.</th> </tr> </thead> <tbody> <tr><td>A</td><td>Y</td><td>F</td><td>C</td></tr> <tr><td>B</td><td>AB</td><td>F</td><td>C</td></tr> <tr><td>C</td><td>AE</td><td>G</td><td>D</td></tr> <tr><td>D</td><td>AF</td><td>J</td><td>E</td></tr> <tr><td>E</td><td>AG</td><td>L</td><td>H</td></tr> <tr><td>F</td><td>AH</td><td>N</td><td>I</td></tr> <tr><td>G</td><td>AI</td><td>O</td><td>K</td></tr> <tr><td>H</td><td>AJ</td><td>P</td><td>S</td></tr> <tr><td>I</td><td>AK</td><td>T</td><td>U</td></tr> <tr><td>J</td><td>AL</td><td>AB</td><td>W</td></tr> <tr><td>K</td><td>AM</td><td>AE</td><td>X</td></tr> <tr><td>L</td><td>AP</td><td>AF</td><td>Y</td></tr> <tr><td>N</td><td>AG</td><td></td><td></td></tr> <tr><td>O</td><td>AH</td><td></td><td></td></tr> <tr><td>R</td><td>AI</td><td></td><td></td></tr> <tr><td>S</td><td>AJ</td><td></td><td></td></tr> <tr><td>T</td><td>AK</td><td></td><td></td></tr> <tr><td>U</td><td>AL</td><td></td><td></td></tr> <tr><td></td><td>AM</td><td></td><td></td></tr> <tr><td></td><td>AN</td><td></td><td></td></tr> </tbody> </table>	3/4"		1"		High Cap.	Low Cap.	High Cap.	Low Cap.	A	Y	F	C	B	AB	F	C	C	AE	G	D	D	AF	J	E	E	AG	L	H	F	AH	N	I	G	AI	O	K	H	AJ	P	S	I	AK	T	U	J	AL	AB	W	K	AM	AE	X	L	AP	AF	Y	N	AG			O	AH			R	AI			S	AJ			T	AK			U	AL				AM				AN			<table border="1"> <thead> <tr> <th>Open ±5°</th> <th>Close ±9°C</th> </tr> </thead> <tbody> <tr><td>J = 90</td><td>57**</td></tr> <tr><td>K = 105</td><td>61</td></tr> <tr><td>L = 105</td><td>69</td></tr> <tr><td>V = 105</td><td>78</td></tr> <tr><td>Z = 120</td><td>61</td></tr> <tr><td>N = 120</td><td>69</td></tr> <tr><td>X = 120</td><td>78</td></tr> <tr><td>Y = 120</td><td>92</td></tr> <tr><td>W = 135</td><td>61</td></tr> <tr><td>U = 135</td><td>69</td></tr> <tr><td>M = 135</td><td>78</td></tr> <tr><td>R = 135</td><td>92</td></tr> <tr><td>S = 135</td><td>102</td></tr> <tr><td>H** = 150**</td><td>78**</td></tr> <tr><td>P** = 150**</td><td>115**</td></tr> <tr><td>O** = 150**</td><td>102**</td></tr> </tbody> </table>	Open ±5°	Close ±9°C	J = 90	57**	K = 105	61	L = 105	69	V = 105	78	Z = 120	61	N = 120	69	X = 120	78	Y = 120	92	W = 135	61	U = 135	69	M = 135	78	R = 135	92	S = 135	102	H** = 150**	78**	P** = 150**	115**	O** = 150**	102**
3/4"		1"																																																																																																																													
High Cap.	Low Cap.	High Cap.	Low Cap.																																																																																																																												
A	Y	F	C																																																																																																																												
B	AB	F	C																																																																																																																												
C	AE	G	D																																																																																																																												
D	AF	J	E																																																																																																																												
E	AG	L	H																																																																																																																												
F	AH	N	I																																																																																																																												
G	AI	O	K																																																																																																																												
H	AJ	P	S																																																																																																																												
I	AK	T	U																																																																																																																												
J	AL	AB	W																																																																																																																												
K	AM	AE	X																																																																																																																												
L	AP	AF	Y																																																																																																																												
N	AG																																																																																																																														
O	AH																																																																																																																														
R	AI																																																																																																																														
S	AJ																																																																																																																														
T	AK																																																																																																																														
U	AL																																																																																																																														
	AM																																																																																																																														
	AN																																																																																																																														
Open ±5°	Close ±9°C																																																																																																																														
J = 90	57**																																																																																																																														
K = 105	61																																																																																																																														
L = 105	69																																																																																																																														
V = 105	78																																																																																																																														
Z = 120	61																																																																																																																														
N = 120	69																																																																																																																														
X = 120	78																																																																																																																														
Y = 120	92																																																																																																																														
W = 135	61																																																																																																																														
U = 135	69																																																																																																																														
M = 135	78																																																																																																																														
R = 135	92																																																																																																																														
S = 135	102																																																																																																																														
H** = 150**	78**																																																																																																																														
P** = 150**	115**																																																																																																																														
O** = 150**	102**																																																																																																																														
Designates Diameter of Disc inside Klixon. No Substitution Allowed.	Designates Mounting Characteristics. Substitution should be done only if different mounting can be accommodated. * Except 1-1/4" which always has cover E & R designate this.	Designates terminals okay to substitute high capacity for low capacity. Solder terminal should be substituted for all applications. Soldering to stub terminal could damage overload. 2 Terminal design can be substituted with 3 terminal disregard terminal #2. Use Style J Terminal.		Designates current carrying capacity and reaction time of disc to change in temperature. Allowable substitution F with a C, P with a D or G with a E is acceptable.	<table border="1"> <thead> <tr> <th colspan="2">MANUAL REST</th> </tr> <tr> <th>Open ±5°</th> <th>Close ±12°C</th> </tr> </thead> <tbody> <tr><td>G = 90</td><td>54**</td></tr> <tr><td>F = 105</td><td>63***</td></tr> <tr><td>A = 105</td><td>74*</td></tr> <tr><td>B = 120</td><td>74</td></tr> <tr><td>D = 135</td><td>97</td></tr> <tr><td>E** = 150**</td><td>97**</td></tr> </tbody> </table>	MANUAL REST		Open ±5°	Close ±12°C	G = 90	54**	F = 105	63***	A = 105	74*	B = 120	74	D = 135	97	E** = 150**	97**																																																																																																										
MANUAL REST																																																																																																																															
Open ±5°	Close ±12°C																																																																																																																														
G = 90	54**																																																																																																																														
F = 105	63***																																																																																																																														
A = 105	74*																																																																																																																														
B = 120	74																																																																																																																														
D = 135	97																																																																																																																														
E** = 150**	97**																																																																																																																														

Example Substitution

Reference KLIXON[®] is a part number CET-36FB which is a 1" diameter disc, eared base, 2 stub terminal, low capacity disc and contact, manual reset @ 120° C. You can substitute a CEJ-36CB, which is a 1" diameter disc, eared base, 3 Solder terminal, high capacity disc and contact, manual reset @ 120° C. Disregard terminal 2 (Remember, the KLIXON[®] Protector may react faster or slower to a change in temperature.)

Single Phase Connection

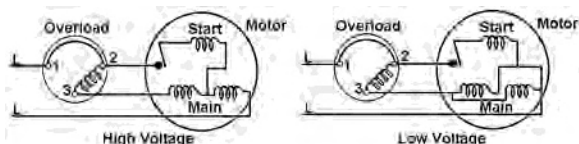

Three Phase Connection

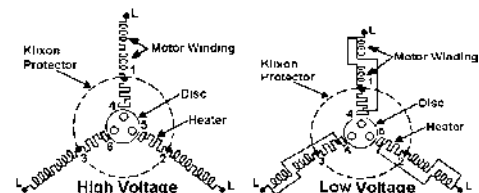

Extreme care must be taken when making substitutions. If the application could cause personal injury no substitution should be made. Any substitutions are entirely the customers decision, and no responsibility is accepted by Texas Instruments or Essex Group, Inc. for any damage or loss due to substitution.

[®] Klixon is a registered trademark of Texas Instruments.

THERMAL PROTECTION DEVICES

RESISTANCE TEMPERATURE DETECTORS (RTD'S)

Resistance temperature detectors offer several advantages over other types of winding temperature sensors. Because the resistance of the RTD has a lineal rise in relation to temperature, the exact temperature of the winding is known at all times. Therefore the trip temperature is not determined at the time the sensors are installed, allowing the controller to be set to the optimum trip temperature for the application. RTD overheat control systems offer the flexibility to adjust the trip temperatures in the field, avoiding nuisance trips. Some controllers can be set to sound an alarm at one temperature, then shut down the motor at a higher temperature.

Essex Brownell stocks two types of winding RTD to allow flexibility in installation:

Slot Type:

The slot type RTD is a flat, laminated "stick" RTD designed to fit in the slot between stator windings to monitor temperature rise and prevent overheating. The sensing elements are through most of the body length to provide an average temperature reading, eliminating the possibility of missing a localized hot spot.

Class H temperature rating.

End Turn Type:

The sensing element is laminated between KAPTON* film to provide flexibility and Class H temperature rating. Designed to mount in the end turns instead of the slot. Use it for small motors and retrofit applications.

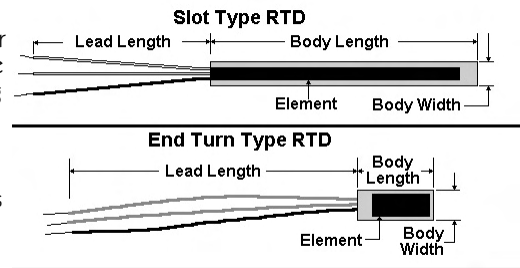

SENSOR DIMENSIONS			LEADS		ELEMENT TYPE		
TYPE	THICKNESS(IN.)	WIDTH(IN.)	LENGTH(IN.)	GA. X LENGTH	100Ω PLATINUM	10Ω COPPER	120Ω NICKEL
Slot	.078	.260	10	18 x 72"	RTD-H-S11	RTD-H-S3	RTD-H-S4
Slot	.030	.260	10	22 x 72"	RTD-S-S11-030	RTD-H-S3-030	RTD-H-S4-030
End Turn	.020	.500	1-1/4	26 x 72"	RTD-H-S11-ET	RTD-H-S3-ET	RTD-H-S4-ET

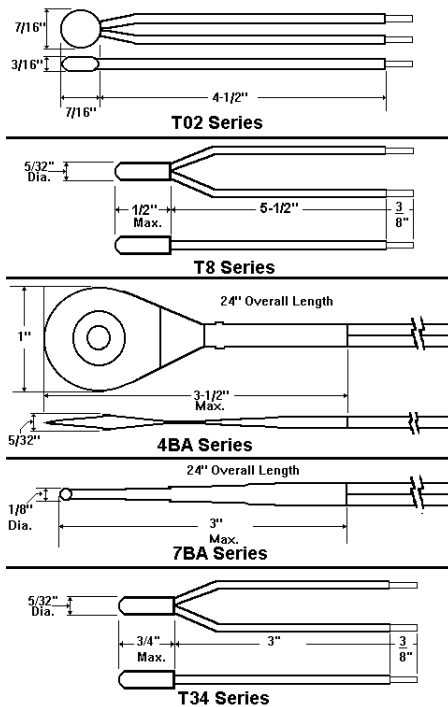

PTC THERMISTORS

PTC thermistors operate similarly to thermostats in that they have a specified trip temperature. The advantage of thermistors is that they are usually smaller in physical size and react to a temperature change quicker than thermostats. Many thermistor protection systems also offer a separate alarm circuit that will sound an alarm or light a light as the motor approaches overheat condition. The typical alarm sensor is 15° - 20°C below the rated motor shut down temperature. Thermistor controllers also offer fail safe protection because the controller checks for the sensors cold ohm rating to ensure that the thermistors are in operating condition. When choosing a replacement thermistor for an application, two primary specifications must be known.

1.) **Cold ohm rating.** This can be determined by taking an ohm reading on the sensor before the motor is burnt out. Remember, thermistors are usually connected in a series, make sure that the ohm reading is for only one thermistor or you can take the average of three thermistors connected in the series. By determining which controller is being used, you can also determine which thermistor to use.

2.) **Trip Temperature.** The trip temperature is usually indicated on the sensor. You can choose a temperature based on the original insulation class rating of the motor.

Insulation Class	A	B	F	H
Sensor Temp. Range	110°-120°C	130°-145°C	150°-165°C	150°-180°C
Most Common Sensor	120°C	135°C	160°C	180°C
Alarm Sensor Range	100°-105°C	115°-120°C	140°-145°C	160°-155°C

An important note to remember: just because the motor is being rewound with a higher temperature class insulation doesn't mean the motor is designed to handle the higher operating temperatures. Make sure the selection is based on the original temperature class rating of the motor. The last decision to make is which physical dimension to use. Most sensors are only offered in one style. Klixon offers sensor in two configurations, the bead type and the foil type.

THERMISTOR SERIES	THERMISTOR SELECTION CHART				
	T8 SERIES	4BA SERIES	7BA SERIES	T34H SERIES	T02 SERIES
CONTROL MANUFACTURER	MOTOGARD	KLIXON	KLIXON	BROWN - BOVERI	GUARDISTOR
Cold Ohm Resistance	150 - 500Ω	500 - 2500Ω	500 - 2500Ω	20 - 200Ω	10 - 60Ω
Part Number	T8###	4BA-###-1005	7BA-###-1005	T34H###	T02-##

4 Temperature ranges available H02 = 105°C, H05 = 125°C, H09 = 150°C, H13 = 170°C

Insert temperature to complete part number (i.e. T8155 = a T8 series thermistor that trips at 155°C)

* Kapton is a registered trademark of E.I. DuPont de Nemours.



THERMAL PROTECTION DEVICES

KLIXON™ THERMOSTAT KIT'S

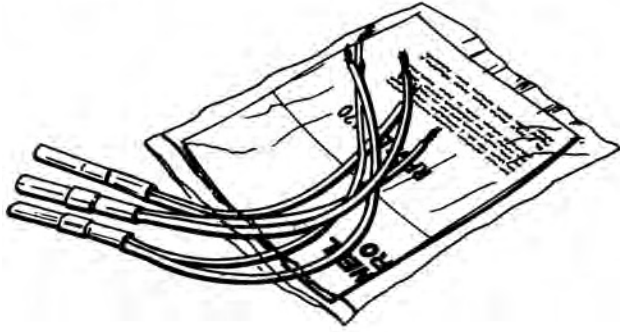

RFG-SL-11 KITS

Epoxy sealed thermostats for general purpose applications. The 9700K thermostat used in kits RFG-SL-11-90 through RFG-SL-11-150 are UL component recognized for hazardous location motor enclosure use at 720VA (pilot duty). UL File E34618.

RFG-SL-9 KITS

High reliability sealed thermostats for refrigeration motors, hazardous atmospheres, rugged service.



TRIP TEMP.	SL-9 SERIES PART NUMBER	SL-11 SERIES PART NUMBER
75°	RFG-SL-9-1	RFG-SL-11-75
85°	RFG-SL-9-2	-
90°	RFG-SL-9-3	RFG-SL-11-90
95°	RFG-SL-9-4	-
100°	RFG-SL-9-5	RFG-SL-11-100
105°	RFG-SL-9-6	-
110°	RFG-SL-9-7	RFG-SL-11-110
115°	RFG-SL-9-8	-
120°	RFG-SL-9-9	RFG-SL-11-120
130°	-	RFG-SL-11-130
135°	RFG-SL-9-10	RFG-SL-11-135
140°	-	RFG-SL-11-140
145°	-	RFG-SL-11-145
150°	-	RFG-SL-11-150

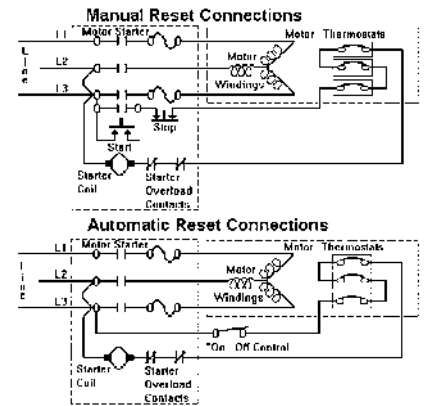

THERMOSTAT SELECTION PROCEDURE

THERMOSTAT SELECTION CHART THERMOSTAT TIED ON END TURNS				
INSULATION	A	B	F	H
Class	(105°C)	(130°C)	(155°C)	(180°C)
ODP Enclosure	105°	117.5°	130°	142.5°
TEFC Enclosure	110°	122.5°	135°	147.5°
TENV Enclosure	115°	127.5°	140°	152.5°
THERMOSTAT BURIED IN WINDINGS				
INSULATION	A	B	F	H
Class	(105°C)	(130°C)	(155°C)	(180°C)
ODP Enclosure	120°	132.5°	145°	157.5°
TEFC Enclosure	125°	137.5°	150°	162.5°
TENV Enclosure	130°	142.5°	155°	167.5°

The selection chart has been developed using standard 40°C ambient temperature rating with a 90°C temperature rise. To determine the proper thermostat rating for a specific motor use, the following formula.

1.) Determine UL Maximum Allowed Running Temperature.

UL MAXIMUM ALLOWED RUNNING TEMPERATURE				
INSULATION CLASS	A	B	F	H
Max. Operating Temp.	140°C	165°C	190°C	215°C

2.) Determine the normal running temperature. Add the ambient temperature rating and the temperature rise rating of the specific motor.

3.) Determine the midpoint between Max. Allowed temperature and normal running temperature.

4.) Subtract the gradient rating for the position that fits the thermostat installation position.

TYPICAL GRADIENTS MOTOR ENCLOSURE			
THERMOSTAT LOCATION	ODP	TEFC	TENV
Tied On End Turns	30°C	25°C	20°C
Buried In Windings	15°C	10°C	5°C

5.) Result is thermostat temperature rating.

I.E. Motor is a TEFC, has Class F Insulation, standard 40°C Ambient with a 55°C temperature Rise. Thermostat will be tied on to end turns. Maximum Allowed UL Running Temperature is 190°C. Normal running temperature is 95°C. Midpoint is 142.5. Subtract the gradient of 25° thermostat temperature rating is 117.5°C. Use thermostat with a 115° or 120°C rating.

Installation Notes:

- 1.) Install thermostat as far as possible from any air flow.
- 2.) Tie thermostat firmly in place to aid in heat transfer & reduce temperature gradient.
- 3.) Install one thermostat in each phase winding.
- 4.) Do not remove MYLAR* sleeve, this is needed for insulation.
- 5.) If the motor is to be dipped & baked, oven temperature should not exceed 300°F.
- 6.) Wire thermostats in series with the starter coil.
- 7.) SL Series thermostat kits provide overheat protection only. Current overloads in the starter are required for locked rotor protection.
- 8.) SL series thermostats will handle starter coil sizes through NEMA size 5 starters and the control relays in most large size starters.

™ Klixon is a registered trademark of Texas Instruments.

* Mylar is a registered trademark of E.I. DuPont de Nemours.

ABRASIVES



3M BLUE GRIT ABRASIVE CLOTH

Get the "TRUE BLUE" advantage with 3M Blue Grit abrasive. A tough abrasive bonded to cloth with a heat resistant resin. This special bonding technique provides a more uniform coating of abrasive which gives a more consistent scratch pattern. Tough, sharp, and long lasting, the special bonding resin stands up to heat better than conventional glue bonding techniques. Non-conductive abrasive makes this product a perfect choice for electrical/electronic applications.

3M abrasive cloth can be used in a variety of applications. Great for cleaning commutators, seating brushes, cleaning rust off shafts, and all general maintenance work. The cloth backing is flexible allowing you to get into tight areas. Available in 9" x 11" sheets and rolls up to 12" wide and 50 yards long.



WIDTH (IN.)	LENGTH	ROLLS					
		80 GRIT	120 GRIT	150 GRIT	180 GRIT	220 GRIT	
1	50 yds.	3M-05110	3M-05108	3M-05107	3M-05106	3M-05105	
1-1/2	50 yds.	3M-05125	3M-05123	3M-05122	3M-05121	3M-05120	
2	50 yds.	3M-05140	3M-05138	3M-05137	3M-05136	3M-05135	
3	50 yds.	3M-03X080	Spec. Order	3M-03X150	Spec. Order	3M-03X220	
4	50 yds.	3M-04X080	Spec. Order	3M-04X150	Spec. Order	3M-04X220	
6	50 yds.	3M-06X080	Spec. Order	3M-06X150	Spec. Order	3M-06X220	
SHEETS							
8	50 yds.	3M-08X080	Spec. Order	3M-08X150	Spec. Order	3M-08X220	
12	50 yds.	3M-12X080	Spec. Order	3M-12X150	Spec. Order	3M-12X220	
9	11"	3M-02460	3M-02458	3M-02457	3M-02456	3M-02455	

ROLOC DISC PADS

Rubber back-up pads are available in a variety of hardnesses for a variety of grinding applications. Pads are internally threaded to receive any standard 1/4"-20 threaded shaft. Minimum order case quantity.



DIAMETER (IN.)	HARDNESS	MAXIMUM RPM	CASE QUANTITY	PART NUMBER
1/4	Threaded Shaft		1	3M-45102
2	Soft	20,000	5	3M-45094
2	Medium	25,000	5	3M-45095
2	Hard	25,000	5	3M-45096
3	Soft	15,000	5	3M-45090
3	Medium	18,000	5	3M-45092
3	Hard	20,000	5	3M-45091

3M CLEAN AND STRIP DISCS

Designed for stripping away oxide, scale and rust from metal surfaces, particularly when conformance on an uneven surface is necessary. For heavy duty jobs such as cleaning metal surfaces, conditioning welds and removing coatings on electric motors.



PRODUCT	MINERAL TYPE	COLOR	GRADE	BACK
Clean	S	Black	XCS	1" - 30"
Part Number: 3M-00948 SXCS, 6x1/2, 20 Disc/Unit				

ROLOC SURFACE CONDITIONING DISCS

A complete abrasive system that revolves around a simple holding pad. ROLOC surface conditioning discs can be used on 3M's Roloc coated abrasive disc holding the system with the convenience of a twist-lock, positive centering device.



Provides the most complete abrasive disc system available.

PRODUCT	MINERAL TYPE	COLOR	GRADE	BACK
Roloc	-	Brown	CRS	Discs have
Surface	-	Maroon	MED	Roloc
Conditioning	A	Blue	VFN	buttons applied to back of disc
	S	Gray	SFN	
Part Number: 3M-05528 ACRS 2xNH Size 2", 200 Disc/Unit				
Part Number: 3M-05528 ACRS 3xNH Size 3", 100 Disc/Unit				

3M MANDRELS

These mandrels are made from corrosion resistant steel. They are designed for use with 3M unitized wheels. Length 3 1/16", Shank 1/4", Washer Diameter 2 1/2".



PART NUMBER 3M-04021

CRATEX® RUBBERIZED ABRASIVE WHEELS

Cratex large wheels have found wide application for smoothing, deburring and polishing. They resist clogging or glazing.



PART NUMBER	DIAMETER (IN.)	THICKNESS (IN.)	ARBOR HOLE (IN.)
TCX-408C	4	1/2	1/2
TCX-416C	4	1	1/2
TCX-608C	6	1/2	1/2
TCX-616C	6	1	1/2

3M STATOR CLEANING WHEELS

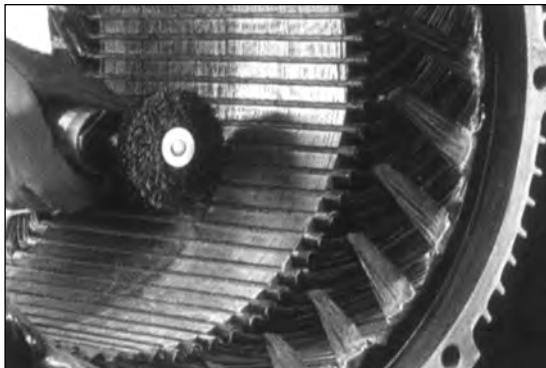

Possibly the best way to clean varnish off stators!

Made from non-conductive non-woven nylon material. Unitized wheels last longer than other wheels. Will not gum up.

SIZE O.D. X TH X I.D. (IN.)	PART NUMBER	MANDREL PART NUMBER
1 x 1 x 3/16	3M-01003	3M-04018
2 x 1/2 x 1/4	3M-01005	3M-13968
3 x 1/2 x 1/4	3M-01009	3M-13968
3 x 1 x 1/4	3M-01012	3M-13968
3 x 1 x 1/2	3M-01015	3M-04021
4 x 1/2 x 1/4	3M-01016	3M-13968
4 x 1/2 x 1/2	3M-01018	3M-04021
4 x 1 x 1/4	3M-01021	3M-13968
4 x 1 x 1/2	3M-01023	3M-04021
6 x 1/2 x 1/2	3M-01025	3M-04021
6 x 1 x 1/2	3M-01031	3M-04021

SANDING DRUMS



These drums have 1/4" diameter shanks except SH-3B which has a 3/8" shank. The core expanding nut on the drum is on the shank side and there are projections on the opposite end.



PART NUMBER	DIA. X WIDTH (IN.)
SH-1A-SAND-DRUM	1 x 1
SH-1B-SAND-DRUM	1 x 2
SH-2A-SAND-DRUM	2 x 1
SH-2B-SAND-DRUM	2 x 2
SH-3B-SAND-DRUM	3 x 3 x 3/8

SANDING BANDS



PART NUMBER	DIA. X WIDTH (IN.)	GRIT
SB-2X1-36GR	2 x 1	36
SB-2X2-120GR	2 x 2	120
SB-2X2-24GR	2 x 2	24
SB-2X2-36GR	2 x 2	36
SB-2X2-60GR	2 x 2	60
SB-2X2-80GR	2 x 2	80

TOOLS

CROWN COIL SHAPER

Specifically designed to improve efficiency and save time. Eliminates pounding and wood stocks. Used on motors 1/4 HP to 15 HP. Shipping weight 3 lbs.



PART NUMBER	TC-2610
-------------	---------

WINDING HORN



This handy tool is carefully designed with the size and shape most winders need. It is exactly 12" long, made of highest quality bone fibre- 1/2" thick.

PART NUMBER	TLA-295
-------------	---------

CROWN WEDGE DRIVER

Prevents wedges from breaking or bulging while being driven into place. Outer shell is made from brass, driving pin made from steel. Shell length 6" overall 7".



TC-2211	1/32" X 3/8"
TC-2212	1/16" X 3/8"
TC-2213	3/32" X 5/8"
TC-2214	1/8" X 5/8"
TC-2215	3/16" X 5/8"
TC-2216	1/16" X 5/8"
TC-2217	1/8" X 7/8"

WINDING PADDLE

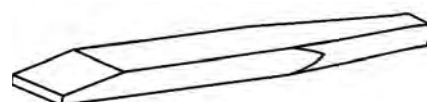

Winding paddle is made from high impact plastic and is 14" long.

PART NUMBER	TWP-678
-------------	---------

HANDLE TYPE COIL TAMPERS



Coil tampers mounted on a 19" handle. Pries or hammers coils into place. Spoon shaped end used to press end coils into place. Shipping wt. 12 oz.

TI-43-001HT	3/16" X 7/8"
TI-43-002HT	5/16" X 1 1/4"
TI-43-012HT	3/8" X 2"

LAYCOCK LACING HOOK



Greatly simplifies the job of taping, lacing or tying coil ends after installed in the stator. 5" handle with a 2" hook.

PART NUMBER	TLA-WH
-------------	--------

TOOLS

LAYCOCK LAMINATION TOOTH STRAIGHTENERS

Designed with a square end to permit the use of a socket or box end wrench to apply torque. The teardrop shaped blade adds strength and minimizes flexing when using full length tool. Available in three sizes to fit stator slots up to 150 HP.

Part Number: TLA-LTS Complete set of three sizes listed below.

Part Number: TLA-LTS-1 1/2" blade height, Wrench fitting 3/8" Square.

Part Number: TLA-LTS-2 5/8" blade height, Wrench fitting 1/2" Square.

Part Number: TLA-LTS-3 3/4" blade height, Wrench fitting 1/2" Square.



CABLE CUTTER

This cable cutter is designed to cut insulated copper or aluminum multi-strand cable or wire quickly and cleanly.



Features:

- Cuts copper or aluminum multi-strand cable or wire
- Precise one hand shearing action
- Patented "off-set bite" eliminates compression/frayed ends
- Heat treated high carbon steel shear edges
- Drop forge, heat treated frame
- Heavy vinyl handle safety covers

PART NUMBER TUP-B41

EPOXY SPRAY GUN

This specially designed gun permits easy spraying of unthinned Epoxylite 213 and Dolph CC-1081 when 80 to 100 PSI air pressure is available. Easy control is obtained with positive air valve permitting a puff or full blast at the operators choice. The gun is also useful for "solvent blasting" in cleaning operations.

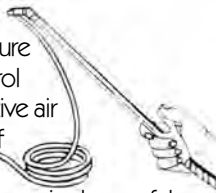

PART NUMBER TDSG-100

IDEAL HAND GRIP WIRE STRIPPER

Cuts and strips insulation, scrapes wire, straightens kinks and sharp bends. Hardened tool steel blade, removable for resharpening or replacement.



PART NUMBER TWS-45-021

COIL TAMPING PLIERS

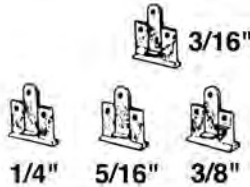
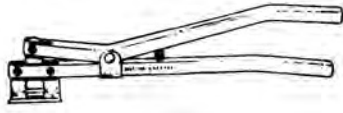

The perfect tool for tamping coils into slots. Does not damage insulation. Fits the smallest stators.

Part Number: NTP-100 Complete set pliers and four jaws.

Part Number: NTP-101 Pliers Only
Part Number: NTP-102 5/32" Jaws
Part Number: NTP-103 3/16" Jaws
Part Number: NTP-104 1/4" Jaws

COIL TAMPING TOOL



PART NUMBER	DESCRIPTION
TC-2201	3/16" X 7/8"
TC-2202	5/16" X 1-1/4"
TC-2203	3/8" X 2"
TC-2204-NO-HANDLE	3/8" X 4"

WIRE GAUGE

American standard for non ferrous metals. Gauges wire, sheets and plates of brass, copper and aluminum. Decimal equivalents stamped on backside. Range 0 to 36 gauge.

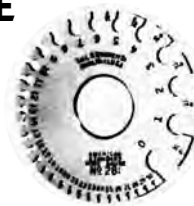

PART NUMBER TWSG-100

PRECISION VERNIER CALIPER 6"

For I.D., O.D., and depth measurements. Made from harden polished steel. Reads 1/1000 of an inch on lower scale and 1/20 mm on upper scale. Quicklock provides instant adjustment and accurate reading.



PART NUMBER TVC-100

CLAUSS SHEARS



General purpose shop shears for cutting wire, insulation, banding and hundreds of other uses.

PART NUMBER	DESCRIPTION
TSCR-4248	SHEARS;7.75";STRAIGHT
TSCR-4268	SHEARS;8.25";STRAIGHT
TSCR-4268-KBL	SHEARS;8.25"; KNIFE BLADES LEFT
TSCR-4877	SHEARS;LIGHT METAL;7"

IDEAL CONTINUITY TESTER

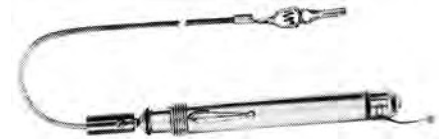

Pen-lite battery powered, tests dead circuits without live wire connections. Handy tester for checking continuity of dead circuits, grounds on conduit systems identifying wires in multi-wire cable. Unit is powered by two pen-lite batteries not supplied and gives light signal to indicate a complete circuit. Has a four foot removable cord equipped with alligator clips.

PART NUMBER TI-61-030

WEDGE REMOVER

Removes old wedges from armatures and stators. The coarse teeth ranging from 3/32" to 1/8" thickness from front to back, bite firmly into the wedge. The curved blade allows application of driving force at best possible angle.



PART NUMBER TWR-100

SLOT CLEANING BRUSH

This inexpensive slot cleaning brush can be one of the most useful tools in your shop. The brush diameter is 1/2", brush length 4", total length 15".



PART NUMBER TWB-1600

IDEAL STRIPMASTER®

AUTOMATIC SINGLE-SQUEEZE STRIPPER

The standard of the industry. An automatic hand stripper with knife-type blades for general purpose stripping of No. 8-26 AWG. Automatic features hold jaws open for removing wire without crushing end. Excellent for stripping of lighter gauge wires, automotive wiring, radio and instrument wire and cable, PVC hook-up wire, telephone or fixture wire. Net weight 14 oz.



PART NO.	WIRE SIZES	NO. OF HOLES	REPLACEMENT BLADE NO.*
TWS-45-090	B to 12	3	TWS-L-4419
TWS-45-091	10 to 18	4	TWS-L-4420
TWS-45-092	10 to 22	6	TWS-L-4421
TWS-45-097	16 to 26	6	TWS-L-994

*Sets Only

ISOL-EX WIRE STRIPPER

COMPACT - EASY TO OPERATE

Strips all types of insulated wires from size 6 to 23 AWG. Ideally suited for electric motor repair. Built-in variable speed control, can be plugged directly into wall outlet, needs no transformer. Stripping pressure of the knives is by centrifugal force. Thin wire-low speed. Thick wire-high speed. When stripping stranded and shielded wire, special cutting heads are needed. Knives are made of hard alloy steel. Tool size 6"L x 2" dia. Net weight 19 oz.



Part No. TWS-236 Wire Stripper.

Part No. TW-236RK Replacement Knives (3).

Part No. TW-236NC Replacement Nose Cone.

ERASER HAND HELD MAGNET WIRE STRIPPER

Ideally suited where the job cannot be taken to the machine. Strips both film and "glass" covered wires in square, rectangular or rounds up to 2 AWG. The wire stripping wheels counter-rotate for ease of operation. Distance between the wheels is easily adjusted by a locking thumb screw to adjust for wire sizes. Rated for intermittent duty.



POWER WIRE STRIPPER

This power stripper removes film and glass insulation from round wires - sizes 9 to 24 AWG. A big time saver, as the tool takes only a few seconds to strip each wire completely - ready for termination. Three counter balanced knives remove the insulation quickly. A 115V transformer governs the speed of the motor and the size of wire best stripped. Cleanly strip lengths up to 21/2" and to within 1/16" of any obstruction. Net weight 13 oz., net weight of transformer 4 lbs.



Part No. TWS-3 Wire Stripper and Transformer

IDEAL POWER STRIPMASTER

Pneumatic bench-type wire stripper based on the long-proven Stripmaster concepts for solid or stranded wire. Won't crush wire, fray ends, nick or cut wires. Adjustable wire guide lines up wire for proper stripping position. Variable sever length adjustment controls movement of severed insulation slug along wire from nil to 7/8". Slug may be left on wire for easy hand removal when ready for use. Features a wire gripper lock-out bar to provide blade-only operation for stripping fine gauge wires, so pulling wire out of stripper removes severed insulation on strip lengths longer than 7/8". Air pressure required: 30 to 120 psi. Standard unit comes with blade set No. L-4421 which strips general purpose wire sizes 10 to 22 AWG. Other blades available for 8 to 30 AWG, or order "special" die-type blades as required. Blades are easily interchangeable. Meets OSHA noise regulation level. Size: 3-9/16" x 12-5/16".



HANSCOM TIE CUTTER AND TIES

Cut your tying time in half! Hanscom Ties are the fast, sure way to bundle wires, coils, cords, etc. Just wrap them around the twist. Soft wire reinforcement makes them quick and easy to handle. Paper covered for one-time use or plastic where re-use is indicated. Buy by the spool - no waste - no fumbling for cut lengths when you use the cutters shown here. Hand Model-this convenient cutter screws to bench or wall. Measures, cuts, and dispenses a Hanscom-Tie in one quick easy motion. Takes only 8" x 16" space. Shipping weight 1 lb.

Part No. HTC-795 Manual Hand Model Tie Cutter. Lowest cost for temporary use and throwaway applications. Ideal for grouping parts and tying coils.

TIE WIRE PAPER TIES

THT-9018-*** Single wire 1/4" wide, 1500 foot spool. Paper-covered.

THT-9088-### Double wire 1/4" wide, 1500 foot spool. Paper-covered. Plastic Ties.

For permanent or repeat use. Ideal for wiring harnesses, securing lead wires, and tying coils.

THT-5025-BLU Single wire 1/4" wide, 3000 foot spool. PVC Plastic-covered. Blue color

*** Colors Black = BLK, Blue = BLU, RED, White = WHT

Colors Black = BLK, Blue = BLU, RED, White = WHT, Yellow = YEL

IDEAL TWIN WHEEL PRODUCTION STRIPPER

Production bench stripper quickly removes all types of film insulation, sizes 8 through 47 and rectangular up to 3/16" thick.

Telescoping screw adjustment for precision stripping. Strips any length wire to within 3/4" of body of winding. General purpose stripping with twin fiberglass wheels L-6063 as standard. 13" long, 6-1/4" wide, 8-3/4" high. Motor 115V, AC, HP, Brush Speed 5000 RPM.

Part No. TWS-45-159 Weight 22/lbs.

REPLACEMENT BRUSHES - I Face Width

Part No. TWS-L-O63 General Purpose Fiberglass Brush.

Part No. TWS-L-3011 General Purpose Wire Brush.

Part No. TWS-L-3012 H.D. for Fabric & Enamel/Wire Brush.



ERASER DCFR MAGNET WIRE STRIPPER

A new hand-held wire stripper, designed for removing insulation from flat, rectangular, and square magnet, enamel and film insulation wires. Will strip most insulation types, including glass, varnish, epoxy and polythermalize from wires of sizes up to 5/8" x 3/4" in cross section. The unit incorporates a high speed rotating stripping head, with custom designed cutting flutes for quick insulation removal. The tool strips cleanly and quickly with no bouncing or jerking. Unlimited strip lengths are possible at any point on a wire, and it is an ideal tool for producing mechanical taps in the manufacture of transformers and other coils. Operates from a low voltage DC variable speed control unit, the handpiece weighs 17 ounces and is 7" long x 27A6" in diameter.



TOOLS

MUELLER CLIPS

The most complete line of alligator, test, miniature, battery and special purpose clips available. Well designed and universally used for quick, temporary electrical connections. A size and shape for even the most unique application.

NOTE: All clips with part number ending with C are solid copper. All clips with part number ending with A are steel-lead plated. All other clips are steel-cadmium plated. Unless otherwise stated: All items are sold in minimum quantities of 10. Insulators sold separately.

"60 SERIES" ALLIGATOR CLIPS

New slim design with full-meshing teeth. Round thumb grip, barrel connection for banana plug.



- Part No. MUC-60** Steel - Plain - 2"L, Spread 5/16".
- Part No. MUC-60S** Steel - Screw - 2"L, Spread 5/16".
- Part No. MUC-60CS** Copper - Screw - 2"L, Spread 5/16".
- Part No. MUC-BOHS** Steel - Screw - Insulated Barrel 2" L, Spread 5/16"
- Part No. MUC-62** Flexible Vinyl Insulator (5 Red - 5 Black).
- Part No. MUC-63C** Copper - Completely Insulated - Screw - 2 1/8" L, Spread 1/4"

"70 SERIES" ALLIGATOR CLIPS

A trim, modern clip with wire crimping ears.



- Part No. MUC-70** Steel - Plain 1 11/16"L, Spread 5/16".
- Part No. MUC-70CX** Copper - Screw 1 11/16"L, Spread 5/16".

"PEE-WEE" CLIPS

A very small clip for general test purposes. Jaw teeth mesh. Interlocking neck prevents jaw offset.



- Part No. MUC-45** Steel - Screw 1 1/2" L, Spread 5/16"
- Part No. MUC-47** Flexible Vinyl Insulator (5 Red - 5 Black).

GENERAL PURPOSE TEST CLIPS

Sharp needle in one jaw, pierces insulation of wire to make immediate electrical contact.



- Part No. MUC-50C** Copper - Brass Screw 2 1/4" L, Spread 1/2".
- Part No. MUC-49** Flexible Vinyl Insulator (5 Red - 5 Black).

A high-grade test clip with meshing teeth on all three sides of jaw.

- Part No. MUC-27** Steel - Screw 2 7/16"L, Spread 5/8".
- Part No. MUC-27C** Copper - Screw 2 7/16"L, Spread 5/8".
- Part No. MUC-29**** Flexible Vinyl Insulator (Black, Blue, Green, Red).



HEAVY DUTY TEST CLIPS

25 and 50 Amp Capacity sizes for battery operated equipment and test work. Teeth on one jaw and notch on other. Interlocking necks prevent jaw offset. Packed half marked +, half-plain. Steel (lead plated). Screw - with locking ears.



- Part No. MUC-21A** 50 Amp Capacity, 4"L, Spread 1 2 7/8"
- Part No. MUC-24A** 25 Amp Capacity, 2 7/8"L, Spread 3/4".

75 Amp Capacity. A rugged new clip for meter and miscellaneous test work requiring high current. Teeth mesh on all three sides of jaw.

- Part No. MUC-25C** Copper - Screw 3" L, Spread 3/4"



100 Amp Capacity clip for battery chargers, booster cables, discharge tests and general testing. Lead coated copper shunt protects spring. Lead coated copper lug for cable attachment. Marked either + or plain, sold individually.

- Part No. MUC-11A** Steel (lead plated) 6"L, Spread 15/8".



100 and 200 Amp Capacity sizes for general testing, battery work and grounding. Equipped with removable copper lug for cable attachment. Copper shunt protects spring, minimizes heating on overload. Interlocking necks prevent jaw offset. Marked either + or plain, sold individually.

- Part No. MUC-21C** 100 Amp Copper 4 1/2"L, Spread 1 1/16".

- Part No. MUG-11C** 200 Amp Copper 6"L, Spread 1 5/8".



Big Brute clip 300 Amp Capacity. The largest in the line. Recommended and widely used as a welding ground clamp, heavy duty test work, grounding gasoline trucks and on thawing machines. Removable copper lug for cable attachment. Copper shunt protects spring and minimizes heating on overload. Interlocking neck. Sold individually.

- Part No. MUC-33C** Copper 7 3/4"L, Spread 2 1/4".



VINYL INSULATORS

- Part No. MUC-26** Flexible Vinyl Insulator for Test Clips MUC-24A and MUC-25C (5 Red - 5 Black).
- Part No. MUC-23** Flexible Vinyl Insulator for Test Clips MUC-21 A and MUC-21C (5 Red - 5 Black).
- Part No. MUC-13** Flexible Vinyl Insulator for Test Clips MUC11A and MUC11C (5 Red - 5 Black).

STANLEY COMPO-CAST® HAMMERS

The most versatile, durable, all-purpose hammer available. As thorough as it is gentle. The entire exterior surface is solid molded urethane, virtually indestructible. Outlasts rawhide, nylon, rubber, brass or lead by 10 to 20 times. All models feature dead blow heads for sustained impact and maximum striking force. Wrap around grip with flanged butt. No Mark - No Spark.



STANDARD MODELS				
PART NUMBER	FACE DIA.(IN.)	HEAD LENGTH(IN.)	LENGTH (IN.)	WEIGHT
TCH-OHD	1 1/2	3 1/8	10	14 oz.
TCH-IHD	1 3/4	3 3/4	11	1 1/2 lbs.
TCH-2HD	2	4 1/4	12 3/4	2lbs.
TCH-3HD	2 1/2	4 3/4	14	3lbs.
TCH-4HD	2 3/4	5 1/4	16	4 lbs.

SLIMLINE MODELS				
PART NUMBER	FACE DIA.(IN.)	HEAD LENGTH(IN.)	LENGTH (IN.)	WEIGHT
TCH-O-XHD	1	3	9 1/2	8 ozs.
TCH-X02-HD	1 1/4	4 1/4	10 1/2	11 1/2 lbs.
TCH-X03-HD	1 1/2	4 1/4	12	11 1/2 lbs.
TCH-XI-HD	1 3/4	5 1/4	13	2 lbs.
SLEDGE MODELS				
TCH-4HD-1	2 3/4	7	20	7 lbs.
TCH-12HD	3 1/2	8	30	12 lbs.
TCH-14HD	3 1/2	8	36	14 lbs.

GARLAND RAW HIDE HAMMER

Tough, resilient water buffalo hide faces deliver



cushioned power to protect fine finishes and delicate parts. Faces locked in malleable iron jaws - cannot fly off, but replaceable in seconds by removing threaded nut. Extra long, flare-grip handle for greater striking power, safety and long life. Faces fit all types and makes of standard hide-face hammers.

PART NUMBER	WEIGHT	FACE DIAMETER (IN.)	EXTRA FACES PART NUMBER
TRH-1	1 1/2 lbs.	1 1/4	TRH-0-F
TRH-2	2 lbs.	1 1/2	TRH-1-F
TRH-3	2 3/4 lbs.	1 3/4	TRH-2-F
TRH-4	4 lbs.	2	TRH-3-F
TRF-5	6 1/2 lbs.	2 3/4	TRH-4-F
			TRH-5-F

MARTINDALE AIR GRINDER

Use with carbide rotary burrs. The kit includes a high speed precision manufactured air grinder and five 2 1/4" long solid carbide 1/4" diameter rotary burrs (burrs include RB4, RC4, RD4, RH4 and RJ4). Lightweight (1 lb. 6 oz.) and high speed (21,000 RPM). Recommended air pressure 70-90 PSI, air inlet is 1/4" female N.P.T.F. Burrs - 6 inches long Tungsten carbide burrs.



Part Number: TAG-38A kit with 5 burrs

Part Number: TAG-M12 Grinder only

Part Number: TAG-128221-700

Filter/Lubricator

Part Number

TAG-RB4-6



TAG-RC4-6



TAG-RD4-6



TAG-RH4-6



TAG-RJ4-6



POW'R BLO AIR HAMMERS

SPECIFICALLY DESIGNED FOR MOTOR STRIPPING

One piece barrel - machined from finest tool steel - properly hardened and tempered. Two piece - patented main valve - made of shock steel precision ground, hardened and tempered. 3500 strokes per minutes. Air requirement - 4 cubic feet per minute at 80 to 150 psi.

Part No. TPH-171 Safety Tool Holder - It's practically impossible for a tool to fly out of the hammer. Chisels cannot stick in the works due to the tool holder. Replacement parts or fast factory repair available. Separate oiling access for easy care and maintenance.

Part No. TPH-25 Pow'r Blo Heavy Duty Hammer complete with pressure regulator and safety tool holder. Shipping weight 8 lbs. **Part No. TPH-75** Pow'r Blo Heavy Duty Hammer complete with pressure regulator, a complete set of stripping chisels, and safety tool holders.

ACCESSORIES

Part No. TPH-171 Safety Tool Holder for Pow'r Blo Hammer.

Part No. TPH-305U Tool Holding Spring for Pow'r Blo Hammer.

Part No. TPH-1VE 1/4" wide Parker Taper Shank Chisel.

Part No. TPH-20F 3/4" wide offset Flat Edge Chisel.

Part No. TPH-3CE Curved Edge Parker Taper Shank Chisel.

Part No. TPH-4CE 2A" wide Curved Edge Chisel.

Part No. TPH-55T 1 1/4" Saw Tooth Edge Chisel.

Part No. TPH-2350 Complete set of 5 Pow'r Blo Chisels.

BLUE DART AIR GUN

A deluxe air gun that delivers maximum power to move debris, chips and dust quickly and efficiently. It also meets OSHA regulations with new vented nozzle. Nozzle tips delivers 150 PSI.



PART NUMBER TPH-001

AIR GRINDER

Heavy duty straight air grinder for the best economy is equipped with a Jacobs three jaw chuck. Chuck key is included. 16,000 to 16,000 RPM no load speed 1/4" collect size.

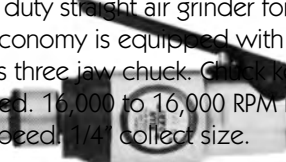

PART NUMBER TPH-211



Parker Taper Shank Chisels

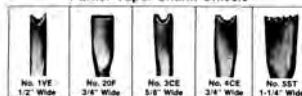

CROWN HEAVY DUTY AIR HAMMER



For high speed coil stripping. Features a universal spring retainer. Operator can easily rotate the cutting tool while operating hammer. The hammer may also be used for cutting panels, rivets, bolts, removing drum lids, and setting 1/4" soft iron and aluminum rivets. Delivers 3,500 blows per minute; uses only 4 cubic feet of air per minute at 80 to 150 psi.

Part No. TC-2707 Air Hammer

Shipping weight 4 lbs.

Part No. TC-2742 Combination Air Hammer and set of 3 chisels. Shipping weight 6 lbs.

COIL STRIPPING CHISELS

Part No. TC-2622 1/4" blade width Stripping Chisel

Part No. TC-2623 5/8" blade width Stripping Chisel

Part No. TC-2624 3/4" blade width Stripping Chisel

Part No. TC-2620 Set of 3 Stripping Chisels listed above

AIR HAMMER CHISELS



Part No. TC-2632 1/2" blade width Air Hammer Shank

Part No. TC-2633 5/8" blade width Air Hammer Shank

Part No. TC-2634 3/4" blade width Air Hammer Shank

The crescent eliminates ragged edges and prevents gouging of stators

Part No. TC-2630 Set of 3 Air Hammer Shanks listed above. Available in sets of three different sizes (i.e. 1/2", 5/8", 3/4") Individually or with Parker-Taper Shank.

TOOLS



ENDLESS TYPE V

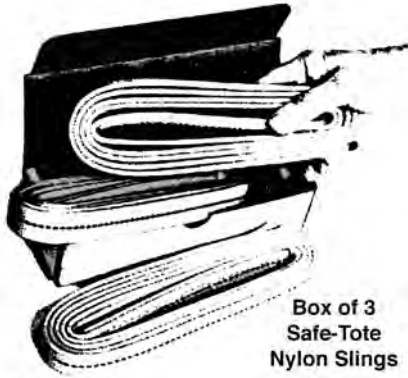

Box of 3 Safe-Tote Nylon Slings

CONVENIENT BOX OF 3 SLINGS OFFERS SAVINGS

3 Safe-Tote Endless nylon slings packaged in a convenient flip-top box offer extra savings. Choker at 30° has a 1 ton capacity. Basket at 900 has a 2 ton capacity.

IDEAL WIRE NUTS

Wire Nuts



PART NO.	SIZE	WIRE SIZES
TWN-30-071	71B	No.16 and No.18 up to 3 No.18 - 1 No.16 and 1 No.18.
TWN-30-072	728	No.14,16 and 18 AWG up to 1 No.14 and 1 No.18 - 2, 3, or 4 No.18.
TWN-30-073	738	No.14,16 and 18 AWG up to 2 No.14 and 1 No.18 or 5 No.18.
TWN-30-074	748	No.12,14,16 and 18 AWO up to 2 No.12 and 1 No.18 - 4 No.14 and 1 No.18.
TWN-30-076	76B	No.10,12,14, 16 and 18 AWG up to 3 No.10 with 1 No.18 - 4 No.12 with 2 No.18 - 6 No.14 with 2 No.18.

Solderless, tapeless wire connectors that are UL approved. Just strip wire and screw on. Threads on to wire like a nut on a bolt. Coil shaped spring insert presses (does not cut) clean threads into stripped wires as connector is applied. Wires are tightly compressed, twisted together. Molded composition shell completely protects against shorts, grounds, and corrosion. Sizes 74B and 76B approved as 600 volt pressure cable connectors for general use. Other sizes approved for 300 volt use. Standard packages of 100 only in each size.

KEYS

Part No. TJC-1 4-1 For Chuck 1/4" -3/8" TJC-1 2-38 For Chuck 1/2"



KEY HOLDERS

Part No. TJC-A Fig. B, Fits All
Part No. TJC-B Fig. C, Fits 1/4"
Part No. TJC-C Fig. C, Fits 3/8-1/2"

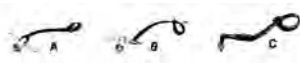

WEAR FLEX+ NYLON SLINGS

The endless sling is the strongest, most efficient and economical sling for all purpose lifting. It can be used in a basket, choker or a vertical hitch.

In a basket hitch the legs can be spread for added load stability. Load contact points change with every lift, increasing sling life and safety.

PART NO.	WIDTH (IN.)	CAPACITY	
		CHOKER AT 300	BASKET AT 900
EN-1001-*	1	1 Ton	2 Ton
EN-1002-*	2	2 Ton	4 Ton
EN-1003-*	3	3 Ton	6 Ton
EN-1004-*	4	4 Ton	8 Ton
EN-1006-*	6	6 Ton	12 Ton
EN-2001-*	1	2 Ton	4 Ton
EN-2002-*	2	4 Ton	8 Ton
EN-2003-*	3	6 Ton	12 Ton

NOTE: Foot length must be specified when ordering (EN-1001-3). Slings are available from 3 to 18 feet. All slings are priced at a 3 foot base price. There is an adder per each additional foot of length ordered.

Part No. MARK-III Safe-Tote Slings 1"W x 30"L. Box of 3.

Part No. MARK-IV Safe-Tote Slings 1"W x 40"L. Box of 3.

Part No. MARK-V Safe-Tote Slings 1"W x 50"L. Box of 3.

ASSEMBLY TOTE PANS

Heavy duty 22 gauge steel pans with metal handles and slot for data and job card. Ideal for keeping parts together during motor disassembly or for storing bulky items on shelves.

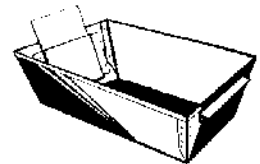

Dimensions 15 1/4"L, 10 5/16" W, 5 1/4"D.

PART NUMBER	TST-149
-------------	---------

DRILL CHUCKS FOR ELECTRIC DRILLS

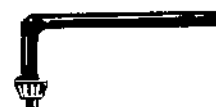
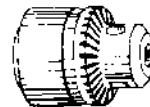

Part No. TJC-14 1/4" Drill Size, 1/4" Chuck Capacity, 3/8"-24 Thread.

Part No. TJC-38 3/8" Drill Size, 1/16-3/8" Chuck Capacity, Thread 3/8"-24

Part No. TJC-12 1/2" Drill Size, 5/64-1/2" Chuck Capacity, 1/2" - 20 Thread.

These famous make 1/4", 3/8" and 1/2" chucks are designed for "heavy duty" drilling and high accuracy. Hardened and ground alloy steel nut and jaw assembly guarantees long life. Complete with key.

COMMUTATOR SAWS

IDEAL COMMUTATOR SAWS

The "U" slot saw is available in 13 standard thicknesses from .015" to .045" With 12 different O.D. - I.D. combinations, there is a saw for almost every application. Special non-standard saws can be ordered. Specify thickness desired - minimum order 50 pieces.

Available in High Speed Steel or Tungston Carbide. Standard Thickness' available are .015, .018, .020, .023, .025, .028, .030, .032, .035, .038, .040, .043, .045. Special thickness' are available.



HIGH SPEED STEEL			
O.D. (IN.)	I.D. (IN.)	#TEETH	PART # PREFIX
1/4	1/8	14	10-HS-***
9/32	1/8	14	9-HS-***
5/16	1/8	16	9-1/2-HS-***
3/8	1/8	18	32-HS-***
3/8	3/16	18	33-HS-***
7/16	1/8	18	12-HS-***
1/2	3/16	18	16-HS-***
1/2	1/8	18	42-HS-***
11/16	3/16	28	13-HS-***
23/32	5/16	32	14-HS-***
3/4	1/4	22	64-HS-***
3/4	5/16	22	65-HS-***
7/8	9/32	24	3-HS-***
7/8	1/4	24	74-HS-***
7/8	5/16	24	75-HS-***
1	9/32	28	4-HS-***
1	1/4	28	84-HS-***
1	5/16	28	85-HS-***
1	3/8	28	86-HS-***
1-1/8	9/32	28	5-HS-***
1-1/8	3/8	28	96-HS-***
1-1/8	7/16	28	97-KHS-***
1-1/4	5/16	28	105-KHS-***
1-1/4	3/8	32	106-HS-***
1-1/4	1/2	32	108-KHS-***
1-1/4	9/32	32	6-HS-***
1-3/8	3/8	36	116-HS-***

TUNGSTON CARBIDE			
O.D. (IN.)	I.D. (IN.)	#TEETH	PART # PREFIX
1/4	1/8	12	10-TC-***
5/16	1/8	14	9-1/2-TC-***
3/8	1/8	14	32-TC-***
3/8	3/16	14	33-TC-***
7/16	1/8	14	12-TC-***
1/2	3/16	14	16-TC-***
1/2	1/8	14	42-TC-***
9/16	1/4	16	18-TC-***
5/8	1/4	16	54-TC-***
3/4	1/4	18	64-TC-***
3/4	5/16	18	65-TC-***
7/8	5/16	20	75-TC-***
7/8	3/8	20	76-TC-***
1	9/32	20	4-TC-***
1	5/16	20	85-TC-***
1	5/16	20	86-TC-***
1-1/8	9/32	22	5-TC-***
1-1/8	5/16	22	95-TC-***
1-1/8	3/8	22	96-TC-***
1-1/8	7/16	22	97-TC-***
1-1/4	5/16	24	105-TC-***
1-1/4	3/8	24	106-TC-***
1-1/4	1/2	24	108-TC-***
1-3/8	3/8	24	116-TC-***

*** Insert desired thickness to complete part number. I.E. 32-HS-032

IDEAL COMMUTATOR MILLING CUTTERS



The "V" slot milling cutters are made in one thickness only - .045. Because of the "V" shape of the teeth, this one thickness is suitable for cutting all thicknesses of mica ranging from .015" to .045". **Note:** All cutters, made of high speed steel, are intended for use in cutting commutator mica only. They are not recommended for slitting copper or other metals. All cutters are packaged in units of six each.

O.D. (IN.)	I.D. (IN.)	# TEETH	PART # PREFIX
1/2	3/16	12	17-VHS-**
1/2	1/8	12	42-VHS-**
11/16	3/16	14	13-VHS-**
23/32	5/16	14	15-VHS-**
3/4	1/4	14	64-VHS-**
3/4	5/16	14	65-VHS-**
7/8	9/32	18	3-VHS-**
7/8	1/4	18	74-VHS-**
7/8	5/16	18	75-VHS-**
1	9/32	22	4-VHS-**
1	1/4	22	84-VHS-**
1	5/16	22	85-VHS-**
1	3/8	22	86-VHS-**
1-1/8	9/32	24	5-VHS-**
1-1/8	3/8	24	96-VHS-**
1-1/8	7/16	24	97-KVHS-**
1-1/4	5/16	24	105-KVHS-**
1-1/4	3/8	24	106-VHS-**
1-1/4	1/2	24	108-KVHS-**
1-1/4	9/32	24	6-VHS-**
1-3/8	3/8	26	116-VHS-**

** Insert desired cutting angle to complete part number. i.e. 17-VHS-40

COMMUTATOR FILES AND SCRAPERS

Made especially to undercut mica and clean up commutator slots. 60° "V"-shaped slot

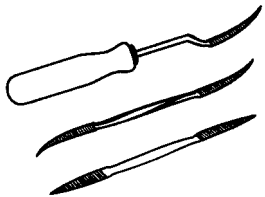

- Part No. TI-20-012** 7" Straight - Push Cut (A)
- Part No. TI-20-013** 7" Knife Edge - Push Cut (A)
- Part No. TI-20-007** 8" Curved - Draw Cut (B)
- Part No. TI-20-008** 7" Curved - Push Cut (B)
- Part No. TI-20-009** 9 1/4" Curved - Draw Cut (C)

IDEAL SLOTTER AND SCRAPER

Hand tool cleans slots, smooths burs, removes mica fins, bevels sharp copper edges after undercutting Rigid tool steel bit has "V" cutting edge at one end and "U" cuffer at other end. Length 6 1/2".

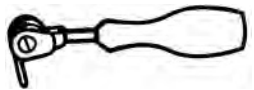

- Shipping weight 12 oz.
- Part No. TI-20-006** Slotter and Scraper.
- Part No. TI-L7704**

COMMUTATOR RESURFACERS

IDEAL COMMUTATOR RESURFACERS

Equipped with various style handles to meet conditions found in any type of commutator or slip ring. Used by simply holding resurfacer against commutator and moving it from side to side as motor turns over under its own power. Dimensions shown are length x width x thickness.

Code letters for different grade resurfacer are as follows:

X - Extra Coarse - Very fast cutting.

C - Coarse - Fast cutting.

M - Medium - For general use.

F - Finish - Used after above three grades.

P - Polish - For burnish finish (220 grain).

E - Extra Polish - For production finishing (320 Grain).

Code letters for combination grade resurfacer are as follows:

A - Medium/Finish

G - Coarse/Medium

B - Coarse/Finish

H - Medium/Polish

D - Finish/Polish

Note: Both Part No. and Grade No. must be specified when ordering, i.e. Part No.S80-155X.

PENCIL TYPE

For fans signal motors auto generators and other fractional HP motors.

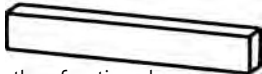

5/8" X 3/8" X 6" Grades X-C-M-F-P-E
Part Number S-80-075* * Add grade

BLOCK HANDLE TYPES

For use with precision grinder or lathe type



truing. Equipped with wood black handles Available in Grades X-C-M-F-P.

Part No. S-80-454* 1" x 1-1/2" x 5"

Part No. S-80-461* 1" x 2" x 5"

Part No. S-80-468* 1" x 2-1/2" x 5"

Part No. S-80-482* 1" x 1-1/2" x 8"

Part No. S-80-475* 2" x 2" x 5"

Part No. S-80-489* 1-1/2" x 2-1/2" x 8"

Part No. S-80-496* 2" x 2" x 8"

* Add grade

DOUBLE SAW HANDLE TYPES

For use on large rotary converters, engine driven generators and motors. Provides two hand controls. Available in Grades X-C-M-F-P.



Part No. S-80-407* 4"x8"x3"

Part No. S-80-419* 5"x7"x3"

Part No. S-80-432* 5"x9"x3"

STRAIGHT HANDLE TYPES

Used primarily on inaccessible commutators in small-enclosed motors Available in grades

X-C-M-F-P.

Part No. S-80-155* 1"x1"x1"

Part No. S-80-165* 1"x1"x2"

Part No. S-80-184* 2"x1"x2"

Part No. S-80-193* 3"x1"x2"

* Add grade

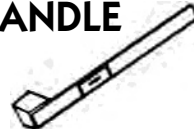

SMALL MOTOR TYPE

Medium grade stone on one side and a finish devi other end o

Available in

Grades

A-B-D-G-H

3/4"x1/2" x3/8"

Part No. S-80-12*

* Add grade



SAW HANDLE TYPE

For use on large motors, small rotary converters, motor generator sets, and telephone generators. Available in grades X-C-M-F-P.

Part No. S-80-362* 4"x3"x2"

* Add grade



VERTICAL ADJUSTABLE HANDLE TYPES

10" rod handle adjusts to three positions for medium sized motors and small generators.

Available in Grades X-C-M-F-P.

Part No. S-80-215* 2"x2"x2"

Part No. S-80-224* 3"x2"x2"

Part No. S-80-234* 3"x3"x2"

Part No. S-80-243* 4"x3"x2"

* Add grade

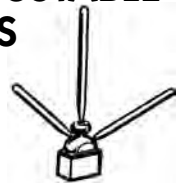

POCKET TYPES

Handy 2-in-1 utility tool available in all two-grade combinations. For use on small fractional HP motors and generators.

Available in Grades

A-B-D-G-H

Part No. S-80-112* 2"x1" x6"

Part No. S-80-137* 2"x1" x8"

*Add grade

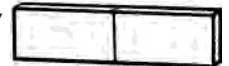

COMMUTATOR CEMENT

Non-conductor for filling holes in commutator bars, pitted mica. Strong, non-shrinking, resists fire, oils, and acids.

Part No. TI-54-007



IDEAL BRUSH SEATORS - COMMUTATOR CLEANERS

This gentle acting abrasive is very effective for seating carbon brushes and cleaning Commutators and Slip Rings. It is made of soft, loosely bound grain that produces a scouring effect as it is held against the commutator.

The abrasive wears away sufficiently for cleaning, but does not remove or scratch the copper. It is often called a "chalk" store because of its white color and chalk-like texture.



PART NUMBER	SIZE (IN.)	GRADES	NUMBER/PER BOX	PART NUMBER	SIZE	GRADES	NUMBER/PER BOX
TI-23-001	1/4x1/4x4 3/4	M-H	12	TI-23-027	1 1/2x1x4 3/4	S-M-H	1
TI-23-002	1/2x1/4x4 3/4	M-H	6	TI-23-035	1x1x4 3/4	S	4
TI-23-003	3/8x3/8x4 3/4	M-H	4	TI-23-036	2x1x4 3/4	S	2
TI-23-004	1/2x3/8x4 3/4	S-M-H	4	TI-23-037	2x2x2	S	2
TI-23-005	1/2x1/2x4 3/4	S-M-H	2	TI-23-039	3x2x4	S	2
TI-23-006	5/8x1/2x4 3/4	S-M-H	2	TI-23-041	3x2x6	S	2
TI-23-007	3/4x1/2x4 3/4	S-M-H	2	TI-23-042	3x2x8	S	2
TI-23-008	1 1/8x5/8x4 3/4	SM-H	1				

IDEAL COMMUTATOR SMOOTHIE®



A resurfacing tool designed to smooth commutators of auto generators, starting motors and other similar equipment. Consists of an 8-1/2" plastic handle with a 5/16" x 7/8" x 1 1/16" resurfacer on each end. One resurfacer is polish grade and the other is finish grade. Handle is properly bent to reach not any motor frame. Both the resurfacing material and handle are non-conducting. Part No. S-80-033

HAND TOOLS & SHOP SUPPLIES

PORTABLE HYDRAULIC PULLEY PULLER

Portable and easy to operate, it quickly removes practically any object from a shaft. Sturdily constructed yet reasonably priced, it has added safety features like remote control and Quicklink Chain Attachment. Pressure is supplied to the hydraulic ram by either an easily operated hand pump or an electrically operated pump. Three simple adjustments set the puller to the dimensions required. The beam, arms, ram and pump can be removed from the puller stand for overhead or other special uses. Eliminates the need for crow bars, wedges, torches, etc.

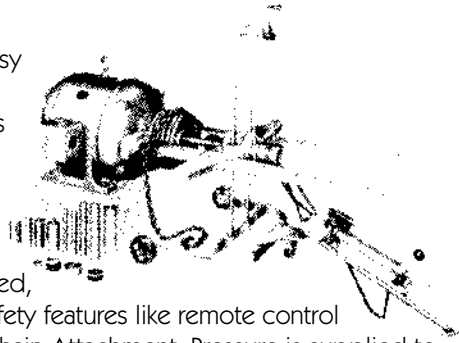

SPECIFICATIONS						
MAXIMUM PULLER	MAXIMUM DIAMETER (IN.)	DIMENSIONS FACE (IN.)	H(IN.)	SHIP W(IN.)	L(IN.)	WEIGHT
8 Ton	22	24	40	26	36	140 lbs.
20 Ton	32	36	42	34	48	460 lbs.
60 Ton	42	48	48	46	60	820 lbs.
100 Ton	48	48	48	46	60	1060 lbs.

KUKKO UNIVERSAL BEARING EXTRACTORS NO. 21 AND 22

The ideal tool for removing ball bearings, ball races, sleeves, or bushes.

The excellent gripping effect ensures safe hold and easy extraction of the bearings, even if the bearing fits very closely to the rear of its housing.

Method of Operation

Insert the internal extractor No. 21 into the bore of the ball bearing. Tightening the nut B causes jaws C to expand and lips D to be pressed behind the rounded edges of the bearing race.

The counter Stay No. 22 is placed on the housing and spindle E screwed onto the Spindle A of the internal extractor.

Now handle G is held firmly and nut F on the counter stay is tightened, thus effecting extracting action.

During extraction retighten nut B on the internal extractor.

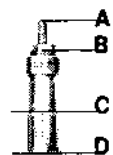

No. 21



No. 22
removable threaded reduction collar



Part No. THP-8H 8 Ton Manual Hydraulic Puller complete with Quicklink Chain Attachment.

Part No. THP-20H 20 Ton Manual Hydraulic Puller with Quicklink Chain Attachment and set of Ram Adapters.

Part No. THP-60H 60 Ton Manual Hydraulic Puller with Quicklink Chain Attachment and set of Ram Adapters.

Part No. THP-20HEP 20 Ton Hydraulic Puller with Electric Pump, with Quicklink Chain Attachment and set of Ram Adapters.

Part No. THP-60HEP 60 Ton Hydraulic Puller with Electric Pump, with Quicklink Chain Attachment and set of Ram Adapters.

Part No. THP-100HEP 100 Ton Hydraulic Puller with Electric Pump, with Quicklink Chain Attachment and set of Ram Adapters.

ACCESSORIES

Part No. THP-80 Quicklink Chain for 8 ton model. 6' of 3/8" chain.

Part No. THP-200 Quicklink Chain for 20 ton models. 8' of 3/8" chain.

Part No. THP-600 Quicklink Chain for 60 ton models. 10' of 1/2" chain.

Part No. THP-2OEPK 20 Ton Electric Pump Kit. *

Part No. THP-6OEPK 60 Ton Electric Pump Kit. *

Part No. THP-RA-20 Set of 10 Adapters for 20 ton models.

Part No. THP-RA-60 Set of 10 Adapters for 60 ton models.

Part No. THP-RA-100 Set of 10 Adapters for 100 ton models.

*The electric pump is wired for 115V/10/60 Hz. This pump is available in easy-to-install kit form for adaptation to all 20, 50 and 60 ton pullers manufactured since 1945.

FOB DAVENPORT, IOWA

INTERNAL EXTRACTORS NO. 21/0-21/9			
PART NUMBER	INCHES	MM	WEIGHT
TGP-21/0	13/64 - 15/64	5 - 6	3 oz.
TGP-21/00	15/64 - 5/16	6 - 8	3 oz.
TGP-21/01	5/16-13/32	8 - 10	3 oz.
TGP-21/02	13/32 - 1/2	10 - 12	3 oz.
TGP-21/1	1/2 - 9/16	12 - 14.5	4 oz.
TGP-21/2	9/16- 23/32	14.5 - 18.5	4 oz.
TGP-21/3	23/32 - 29/32	18.5 - 23.5	8 oz.
TGP-21/4	29/32 - 1 3/16	23.5 - 30	9 oz.
TGP-21/5	1 3/16-1 15/32	30 - 37	14 oz.
TGP-21/6	1 15/32 - 1 13/16	37 - 46	1 1/2 lbs.
TGP-21/7	1 13/16 - 2 7/32	46 - 56	2 3/4 lbs.
TGP-21/6	2 7/32 - 2 3/4	56 - 70	3 1/4 lbs.
TGP-21/9	2 3/4 - 3 15/16	70 - 100	6 lbs.

Counter Stays No. 22/1-22/3 for use with internal extractors No. 21/0-21/9

PART NO. SUITABLE FOR NO. CONNECTION TO INTERNAL EXTRACTOR* WEIGHT LBS.

TGP-22/1	21/01-21/5	21/0-2 with reduction collar	
		21/3-5 without reduction collar	1 1/2
TGP-22/2	21/3-21/8	21/3-5 with reduction collar	
		21/6-8 without reduction collar	3
TGP-22/3	21/9	By connecting nut	7 1/2

*The counter stays No.22/1 and 22/2 are each supplied with a threaded reduction collar; application in accordance with the above table.

The Complete Puller consists of internal extractor No. 21 and counter stay No. 22

HAND TOOLS & SHOP SUPPLIES

KUKKO BALL BEARING EXTRACTOR & PULLERS

NO. 11 THREE ARM PULLERS

A well tried industrial puller for removing large pulleys, gear wheels, and similar heavy components. For internal and external operation. Extremely strong pulling arms have large contact surfaces so that careful removal without damage is accomplished. Longer arms to 20" depth are available.

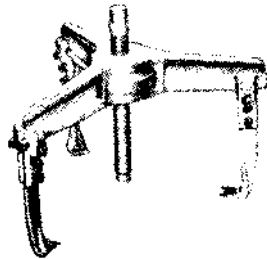

- Part No. TGP-11/0-A** 15" Capacity with 8" Gripping Depth. Shipping Weight approx. 30 lbs.
- Part No. TGP-11/1-A** 21" Capacity with 8" Gripping Depth. Shipping Weight approx. 48 lbs.
- Part No. TGP-11/2-A** 26" Capacity with 8" Gripping Depth. Shipping Weight approx. 59 lbs.

NO. 12 THREE ARM PULLERS

Sturdy pullers with excellent gripping action for removing ball bearings, gear wheels, and pulleys. The slender arms enable this puller to be used in places which are not easily accessible. The wrench fixes the arms to the required width in such a way so as to prevent the arms slipping off.

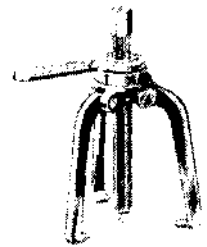

- Part No. TGP-12/1** 3 1/8" Capacity with 3 1/8" Gripping Depth. Shipping weight approximately 2 1/2 lbs.
- Part No. TGP-12/2** 4 3/8" Capacity with 5" Gripping Depth. Shipping weight approximately 4 lbs.
- Part No. TGP-12/3** 8" Capacity with 6 1/2" Gripping Depth. Shipping weight approximately 7 lbs.

NO. 20 TWO ARM PULLERS

Well constructed, sturdy puller with large pulling surfaces and extra thin claws for use in restricted position. For both internal and external pulling. Longer arms to 20" depth are available.

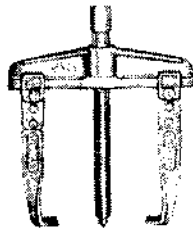

- Part No. TGP-20/1** 3" Capacity with 4" Gripping Depth. Shipping weight approximately 2 lbs.
- Part No. TGP-20/10** 5" Capacity with 4" Gripping Depth. Shipping weight approximately 2 1/2 lbs.

- Part No. TGP-20/2** 6" Capacity with 6" Gripping Depth. Shipping weight approximately 6 lbs.
- Part No. TGP-20/20** 8" Capacity with 6" Gripping Depth. Shipping weight approximately 7 1/4 lbs.
- Part No. TGP-20/3** 10" Capacity with 8" Gripping Depth. Shipping weight approximately 15 lbs.
- Part No. TGP-20/30** 14" Capacity with 8" Gripping Depth. Shipping weight approximately 19 lbs.
- Part No. TGP-20/4** 21" Capacity with 8" Gripping Depth. Shipping weight approximately 28 lbs.
- Part No. TGP-20/5** 30" Capacity with 16" to 27" Gripping Depth. Shipping weight approximately 90 lbs.

NO. 205 & 206 PULLERS

Very powerful pullers for pulling gears and pulleys. Adjustable fixing of the arms secures correct fitting to the required gripping depth. Arms automatically tighten when nut is turned.

TWO ARM PULLERS



205

- Part No. TGP-205/01** 6" Capacity with 6" Gripping Depth. Shipping weight approximately 2 lbs
- Part No. TGP-205/02** 8 3/4" Capacity with 8 3/4" Gripping Depth. Shipping weight approximately 5 lbs.
- Part No. TGP-205/1** 12" Capacity with 9 1/2" Gripping Depth. Shipping weight approximately 12 lbs.
- Part No. TGP-205/2** 14" Capacity with 16" Gripping Depth. Shipping weight approximately 15 lbs.

THREE ARM PULLERS



206

- Part No. TGP-206/01** 6" Capacity with 6" Gripping Depth. Shipping weight approximately 3 lbs.
- Part No. TGP-206/02** 8 3/4" Capacity with 8 3/4" Gripping Depth. Shipping weight approximately 7 lbs.
- Part No. TGP-206/1** 12" Capacity with 9 1/2" Gripping Depth. Shipping Weight approx. 15 lbs.
- Part No. TGP-206/2** 14" Capacity with 16" Gripping Depth. Shipping Weight approx. 20 lbs.

NO. 41 & 42 PULLERS

Useful models for removing battery terminals and other light puller jobs.



- Part No. TGP-41** Two Arm Puller 2 9/16" Capacity with 2 9/16" Gripping Depth. Shipping weight approximately 5 oz.
- Part No. TGP-42** Three Arm Puller 2 9/16" Capacity with 2 9/16" Gripping Depth. Shipping weight approximately 9 oz.

BALL BEARING INSTALLER KIT

Installs ball bearings fast and easy without damage to seals or flanges. Sleeves are made of steel, heat treated and hardened for use with arbor press or mallet, admium plated for protection against rust, and knurled for easy handling. Sleeve made about .025" larger than bore of bearing, and passes easily over shaft, providing a perfectly lined installation. Outside diameter fits inner race of bearing. Long enough to use on standard NEMA shaft extension. Ranges from 200 Series ball bearings (10mm I.D.) to 209 Series (45mm I.D.)

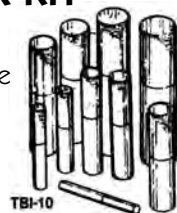

TBI-10

- Part No. TBI-10** Set of 10 sleeves for bearings 10 to 45mm bore.

HAND TOOLS & SHOP SUPPLIES

KUKKO HYDRAULIC RAM & SEPARATORS

NO. 9 HYDRAULIC RAM



Part No. TGP-9/1 10 Ton Capacity, 1-1/2"D x 2-9/16"H. Shipping weight 2 lbs.

Part No. TGP-9/2 15 Ton Capacity 2"D x 3"H. Shipping weight 3-1/2 lbs.

Many Applications - Minimum space required.

This ram is a first class auxiliary tool to increase the operating power of mechanical pullers when in use on stubborn pulling jobs.

Method of Operation:

Position the ram with fully unscrewed side pressure spindle between shaft and puller thrust bolt and secure by tightening the puller thrust bolt.

Hydraulic operation is obtained by screwing in the side pressure spindle. If first application is insufficient to complete pulling operation, continue the pulling performance with the puller thrust bolt, or proceed as follows: screw-back spindle, fully retighten thrust bolt screw in spindle again. **Important:** After use, unscrew spindle whereby the built-in return spring resets the thrust bolt to its starting position.

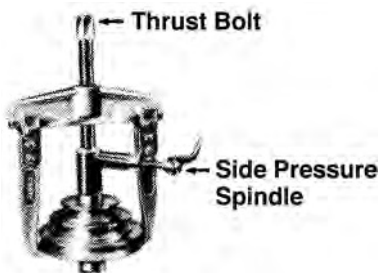

BALL BEARING PULLER ADAPTERS



Where bearings are recessed and cannot be held by the separator, a specially designed set of Puller Adapters has been engineered. The carefully machined high-grade steel adapters can be slipped on the bearing in seconds; the adapter ring is then set to contain the bearing. The Adapter, with the bearing enclosed, is set into the separator holder for efficient removal of the bearing. The Ball Bearing Puller Adapters are made in the following 6 sizes.

NO. 15 SEPARATORS

Part No. TGP-15/0 Weight 1-1/2 lbs. A-1/4" to 3-3/8", B-2-3/8".

Part No. TGP-15/1 Weight 2 lbs. A-1/2" to 3", B-3".

Part No. TGP-15/2 Weight 5 lbs. A-7/8" to 4-1/2", B- 4-1/2".

Part No. TGP-15-3 Weight 10 lbs. A-1-1/4" to 6-1/8", B-6-1/8".

Part No. TGP-15/4 Weight 24 lbs. A-1-1/4" to 7-7/8", B-7-7/8".

Part No. TGP-15/5 Weight 35 lbs. A-1-1/4" to 9-7/8", B-9-7/8".

Separator jaws are tightened by equally tightening nuts on the side bolts. Each separator has a minimum and maximum spread between jaws (A dimension). Choose proper separator for job requirements.

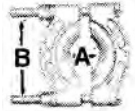

NO. 17 SEPARATORS

Part No. TGP-17/0 Weight 2 lbs. A-1/4" to 2-3/8", B-2-3/8".

Part No. TGP-17/1 Weight 3 lbs. A-1/2" to 3", B-3".

Part No. TGP-17/2 Weight 7 lbs. A-7/8" to 4-1/2", B-4-1/2".

Part No. TGP-17-3 Weight 10 lbs. A-1-1/4" to 6-1/8", B-6-1/8".

This design is very handy because the separator jaws are quickly and concentrically tightened by a central thrust screw. Each separator has a minimum between jaws.



NO. 135



Part No. TGP-135/1 Width of separator 23/32". Shipping weight approximately 1 1/2 lbs.

Part No. TGP-135/2 Width of separator 29/32". Shipping weight approximately 1 1/3 lbs.

Part No. TGP-135/3 Width of separator 1 1/16". Shipping weight approximately 2/ lbs.

Part No. TGP-135/4 Width of separator 1 7/32". Shipping weight approximately 2 3/4 lbs.

For removing bearings, pulleys, and sheaves especially in case of limited space. After positioning the tapered end, parts are separated by hammer blows.

Part No. TGP-202 Adapter fits all "202" series bearings, having 35mm diameter ie. 202-3202-6202.

Part No. TGP-203 Adapter fits all "203" series bearings, having 40mm diameter ie. 203-3203-6203.

Part No. TGP-204 Adapter fits all "204" series bearings, having 42mm diameter ie. 204-3204-6204.

Part No. TGP-205 Adapter fits all "205" series bearings, having 52mm diameter ie. 205-3205-6205.

Part No. TGP-305 Adapter fits all "305" series bearings, having 62mm diameter ie. 305-3305-6305.

Part No. TGP-306 Adapter fits all "306" series bearings, having 72mm diameter ie. 306-3306-6306.

HAND TOOLS & SHOP SUPPLIES

RECO INDUCTION BEARING HEATER

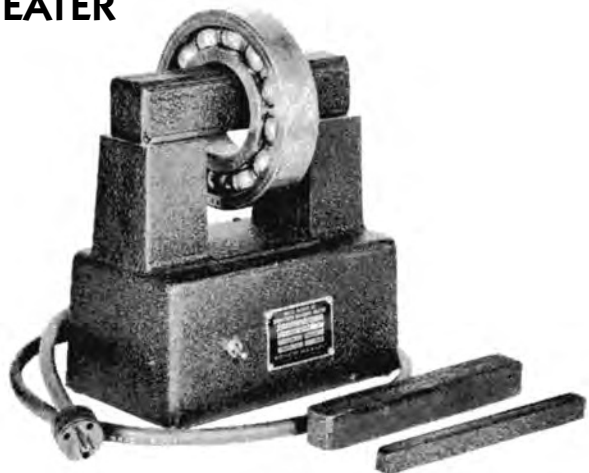

Part No. TRBH-805 Induction Bearing Heater. Includes set of 3 cross-bars listed in specs.

ACCESSORIES:

Part No. TRBH-10 Extra small bar used with 203 and 204 bearings size 1/2" x 1/2".

Part No. TST-213 Tempulstik Temperature Rating Marker. Rated at 213°F.

Part No. TRBH-SC238 2-3/8" Raising Blocks.

CONE THERMO BEARING HEATERS

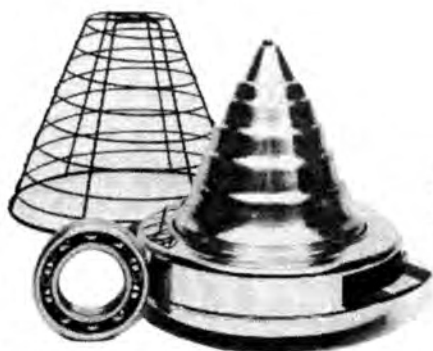

Part No. TBH-160

The New Way To Mount Bearings And Gears

Easy to use. Mark with Thermo Crayon. When crayon mark melts, slip bearing on shaft. Open, shielded and sealed bearings mounted without damage to lubricants. Safe, no danger of fire or explosion hazard. Heating time for small bearings is approximately two minutes, medium size five minutes, large bearings ten minutes or as required.

SPECIFICATIONS:

110 volts AC, 725 watts. Weight 8 lbs. Height 10". Mounts any bearing or gear with 3/4" to 8" bore. Comes complete with six foot heavy duty cord and switch, plus Thermo Crayon. Constructed of aluminum for fast heat transfer. Also available in 240V AC.

QUICK, POSITIVE BEARING INSTALLATION

SPECIFICATIONS: GROSS WEIGHT: 50 pounds. HEIGHT: 8-3/4 inches. LENGTH: 10 inches. THROAT WIDTH: 4-3/4 inches. THROAT HEIGHT under removable bars: 3-3/4 inches.

LARGE BAR: (cross-sections) 2" x 2" MEDIUM BAR: 1-1/4" x 1-1/4" SMALL BAR: 3/4" x 3/4" included. OPERATING CURRENT: 110 volts, 17 amps. Rated for 20 minute intermittent duty. Handles bearing sizes up to 10-1/2" O.D., 4-3/8" wide. For larger sizes,

Part No. TRBH-BC and **Part No. TRBH-BCS**, ask for specifications.

The use of Reco induction bearing heaters can now give you a superior method of applying heat to bearings under controlled conditions. Bearings can quickly be brought to proper heat while still in their wrapper. Protection from hazards, burns and fire danger.

APPROXIMATE HEATING TIMES FOR TYPICAL BEARINGS

BEARING	O.D. (IN.)	WIDTH (IN.)	TIME
6204	1.8504	.5512	1 min.
6209	3.3465	.7480	1 min.
6309	3.9370	.9843	1 min. 45 sec.
6310	4.3307	1.0630	2 min.
6313	5.5118	1.2992	4min.
6315	6.2992	1.4567	4 min.
6319	7.8740	1.7717	8min.

Note: Larger Bearing Heaters are available. Please contact your local branch for information and brochure.



Part No. TBH-190

Part No. TBH-160 Model B Bearing Heater for bearings to 5 3/4" bore.

Part No. TBH-170 Model C Heavy Duty Bearing Heater for bearings to 5 3/4" bore.

Part No. TBH-190 Model Super D Bearing Heater with temperature control for bearings to 8" bore.

HAND TOOLS & SHOP SUPPLIES

MARTINDALE UNIVERSAL



Including 4 "V" Cutters or 8 Saws

Part No. TUC-20 Undercutter with both slot guides and universal motor 115 or 230 V (specify which).

Part No. TUC-21 Undercutter with both slot guides and Swivel Connection, for use with your motor (specify shaft diameter).

Part No. TUC-22 Undercutter with both slot guides and Air Motor.

Part No. TUC-14-C Core (replacement for flexible shaft).

Part No. TUC-14-S Sheath (replacement for flexible shaft).

Part No. TUC-16-HS Saws 1/2" O.D. 3/16" hole.

Part No. TUC-17-VHS Cutters 1/2" O.D. 3/16" hole.

Universal in four ways; has universal electric motor or air motor; can be used on commutators of any diameter, cuts either "U" or "V" slots. The handles may be set at most convenient operating angle. The 1/5 HP electric motor is mounted on a swivel base, or may be suspended by its handle. Drive shaft is extremely flexible and light, though sturdy. (No.14, 1/4" diameter, 3 ft. long.) Net weight with 1/5 HP electric motor, 12-1/2" lbs., without motor, 2-1/4 lbs., with Air Motor, 2-1/2 lbs. Shipping weight with electric motor, 18 lbs., without motor, 3-1/2 lbs., with Air Motor, 4-1/2 lbs. Special telephone machine showing Universal Undercutter with angle slot guide for use on commutators up to 7" diameter. The 1/2" diameter saw allows cutting to within 1/4" of riser.

MARTINDALE JIFF-V UNDERCUTTER

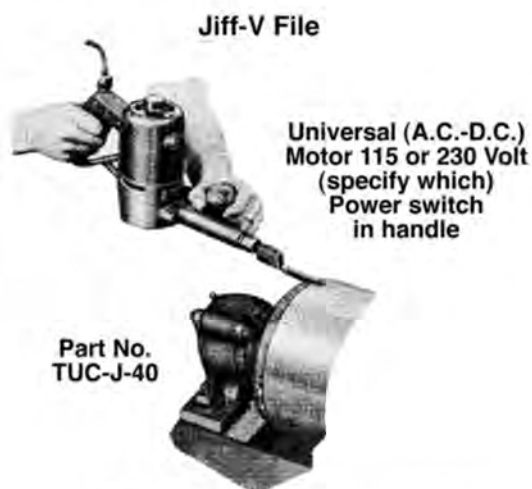

EASY TO GUIDE
Do not bear down on the Undercutter, merely guide it.

Its own weight exerts the proper pressure for free cutting and efficient motor speed.

Part No. TUC-J-40 Martindale Jiff-V Undercutter, 115 or 230 V, including six Jiff-V Files (High-Carbon Steel).

Part No. TUC-J-41 Martindale Jiff-V Undercutter, 115 or 230 V, including six Jiff-U Saws (specify thickness).

Part No. TUC-J-42 Extra Jiff-V Files, per dozen.

Part No. TUC-J-43 Extra Jiff-V Saws, per dozen.

Handy Commutator Slotting Files have always been popular for undercutting mica and are still recommended for use where there is not enough undercutting to justify the purchase of a motor-driven undercutting machine.

The motor-driven Jiff-V Undercutter cuts a similar V slot quickly. Also available for this undercutter are Jiff-U saws, which operate the same as the file except they make a U-shaped cut and are available in the following 7 thicknesses: .015", .020", .026", .030", .032", .035" and .040".

The Jiff-V does rapid work and cuts clear up to the riser. It can be used on commutators of any size without removing the brush arms.

The Jiff-V Undercutter has proven especially adaptable to under-cutting motors which must be kept running most of the time, such as elevator motors.

Even an inexperienced operator can use the Jiff-V without danger or damaging commutator bars.

HAND TOOLS & SHOP SUPPLIES

MARTINDALE HEAVY-DUTY BENCH-TYPE UNDERCUTTER MODEL H-9

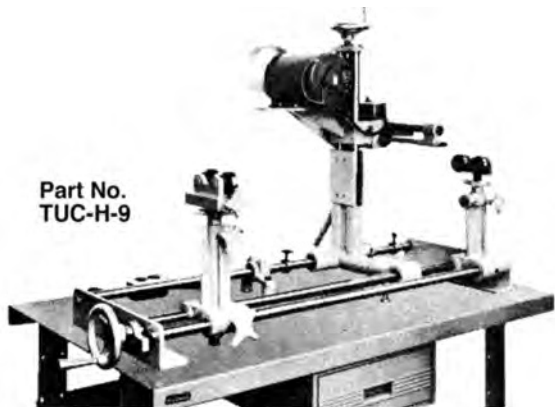

Part No.
TUC-H-9

Model H-9 uses either High-Speed Steel or Carbide Saws and V-cutters; handles armatures from the small sizes up to 17" diameter. This includes a range of sizes too large for Model HV-3 and not large enough to necessitate an Undercutter as large as the Shop-Type.

FEATURES:

Spindle speed easily changed for H.S. Steel or Carbide Saws. Cutting Head Carriage travels freely on ball-bushings on hardened steel rods; entire carriage tips to the side to facilitate lowering armatures onto the V-supports. Adjustment provided for aligning to skewed commutator bars. Rear Armature Support adjusted horizontally by a lead screw. Two spindles available (with 3/16" arbor for 1/2" diameter saws, or with 5/16" arbor for saws 7/8" diameter or larger). Machine comes equipped with one spindle; other at extra cost.

MARTINDALE LATHE-TYPE UNDERCUTTER

Saw Spindle Lengths:
3/16" arbor x 10 1/4"
5/16" arbor x 8 1/4"

Vertical adjustment
on support post 4 5/8"

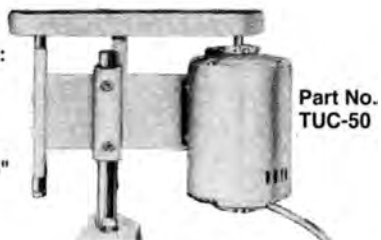

Part No.
TUC-50

The Lathe-Type Undercutter can be quickly attached in place of the tool post of any lathe. It can be mounted directly on the cross-slide, or on the slide carriage which is then mounted on the cross-slide.

The Slide Carriage is lever operated and is much faster than using the lathe traverse control. Travel is 11" with adjustable stops at both ends. A skewed bar adjustment is provided at the right end.

Both horizontal and vertical commutators can be undercut. As undercutting is done from the side of the commutator, the saw or V-cutter is set level with the lathe centers. Undercutter is powered by a 1/2 HP motor and uses high-speed steel saws or V-cutters.

SPECIFICATIONS

Maximum between centers 21", V-supports 35".

V-supports vertically adjustable.

Takes armatures 12" diameter on centers or 17" on V-supports.

Handles commutators up to same diameters as armatures.

Saw lifts out of slot on return stroke.

Stops limit saw travel.

Fine screw adjustment for depth of cut.

Motor: 1/2 HP, 3450 RPM.

Dimensions with bench: 4' L x 2' W x 5' H.

Part No. TUC-H-9 (115 or 230 volt, 60 Hz. - specify which), extra Pulley and Belt, one Saw Spindle (3/16" or 5/16" arbor - specify which) including bench and light.

Part No. TUG-H-10 Extra Saw Spindle (3/16" or 5/16" arbor).

Part No. TUG-H-11 Dust Collector with 2 hoods. Weight (incl. Dust Collector) - Net 280 lbs.; Ship., 400 lbs.

SAWS AND CUTTERS

HIGH SPEED STEEL	O.D. (IN.)	HOLE (IN.)
Part No. TUG-16-HS Saws	1/2	3/16
Part No. TUG-17-VHS Cutters	1/2	3/16
Part No. TUG-75-HS Saws	7/8	5/16
Part No. TUC-75-VHS Cutters	7/8	5/16
Part No. TUG-85-HS Saws	1	5/16
Part No. TUG-85-VHS Cutters	1	5/16
CARBIDE	O.D. (IN.)	HOLE (IN.)
Part No. TUG-16-TC Saws	1/2	3/16
Part No. TUG-17-VTC Cutters	1/2	3/16
Part No. TUC-75-TG Saws	7/8	5/16
Part No. TUG-75-VTC Cutters	7/8	5/16
Part No. TUG-85-TC Saws	1	5/16
Part No. TUC-85-VTC Cutters	1	5/16

FOB CLEVELAND, OHIO (All Items on Page)

A spring between hardened washers under the pulley allows the spindle to float up or down and follow an existing slot that is being re-cut. If a fixed spindle is desired, the spring can be removed and the pulley turned over.

Two spindles are furnished: one for 7/8" x 3/16" saws which turn at 2400 RPM, and one for 1/2" x 3/16" saws (cuts closer to riser) which turns at 5400 RPM.

To change spindles remove both pulleys - slide out one spindle and slide in the other. Put the 2" pulley on the 3/16" spindle, or the 3" pulley on the 5/16" spindle. The other pulley goes on the motor.

Including 4 "V" Cutters or 8 Saws

Part No. TUG-50 Lathe Type Undercutter (115 or 230 volt, 60 Hz. - specify which) complete with slide carriage and both spindles.

Part No. TUG-51 Lathe Type Undercutter (115 or 230 volt, 60 Hz. - specify which) for attaching directly to lathe and with both spindles.

EXTRA SAWS AND CUTTERS

HIGH SPEED STEEL	O.D. (IN.)	HOLE (IN.)
Part No. TUC-75-HS Saws	7/8	5/16
Part No. TUC-75-VHS Cutters	7/8	5/16
Part No. TUG-16-HS Saws	1/2	3/16
Part No. TUG-17-VHS Cutters	1/2	3/16

Specify voltage desired.

MARTINDALE BENCH-TYPE UNDERCUTTER MODEL HV-3

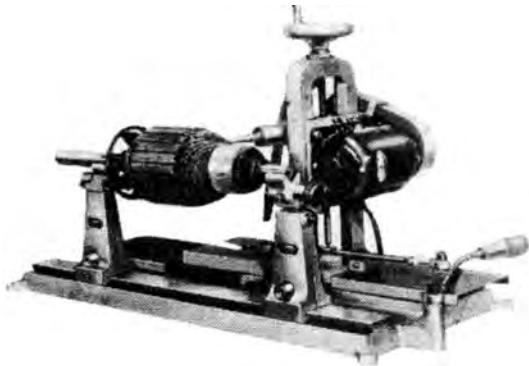

Horizontal commutator ready for support at right raised to compensate for smaller shaft diameter.

Uses either High-Speed or Tungsten-Carbide Saws and V-cutters. To change operation from High-Speed Steel to Carbide, or the reverse, it is necessary only to reverse pulleys (to change spindle speed).

Handles a wider variety of armature sizes and shaft lengths than any similar machine being manufactured.

This outstanding undercutter is designed to handle the large volume production undercutting of the motor manufacturer, as well as the wide variety of undercutting requirements encountered in the service shop.

TUC-HV-3 is precision built, rugged, fast and accurate.

Depth of cut is governed by a fine screw adjustment.

When the saw is being returned to the riser for the next cut, it is lifted clear of the slot for indexing.

Saws and Cutters - High-Speed Steel or Carbide

Two ball bearing spindles are available, with 1/8" or 3/16" arbors. The machine is equipped with one spindle only; additional spindle available at extra cost. For undercutting horizontal commutators only, the 1/8" spindle is recommended; with it the 1/8" hole saws listed are used. When both horizontal and vertical commutators are to be undercut, the 3/16" spindle is used, with the 3/16" hole saws or V-cutters.

MARTINDALE CLOSE-CUT COMMUTATOR UNDERCUTTER

The Close-Cut Undercutter was specially designed to finish off a mica slot when it is necessary to cut within 1/8" of a riser. Design of the Close-Cut Undercutter allows ample clearance between the undercutter and the commutator surface on even the largest commutators. This design is



Part No. TUC-1

accomplished by angling away the drive shaft and drive pulley with a length of flexible shafting, so no part of the undercutter can contact the riser before the saw has cut to the end of the bar. The shaft housing is very small and made of "Oillite" bearing bronze.

FEATURES:

- Undercuts horizontal and vertical commutators.
- Uses either High-Speed Steel or Carbide Saws and V-cutters.
- Carriage travels on ball bearings both horizontally and vertically.
- Saw Spindle is powered by a 1/5 HP, 5000 RPM. Universal (A.C.-D.C.) Motor with 10-ft. cord and line switch.
- Stops and adjustments are provided for safe and fast undercutting.
- One-piece rigid cast aluminum base with 6 compartment saw container. Net Weight 43 lbs. Shipping Weight 54 lbs.

Part No. TUC-HV-3 Bench-Type with AC-DC Motor and one Saw Spindle (1/8" or 3/16" arbor - specify which), (115 or 230 V- specify which).

Part No. TUC-HV-4 Extra Saw Spindle (1/8" or 3/16" arbor).

SAWS AND CUTTERS		
HIGH SPEED STEEL	O.D. (IN.)	HOLE (IN.)
Part No. TUC-9 1/2-HS Saws	5/16	1/8
Part No. TUC-32-HS Saws	3/8	1/8
Part No. TUC-1 6-HS Saws	1/2	3/16
Part No. TUC-17-VHS Cutters	1/2	3/16
Part No. TUC-13-HS Saws	11/16	3/16
Part No. TUC-13-VHS Cutters	23/32	3/16
CARBIDE	O.D. (IN.)	HOLE (IN.)
Part No. TUC-9 1/2-TC Saws	5/16	1/8
Part No. TUC-32-TC Saws	3/8	1/8

- 20" between centers.
- Longer armatures on V-supports, which can be spread to 23" between inside edges, and have 1" vertical adjustment.
- Takes armatures 10-1/2" diameter on centers or 12" on V-supports.
- Handles Commutators: Vertical - 5-1/4" diameter; Horizontal - 6-1/2" diam. x 6-1/2" long.

FEATURES:

- Cuts 1/16" deep with 3/4" diameter saw; .010" to .045" thick.
- Cuts 3/32" deep with 7/16" diameter saw; 010" to .045" thick.
- Cuts full depth to within 1/8" of riser.
- Saw spindle speed 6000 RPM.
- 1/10 HP A.C.-D.C. 115V, ball-bearing motor.
- Weighs only 3-3/4 lbs., Shipping weight 10 lbs.

SAWS:

Available in High-Speed Steel or Carbide. Stocked in the following thicknesses: .010", .015", .018", .020", .023", .025", .028", .030", .032", .035", .038", .040", .043" and .045". (Other thicknesses available.)

Part No. TUC-1 Close-Cut Undercutter, 115V A.C.-D.C. Motor comes with Spindle Wrench and Carrying Case.

FOB CLEVELAND, OHIO (All Items on Page)

HAND TOOLS & SHOP SUPPLIES



Part No.
TUC-K-31

Cuts either "U" or "V" slots.
1/5 HP Universal Motor.
Control switch in handle.
Overall length 16 1/2"
Weighs only 8 1/4 lbs.
Used on all sizes
of commutators.
Well balanced.
Easy to guide.

MARTINDALE MODEL K MICA-MILLER UNDERCUTTERS

POWERFUL, LIGHTWEIGHT, EASY TO USE

Model K Mica-Miller (115 or 230 volts - specify which) including 4 "V" Cutters or 8 Saws:

Part No. TUC-K-30 With "Small" Head.

Part No. TUC-K-31 With "Standard" head.

Part No. TUC-K-32 With "Heavy-Duty" Head.

Extra Interchangeable Heads only:

Part No. TUC-K-33 "Small." 3500 RPM full load saw spindle speed.

Part No. TUC-K-34 "Standard." 2800 RPM.

Part No. TUC-K-35 "Heavy-Duty." 1850 RPM.

Part No. TUC-K-36 Steel Carrying Case for Model K Mica-Miller.

The Model K Mica-Miller is an excellent all-around undercutter for industrial plants or repair shops, as it can be used in the shop or taken to the job, and can be operated on either A.C. or D.C. from any lighting circuit.

Three interchangeable heads make the Model K most versatile. Saws or "V" cutters from 23/32" to 1-1/4" diameter can be used to undercut commutators of virtually any size.

The slot guide provided on the two smaller heads is positioned by two sensitive screw adjustments. It may be swung out of the way when changing saws. Many operators find the Model K so easy to use they remove the guide entirely.

FOB CLEVELAND, OHIO

PEERLESS TYPE "UL" MICA UNDERCUTTER

The Peerless Type UL Mica Undercutter is for mounting on tool post compound of a conventional lathe. Use with tungsten carbide compound land undercutting saws. The standard spring loaded floating spindle is for use with 7/8" x 5/16" saws and will undercut commutators with a maximum O.D. of 22" and a 7" riser.

The powered carriage moves the undercutter on ball bushings which are mounted to round ways. The carriage is also equipped with limit switches and an adjustable stop for setting the distance of travel. Standard undercutting travel is 10-1/4".

Additional undercutting lengths and spindle sizes are also available to accommodate most any size commutator available.

Part No. TPL-86500 Type UL Mica undercutter, 115V, 1 Phase, 60 Hz.

FOB HANOVER, PENNSYLVANIA

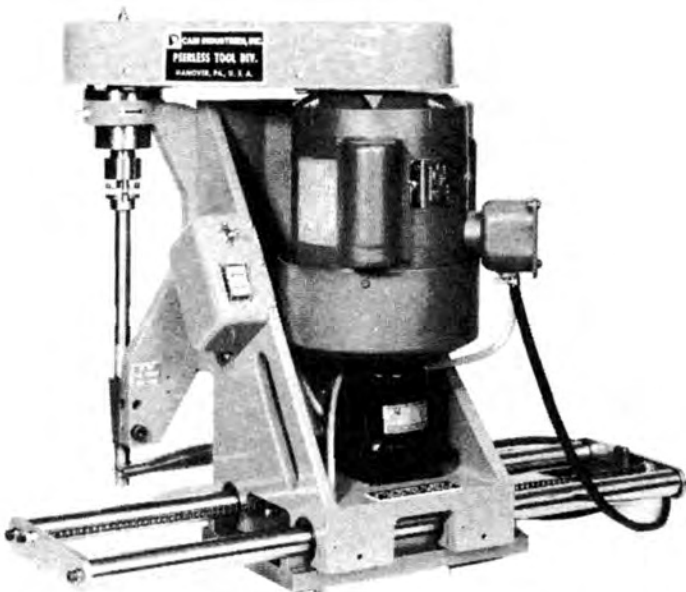

HAND TOOLS & SHOP SUPPLIES

IDEAL UNIVERSAL MODEL UNDERCUTTER



Part No.
TI-25-051

For undercutting large or small commutators, without removing brush riggings. Works in spaces only 2-3/4" wide and to within 1/4" of risers. Designed for heavy-duty service in both shop or field use. 1/4 HP motor connected to cutting spindle. The adjustable depth gauge, positive lock and roller guide ride in parallel slot in-suring accuracy. Uses 7/8" diameter, 5/16" bore saws and cutters.

Part No. TI-25-029 Undercutter with 1750 RPM, 1/4 HP, 115 VAC, 60 Hz motor; hanger and carrying case. Shipping weight 50 lbs.

Part No. TI-25-051 Undercutter Head with flexible shaft, less motor. Shipping weight 5 lbs.

IDEAL SMALL MODEL UNDERCUTTER



Part No.
TI-25-048

For undercutting small motor armatures. 1 to 7 inches. Holder centered, centerless or hollow shaft. Cutter head is removable for use in lathes or other holding devices. Shipping weight 22 lbs.

Uses 1/8" bore saws.

1/4" saw cuts 1/32" deep.

9/32" saw cuts 3/64" deep.

5/16" saw cuts 1/16" deep.

Part No. TI-25-048 Undercutter with 8000 RPM, 115V A.C.-D.C. motor.

FOB SYCAMORE, ILLINOIS

TRUCUT LATHES AND UNDERCUTTERS FOR ARMATURES AND ALTERNATORS

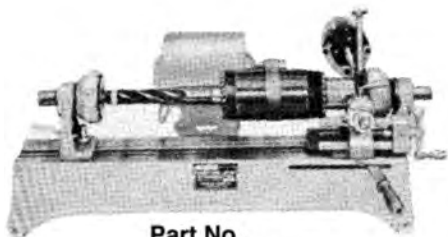

Part No.
TUC-SP-B15

Part No. TUC-SP-B15

Lathe with motorized undercutter and special 26" bed. Handles truck and bus, as well as passenger car and small motor armatures. Includes all parts illustrated plus two #240A steel centers and one #111C carbide tipped tool bit, but does not include M-160 motor.

SPECIFICATIONS:

Space between chucks	22 1/2" maximum
Chuck capacities	13/64" to 1 1/16"
Swing over bed	7 inches
Handles commutators to	3 1/2" diameter, 2 1/2" length
Bench space needed	14 1/2" X 28 1/2"

Part No. TUC-B-15 Lathe with Motorized Undercutter.

Faster and more convenient than using under-cutter drive belt, also saves cost of belt replacement. Complete as illustrated, but does not include M-160 motor.

SPECIFICATIONS:

Space between chucks	12 1/2" maximum
Chuck capacities	13/64" to 1 1/16"
Swing over bed	7 inches
Handles commutators to	3 1/2" diameter, 2 1/2" length
Bench space needed	14" X 18 3/4"

Part No. TUC-B-10 Lathe with Belt Driven Undercutter

Uses M-160 motor to turn armature or rotor and to drive undercutter. Undercutter belt molded of special belt compound. Complete as illustrated, but does not include M-160 motor.

SPECIFICATIONS: Same as TUC-B-15.

No. M-160 MOTOR, 1/4"HP, 115V 60C, 1725 RPM, CCW facing shaft end. Used on all lathes to turn armature or rotor and on TUC-B-10 to drive undercutter. Not included with lathes.

Order separately.

FOB WAUKESHA, WISCONSIN



Part No.
TUC-B-10

SHOP EQUIPMENT

DEREELING EQUIPMENT

**10x11x12
PAYOFF COMPLETE**
ESSEX® P/N L2116001C



REPLACEMENT PARTS

1.) 10x11x12 Replacement Hood with ceramic eyelet. Essex® P/N L2116002C

ACCESSORIES

- 2.) Custom made Whicker Disc, made to your specifications, available upon request.
3.) 10x11x12 Payoff Cap Essex® P/N L221001A

**10x11x12
PACKAGE #21**

NOTE: Above payoff can also be used with Essex® TF80 Spool Package.

NOTE: Above replacement parts will not work with any other dereeling assemblies available through Essex. Accessories not available for use with TF80 Spool Package.

PACKAGE	SIZE RANGE		NOM. CAPACITY-LBS.		PAYOFF METHOD	PAYOFF DEVICE	PAYOFF SPEED FPM NOM.	COMMENTS
	Copper	Alum.	Copper	Alum.				
REEL-PAK 100 (10x11x12 TAPER REEL)	25-32 AWG Rd.	23-26 AWG Rd.	85	25	Vertical over-the-flange. Angle over-the-flange. Vertical over-the-flange.	10x11x12 Dereeling hood. Whisker disc.	5000 5000 3000	Provides an excellent package for high speed dereeling of the intermediate wire sizes.

**HIGH SPEED IN CARTON
DEREELING ASSEMBLY**
ESSEX® P/N L218001A



**TF80 IN CARTON
PACKAGE #81**

NOTE: Above assembly can be used with 10x11x12 Package Reel in carton only.

REPLACEMENT PARTS

1.) Replacement Hood Essex® P/N L218001C

ACCESSORIES

2.) Tension Assembly Essex® P/N LREA26C4G1

PACKAGE	SIZE RANGE		NOM. CAPACITY-LBS.		PAYOFF METHOD	PAYOFF DEVICE	PAYOFF SPEED FPM NOM.	COMMENTS
	Copper	Alum.	Copper	Alum.				
TF80	25-32 AWG Rd.	23-26 AWG Rd.	85	25	Vertical over-the-flange. Angle over-the-flange. Vertical over-the-flange.	TF80 Dereeling hood.	7000 7000 4000	Provides an excellent package for high speed dereeling of the intermediate wire sizes.

25 RP COMPLETE
ESSEX® P/N L2113001C



REPLACEMENT PARTS

- 1.) 25 RP Replacement Hood Essex® P/N L2113003D
2.) Sponge Rubber Grommet Essex® P/N L2113006A
3.) Ceramic Eyelet Essex® P/N LBTRE34

ACCESSORIES

- 4.) 16" Payoff Cap for 25 RP Essex® P/N L2221001B
5.) Custom made Whisker Disc, made to your specifications, available upon request.

**250 REEL-PAK®
PACKAGE #25**

PACKAGE	SIZE RANGE		NOM. CAPACITY-LBS.		PAYOFF METHOD	PAYOFF DEVICE	PAYOFF SPEED FPM NOM.	COMMENTS
	Copper	Alum.	Copper	Alum.				
REEL-PAK 250 (12" TRAVERSE TAPER REEL)	12-24 AWG Rd.	12-22 AWG Rd.	250	75	Vertical over-the-flange.	25 RP Dereeling hood.	5000	An Essex development providing maximum dereeling efficiency.

PAYOFF CAPS

- 1.) 16" Payoff Cap for 25RP Essex® P/N L2221001B
2.) 12" Payoff Cap Essex® P/N L223001B
3.) 6" Payoff Cap Essex® P/N L224006A
4.) 10x11x12 Payoff Cap Essex® P/N L221001A

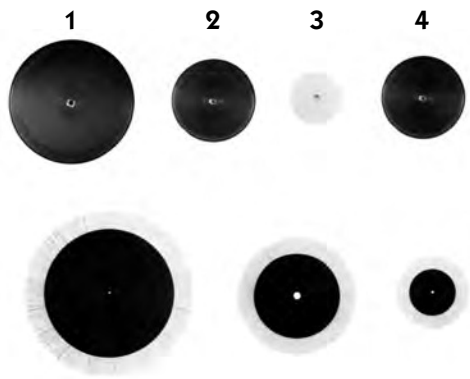

WHISKER DISCS

Special ordered to meet your manufacturing specifications and needs.

ORDERING INFORMATION NEEDED

- Wire Gauge
- Payoff Speed
- Diameter of Disc
- Number of Whiskers Per Inch

TENSION REGULATORS



STOCK NUMBER	DESCRIPTION	UNIT SIZE	WIRE WIRE RANGE
LBTRE34	Tension Regulator	1/4" Dia	40-50
LBTRE38	Tension Regulator	1/2" Dia	24-50
LBTRE10	Tension Regulator	3" Dia	14-30
LBTRE20	Tension Regulator	2" Dia	14 Round and Square to 100,000 sq. mils.



AO SMITH PUMP MOTOR PARTS

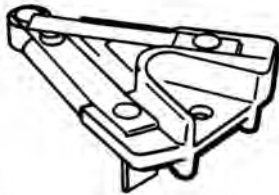

SAW-A

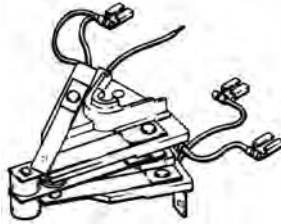

SAW-B

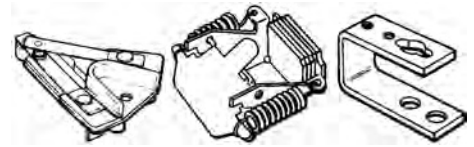

SAW-C

PHOTO REF.	CONTACTS N.O.	CONTACTS N.C.	MOUNTING HOLES C-TO-C (IN.)	PLATE SIZE WIDTH (IN.)	PLATE SIZE LENGTH (IN.)	SPADES FRONT	SPADES BACK	STUDS	I.D. (IN.)	FRAME SIZE/ NOTES	PART NUMBER
SAW-A	1	-	1	-	2	-	-	-	-	Contacts are 7/32" Dia.	SAW-25
SAW-A	1	-	1	-	2	-	-	-	-	Torq Replacement	STQ-25
SAW-A	1	-	1	-	1	-	-	-	-	Contacts are 1/4" Dia., 3" lead w/flag terminal	SAW-38
SAW-B	1	1	1	-	5	-	-	-	-		SAW-45
SAW-C	Switch Kit contains SAW-25, SAW-21-36 & SAW-33, small screw, nut and washer for bracket. An additional set of springs for 1800 RPM										SAW-30

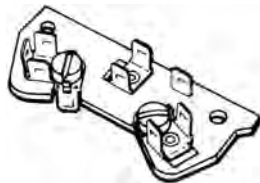

SAW-D

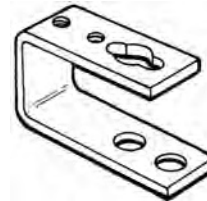

SAW-E

PHOTO REF.	MOUNTING HOLES C-TO-C	DIMENSIONS WIDTH (IN.)	DIMENSIONS LENGTH (IN.)	SPADES FRONT	SPADES BACK	STUDS	FRAME SIZE/ NOTES	PART NUMBER
SAW-D	2-3/8"	1-1/4"	3"	8"	3"	2(1)	Terminal Board (1) Screw terminals at L1 & L2	SAW-37
SAW-E	5/8"	5/8"	7/8 H	-	-	-	Mounting Bracket for SAW-25	SAW-33
SAW-E	7/16"	5/8"	1-1/16 H	-	-	-	Mounting Bracket for Stationary Switch	SAW-27

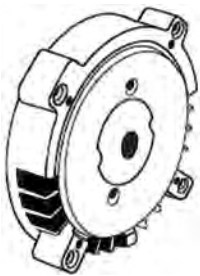

SAW-F

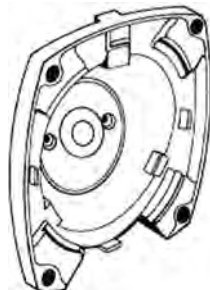

SAW-G

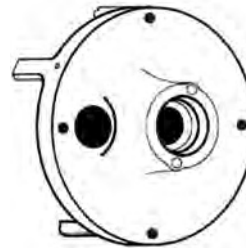

SAW-H

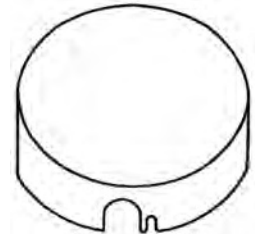

SAW-I

PHOTO REF.	BEARING SIZE	DESCRIPTION	PART NUMBER
SAW-F	6203	C-Flange endbell for pump motors	SAW-60
SAW-F	6304	C-Flange endbell for pump motors	SAW-51
SAW-G	6203	Square Flange endbell for pump motors	SAW-49
SAW-G	6204	Square Flange endbell for pump motors	SAW-50
SAW-H	6203	Opposite Drive End endbell for pump motors	SAW-52
SAW-I		Metal easy access cover for switch & capacitor (Back End Cover)	SAW-53
SAW-I		Metal easy access cover for switch & capacitor (New Style Back End Cover)	SAW-66

AO SMITH/WESTINGHOUSE MOTOR PARTS

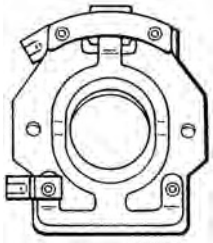

SWH-A

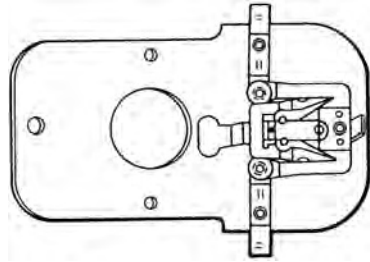

SWH-B

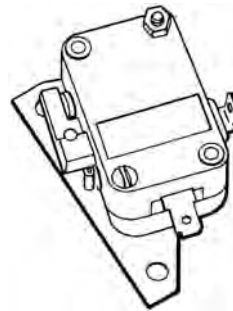

SWH-C

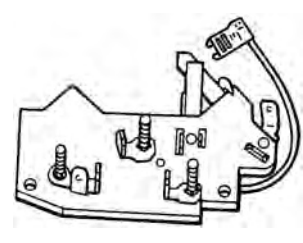

SWH-D

PHOTO REF.	CONTACTS		MOUNTING HOLES C-TO-C (IN.)	PLATE SIZE		SPADES		STUDS	I.D. (IN.)	FRAME SIZE/ NOTES	PART NUMBER
	N.O.	N.C.		WIDTH(IN.)	LENGTH(IN.)	FRONT	BACK				
SWH-A	1	-	1-7/8	2-3/8	2-3/4	-	-	-	1	-	SWH-1
SWH-B	1	1	1-7/8	2-5/8	4-3/8	3	-	-	-	# on unit R97-21	SWH-388
SWH-C	1	-	2-3/8	-	-	2	-	-	-	Dustite switch, Screws nuts & bracket included	SWH-349
SWH-D	1	-	2-15/16	1-13/16	3-3/4	1	4(1)	2(2)	-	(1) Doubles at 4 & 2, (2) at L1 & L2, 1 Lead	SWH-483

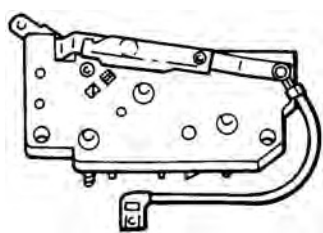

SWH-E

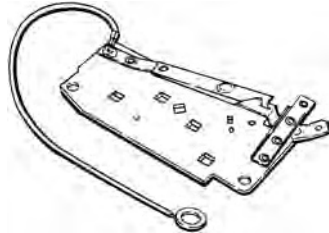

SWH-F

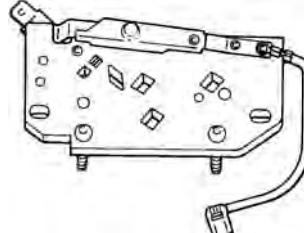

SWH-G

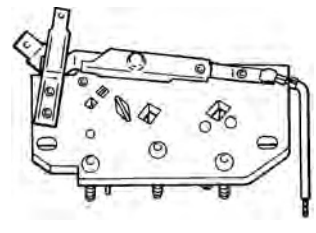

SWH-H

PHOTO REF.	CONTACTS		MOUNTING HOLES C-TO-C (IN.)	PLATE SIZE		SPADES		STUDS	I.D. (IN.)	FRAME SIZE/ NOTES	PART NUMBER
	N.O.	N.C.		WIDTH(IN.)	LENGTH(IN.)	FRONT	BACK				
SWH-E	1	-	2-15/16	1-1/2	3-5/16	-	5(1)	3(2)	-	(1) Singles at 4, L1 & Contact, Double at 2, (2) at L1, 4 & L2, 1 lead	SWH-395
SWH-E	1	-	2-15/16	1-1/2	3-5/16	-	4(1)	3(2)	-	(1) AT 1,2,4 & Contact (2) at 1,2,&4, 1 Lead	SWH-421
SWH-E	1	-	2-15/16	1-1/2	3-5/16	-	5(1)	2(2)	-	(1) Single at contact, Doubles at 2 & 4, (2) at L1 & L2, 1 Lead	SWH-398
SWH-E	1	-	2-15/16	1-1/2	3-5/16	-	1(1)	-	-	(1) at contact, 1 Lead	SWH-437
SWH-F	1	1	2-15/16	1-7/16	3-5/16	2	-	-	-	One Lead With Ring	SWH-458
SWH-G	1	-	3-1/16	1-3/4	3-7/16	-	5(1)	3(2)	-	(1) Singles at L1, 4 & contact, Double at 2 (2) at L1, 4 & L2, 1 Lead	SWH-400
SWH-G	1	-	3-1/16	1-3/4	3-7/16	-	1	-	-	1 Wire lead	SWH-413
SWH-G	1	-	3-1/16	1-3/4	3-7/16	-	5(1)	2(2)	-	(1) Single at Contact Double at 2 & 4 (2) At L1 & L2, One Lead	SWH-399
SWH-G	1	-	3-1/16	1-3/4	3-7/16	-	9(1)	3(2)	-	(1) Singles at L1, 5 & contact, Double at 1, 2 & 3 (2) at L1, 4 & L2, 1 Lead	SWH-428
SWH-G	1	-	3-1/16	1-3/4	3-7/16	-	5(1)	3(2)	-	(1) singles at L1, 4 & Contact, Double at L2 (2) at L1, 4, & L2, 1 Lead	SWH-436
SWH-G	1	-	3-1/16	1-3/4	3-7/16	-	5(1)	5(2)	-	(1) at 1, 2, 3, 4 & Contact (2) at 1, 2, 3, 4 & 6. 2 leads 1 Red & 1 Black	SWH-539
SWH-G	1	-	3-1/16	1-3/4	3-7/16	-	1	-	-	Heavy duty lead	SWH-544
SWH-G	1	-	3-1/16	1-3/4	3-7/16	-	6(1)	3(2)	-	(1) Singles at L1, 3, 5 & Contact Double at L2, (2)at L1, L2 & 3, 1 Lead W/ Ring Terminal	SWH-419
SWH-H	1	1	3-1/16	1-1/2	3-7/16	-	9(1)	3(2)	-	(1) Singles at L1, 5 & Contact, Doubles at 1, 2 & 3 (2) at L1, 4 & L2, 1 Lead	SWH-415
SWH-H	1	1	3-1/16	1-1/2	3-7/16	-	-	-	-	1 Lead	SWH-424

AO SMITH/WESTINGHOUSE MOTOR PARTS

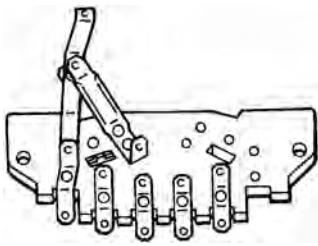

SWH-I

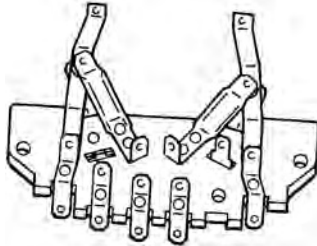

SWH-J

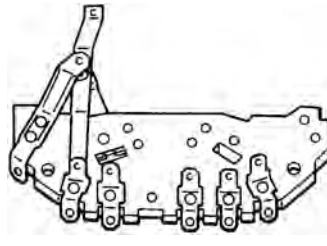

SWH-K

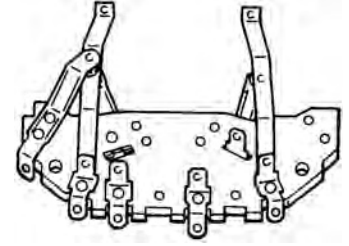

SWH-L

PHOTO REF.	CONTACTS		MOUNTING HOLES		PLATE SIZE		SPADES		FRAME SIZE/		PART NUMBER
	N.O.	N.C.	C-TO-C (IN.)	WIDTH (IN.)	LENGTH (IN.)	FRONT	BACK	STUDS	I.D.	NOTES	
SWH-I	1	-	3-3/8	1-7/16	3-3/4	6(1)	5	-	-	(1) at 4-Grn, 6-Brn, 5-Wht, 7-Blk, 1-Yel, & 8	SWH-379
SWH-I	1	-	3-3/8	1-7/16	3-3/4	4(1)	3	-	-	(1) at 2, 1, 4 & Blank	SWH-385
SWH-J	2	1	3-3/8	1-7/16	3-3/4	8(1)	5	-	-	(1) at 4,5,2,1,A,B,C&C	SWH-369
SWH-K	1	-	3-3/8	1-5/8	4-1/4	5(1)	6	-	-	(1) at Grn, Yel, Red, Wht & Blk	SWH-384
SWH-L	1	1	3-3/8	1-5/8	4-1/4	5(1)	5	-	-	(1) at Wht, Yel, Red, Grn & Blu	SWH-423

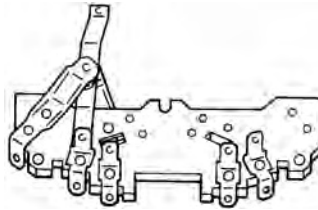

SWH-M

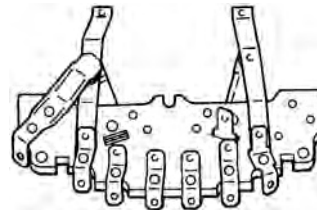

SWH-N

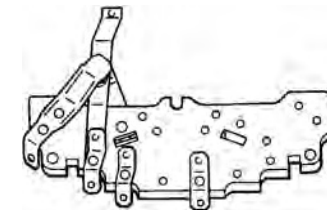

SWH-O

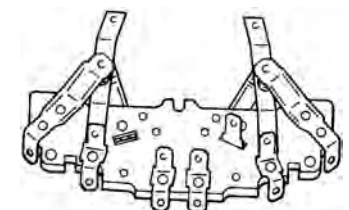

SWH-P

PHOTO REF.	CONTACTS		MOUNTING HOLES		PLATE SIZE		SPADES		FRAME SIZE/		PART NUMBER
	N.O.	N.C.	C-TO-C (IN.)	WIDTH (IN.)	LENGTH (IN.)	FRONT	BACK	STUDS	I.D.	NOTES	
SWH-M	1	-	3-3/4	1-1/2	4-1/4	4(1)	5	-	-	(1) at 6, 5, 2 & 1	SWH-482
SWH-N	1	1	3-3/4	1-1/2	4-1/4	7(1)	7	-	-	(1) at 2, 4, 3, 5, 1, 6 & 10	SWH-429
SWH-N	1	1	3-3/4	1-1/2	4-1/4	4(1)	4	-	-	(1) at 1, 2, 3 & 4	SWH-445
SWH-N	1	1	3-3/4	1-1/2	4-1/4	4(1)	4	-	-	(1) at Blk, Wht, Red & Brn	SWH-473
SWH-N	1	1	3-3/4	1-1/2	4-1/4	5(1)	5	-	-	(1) at 1, 2, 4, 6 & 10	SWH-475
SWH-N	1	1	3-3/4	1-1/2	4-1/4	5(1)	6	-	-	(1) at 1, 2, 3, 4 & 5	SWH-478
SWH-O	1	-	3-3/4	1-1/2	4-1/4	3	4	-	-	-	SWH-441
SWH-O	1	-	3-3/4	1-1/2	4-1/4	5(1)	6	-	-	(1) at Red, Yel, Blk, Brn & Wht	SWH-444
SWH-O	1	-	3-3/4	1-1/2	4-1/4	2(1)	3	-	-	(1) at 1 & 4	SWH-471
SWH-O	1	-	3-3/4	1-1/2	4-1/4	5(1)	6	-	-	(1) at Grn, Yel, Red, Wht & Blk	SWH-472
SWH-P	1	1	3-3/4	1-1/2	4-1/4	5(1)	6	-	-	(1) at 1, 2, 3, 4 & 7	SWH-432

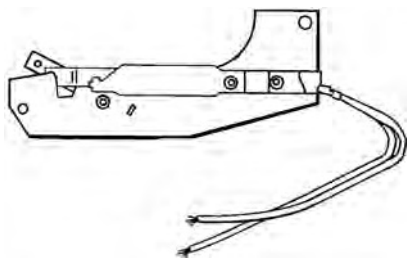

SWH-Q

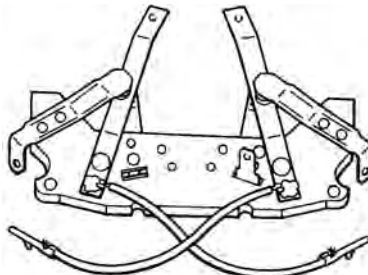

SWH-R

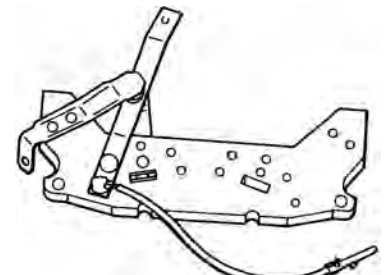

SWH-S

PHOTO REF.	CONTACTS		MOUNTING HOLES		PLATE SIZE		SPADES		FRAME SIZE/		PART NUMBER
	N.O.	N.C.	C-TO-C (IN.)	WIDTH (IN.)	LENGTH (IN.)	FRONT	BACK	STUDS	I.D.	NOTES	
SWH-Q	1	-	3-5/8	1-5/8	3-13/16	-	1	-	-	2 Leads	SWH-448
SWH-R	2	1	3-3/4	1-9/16	4-1/4	1	2	-	-	2 Leads in front	SWH-465
SWH-S	1	-	3-3/4	1-9/16	4-1/4	-	1	-	-	1 Blue lead in front	SWH-464

AO SMITH/WESTINGHOUSE MOTOR PARTS

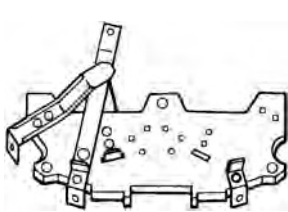

SWH-T

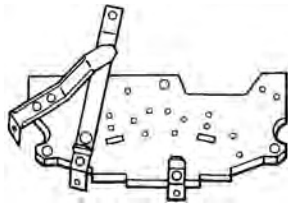

SWH-U

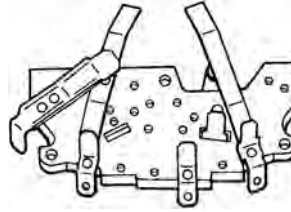

SWH-V

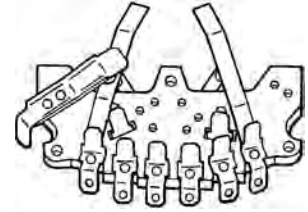

SWH-W

PHOTO REF.	CONTACTS		MOUNTING HOLES		PLATE SIZE		SPADES		STUDS	I.D.	FRAME SIZE/ NOTES	PART NUMBER
	N.O.	N.C.	C-TO-C (IN.)	WIDTH (IN.)	LENGTH (IN.)	FRONT	BACK					
SWH-T	1	1	3-3/4	1-7/8	4-1/4	3	3(1)	-	-	(1) at 1, 2 & 6	SWH-516	
SWH-U	1	-	3-3/4	1-7/8	4-1/4	2(1)	3	-	-	(1) at 1 & 4	SWH-449	
SWH-U	1	-	3-3/4	1-7/8	4-1/4	5(1)	6	-	-	(1) at 1-Red, 2-Yel, 3-Blk, 4-Brn & 6-Wht	SWH-461	
SWH-U	1	-	3-3/4	1-7/8	4-1/4	5(1)	6	-	-	(1) at Grn, Yel, Blk, Wht & Red	SWH-515	
SWH-V	1	1	3-3/4	1-7/8	4-1/4	4(1)	4	-	-	(1) at 1, 2, 3 & 4	SWH-463	
SWH-W	1	2	3-3/4	1-7/8	4-1/4	8(1)	7	-	-	(1) at 2, 4, 3, 5, 1, 6, 9 & 10	SWH-479	

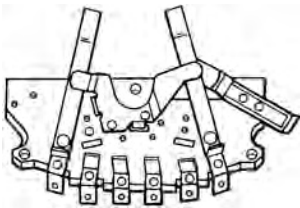

SWH-X

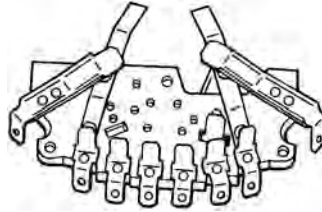

SWH-Y

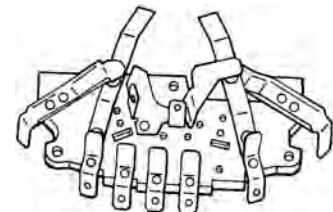

SWH-Z

PHOTO REF.	CONTACTS		MOUNTING HOLES		PLATE SIZE		SPADES		STUDS	I.D.	FRAME SIZE/ NOTES	PART NUMBER
	N.O.	N.C.	C-TO-C (IN.)	WIDTH (IN.)	LENGTH (IN.)	FRONT	BACK					
SWH-X	2	1	3-3/4	1-7/8	4-1/4	5(1)	4	-	-	(1) single at L0, Double at Com & H1	SWH-469	
SWH-Y	2	1	3-3/4	1-7/8	4-1/4	7(1)	8	-	-	(1) at Brn, Red, Yel, Wht, Blk, Org & Contact	SWH-485	
SWH-Z	2	1	3-3/4	1-7/8	4-1/4	7(1)	7	-	-	(1) at Brn, Red, Yel, Wht, Org, Blk & Blank	SWH-467	
SWH-Z	2	1	3-3/4	1-7/8	4-1/4	8(1)	8	-	-	(1) at 4-Red, 2-Blu, P-Blk, P-Blk, L-Wht, 5-Grn, 3-Yel, & Blank	SWH-484	
SWH-Z	2	1	3-3/4	1-7/8	4-1/4	7(1)	7	-	-	(1) at 1, 2, 3, 4, 6 & 10	SWH-466	

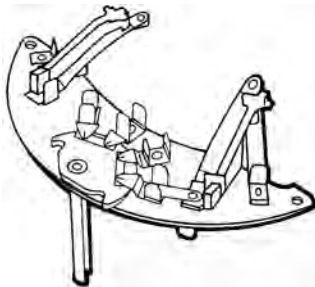

SWH-AA

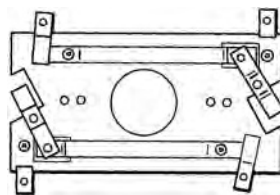

SWH-BB

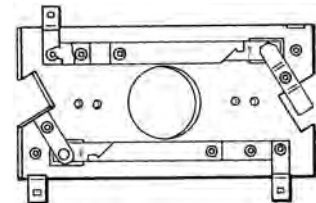

SWH-CC

PHOTO REF.	CONTACTS		MOUNTING HOLES		PLATE SIZE		SPADES		STUDS	I.D. (IN.)	FRAME SIZE/ NOTES	PART NUMBER
	N.O.	N.C.	C-TO-C (IN.)	WIDTH (IN.)	LENGTH (IN.)	FRONT	BACK					
SWH-AA	2	-	5-1/4	2-1/16	5-19/32	11	2	-	-	Includes Voltage change switch	SWH-510	
SWH-BB	2	2	1-7/8 & 2-3/8	2-1/8	4	6	-	-	1	-	SWH-396	
SWH-CC	1	1	1-7/8 & 2-3/8	2-1/8	4	4	-	-	1	-	SWH-366	

AO SMITH/WESTINGHOUSE MOTOR PARTS

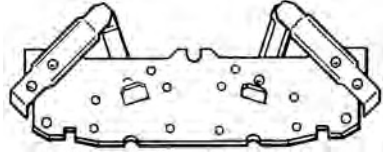

SWH-DD

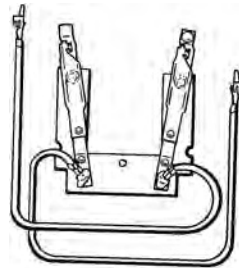

SWH-EE

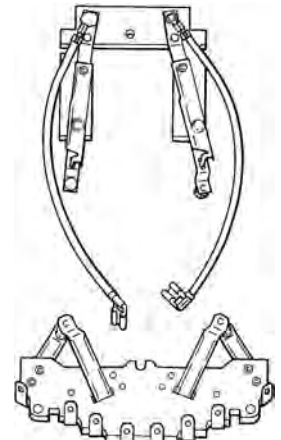

SWH-FF

PHOTO REF.	CONTACTS		MOUNTING HOLES		PLATE SIZE		SPADES		STUDS	I.D.	FRAME SIZE/ NOTES	PART NUMBER
	N.O.	N.C.	C-TO-C (IN.)	WIDTH (IN.)	LENGTH (IN.)	FRONT	BACK					
SWH-DD	2	1	3-3/8	1-1/4	4-1/4	2	1	-	-	Stationary contact plate, 2 contacts on left & 1 on right, Part of SWH-409	SWH-450	
SWH-DD	2	2	3-3/8	1-1/4	4-1/4	2	2	-	-	Stationary contact plate, 2 contacts on left & 2 on right, Part of SWH-410	SWH-460	
SWH-EE	2	2	2-1/2	2-5/8	2-3/8	-	-	-	-	1 Black & 1 Red lead, Moveable contact plate	SWH-470	
SWH-FF	2	1	2-1/2 & 3-3/8	-	-	8	7(1)	-	-	(1) at Brn, Red, Yel, Wht, Blk Org & contact	SWH-409	

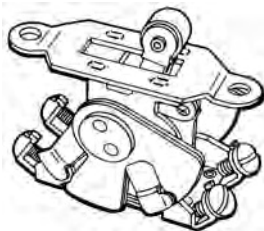

SWH-GG

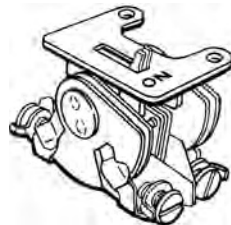

SWH-HH

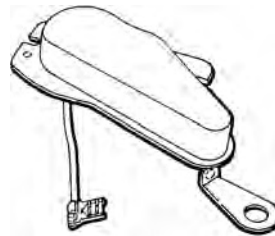

SWH-II



SWH-JJ

PHOTO REF.	# OF POLES	CURRENT RATING	MTG. C TO C (IN.)	NOTES	PART NUMBER
SWH-GG	2	30 Amp @ 250 V 1 Hp 480VAC 2 HP 120/240 VAC	2-3/8	Gas Pump Switch	PTS-8262S30
SWH-HH	2	20 Amp @ 250 V 1 HP 125/250 VAC	-	1-1/4" Gas Pump Switch (Pictured)	SWH-523
SWH-HH	2	20 Amp @ 250 V 1 HP 125/250 VAC	-	1-1/4" Gas Pump Switch	SWH-543
SWH-II	-	Float Actuated Switch	2-5/8	Sump Pump Switch	SWH-442
SWH-JJ	-	Weight Actuated Switch	-	2-13/16" Sump Pump Switch	SGE-753

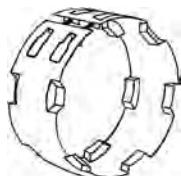

SAW-J

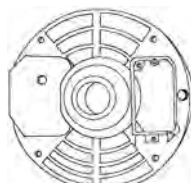

SAW-KK

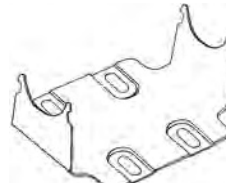

SAW-K

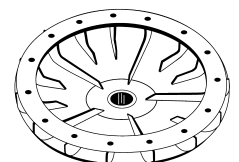

SAW-L

PHOTO REF.	DESCRIPTION	PART NUMBER
SAW-J	5-1/2" ID X 6-1/2" OD 3" Wide. Adapts 48 Fr. to 56 Fr. belly band mounting.	SAW-63
SAW-J	5-1/2" ID X 6-1/2" OD 1-1/2" Wide. Adapts 48 Fr. to 56 Fr. belly band mounting.	SAW-64
SWH-KK	Endbell ODP, for 6-1/2" Dia. motors, uses 6203 bearing, Opposite Drive End	SWH-545
SAW-K	Resilient cradle base 48 Fr. Mntg, 2-1/2" Ring, 7-1/2 Ring to Ring	SAW-65
SAW-L	Rain Shield & Fan Assembly for Vertical Condensor Fan Motors 1/2" Bore	SAW-61
SAW-L	Rain Shield & Fan Assembly for Vertical Condensor Fan Motors 5/8" Bore	SAW-62

BALDOR MOTOR PARTS

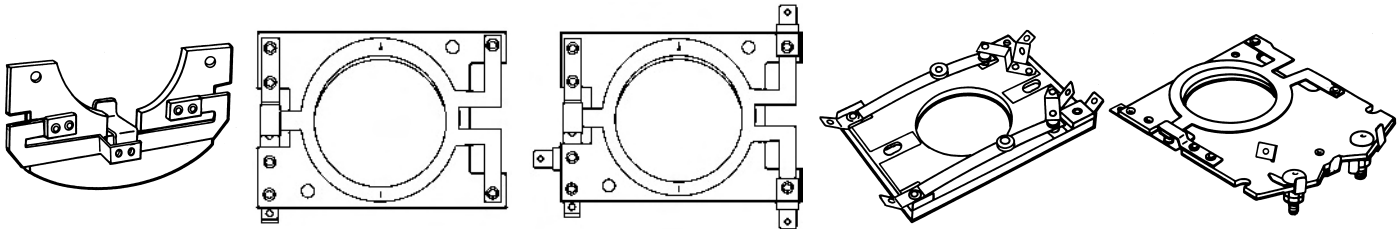

SBA-A

SBA-B

SBA-C

SBA-D

SBA-E

PHOTO REF.	CONTACTS		MOUNTING HOLES		PLATE SIZE		SPADES			FRAME SIZE/ NOTES	PART NUMBER
	N.O.	N.C.	C-TO-C (IN.)	WIDTH (IN.)	LENGTH (IN.)	FRONT	BACK	STUDS	I.D. (IN.)		
SBA-A	1	-	2-7/8	3-5/8	2-1/16	-	-	-	-		SBA-61
SBA-B	1	-	2-3/4	2-3/8	3-1/4	-	-	-	1-11/16	42,48,56,143-145	SBA-62
SBA-C	1	-	2-3/4	2-3/8	3-1/4	3	-	-	1-11/16	42,48,56,143-145	SBA-121
SBA-C	2	-	2-3/4	2-1/2	3-7/16	4	-	-	1-11/16	42,48,56,143-145	SBA-120
SBA-D	2	2	2-3/4	2-1/2	3-7/16	5	-	-	1-11/16	Used on Huebsch Dryer Motors	SMR-94
SBA-E	1	-	2-1/2 X 3-3/16	3-5/16	3-5/16	4	7(1)	2(2)	1-11/16	48 (1) Singles at L1, & 3 Double at 4, Triple at L2(2) At L1 & L2 on Bottom	SBA-78
SBA-E	1	-	2-7/8 X 3-3/16	3-3/16	3-5/16	4	7(1)	2(2)	1-11/16	56,143-145(1) Singles at L1 & 3, Double at 4, Triple at L2 (2) At L1 & L2 on Bottom	SBA-79

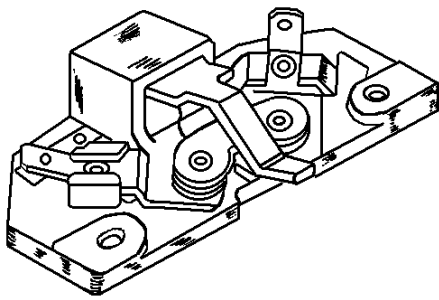

SBA-F

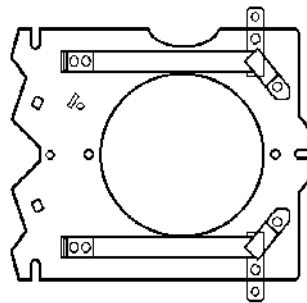

SBA-G

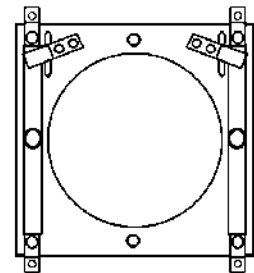

SBA-H

PHOTO REF.	CONTACTS		MOUNTING HOLES		PLATE SIZE		SPADES			FRAME SIZE/ NOTES	PART NUMBER
	N.O.	N.C.	C-TO-C (IN.)	WIDTH (IN.)	LENGTH (IN.)	FRONT	BACK	STUDS	I.D. (IN.)		
SBA-F	2	-	2-1/2	3-1/4	1-5/8	2	-	-	-	182-184,213-215	SBA-122
SBA-G	2	-	3-3/8	3-7/8	4-1/16	4	-	-	2-29/32	182-184,213-215	SBA-66
SBA-H	2	-	3-3/8	3-7/8	3-7/8	4	-	-	2-29/32	182-184,213-215 (Torq Replacement)	STQ-400

BELL & GOSSETT PUMP PARTS

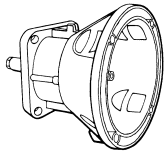

SBG-K

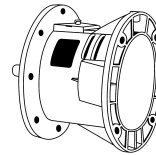

SBG-L

BEARING ASSEMBLIES

PUMP SERIES	INPUT SHAFT SIZE (IN.)	A PUMP BOLT CIRCLE (IN.)	B LENGTH (IN.)	C MOTOR BOLT CIRCLE (IN.)	IMPELLER SHAFT SIZE (IN.)	PHOTO REF.	PART NUMBER
Series 100 Iron Body	1/2	3-21/32	3-7/8	4-21/32	3/8 w/key	SBG-K	SBG-42
Series 100 All Bronze	1/2	3-21/32	3-7/8	4-21/32	3/8 w/key	SBG-K	SBG-37
Series 100 Iron Body	1/2	3-21/32	3-7/8	4-21/32	3/8 w/key	SBG-K	SBG-28
1-1/2", 2" & HV after 1976	1/2	4-1/2	3-11/32	4-21/32	3/8 w/key	SBG-K	SBG-43
1", 1-1/4", 1-1/2", 2-1/2", HLD3 Prior To 1950	1/2	4-1/2	3-5/16	5	3/8 w/key	SBG-K	SBG-29
2" IB; HV BI Prior To June 1976	1/2	4-1/2	3-5/16	5	3/8 w/key	SBG-K	SBG-52
2" BI; HV BI Prior To June 1976	1/2	4-1/2	3-5/16	5	3/8 w/key	SBG-K	SBG-53
PR, 2-1/2", LD3, HD3	1/2	5-7/16	3-5/16	5	3/8 w/key	SBG-K	SBG-38
PD 35&37, Series 60 & 1522	1/2	6	4-5/8	5-7/8	3/8 w/key	SBG-L	SBG-39

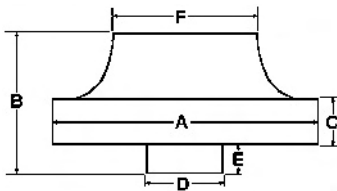

SBG-M

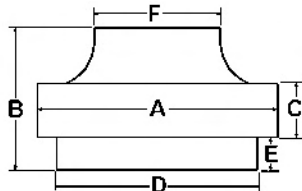

SBG-N

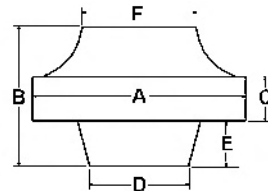

SBG-O

IMPELLERS

PUMP SERIES	A OVERALL DIA. (IN.)	B OVERALL THICK. (IN.)	C FIN THICK. (IN.)	D HUB DIA. (IN.)	E HUB THICK. (IN.)	F INLET DIA. (IN.)	MAT.	PHOTO REF.	PART NUMBER
Series 100	2-3/4	1-3/8	7/16	7/8	3/8	1-1/2	BZ	SBG-M	SBG-26
Series 100	2-3/4	1-3/8	1/2	1-1/4	5/8	1-1/2	Plastic	SBG-O	SBG-47
1" & 1-1/2" Old Style	3-1/8	1-1/4	9/16	7/8	1/16	1-1/2	Iron	SBG-M	SBG-60
HV & 2" Old Style	3-3/8	1-1/4	5/8	7/8	3/32	1-9/16	Iron	SBG-M	SBG-57
HV & 2" Old Style	3-3/8	1-1/4	5/8	7/8	3/32	1-9/16	BZ	SBG-M	SBG-58
HV & 2" New Style	3-3/8	1-9/16	5/8	7/8	3/8	1-7/16	Plastic	SBG-M	SBG-59
2-1/2" & LD3	3-7/8	2-1/2	1	3-3/8	1/2	2	BZ	SBG-N	SBG-62
PR Series	4-1/4	2-3/8	7/16	3-3/8	1/2	1-9/16	BZ	SBG-P	SBG-61
PR Series	4-1/4	2-3/8	7/16	3-3/8	1/2	1-9/16	Iron	SBG-P	SBG-64
HD3	4-1/4	2-1/2	1	3-3/8	1/2	2	Iron	SBG-N	SBG-63

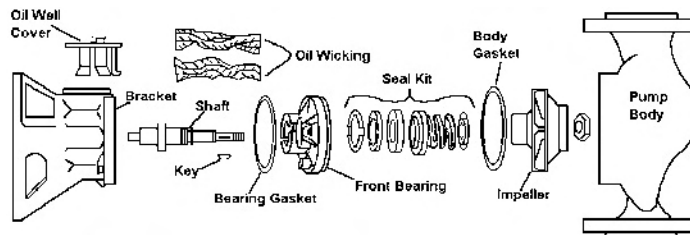

BEARING ASSEMBLY PARTS

BEARING ASSEMBLY	BODY GASKET	OIL WICK	FLANGE GASKET	SHAFT & SLEEVE	SEAL
SBG-28	SBG-44	SBG-56	SBG-46	SBG-25	PS-392
SBG-29	SBG-45	SBG-56	SBG-66	SBG-25	PS-392
SBG-37	SBG-44	SBG-56	SBG-46	SBG-25	PS-392
SBG-38	SBG-54	SBG-56	SBG-46	SBG-25	PS-392
SBG-39	SBG-55	SBG-56	SBG-65	SBG-25	PS-392
SBG-42	SBG-44	SBG-56	SBG-46	SBG-25	PS-392
SBG-43	SBG-45	SBG-56	SBG-66	SBG-25	PS-392
SBG-52	SBG-45	SBG-56	SBG-67	SBG-25	PS-392
SBG-53	SBG-45	SBG-56	SBG-67	SBG-25	PS-392

BELL & GOSSETT MOTOR PARTS

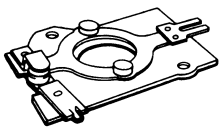

SBG-A

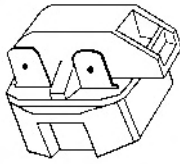

SBG-B

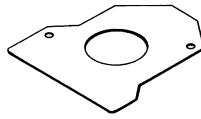

SBG-C

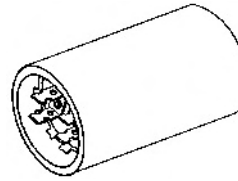

SBG-D

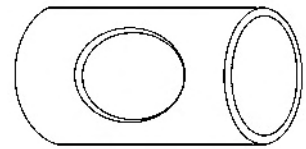

SBG-E

STARTING SWITCH

CONTACTS		MTG HOLES	WIDTH	LENGTH	NOTES	PHOTO REF.	PART NUMBER
N.O.	N.C.	CTR. TO CTR. (IN.)	(IN.)	(IN.)			
1	-	2-1/16	1-5/8	2-1/16	Used on 1/12 - 1/6 HP Motors	SBG-A	SBG-1B
1	-	2-3/16	1-5/8	2-3/16	Used on 1/6 - 3/4 HP Motors	SBG-A	SBG-9
-	1	-	-	-	Used on 1/12 HP Motors	SBG-B	8EA104
-	-	-	-	-	Mylar Insulator For SBG-1B	SBG-C	SBG-30

DRY RUN CAPACITORS

MFD	VOLT	SIZE (IN.)	NOTES	PHOTO REF.	PART NUMBER
8 (7.5)	240	1-7/16 X 3-3/8	Used on 1/6 HP Motors	SBG-D	SBG-8-240
22.5	330	1-13/16 X 3-3/8	Used on 1/3 & 1/2 HP Motors	SBG-D	SBG-22.5-330
30	240	1-13/16 X 3-3/8	Used on 1/2 HP Motors	SBG-D	SBG-30-240
40	240	1-13/16 X 3-3/8	Used on 3/4 HP Motors	SBG-D	SBG-40-240

SLEEVE BEARINGS

I.D. (IN.)	O.D. (IN.)	LENGTH (IN.)	NOTES	PHOTO REF.	PART NUMBER
1/2	21/32	13/16	Used on 1/12 & 1/6 HP	SBG-E	EB-1488
39/64	3/4	1	Used on 1/6 - 3/4 HP	SBG-E	EB-1382
15/16	1-1/16	1-1/4	Used on 1 - 2 HP (140T)	SBG-E	EB-1481
1-3/32	1-7/32	1-1/2	Used on 1 & 1-1/2 HP (180U)	SBG-E	WS-5692-C-BZ

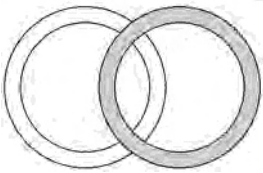

SBG-F



SBG-G

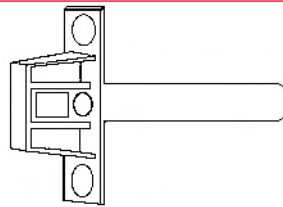

SBG-H

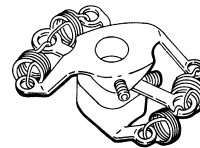

SBG-I

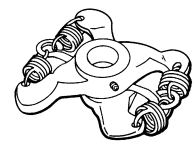

SBG-J

THRUST & SPACER WASHERS

I.D. (IN.)	O.D. (IN.)	NOTES	PHOTO REF.	NYLON PART NUMBER	RUBBER PART NUMBER	FIBER PART NUMBER
1/2	-	Used on 1/12 & 1/6 HP (EB-1488)	SBG-F	SBG-50	SBG-48	SBG-49
17/32	-	Used on 1/6 - 3/4 HP (EB-1382)	SBG-F	SBG-74	SBG-51	SBG-73
15/16	-	Used On 1 & 1-1/2 HP (EB-1481)	SBG-F	SBG-70	SBG-72	SBG-71

OIL WICKING AND OILER

DESCRIPTION	PHOTO REF.	PART NUMBER
Oil Wick For 1/12 & 1/6 HP Motors	SBG-G	SBG-69
Oil Wick For 1/6- 1/2 HP Motors	SBG-G	SBG-68
Oil Wick For 1 & 1-1/2 HP Motors	SBG-G	SBG-75
Oil well cover & oiler tube - used on 1/12 - 2 HP motors	SBG-H	SBG-41

COUPLERS

SHAFT SIZE MOTORXPUMP (IN.)	PUMP SERIES	NOTES	HP	PHOTO REF.	PART NUMBER
1/2 X 1/2	Series 100, 1", 2" & HV	Stamped Steel	1/12 & 1/6	SBG-I	SBG-18
1/2 X 1/2	Series 100, 1", 2" & HV	Cast Iron	1/6	SBG-J	SBG-27
1/2 X 1/2	2-1/2" & 3" Cast Iron Stiffer spring for higher HP	1/4 - 1/3 SBG-J	SBG-33		
1/2 X 1/2	PD35 & PD37, Series 60AA, 1522	Cast Iron Taller arm on 1/2 of coupler	1/2 - 3/4	SBG-J	SBG-36
5/8 X 1/2	PD35 & PD37, Series 60AA, 1522	Cast Iron	1/2 - 3/4	SBG-J	SBG-34
3/4 X 1/2	PD35 & PD37, Series 60AA, 1522	Cast Iron	1/2 - 3/4	SBG-J	SBG-35

BODINE MOTOR PARTS

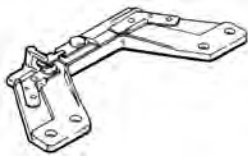

SBO-A

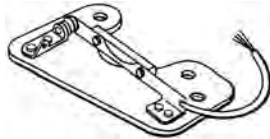

SBO-B



SBO-C



SBO-D

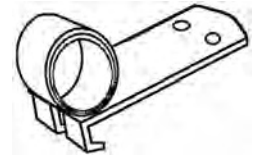

SBO-E

PHOTO REF.	CONTACTS N.O.	CONTACTS N.C.	MOUNTING HOLES C-TO-C (IN.)	PLATE SIZE WIDTH (IN.)	PLATE SIZE LENGTH (IN.)	SPADES FRONT	SPADES BACK	STUDS	I.D.	FRAME SIZE/ NOTES	PART NUMBER
SBO-A	1	-	2-1/8	1-3/8	3-5/16	2	-	-	-	Includes Mylar Insulator & 14" Lead	SBO-15
SBO-B	1	-	1-1/8	15/16	1-7/8	-	-	-	-		SBO-26
PHOTO REF.			WIDTH (IN.)	LENGTH (IN.)	NOTES				PART NUMBER		
SBO-C			11/16	2-1/4	Brush Cover Used on 42A & 42D series motors				SBO-28		
SBO-D			11/16	2	Brush Cover Used on 32A & 32D series motors				SBO-27		
SBO-E			3/8	.885	Used on 32A, 32D, 42A & 42D Series motors (Old Style)				SBO-29		
SBO-E			3/8	.830	Used on 32A, 32D, 42A & 42D Series motors (New Style)				SBO-30		

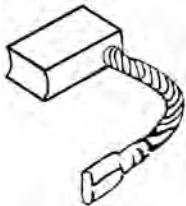

SBO-F

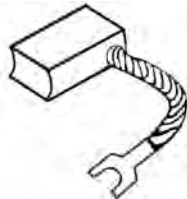

SBO-G

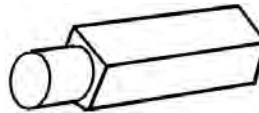

SBO-H



SBO-I

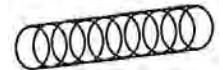

SBO-J

PHOTO REF.	THICK (IN.)	WIDTH (IN.)	LENGTH (IN.)	GRADE	FRAME SIZE	NOTES	PART NUMBER
SBO-F	0.246	0.371	0.75	F83	32A & 32D	Old Style W/ Quick Connect Terminal	SBO-32
SBO-G	0.246	0.371	0.75	F83	32A & 32D	New Style W/ Spade Terminal	SBO-40
SBO-F	0.246	0.371	0.843	F83	42A & 42D	Old Style W/ Quick Connect Terminal	SBO-33
SBO-G	0.246	0.371	0.843	F83	42A & 42D	New Style W/ Spade Terminal	SBO-41
SBO-H	0.121	0.246	0.75	F83	N1		SBO-37
SBO-H	0.180	0.246	1	F83	N3		SBO-31
SBO-I	0.246	0.371	1	F83	N3	With Spring & Pigtail	SBO-35
SBO-H	0.216	0.371	1.12	F83	N5		SBO-36
PHOTO REFERENCE	DIAMETER (IN.)	LENGTH (IN.)	WIRE DIAMETER (IN.)	FRAME SIZE		NOTES	PART NUMBER
SBO-J	0.225	2	0.0159	N3			SBO-38
SBO-J	0.294	2	0.02	N5			SBO-39

For Century Motor Parts - See the Magnetek Section

DEWALT MOTOR PARTS

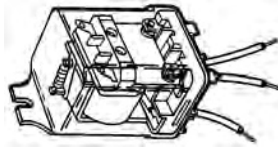

RPTA-A

PHOTO REF.	CONTACTS		MOUNTING HOLES C-TO-C (IN.)		DIMENSIONS (IN.)	NOTES	PART NUMBER
	N.O.	N.C.					
RPTA-A	-	2	2-5/8		1-1/2 X 1-1/2 X 2-1/4	Magnecraft # 389ADYCX-39 Operates at 150 Volt Replaces 500131	RPTA-53

DOERR MOTOR PARTS

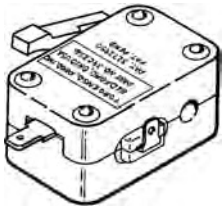

STQ-E

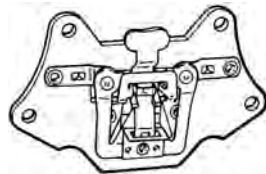

SDO-A

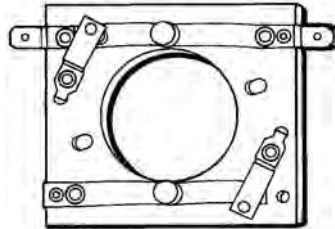

SDO-B

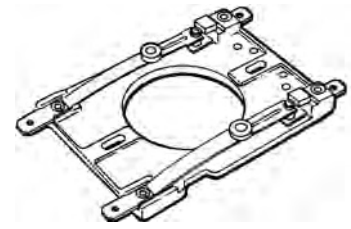

STQ-A

PHOTO REF.	CONTACTS		MOUNTING HOLES C-TO-C (IN.)		PLATE SIZE (IN.)		SPADES			I.D. (IN.)	FRAME SIZE/NOTES	PART NUMBER
	N.O.	N.C.			WIDTH	LENGTH	FRONT	BACK	STUDS			
STQ-E	1	-	1-5/8 (1-7/8 diag.)		1-5/16	2-3/32	2	-	-	-	Dustite switch 1" high	SCN-452
SDO-A	1	1	1-13/16 X 2-3/4		2-1/8	3-1/8	3	-	-	-	Instant reverse switch W/QC terminals # R98-6	SIF-12
SDO-A	1	1	1-13/16 X 2-3/4		2-1/8	3-1/8	-	-	-	-	Instant reverse switch W/O terminals # R99-1	SIF-4
SDO-B	1	-	1-7/8		2-3/8	2-9/16	2	-	-	1-13/32	-	SOH-59
STQ-A	2	-	2-9/16 X 2-3/4		2-1/2	3-1/2	4	-	-	1-11/16	Includes Wire Jumper	STQ-200

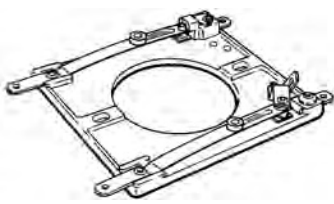

SDO-C

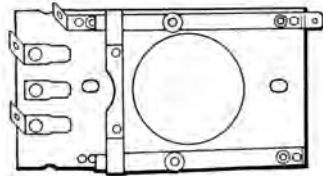

SDO-D

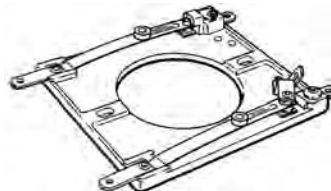

STQ-B

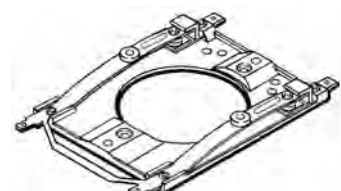

STQ-C

PHOTO REF.	CONTACTS		MOUNTING HOLES C-TO-C (IN.)		PLATE SIZE (IN.)		SPADES			I.D. (IN.)	FRAME SIZE/NOTES	PART NUMBER
	N.O.	N.C.			WIDTH	LENGTH	FRONT	BACK	STUDS			
SDO-C	2	1	2-9/16 X 2-3/4		2-1/2	3-1/2	5	-	-	1-11/16	-	SDO-13
SDO-D	1	-	2-11/16		2-11/32	4-3/16	4	6(1)	-	1-11/16	(1) at L, 1, 2, 3, 4 & L	SDO-6
STQ-B	2	-	2-11/16 X 2-3/4		3-1/16	3-1/2	4	-	-	1-15/16	Includes Wire Jumper	STQ-250
STQ-C	2	-	2-3/4		3-1/4	3-7/8	4	-	-	2-1/4	Metal jumper installed on one end	STQ-300

ELECTRA MOTOR PARTS

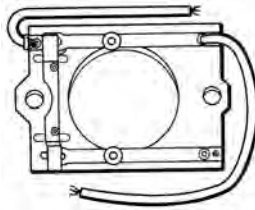

SELC-A

PHOTO REF.	CONTACTS		MOUNTING HOLES C-TO-C (IN.)	PLATE SIZE		SPADES			I.D. (IN.)	FRAME SIZE/ NOTES	PART NUMBER
	N.O.	N.C.		WIDTH (IN.)	LENGTH (IN.)	FRONT	BACK	STUDS			
SELC-A	1	-	3	2-9/16	3-5/8	-	-	-	1-7/8	2 Wire Leads	SELC-1

EMERSON MOTOR PARTS

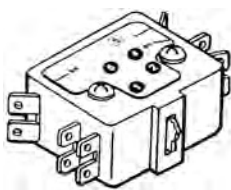

SEM-A

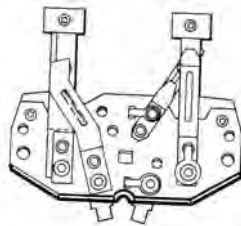

SEM-B

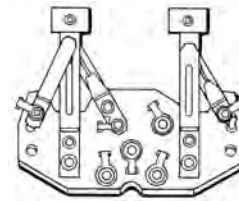

SEM-C

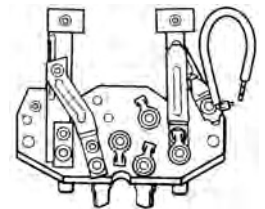

SEM-D

PHOTO REF.	CONTACTS		MOUNTING HOLES C-TO-C (IN.)	PLATE SIZE		SPADES			I.D. (IN.)	FRAME SIZE/ NOTES	PART NUMBER
	N.O.	N.C.		WIDTH (IN.)	LENGTH (IN.)	FRONT	BACK	STUDS			
SEM-A	-	-	1-5/32	1-1/2	1-31/32	6(1)	-	-	-	(1) Double at 1-RED, 6-BLK, BK, Y, B & 2 RED	SEM-382
SEM-A	-	-	1-5/32	1-1/2	1-31/32	10(1)	-	-	-	(1) Double at Blank, 3, 2, 4, P, 1, P, 5, Blank & Blank	SEM-385
SEM-A	-	-	1-5/32	1-1/2	1-31/32	6(1)	-	-	-	(1) Double at Blank, Blank, Blank, H, C, L	SEM-387
SEM-A	-	-	1-5/32	1-1/2	1-31/32	6(1)	-	-	-	(1) Double at BU, W, OR, Y, BK & BK	SEM-388
SEM-A	-	-	1-5/32	1-1/2	1-31/32	8(1)	-	-	-	(1) Double at Blank, PU, BR, OR, W, W-R, Blank & R-W	SEM-389
SEM-A	-	-	1-5/32	1-1/2	1-31/32	6(1)	-	-	-	(1) Double at GRN, YEL, BLANK, RED WHT & BLU	SEM-390
SEM-A	-	-	1-5/32	1-1/2	1-31/32	7(1)	-	-	-	(1) Double at 1, 2, 3, 4, 5, 6 & 7	SEM-395
SEM-B	1	1	2-15/16	-	-	-	4(1)	-	-	(1) at 1, 2, 3 & 4, 3 Solder terminals in front, Reinforced	SEM-244
SEM-B	1	1	2-15/16	1	1	1	4(1)	2(2)	-	(1) at 1, 2, 4 & 5, (2) at 1 & 5 in back, 3 solder terminals in front, Reinforced	SEM-247
SEM-B	1	1	2-15/16	-	-	-	4(1)	-	-	(1) at 2, 1, 3 & 4 3 Solder terminals in front, Reinforced	SEM-325
SEM-B	1	1	2-15/16	-	-	-	5(1)	-	-	(1) at 1-GRN, 2-BLU, 3-YEL, 4-RED & 5-WHT, 4 Solder terminals in Front Reinforced	SEM-326
SEM-C	2	1	2-15/16	-	-	-	7(1)	-	-	(1) at A, B, C, 1, 2, 4 & 5, 4 Solder terminals & 1 Wire jumper in Front, Reinforced	SEM-248
SEM-C	2	1	2-15/16	-	-	6(1)	-	-	-	(1) at BRN, YEL, WHT, RED BLK & OR, 7 Solder terminals in front, Reinforced	SEM-308
SEM-D	1	1	2-15/16	-	-	6(1)	-	-	-	(1) at 1, 2, 3, 4, 6 & 7 6 Solder terminals & 1 Wire lead in front, Reinforced	SEM-283

EMERSON MOTOR PARTS

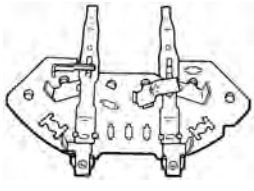

SEM-E



SEM-F

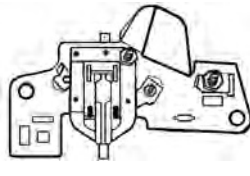

SEM-G



SEM-H

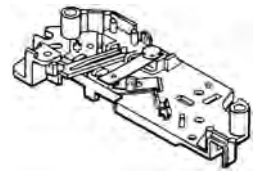

SEM-I

PHOTO REF.	CONTACTS N.O.	CONTACTS N.C.	MOUNTING HOLES C-TO-C (IN.)	PLATE SIZE WIDTH(IN.)	PLATE SIZE LENGTH(IN.)	SPADES FRONT	BACK	STUDS	I.D.	FRAME SIZE/ NOTES	PART NUMBER
SEM-E	2	1	3-1/2	-	-	5(3/16" Wide)	-	-	-	-	SEM-335
SEM-F	1	-	3-1/2	1-13/16	4-1/4	2(3/16" Wide)	-	-	-	-	SEM-362
SEM-G	2	-	3-7/16	1-7/8	3-7/8	4(3/16" Wide)	2	3	-	Green Plastic	SEM-415
SEM-G	2	1	3-7/16	1-7/8	3-7/8	5(3/16" Wide)	3	3	-	Red Plastic	SEM-416
SEM-H	1	-	3-5/8	1-19/32	4-1/2	6(3/16" Wide)	5	3	-	-	SEM-401
SEM-I	1	-	3-5/8	2	4-1/2	3(3/16" Wide)	5	3	-	-	SEM-180

FLINT & WALLING MOTOR PARTS

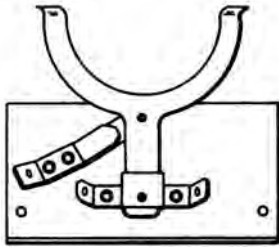

SFW-A

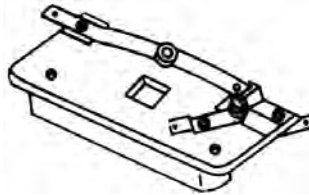

SFW-B

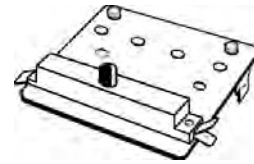

SFW-C

PHOTO REF.	CONTACTS N.O.	CONTACTS N.C.	MOUNTING HOLES C-TO-C (IN.)	PLATE SIZE WIDTH(IN.)	PLATE SIZE LENGTH(IN.)	SPADES FRONT	BACK	STUDS	I.D.	FRAME SIZE/ NOTES	PART NUMBER
SFW-A	1	-	2-5/8	1-1/2	3	3	-	-	-	Use on 92J Series Motors	SFW-6
SFW-B	1	-	2-5/8	1-15/32	3-9/16	3	-	-	-	Use on 92J Suffix A Series Motors	SFW-9
SFW-C	1	-	2-5/8	2-7/8	3-3/8	2	10	-	-	Use on 94J, 94H, 94L, & 94U Series Motors.	SFW-13

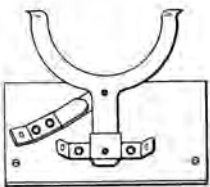

SFW-D

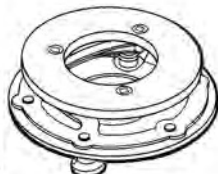

SFW-E

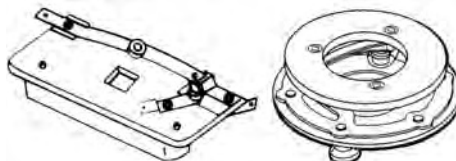

SFW-F

PHOTO REF.	REMARKS	PART NUMBER
SFW-D	Use on 92J Series Motors, .767 Dia. Shaft, Includes SFW-6 & SFW-7-36	SFW-5
SFW-E	Use on 92J Suffix A Series Motors, .667 Dia. Shaft, Includes SFW-9 & SFW-10-36	SFW-11
SFW-F	Use on 94J, 94H, 94L & 94U Series Motors, .667 Dia. Shaft, Includes SFW-13 & SFW-15-36	SFW-14

FRANKLIN MOTOR PARTS

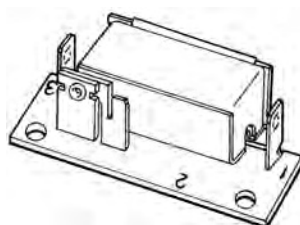

SFK-A

MFG #	HP RATING	PART NUMBER
294611901	2 & 2-1/2	Use SFK-53
294611902	1-1/2	Use SFK-54
294611903	1	Use SFK-48
294611904	1-1/2	Use SFK-60
294611905	3/4 & 1	Use SFK-48
294613980	1-1/2	SFK-87
294614902	3	SFK-58
294614903	2 & 2-1/2	SFK-64
294614906	1-1/2	SFK-59
294614907	2	SFK-37
294614980	2 & 2-1/2	SFK-53
294614981	3	SFK-54
294616902	1-1/2 & 2	SFK-60
294616903		SFK-61
294616904	1 & 1-1/2	SFK-51
294616905	3/4 & 1	SFK-48
294621903	3/4	Use SFK-52
294621904	1	Use SFK-43
294621905	3/4	SFK-46

MFG #	HP RATING	PART NUMBER
294622904	1/3	Use SFK-35
294622905	1/2 & 3/4	SFK-38
294622909		SFK-42
294622980	3/4	SFK-47
294623906	1	SFK-81
294624906	3/4	SFK-52
294624907	1	SFK-43
294625981		SFK-63
294626901	1	Use SFK-48
294631901	1/2	Use SFK-48
294632902	1/3 & 1/2	SFK-35
294632905	1/2 & 3/4	SFK-49
294633902		Use SFK-44
294633903		SFK-44
294635903	1/2	SFK-78
294642902	1/2	SFK-50
294642903		SFK-62
297323903		SFK-40

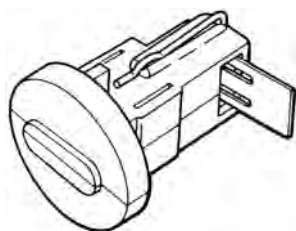

SFK-B

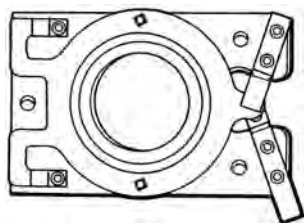

SFK-C

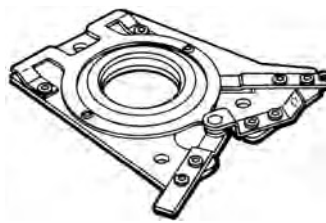

SFK-D

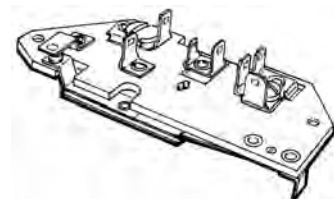

SFK-E

PHOTO REF.	CONTACTS		MOUNTING HOLES		PLATE SIZE		SPADES			I.D. (IN.)	FRAME SIZE/NOTES	PART NUMBER
	N.O.	N.C.	C-TO-C (IN.)	WIDTH (IN.)	LENGTH (IN.)	FRONT	BACK	STUDS				
SFK-B	1	-	-	-	1-9/32	-	-	-	-	-		SFK-30
SFK-C	1	-	1-1/2 X 2-9/16	2-1/8	3-3/16	1	-	-	1-1/16			SFK-6
SFK-C	1	1	1-1/2 X 2-9/16	2-1/8	3-3/16	2	-	-	1-1/16			SFK-31
SFK-D	2	1	1-1/2 X 2-9/16	3	3-3/16	2	-	-	1-1/16	1 Solder terminal in front		SFK-7
SFK-D	2	1	1-1/2 X 2-9/16	3	3-3/16	2	-	-	1-1/16	Includes MYLAR insulator, 1 Solder terminal in front, Large 3/8" Dia. aux. contact		SFK-83
SFK-E	1	-	3-1/4	1-1/2	3-9/16	7(1)	5 (2)	-	-	(1)Single at L1 & 3, Double at 4 Triple at L2, (2) 2 Screws at L1 & L2		SFK-21
SFK-E	1	-	3-1/4	1-1/2	3-9/16	5(1)	6 (2)	-	-	(1)Single at L1 & 4 Triple at L2,(2) 2 Screws at L1 & L2		SFK-22
SFK-E	1	-	3-1/4	1-1/2	3-9/16	4(1)	4 (2)	-	-	(1)Single at L1 Triple at L2, (2) 2 Screws at L1 & L2		SFK-23

FRANKLIN MOTOR PARTS

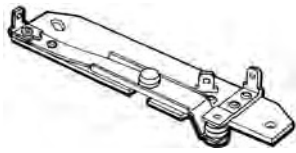

SFK-F

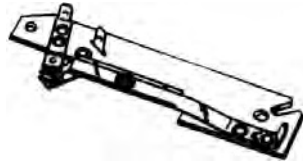

SFK-G

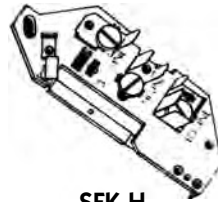

SFK-H

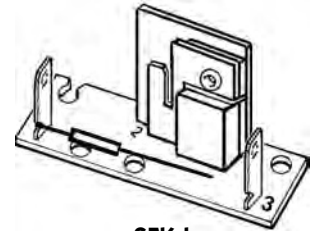

SFK-I

PHOTO REF.	CONTACTS		MOUNTING HOLES		PLATE SIZE		SPADES			I.D. (IN.)	FRAME SIZE/ NOTES	PART NUMBER
	N.O.	N.C.	C-TO-C (IN.)	WIDTH (IN.)	LENGTH (IN.)	FRONT	BACK	STUDS				
SFK-F	1	1	3-3/16	15/16	3-3/4	3	-	-	-	-	Auxillary switch	SFK-32
SFK-G	1	1	3-3/8	1	3-7/8	3	-	-	-	-	Auxillary switch	SFK-45
SFK-H	1	-	3-1/4	1-7/16	3-7/8	6	4	(1)	-	-	(1) 3 Screw terminals	SFK-56
SFK-I	-	-	1-5/8	3/4	2	3	-	-	-	-	Triac Switch	SFK-86

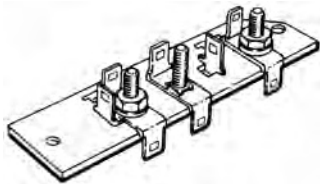

SFK-J

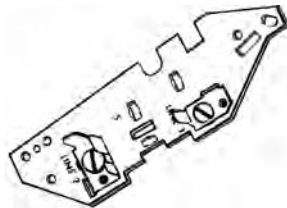

SFK-K

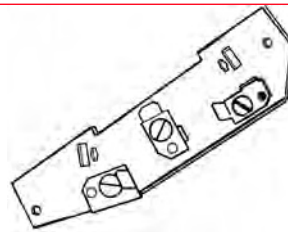

SFK-L

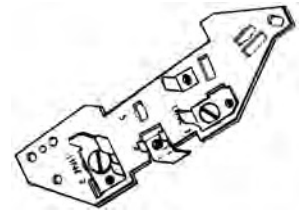

SFK-M

PHOTO REF.	CONTACTS		MOUNTING HOLES		PLATE SIZE		SPADES			I.D. (IN.)	FRAME SIZE/ NOTES	PART NUMBER
	N.O.	N.C.	C-TO-C (IN.)	WIDTH (IN.)	LENGTH (IN.)	FRONT	BACK	STUDS				
SFK-J	-	-	3-3/16	29/32	3-9/16	5	3	3	-	-	-	SFK-29
SFK-K	-	-	3-1/4	1-1/2	3-21/32	4	2	(1)	-	-	(1) 2 Screw terminals	SFK-88
SFK-L	-	-	3-1/4	1-3/16	3-9/16	3	3	(1)	-	-	(1) 3 Screw terminals	SFK-79
SFK-M	-	-	3-5/16	1-7/16	3-7/8	4	2	(1)	-	-	(1) 2 Screw terminals	SFK-66
SFK-M	-	-	3-5/16	1-7/16	3-7/8	8	4	(1)	-	-	(1) 2 Screw terminals	SFK-67
SFK-M	-	-	3-5/16	1-7/16	3-7/8	8	4	(1)	-	-	(1) 2 Screw terminals	SFK-76
SFK-M	-	-	3-5/16	1-7/16	3-7/8	7	3	(1)	-	-	(1) 2 Screw terminals	SFK-65

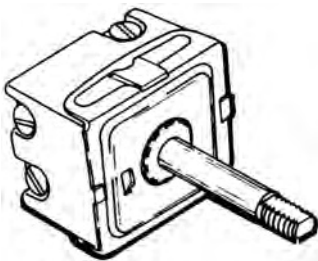

SFK-N

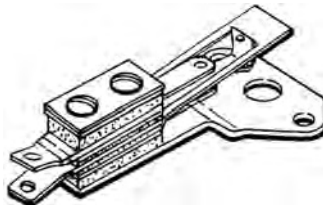

SFK-O

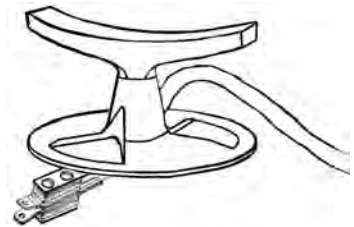

SFK-P

PHOTO REF.	CONTACTS		MOUNTING HOLES		WIDTH (IN.)	LENGTH (IN.)	NOTES	PART NUMBER
	N.O.	N.C.	C TO C (IN.)					
SFK-N	2	-	3/8 Thd.		1-11/32	1-1/2	1/4" x 1-3/8" Shaft, 37 amp @ 120/240V, DPST, 4 Screw terminals	SFK-33
SFK-O	1	-	7/8		3/8	2-1/4	2 Spade Terminals, Used on submatic motors	SFK-20
SFK-P	1	-	1-1/4				Handle, Switch & Cord Assembly For submatic motors	SFK-85

FRANKLIN MOTOR PARTS



SFK-Q

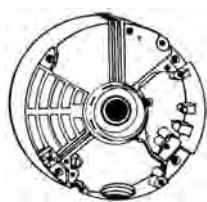

SFK-R

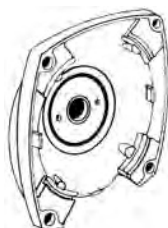

SFK-S

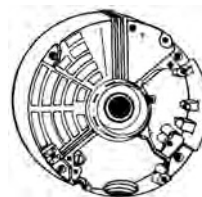

SFK-T

**PARROT
PRESS TO
STRIP IN
SCAN
sfk-u**

SFK-U

PHOTO REF	BEARING SIZE	NOTES	PART NUMBER
SFK-Q	304	6" Dia. barrel, Aluminum C-flange endbell	SFK-73
SFK-R	203	6" Dia. barrel, Opposite drive end endbell for 1/2 - 1 HP round body pump motors	SFK-74
SFK-R	203	6" Dia. barrel, Opposite drive end endbell for 1-1/2 - 3 HP round body pump motors	SFK-75
SFK-R	203	6" Dia. barrel, Opposite drive end endbell for 1/2 - 3/4 HP square flange pump motors	SFK-71
SFK-R	203	6" Dia. barrel, Opposite drive end endbell for 1 - 2 HP square flange pump motors	SFK-72
SFK-R	204	6" Dia. barrel, Opposite drive end endbell, Includes bearing	SFK-84
SFK-S	203	6" Dia. Barrel, Square flange endbell	SFK-69
SFK-S	204	6" Dia. Barrel, Square Flange endbell	SFK-70
SFK-T	203	5-1/2" Dia. barrel, Opposite drive end endbell	SFK-82
SFK-U	203	5-1/2" Dia. barrel, Drive end endbell	SFK-90

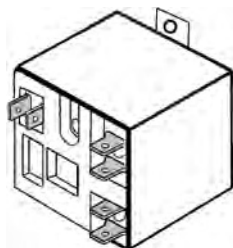

SFK-V

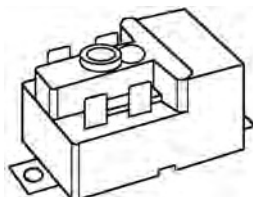

SFK-W

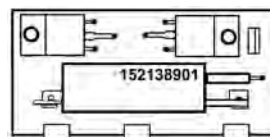

SFK-X



SFK-Y

RATING HP/VOLTAGE	COMPLETE CONTROL BOX	VOLTAGE RELAY(10)	CURRENT RELAY(1)	SOLID STATE SWITCH(1)	OVERLOAD	START CAPACITOR	RUN CAPACITOR
1/3HP / 115V	MFK-127177	LFP-155031101	4CR-52-727	152138905	MSG-59GM	BC-159-REC	N/A
1/3HP / 230V	MFK-127181	LFP-155031102	4CR-52-677	152138901	MRB-2772	BC-43M-250-REC	N/A
1/2HP / 115V	MFK-127185	LFP-155031101	4CR-52-761	152138906	MSJ-58CL	BC-250-REC	N/A
1/2HP / 230V	MFK-127189	LFP-155031102	155252102	152138902	MSG-87TL	BC-59M-250-REC(3)	RD-15-370
3/4HP / 230V	MFK-127197	LFP-155031102	4CR-52-727	152138903	MRB-2773	BC-86M-250-REC	RD-22.5-370
1 HP / 230V	MFK-126319	LFP-155031102	4CR-52-744	152138904	MSJ-61JL	BC-105M-250-REC	RD-22.5-370
1-1/2 HP / 230V	MFK-135589	LFP-155031102	N/A	N/A	-	BC-108M-250	RD-10-370
2HP / 230V	MFK-126321	LFP-155031102	N/A	N/A	-	BC-108M-250	RD-20-370
3 HP / 230V	MFK-126322	LFP-155031102	N/A	N/A	-	BC-216M-250	RD-35-370
5 HP / 230V	MFK-135269	LFP-155031102(2)	N/A	N/A	-	BC-216M-330	60 MFD @ 370VOLT(4)
5 HP / 230V		LFP-155031601	N/A	N/A	-	BC-130M-330	RD-30-370
7-1/2HP / 230V		LFP-155031601	N/A	N/A	-	400 MFD @ 330 Volt(5)	RD-45-370(6)
10HP / 230V		LFP-155031601	N/A	N/A	-	540 MFD @ 330 Volt(7)	75 MFD @ 370 Volt(8)
15 HP / 230V		LFP-155031601	N/A	N/A	-	BC-270M-330 (Qty 2)	135 MFD @ 370 Volt(9)

- (1) Solid State Switches and Current Relays can be replaced with Voltage Relay Kit, 115 Volt use LFP-305102901, 230V use LFP-305102902
- (2) Can be replaced with heavy duty relay # LFP-155031601
- (3) Some models use BC-43M-250-REC Start capacitor
- (4) Use combination 2 - RD-30-370 or 4 - RD-15-370
- (5) Use combination BC-270M-330 & BC-130M-330 or 3 BC-130M-330
- (6) Use RD-45-370 or combination RD-30-370 & RD-15-370
- (7) Use combination 2 - BC-270M-330 or 4 - BC-130M-330
- (8) Use combination 2 - RD-30-370 & 1 - RD-15-370
- (9) Use combination 3 - RD-45-370 or 2 - RD-30-370 & 1 - RD-15-370
- (10) For 208 volt applications use relay # LFP-155031-103 in place of LFP-155031102 and LFP-155031601 in place of LFP-155031601



GENERAL ELECTRIC STATIONARY SWITCHES

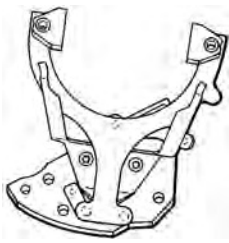

FIGURE A

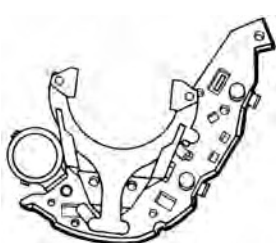

FIGURE B

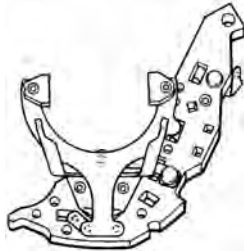

FIGURE C

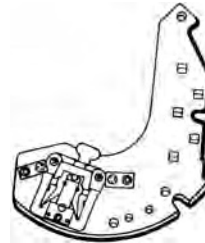

FIGURE D

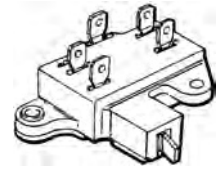

FIGURE E

PHOTO REF.	CONTACTS		MOUNTING HOLES C-T-O-C (IN.)	PLATE SIZE		SPADES		STUDS	I.D.	REMARKS	PART NUMBER
	N.O.	N.C.		WIDTH(IN.)	LENGTH(IN.)	FRONT	BACK				
A	1	-	1-1/4	-	-	-	-	2	-	-	SGE-1111
B	1	-	1-1/4 X 3-9/16	-	-	-	-	4: @ 1, 3, 4 & 5	4(1)	2(2) -	SGE-1001
C	1	-	1-1/4 X 3-9/16	-	-	-	-	5: @ 1, 3, 4, 5 & 6	2(1)	2(2) -	SGE-1021
C	1	-	1-1/4 X 3-9/16	-	-	-	-	3: @ 1, 5 & 6	2(1)	2(2) -	SGE-1069
D	1	1	1-1/4 X 3-9/16	-	-	-	-	-	-	-	SGE-752
C	1	-	1-1/4 X 3-9/16	-	-	-	-	2: @ 1 & 6	4(1)	2(2) -	SGE-832
C	1	-	1-1/4 X 3-9/16	-	-	-	-	6: @ 1, 3, 4, 5, 6 & 7	4(1)	2(2) -	SGE-876
E	-	-	1-15/16	15/16	1-7/8	-	-	5: @ 1, 2, 4, 5 & 6	3(1)	-	SGE-1076
F	2	1	1-3/4 X 3	-	-	-	-	5: @ 1, 2, 4, 5 & 8	6(1)	3(2) -	SGE-1018
F	2	1	1-3/4 X 3	-	-	-	-	5: @ 1, 2, 3, 4 & 5	4(1)	3(2) -	SGE-1019
F	2	1	1-3/4 X 3	-	-	-	-	4: @ 1, 2, 4 & 5	6(1)	3(2) -	SGE-1020
G	1	-	1-3/4 X 3	-	-	-	-	4: SINGLE @ 1 & 3, DOUBLE @ 2	5(1)	2(2) -	SGE-1026
F	2	1	1-3/4 X 3	-	-	-	-	5: @ 1, 2, 3, 4 & 5	4(1)	3(2) -	SGE-1071
G	1	-	1-3/4 X 3	-	-	-	-	2 @ 1 & 3	3(1)	2(2) -	SGE-1108
H	1	-	1-3/4 X 3	-	-	-	-	1: @ 1	5(1)	2(2) -	SGE-977
G	1	-	1-3/4 X 3	-	-	-	-	4: SINGLE @ 1 & 3, DOUBLE @ 2	3(1)	2(2) -	SGE-997
I	1	1	1-3/4 X 3-7/16	-	-	-	-	8: SINGLE @ 1, 2, 5, 6, 8 & 9, DOUBLE @ 4	4(1)	3(2) 1" KLIXON	SGE-1002
I	2	1	1-3/4 X 3-7/16	-	-	-	-	7: SINGLE @ 1, 2, 6, 7 & 9 DOUBLE @ 4	5(1)	3(2) 1" KLIXON	SGE-1004
J	1	-	1-3/4 X 3-7/16	-	-	-	-	5: @ 1, 2, 4, 5 & 7	5(1)	3(2) 1" KLIXON	SGE-1017
K	2	1	1-3/4 X 3-7/16	-	-	-	-	8: SINGLE @ 1, 2, 5, 6, 7 & 10 DOUBLE @ 4	5(1)	3(2) -	SGE-1030
K	1	1	1-3/4 X 3-7/16	-	-	-	-	6: @ 1, 2, 4, 5, 6 & 7	5(1)	3(2) 1" KLIXON	SGE-1032
K	1	1	1-3/4 X 3-7/16	-	-	-	-	8: SINGLE @ 1, 2, 5, 6, 8 & 10 DOUBLE @ 4	5(1)	3(2) -	SGE-1036
I	1	1	1-3/4 X 3-7/16	-	-	-	-	8: SINGLE @ 1, 2, 5, 6, 7 & 9 DOUBLE @ 4	4(1)	3(2) 1" KLIXON	SGE-1068
L	2	1	1-3/4 X 3-7/16	-	-	-	-	2	-	- 1" KLIXON	SGE-722
M	1	-	1-3/4 X 3-7/16	-	-	-	-	4: @ 1, 5, 6 & 7	4(1)	2(2) 1" KLIXON	SGE-846
J	2	1	1-3/4 X 3-7/16	-	-	-	-	6: @ 1, 2, 4, 5, 6 & 9	5(1)	3(2) 1" KLIXON	SGE-854
M	1	-	1-3/4 X 3-7/16	-	-	-	-	6: @ 1, 2, 3, 4, 5 & 6	2(1)	2(2) 1" KLIXON	SGE-858
M	1	-	1-3/4 X 3-7/16	-	-	-	-	2: @ 6 & 7	-	- 1" KLIXON	SGE-945
M	1	-	1-3/4 X 3-7/16	-	-	-	-	2: @ 1 & 5	2(1)	2(2) 1" KLIXON	SGE-948
M	1	-	1-3/4 X 3-7/16	-	-	-	-	4: @ 1, 2, 3, 4, 5, 6 & 7	4(1)	2(2) 1" KLIXON	SGE-973
K	1	-	1-3/4 X 3-7/16	-	-	-	-	4: @ 1, 2, 4 & 5	3(1)	3(2) 1" KLIXON	SGE-983
K	1	-	1-3/4 X 3-7/16	-	-	-	-	4: @ 1, 2, 4 & 5	5(1)	3(2) 1" KLIXON	SGE-984
I	1	-	1-3/4 X 3-7/16	-	-	-	-	6: SINGLE @ 1, 2, 5 & 6 DOUBLE @ 4	4(1)	3(2) 1" KLIXON	SGE-985
J	2	-	1-3/4 X 3-7/16	-	-	-	-	5: @ 1, 2, 4, 5 & 6	4(1)	3(2) 1" KLIXON	SGE-986
I	1	-	1-3/4 X 3-7/16	-	-	-	-	6: SINGLE @ 1, 5, 6 & 8 DOUBLE @ 4	4(1)	3(2) 1" KLIXON	SGE-987
J	1	-	1-3/4 X 3-7/16	-	-	-	-	5: @ 1, 2, 4, 5 & 7	5(1)	3(2) 1" KLIXON	SGE-988

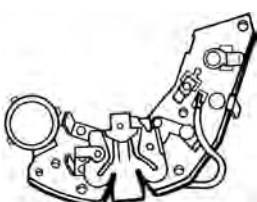

FIGURE F

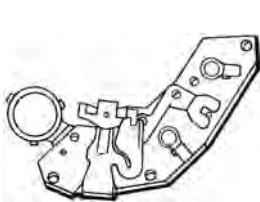

FIGURE G

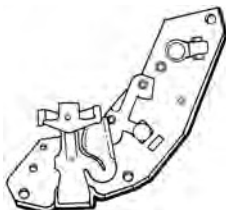

FIGURE H

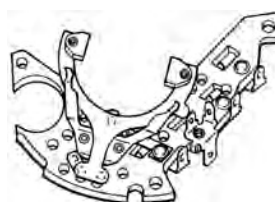

FIGURE I

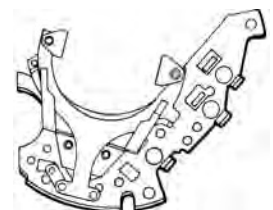

FIGURE J

GENERAL ELECTRIC STATIONARY SWITCHES

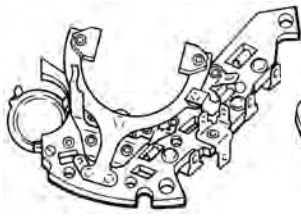

FIG: K

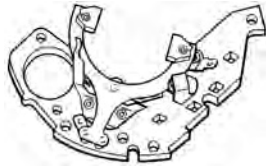

FIG: L



FIG: M

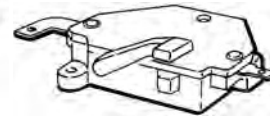

FIG: N

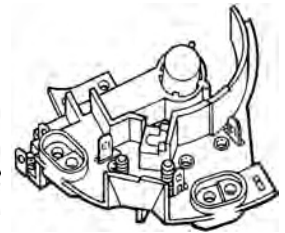

FIG: O

PHOTO REF.	CONTACTS		MOUNTING HOLES C-TO-C (IN.)	PLATE SIZE		SPADES		STUDS	I.D.	REMARKS	PART NUMBER
	N.O.	N.C.		WIDTH(IN.)	LENGTH(IN.)	FRONT	BACK				
LL	1	-	1-5/8 (1-7/8 DIAG)	1-5/8	2-3/32	-	-	2	-	-	SGE-999
N	1	-	1-7/8	-	-	-	-	2	-	-	SGE-1003
O	1	-	1-7/8 X 2-5/16	-	-	-	-	7: DOUBLE @ 1 & 3 TRIPLE @ 2	5(1)	2(2)	SGE-1116
P	1	1	1-7/8 X 2-5/16	-	-	-	-	7: DOUBLE @ 2 & 4, TRIPLE @ 3	5(1)	2(2)	SGE-1133
Q	1	-	1-5/16	-	-	-	-	3	-	-	SGE-1112
R	1	-	1-9/16 X 4	-	-	-	-	@ 1, 2, 3, 4 & 5	(1)	2(2)	SGE-1131
R	1	-	1-9/16 X 4	-	-	-	-	5: SINGLE @ T 1, 4 & 5 DOUBLE @ 3	5(1)	2(2)	SGE-1132
S	1	-	1-1/4 X 4-1/16	-	-	-	-	2	4(1)	2(2)	SGE-866
T	1	1	2	-	-	-	-	1	9(1)	-	SGE-1062
U	1	-	2	-	-	-	-	-	9(1)	-	SGE-1064
V	3	1	2	-	-	-	-	8(1)	-	-	SGE-1065
W	1	2	2	-	-	-	-	7(1)	-	-	SGE-1067
X	2	1	2 X 3-5/16	-	-	-	-	10(1)	-	-	SGE-1063
Y	3	2	2 X 3-5/16	-	-	-	-	9(1)	-	-	SGE-1066
Z	1	-	2 X 4	-	-	-	-	6: @ 1, 3, 4, 5, 6 & 7	4(1)	2(2)	1-1/4" KLX SGE-756
Z	1	-	2 X 4	-	-	-	-	6: @ 1, 2, 3, 4, 5 & 6	4(1)	2(2)	1-1/4" KLX SGE-856
Z	1	-	2 X 4	-	-	-	-	7: @ 1, 2, 3, 4, 5, 6 & 7	4(1)	2(2)	1-1/4" KLX SGE-870
Z	1	-	2 X 4	-	-	-	-	4: @ 1, 5, 6 & 7	4(1)	2(2)	1-1/4" KLX SGE-920
AA	1	-	2-1/16 X 4	-	-	-	-	1	-	4(1)	1-1/4" KLX SGE-580
AA	1	1	2-1/16 X 4	-	-	-	-	-	4(1)	-	1-1/4" KLX SGE-660
BB	1	1	2-1/16 X 4	-	-	-	-	-	-	-	SGE-695
AA	2	1	2-1/16 X 4	-	-	-	-	1	4(1)	-	1-1/4" KLX SGE-723
CC	2	1	2-1/16 X 4	-	-	-	-	6: @ 1, 2, 5, 6, 7 & 10	5(1)	3(2)	1-1/4" KLX SGE-86
CC	1	-	2-1/16 X 4	-	-	-	-	4: @ 1, 2, 5 & 6	3(1)	3(2)	1-1/4" KLX SGE-871
CC	1	-	2-1/16 X 4	-	-	-	-	7: SINGLE @ 1, 2, 5, 6 & 8 DOUBLE @ 4	5(1)	3(2)	1-1/4" KLX SGE-944
CC	1	1	2-1/16 X 4	-	-	-	-	6: @ 1, 2, 5, 6, 8 & 10	5(1)	3(2)	1-1/4" KLX SGE-989
CC	1	1	2-1/16 X 4	-	-	-	-	8: @ 1, 2, 5, 6, 8 & 10 DOUBLE @ 4	5(1)	3(2)	1-1/4" KLX SGE-990
CC	2	1	2-1/16 X 4	-	-	-	-	8: @ 1, 2, 5, 6, 8 & 10 DOUBLE @ 4	5(1)	3(2)	1-1/4" KLX SGE-991
DD	1	-	2-1/8 (Slotted)	-	2-1/2	2-1/2	-	-	-	13/16"	SGE-246
EE	1	-	2-3/16	1	2-5/8	-	-	2	-	-	SGE-537
EE	1	1	2-3/16	1	2-5/8	-	-	3	-	-	SGE-975
FF	-	-	2-5/8	1-13/32	3-1/8	-	-	3: @ 1-RED, 2-BLU & 3-BLK	5(1)	-	SGE-873
GG	1	1	3	2-1/4	3-3/8	-	-	-	-	-	SGE-677
HH	1	-	3-5/8	-	-	-	-	3: @ 11, 14 & 15	9(1)	2(2)	SGE-1144
HH	2	1	3-5/8	-	-	-	-	3: @ 11, 14 & 15	13(1)	2(2)	SGE-1147
II	1	1	4-1/2	2	5-3/8	-	-	-	-	1-1/4"	SGE-13
II	1	-	4-1/2	2	5-3/8	-	-	-	-	1-1/4"	SGE-248
JJ	1	-	7/8 X 2-5/8	1-9/16	3	-	-	-	-	-	SGE-20
KK			1	1-7/16	1-13/16	-	-	Doubles @ 1,7,3,6,5,4,2	-	-	Form T & V Appl. Mtr. SGE-1011
KK			1	1-7/16	1-13/16	-	-	Single @ 6,7 Double @ OR,Wht,Blu	-	-	Form T&V Appl. Mtr. SGE-1015
KK			1	1-7/16	1-13/16	-	-	Doubles @ 7,3,9,5,4,2,8	-	-	Form T & V Appl. Mtr. SGE-1016
KK			1	1-7/16	1-13/16	-	-	Doubles @ 3,,5,9,7,1,2,8,4,6	-	-	Form T & V Appl. Mtr. SGE-1022

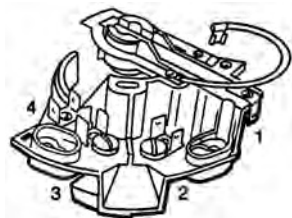

FIG: P

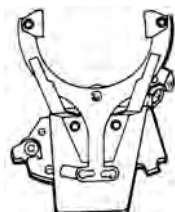

FIG: Q

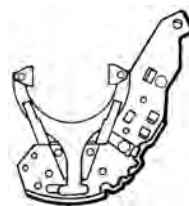

FIG: R

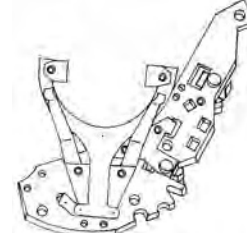

FIG: S

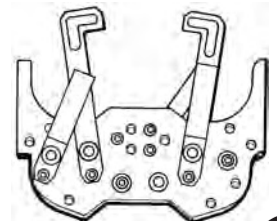

FIG: T

GENERAL ELECTRIC STATIONARY SWITCHES

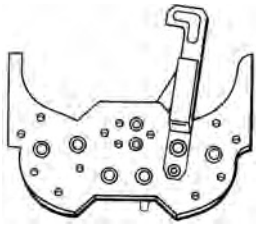

FIG: U

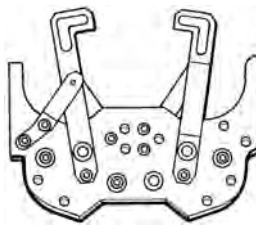

FIG: V

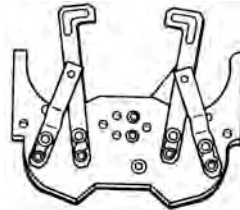

FIG: W

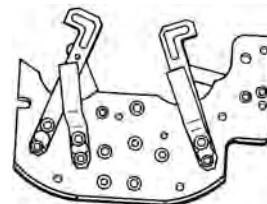

FIG: X

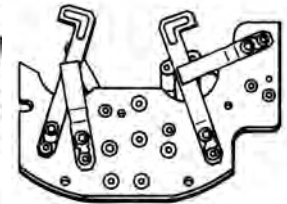

FIG: Y

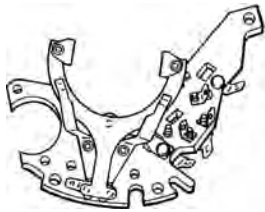

FIG: Z

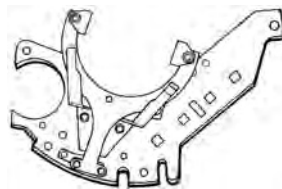

FIG: AA



FIG: BB

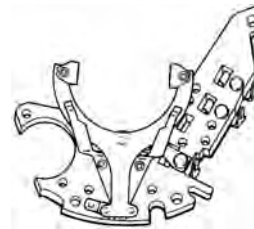

FIG: CC

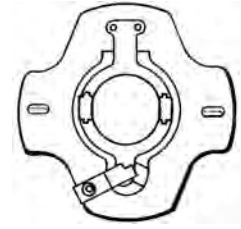

FIG: DD

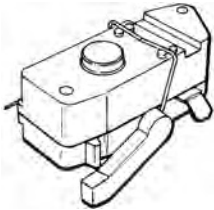

FIG: EE

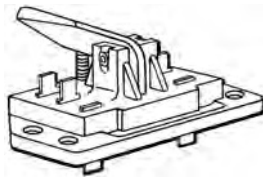

FIG: FF

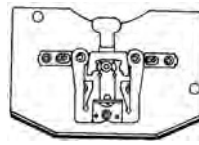

FIG: GG

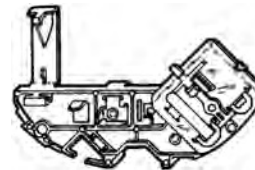

FIG: HH

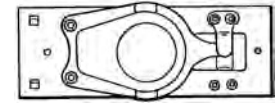

FIG: II

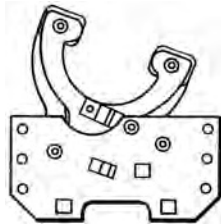

FIG: JJ

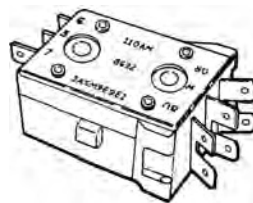

FIG: KK

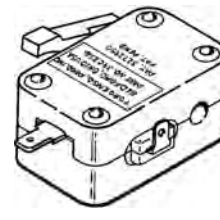

FIG: LL

PHOTO REF.	CONTACTS		MOUNTING HOLES C-TO-C (IN.)	PLATE SIZE		SPADES		STUDS	I.D.	PART REMARKS	PART NUMBER
	N.O.	N.C.		WIDTH(IN.)	LENGTH(IN.)	FRONT	BACK				
KK				1	1-7/16		1-13/16	Doubles @ 1, Single @ Blank Double @ 3, Single @ Blank Doubles @ 9,5,4,2,8	Form T & V Appl. Mtr.		SGE-1075 SGE-1105 SGE-1148 SGE-1149 SGE-1154
3NEW											
3NEW											
3NEW											
3NEW											

GENERAL ELECTRIC - WASHERS



DESCRIPTION	REMARKS	PART NUMBER
Cushion Washer	I.D. 1/2" • O.D. 13/16" • Thickness 1/16" • Used on Form G 30 Frame Motors	SGE-611
Cushion Washer	I.D. 5/8" • O.D. 1/16" • Thickness 1/16" • Used on Form G 40 Frame Motors	SGE-612
Cup Washer	I.D. 17/32" • O.D. 7/8" • Thickness 1/8" • Used on Form G 30 Frame Motors	SGE-613
Cushion Washer	I.D. 21/32" • O.D. 1" • Thickness 1/8" • Used on Form G 40 Frame Motors	SGE-614

SUMP PUMP SWITCHES

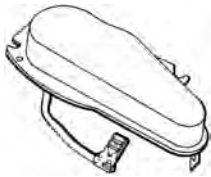

FIG: MM



FIG: NN

PHOTO FIG.	REMARKS	PART NUMBER
MM	Mounting Holes 2-13/16" Weight Operated	SGE-753
NN	Mounting Holes-2-13/16" Float Operated	SGE-754

CAPACITOR COVERS

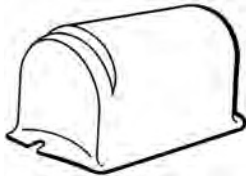

REMARKS	PART NUMBER
Capacitor Size 1-7/16" X 4-3/8"	SGE-584
Capacitor Size 2-1/16" X 3-3/8"	SGE-585
Capacitor Size 2-1/16" X 4-3/8"	SGE-586
Capacitor Size 2-9/16" X 4-3/8"	SGE-587

CAPACITOR AND SWITCH COVER



REMARKS	PART NUMBER
O.D. 5-5/8"-56 Frame- Single speed Pool and Jet pumps	SGE-1140
O.D. 5-5/8"-56 Frame- Two speed Pool and Jet pumps	SGE-1141

RELAYS

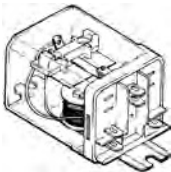

REMARKS	OLD GE NUMBER	NEW GE NUMBER	PART NUMBER
Single Pole Double Throw	976B357AA5	121A336P2	SGE-857
Single Pole Double Throw	976B357AA1	121A336P8	SGE-585

END BELLS



FIG: OO

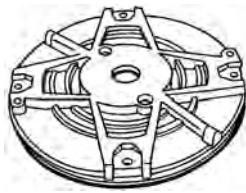

FIG: PP



FIG: QQ

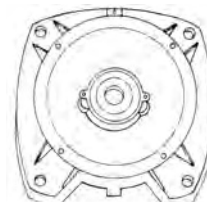

FIG: RR

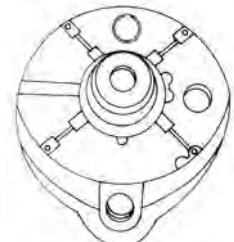

FIG: SS

PHOTO FIG.	DESCRIPTION	REMARKS	PART NUMBER
OO	ENDBELL	O.D. 5-9/16"-Bore 1/2" • Hub O.D. 1 3/4" • For 39 Frame KCP & KSP • Complete with Sleeve Bearing Enclosed w/Hub	SGE-1073
OO	ENDBELL	O.D. 5-9/16"-Bore 1/2" • Hub O.D. 1 3/4" • For 39 Frame KCP & KSP • Complete with Sleeve Bearing Open No Hub	SGE-1074
OO	ENDBELL D.E.	O.D. 5-9/16"-Bore 1/2" • Hub O.D. 1 3/4" • For 39 Frame KCP & KSP • Complete with Sleeve Bearing Open W/ Hub	SGE-1072
QQ	ENDBELL D.E.	O.D. 5-5/8"-56 C Flange • Open • Uses 203 Ball Bearing • Rabbitt-5.47	SGE-1137
PP	ENDBELL D.E.	O.D. 5-5/8"-56 Frame • Open • Uses 203 Ball Bearing • Rabbitt-5.47	SGE-1138
RR	ENDBELL D.E.	O.D. 5-5/8"-56 D Flange • For Sta-rite Pump • Uses 203 Ball Bearing • Rabbitt-5.47	SGE-1139
QQ	ENDBELL D.E.	Used on new style GE pump motors. Uses 204 Bearing.	SGE-1159
SS	ENDBELL O.D.E.	O.D. 5-5/8"-56 Frame • For 2 speed pool motors • Uses 203 Ball Bearing • Rabbitt-5.47	SGE-1136

END CAPS • SLINGERS



FIG: TT



FIG: UU



FIG: VV

PHOTO FIG.	DESCRIPTION	REMARKS	PART NUMBER
TT	End Cap	O.D. 1-1/2" • Fits in 1-3/8" housing • For Opposite Pulley End	SGE-601
TT	End Cap	O.D. 1-3/4" • Fits in 1-29/32" housing • For Opposite Pulley End	SGE-602
TT	End Cap	O.D. 1-1/2" • I.D. 1/2" • Fits housing for 1/2" Shaft • For Drive End	SGE-605
TT	End Cap	O.D. 1-3/4" • I.D. 5/8" • Fits in 19/32" housing for 5/8" Shaft • For Drive End	SGE-606
UU	Rainshield	I.D. 5-5/8" • O.D. 6-5/16" • Plastic • For Pool and Jet Pump Motors	SGE-1142
VV	Slinger	I.D. 1/2" • Used on 30 frame form G motors	SGE-596
VV	Slinger	I.D. 5/8" • Used on 40 frame form G motors	SGE-597

MOUNTING BRACKETS



FIG: WW



FIG: XX



FIG: YY



FIG: ZZ

PHOTO FIG.	DESCRIPTION	REMARKS	PART NUMBER
WW	Lug Mounting Adaptor	Will fit 5-1/2" Motors (NEMA 48 Frame) • 3 Lug "39 AL"	MTG-8020
XX	Length Adaptor	Motor Length Adaptor for "29 Frame" Motors, Includes Frame, Mount Ring, Adaptor Rings, Mounting Nuts	MTG-8087
YY	"Torsion-Flex" Adaptor	"Torsion Flex" Adaptor for 5" and 5 1/2" Diameter Motors • Blower Dia. 9" and 10" • Kits consists of: Torsion-Flex Adaptor Band • 3 Spacers with Adhesive Retainer • 1 Screw and Nut	MTG-8051
ZZ	Aluminum Rings	O.D. 2-1/4" • 4 per set • Use two overlapping rings to convert 2-1/4" to 2-1/2" Dia. - 48 Frame	MTG-8031

MOUNTING CLAMPS



FIG: AAA



FIG: BBB



FIG: CCC

PHOTO FIG.	DESCRIPTION	REMARKS	PART NUMBER
AAA	Latch	Width 3/8" • Length 1-43/64" • For GE 21/29 Frame Motors	SGE-1008
BBB	Locking Clip	I.D. 1/2" • Number on clip 8	SGE-616
BBB	Locking Clip	I.D. 1/2" • Number on clip 7	SGE-617
BBB	Locking Clip	I.D. 5/8" • Number on clip 1	SGE-618
BBB	Locking Clip	I.D. 5/8" • Number on clip 2	SGE-619
BBB	Locking Clip	I.D. 5/8" • Number on clip 3	SGE-620
CCC	Mounting Clamp	Width 3/8" • Length 2-13/16"	SGE-385
CCC	Mounting Clamp	Width 9/32" • Length 2-1/16" • For GE 11 Frame Motors	MTG-8092
CCC	Mounting Clamp	Width 23/64" • Length 2-1/4"	SGE-685
CCC	Mounting Clamp	Width 7/16" • Length 2-9/16"	SGE-717
CCC	Mounting Clamp	Width 23/64" • Length 2-1/4"	SGE-718
CCC	Mounting Clamp	Width 23/64" • Length 2-3/8"	MTG-8096
CCC	Mounting Clamp	Width 23/64" • Length 2-25/64" • For GE 29 Frame Motors	SGE-1028

BASES GE 39 FRAME MOTORS

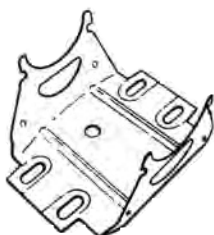

REMARKS	PART NUMBER	REMARKS	PART NUMBER
C-to C 4.14" • Shaft Height 3-1/2" • Base #-AN2	MTG-8052	C-to C 5.39" • Shaft Height 3-1/2" • Base #-AN7	MTG-8057
C-to C 4.39" • Shaft Height 3-1/2" • Base #-AN3	MTG-8053	C-to C 5.64" • Shaft Height 3-1/2" • Base #-AN8	MTG-8058
C-to C 4.64" • Shaft Height 3-1/2" • Base #-AN4	MTG-8054	C-to C 6.64" • Shaft Height 3-1/2" • Base #-AN9	MTG-8059
C-to C 4.89" • Shaft Height 3-1/2" • Base #-AN5	MTG-8055	C-to C 6.14" • Shaft Height 3-1/2" • Base #-AN10	MTG-8010
C-to C 5.14" • Shaft Height 3-1/2" • Base #-AN6	MTG-8056		
All Bases Shipped with Clips			

TERMINALS • METAL WASHERS • TERMINAL STUDS

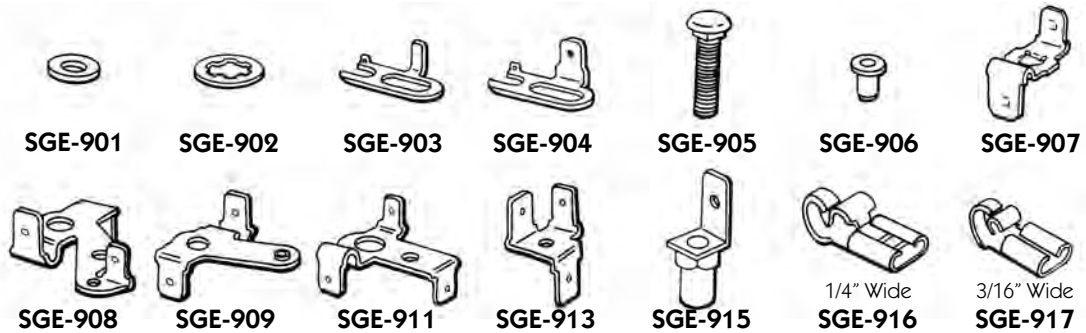

SHAFT ADAPTORS



FIG: DDD

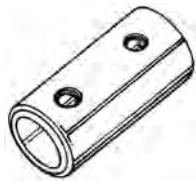

FIG: EEE

PHOTO FIG.	REMARKS	DESCRIPTION	PART NUMBER
DDD	Ground Steel Shaft Adaptor	I.D. 1/4"; • O.D. 5/16"	MTG-8201
DDD	Ground Steel Shaft Adaptor	I.D. 1/4"; • O.D. 3/8"	MTG-8202
DDD	Ground Steel Shaft Adaptor	I.D. 1/4"; • O.D. 1/2"	MTG-8205
DDD	Ground Steel Shaft Adaptor	I.D. 5/16"; • O.D. 3/8"	MTG-8203
DDD	Ground Steel Shaft Adaptor	I.D. 5/16"; • O.D. 1/2"	MTG-8206
DDD	Ground Steel Shaft Adaptor	I.D. 3/8"; • O.D. 7/16"	SGE-849
EEE	Ground Steel Shaft Adaptor	I.D. 3/8"; • O.D. 1/2"	MTG-8207
DDD	Ground Steel Shaft Adaptor	I.D. 7/16"; • O.D. 1/2"	MTG-8208
DDD	Ground Steel Shaft Adaptor	I.D. 7/16"; • O.D. 5/8"	MTG-8209
DDD	Ground Steel Shaft Adaptor	I.D. 1/2"; • O.D. 5/8"	MTG-8210
DDD	Ground Steel Shaft Adaptor	I.D. 1/2"; • O.D. 5/8" • Key Included	MTG-8215
EEE	Ground Steel Shaft Adaptor	I.D. 1/2"; • O.D. 3/4" • 2 Per Set	MTG-8112
DDD	Ground Steel Shaft Adaptor	I.D. 1/2"; • O.D. 3/4"	MTG-8211
DDD	Ground Steel Shaft Adaptor	I.D. 5/8"; • O.D. 3/4" • Key Included	MSA-58-34

WICKING AND OILER

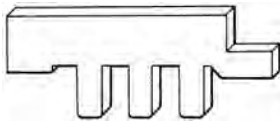

FIG: FFF



FIG: GGG

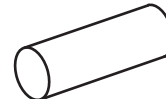

FIG: HHH



FIG: III

PHOTO FIG.	DESCRIPTION	REMARKS	PART NUMBER
FFF	Finger Wick	Length 4-1/2" • Thickness 1/8" • Used on Form G 30 Frame Motors	SGE-590
FFF	Finger Wick	Length 5-1/4" • Thickness 1/8" • Used on Form G 30 Frame Motors	SGE-591
GGG	Straight Wick	Length 5" • Width 21/32" • Thickness 11/32" Used on Form G 30 Frame Motors	SGE-592
GGG	Straight Wick	Length 6" • Width 3/4" • Thickness 11/32" Used on Form G 40 Frame Motors	SGE-593
HHH	Cylindrical Wick	Length 3/4" • Dia. 9/32" • Used on Form G 30 Frame Motors	SGE-594
HHH	Cylindrical Wick	Length 1" • Dia. 5/16" • Used on Form G 30 Frame Motors	SGE-595
III	Oiler	Length 7/16" • Plastic • Fits 3/16" Hole • Used on Form G Motors	SGE-600

DC PARTS IDENTIFICATION HANDBOOK

This quick selection handbook is designed to provide a quick method of identifying standard parts for GE DC motors. This listing deals primarily with brush holders brush holder spring and brushes. The parts listed are for standard motors that have a non standard motor, or are not sure if the parts you have identified are correct, please supply us with the complete model number and/or serial number of the motor you are repairing.

This handbook covers the motors that we receive 75 - 80% of or requests on. As we gather more information we will add additional listings to this handbook. To identify parts for the motor you are repairing, determine which series motor you have then go to the appropriate page to get the parts listing, (i.e. motor model 5CD144WA801A800) look for the model structure that begins with 5CD144 ... this is a Kinamatic II proceed to page 5 of this handbook for a listing of the brush holder, brush holder spring and standard brushes.

BREAKDOWN OF GE MODEL NUMBERS

MODEL STRUCTURE *	EXAMPLE MODEL	MOTOR SERIES	PAGE
34LNNN	34B615	Motor	N/A
36LNNNNNN	36X958083	Motor	N/A
5AMNNNLNN	5AM602B23	Amplidyne	N/A
5ANNNNLNLNN	5AN102B1G02	Motor	N/A
5BTNNNNLN	5BT1328B7	Electric Vehicle Motors	N/A
5BTNNNNLN	5BT2379M2	Electric Vehicle Motors	N/A
5BYNNNNLNNN	5BY435A65	Low Inertia	N/A
5CD122LLNNNL	5CD122HE001B	Kinamatic II K3 (CD146 Frame)	5
5CD123LLNNNL	5CD123WE001B	Kinamatic II K3 (CD148 Frame)	5
5CD124LLNNNL	5CD124TP001B	Kinamatic II (CD149 Frame)	5
5CD125LLNNNL	5CD125WE001B	Kinamatic II (CD1412 Frame)	5
5CD142LLNNNLNNN	5CD142FE012B008	Kinamatic II (CDL182AT Frame)	5
5CD143LLNNNLNNN	5CD143LC007B021	Kinamatic II (CD186AT Frame)	5
5CD144LLNNNLNNN	5CD144WA801A800	Kinamatic II (CDL186AT Frame)	5
5CD145LLNNNLNNN	5CD145UA030B001	Kinamatic II (CD189AT Frame)	5
5CD14LNNLNNNNNNN	5CD14E03A36630	Kinamatic II (CD180AT Frame)	5
5CD152LLNNNLNNN	5CD152JA001A001	Kinamatic II (CD218AT Frame)	5
5CD153LLNNNLNNN	5CD153RA004B001	Kinamatic II (CD219AT Frame)	5
5CD154LLNNNLNNN	5CD154TA003B001	Kinamatic II (CD2110AT Frame)	5
5CD163LLNNNLNNN	5CD163SA001A001	Kinamatic II (CD258AT Frame)	5
5CD164LLNNNLNNN	5CD164MA055A001	Kinamatic II (CD259AT Frame)	5
5CD173LLNNNLNNN	5CD173VA018A009	Kinamatic II (CD287AT Frame)	5
5CD174LLNNNLNNN	5CD174RA001A001	Kinamatic II (CD288ATFrame)	5
5CD183LLNNNLNNN	5CD183KA001A001	Kinamatic II (CD327AT Frame)	5
5CD184LLNNNLNNN	5CD184TA013A026	Kinamatic II (CD328AT Frame)	5
5CD192LLNNNLNNN	5CD192NA027A031	Kinamatic II (CD365AT Frame)	5
5CD193LLNNNLNNN	5CD193PA003A013	Kinamatic II (CD366AT Frame)	5
5CD194LLNNNLNNN	5CD194MA001A001	Kinamatic II (CD360AT Frame)	5
5CD203LLNNNLNNN	5CD203PA001A001	Kinamatic II (CD407AT& CDL407AT Frame)	6
5CD204LLNNNLNNN	5CD204PA086A010	Kinamatic II (CD409AT & CDL409AT Frame)	6
5CD222LLNNNLNNN	5CD222LA001A001	Kinamatic II (CD504AT & CDL504AT Frame)	6
5CD223LLNNNLNNN	5CD223SA074B001	Kinamatic II (CD506AT & CDL506AT Frame)	6
5CD224LLNNNLNNN	5CD224TA032B012	Kinamatic II (CD508AT & CDL508AT Frame)	6
5CD226LLNNNLNNN	5CD226SA002B003	Kinamatic II (CD5010ATZ Frame)	N/A
5CD256LNNN	5CD256G177	Kinamatic I	N/A
5CD25LNNLNNNNNNN	5CD25D26G001513	CD5000 - CD9000 Series	9
5CD362LLNNNLNNN	5CD362MA001A001	Kinamatic II (CD2512AT Frame)	6
5CD363LLNNNLNNN	5CD363NA001A001	Kinamatic II (CD2513AT Frame)	6
5CD372LLNNNLNNN	5CD372MA001A001	Kinamatic II (CD2812AT Frame)	6
5CD373LLNNNLNNN	5CD373PA002A001	Kinamatic II (CD2813AT Frame)	6
5CD432LLNNNLNNN	5CD432EA001C800	CD4000	10
5CD505LNNN	5CD505G329	Kinamatic I	N/A
5CD684LNNNLL	5CD684E143BE	CD580 -CD680 Series	10
5CDS326LNNN	5CDS326G230	Generator	N/A
5CYNNNNLN	5CY1031E1	Roll Grinder	N/A
5GTENNLNNLN	5GTE20D03A1	Motor	N/A
5MD020LNNNNNLL	5MD020D114100SD	Mill Duty 600 Frame	2 - 3
5MD824LNN	5MD824A3	Excavator Mill Duty MDP800 Frame	4

* N = Number L = Letter

N/A Indicates not available at time of printing

GENERAL ELECTRIC MOTOR PARTS

GE MILL DUTY 600 FRAME PARTS IDENTIFICATION

When identifying parts for MD600 motors, the frame size of the motor needs to be determined as well as the armature voltage and type of brush spring (constant pressure or clock spring).

The Number In Parentheses after each part number indicates quantity per motor.

- 1.) Motor Frame Size -- (MD600, MD602, through MD618)
- 2.) Armature Voltage (230 Volt Or 550 Volt)
- 3.) Spring Type (Constant Pressure or Coil / Clock Spring)
(Constant pressure brush holders are interchangeable with coil spring brush holders.)

MD600 CONSTANT PRESSURE TYPE SPRING -- 230 VOLT				
FRAME	BRUSH HOLDER (RH)	BRUSH HOLDER (LH)	BRUSH HOLDER SPRING	BRUSH
MD602	SGE-5015 (1)	SGE-5016 (1)	SGE-5112 (4)	337B696-P02 (4)
MD603	SGE-5015 (1)	SGE-5016 (1)	SGE-5112 (4)	337B696-P02 (4)
MD604	SGE-5021 (1)	SGE-5022 (1)	SGE-5108 (4)	337B696-P03 (4)
MD606	SGE-5023 (1)	SGE-5024 (1)	SGE-5100 (4)	337B696-P04 (4)
MD608	SGE-5017 (1)	SGE-5018 (1)	SGE-5100 (4)	337B696-P05 (4)
MD610	SGE-5025 (1)	SGE-5026 (1)	SGE-5100 (4)	337B696-P08 (6)
MD612	SGE-5011 (2)	Same	SGE-5100 (6)	337B696-P07 (6)
MD614	SGE-5014 (4)	Same	SGE-5100 (16)	337B696-P08 (16)
MD616	GE-5019 (4)	Same	SGE-5100 (16)	337B696-P07 (16)
MD618	SGE-5020 (4)	Same	SGE-5100 (16)	337B696-P09 (16)
MD600 COIL / CLOCK TYPE SPRING -- 230 VOLT				
FRAME	BRUSH HOLDER (RH)	BRUSH HOLDER (LH)	BRUSH HOLDER SPRING	BRUSH
MD602	SGE-5028 (1)	6748708G02 (1)	N/A	6709783-P01 (4)
MD603	SGE-5028 (1)	6748708G02 (1)	N/A	6709783-P01 (4)
MD604	SGE-5030 (1)	SGE-5031 (1)	N/A	6709786-P01 (4)
MD606	SGE-5038 (1)	SGE-5039 (1)	N/A	8809716-P01 (4)
MD608	SGE-5032 (1)	SGE-5033 (1)	N/A	8809563-P01 (4)
MD610	SGE-5034 (1)	SGE-5035 (1)	N/A	8809552-P01 (6)
MD612	SGE-5027 (2)	Same	N/A	6709764-P01 (6)
MD614	SGE-5036 (4)	Same	N/A	8809552-P01 (16)
MD616	SGE-5037 (4)	Same	N/A	6709764-P01 (16)
MD618	SGE-5029 (4)	Same	N/A	6709776-P01 (16)
MD600 CONSTANT PRESSURE TYPE SPRING -- 550 VOLT				
FRAME	BRUSH HOLDER (RH)	BRUSH HOLDER (LH)	BRUSH HOLDER SPRING	BRUSH
MD602	No Constant Pressure Replacement			
MD603	SGE-5016 (1)	SGE-5015 (1)	SGE-5112 (4)	337B696-P02 (4)
MD604	SGE-5016 (1)	SGE-5015 (1)	SGE-5112 (4)	337B696-P02 (4)
MD606	SGE-5022 (1)	SGE-5021 (1)	SGE-5108 (4)	337B696-P03 (4)
MD608	SGE-5024 (1)	SGE-5023 (1)	SGE-5100 (4)	337B696-P04 (4)
MD610	SGE-5018 (1)	SGE-5017 (1)	SGE-5100 (4)	337B696-P05(4)
MD612	Obsolete	Obsolete	SGE-5100 (4)	337B696-P05 (4)
MD614	Obsolete	Obsolete	SGE-5100 (8)	337B696-P05 (8)
MD616	Obsolete	Obsolete	SGE-5100(12)	337B696-P08 (12)
MD618	SGE-5014 (4)	Same	SGE-5100(16)	337B696-P08 (16)
MD600 COIL / CLOCK TYPE SPRING -- 550 VOLT				
FRAME	BRUSH HOLDER (RH)	BRUSH HOLDER (LH)	BRUSH HOLDER SPRING	BRUSH
MD602	Obsolete	Obsolete	N/A	8807309-P01 (4)
MD604	SGE-5028 (1)	Obsolete	N/A	6709783-P01(4)
MD606	SGE-5030 (1)	SGE-5031 (1)	N/A	6709786-P01 (4)
MD608	SGE-5038 (1)	SGE-5039 (1)	N/A	8809716-P01 (4)
MD610	SGE-5032 (1)	SGE-5033 (1)	N/A	8809563-P01 (4)
MD612	Obsolete	Obsolete	N/A	8809563-P01 (4)
MD614	Obsolete	Obsolete	N/A	8809563-P01 (8)
MD616	Obsolete	Obsolete	N/A	8809522-P01 (12)
MD618	SGE-5036 (4)	Same	N/A	8809522-P01 (16)

The parts listed are standard parts for that series motor, if you have a custom or non standard motor supply us with the complete motor number and we will be glad to identify the parts for you.

GE MILL DUTY 600 FRAME PARTS IDENTIFICATION

MD600 ARMATURE PARTS COMMON TO ALL 230V MOTORS						
FRAME	ARMATURE COILS	INSULATION SET	EQUALIZER COIL	COMMUTATOR	SHAFT	FAN
MD602	6739323G01	6739363ABG01	None	764979G01	6739383G02	6739486001
MD603	8832060G01	36C695833AAG01	None	8822219G01	8832390G02	8832383001
MD604	6739295G01	36C695834AAG01	None	8822635G01	8832022G03	8832027001
MD606	88320419G01	36C695835AAG01	None	8822951G01	8832307G02	8832312001
MD608	6739487G01	36C695836AAG01	None	8822696G01	8832542G01	8832100001
MD610	6739255G01	36C695837AAG01	None	8822852G01	8832543G01	8832166001
MD612	6739237G01	36C695838AAG01	None	6727740G01	8832544G01	6739459001
MD614	8832010G01	36C695839AAG01	8832919G01	8822836G01	8832545G01	8832138001
MD616	8832037G01	428C345G01	8832924G01	8822910G01	8832546G01	8832260001
MD618	6739341G01	8842626ABG01	8832923G01	6739413G01	8832547G01	6739496001
MD620	428C588G01	428C587ABG01	None	None	None	None
MD622	428C564G01	428C562ABG01	None	None	None	None
MD600 STATOR PARTS COMMON TO ALL 230V MOTORS						
SERIES COIL FRAME	SHUNT COIL & POLE PIECE	COMPOUND COIL & POLE PIECE	COMM. COIL & POLE PIECE	STAB. SHUNT & POLE PIECE	COIL & POLE	BEARING
MD602	6739325G65	6739326G65	6739354G65	6739324G61	8832779G65	NJ310-G1
MD603	8832062G65	8832064G65	8832063G65	8832061G61	8832066G65	NJ310-G1
MD604	6739297G65	6739298G65	6739479G65	6739296G61	6739481G65	NJ313-G1
MD606	8832051G65	8832053G65	8832052G65	8832050G61	8832055G65	NJ315-G1
MD608	6739489G65	6739491G65	6739490G65	6739488G61	6739493G65	NJ317-G1
MD610	6739257G65	6739258G65	6739482G65	6739256G61	6739482G65	NJ319-G1
MD612	6739239G65	6739243G65	6793241G65	6739238G61	6739247G65	NJ321-G1
MD614	8832012G65	8832016G65	8832014G65	8832011G61	8832020G65	NJ323
MD616	8832039G65	8832043G65	8832041G65	8832038G61	8832047G65	NJ326
MD618	6739343G65	6739345G65	6739344G65	6739342G61	6739347G65	NJ328
MD620	428C348G65	8842697G65	428C308G65*	428C333G65	None	8832705-012
MD622	None	None	8851734G65	88424001G65**	None	8832705-013

* Non Compensated ** Compensated

MD600 CABLE BUSHINGS COMMON TO ALL 230V MOTORS					
FRAME	SERIES MOTOR	SHUNT MOTOR BUSHINGS		COMPOUND MOTOR BUSHINGS	
	ALL BUSHINGS	FIELD	ARMATURE	FIELD	ARMATURE
MD602	SGE-5811 (8)	SGE-5811 (4)	SGE-5811 (4)	SGE-5811 (4)	SGE-5811 (4)
MD603	SGE-5811 (8)	SGE-5811 (4)	SGE-5811 (4)	SGE-5811 (4)	SGE-5811 (4)
MD604	SGE-5812 (8)	SGE-5811 (4)	SGE-5812 (4)	SGE-5811 (4)	SGE-5812 (4)
MD606	SGE-5813 (8)	SGE-5811 (4)	SGE-5813 (4)	SGE-5811 (4)	SGE-5813 (4)
MD608	SGE-5813 (8)	SGE-5811 (4)	SGE-5813 (4)	SGE-5811 (4)	SGE-5813 (4)
MD610	41B533331-005 (8)	SGE-5811 (4)	41B533331-005 (4)	SGE-5811 (4)	41B533331-005 (4)
MD612	41B533331-009 (8)	SGE-5811 (4)	41B533331-009 (4)	SGE-5811 (4)	41B533331-009 (8)
MD614	41B533331-009 (8)	SGE-5811 (4)	41B533331-009 (4)	SGE-5811 (4)	41B533331-009 (8)
MD616	41B533331-011 (8)	41B533331-025 (4)	41B533331-011 (4)	41B533331-025 (4)	41B533331-011 (8)
MD618	41B533331-010 (8)	41B533331-025 (4)	41B533331-010 (4)	41B533331-025 (4)	41B533331-010 (8)
MD620		SGE-5812 (6)	41A236629AA001 (6)	SGE-5812 (6)	

The parts listed are standard parts for that series motor, if you have a custom or non standard motor supply us with the complete motor number and we will be glad to identify the parts for you.

GE MILL DUTY 800 FRAME PARTS IDENTIFICATION

When identifying parts for MD800 series motors, you need to determine the motor frame size.

Motor frame size can be determined by examining the two digits that follow the 5MD designation.

I.E. 5MD020 = MD802, 5MD060 = MD806, 5MD180 = MD818.

MD800 SERIES MOTORS - BRUSH HOLDER PARTS							
TYPE	EXAMPLE	BRUSH HOLDER	QTY	BRUSH SPRING	QTY	BRUSH	QTY
MD802	5MD020D100000AB	SGE-5003	4	SGE-5105	4	SGE-5227	4
MD803	5MD030D100000AB	SGE-5004	4	SGE-5105	4	SGE-5228	4
MD804	5MD040D100000AB	SGE-5005	4	SGE-5107	4	SGE-5238	4
MD806	5MD060D100000AB	SGE-5006	4	SGE-5108	4	SGE-5229	4
MD808	5MD080D100000AB	SGE-5006	6	SGE-5102	6	SGE-5229	6
MD810	5MD100D100000AB	SGE-5000	8	SGE-5102	8	SGE-5224	8
MD812	5MD120D100000AB	SGE-5001	8	SGE-5103	8	SGE-5225	8
MD814	5MD140D100000AB	SGE-5001	12	SGE-5103	12	SGE-5225	12
MD816	5MD160D100000AB	SGE-5001	16	SGE-5103	16	SGE-5225	16
MD818	5MD180D100000AB	SGE-5002	16	SGE-5104	16	SGE-5226	16
MD800 ARMATURE PARTS COMMON TO ALL 230V MOTORS							
FRAME	ARMATURE COILS	INSULATION SET	EQUALIZER COIL	COMMUTATOR	SHAFT	FAN	
MD802	SGE-5406	36A164190AAG01	None	36B468970AA001	36B465450AAG01	36A164070CA001	
MD803	SGE-5407	36A164191AAG01	None	36B468971AA001	36B465451AAG01	36A164071CA001	
MD804	SGE-5408	36A164192AAG01	None	36B468972AA001	36B465452AAG01	36A164072CA001	
MD806	SGE-5409	36A164193AAG01	None	36B468973AA001	36B465453AAG01	36A164072CA001	
MD808	SGE-5400	36A164194AAG01	None	36B468974AA001	36B465454AAG01	36A164074CB001	
MD810	SGE-5401	36A164195AAG01	None	36B468975AA001	36B465455AAG01	36A164074CA001	
MD812	SGE-5402	36A164196AAG01	None	36B468976AA001	36B465456AAG01	36A164076CA001	
MD814	SGE-5403	36A164197AAG01	36A164177AB001	36A164087AAG01	36B465457AAG01	36A164077CA001	
MD816	SGE-5404	36A164198AAG01	36A164178AB001	36A164088AAG01	36B465458AAG01	36A164078CA001	
MD818	SGE-5405	36A164199AAG01	36A164179AB001	36A164089AAG01	36B465459AAG01	36A164079CA001	
MD800 STATOR PARTS COMMON TO ALL 230V MOTORS							
FRAME	SERIES COIL & POLE PIECE	SHUNT COIL & POLE PIECE	COMPOUND COIL & POLE PIECE	COMM. COIL & POLE PIECE	STAB. SHUNT COIL & POLE	BEARING	
MD802A	36A164400TCG01	36A164400AGG01	36A164400JGD01	36A164360BAG01	36A164400JRG01	NJ310-G1	
MD802B	36A164400TDG01	SGE-5314	36A164400JEG01	36A164360BAG01	36A164400JRG01	NJ310-G1	
MD802C	36A164400TEG01	SGE-5314	36A164400JFG01	SGE-5308	36A164400JRG01	NJ310-G1	
MD803	36A164401TBG01	SGE-5316	36A164401JCG01	36A164361BAG01	36A164401JRG01	NJ311-G1	
MD804	36A164402TBG01	SGE-5315	36A164402JCG01	36A164362AAG01	36A164402JEG01	NJ313-G1	
MD806	36A164403TBG01	SGE-5317	36A164403JCG01	SGE-5304	36A164403JGD01	NJ315-G1	
MD808	SGE-5309	SGE-5318	36A164404KBG01	SGE-5305	36A164404KFG01	NJ317-G1	
MD810	SGE-5310	SGE-5319	36A164405KBG01	SGE-5306	36A164405KDG01	NJ319-G1	
MD812	SGE-5311	36A164406AAG01	36A164406KBG01	36A164366AAG01	36A164406KEG01	NJ321-G1	
MD814	SGE-5312	36A164407AAG01	36A164407KBG01	SGE-5300	36A164407KDG01	NJ323	
MD816	SGE-5313	36A164408AAG01	36A164408KBG01	SGE-5307	36A164408KDG01	NJ326	
MD818	36A164409SBG01	36A164409AAG01	36A164409KBG01	36A164369AAG01	36A164409KDG01	NJ328	
MD800 CABLE BUSHINGS COMMON TO ALL 230V MOTORS							
FRAME	SERIES MOTOR	SHUNT MOTOR FIELD	COMPOUND MOTOR				
MD802A	36A164527AA001	SGE-5807	SGE-5807				
MD802B	SGE-5807	SGE-5807	SGE-5807				
MD803	SGE-5807	SGE-5807	SGE-5807				
MD804	36A164527CAG01	SGE-5807	SGE-5807				
MD806	SGE-5807	SGE-5808	SGE-5807				
MD808	SGE-5808	SGE-5808	SGE-5808				
MD810	SGE-5809	36A164527AE004	SGE-5809				
MD812	SGE-5810	36A164527AE002	SGE-5810				
MD814	SGE-5809	36A164527AA001	SGE-5809				
MD816	SGE-5810	SGE-5810	SGE-5810				
MD818	36A164527AB003	36A164527AA003	36A164527AD003				

The parts listed are standard parts for that series motor, if you have a custom or non standard motor supply us with the complete motor number and we will be glad to identify the parts for you.

GE KINAMATIC - II PARTS IDENTIFICATION

5CD122-123-124-125- Series - (140AT -- 1412AT Frame)

Example 5CD125TP002B

Brush Holder	Qty	Brush Spring	Qty	Brush	Qty	Fan
SGE-5045	2	SGE-5122	2	SGE-5212	2	SGE-5500

5CD14 Series - (CD180AT Frame)

Example 5CD14E01A900001

Brush Rigging	Qty	Brush Spring	Qty	Brush	Qty
SGE-5007	1	SGE-5101	2	SGE-5213	2

5CD142-143-144-145 Series - (CD180AT Frame)

Example 5CD143BA001A001

Brush Holder	Qty	Brush Spring	Qty	Brush	Qty
SGE-5008	1	SGE-5111	2	SGE-5209	2

5CD152-153-154 Series - (CD210AT Frame)

Example 5CD152JA001A001

If the next letter in model is;

A - S -- Qty. is 2 per motor

T - X -- Qty. is 4 per motor

Z -- Consult Factory

Brush Holder	Brush Spring	Brush (Std.)	Brush (Papermill Use)
SGE-5009	SGE-5109	SGE-5210	SGE-5218

5CD163-164- Series - (CD250AT Frame)

Example 5CD163SA001A001

If the next letter in model is;

A - N -- Qty. is 2 per motor

P - W -- Qty. is 4 per motor

Z -- Consult Factory

Brush Holder	Brush Spring	Brush (Std.)	Brush (Papermill Use)
SGE-5009	SGE-5109	SGE-5210	SGE-5218

5CD173-174- Series - (CD280AT Frame)

Example 5CD174RA001A001

If the next letter in model is;

A - T -- Qty. is 2 per motor

U - X -- Qty. is 4 per motor

Z -- Consult Factory

Brush Holder	Brush Spring	Brush (Std.)	Brush (Papermill Use)
SGE-5010	SGE-5110	SGE-5211	SGE-5219

5CD183-184- Series - (CD320AT Frame)

Example 5CD183KA001A001

If the next letter in model is;

A - R -- Qty. is 2 per motor

S - Y -- Qty. is 4 per motor

X -- Qty is 6 per motor

Z -- Consult Factory

Brush Holder	Brush Spring	Brush (Std.)	Brush (Papermill Use)
SGE-5010	SGE-5110	SGE-5211	SGE-5219

5CD192-193- 194 - Series - (CD360AT Frame)

Example 5CD194MA001A001

If the next letter in model is;

D - P -- Qty. is 4 per motor

B, C, R, S, T, X -- Qty. is 8 per motor

U, V, W -- Qty is 12 per motor

Z -- Consult Factory

Brush Holder	Brush Spring	Brush (Std.)	Brush (Papermill Use)
SGE-5005	SGE-5107	SGE-5214	SGE-5220

GE KINAMATIC - II PARTS IDENTIFICATION

5CD203-204- Series - (CD400AT Frame)

Example 5CD203PA001A001

If the next letter in model is;

D - M -- Qty. is 4 per motor

B, C, N, P, R -- Qty. is 8 per motor

A, S, T, X, Y -- Qty. is 12 per motor

U, V, W -- Qty. is 16 per motor

Z -- Consult Factory

Brush Holder	Brush Spring	Brush (Std.)	Brush (Papermill Use)
SGE-5000	SGE-5102	SGE-5215	SGE-5221

5CD222-223-224-226 - Series - (CD500AT Frame)

Example 5CD222LA001A001

If the next letter in model is;

F - L -- Qty. is 4 per motor

D, E, M, N, P -- Qty. is 8 per motor

C, R, S, Y -- Qty. is 12 per motor

A, B, T -- Qty. is 16 per motor

U, V, W -- Qty. is 20 per motor

Z -- Consult Factory

Brush Holder	Brush Spring	Brush (Std.)	Brush (Papermill Use)
SGE-5001	SGE-5103	SGE-5216	SGE-5223

5CD362-363 Series - (2512AT - 2513AT Frame)

Example 5CD362MA001A001

A - P -- Qty. is 2 per motor

R - X -- Qty. is 4 per motor

Z -- Consult Factory

Brush Holder	Brush Spring	Brush (Std.)	Brush (Papermill Use)
SGE-5050	SGE-5123	SGE-5217	SGE-5222

5CD372-373 Series - (2812AT - 2813AT Frame)

Example 5CD372MA001A001

A - P -- Qty. is 2 per motor

R - X -- Qty. is 4 per motor

Z -- Consult Factory

Brush Holder	Brush Spring	Brush (Std.)	Brush (Papermill Use)
SGE-5050	SGE-5123	SGE-5217	SGE-5222

The parts listed are standard parts for that series motor, if you have a custom or non standard motor supply us with the complete motor number and we will be glad to identify the parts for you.

GENERAL ELECTRIC - II PARTS IDENTIFICATION

KINAMATIC II CD180AT FRAME EXPLODED VIEW

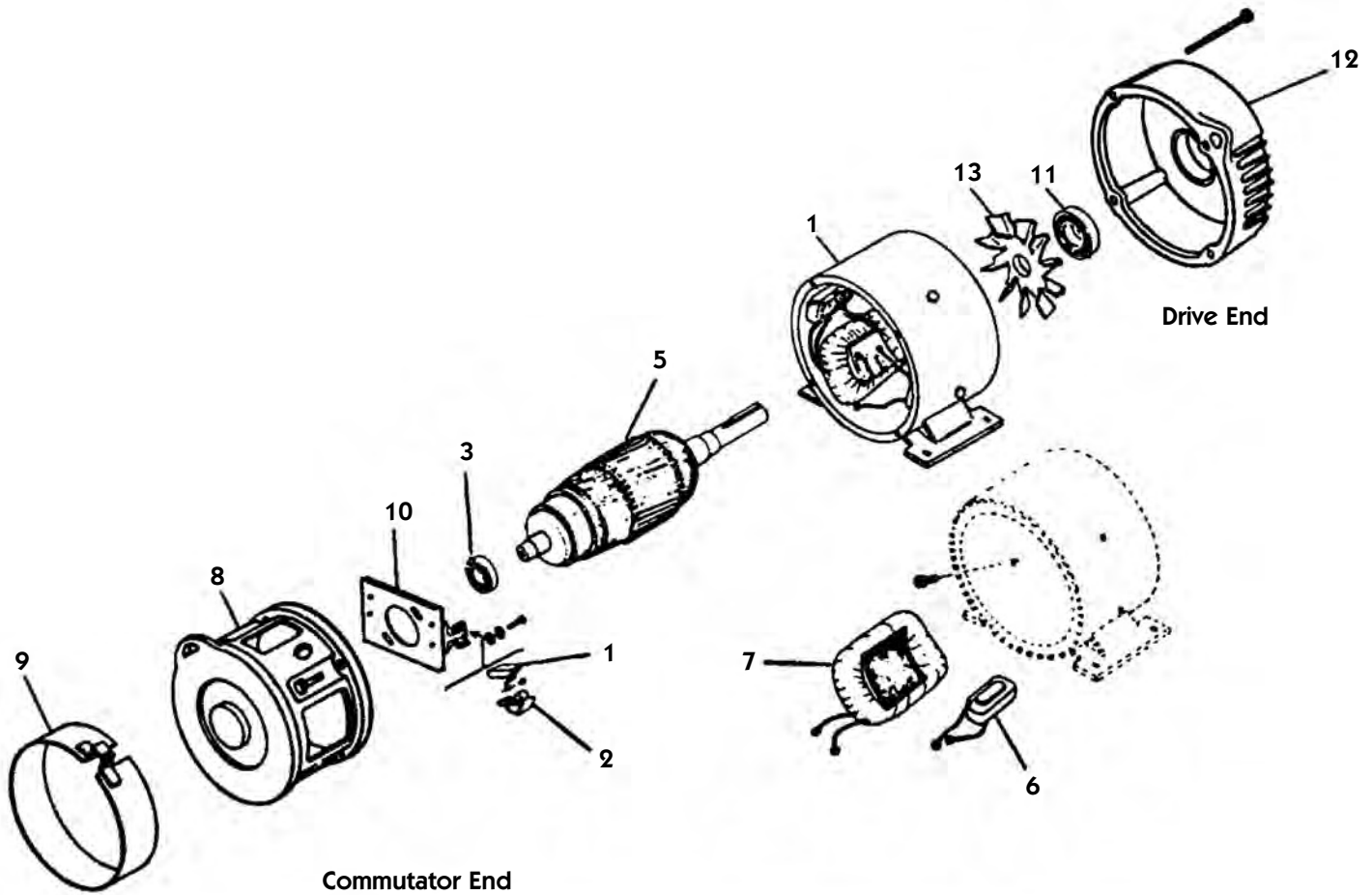

REF. #	DESCRIPTION	QUANTITY
1	Brush	2
2	Brush Springs	2
3	Bearing C.E.	1
4	Bearing D.E.	1
5	Armature	1
6	Coil & Pole, Comm.	2
7	Coil, Main	2
8	Bearing Bracket (CE)	1
9	Access Cover	1
10	Brush Rigging	1
11	Armature Fan	1
12	Bearing Bracket (DE)	1
13	Wound Frame Assembly	1

KINAMATIC II CD210AT - CD500AT FRAME EXPLODED VIEW

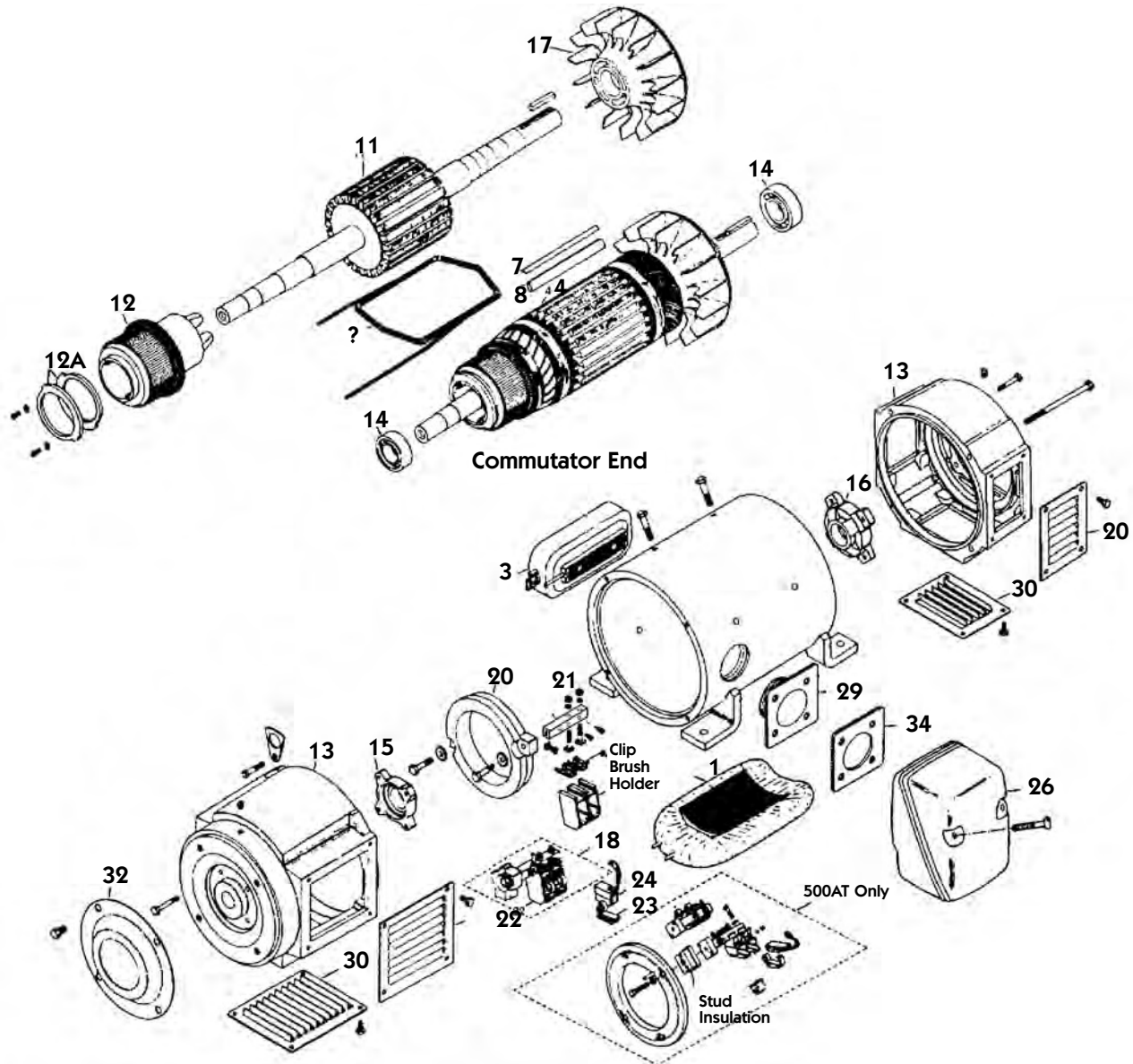

REF. #	DESCRIPTION
1	Main Coil & Pole Assembly
3	Comm. Coil & Pole Assembly
4	Armature
5	Armature Coil
7	Slot Wedge (Through CD400AT)
8	Slot Insulation (Through CD400AT)
11	Armatur Shaft & Core Assembly
12	Commutator
13	Bearing Bracket (Specify CE or DE)
14	Ball Bearing (Specify CE or DE)
15	Bearing Cap (Specify CE or DE)
17	Armature Fan
18	Brush Rigging (includes Complete Assembly for CD180AT)

REF. #	DESCRIPTION
20	Brush Holder Yoke
21	Brush Holder (Includes Insulator on CD500AT)
22	Brush Holder (With Spring and Clip)
23	Brush Holder Spring
24	Carbon Brush
26	Conduit Box
29	Conduit Box Adaptor
30	Bearing Bracket Covers (Specify DE or DE, Side Top or Bottom)
32	Shaft Cover
34	Conduit Box Gasket
38	Bearing Retaining Ring (Used on CD360AT-CD500AT DE only.)

GENERAL ELECTRIC

KINAMATIC II CD2512AT - CD2813AT FRAME EXPLODED VIEW

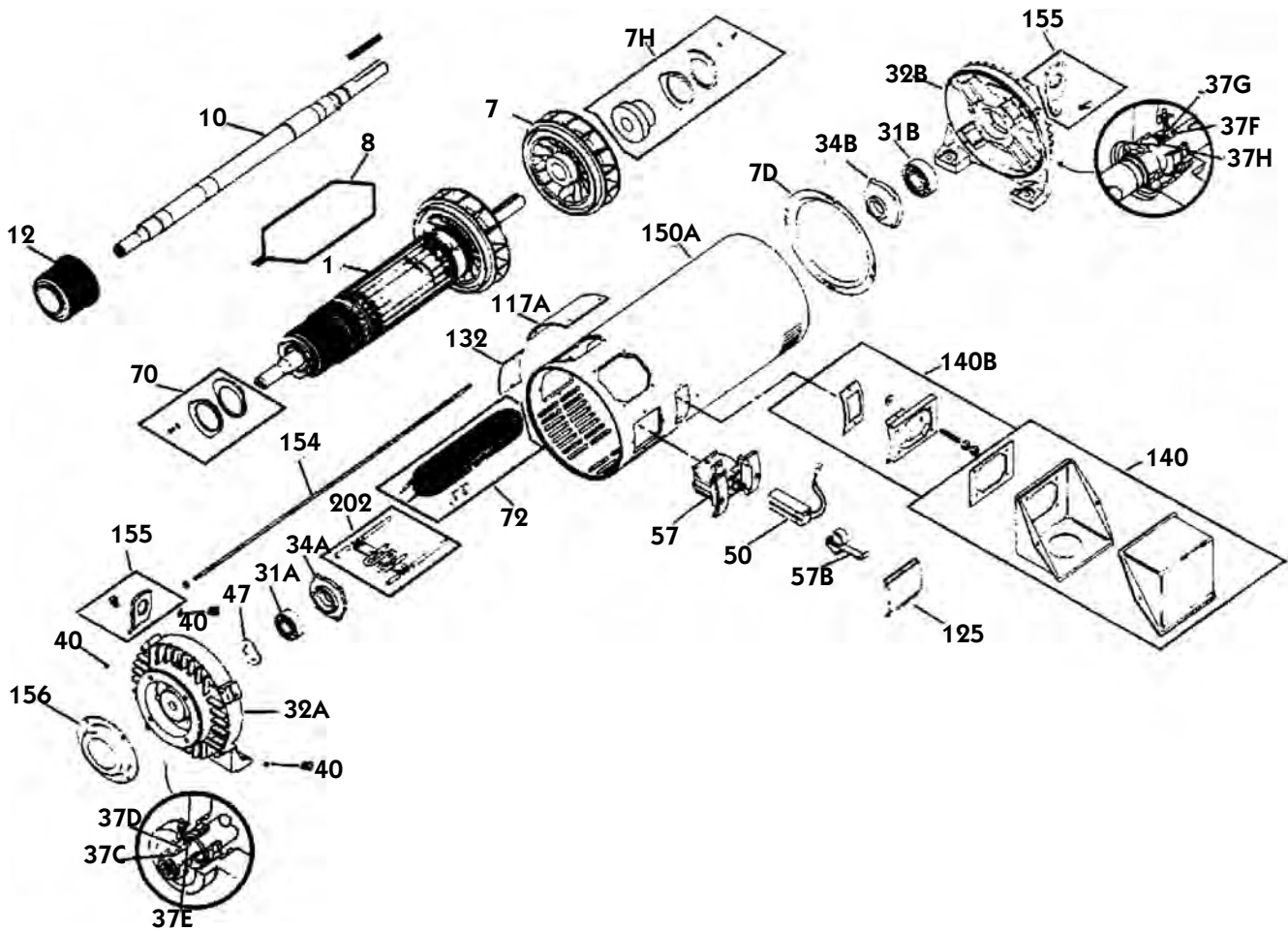

REF. #	DESCRIPTION
1	Armature
7	Armature Fan
7D	Armature Baffle
7G	Balance Ring Kit, CE
7H	Balance Ring Kit DE
8	Armature Rewind Kit
10	Shaft w/Key
12	Commutator (Requires No. 8 Rewind Kit)
31A	Bearing, CE
31B	Bearing, DE
32A	Bearing Bracket, CE
32B	Bearing Bracket, DE
34A	Bearing Cap, CE
34B	Bearing Cap, DE
37C	Bearing Seal, Labyrinth CE (when specified)
37D	Bearing Seal, Adapter CE (when specified)
37E	Bearing Seal, Rubbing CE (when specified)
37F	Bearing Seal, Labyrinth DE (when specified)

REF. #	DESCRIPTION
37G	Bearing Seal Adapter DE (when specified)
37H	Bearing Seal Rubbing DE (when specified)
40	Grease Fitting Kit
47	Bearing Preload Spring
50	Brush
57	Brush Holder
57B	Brush Holder Spring
72	Comm. Coil Kit
117A	Cover, Top CE. Solid
125	Cover, Brush Holder w/Gasket
132	Cover, Opposite Conduit Box
140	Conduit Box
140B	Conduit Box Adapter Kit
150A	Coiled Frame
153	Shaft Thimble
154	Bracket to Frame Stud
155	Lifting Lug Kit
202	Space Heater Kit

CD & MCD 4300 - 4700 SERIES V-HOLDER BRUSH RIGGING

V-Style Brush Holder

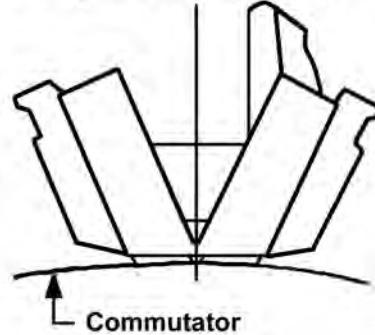

BRUSH THICKNESS	BRUSH HOLDER	SPRING	BRUSH STD.	BRUSH PAPERMILL	BRUSH (EXTRUDER)
3/8" X 1-1/2" Brush	36A172040AAG03	36B472000AA003	36A164454DAP01	36A164454DAP05	36A164454DAP02
1/2" X 1-1/2" Brush	36A172040AAG02	36B472000AA002	36A164455DAP01	36A164455DAP05	36A164455DAP02
5/8" X 1-1/2" Brush	36A172040AAG01	36B472000AA001	36A164456DAP01	36A164456DAP05	36A164456DAP02

TYPE CD & MCD FRAME 5000 - 9000 TYPE CD FRAME 580 - 680

When identifying parts for CD580 -CD680 series motors, (Ex. 5C584E22). Your customer must identify the type of brushholder stud used in the motor and the thickness of the brush. The same holds true for CD5000 - CD9000 series motors (Ex. 5CD27E30C507122). The underlined digits must be either 25, 26, 27, 28 or 29.

CD580-680 & CD5000 - CD9000 Frames Two Piece Brush Holder Stud

Use this chart for insulated block & stud (2 piece design)

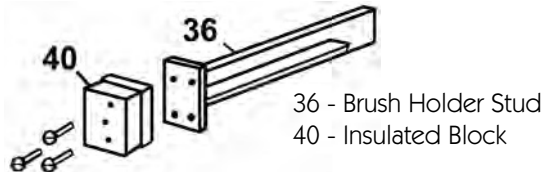

BRUSH THICKNESS	BRUSH HOLDER	SPRING	BRUSH STD.	BRUSH PAPERMILL
3/4" Brush	SGE-5000	SGE-5102	SGE-5239	SGE-5233
7/8" Brush	SGE-5001	SGE-5103	SGE-5216	SGE-5223
1" Brush	SGE-5002	SGE-5104	SGE-5240	SGE-5234

CD580-680 & CD5000 - CD9000 Frames One Piece Brush Holder Stud

Use this chart for Fluid Bed Stud (1 Piece Design)

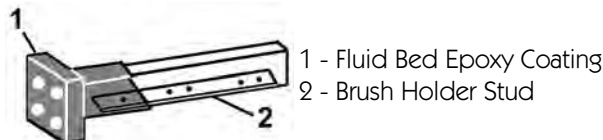

BRUSH THICKNESS	BRUSH HOLDER	SPRING	BRUSH STD.	BRUSH PAPERMILL
3/4" Brush	SGE-5040	SGE-5113	SGE-5231	SGE-5230
7/8" Brush	SGE-5012	SGE-5114	SGE-5232	SGE-5236
1" Brush	SGE-5013	SGE-5115	SGE-5235	SGE-5237

The parts listed are standard parts for that series motor. If you have a custom or non standard motor, supply us with the complete motor number and we will be glad to identify the parts for you.

HOBART MOTOR PARTS

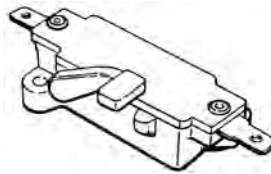

SHO-A

PHOTO REF.	CONTACTS		MOUNTING HOLES		PLATE SIZE		SPADES		I.D. (IN.)	FRAME SIZE/NOTES	PART NUMBER
	N.O.	N.C.	C-TO-C (IN.)	WIDTH (IN.)	LENGTH (IN.)	FRONT	BACK	STUDS			
SHO-A	1	-	1-7/8	3/4	2-3/16	2	-	-	-	-	SHO-15

HOWELL MOTOR PARTS

Includes listings for Jack & Heintz, Kingston Conley, & Ohio Electric Motors

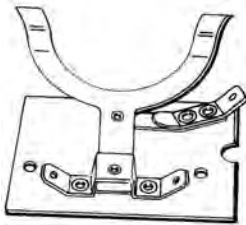

HEM-A

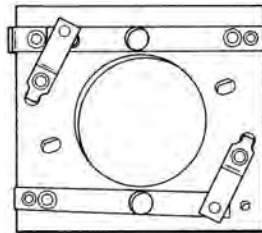

HEM-B

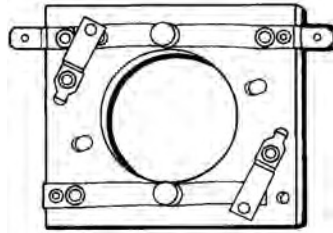

HEM-C

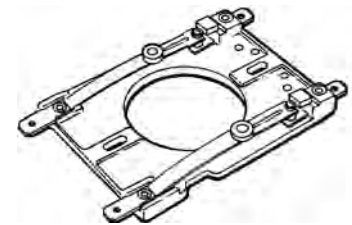

STQ-A

PHOTO REF.	CONTACTS		MOUNTING HOLES		PLATE SIZE		SPADES		I.D. (IN.)	FRAME SIZE/NOTES	PART NUMBER
	N.O.	N.C.	C-TO-C (IN.)	WIDTH (IN.)	LENGTH (IN.)	FRONT	BACK	STUDS			
HEM-A	1	-	1-7/8	1-1/2	2-7/16	3	-	-	-	-	SKC-46
HEM-B	1	-	1-7/8	2-3/8	2-1/2	-	-	-	1-3/8	Metal contact pads on arms	SOH-55
HEM-B	1	1	1-7/8	2-3/8	2-1/2	-	-	-	1-3/8	Metal contact pads on arms	SOH-58
HEM-C	1	-	1-7/8	2-3/8	2-9/16	2	-	-	1-13/32	-	SOH-59
STQ-A	2	-	2-1/2 X 2-3/4	2-1/2	3-7/16	4	-	-	1-11/16	1/4" Dia. contacts, With removeable jumper wire	STQ-200

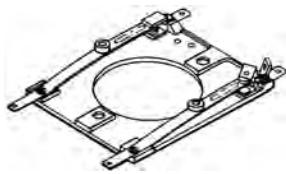

HEM-D

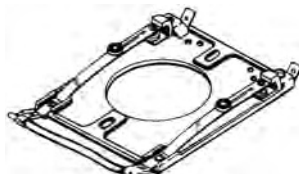

STQ-B

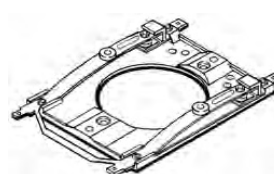

STQ-C

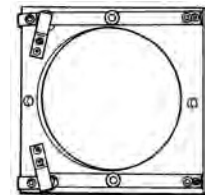

HEM-F

PHOTO REF.	CONTACTS		MOUNTING HOLES		PLATE SIZE		SPADES		I.D. (IN.)	FRAME SIZE/NOTES	PART NUMBER
	N.O.	N.C.	C-TO-C (IN.)	WIDTH (IN.)	LENGTH (IN.)	FRONT	BACK	STUDS			
HEM-D	2	1	2-11/16	3-1/16	3-7/16	5	-	-	1-15/16	-	SJH-29
STQ-B	2	-	2-11/16 X 2-3/4	3-1/16	3-7/16	4	-	-	1-15/16	5/16" Dia. contacts, With removeable jumper wire	STQ-250
STQ-C	2	-	2-3/4 X 3-3/8	3-1/4	3-7/8	4	-	-	2-1/4	3/8" Dia. contacts, With Metal Jumper	STQ-300
HEM-F	2	-	3-3/8	3-1/4	3-7/8	-	-	-	2-29/32	-	SKC-39

IRON FIREMAN INSTANT REVERSING SWITCHES

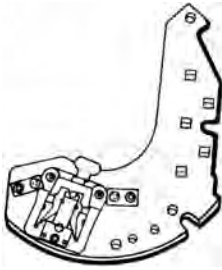

SIF-A

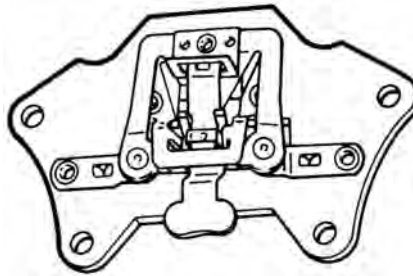

SIF-B

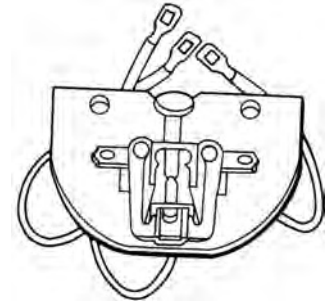

SIF-C

PHOTO REF.	CONTACTS		C TO C (IN.)	MTG. WIDTH (IN.)	LENGTH (IN.)	FRONT	SPADE TERMINALS		NOTES	PART NUMBER
	N.O.	N.C.					BACK			
SIF-A	1	1	1-1/4 X 3-9/16	-	-	-	-	-	R97-19	SGE-752
SIF-B	1	1	1-13/16 X 2-3/4	2-1/8	3-1/8	3	-	-	W/quick connect terminals # R98-6	SIF-12
SIF-B	1	1	1-13/16 X 2-3/4	2-1/8	3-1/8	-	-	-	W/O terminals # R99-1	SIF-4
SIF-C	1	1	2	2-3/16	3-3/8	-	-	-	3 - 12" Leads (Blk, Red & Purple), # R97-6	SIF-6

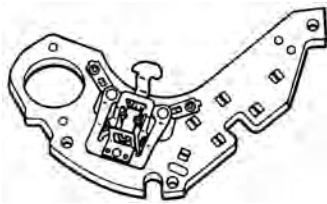

SIF-D

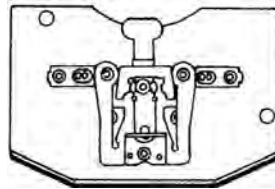

SIF-E

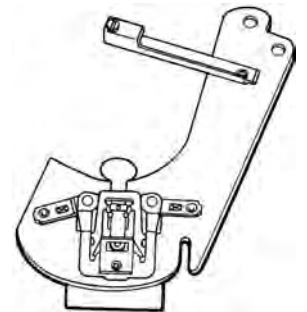

SIF-F

PHOTO REF.	CONTACTS		C TO C (IN.)	MTG. WIDTH (IN.)	LENGTH (IN.)	FRONT	SPADE TERMINALS		NOTES	PART NUMBER
	N.O.	N.C.					BACK			
SIF-D	1	1	2-1/16 X 4	-	-	-	-	-	#R98-1	SGE-695
SIF-E	1	1	3	2-1/4	3-3/8	-	-	-	#R99-4	SGE-677
SIF-F	1	1	3-1/16 X 5/8	-	-	-	-	-	#R98-3	SMA-201

LEESON MOTOR PARTS

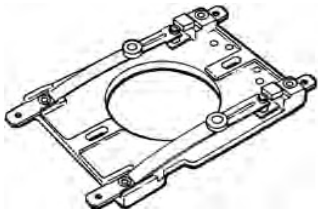

STQ-A

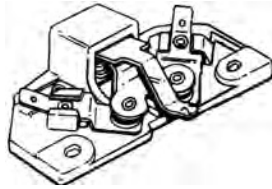

SLS-B

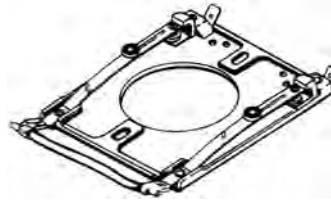

STQ-B

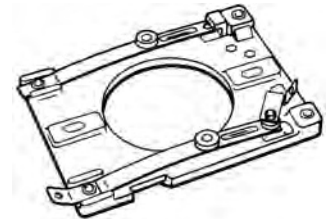

SLS-B

PHOTO REF.	CONTACTS		MOUNTING HOLES		PLATE SIZE		SPADES		I.D. (IN.)	FRAME SIZE/ NOTES	PART NUMBER
	N.O.	N.C.	C-TO-C (IN.)	WIDTH (IN.)	LENGTH (IN.)	FRONT	BACK	STUDS			
STQ-A	2	-	2-1/2 X 2-3/4	2-1/2	3-7/16	4	-	-	1-11/16	1/4" Dia. contacts, With removeable jumper wire	STQ-200
SLS-A	2	-	2-1/2	3-1/4	1-5/8	2	-	-	-	-	SBA-122
STQ-B	2	-	2-11/16 X 2-3/4	3-1/16	3-7/16	4	-	-	1-15/16	5/16" Dia. contacts, With removeable jumper wire	STQ-250
SLS-B	-	1	2-3/4	2-1/2	3-29/64	2	-	-	1-11/16	-	SLS-13

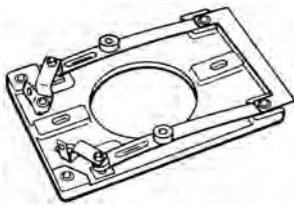

SLS-C

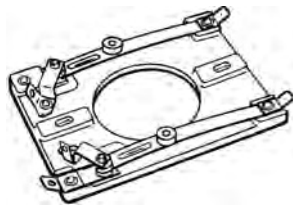

SLS-D

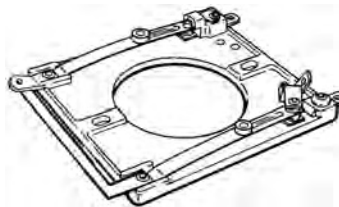

SLS-E

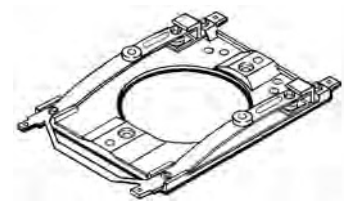

STQ-C

PHOTO REF.	CONTACTS		MOUNTING HOLES		PLATE SIZE		SPADES		I.D. (IN.)	FRAME SIZE/ NOTES	PART NUMBER
	N.O.	N.C.	C-TO-C (IN.)	WIDTH (IN.)	LENGTH (IN.)	FRONT	BACK	STUDS			
SLS-C	-	2	2-3/4	2-1/2	3-29/64	2	-	-	1-11/16	Metal jumper bar	SLS-15
SLS-D	1	2	2-3/4	2-1/2	3-29/64	5	-	-	1-11/16	-	SLS-26
SLS-E	2	1	2-3/4	2-1/2	3-29/64	4	-	-	1-11/16	-	SLS-27
STQ-C	2	-	2-3/4 X 3-3/8	3-1/4	3-7/8	4	-	-	2-1/4	3/8" Dia. contacts, With Metal Jumper	STQ-300

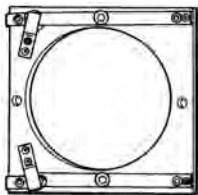

SLS-F

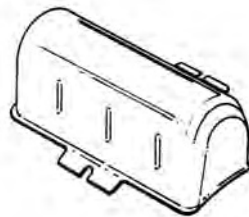

SLS-G



SLS-H

PHOTO REF.	CONTACTS		MOUNTING HOLES		PLATE SIZE		SPADES		I.D. (IN.)	FRAME SIZE/ NOTES	PART NUMBER
	N.O.	N.C.	C-TO-C (IN.)	WIDTH (IN.)	LENGTH (IN.)	FRONT	BACK	STUDS			
SLS-F	2	-	3-3/8	3-27/32	3-7/8	5	-	-	2-29/32	Removeable wire jumper	SLS-29

PHOTO REF.	DESCRIPTION	PART NUMBER
SLS-G	Capacitor Cover for 2-1/16" X 4-3/8" Capacitors	SLS-30
SLS-G	Capacitor Cover for 1-13/16" X 4-3/8" Capacitors	SLS-31
SLS-H	Run Capacitor 16 MFD X 240 Volt 1-3/4" Dia. X 3-1/2" Long	SLS-6

LELAND GAS PUMP SWITCHES

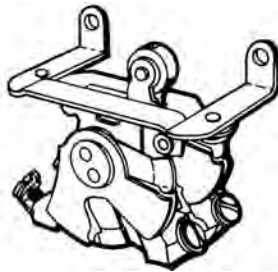

SLE-A

PHOTO REF.	CONTACTS	MOUNTING HOLES C TO C (IN.)	CURRENT RATING	NOTES	PART NUMBER
SLE-A	DPST	2-3/8	30 Amp @ 250 VAC	1HP 480VAC/2HP120/240 VAC, Bracket Right Hand	SLE-98R
SLE-A	DPST	2-3/8	30 Amp @ 250 VAC	1HP 480VAC/2HP120/240 VAC, Bracket Left Hand	SLE-98L

LIMA MOTOR PARTS

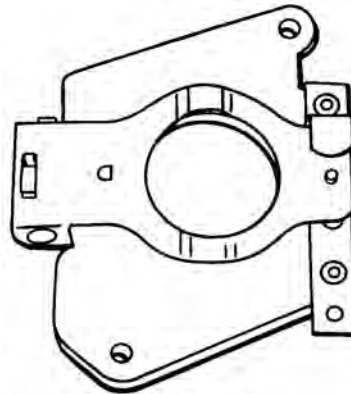

SLI-A

PHOTO REF.	CONTACTS		MOUNTING HOLES C TO C (IN.)	WIDTH (IN.)	LENGTH (IN.)	SPADE TERMINALS		I.D. (IN.)	NOTES	PART NUMBER
	N.O.	N.C.				FRONT	BACK			
SLI-A	1	-	3	2-1/4	2-1/2	-	-	1-1/16	2 Solder terminals	SLI-1

MAGNETEK MOTOR PARTS

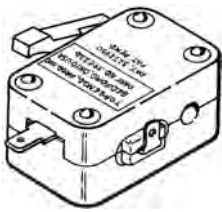

SCN-A

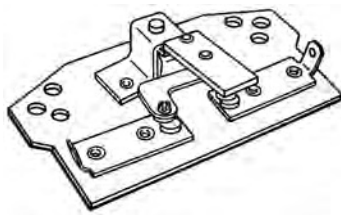

SCN-B

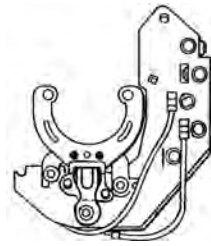

SCN-C

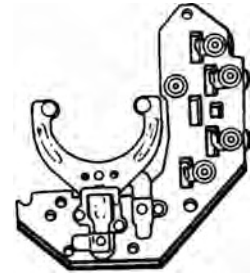

SCN-D

PHOTO REF.	CONTACTS		MOUNTING HOLES C-TO-C (IN.)	PLATE SIZE		SPADES			I.D. (IN.)	FRAME SIZE/ NOTES	PART NUMBER
	N.O.	N.C.		WIDTH (IN.)	LENGTH (IN.)	FRONT	BACK	STUDS			
SCN-A	1	-	1-5/8 (1-7/8" Diag.)	1-5/16	2-3/32	2	-	-	-	1" High	SCN-452
SCN-B	2	-	2-3/4	2-3/16	4	2	-	-	-	-	SCN-439
SCN-B	2	-	2-3/4	2-3/16	4	2	-	-	-	Has dust cover over contacts	SCN-507
SCN-B	2	-	2-3/4	2-3/16	4	2	-	-	-	Torq Replacement for SCN-439	STQ-439
SCN-C	2	-	2-3/4 X 3-5/16	-	-	5	7(1)	2(2)	-	(1) Singles at contact, SCN-514 Contact, 2, 3 & 4, Double at 5, (2) at 2 & 4 on back, Jumpers from contact to 5 & contact to 3	SCN-532
SCN-D	1	-	2-3/4 X 3-5/16	-	-	2	1	1	-	-	SCN-486
SCN-D	1	-	2-3/4 X 3-5/16	-	-	8	10(1)	3(2)	-	(1) Singles at 1, 6 & Blank Doubles at 2 & 5 Triple at 4 (2) at 1, 2 & 4	

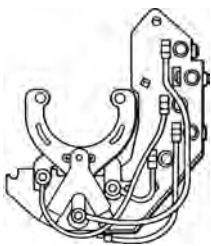

SCN-E

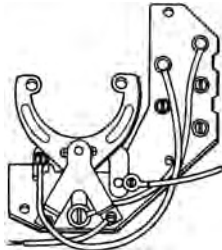

SCN-F

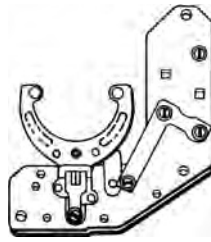

SCN-G

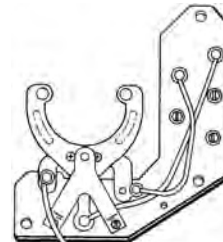

SCN-H

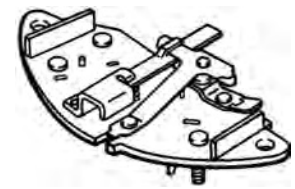

SCN-I

PHOTO REF.	CONTACTS		MOUNTING HOLES C-TO-C (IN.)	PLATE SIZE		SPADES			I.D. (IN.)	FRAME SIZE/ NOTES	PART NUMBER
	N.O.	N.C.		WIDTH (IN.)	LENGTH (IN.)	FRONT	BACK	STUDS			
SCN-E	2	1	2-3/4 X 3-5/16	-	-	8(1)	5	3(2)	-	(1)Single at 1, 2, 3 & B Double at 4 & 5 (2)at 2, 3 & 4, 3 Jumpers	SCN-466
SCN-E	2	1	2-3/4 X 3-5/16	-	-	6(1)	5	3(2)	-	(1)Single at 1, 2, 3 & B, Double at 5 (2) at 2, 4 & 5, 3 Jumpers	SCN-467
SCN-F	2	1	2-5/8 X 2-5/8	-	-	-	3(1)	5(2)	-	(1)at 1, 4 & 5, (2) screw terminals at 1, 2, 3, 4, & 5 on back, Two jumpers & one lead	SCN-474
SCN-G	1	-	3 X 3-1/4	-	-	-	2(1)	4(2)	-	(1) at 1 & 4, (2) Screw terminals at 1, 2, 3 & 4 on back, Jumper bar between contact, 1 & 2	SCN-425
SCN-H	2	1	3 X 3-1/4	-	-	-	3(1)	5(2)	-	(1) at 1, 4 & 5, (2) at 1, 2, 3, 4 & 5 on back, Jumper bar between 1 & 2, 2 Jumpers one lead	SCN-451
SCN-I	1	-	3-5/16	-	-	1	11(1)	2(2)	-	(1) Singles at 1 & 4 Doubles at 2, 3, & 5 Triple at 6 (2)at 1 & 6	SCN-471
SCN-I	1	-	3-5/16	-	-	1	-	-	-	-	SCN-476
SCN-I	1	-	3-5/16	-	-	1	8(1)	2(2)	-	(1)Single at 3 & 4, Double at 1 & 5 Triple at 6 (2) at 1 & 5	SCN-533

MAGNETEK MOTOR PARTS



SCN-J

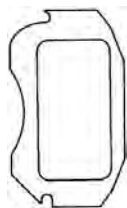

SCN-K

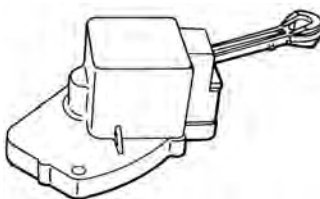

SCN-L

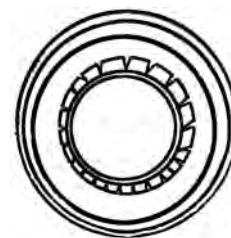

SCN-M

PHOTO REF.	MOUNTING HOLES C TO C (IN.)	WIDTH (IN.)	LENGTH (IN.)	SPADES		STUDS	NOTES	PART NUMBER
				FRONT	BACK			
SCN-J	3-5/16	1-1/2	3-13/16	7(1)	3	2(2)	(1)Single at 4 double at L1, 3 & L2 (2) screw terminals at L1 & L2 Used on PSC pump motors	SCN-513
SCN-K	2-3/4	1-11/16	3	Terminal Cover Plate				SCN-515
SCN-L	2-3/4			Sump pump switch DPST 10A/125VAC, 5A250VAC 1/2 HP 125 VAC				SCN-480
SCN-M				Wicking retainer cap 15/16" ID X 1-15/16" OD X 3/8" Thick				SCN-524

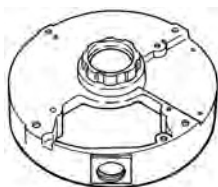

SCN-N

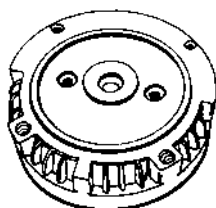

SCN-O

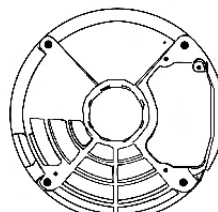

SCN-P

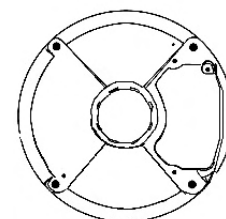

SCN-Q

PHOTO REF.	BEARING	NOTES	PART NUMBER
SCN-N	203	6-1/4" Dia., Totally enclosed Opp. Drive end used on pump motors	SCN-509
SCN-O	304	6-1/4" Dia., Open C-flange endbell for pump motors	SCN-510
SCN-P	Sleeve	6-1/4" Dia., Open, Drive end endbell	SCN-534
SCN-P	203	6-1/4" Dia., Open, Drive end endbell	SCN-535
SCN-P	Sleeve	6-1/4" Dia., Open, Opp. Drive end endbell	SCN-536
SCN-P	203	6-1/4" Dia., Open, Opp. Drive end endbell	SCN-537
SCN-Q	Sleeve	6-1/4" Dia., Totally enclosed, DE & ODE Used on Nesbitt Motors	SCN-538

MARATHON MOTOR PARTS

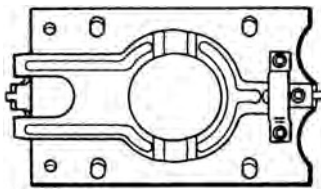

SMR-A

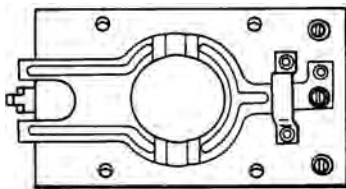

SMR-B

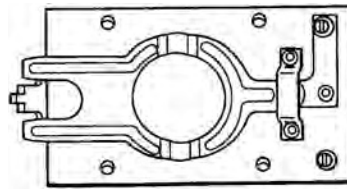

SMR-C

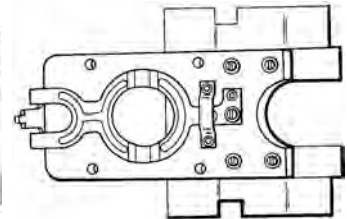

SMR-D

PHOTO REF.	CONTACTS		MOUNTING HOLES C-TO-C (IN.)	PLATE SIZE		SPADES			I.D. (IN.)	FRAME SIZE/ NOTES	PART NUMBER
	N.O.	N.C.		WIDTH (IN.)	LENGTH (IN.)	FRONT	BACK	STUDS			
SMR-A	1	-	1-13/16 X 1-13/16	2-3/16	3-3/8	-	-	-	1	2 Solder terminals at contact turned up.	SMR-43
SMR-A	1	-	1-13/16 X 1-13/16	2-3/16	3-3/8	-	-	-	1	2 Solder terminals at contact turn down.	SMR-58
SMR-B	1	-	1-13/16 X 1-13/16	2-3/16	3-11/16	-	-	2(1)	1	(1) at L1& L2	SMR-48
SMR-B	1	-	1-13/16 X 1-13/16	2-3/16	3-1/2	-	-	3(1)	29/32	(1) at 1, 2 & 3	SMR-56
SMR-C	1	-	1-13/16 X 1-13/16	2-3/16	3-1/2	-	-	2(1)	29/32	Insulation attached to board. (1) at 1& 2 Jumper from contact to 1, Insulation attached to board.	SMR-57
SMR-C	1	-	1-13/16 X 1-13/16	2-3/16	3-11/16	-	-	2(1)	1	(1) at 1 & 2, Jumper from Contact to 1	SMR-59
SMR-D	1	-	1-13/16 X 1-13/16	2-3/16	4-1/16	-	-	4(1)	1	(1) at 1, 2, 3 & 4 Insulation attached to board.	SMR-60

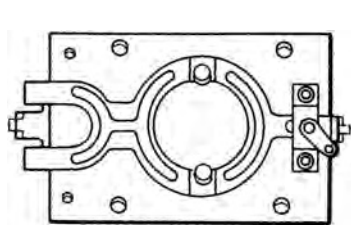

SMR-E

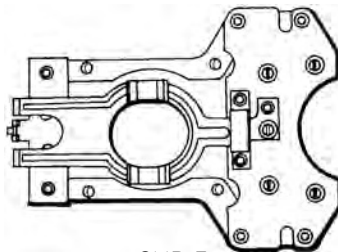

SMR-F

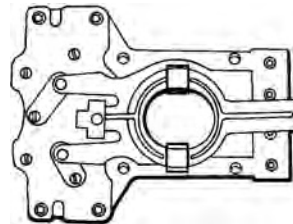

SMR-G

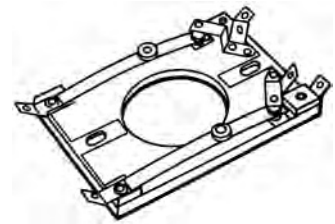

SMR-H

PHOTO REF.	CONTACTS		MOUNTING HOLES C-TO-C (IN.)	PLATE SIZE		SPADES			I.D. (IN.)	FRAME SIZE/ NOTES	PART NUMBER
	N.O.	N.C.		WIDTH (IN.)	LENGTH (IN.)	FRONT	BACK	STUDS			
SMR-E	1	1	1-13/16 X 1-13/16	2-3/16	3-11/16	-	-	-	1	2 Solder Terminals	SMR-73
SMR-E	1	-	1-13/16 X 1-13/16	2-3/16	3-1/8	-	-	-	29/32	-	SMR-69
SMR-F	1	-	1-13/16 X 1-13/16	3-1/2	4-5/8	-	-	4(1)	1	(1) at 1, 2, 3 & 4	SMR-61
SMR-G	2	1	1-13/16 X 1-13/16	-	-	-	-	3(1)	1	(1) at 1, 2, & 5	SMR-62
SMR-H	2	2	2-1/16	2-3/8	3-7/16	6	-	-	1-11/16	Used on Huebsch Motors	SMR-94

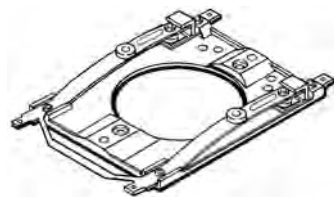

SMR-I

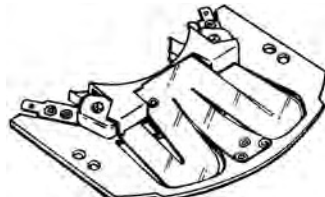

SMR-J

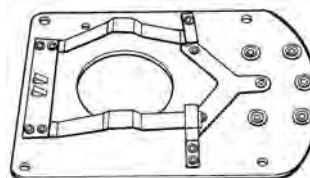

SMR-K

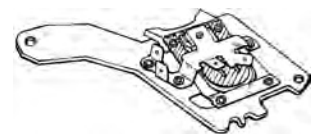

SMR-L

PHOTO REF.	CONTACTS		MOUNTING HOLES C-TO-C (IN.)	PLATE SIZE		SPADES			I.D. (IN.)	FRAME SIZE/ NOTES	PART NUMBER
	N.O.	N.C.		WIDTH (IN.)	LENGTH (IN.)	FRONT	BACK	STUDS			
SMR-I	2	-	2-3/4 & 3-3/8	3-1/4	3-7/8	4	-	-	2-1/4	3/8" Dia. contacts with metal jumper	STQ-300
SMR-J	2	-	4-1/4	3-5/16	4-13/16	2	-	-	-	-	SMR-104
SMR-K	2	-	4-1/4 X 4-7/8	4-3/4	6-1/2	-	-	6(1)	2-1/4	(1) at 1, 2, 3, 4, 5 & 6 Jumper between 2 & 4, 1 & 6, 5 & 6	SMR-54
SMR-K	2	-	4-1/4 X 4-7/8	4-3/4	6-1/2	-	-	6(1)	2-1/4	(1) at 1, 2, 3, 4, 5 & 6 Jumper between 4 & 5, 1 & 6	SMR-127
SMR-K	2	-	4-1/4 X 4-7/8	4-3/4	6-1/2	-	-	1(1)	2-1/4	(1) at 3	SMR-128
SMR-L	1	-	4-3/8	2-1/8	4-3/4	5	-	-	-	-	SMR-105

MARATHON MOTOR PARTS

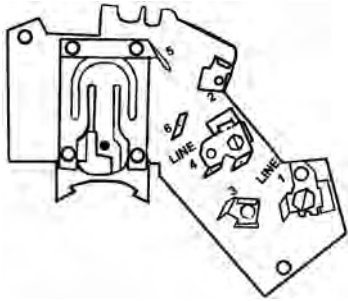

SMR-M

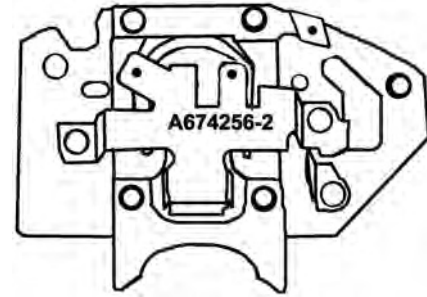

SMR-N

PHOTO REF.	CONTACTS		MOUNTING HOLES		PLATE SIZE		SPADES		I.D. (IN.)	FRAME SIZE/ NOTES	PART NUMBER
	N.O.	N.C.	C-TO-C (IN.)	WIDTH (IN.)	LENGTH (IN.)	FRONT	BACK	STUDS			
SMR-M	1	-	4-3/8	3-7/8	4-3/8	10(1)	5	2(2)	-	(1) singles at L1, 6 and contact, Doubles at 2 & 3, Triple at L4. (2) Screw terminals	SMR-107
SMR-N	1	-	2-3/8	1-5/8	2-13/16	4	2	-	-	-	SMR-129

RELIANCE MOTOR PARTS

STATIONARY SWITCHES

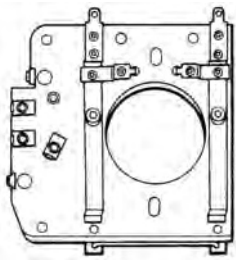

SMA-A

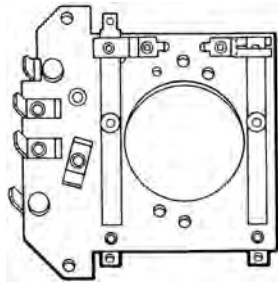

SMA-B

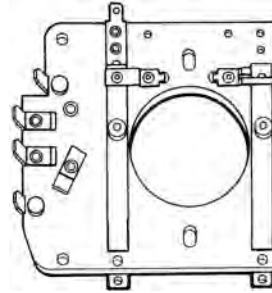

SMA-C

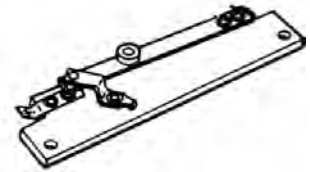

SMA-D

PHOTO REF.	CONTACTS		MOUNTING HOLES C-TO-C (IN.)	PLATE SIZE		SPADES		I.D. (IN.)	NOTES	PART NUMBER	
	N.O.	N.C.		WIDTH (IN.)	LENGTH (IN.)	FRONT	BACK				STUDS
A	2	-	2-11/16 x 3-1/4	3-7/8	3-3/4	7	4(1)	2	1-7/8 (1) at L1,3,L2 & Blank Wire Shunt Between Solder Terminals	SMA-170	
B	1	-	2-3/16 x 3-1/4	3-9/32	3-39/64	6	3(1)	2	1-5/8 (1) at L1,3,&L2	SMA-172	
B	1	-	2-3/16 x 3-1/4	3-9/32	3-39/64	6	4(1)	2	1-5/8 (1) at 2,3,L2,&4	SMA-175	
B	2	-	2-3/16 x 3-1/4	3-9/32	3-39/64	4	4(1)	2	1-5/8 (1) at L1,3,L2,&4 Wire Jumper	SMA-217	
B	1	-	2-3/16 x 3-1/4	3-9/32	3-39/64	5	4(1)	3	1-5/8 (1) at L1,2,L2,&4 Jumper Between Solder Terminals	SMA-218	
C	1	-	2-11/16 x 3-1/4	3-7/8	3-3/4	6	4(1)	2	1-7/8 (1) at L1,3,Blank,&L2	SMA-171	
D	1	-	3-11/16	1-3/32	4-1/8	2	-	-	-	SMA-220	
E	1	-	1-7/8 x 3-1/4	-	-	6	8	2(1)	(1) in Back	SMA-219	
F	2	-	3-55/64 x 3-17/32	4-3/8	4-1/2	2 at T5 & T9	2(1)	-	4 Metal Jumpers (1) at C & D No. on Switch is 36C072	SMA-246	
G	-	-	1-7/8	3/4	2-3/16	2	-	-	-	SHO-15	
H	1	-	1-5/8 (1-7/8 Diag.)	1-5/16	2-3/32	2	-	-	-	Dustite Switch 1" High	SCN-452
I	1	-	1-7/8	2-3/8	2-1/2	-	-	-	1-3/8	Metal Pads on Contact Arms	SOH-55

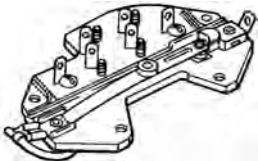

SMA-E

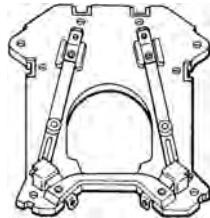

SMA-F

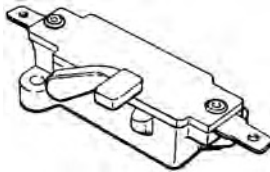

SMA-H

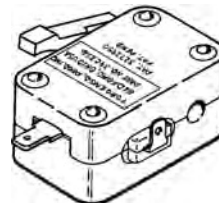

SMA-H

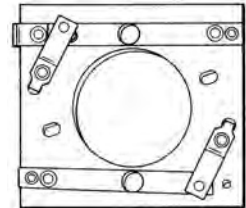

SMA-I

INSTANT REVERSING SWITCH

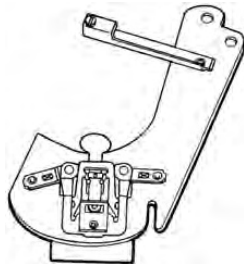

SMA-J

PHOTO REF.	WIDTH	LENGTH	MOUNTING HOLES C. TO C. (IN.)	REMARKS	PART NUMBER
J	-	-	3-1/16 x 5/8	Instant Reversing Contacts N/O: 2 No. on Unit R98-3	SMA-201

RELIANCE MOTOR PARTS

ASSORTED MOTOR ACCESSORIES

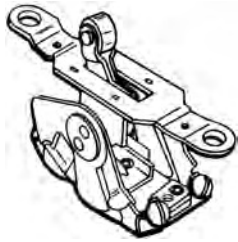

SMA-K

PHOTO REF.	DESCRIPTION	REMARKS	PART NUMBER
K	Gas Pump Switch	Mounting Hloes C to C 2-3/8" 30 Amp 250V 1H.P 480 VAC 2 H.P. 120/240 VAC	SMA-113
L	Brush Spring	Length 1-3/8" Width 1/4"	SMA-20
L	Brush Spring	Length 1-5/8" Width 1/4"	SMA-21
L	Brush Spring	Length 2-3/4" Width 3/8"	SMA-22



SMA-L

SHORT CIRCUITING DEVICES & SPRINGS

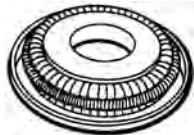

SMA-M

INSIDE DIA. (IN.)	OUTSIDE DIA. (IN.)	SPEED (RPM)	DEVICE PART NUMBER	SPRING PART NUMBER
11/16	2-7/32	1750	SMA-7-17	SMA-15-17
3/4	2-7/32	1100	SMA-8-11	SMA-15-11
3/4	2-7/32	1750	SMA-8-17	SMA-15-17
3/4	2-7/32	3600	SMA-8-36	SMA-15-36
15/16	2-3/4	1750	SMA-9-17	SMA-16-17
1	2-3/4	1100	SMA-10-11	SMA-16-11
1	2-3/4	1750	SMA-10-17	SMA-16-17
	2-3/4	3600		SMA-16-36
1-3/8	3-1/2	1750	SMA-200-17	SMA-17-17
1-1/2	3-1/2	1750	SMA-13-17	SMA-17-17
4-5/16		1100		SMA-33-11
4-5/16		1750		SMA-33-17



SMA-N

COUNTERSHAFT & SLINGER LIP OIL SEALS

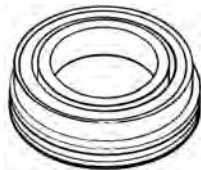

SMA-O

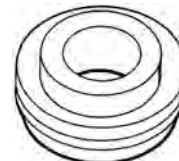

SMA-P

PHOTO REF	FRAME SIZE	GEARHEAD TYPE	REMARKS	PART NUMBER
O	56-5800-3000	SP-DP-RC-RW	(Output) Type M. This is a Type M Seal: supercedes all previous copper diaphragm seals and must be used with special lapped face bearings.	SMA-107
O	7400-4000-203-204	SP-RC-RW	(Output) Type M. This is a Type M Seal: supercedes all previous copper diaphragm seals and must be used with special lapped face bearings.	SMA-109
O	7400-4000-203-204	SP-RC-RW	(Output) Type DS. Type DS seals can be identified by three equally spaced 1/16" holes drilled in casting of seal bore.	SMA-154
P	5200-2900 56-5800-3000	SP-DP-RC-RW	(Input) Open & Enclosed, Fan Cooled & Class 11, Group G. Use 203736 clamp for SP-DP-RC, 203783 for RW	SMA-106
P	7400-4000-203-204	SP-DP-TP-RC-RW	Open & Enclosed, Fan Cooled & Class 11, Group G	SMA-110

GEARHEAD TYPE - SP = Single Parallel,
DP = Double Parallel,
TP = Triple Paralle,
RC = Right Angle Combination,
RW = Right Angle WormGear

TORQ MOTOR PARTS

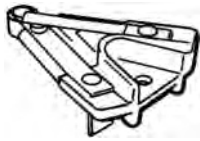

SAW-A

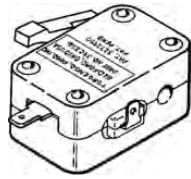

STQ-E

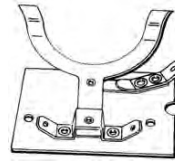

HEM-A

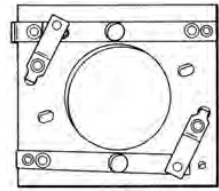

HEM-B

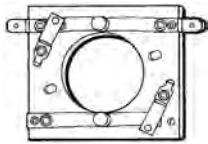

HEM-C

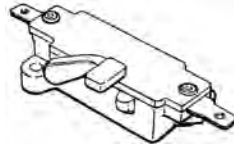

SHO-A



STQ-F

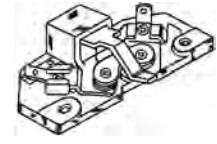

SBA-F

PHOTO REF.	CONTACTS		MOUNTING HOLES C-TO-C (IN.)	PLATE SIZE		SPADES			I.D. (IN.)	NOTES	PART NUMBER
	N.O.	N.C.		WIDTH (IN.)	LENGTH (IN.)	FRONT	BACK	STUDS			
SAW-A	1	-	-	-	-	2	-	-	-	Torq Replacement for SAW-25	STQ-25
STQ-E	1	-	1-5/8 (1-7/8" diag.)	1-5/16	2-3/32	2	-	-	-	Dustite switch 1" high	SCN-452
HEM-A	1	-	1-7/8	1-1/2	2-7/16	3	-	-	-	-	SKC-46
HEM-B	1	-	1-7/8	2-3/8	2-1/2	-	-	-	1-3/8	Metal contact pads	SOH-55
HEM-B	1	1	1-7/8	2-3/8	2-1/2	-	-	-	1-3/8	Metal contact pads	SOH-58
HEM-C	1	-	1-7/8	2-3/8	2-9/16	2	-	-	1-13/32	-	SOH-59
SHO-A	1	-	1-7/8	3/4	2-3/16	2	-	-	-	-	SHO-15
STQ-F	1	-	2-1/8	2-15/32	2-15/32	-	-	-	1	Used on Asian Import Motors	STQ-500
SBA-F	2	-	2-1/2	3-1/4	1-5/8	2	-	-	-	182-184,213-215	SBA-122
SDO-C	2	1	2-9/16 X 2-3/4	2-1/2	3-1/2	5	-	-	1-11/16	-	-
SDO-13											
STQ-A	2	-	2-9/16 X 2-3/4	2-1/2	3-1/2	4	-	-	1-11/16	Includes Removeable Jumper	STQ-200
SFW-A	1	-	2-5/8	1-1/2	3	3	-	-	-	-	SFW-6
SFW-B	1	-	2-5/8	1-15/32	3-9/16	3	-	-	-	-	SFW-9
HEM-D	2	1	2-11/16	3-1/16	3-7/16	5	-	-	1-15/16	-	SJH-29
STQ-B	2	-	2-11/16 X 2-3/4	3-1/16	3-1/2	4	-	-	1-15/16	Includes Removeable Jumper	STQ-250
SBA-D	2	2	2-3/4	2-1/2	3-7/16	5	-	-	1-11/16	-	SMR-94
SLS-B	-	1	2-3/4	2-1/2	3-29/64	2	-	-	1-11/16	-	SLS-13
SLS-C	-	2	2-3/4	2-1/2	3-29/64	2	-	-	1-11/16	Metal jumper bar	SLS-15
SLS-D	1	2	2-3/4	2-1/2	3-29/64	5	-	-	1-11/16	-	SLS-26
SLS-E	2	1	2-3/4	2-1/2	3-29/64	4	-	-	1-11/16	-	SLS-27
STQ-C	2	-	2-3/4	3-1/4	3-7/8	4	-	-	2-1/4	Metal jumper installed	STQ-300
HEM-F	2	-	3-3/8	3-1/4	3-7/8	-	-	-	2-29/32	-	SKC-39
SBA-H	2	-	3-3/8	3-7/8	3-7/8	4	-	-	2-29/32	Torq Replacement for SBA-66	STQ-400

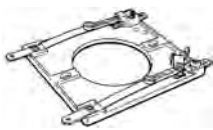

SDO-C

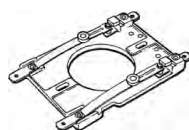

STQ-A

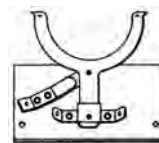

SFW-A

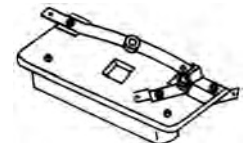

SFW-B

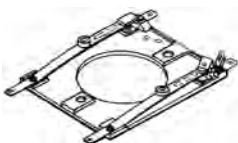

HEM-D

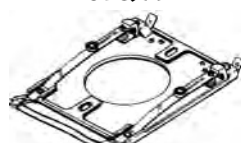

STQ-B

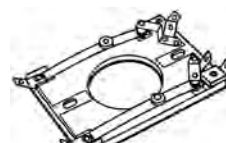

SBA-D

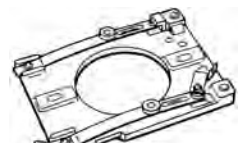

SIS-B

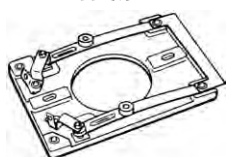

SLS-C



SLS-D

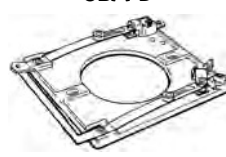

SIS-E



STQ-C

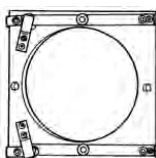

HEM-F

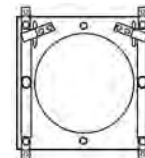

SBA-H

U.S. ELECTRIC MOTOR PARTS

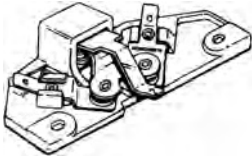

SUS-A

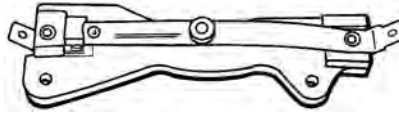

SUS-B



SUS-C

PHOTO REF.	CONTACTS		MOUNTING HOLES C-TO-C (IN.)	PLATE SIZE		SPADES		STUDS	I.D. (IN.)		PART NUMBER
	N.O.	N.C.		WIDTH (IN.)	LENGTH (IN.)	FRONT	BACK		NOTES		
SUS-A	1	-	2-3/4 & 3-3/16	2-1/4	3-9/16	2	-	-	-	-	SUS-36
SUS-B	1	-	3	1-3/16	3-7/8	2	-	-	-	-	SUS-32
SUS-C	2	-	3	1-5/8	3-3/4	2	-	-	-	-	SUS-35

PROGRESSIVE MOUNT RING LISTING



MR-A



MR-B

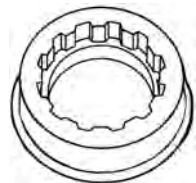

MR-E

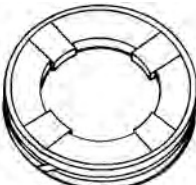

MR-F

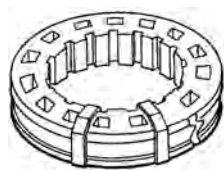

MR-I



MR-P



MR-Q

I.D. A (IN.)	I.D. B (IN.)	MAT.	O.D. (IN.)	MAT. THICK (IN.)	PHOTO REF.	UOM	PART NUMBER
1-3/16	1-3/8	R	1-3/4	R 1/2	MR-B	Ea.	SRE-80986
1-3/16	1-3/8	R	1-3/4	R 1/2	MR-B	Ea.	SRE-80125
1-5/16	1-9/16	R	1-13/16	M 5/16	MR-A	Ea.	STK-1220
1-15/32	1-9/16	R	2-1/16	M 7/16	MR-A	Ea.	SBA-115
1-1/2	1-21/32	R	2-1/2	R 1/2	MR-B	Ea.	SRE-80622
1-9/16	1-11/16	R	2-1/4	M 7/16	MR-D	St/2	STK-1255
1-9/16	1-3/4	R	2-1/4	M 3/8	MR-C	Ea.	SWH-352
1-9/16	1-3/4	R	2-1/2	M 13/8	MR-C	Ea.	SWH-451
1-9/16	1-25/32	R	2-1/4	P 1/2	MR-D	St/2	WD-KIT 183
1-19/32	1-25/32	R	2-1/2	P 3/8	MR-C	Ea	SWH-521
1-9/16	1 11/16	R	2-1/2	M 7/16	MR-D	St/2	STK-1182
1-9/16	1-25/32	R	2-1/2	R 1/2	MR-B	St/2	WD-KIT 186
1-9/16	1-25/32	R	2-1/2	P 1/2	MR-D	St/2	WD-KIT 184
1 11/16	1-7/8	R	2-1/2	M 1/2	MR-A	Ea.	SWH-298

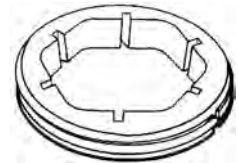

MR-C

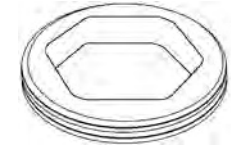

MR-D

NOTCH BORE MOUNT RINGS

I.D. A (IN.)	I.D. B (IN.)	MAT.	O.D. (IN.)	MAT. THICK (IN.)	PHOTO REF.	UOM	PART NUMBER
1-7/16	1-3/4	R	2-1/4	M 3/8	MR-K	St/2	SMR-125
1-7/16	1-3/4	R	2-1/2	M 3/8	MR-K	St/2	SMR-126
1-9/16	1-11/16	R	2-1/4	M 3/8	MR-I	Ea.	SGE-1109
1-9/16	1-11/16	R	2-1/2	M 3/8	MR-I	Ea.	SGE-1035
1-9/16	1-11/16	R	2-1/2	M 3/8	MR-G	Ea	SGE-1110
1-5/8	1-7/8	R	2-1/2	M 5/16	MR-H	Ea.	SGE-1202
1-11/16	1-29/32	R	2-1/2	R 1/2	MR-J	St/2	WD-KIT 185
1-11/16	1-31/32	R	2-1/4	M 3/8	MR-H	Ea.	SGE-761
1-11/16	1-31/32	R	2-1/2	M 3/8	MR-H	Ea.	SGE-749
1-11/16	1-31/32	R	2-1/2	R 7/16	MR-E	E.a	SGE-750
1-17/32	1-21/32	R	2-1/2	M 1/2	MR-F	St/2	SEM-210

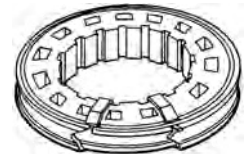

MR-G

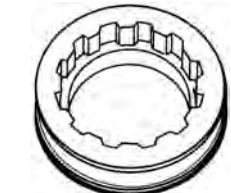

MR-H

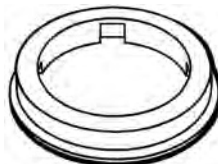

MR-J

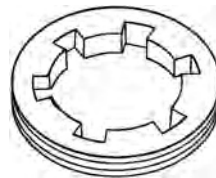

MR-K

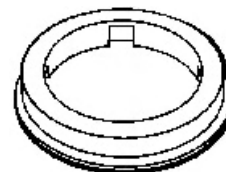

MR-L

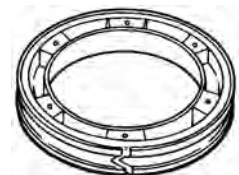

MR-M

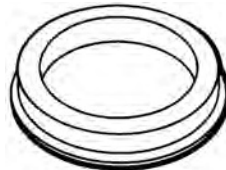

MR-N

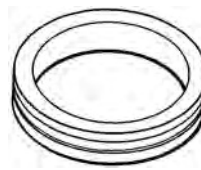

MR-O

ROUND BORE MOUNT RINGS

I.D. (IN.)	MAT.	O.D. (IN.)	MAT. THICK (IN.)	PHOTO REF.	UOM	PART #
1-9/32	R	1-13/16	R 3/8	MR-L	St/2	WD-KIT 187
1-9/32	M	1-13/16	M 5/16	MR-O	St/2	WD-KIT 180
1-15/32	M	2-1/16	M 7/16	MR-Q	Ea.	SBA-123
1-15/32	M	2-1/2	M 3/8	MR-R	St/2	SBG-12
1-15/32	M	2-1/2	M 3/8	MR-R	Ea.	SBG-RIB-MTG
1-9/16	M	2-1/2	M 3/4	MR-P	Ea.	SGE-1038
1-5/8	M	2-1/4	M 3/8	MR-M	Ea.	SGE-581
1-5/8	M	2-1/4	M 5/16	MR-S	St/2	SMR-72
1-5/8	M	2-1/2	M 5/16	MR-S	St/2	SMR-70
1-11/16	M	2-1/4	M 5/16	MR-Q	Ea.	SCN-481
1-11/16	M	2-1/2	M 5/16	MR-Q	Ea.	SCN-497
1-11/16	M	2-1/2	M 7/16	MR-R	St/2	SBG-31
1-11/16	M	2-1/2	P 7/16	MR-O	Ea.	SCN-106
1-7/8	M	2-1/2	M 7/16	MR-M	Ea.	SGE-575
2-1/8	M	3-1/2	M 1/2	MR-Q	St/2	SBG-32



MR-R



MR-S

SHOP EQUIPMENT

WINDING MACHINES



ARMATURE COIL EQUIPMENT, INC.

WINDING HEADS

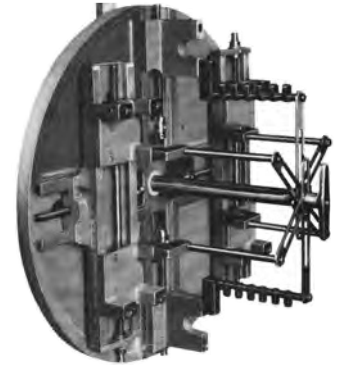
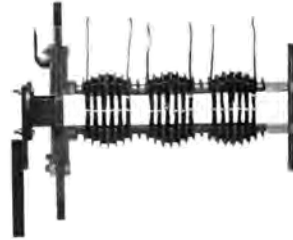

ARMATURE COIL EQUIPMENT, INC.

DYNAMOMETERS



AW DYNAMOMETER, Inc.



BALANCING MACHINES

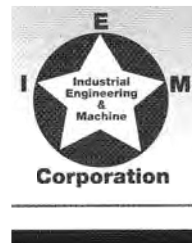
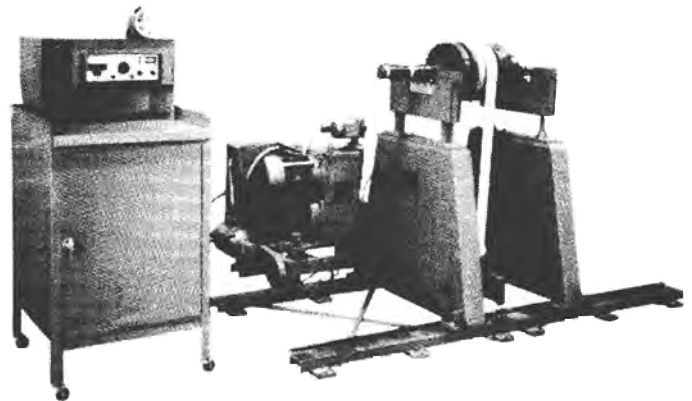

Division of I.E.M.

The equipment shown here is only a representation of the shop equipment that we represent. Please contact your sales representative for detailed information.

SHOP EQUIPMENT

BAKE OVENS

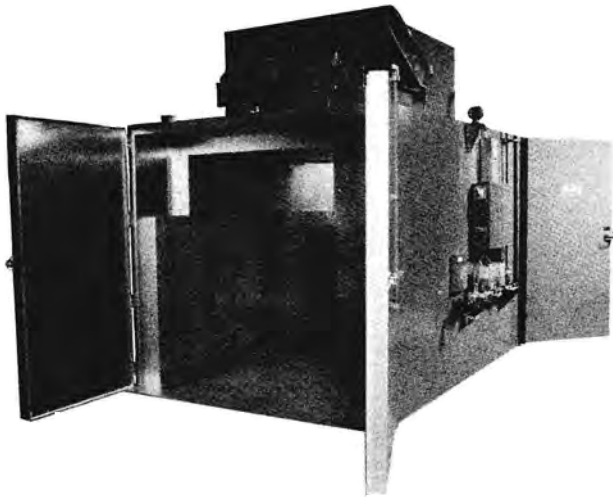

BAYCO[®]
OVENS

ENTERPRISES
EQUIPMENT MANUFACTURERS

SII

STEELMAN
INDUSTRIES, INC

BURN OFF OVENS



POLLUTION
CONTROL
PRODUCTS
TM REG. U.S. PAT. OFFICE.

JEMS

TENSION DEVICES AND DEREELERS



ENTERPRISES
EQUIPMENT MANUFACTURERS

PRJ
EQUIPMENT CO.
POTTER RAYFIELD & JAMES



ace
ARMATURE COIL EQUIPMENT, INC.

ETS

ESSEX

WIRE RACK



ace
ARMATURE COIL EQUIPMENT, INC.

PRJ
EQUIPMENT CO.
POTTER RAYFIELD & JAMES

The equipment shown here is only a representation of the shop equipment that we represent. Please contact your sales representative for detailed information.

SHOP EQUIPMENT

PULLERS



POSI LOCK PULLER, INC.
gear and bearing puller

COIL CUT-OFF



DOUGLASS INDUSTRIES, INC.

EPOXYLITE®
S & RED POINT EQUIPMENT



SPRAY BOOTHS

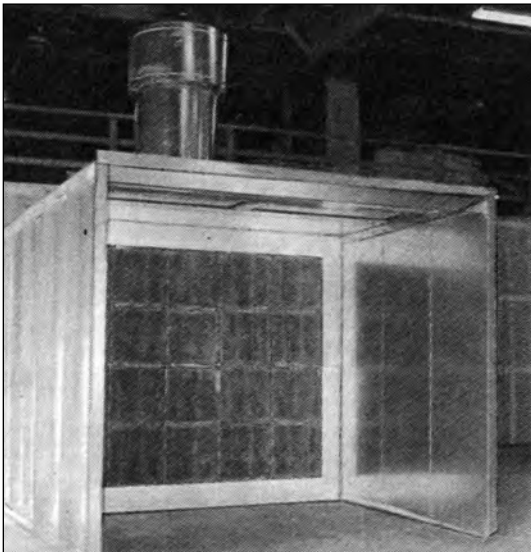

VIKING™
SPRAY BOOTHS & FRAME MACHINES

SAND BLASTERS



ECONOLINE

The equipment shown here is only a representation of the shop equipment that we represent. Please contact your sales representative for detailed information.

SHOP EQUIPMENT

COIL FORMING EQUIPMENT

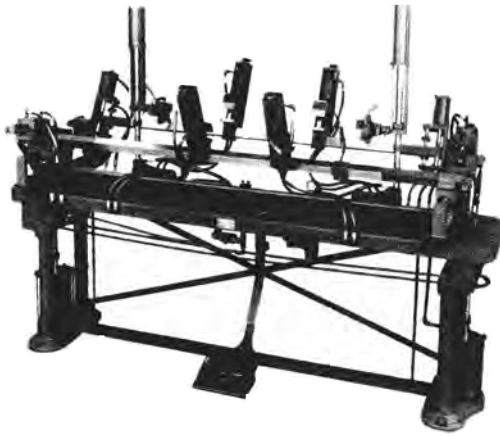

PARTS WASHERS

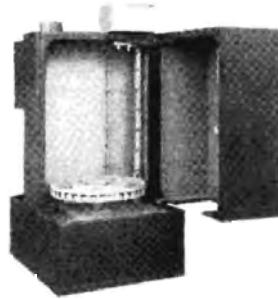

TEST CENTERS AND TEST EQUIPMENT

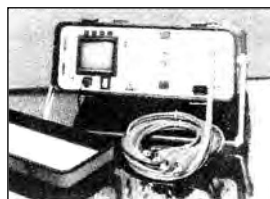

The equipment shown here is only a representation of the shop equipment that we represent. Please contact your sales representative for detailed information.

SHOP EQUIPMENT

VACUUM IMPREGNATION SYSTEMS

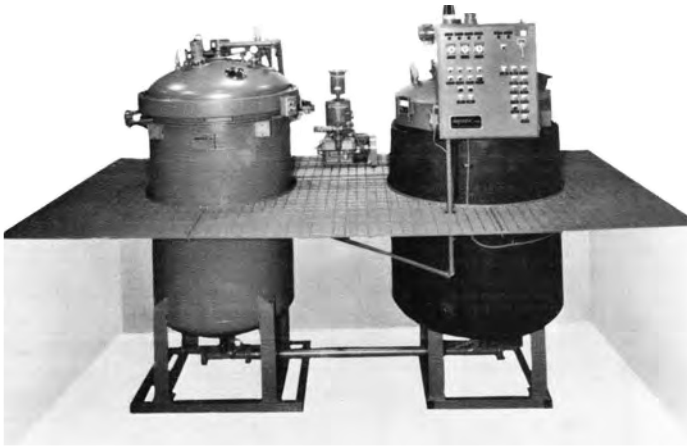

DIP TANKS

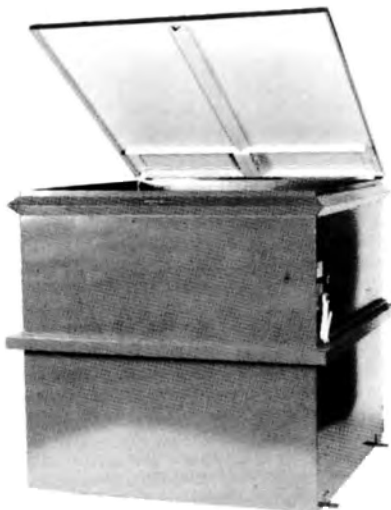

CUTTERS AND SHEARS



The equipment shown here is only a representation of the shop equipment that we represent. Please contact your sales representative for detailed information.

INDEX OF SUPPLIERS

NAME	PAGE
3M	22,29,47,48,54,56, 102,103
A O SMITH CORPORATION	57-60,65-70,72,121-125
ACTIVE INDUSTRIES	19
ADVANCED FIBER TECHNOLOGIES	30
A E M C	168
AERO-DYNAMICS CORPORATION	107
ALLIS CHALMERS	57-60
AMPROBE INSTRUMENT	168
ARDEN FASTENERS	11,104
ARMATURE COIL EQUIPMENT	165-166,168
ASSOCIATED SPRING-RAYMOND	83
AVO BIDDLE	168
A W DYNAMOMETER	165
A W SPERRY	168
BAKER	168
BALDOR	57-60,65-70,72,126
BAYCO	166
BEDFORD MATERIALS	5,6,16
BELDEN	23,25-27
BELL & GOSSETT	65-70,72,89,127,128
B E M	168
BENCHMARK SOUTH	85
BENNER NAWMAN INC	104
BENTLEY HARRIS	21,22
BODINE	57-60,65-70,72,129
BOSTIK	55
BURNLEY BATTERY&MFG CO	28
CALPICO INC	54
CAM INDUSTRIES	118
CANFIELD TECHNOLOGIES	28
CAROLINA NARROW FABRIC	9,11
CENTURY/MAGNETEK INC	57-60,65-70,72,156-157
CHAMPLAIN CABLE	24,26
CLAUSS CUTLERY CO	104
CMI	20
CONE MOUNTER CO INC	114
CORSICANA INDUSTRIAL SALE	57,58
COTTRELL PAPER	6
CRATEX BRIGHTBOY ABRASIVE	102
CROWN INDUSTRIAL PRODUCTS	103,107,165,168
DELCO	57-60
DEWALT	130
DIAMOND U PRODUCTS INC.	104
DOERR	57-60,65-70,72,130
DOUGLASS INDUSTRIES, INC.	167
DOW CORNING	39,43,49-51,54
DUNSTONE	32
DuPONT	5,16
DYNA-BAL	165
ECONOLINE	167
ECOLINK, INC	4
ELECTRA	65-70,72,131

NAME	PAGE
EMERSON	65-70,72,131,132
EPOXYLITE	167,169
ESSEX BROWNELL	17-19
ESSEX LEAD WIRE	24-26
ESSEX MAGNET WIRE	12-15,120,166
ESSEX VARNISH	35,38
E T S	166
FABRICO	16-18
FAMOUS LUBRICANTS INC	33
FIBERTEK	9,30-32
FLINT & WALLING INC	65-70,72,132
FOSTER ELECTRIC	85
FRANK N WOOD CO	119
FRANKLIN	57-60,65-70,72,133-135
GARLAND MFG CO	106
GENERAL ELECTRIC	57-60,65-72,87-89, 135-151
GEORG MILLER OF AMERICA	4
GLASTIC	7,8,20
GLYPTAL	44
GRAND TOOL SUPPLY CORP.	104
GRAY MILLS	168
GUDEBROD	30
H F HANSCOM CO	11,105
HAMPSHIRE SPECIALTY PRODUCTS	17
HARTLINE PROD CO INC	54
HESGON	9
HOBART	152
HOWELL	152
HYSOL	55
IDEAL INDUSTRIES INC.	104,105,108-110,119
I E S C	167
IMPREX	169
INDUCTOR	165
INDUSTRIAL ENGINEERING & MACHINE	165
INDUSTRIAL ENG SALES CORP	111
INSULSAFE TEXTILES, INC.	31
INTERNATIONAL PAPER	7,8
IRON FIREMAN	153
JACK & HEINTZ	65-70,72
JACOBS	108
JACQUES SHEARS BY L. HARDY CO	169
JAMES MORTON INC	114
JENKINS ELECTRIC COMPANY	168
JEMS	166
JOHN C. DOLPH	33-39,41-45,55
JW HARRIS CO INC	28
KB ELECTRONICS INC	95
KBC	73,74
KINGSTON CONLEY	65-70,72
KLEER FLO CO	4,168
KREMPER	10

LELAND GAS PUMP SWITCHES

NAME	PAGE	NAME	PAGE
KRYLON	46	SQUARE D	97,98
KUKKO	111-113,167	S W ENTERPRISES	165-168
LAYCOCK SYSTEMS INC.	103,104,165	SIMPSON	168
LECTROMAT INCORPORATED	31	STAHL'S SEVENTY'S	103
LEESON ELECTRIC CORP	57-60,65-70,72,89,154	STANDARD TYTAPE CO	11
LELAND	155	STANLEY PROTO IND TOOLS	106
LELAND FARADAY	65-70,72,90,98	STEARNS/REXNORD	92,93
LIMA	155	STEELMAN INDUSTRIES	166
LINCOLN	57-60	SUFLEX	21,22
LOUIS ALLIS	57-60	SYNFLEX ELEKTRO TOOL GMBH	59,63
LUDLOW TEXTILES CO INC	30	TAR HEEL MICA COMPANY	9
MACALLEN	9	TECO	57-60
MAG MACHINE COMPANY	104	TENNSMITH	169
MAGNETEK	57-60,65-70,72,156-157	TEXAS INSTRUMENTS INC.	91,99,101
MARATHON	57-60,65-70,72,158-159	THE ERASER COMPANY INC	105
MART	168	THE JACOBS MFG COMPANY	108
MARTINDALE ELECTRIC CO	103,104,107,115-118	THE LINDERME TUBE COMPANY	28
MASTERRELIANCE	57-60,65-70,72,160-161	THE MILL-ROSE COMPANY	104
MASTER LUBRICANTS	71	TORQ CORPORATION	65,162
M B M CORPORATION	169	TOSHIBA	57-60
MINCO	100	TRAVIS MFG CORP	108
M-M&M	20	TURTLE & HUGHES, INC	54
MOLEX-ETC	29	TYTON HELLERMANN	11
MOXNESS PRODUCTS INC	28	US ELECTRIC	57-60,65-70,72,163
MRC TECHNOLOGY	94	US SAMICA	10
MUELLER ELECTRIC CO	106	USA TOLERANCE RINGS	71
MUTUAL INDUSTRIES	9	VALLEY	65-70,72
NACHI	73-76	VANGUARD	4,44,45,54,86
NATIONAL BAND & TAG CO.	56	VIKING	167,169
NTN	73-76	W H BRADY COMPANY	56
NVF COMPANY	7	WAGNER	65-70,72
OHIO	65-70,72	WEAR-FLEX SLINGS	108
P.D. GEORGE	36-39,41	WESTERN FILAMENT	30,31
PEERLESS	65-70,72	WESTINGHOUSE	57-60,65-70,72,121-125
PEERLESS TOOL	118	WHEELER INDUSTRIES	77-82
PEI	10	WHITE ROGERS	90,96,97
PENN FIBRE & SPECIALTY CO.	83	WINDSOR STEVENS	7
PERMABOND	52,53		
PERMACEL	47,48		
PHENIX TECHNOLOGIES	168		
PIQUA	65-70,72		
POLLUTION CONTROL PRODUCTS	166		
POSILOCK	167		
POTTER RAYFIELD & JAMES	165-166,168		
PPI	32		
PRECISE INDUSTRIES	71		
R B M	90		
RANBAR ELECTRICAL MAT INC	33-36,39-45		
RECO	114		
RELAY & CONTROLS CORP	11,85		
RELIANCE	57-60,65-70,72,160-161		
ROWE INDUSTRIES	48		
SPRAYON	33,39		

Essex Group, Inc.

Standard Terms and Conditions of Sale

1. ACCEPTANCE, WAIVER, MODIFICATION, INTERPRETATION AND CONSTRUCTION

Orders which are accepted, and contracts that are formed, are accepted or formed at Seller's offices on the basis of and strictly limited to the Seller's standard terms and conditions of sale, which Buyer is deemed to consent to as a condition thereto and which shall control over any contrary or additional terms and conditions on any purchase order or other document of Buyer, which additional terms and conditions are hereby objected to and to which Seller shall not be bound. Waiver of any term or condition of sale shall not constitute waiver of any other term or condition or legal remedy of Seller. Any act by Buyer of confirmation of any transaction contemplated hereby, including any order issued in response to a quote of Seller, shall constitute Buyer's acceptance of Seller's terms and conditions. No modification of any order or contract shall be binding unless in writing signed by both parties hereto. Orders and contracts shall be interpreted in accordance with, and the construction hereof shall be governed by, the laws of the State of Indiana, United States of America. Captions as used herein are for convenience or reference only and shall not be deemed or construed as in any way limiting or extending the meaning of any terms and conditions.

2. TITLE, DELIVERY, RISK OF LOSS AND SHIPPING

Title to and risk of loss of all goods sold hereunder shall pass to Buyer upon their delivery, F.O.B. Seller's factory (unless a different F.O.B. point is otherwise agreed to and accepted) to any agent of Buyer, including a common carrier or warehouse, as hereinafter provided. Wherever transportation rates and carrier's liability for damage depend upon the value of the shipment as declared by shipper, Seller will declare such value as will entitle Buyer to have goods shipped at the lowest permissible transportation rates unless otherwise instructed in writing by Buyer. Buyer will furnish written destination instructions for all goods as promptly as possible. Seller shall for the account and at the expense and risk of Buyer arrange for shipment of the goods by a carrier of its own selection to Buyer's destination. In the absence of destination instructions, Seller may at Buyer's expense and with notice to Buyer, warehouse the goods in a reasonably suitable manner. Seller shall not be liable for loss or damage attributed to negligence either in selection of the carrier or the warehouse or in agreeing with either of them to contract terms on Buyer's behalf.

3. PRICE AND PAYMENT

Unless otherwise specified, all orders or contracts accepted will be invoiced at Seller's prices in effect on the date of shipment, which Buyer agrees to pay. Unless otherwise specified, payment terms are net 30 days, and overdue accounts shall accrue charges at a rate of 1.5% (.015) per month or the maximum legal rate, whichever is less. Credit and delivery shall be subject to Seller's approval and Seller reserves the right to alter the terms and fix a limit of credit. Each order or contract shall be treated as a distinct contract but if Buyer shall fail to fulfill the terms of payment, Seller may without prejudice to any other lawful remedy defer further shipments, and/or cancel any order or contract. Buyer shall be liable to Seller for all costs and fees, including attorneys' fees, which Seller may reasonably incur in any actions by Seller taken to collect on any overdue account of Buyer.

4. INSPECTION

If upon receipt of the goods by Buyer at destination the same shall appear not to conform to this order or contract, Buyer shall within thirty (30) days after receipt thereof notify Seller of such condition and afford Seller a reasonable opportunity to inspect the goods and make any appropriate adjustment or replacement. The remedies afforded Buyer under the paragraph hereof entitled "LIMITED WARRANTIES, REMEDIES AND LIMITATIONS" shall be the exclusive remedies for defective goods whether or not discovered upon inspection by Buyer. Buyer shall not delay payment for the goods pending their inspection.

5. LIMITED WARRANTIES, REMEDIES AND LIMITATIONS

a. Defective Goods

Seller warrants to Buyer that at the time of delivery the goods sold hereunder will be free from defects in design, material and manufacture and will conform substantially to Seller's applicable specifications as stipulated in the order or contract. Seller's liability and Buyer's remedy under this warranty are strictly limited to the refund of purchase price, repair or replacement, at Seller's sole option, of goods or materials sold which are returned to Seller and which are shown to Seller's reasonable satisfaction to have been defective provided that written notice of the defect shall have been given by Buyer to Seller within sixty (60) days of delivery of such goods by the Seller. Transportation charges to and from Seller's location for the return of defective goods to Seller and their re-shipment to Buyer and the risk of loss thereof will be borne by Buyer. If services or data are to be furnished hereunder, Seller warrants to Buyer that such services will be performed or such data prepared in a good workmanlike manner. Seller's liability and Buyer's remedy under this warranty are limited to the correction of such services or data as are shown to Seller's reasonable satisfaction to have been defective, provided that written notice of such defective services or data shall have been given by Buyer to Seller within thirty (30) days after the performance of such services or delivery of such data by Seller.

b. Title

Seller warrants to Buyer that it will convey good title to the property sold. Seller's liability and Buyer's remedy under this warranty are strictly limited to the removal of any title defect or, at the sole option of the Seller, to the replacement of the goods or parts thereof which are defective in title, provided however, that the rights and remedies of the parties with respect to patent infringement shall be limited to the provisions of subparagraph c. below.

c. Patent Infringement

Seller shall conduct, at its own expense, the entire defense of any claim, suit or action alleging that, without further combination, the use or resale by Buyer or any subsequent purchaser or user of the goods delivered hereunder, directly infringes any United States patent, but only on the conditions that, (1) Seller receives prompt written notice of such claim, suit or action, full opportunity and authority to assume the sole defense thereof including settlement and appeals, and all information available to Buyer and defendant for such defense, (2) said goods are made according to a specification or design furnished by Seller, or if a process patent is involved, the process performed by the goods is recommended in writing by Seller, and (3) the claim, suit or action is brought against Buyer or one expressly indemnified by Buyer. Provided all three of the foregoing conditions have been met, Seller shall, at its own expense, either settle said claim, suit or action or shall pay all damages excluding consequential damages and costs awarded by the court therein and, if the use or resale of such goods is finally enjoined, Seller shall, at Seller's option, procure for defendant the right to use or resell the goods, replace them with equivalent non-infringing goods, modify them so they become non-infringing but equivalent, or remove them and refund the purchase price (less a reasonable allowance for use, damage or obsolescence). No indemnity is granted by Seller under the patents of any nation other than that specified above, nor with

respect to any of the goods or components thereof manufactured according to a specification or design of anyone other than Seller. If a claim, suit or action is based on a specification or design furnished by Buyer or on the performance of a process not recommended in writing by Seller, or on the use or sale of the goods delivered hereunder in combination with other goods not delivered to Buyer by Seller, Buyer shall indemnify and save Seller harmless therefrom.

d. Exclusive Warranties and Remedies

THE FOREGOING WARRANTIES ARE EXCLUSIVE AND ARE GIVEN AND ACCEPTED IN LIEU OF (a) ANY AND ALL OTHER WARRANTIES EXPRESS OR IMPLIED, INCLUDING WITHOUT LIMITATION ANY WARRANTIES OF MERCHANTABILITY OR FITNESS FOR A PARTICULAR PURPOSE OR ARISING OUT OF THE CONDUCT OF THE PARTIES, AND (b) ANY OBLIGATION, LIABILITY, RIGHT, CLAIM OR REMEDY FOR SELLERS NEGLIGENCE, ACTUAL OR IMPUTED. The remedies of the Buyer for breach of any warranty arising hereby, expressed or implied, or by operation of law, or for breach of any duty of Seller, expressed or implied or arising out of any conduct of the parties, shall be strictly limited to those provided herein to the exclusion of any and all other remedies including, without limitation, claims for incidental or consequential damages. No agreement varying or extending the foregoing warranties, remedies or these limitations will be binding upon Seller unless in writing, signed by a duly authorized executive officer of Seller.

6. EXCUSABLE DELAYS

Buyer acknowledges that the goods and/or services called for hereunder are to be manufactured or provided by or for Seller to fulfill this order or contract and that the delivery date(s) is (are) based on the assumption that there will be no delay due to causes beyond the reasonable control of Seller. Seller shall not be charged with any liability for delay or nondelivery when due to delays of suppliers, acts of God or the public enemy, compliance in good faith with any applicable foreign or domestic governmental regulation or order, whether or not it proves to be invalid, fires, riots, labor disputes, unusually severe weather or any other cause beyond the reasonable control of Seller. To the extent such causes actually retard deliveries on the part of the Seller, the time for performance shall be extended for as many days beyond the date thereof as is required to obtain removal of such causes. This provision shall not, however, relieve Seller from using its best efforts to avoid or remove such causes, and continue performance with reasonable dispatch whenever such causes are removed.

7. TAXES

In addition to the agreed purchase price of the goods and/or services called for hereunder any and all taxes (not including any U.S. income or excess profit taxes attributable to Seller) which may be imposed by any taxing authority, arising from the sale, delivery or use of the goods and/or the furnishing of the services hereunder and for which Seller may be held responsible for collection or payment, either on its own behalf or that of Buyer, shall be paid by Buyer to Seller upon Seller's demand.

8. FINANCIAL RESPONSIBILITY OF BUYER

If before completion of performance of any order or contract by Seller, a receiver or trustee is appointed for any of Buyer's property, or Buyer be adjudicated or voluntarily becomes a bankrupt under any bankruptcy, dissolution or re-organization laws or similar legislation, or if Buyer becomes insolvent or makes an assignment for the benefit of creditors, or an execution be issued pursuant to a judgement rendered against Buyer, or should Buyer be unable or refuse to make payment to Seller in accordance with any of its obligations to Seller, Seller may at its option in any of such events terminate any order or contract by giving to Buyer a written notice of its intention so to do and Seller shall thereupon be relieved of any further obligation to Buyer and Buyer shall reimburse Seller for its termination costs and expenses and a reasonable allowance for profit.

9. CANCELLATIONS AND RETURNS

Orders may be canceled, and goods may be returned for credit, only upon the prior approval of Seller and upon terms protecting Seller from loss.

10. CHANGES

Seller may at its option modify Buyer's order where necessary by making any of the following changes: (a) substituting the latest or correct part number or part description for the part number or part description set forth on the order; (b) substituting Seller's prices in effect as applicable to the order for the prices set forth in Buyer's order; (c) substituting an estimated delivery schedule which is reasonable (considering Seller's stock availability and lead time) for the delivery schedule set forth on the order; (d) correcting any serigraphical or typographical error on any document.

11. COMPLIANCE WITH FAIR LABOR STANDARDS ACT

Seller hereby certifies that all goods sold hereunder which are produced or manufactured in the United States of America are produced in compliance with the Fair Labor Standards Act of 1938, as amended (29 U.S. Code 201-219). All requirements as to the certificate contemplated in the October 26, 1949 amendment to the Fair Labor Standards Act of 1938 shall be considered as satisfied by this certification.

12. APPENDICES

Any appendix or other terms and conditions of the Seller as may be attached hereto, be on the reverse hereof, and/or be identified herewith are hereby incorporated and made a part of these terms and conditions. All orders or contracts shall be subject to such additional terms and conditions which shall control over any inconsistency with the terms and conditions stated herein.

13. ENTIRE AGREEMENT

The terms and conditions of this order or contract constitute the entire agreement between the parties hereto and shall supersede all previous communications, representations or agreements, either oral or written between the parties hereto with respect to the subject matter hereof.

14. CHANGES — PROCESS, MATERIAL AND PRODUCT DESIGN

Seller continually develops and uses new processes, materials and product designs in an effort to improve its products, while maintaining conformity to specifications. If your applications of our products rely upon any performance, dimensional or content criteria other than as required by the applicable specifications, you must conduct regular testing or evaluation of those specific products. Seller makes no warranty or representation of any nature that any material shipped conforms to any material of like product description as may have previously been delivered to you, except as to the applicable specifications.

Your Total Source

ESSEX® MAGNET WIRE

MOTOR LEAD WIRE

INSULATION

Flexibles

Rigids

US Samica Mica Products

Suflex

Sleeving

Electrical Tapes

LIQUID INSULATIONS

Varnish

Paints

Sealants

Adhesives

ELECTRIC MOTORS

Fractional HP

Integral HP

MOTOR REPLACEMENT PARTS

Switches

Brushes

Capacitors

Bearings

SHOP EQUIPMENT



ESSEX GROUP, INC.

Phone 800-774-4643 • Fax 800-768-9782