



CLICK ANYWHERE on THIS PAGE to  
BACKUP ELECTRICAL GENERATOR  
INSTALLATION & USE at  
[InspectApedia.com](http://InspectApedia.com)

# Installation and Owner's Manual

7, 10, 13 and 16kW Air-cooled,  
Automatic Standby Generators



Models: 005240, 005280 (6 kW NG, 7 kW LP)  
005241, 005281 (9 kW NG, 10 kW LP)  
005242, 005282 (13 kW NG, 13 kW LP)  
005243, 005244, (15 kW NG, 16 kW LP)  
005283, 005284

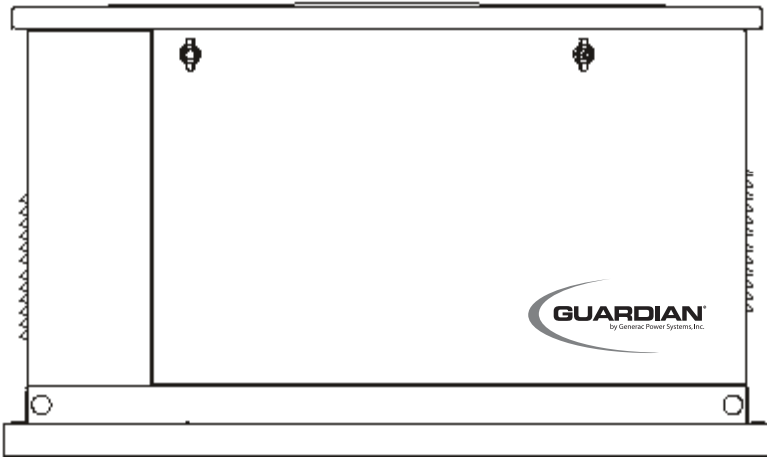

Not intended for use as Primary Power in place of utility or in  
life-support applications.



**! DANGER !**

**DEADLY EXHAUST FUMES. OUTDOOR INSTALLATION ONLY!**

## INTRODUCTION

Thank you for purchasing this model of the Guardian product line by Generac Power Systems Inc. This model is a compact, high performance, air-cooled, engine-driven generator designed to automatically supply electrical power to operate critical loads during a utility power failure.

This unit is factory installed in an all-weather, metal enclosure that **is intended exclusively for outdoor installation**. This generator will operate using either vapor withdrawn liquid propane (LP) or natural gas (NG).

### ◆ READ THIS MANUAL THOROUGHLY

If any portion of this manual is not understood, contact the nearest Authorized Dealer for starting, operating and servicing procedures.

Throughout this publication, and on tags and decals affixed to the generator, DANGER, WARNING, CAUTION and NOTE blocks are used to alert personnel to special instructions about a particular operation that may be hazardous if performed incorrectly or carelessly. Observe them carefully. Their definitions are as follows:

#### —▲ **DANGER** ▲—

After this heading, read instructions that, if not strictly complied with, will result in serious personal injury, including death, in addition to property damage.

#### —▲ **WARNING** ▲—

After this heading, read instructions that, if not strictly complied with, may result in serious personal injury or property damage.

#### —▲ **CAUTION** ▲—

After this heading, read instructions that, if not strictly complied with, could result in damage to equipment and/or property.

#### **NOTE:**

After this heading, read explanatory statements that require special emphasis.

**These safety warnings cannot eliminate the hazards that they indicate. Common sense and strict compliance with the special instructions while performing the service are essential to preventing accidents.**

Four commonly used safety symbols accompany the DANGER, WARNING and CAUTION blocks. The type of information each indicates follows:

▲ This symbol points out important safety information that, if not followed, could endanger personal safety and/or property of others.

▲ This symbol points out potential explosion hazard.

▲ This symbol points out potential fire hazard.

▲ This symbol points out potential electrical shock hazard.

The operator is responsible for proper and safe use of the equipment. The manufacturer strongly recommends that the operator read this *Owner's Manual* and thoroughly understand all instructions before using this equipment. The manufacturer also strongly recommends instructing other users to properly start and operate the unit. This prepares them if they need to operate the equipment in an emergency.

### ◆ CONTENTS

This manual contains pertinent owner's information, including warranty, electrical diagrams, exploded views and lists of repair parts, for these different models:

- 05240 & 05280 – 6 kW NG, 7 kW LP, single-cylinder GH-410 Engine
- 05241 & 05281 – 9.0 kW NG, 10 kW LP, V-twin GT-530 Engine
- 05242 & 05282 – 13 kW NG, 13 kW LP, V-twin GT-990 Engine
- 05243, 05244, 05283 & 05284 – 15 kW NG, 16 kW LP, V-twin GT-990 Engine

### ◆ OPERATION AND MAINTENANCE

It is the operator's responsibility to perform all safety checks, to make sure that all maintenance for safe operation is performed promptly, and to have the equipment checked periodically by an Authorized Dealer. Normal maintenance service and replacement of parts are the responsibility of the owner/operator and, as such, are not considered defects in materials or workmanship within the terms of the warranty. Individual operating habits and usage contribute to the need for maintenance service.

Proper maintenance and care of the generator ensures a minimum number of problems and keep operating expenses at a minimum. See an Authorized Dealer for service aids and accessories.

### ◆ HOW TO OBTAIN SERVICE

When the generator requires servicing or repairs, contact an Authorized Dealer for assistance. Service technicians are factory-trained and are capable of handling all service needs.

When contacting an Authorized Dealer about parts and service, always supply the complete model number and serial number of the unit as given on its data decal, which is located on the generator. See section "The Generator" for decal location.

**Model No.** \_\_\_\_\_ **Serial No.** \_\_\_\_\_

## AUTHORIZED DEALER LOCATION

To locate the nearest AUTHORIZED  
DEALER, please call this number:

**1-800-333-1322**

DEALER LOCATION INFORMATION  
CAN BE OBTAINED AT THIS NUMBER or visit  
[www.guardiangenerators.com](http://www.guardiangenerators.com).

**Introduction .....Inside Front Cover**

Read This Manual Thoroughly ..... IFC  
Contents..... IFC  
Operation and Maintenance ..... IFC  
How to Obtain Service..... IFC  
Authorized Dealer Locator Number ..... IFC

**Safety Rules .....2**

Standards Index..... 3

**Section 1 – General Information .....4**

1.1 Unpacking/Inspection ..... 4  
1.2 Protection Systems..... 4  
1.3 NEC Requirement for Arc Fault Circuit  
Interruption Breaker for Bedrooms ..... 4  
1.4 The Generator ..... 5  
1.5 Specifications ..... 6  
1.6 System Set LED ..... 7  
1.7 Fuel Requirements and Recommendations ... 7  
1.8 Fuel Consumption ..... 7  
1.9 Reconfiguring the Fuel System ..... 8  
1.10 Location ..... 9  
1.11 Battery Requirements..... 10  
1.12 Battery Installation..... 10  
1.13 The Battery ..... 11

**Section 2 – Post Installation Start-up  
and Adjustments .....12**

2.1 Before Initial Startup..... 12  
2.2 Check Transfer Switch Operation ..... 12  
2.3 Electrical Checks ..... 12  
2.4 Generator Tests Under Load ..... 13  
2.5 Checking Automatic Operation..... 13  
2.6 Adjusting the Fuel Regulator -  
7kW (Natural Gas Only)..... 13  
2.7 Engine Governor Adjustment ..... 14  
2.8 Voltage Regulator Adjustment..... 15

**Section 3 – Operation .....15**

3.1 Using the AUTO/OFF/MANUAL Switch ..... 15  
3.2 Automatic Transfer Operation..... 16  
3.3 Sequence of Automatic Operation ..... 16  
3.4 Manual Transfer Operation ..... 16  
3.5 Setting the Exercise Timer ..... 17  
3.6 Protection Systems..... 18

**Section 4 – Maintenance.....19**

4.1 Fuses ..... 19  
4.2 Checking the Engine Oil Level..... 19  
4.3 Changing the Engine Oil ..... 20  
4.4 Changing the Engine Air Cleaner..... 21  
4.5 Spark Plug(s) ..... 21  
4.6 Battery Maintenance..... 22  
4.7 Adjusting GH-410/GT-530/990  
Valve Clearance..... 22  
4.8 Cooling System ..... 23  
4.9 Attention After Submersion..... 23  
4.10 Corrosion Protection ..... 24  
4.11 Out of Service Procedure..... 24  
4.12 Service Schedule ..... 25

**Section 5 – Troubleshooting..... 26**

5.1 Troubleshooting Guide..... 26

**Section 6 – Notes .....27**

**Section 7 – Mounting Dimensions..... 30**

**Section 8 – Electrical Data ..... 31**

**Section 9 – Exploded Views and  
Parts Lists..... 42**

**Section 10 – Warranty ..... 68**



**⚠ SAVE THESE INSTRUCTIONS – The manufacturer suggests that these rules for safe operation be copied and posted near the unit's installation site. Safety should be stressed to all operators and potential operators of this equipment. ⚠**



### • WARNING:



- The engine exhaust from this product contains chemicals known to the state of California to cause cancer, birth defects or other reproductive harm.



### • WARNING:



- This product contains or emits chemicals known to the state of California to cause cancer, birth defects or other reproductive harm.

Study these SAFETY RULES carefully before installing, operating or servicing this equipment. Become familiar with this *Owner's Manual* and with the unit. The generator can operate safely, efficiently and reliably only if it is properly installed, operated and maintained. Many accidents are caused by failing to follow simple and fundamental rules or precautions.

The manufacturer cannot anticipate every possible circumstance that might involve a hazard. The warnings in this manual, and on tags and decals affixed to the unit are, therefore, not all-inclusive. If using a procedure, work method or operating technique the manufacturer does not specifically recommend, ensure that it is safe for others. Also make sure the procedure, work method or operating technique utilized does not render the generator unsafe.

## — ⚠ DANGER ⚠ —

- ⚠ Despite the safe design of this generator, operating this equipment imprudently, neglecting its maintenance or being careless can cause possible injury or death. Permit only responsible and capable persons to operate or maintain this equipment.
- ⚠ Potentially lethal voltages are generated by these machines. Ensure all steps are taken to render the machine safe before attempting to work on the generator.
- ⚠ Parts of the generator are rotating and/or hot during operation. Exercise care near running generators.



### GENERAL HAZARDS



- For safety reasons, the manufacturer recommends that the installation, initial start-up and maintenance of this equipment is carried out by an Authorized Dealer.
- The engine exhaust fumes contain carbon monoxide, which can be DEADLY. This dangerous gas, if breathed in sufficient concentrations, can cause unconsciousness or even death. This exhaust system must be installed properly, in strict compliance with applicable codes and standards. Following installation, do nothing that might render the system unsafe or in noncompliance with such codes and standards.
- Keep hands, feet, clothing, etc., away from drive belts, fans, and other moving or hot parts. Never remove any drive belt or fan guard while the unit is operating.
- Adequate, unobstructed flow of cooling and ventilating air is critical to correct generator operation. Do not alter the installation or permit even partial blockage of ventilation provisions, as this can seriously affect safe operation of the generator. The generator MUST be installed outdoors.
- When working on this equipment, remain alert at all times. Never work on the equipment when physically or mentally fatigued.
- Inspect the generator regularly, and contact the nearest Authorized Dealer for parts needing repair or replacement.
- Before performing any maintenance on the generator, disconnect its battery cables to prevent accidental start up. Disconnect the cable from the battery post indicated by a NEGATIVE, NEG or (-) first, then remove the POSITIVE, POS or (+) cable. When reconnecting the cables, connect the POSITIVE cable first, the NEGATIVE cable last.
- Never use the generator or any of its parts as a step. Stepping on the unit can stress and break parts, and may result in dangerous operating conditions from leaking exhaust gases, fuel leakage, oil leakage, etc.



** ELECTRICAL HAZARDS **

- All generators covered by this manual produce dangerous electrical voltages and can cause fatal electrical shock. Utility power delivers extremely high and dangerous voltages to the transfer switch as does the standby generator when it is in operation. Avoid contact with bare wires, terminals, connections, etc., while the unit is running. Ensure all appropriate covers, guards and barriers are in place, secured and/or locked before operating the generator. If work must be done around an operating unit, stand on an insulated, dry surface to reduce shock hazard.
- Do not handle any kind of electrical device while standing in water, while barefoot, or while hands or feet are wet. DANGEROUS ELECTRICAL SHOCK MAY RESULT.
- The National Electrical Code (NEC) requires the frame and external electrically conductive parts of the generator to be connected to an approved earth ground. Local electrical codes also may require proper grounding of the generator electrical system.
- After installing this home standby electrical system, the generator may crank and start at any time without warning. When this occurs, load circuits are transferred to the STANDBY (generator) power source. To prevent possible injury if such a start and transfer occur, always set the generator's AUTO/OFF/MANUAL switch to its OFF position before working on equipment and remove the 15A fuse from the generator control panel.
- In case of accident caused by electric shock, immediately shut down the source of electrical power. If this is not possible, attempt to free the victim from the live conductor. AVOID DIRECT CONTACT WITH THE VICTIM. Use a nonconducting implement, such as a dry rope or board, to free the victim from the live conductor. If the victim is unconscious, apply first aid and get immediate medical help.
- Never wear jewelry when working on this equipment. Jewelry can conduct electricity resulting in electric shock, or may get caught in moving components causing injury.

** FIRE HAZARDS **

- For fire safety, the generator must be installed and maintained properly. **Installation must always comply with applicable codes, standards, laws and regulations.** Adhere strictly to local, state and national electrical and building codes. Comply with regulations the Occupational Safety and Health Administration (OSHA) has established. Also, ensure that the generator is installed in accordance with the manufacturer's instructions and recommendations. Following proper installation, do nothing that might alter a safe installation and render the unit in noncompliance with the aforementioned codes, standards, laws and regulations.

- Keep a fire extinguisher near the generator at all times. Extinguishers rated "ABC" by the National Fire Protection Association are appropriate for use on the standby electric system. Keep the extinguisher properly charged and be familiar with its use. Consult the local fire department with any questions pertaining to fire extinguishers.

** EXPLOSION HAZARDS **

- Do not smoke around the generator. Wipe up any fuel or oil spills immediately. Ensure that no combustible materials are left in the generator compartment, or on or near the generator, as FIRE or EXPLOSION may result. Keep the area surrounding the generator clean and free from debris.
- Gaseous fluids such as natural gas and liquid propane (LP) gas are extremely EXPLOSIVE. Install the fuel supply system according to applicable fuel-gas codes. Before placing the home standby electric system into service, fuel system lines must be properly purged and leak tested according to applicable code. After installation, inspect the fuel system periodically for leaks. No leakage is permitted.

** STANDARDS INDEX**

In the absence of pertinent standards, codes, regulations and laws, the published information listed below may be used as installation guide for this equipment.

1. NFPA No. 37, STATIONARY COMBUSTION ENGINES AND GAS TURBINES, available from the National Fire Protection Association, 470 Atlantic Avenue, Boston, MA 02210.
2. NFPA No. 76A, ESSENTIAL ELECTRICAL SYSTEMS FOR HEALTH CARE FACILITIES, available same as Item 1.
3. NFPA No. 54, NATIONAL FUEL GAS CODE, available same as Item 1.
4. NFPA No. 58, AMERICAN NATIONAL STANDARD FOR STORAGE AND HANDLING OF LIQUEFIED PETROLEUM GAS, available same as Item 1.
5. NFPA No. 70, NFPA HANDBOOK OF NATIONAL ELECTRIC CODE, available same as Item 1.
6. Article X, NATIONAL BUILDING CODE, available from the American Insurance Association, 85 John Street, New York, N.Y. 10038.
7. AGRICULTURAL WIRING HANDBOOK, available from the Food and Energy Council, 909 University Avenue, Columbia, MO 65201.
8. ASAE EP-3634, INSTALLATION AND MAINTENANCE OF FARM STANDBY ELECTRICAL SYSTEMS, available from the American Society of Agricultural Engineers, 2950 Niles Road, St. Joseph, MI 49085.
9. NFPA No. 30, FLAMMABLE AND COMBUSTIBLE LIQUIDS CODE, available same as Item 1.

**⚠ DANGER ⚠**

⚠ Only qualified electricians or contractors should attempt such installations, which must comply strictly with applicable codes, standards and regulations.

### 1.1 UNPACKING/INSPECTION

After unpacking, carefully inspect the contents for damage.

- This standby generator set is ready for installation with a factory supplied and pre-mounted base pad and has a weather protective enclosure that is intended for **outdoor installation only**.
- This UL listed standby generator set is packaged with an automatic transfer switch with built in load center. The combination transfer switch and load center is pre-wired with a two foot and 30 foot conduit. Circuit breakers for emergency circuit connections are included (if equipped).
- This UL listed, 2-pole switch is rated at 100 AC amperes at 250 volts maximum. **This transfer switch is for indoor use only (if equipped)**.

**⚠ WARNING ⚠**

⚠ If this generator is used to power electrical load circuits normally powered by a utility power source, it is required by code to install a transfer switch. The transfer switch must effectively isolate the electrical system from the utility distribution system when the generator is operating (NEC 700, 701 & 702). Failure to isolate an electrical system by such means will result in damage to the generator and also may result in injury or death to utility power workers due to backfeed of electrical energy.

If any loss or damage is noted at time of delivery, have the person(s) making the delivery note all damage on the freight bill or affix their signature under the consignor's memo of loss or damage.

If a loss or damage is noted after delivery, separate the damaged materials and contact the carrier for claim procedures.

“Concealed damage” is understood to mean damage to the contents of a package that is not in evidence at the time of delivery, but is discovered later.

### 1.2 PROTECTION SYSTEMS

Unlike an automobile engine, the generator may have to run for long periods of time with no operator present to monitor engine conditions. For that reason, the engine is equipped with the following systems that protect it against potentially damaging conditions:

- |                            |                |
|----------------------------|----------------|
| 1. Low Oil Pressure Sensor | 4. Overspeed   |
| 2. High Temperature Sensor | 5. RPM Sensor  |
| 3. Overcrank               | 6. Low Battery |

There are LED readouts on the control panel to notify personnel that one of these faults has occurred. There is also a System Set LED that is lit when all of the conditions described in section "System Set LED" are true. (See the "Protection Systems" section for details.)

### 1.3 NEC REQUIREMENT FOR ARC FAULT CIRCUIT INTERRUPTION BREAKER FOR BEDROOMS

In 2001, the National Electric Code (NEC) introduced a requirement for new construction. This new requirement indicates the need for Arc Fault Circuit Interrupters to be used to protect the complete branch circuit that feeds a dwelling bedroom. The actual NEC requirement is indicated below.

#### ◆ 1.3.1 SECTION 210.12 ARC FAULT CIRCUIT INTERRUPTER PROTECTION

1. Definition: An arc fault circuit interrupter is a device intended to provide protection from the effects of arc faults by recognizing characteristics unique to arcing and by functioning to de-energize the circuit when an arc fault is detected.
2. Dwelling Unit Bedrooms: All branch circuits that supply 125 volt, single-phase, 15 and 20 ampere outlets installed in dwelling unit bedrooms shall be protected by an arc fault circuit interrupter listed to provide protection of the entire branch circuit.

Section 210.12 requires that AFCI protection be provided on branch circuits that supply outlets (receptacle, lighting, etc.) in dwelling bedrooms. The requirement is limited to 15 and 20 ampere, 125 volt circuits. There is no prohibition against providing AFCI protection on other circuits or in locations other than bedrooms. Because circuits are often shared between a bedroom and other areas such as closets and hallways, providing AFCI protection on the complete circuit would comply with 210.12.

If during the installation of the home standby system the decision is made to provide back up power to a bedroom branch circuit, then the circuit breaker in the transfer switch should be replaced with an Arc Fault Circuit Interrupter.

It is most important that breakers only be switched like for like. For instance, if replacing a 15A breaker, it MUST be replaced with a 15A AFCI breaker. Likewise, a 20A breaker MUST be replaced with a 20A AFCI.

These AFCI breakers are available at the nearest hardware store.

Siemens Item #	Description
Q115AF	15A Single Pole AFCI
Q120AF	20A Single Pole AFCI

## 1.4 THE GENERATOR

Figure 1.1 – 7kW, Single Cylinder GH-410 Engine

Figure 1.2 – 10kW, V-twin GT-530 Engine

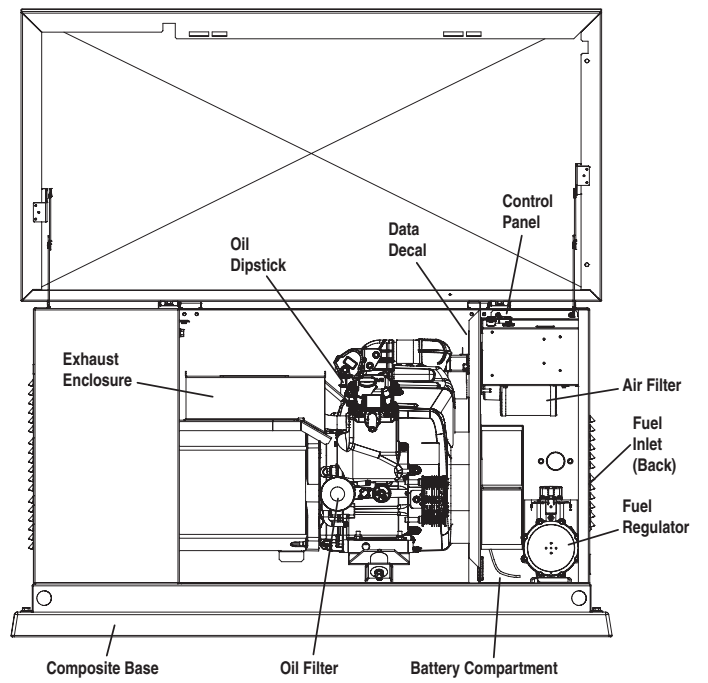
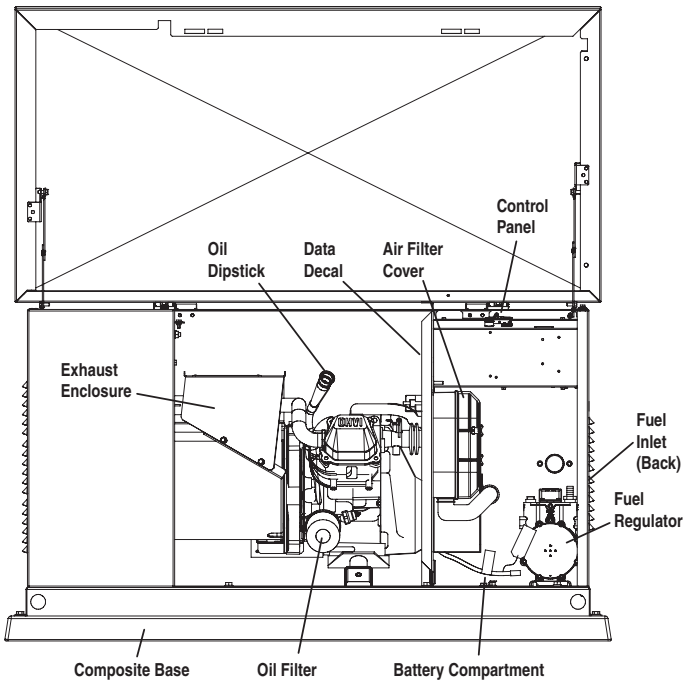
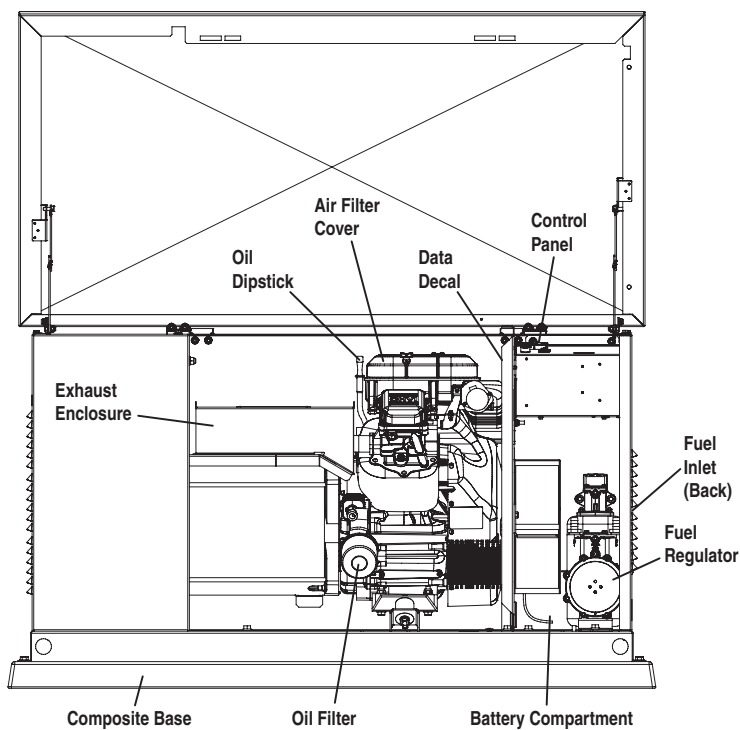
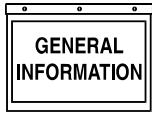

Figure 1.3 – 13kW and 16kW, V-twin GT-990 Engine





## Section 1 – General Information

### Air-cooled Generators

## 1.5 SPECIFICATIONS

### ◆ 1.5.1 GENERATOR

Model	05240 & 05280	05241 & 05281	05242 & 05282	05243 & 05244 05283 & 05284
Rated Max. Continuous Power Capacity (Watts*)	6,000 NG/7,000 LP	9,000 NG/10,000 LP	13,000 NG/13,000 LP	15,000 NG/16,000 LP
Rated Voltage	120/240	120/240	120/240	120/240
Rated Max. Continuous Load Current (Amps)				
120 Volts**	50.0 NG/58.3 LP	75.0 NG/83.3 LP	108.3 NG/108.3 LP	125 NG/133.3 LP
240 Volts	25.0 NG/29.2 LP	37.5 NG/41.7 LP	54.1 NG/54.1 LP	62.5 NG/66.6 LP
Main Line Circuit Breaker	30 Amp	45 Amp	55 Amp	65 Amp
Circuits***				
50A, 240V	-	-	-	1
40A, 240V	-	-	1	1
30A, 240V	1	1	1	-
20A, 240V	-	1	-	1
20A, 120V	1	3	3	5
15A, 120V	5	3	5	5
Phase	1	1	1	1
Number of Rotor Poles	2	2	2	2
Rated AC Frequency	60 Hz	60 Hz	60 Hz	60 Hz
Power Factor	1	1	1	1
Recommended Air Filter	Part # 0C8127	Part # 0E9581	Part # 0C8127	Part # 0C8127
Battery Requirement	Group 26 12 Volts and 350 Cold-cranking Amperes Minimum	Group 26 12 Volts and 525 Cold-cranking Amperes Minimum	Group 26 12 Volts and 525 Cold-cranking Amperes Minimum	Group 26 12 Volts and 525 Cold-cranking Amperes Minimum
Battery Warming Blanket	OF6148DSRV			
Weight (Unit Only)	336 Pounds	375 Pounds	425.5 Pounds	445 & 414 Pounds
Enclosure				Steel/Aluminum
Normal Operating Range	-20°F (-28.8°C) to 104°F (40°C)			

\* Maximum wattage and current are subject to and limited by such factors as fuel Btu content, ambient temperature, altitude, engine power and condition, etc. Maximum power decreases about 3.5 percent for each 1,000 feet above sea level; and also will decrease about 1 percent for each 6° C (10° F) above 16° C (60° F) ambient temperature.

\*\* Load current values shown for 120 volts are maximum TOTAL values for two separate circuits. The maximum current in each circuit must not exceed the value stated for 240 volts.

\*\*\* Circuits to be moved must be protected by same size breaker. For example, a 15 amp circuit in main panel must be a 15 amp circuit in transfer switch.

### ◆ 1.5.2 ENGINE

Model	05240 & 05280	05241 & 05281	05242 & 05282	05243 & 05244 05283 & 05284
Type of Engine	GH-410	GT-530	GT-990	GT-990
Number of Cylinders	1	2	2	2
Rated Horsepower	14.5 @ 3,600 rpm	18 @ 3,600 rpm	30 @ 3,600 rpm	30 @ 3,600 rpm
Displacement	410cc	530cc	992cc	992cc
Cylinder Block	Aluminum w/Cast Iron Sleeve	Aluminum w/Cast Iron Sleeve	Aluminum w/Cast Iron Sleeve	Aluminum w/Cast Iron Sleeve
Valve Arrangement	Overhead Valves	Overhead Valves	Overhead Valves	Overhead Valves
Ignition System	Solid-state w/Magneto	Solid-state w/Magneto	Solid-state w/Magneto	Solid-state w/Magneto
Recommended Spark Plug	RC14YC	BPR6HS	RC12YC	RC12YC
Spark Plug Gap	0.76 mm (0.030 inch)	0.76 mm (0.030 inch)	1.02 mm (0.040 inch)	1.02 mm (0.040 inch)
Compression Ratio	8.6:1	9.5:1	9.5:1	9.5:1
Starter	12 Vdc	12 Vdc	12 Vdc	12 Vdc
Oil Capacity Including Filter	Approx. 1.5 Qts	Approx. 1.7 Qts	Approx. 1.7 Qts	Approx. 1.7 Qts
Recommended Oil Filter	Part # 070185B	Part # 070185B	Part # 070185B	Part # 070185B
Recommended Air Filter	Part # 0C8127	Part # 0E9581	Part # 0C8127	Part # 0C8127
Operating RPM	3,600	3,600	3,600	3,600



## 1.6 SYSTEM SET LED

The “System Set” LED is lit when all of the following conditions are true:

1. The AUTO/OFF/MANUAL switch is set to the AUTO position.
2. The utility voltage being supplied to the unit is being sensed by the PCB. If the utility sense voltage is not connected to the unit or if it is below approximately 150-160 volts AC, then the system set light will flash rapidly. This indicates that if the AUTO/OFF/ MANUAL switch is placed in the Auto position, the generator will start.
3. No alarms are present, for example, low oil pressure, high temperature, etc.

## 1.7 FUEL REQUIREMENTS AND RECOMMENDATIONS

**With LP gas, use only the vapor withdrawal system.** This type of system uses the vapors formed above the liquid fuel in the storage tank.

The engine has been fitted with a fuel carburetion system that meets the specifications of the 1997 California Air Resources Board for tamper-proof dual fuel systems. The unit will run on natural gas or LP gas, but it has been factory set to run on natural gas. Should the primary fuel need to be changed to LP gas, the fuel system needs to be reconfigured. See the Reconfiguring the Fuel System section for instructions on reconfiguration of the fuel system.

Recommended fuels should have a Btu content of at least 1,000 Btus per cubic foot for natural gas; or at least 2,520 Btus per cubic foot for LP gas. Ask the fuel supplier for the Btu content of the fuel.

Required fuel pressure for **natural gas is 5 inches to 7 inches water column (0.18 to 0.25 psi); and for liquid propane, 10 inches to 12 inches of water column (0.36 to 0.43 psi).**

**NOTE:**

**All pipe sizing, construction and layout must comply with NFPA 54 for natural gas applications and NFPA 58 for liquid propane applications. Once the generator is installed, verify that the fuel pressure NEVER drops below four (4) inches water column for natural gas or 10 inches water column for liquid propane.**

Prior to installation of the generator, the installer should consult local fuel suppliers or the fire marshall to check codes and regulations for proper installation. Local codes will mandate correct routing of gaseous fuel line piping around gardens, shrubs and other landscaping to prevent any damage.

Special considerations should be given when installing the unit where local conditions include flooding, tornados, hurricanes, earthquakes and unstable ground for the flexibility and strength of piping and their connections.

Use an approved pipe sealant or joint compound on all threaded fitting.

All installed gaseous fuel piping must be purged and leak tested prior to initial start-up in accordance with local codes, standards and regulations.

## 1.8 FUEL CONSUMPTION

Unit	Nat. Gas (*)		LP Vapor (**)	
	1/2 Load	Full Load	1/2 Load	Full Load
6/7 kW	66	119	0.82/30	1.47/54
9/10 kW	102	156	1.25/46	1.93/70
13/13 kW	156	220	1.55/57	2.18/80
15/16 kW	173	245	1.59/59	2.51/92

\*Natural gas is in cubic feet per hour.

\*\*LP is in gallons per hour/cubic feet per hour.

\*\*\* Values given are approximate.

### ◆ 1.8.1 BTU FLOW REQUIREMENTS - NATURAL GAS

BTU flow required for each unit based on 1000 BTU per cubic foot.

- 6kW — 119,000 BTU/Hour
- 9kW — 156,000 BTU/Hour
- 13kW — 220,000 BTU/Hour
- 15kW — 245,000 BTU/Hour



**▲ Gaseous fuels such as natural gas and liquid propane (LP) gas are highly explosive. Even the slightest spark can ignite such fuels and cause an explosion. No leakage of fuel is permitted. Natural gas, which is lighter than air, tends to collect in high areas. LP gas is heavier than air and tends to settle in low areas.**

**NOTE:**

**A minimum of one approved manual shut-off valve must be installed in the gaseous fuel supply line. The valve must be easily accessible. Local codes determine the proper location.**

## 1.9 RECONFIGURING THE FUEL SYSTEM

### ◆ 1.9.1 7 KW, 410CC ENGINE

To reconfigure the fuel system from NG to LP, follow these steps (Figure 1.4):

**NOTE:**

**The primary regulator for the propane supply is NOT INCLUDED with the generator. A fuel pressure of 10 to 12 inches of water column (0.36 to 0.43 psi) to the fuel inlet of the generator MUST BE SUPPLIED.**

1. Turn off the main gas supply (if connected).
2. Open the roof and remove the door.
3. Remove the battery (if installed).
4. Disconnect wire #0 and wire #14 from the gas solenoid on top of the demand regulator.
5. Remove the carburetor fuel hose from the outlet port of the demand regulator.
6. Remove the demand regulator by removing the fastener that retains the regulator mounting bracket.
7. Remove the square headed steel pipe plug from outlet port #1 and the brass hose barb fitting from outlet port #2.
8. Refit the brass hose barb fitting to outlet port #1 and the square headed steel pipe plug to outlet port #2.

**Figure 1.4 – Demand Regulator**

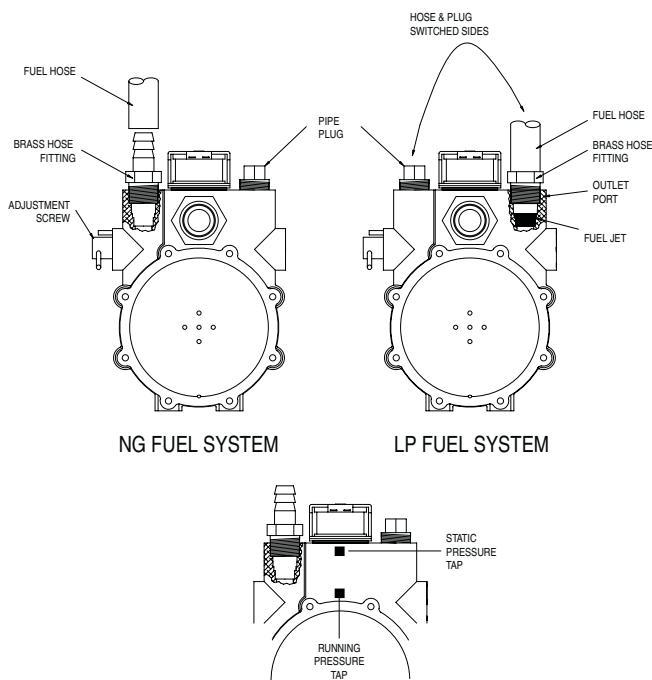

**NOTE:**

**Use an approved pipe sealant or joint compound on all threaded fittings to reduce the possibility of leakage.**

9. Reverse procedure steps 1-6 to reinstall demand regulator.
10. Take the plastic plug supplied in the poly-bag with the generator and press it into the 3/4" hole on the bottom of the air cleaner base (Figure 4.6).
11. Reverse the procedure to convert back to natural gas.
12. Check for gas leakage at the pipe plug, hose connection and fittings.

### ◆ 1.9.2 10, 13 AND 16KW, V-TWIN ENGINES

To reconfigure the fuel system from NG to LP, follow these steps:

**NOTE:**

**The primary regulator for the propane supply is NOT INCLUDED with the generator. A fuel pressure of 10 to 12 inches of water column (0.36 to 0.43 psi) to the fuel inlet of the generator MUST BE SUPPLIED.**

1. Open the roof.
2. **For 10kW units:** Loosen clamp and slide back the air inlet hose.
  - Slide fuel selector on carburetor out towards the back of the enclosure (Figures 1.5 and 1.6).
  - Return the inlet hose and tighten clamp securely.
- For 13 and 16kW units:** remove the air cleaner cover.
  - Slide the selector lever out towards the back of the enclosure (Figures 1.7 and 1.8).
  - Return the air cleaner cover and tighten the two thumb screws.
3. Close the roof.
4. Reverse the procedure to convert back to natural gas.

Figure 1.5 - 10kW, GT-530 (Inlet Hose Slid Back)

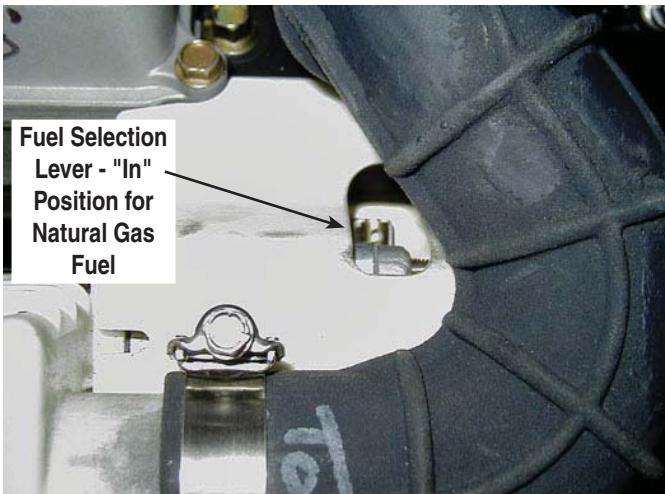

Figure 1.6 - 10kW, GT-530 (Inlet Hose Slid Back)

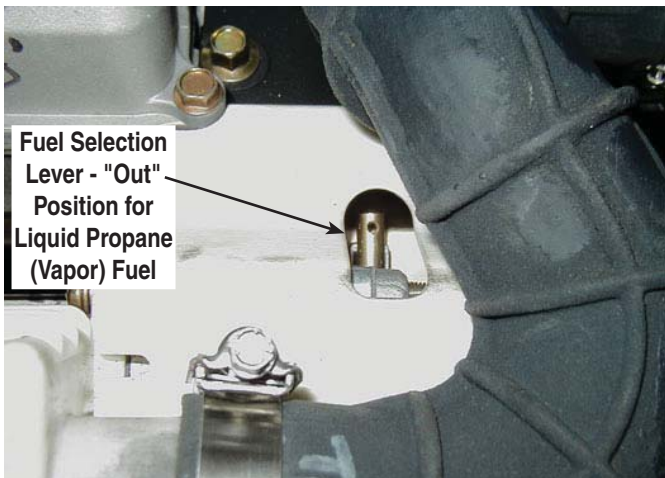

Figure 1.7 - 13/16kW, GT-990 (Airbox Cover Removed)

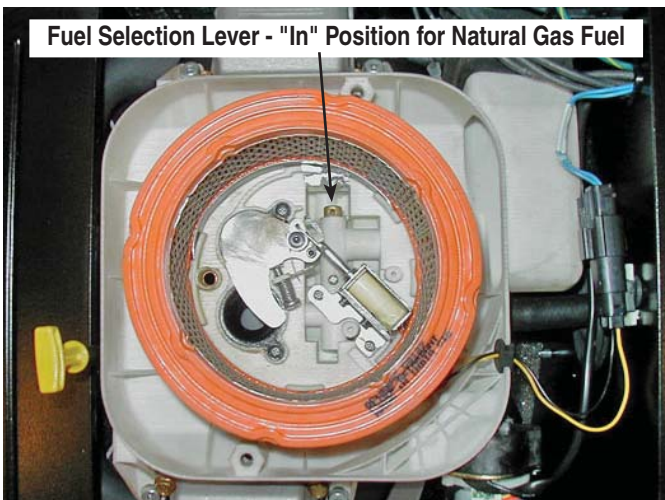
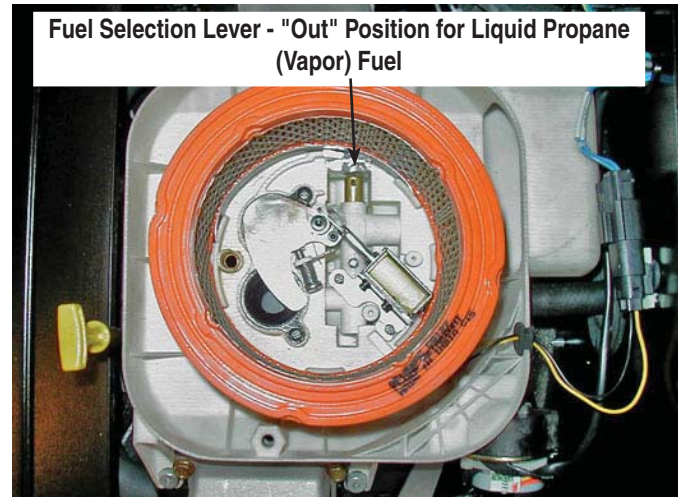

Figure 1.8 - 13/16kW, GT-990 (Airbox Cover Removed)



## 1.10 LOCATION

### ◆ 1.10.1 GENERATOR

Install the generator set, in its protective enclosure, **outdoors**, where adequate cooling and ventilating air is always available (Figure 1.9). Consider these factors:

- The installation of the generator **must comply strictly with NFPA 37, NFPA 54, NFPA 58, and NFPA 70 standards.**
- Install the unit where air inlet and outlet openings will not become obstructed by leaves, grass, snow, etc.. If prevailing winds will cause blowing or drifting, consider using a windbreak to protect the unit.
- Install the generator on high ground where water levels will not rise and endanger it.
- Allow sufficient room on all sides of the generator for maintenance and servicing. This unit must be installed in accordance with current applicable NFPA 37 and NFPA 70 standards; as well as any other federal, state and local codes for minimum distances from other structures. **DO NOT** install under wooden decks or structures.
- Install the unit where rain gutter down spouts, roof fun-off, landscape irrigation, water sprinklers or sump pump discharge does not flood the unit or spray the enclosure, including any air inlet or outlet openings.
- Install the unit where services will not be affected or obstructed, including concealed, underground or covered services such as electrical, fuel, phone, air conditioning or irrigation.
- Where strong prevailing winds blow from one direction, face the generator air inlet openings to the prevailing winds.

- Install the generator as close as possible to the fuel supply, to reduce the length of piping.
- Install the generator as close as possible to the transfer switch. **REMEMBER THAT LAWS OR CODES MAY REGULATE THE DISTANCE AND LOCATION.**
- The genset must be installed on a level surface. The base frame must be level within two (2) inches all around.
- The generator is typically placed on pea gravel or crushed stone. Check local codes if a concrete slab is required. If a concrete base slab is required, all federal, state and local codes should be followed. Special attention should be given to the concrete base slab which should exceed the length and width of the generator by a minimum of six (6) inches (0.152 meters) on all sides.

Figure 1.9 – Generator Clearances

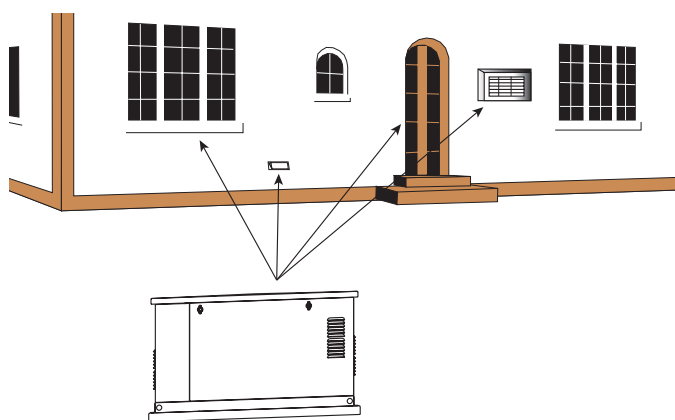

**WARNING**

**⚠** The engine exhaust fumes contain carbon monoxide, which can be **DEADLY**. This dangerous gas, if breathed in sufficient concentrations, can cause unconsciousness or even death. This exhaust system must be installed properly, in strict compliance with applicable codes and standards. Following installation, do nothing that might render the system unsafe or in noncompliance with such codes and standards.

- Operate the generator outdoors **ONLY**.
- Keep exhaust gases from entering a confined area through windows, doors, ventilation or other openings (Figure 1.9).

## ◆ 1.10.2 TRANSFER SWITCH

### 1.10.2.1 7, 10, 13, and 16 kW Units (if equipped)

The transfer switch shipped with this generator is enclosed in a NEMA 1 enclosure. **This type of enclosure is intended for indoor use only.** Follow these rules:

- Install the transfer switch indoors on a firm, sturdy supporting structure.
- To prevent switch distortion, level the switch if necessary. This can be done by placing washers between the switch enclosure and mounting surface.
- Never install the switch where water or any corrosive substance might drip onto the enclosure.
- Protect the switch at all times against excessive moisture, dust, dirt, lint, construction grit and corrosive vapors.

**WARNING**

**⚠** If the **AUTO/OFF/MANUAL** switch is not set to its **OFF** position, the generator can crank and start as soon as the battery cables are connected. If the utility power supply is not turned off, sparking can occur at the battery posts and cause an explosion.

## 1.11 BATTERY REQUIREMENTS

See the Specifications section for correct battery size and rating.

## 1.12 BATTERY INSTALLATION

Fill the battery with the proper electrolyte fluid if necessary and have the battery fully charged before installing it.

Before installing and connecting the battery, complete the following steps:

1. Set the generator's **AUTO/OFF/MANUAL** switch to **OFF**.
2. Turn off utility power supply to the transfer switch.
3. Remove the 15A fuse from the generator control panel.

Battery cables were factory connected at the generator (Figure 1.10). Connect cables to battery posts as follows:

4. Connect the red battery cable (from starter contactor) to the battery post indicated by a positive, POS or (+).
5. Connect the black battery cable (from frame ground) to the battery post indicated by a negative, NEG or (—).

**NOTE:**

**Dielectric grease should be used on battery posts to aid in the prevention of corrosion.**

**NOTE:**

**Damage will result if battery connections are made in reverse.**

Figure 1.10 – Battery Cable Connections

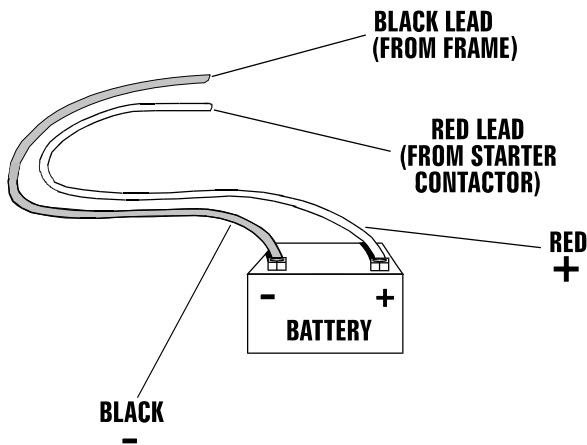

**NOTE:**

In areas where temperatures regularly fall below 10° F (-12° C) it is recommended that a pad type battery heater be installed to aid in cold climate starting (see Specifications).

**NOTE:**

The generator is equipped with a battery trickle charger that is active when the unit is set up for automatic operation. With the battery installed and utility power source voltage available to the transfer switch, the battery receives a trickle charge while the engine is not running, to prevent self-discharge. The trickle charger is designed to help extend the life of the battery by maintaining the battery when the unit is not running. The trickle charge feature cannot be used to recharge a discharged battery.

### 1.13 THE BATTERY

**⚠ DANGER ⚠**

- ⚠ Do not dispose of the battery in a fire. The battery is capable of exploding.
- ⚠ A battery presents a risk of electrical shock and high short circuit current. The following precautions are to be observed when working on batteries:
  - Remove the 15A fuse from the generator control panel.
  - Remove watches, rings or other metal objects;
  - Use tools with insulated handles;
  - Wear rubber gloves and boots;
  - Do not lay tools or metal parts on top of the battery; and
  - Disconnect charging source prior to connecting or disconnecting battery terminals.

**⚠ WARNING ⚠**

- ⚠ Do not open or mutilate the battery. Released electrolyte has been known to be harmful to the skin and eyes, and to be toxic.
- ⚠ The electrolyte is a dilute sulfuric acid that is harmful to the skin and eyes. It is electrically conductive and corrosive.

The following procedures are to be observed:

- Wear full eye protection and protective clothing;
  - Where electrolyte contacts the skin, wash it off immediately with water;
  - Where electrolyte contacts the eyes, flush thoroughly and immediately with water and seek medical attention; and
  - Spilled electrolyte is to be washed down with an acid neutralizing agent. A common practice is to use a solution of 1 pound (500 grams) bicarbonate of soda to 1 gallon (4 liters) of water. The bicarbonate of soda solution is to be added until the evidence of reaction (foaming) has ceased. The resulting liquid is to be flushed with water and the area dried.
- ⚠ Lead-acid batteries present a risk of fire because they generate hydrogen gas. The following procedures are to be followed:
    - DO NOT SMOKE when near the battery;
    - DO NOT cause flame or spark in battery area; and
    - Discharge static electricity from body before touching the battery by first touching a grounded metal surface.
  - ⚠ Be sure the AUTO/OFF/MANUAL switch is set to the OFF position before connecting the battery cables. If the switch is set to AUTO or MANUAL, the generator can crank and start as soon as the battery cables are connected.
  - ⚠ Be sure the utility power supply is turned off and the 15A fuse is removed from the generator control panel, or sparking may occur at the battery posts as the cables are attached and cause an explosion.

Servicing of the battery is to be performed or supervised by personnel knowledgeable of batteries and the required precautions. Keep unauthorized personnel away from batteries.

See the Specifications section for the correct size and rating when replacing the battery. When using a maintenance-free battery, it is not necessary to check the specific gravity or electrolyte level. Have these procedures performed at the intervals specified in the "Service Schedule." A negative ground system is used. Battery connections are shown on the wiring diagrams. Make sure the battery is correctly connected and terminals are tight. Observe battery polarity when connecting the battery to the generator set.

## 2.1 BEFORE INITIAL START-UP

### NOTE:

**These units have been run and tested at the factory prior to being shipped and do not require any type of break-in.**

Before starting, complete the following:

1. Set the generator's main circuit breaker to its OFF (or OPEN) position.
2. Set the generator's AUTO/OFF/MANUAL switch to the OFF position.
3. Turn OFF all breakers on the load center of the transfer box (T1 and T2).
4. Turn OFF all loads connected to the transfer switch terminals T1 and T2.
5. Check the engine crankcase oil level and, if necessary, fill to the dipstick FULL mark with the recommended oil. Do not fill above the FULL mark.
6. Check the fuel supply. Gaseous fuel lines must have been properly purged and leak tested in accordance with applicable fuel-gas codes. All fuel shutoff valves in the fuel supply lines must be open.



 **Never operate the engine with the oil level below the "Add" mark on the dipstick. Doing this could damage the engine.**

## 2.2 CHECK TRANSFER SWITCH OPERATION

Refer to the "Manual Transfer Operation" section, of the owner's manual for procedures.



 **Do not attempt manual transfer switch operation until all power voltage supplies to the transfer switch have been positively turned off. Failure to turn off all power voltage supplies will result in extremely hazardous and possibly fatal electrical shock.**

## 2.3 ELECTRICAL CHECKS

Complete electrical checks as follows:

1. Set the generator's main circuit breaker to its OFF (or OPEN) position.
2. Set the generator's AUTO/OFF/MANUAL switch to the OFF position.
3. Turn OFF all breakers on the load center of the transfer box (T1 and T2).
4. Turn on the utility power supply to the transfer switch using the means provided (such as a utility main line circuit breaker).



 **The transfer switch is now electrically "hot." Contact with "hot" parts will result in extremely hazardous and possibly fatal electrical shock. Proceed with caution.**

5. Use an accurate AC voltmeter to check utility power source voltage across transfer switch terminals N1 and N2. Nominal line-to-line voltage should be 240 volts AC.
6. Check utility power source voltage across terminals N1 and the transfer switch neutral lug; then across terminal N2 and neutral. Nominal line-to-neutral voltage should be 120 volts AC.
7. When certain that utility supply voltage is compatible with transfer switch and load circuit ratings, turn OFF the utility power supply to the transfer switch.
8. On the generator panel, set the AUTO/OFF/MANUAL switch to MANUAL. The engine should crank and start.
9. Let the engine warm up for about five minutes to allow internal temperatures to stabilize. Then, set the generator's main circuit breaker to its ON (or CLOSED) position.



 **Proceed with caution! Generator power voltage is now supplied to the transfer switch. Contact with live transfer switch parts will result in dangerous and possibly fatal electrical shock.**

10. Connect an accurate AC voltmeter and a frequency meter across transfer switch terminal lugs E1 and E2. 7kW voltage should be 242-252 volts at a frequency of 61-63 Hertz. 10, 13, and 16kW voltage should be 247-249 volts at a frequency of 57.5-59.5 Hertz.
11. Connect the AC voltmeter test leads across terminal lugs E1 and neutral; then across E2 and neutral. In both cases, voltage reading should be 121-126 volts AC (7kW), and 125-126 volts AC (10, 13 and 16kW).
12. Set the generator's main circuit breaker to its OFF (or OPEN) position. Let the engine run at no-load for a few minutes to stabilize internal engine generator temperatures.
13. Set the generator's AUTO/OFF/MANUAL switch to OFF. The engine should shut down.

### NOTE:

**It is important not to proceed until certain that generator AC voltage and frequency are correct and within the stated limits. Generally, if both AC frequency and voltage are high or low, the engine governor requires adjustment\* (\*GH410 only). If frequency is correct, but voltage is high or low, the generator's voltage regulator requires adjustment.**

## 2.4 GENERATOR TESTS UNDER LOAD

To test the generator set with electrical loads applied, proceed as follows:

1. Set generator's main circuit breaker to its OFF (or OPEN) position.
2. Turn OFF all breakers on the load center of the transfer box (T1 and T2).
3. Set the generator's AUTO/OFF/MANUAL switch to OFF.
4. Turn OFF the utility power supply to the transfer switch, using the means provided (such as a utility main line circuit breaker).



### WARNING

-  **Do not attempt manual transfer switch operation until all power voltage supplies to the transfer switch have been positively turned off. Failure to turn off all power voltage supplies will result in extremely hazardous and possibly fatal electrical shock.**
5. Manually set the transfer switch to the STANDBY position, i.e., load terminals connected to the generator's E1/E2 terminals. The transfer switch operating lever should be down.
  6. Set the generator's AUTO/OFF/MANUAL switch to MANUAL. The engine should crank and start immediately.
  7. Let the engine stabilize and warm up for a few minutes.
  8. Set the generator's main circuit breaker to its ON (or closed) position. Loads are now powered by the standby generator.
  9. Turn ON the load center of the transfer switch (T1 and T2).
  10. Connect an accurate AC voltmeter and a frequency meter across terminal lugs E1 and E2.
    - 7kW voltage should be greater than 230 volts and frequency should be greater than 58 Hz.
    - 10, 13 & 16kW voltage should be greater than 240 volts and frequency should be greater than 60 Hz.
  11. Let the generator run at full rated load for 20-30 minutes. Listen for unusual noises, vibration or other indications of abnormal operation. Check for oil leaks, evidence of overheating, etc.
  12. When testing under load is complete, turn OFF electrical loads.
  13. Set the generator's main circuit breaker to its OFF (or OPEN) position.
  14. Let the engine run at no-load for a few minutes.
  15. Set the AUTO/OFF/MANUAL switch to OFF. The engine should shut down.

## 2.5 CHECKING AUTOMATIC OPERATION

To check the system for proper automatic operation, proceed as follows:

1. Set generator's main circuit breaker to its OFF (or OPEN) position.
2. Check that the AUTO/OFF/MANUAL switch is set to OFF.
3. Turn OFF the utility power supply to the transfer switch, using means provided (such as a utility main line circuit breaker).
4. Manually set the transfer switch to the UTILITY position, i.e., load terminals connected to the utility power source side.
5. Turn ON the utility power supply to the transfer switch, using the means provided (such as a utility main line circuit breaker).
6. Set the generator's main circuit breaker to its ON (or CLOSED) position.
7. Set the AUTO/OFF/MANUAL switch to AUTO. The system is now ready for automatic operation.
8. Turn OFF the utility power supply to the transfer switch.

With the AUTO/OFF/MANUAL switch at AUTO, the engine should crank and start when the utility source power is turned OFF after a 10 second delay. After starting, the transfer switch should connect load circuits to the standby side after a 15 second delay. Let the system go through its entire automatic sequence of operation.

With the generator running and loads powered by generator AC output, turn ON the utility power supply to the transfer switch. The following should occur:

- After about 15 seconds, the switch should transfer loads back to the utility power source.
- About one minute after retransfer, the engine should shut down.

## 2.6 ADJUSTING THE FUEL REGULATOR - 7KW (NATURAL GAS ONLY)

### NOTE:

**All V-twin engine units DO NOT require a fuel regulator adjustment due to the fuel system design.**

Although the generator has been factory set to provide maximum power, it may be necessary in some areas to adjust this setting. If experiencing engine problems at high or full load conditions, follow these steps. It will require a frequency meter to perform this procedure.

1. Turn off utility power to the main distribution panel in the house. This can be done by switching the service main breaker to the off or open position.
2. Allow the generator to start. Before loading the generator, confirm that the No Load Frequency, with the roof open and door off, is set to 63-63.5 Hz. Transfer load to emergency circuits.
3. Turn on appliances, lights, pumps, etc., that are on the emergency circuits in an attempt to fully load the generator. Be cautious not to overload the generator. Use the following chart as a guide:

Unit	120 Volts	240 Volts
7 kW	50.0 amps	25.0 amps

4. When 3/4 load has been achieved. Connect a frequency meter to the output lugs of the generator's main line circuit breaker.
5. The fuel regulator is fitted with one adjustment screw. While watching the frequency meter, slowly turn the adjustment screw clockwise or counterclockwise until the highest frequency is read on the meter. Only limited adjustment is available because of the set pin. Under no circumstances should any of the pins be removed (Figure 2.1).

Figure 2.1 — 7kW Fuel Regulator

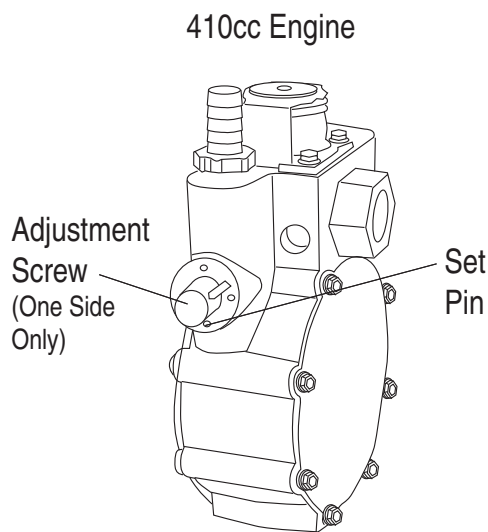

6. When the highest frequency is reached maximum power has been set. From this point turn the adjustment screw 1/4 turn counterclockwise. The regulator is now set.
7. Turn utility power to the main distribution panel back on. This can be done by switching the service main breaker to the on or closed position. Allow the generator to shut down.

**WARNING**

⚠ Do not make any unnecessary adjustments. Factory settings are correct for most applications. However, when making adjustments, be careful to avoid overspeeding the engine.

If this procedure or the test equipment is not available, locate the nearest Dealer and they can perform the adjustments.

**NOTE:**

A service fee may be charged for this adjustment.

## 2.7 ENGINE GOVERNOR ADJUSTMENT

If both AC frequency and voltage are correspondingly high or low, adjust the engine governor as follows:

### ◆ 2.7.1 7 KW UNITS

**WARNING**

⚠ The engine must be OFF to perform steps 1 and 2.

1. Loosen the governor clamp bolt (Figures 2.2).
2. Hold the governor lever at its wide open throttle position (clockwise), and rotate the governor shaft clockwise as far as it will go. Then, tighten the governor lever clamp bolt to 70 inch-pounds (8 N-m).
3. Start the generator; let it stabilize and warm up at no-load.

Figure 2.2 — Engine Governor Adjustment Single Cylinder Engines

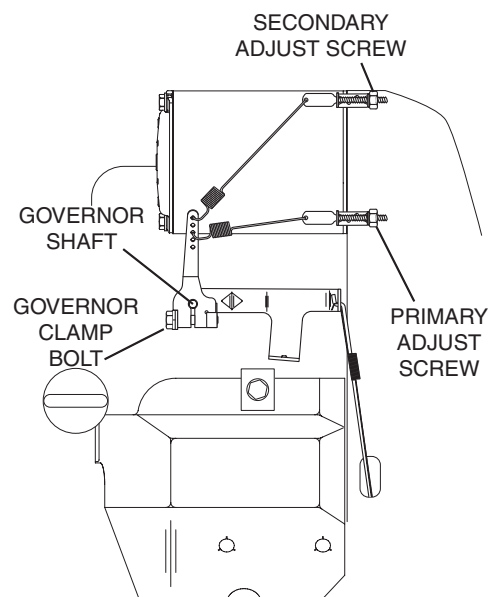



4. Connect a frequency meter across the generators AC output leads.
5. Turn the primary adjust screw to obtain a frequency reading of 61.5 Hertz. Turn the secondary adjust screw to obtain a frequency of 62.5 Hz.
6. When frequency is correct at no load, check the AC voltage reading. If voltage is incorrect, the voltage regulator may require adjustment (See the Voltage Regulator Adjustment section).

### ◆ 2.7.2 13 KW AND 16 KW UNITS

**NOTE:**

All V-twin units **DO NOT** require an engine governor adjustment due to their design.

### ◆ 2.7.3 ADDITIONAL CORROSION PROTECTION

Periodically spray all engine linkage parts and brackets with corrosion inhibiting spray such as WD-40 or a comparable product.

## 2.8 VOLTAGE REGULATOR ADJUSTMENT

### ◆ 2.8.1 7KW UNITS

With the frequency between 62-63 Hertz at no-load, slowly turn the slotted potentiometer (Figure 2.3) until line voltage reads 248-252 volts.

### ◆ 2.8.2 10, 13, AND 16KW UNITS

With the frequency between 58-59 Hertz at no-load, slowly turn the slotted potentiometer (Figure 2.3) until line voltage reads 247-249 volts.

Figure 2.3 – Voltage Adjustment Potentiometer

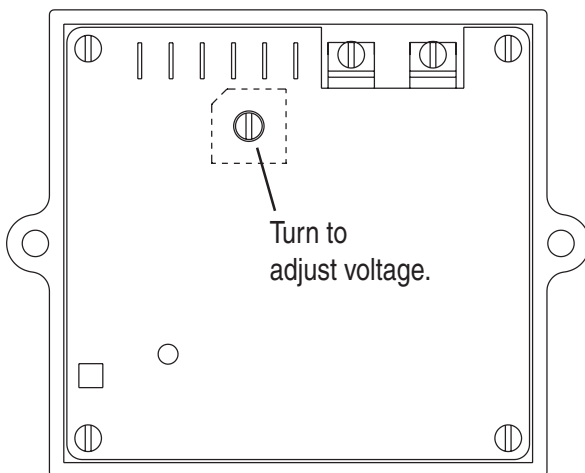

**NOTE:**

The access panel on top of the control panel must be removed to adjust the voltage regulator.

**NOTE:**

The voltage regulator is housed above the generator's control panel. The regulator maintains a voltage in direct proportion to frequency at a 2-to-1 ratio. For example, at 62 Hertz, line-to-neutral voltage will be 124 volts.

## 3.1 USING THE AUTO/OFF/MANUAL SWITCH (FIGURE 3.1)

### ◆ 3.1.1 "AUTO" POSITION

Selecting this switch position activates fully automatic system operation. It also allows the unit to automatically start and exercise the engine every seven days with the setting of the exercise timer (see the Setting the Exercise Timer section).

### ◆ 3.1.2 "OFF" POSITION

This switch position shuts down the engine. This position also prevents automatic operation.

Figure 3.1 – Generator Control Panel

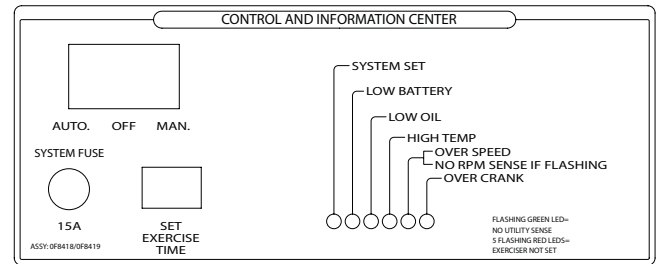

### ◆ 3.1.3 "MANUAL" POSITION

Set the switch to MANUAL to crank and start the engine. Transfer to standby power will not occur unless there is a utility failure.

**WARNING**

With the switch set to AUTO, the engine may crank and start at any time without warning. Such automatic starting normally occurs when utility power source voltage drops below a preset level or during the normal exercise cycle. To prevent possible injury that might be caused by such sudden starts, always set the switch to OFF and remove the fuses before working on or around the generator or transfer switch. Then, place a "DO NOT OPERATE" tag on the generator panel and on the transfer switch.

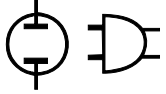

### ◆ 3.1.4 CHOKE OPERATION

1. 990 engines have an electric choke in the air box that is automatically controlled by the electronic control board.
2. 530 engines have an electric choke on the divider panel air inlet hose that is automatically controlled by the electronic control board.
3. 410 engines do not have a choke.

## 3.2 AUTOMATIC TRANSFER OPERATION

To select automatic operation, do the following:

1. Make sure the transfer switch main contacts are set to their UTILITY position, i.e., loads connected to the utility power source (Figure 3.2).
2. Be sure that normal UTILITY power source voltage is available to transfer switch terminal lugs N1 and N2 (Refer to the Electrical Data section).
3. Set the generator's AUTO/OFF/MANUAL switch to AUTO.
4. Set the generator's main circuit breaker to its ON (or CLOSED) position.

With the preceding steps complete, the generator will start automatically when utility source voltage drops below a preset level. After the unit starts, loads are transferred to the standby power source. Refer to the Sequence of Automatic Operation section.

## 3.3 SEQUENCE OF AUTOMATIC OPERATION

The generator's control panel houses a control logic circuit board. This board constantly monitors utility power source voltage. Should that voltage drop below a preset level, circuit board action will signal the engine to crank and start. After the engine starts, the circuit board signals the transfer switch to activate and connect load circuits to the standby power supply (load terminal lugs T1/T2 connect to terminal lugs E1/E2). Refer to the Electrical Data section.

The generator must run at 50 Hz or greater for the transfer output to be activated. Once activated, it will remain active even if the frequency dips below 50 Hz.

Upon restoration of utility source voltage above a preset level, generator circuit board action signals the transfer switch to transfer loads back to that power supply. After retransfer, the engine is signalled to shut down.

The actual sequence of operation is controlled by sensors and timers on a control logic circuit board, as follows:

- A. Utility Voltage Dropout Sensor
  - This sensor monitors utility source voltage.
  - If utility source voltage drops below about 65 percent of the nominal supply voltage, the sensor energizes a 10 second timer.
  - Once the timer has expired, the engine will crank and start if utility is still low.
- B. Engine Warm-up Time Delay
  - This mechanism lets the engine warm up for about five (5) seconds before the load is transferred to the standby source.
- C. Standby Voltage Sensor
  - This sensor monitors generator AC output voltage. When the voltage has reached 50 percent of the nominal rated voltage, transfer to standby can occur.
- D. Utility Voltage Pickup Sensor
  - This sensor monitors utility power supply voltage. When that voltage is restored above 75 percent of the nominal source voltage, a retransfer time delay starts timing.
- E. Retransfer Time Delay
  - This timer runs for about 15 seconds.
  - At end of a 15-second delay, circuit board action de-energizes transfer relay in the transfer switch if utility is still present.
  - Retransfer to utility power source then occurs.
- F. Engine Cool-down Timer
  - When the load is transferred back to utility power source, the engine cool-down timer starts timing.
  - The timer will run for about one minute, and the generator will then shut down.

## 3.4 MANUAL TRANSFER OPERATION

### ◆ 3.4.1 TRANSFER TO GENERATOR POWER SOURCE

To start the generator and activate the transfer switch manually, proceed as follows:

1. Set the generator's AUTO/OFF/MANUAL switch to OFF.
2. Set the generator's main circuit breaker to its OFF (or OPEN) position.
3. Turn OFF the utility power supply to the transfer switch using the means provided (such as a utility main line circuit breaker).



- ⚠ Do not attempt to activate the transfer switch manually until all power voltage supplies to the switch have been positively turned off. Failure to turn off all power voltage supplies may result in extremely hazardous and possibly fatal electrical shock.

4. Use the manual transfer handle inside the transfer switch to move the main contacts to their STANDBY position, i.e., loads connected to the standby power source (Figure 3.2).
5. To crank and start the engine, set the AUTO/OFF/MANUAL switch to MANUAL.
6. Let the engine stabilize and warm up for a few minutes.
7. Set the generator's main circuit breaker to its ON (or CLOSED) position. The standby power source now powers the loads.

Figure 3.2 – Manual Transfer Switch Operation

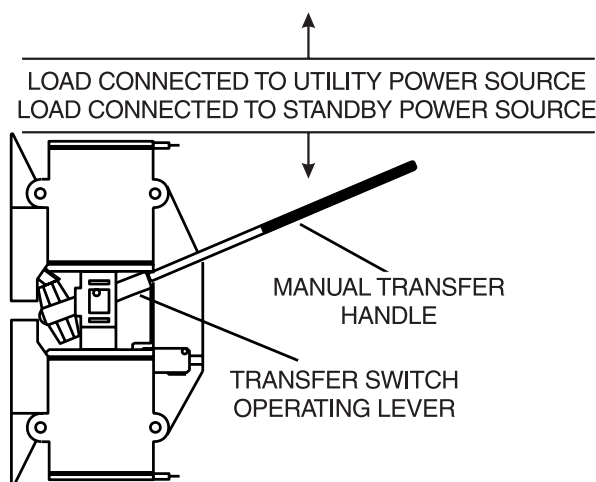

5. Use the manual transfer handle inside the transfer switch to move the main contacts back to their UTILITY position, i.e., loads connected to the utility power source (Figure 3.2).
6. Turn ON the utility power supply to the transfer switch using the means provided.
7. Set the system to automatic operation as outlined in Automatic Transfer Operation section.

### 3.5 SETTING THE EXERCISE TIMER

This generator is equipped with an exercise timer. Once it is set, the generator will start and exercise once every seven days, on the day of the week and at the time of day the following sequence is completed. During this exercise period, the unit runs for approximately 12 minutes and then shuts down. Transfer of loads to the generator output does not occur during the exercise cycle unless utility power is lost.

A switch on the control panel (see Figure 3.1) permits selection of the day and time for the system to exercise. At the chosen time, perform the following sequence to select the desired day and time of day the system will exercise. Remember seasonal time changes affect the exercise time settings.

1. Verify that the AUTO/OFF/MANUAL switch is set to AUTO.
2. Press and hold the "Set Exercise Time" switch for several seconds, then release. All the red LED's will flash for approximately 10 seconds and then stop.
3. Once the red LED's stop flashing, the generator will start and run for approximately 12 minutes and then shut down. The exerciser is now set to run at this time of day each week.

**Example:** If the "Set Exercise Time" switch is pressed on Saturday afternoon at 2:00 p.m., the generator will start and exercise for approximately 12 minutes every Saturday at 2:00 p.m..

**NOTE:**

**The exerciser will only work in the AUTO mode and will not work unless this procedure is performed. The exerciser will need to be reset every time the 12-volt battery is disconnected and then reconnected, and when the 15A fuse is removed.**

The 16kW unit has a low speed exercise option. Dip switch 1 on the control board is factory set to OFF. This allows the engine to run at a slower speed during weekly exercise periods for quieter operation. If this Dip switch is set to ON, the generator will exercise at it's normal speed.

This DIP switch position is only read at board power up. If the DIP switch position is changed, power to the board must be cycled for the micro controller to recognize the new DIP switch position.

### ◆ 3.4.2 TRANSFER BACK TO UTILITY POWER SOURCE

When utility power has been restored, transfer back to that source and shut down the generator. This can be accomplished as follows:

1. Set the generator's main circuit breaker to its OFF (or OPEN) position.
2. Let the engine run for a minute or two at no-load to stabilize the internal temperatures.
3. Set the generator's AUTO/OFF/MANUAL switch to its OFF (or OPEN) position. The engine should shut down.
4. Check that utility power supply to the transfer switch is turned OFF.



**⚠ Do not attempt to activate the transfer switch manually until all power voltage supplies to the switch have been positively turned off. Failure to turn off all power voltage supplies may result in extremely hazardous and possibly fatal electrical shock.**

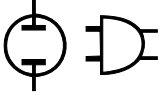

Low speed exercise will be handled as follows:

1. The standard start sequence will be initiated.
2. The unit will run at 2,400 RPM.
3. If utility is lost during exercise, the controller will do the following:
  - Wait 10 seconds for utility to return.
  - If utility returns within 10 seconds, continue to exercise at 2,400 RPM.
  - If utility is still lost after 10 seconds, run the engine up to 3600 RPM and transfer the load. At this time the controller will exit the exercise routine and assume full automatic operation.

## 3.6 PROTECTION SYSTEMS

### ◆ 3.6.1 LOW OIL PRESSURE SWITCH

This switch (Figure 3.3) has normally closed contacts that are held open by engine oil pressure during cranking and operating. Should oil pressure drop below the 8 psi range, switch contacts close, and the engine shuts down. The unit should not be restarted until oil is added. The AUTO/OFF/MANUAL switch must then be turned to OFF and then back to AUTO.

### ◆ 3.6.2 HIGH TEMPERATURE SWITCH

This switch's contacts (Figure 3.3) close if the temperature should exceed approximately 144° C (293° F), initiating an engine shutdown. The generator will automatically restart and the LED on the generator control panel will reset once the temperature has returned to a safe operating level.

**Figure 3.3 – Low Oil Pressure and High Temperature Switches**

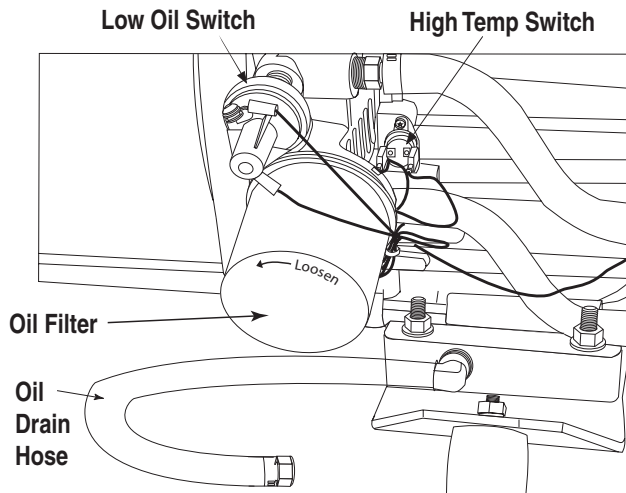

### ◆ 3.6.3 OVERCRANK

This feature prevents the generator from damaging itself when it continually attempts to start and another problem, such as no fuel supply, prevents it from starting. The unit will crank and rest for a preset time limit. Then, it will stop cranking, and the LED on the generator control panel will light indicating an overcrank failure. The AUTO/OFF/MANUAL switch will need to be set to OFF and then back to AUTO to reset the generator control board.

**NOTE:**

**If the fault is not repaired, the overcrank feature will continue to activate.**

#### 3.7.3.1 Approximate Crank Cycle Times

**7kW Units:**

- 15 seconds ON
- 7 seconds OFF
- 7 seconds ON
- 7 seconds OFF
- 7 seconds ON
- 7 seconds OFF
- 7 seconds ON
- 7 seconds OFF
- 7 seconds ON
- 7 seconds OFF
- 7 seconds ON
- 7 seconds OFF
- 7 seconds ON

If the unit fails to start, the overcrank alarm LED will be illuminated.

**10kW, 13kW and 16kW Units:**

- 16 seconds ON
- 7 seconds OFF
- 16 seconds ON
- 7 seconds OFF
- 7 seconds ON
- 7 seconds OFF
- 7 seconds ON
- 7 seconds OFF
- 7 seconds ON
- 7 seconds OFF
- 7 seconds ON
- 7 seconds OFF

If the unit fails to start, the overcrank alarm LED will be illuminated.

### ◆ 3.6.4 OVERSPEED

This feature protects the generator from damage by shutting it down if it happens to run faster than the preset limit. This protection also prevents the generator from supplying an output that could potentially damage appliances connected to the generator circuit. Contact the nearest Authorized Dealer if this failure occurs.

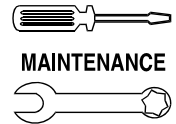

### ◆ 3.6.5 RPM SENSOR FAILURE

During cranking, if the board does not see a valid RPM signal within three (3) seconds, it will shut down and latch out on RPM sensor loss.

During running, if the RPM signal is lost for one full second the board will shut down the engine, wait 15 seconds, then re-crank the engine.

- If an RPM signal is not detected within the first three (3) seconds of cranking, the control board will shut the engine down and latch out on RPM sensor loss.
- If the RPM signal is detected the engine will start and run normally. If the RPM signal is subsequently lost again, the control board will try one more re-crank attempt before latching out and flashing the overspeed LED.

### ◆ 3.6.6 LOW BATTERY

The microprocessor will continually monitor the battery voltage and turn on the Low Battery LED if the battery voltage falls below 11.0 volts for one (1) minute. No other action is taken on a low battery condition. Low battery voltage is a non-latching alarm which will automatically clear if the battery voltage rises above 11.0 volts. Battery voltage is NOT monitored during the crank cycle.

## 4.1 FUSES

The 15-amp fuse on the generator panel protects the DC control circuit against overload (Figure 4.1). This fuse is wired in series with the battery output lead to the panel. If this fuse element has melted open, the engine will not be able to crank or start. Replace this fuse using only an identical 15-amp replacement fuse. To replace the fuse, push the fuse holder cap down and rotate it counterclockwise. Whenever the fuse is removed or replaced, the exercise timer needs to be reset.

Figure 4.1 – Generator Control Panel

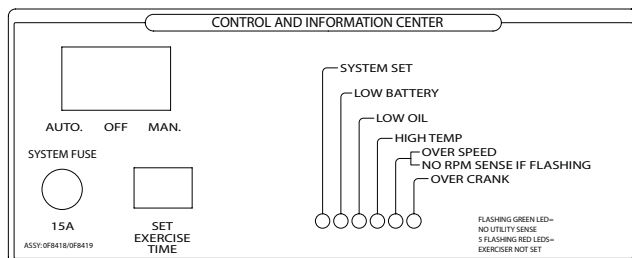

## 4.2 CHECKING THE ENGINE OIL LEVEL

For oil capacities, see the Specifications section. For engine oil recommendations, see the Engine Oil Recommendations section. To check the engine oil level, proceed as follows (Figures 4.2, 4.3 and 4.4):

1. Move the AUTO/OFF/ MANUAL switch to the OFF position.
2. Remove the dipstick and wipe it dry with a clean cloth.
3. Completely insert the dipstick; then, remove it again. The oil level should be at the dipstick "Full" mark. If necessary, add oil to the "Full" mark only. DO NOT FILL ABOVE THE "FULL" MARK.

—▲ CAUTION ▲—

▲ Never operate the engine with the oil level below the "Add" mark on the dipstick. Doing this could damage the engine.

4. Install the dipstick.
5. Reset the AUTO/OFF/MANUAL switch to its original position.

Figure 4.2 — Oil Dipstick and Fill, 7kW

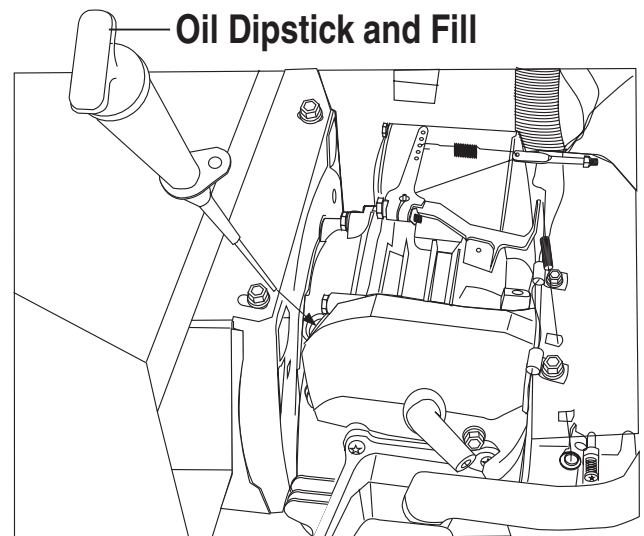

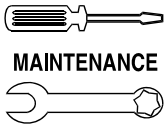

MAINTENANCE

## Section 4 – Maintenance

### Air-cooled Generators

Figure 4.3 — Oil Dipstick and Fill, 10kW

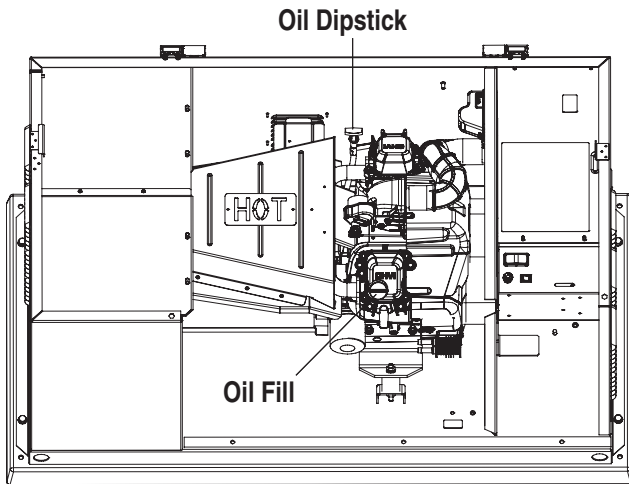
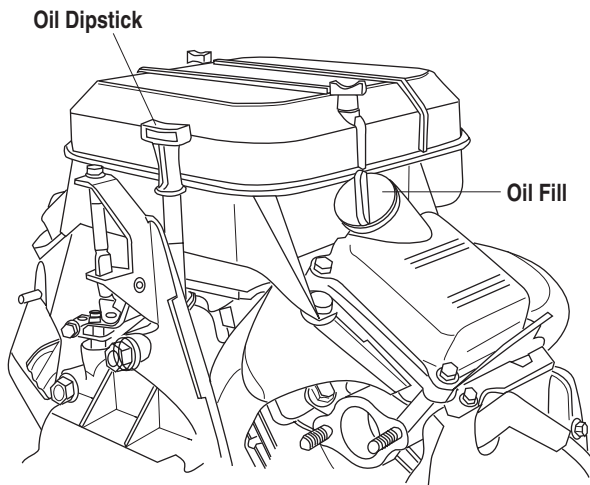

Figure 4.4 — Oil Dipstick and Fill, 13kW and 16kW



## 4.3 CHANGING THE ENGINE OIL

### ◆ 4.3.1 OIL CHANGE INTERVALS

See the "Service Schedule" section.

### ◆ 4.3.2 ENGINE OIL RECOMMENDATIONS

Use all season SAE 5W-30 synthetic oil or use SAE 30 oil of American Petroleum Institute (API) Service Class SG, SH, SJ or SL.



CAUTION

⚠ Any attempt to crank or start the engine before it has been properly serviced with the recommended oil may result in an engine failure.

### ◆ 4.3.3 OIL & OIL FILTER CHANGE PROCEDURE

To change the oil, proceed as follows:

1. Start the engine by moving the AUTO/OFF/MANUAL switch to MANUAL and run until it is thoroughly warmed up. Then shut OFF the engine by moving the switch to the OFF position.
2. Immediately after the engine shuts OFF, pull the oil drain hose (Figure 4.5) free of its retaining clip. Remove the cap from the hose and drain the oil into a suitable container.
3. After the oil has drained, replace the cap onto the end of the oil drain hose. Retain the hose in the clip.

Figure 4.5 – Oil Drain Hose and Filter

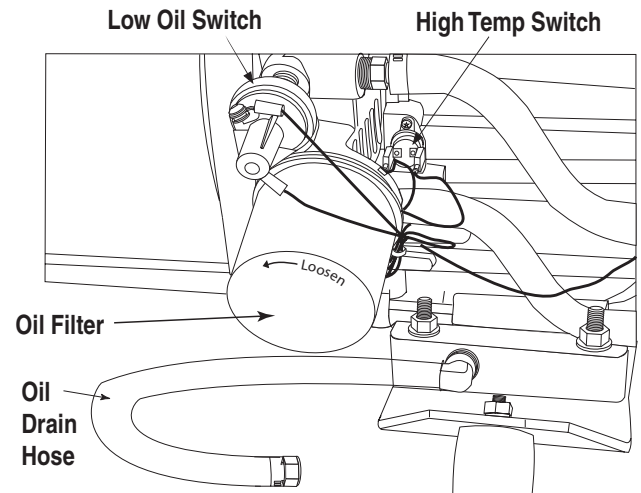

Change the engine oil filter as follows:

1. With the oil drained, remove the old oil filter by turning it counterclockwise.
2. Apply a light coating of clean engine oil to the gasket of the new filter. See the Specifications section for recommended filter.
3. Screw the new filter on by hand until its gasket lightly contacts the oil filter adapter. Then, tighten the filter an additional 3/4 to one turn (Figure 4.4).
4. Refill with the proper recommended oil (see the Engine Oil Recommendations section). See the Specifications section for oil capacities.
5. Start the engine, run for one (1) minute, and check for leaks.
6. Shutdown and recheck oil level, add as needed. DO NOT OVER FILL.
7. Reset the AUTO/OFF/MANUAL switch to the AUTO position.

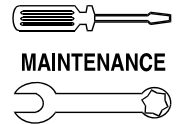

## 4.4 CHANGING THE ENGINE AIR CLEANER

### ◆ 4.4.1 7, 13, AND 16KW GENERATORS

See Figures 1.1 and 1.2, for the location of the air cleaner. Use the following procedures (Figure 4.6, 7kW; Figure 4.8, 13/16kW):

1. Lift the roof and remove the door.
2. Turn the two screws counterclockwise to loosen.
3. Remove the cover and air filter.
4. Wipe away dust or debris from inside of the air box and around edges.
5. Install the new air cleaner into the air box.
6. Install the cover. Turn the two cover screws clockwise to tighten.

See the Service Schedule section for air cleaner maintenance. See the Specifications section for air filter replacement part number.

Figure 4.6 — 7 kW, Engine Air Cleaner Location

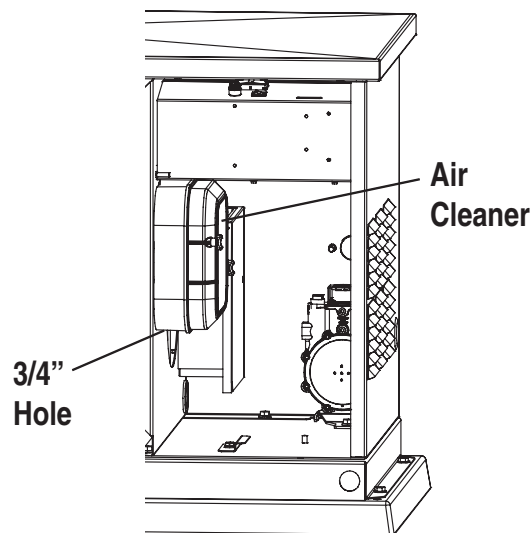

### ◆ 4.4.2 10KW GENERATORS

See Figure 1.2 for the location of the air cleaner. Use the following procedure (Figure 4.7):

1. Lift the roof and remove the door.
2. Turn the worm gear clamp screw counterclockwise to loosen.
3. Pull the old filter off the divider panel hub.
4. Wipe away dust or debris from the panel hub.
5. Install the new air cleaner onto the hub.
6. Turn the worm gear clamp screw clockwise to tighten.
7. Replace door and roof.

Figure 4.7 — 10kW Engine Air Cleaner

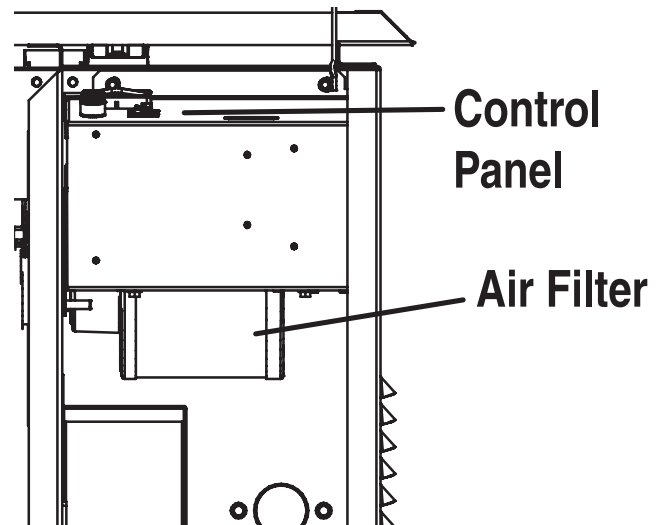
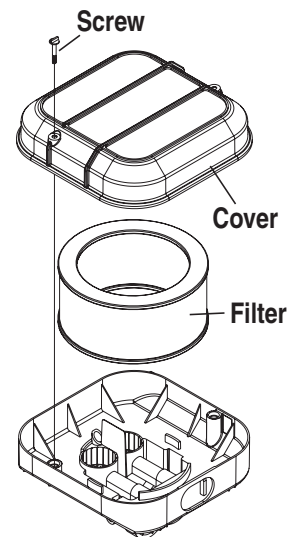

Figure 4.8 — 13 kW and 16 kW Engine Air Cleaner



## 4.5 SPARK PLUG(S)

Reset the spark plug(s) gap or replace the spark plug(s) as necessary. See the Service Schedule section for maintenance requirements.

1. Clean the area around the base of the spark plug(s) to keep dirt and debris out of the engine.
2. Remove the spark plug(s) and check the condition. Replace the spark plug(s) if worn or if reuse is questionable. See the Service Schedule section for recommended inspection. Clean by scraping or washing using a wire brush and commercial solvent. Do not blast the spark plug(s) to clean.

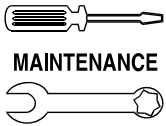

3. Check the spark plug gap using a wire feeler gauge. Adjust the gap to 0.76 mm (0.030 inch) for 7 and 10kW; and 1.02 mm (0.040 inch) for 13/16 kW by carefully bending the ground electrode (Figure 4.9).

Figure 4.9 – Setting the Spark Plug Gap

SET PLUG GAP AT 0.76 mm (.030 inch) - 7 & 10kW;  
1.02 mm (.040 inch) - 13 & 16kW

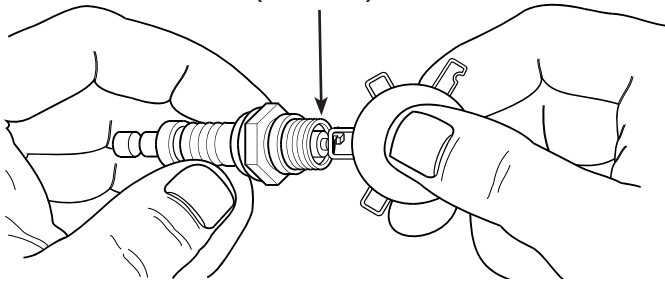

## 4.6 BATTERY MAINTENANCE

The battery should be inspected per the "Service Schedule" section. The following procedure should be followed for inspection:

1. Inspect the battery posts and cables for tightness and corrosion. Tighten and clean as necessary.
2. Check the battery fluid level of unsealed batteries and, if necessary, fill with Distilled Water Only. Do not use tap water in batteries.
3. Have the state of charge and condition checked. This should be done with an automotive-type battery hydrometer.

### ⚠ DANGER ⚠

- ⚠ Do not dispose of the battery in a fire. The battery is capable of exploding.
- ⚠ A battery presents a risk of electrical shock and high short circuit current. The following precautions are to be observed when working on batteries:

- Remove the 15A fuse from the generator control panel.
- Remove watches, rings or other metal objects;
- Use tools with insulated handles;
- Wear rubber gloves and boots;
- Do not lay tools or metal parts on top of the battery; and
- Disconnect charging source prior to connecting or disconnecting battery terminals.

### ⚠ WARNING ⚠

- ⚠ Do not open or mutilate the battery. Released electrolyte has been known to be harmful to the skin and eyes, and to be toxic.

- ⚠ The electrolyte is a dilute sulfuric acid that is harmful to the skin and eyes. It is electrically conductive and corrosive. The following procedures are to be observed:

- Wear full eye protection and protective clothing;
- Where electrolyte contacts the skin, wash it off immediately with water;
- Where electrolyte contacts the eyes, flush thoroughly and immediately with water and seek medical attention; and
- Spilled electrolyte is to be washed down with an acid neutralizing agent. A common practice is to use a solution of 1 pound (500 grams) bicarbonate of soda to 1 gallon (4 liters) of water. The bicarbonate of soda solution is to be added until the evidence of reaction (foaming) has ceased. The resulting liquid is to be flushed with water and the area dried.

- ⚠ Lead-acid batteries present a risk of fire because they generate hydrogen gas. The following procedures are to be followed:

- DO NOT SMOKE when near the battery;
- DO NOT cause flame or spark in battery area; and
- Discharge static electricity from body before touching the battery by first touching a grounded metal surface.

- ⚠ Be sure the AUTO/OFF/MANUAL switch is set to the OFF position before connecting the battery cables. If the switch is set to AUTO or MANUAL, the generator can crank and start as soon as the battery cables are connected.

- ⚠ Be sure the utility power supply is turned off and the 15A fuse is removed from the generator control panel, or sparking may occur at the battery posts as the cables are attached and cause an explosion.

## 4.7 ADJUSTING GH-410/GT-530/990 VALVE CLEARANCE

After the first six (6) months of operation, check the valve clearance in the engine, adjust if necessary.

**Important:** If feeling uncomfortable about doing this procedure or the proper tools are not available, please contact the Authorized Dealer for service assistance. This is a very important step to insure longest life for the engine.

**To check valve clearance:**

- The engine should be cool before checking. If valve clearance is 0.002" - 0.004" (0.05 - 0.1mm), adjustment is not needed.



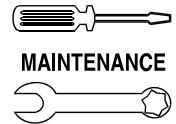

- Remove spark plug wires and position wires away from plugs.
- Remove spark plugs.
- Make sure the piston is at Top Dead Center (TDC) of its compression stroke (both valves closed). To get the piston at TDC, remove the intake screen at the front of the engine to gain access to the flywheel nut. Use a large socket and socket wrench to rotate the nut and hence the engine in a clockwise direction. While watching the piston through the spark plug hole. The piston should move up and down. The piston is at TDC when it is at its highest point of travel.

**To adjust valve clearance (if necessary):**

- Make sure the engine is at 60° to 80° F.
- Make sure that the spark plug wire is removed from the spark plug and out of the way.
- Remove the four screws attaching the valve cover with a #2 or #3 Phillips screwdriver.
- Loosen the rocker jam nut. Use an 10mm allen wrench to turn the pivot ball stud while checking clearance between the rocker arm and the valve stem with a feeler gauge. Correct clearance is 0.002-0.004 inch (0.05-0.1 mm).

**NOTE:**

**Hold the rocker arm jam nut in place as the pivot ball stud is turned.**

When valve clearance is correct, hold the pivot ball stud in place with the allen wrench and tighten the rocker arm jam nut. Tighten the jam nut to 174 in/lbs. torque. After tightening the jam nut, recheck valve clearance to make sure it did not change.

**Figure 4.10 - Valve Clearance Adjustment**

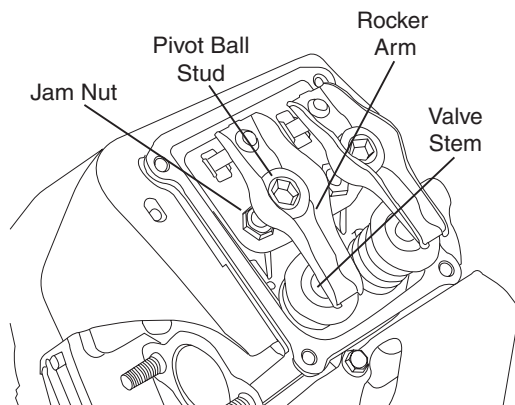

- Install new valve cover gasket.
- Re-attach the valve cover.

**NOTE:**

**Start all four screws before tightening or it will not be possible to get all the screws in place. Make sure the valve cover gasket is in place.**

- Install spark plugs.
- Re-attach the spark plug wire to the spark plug.
- On the GT-530 and GT-990, repeat the process for the other cylinder.

## 4.8 COOLING SYSTEM

Air inlet and outlet openings in the generator compartment must be open and unobstructed for continued proper operation. This includes such obstructions as high grass, weeds, brush, leaves and snow.

Without sufficient cooling and ventilating air flow, the engine/generator quickly overheats, which causes it to quickly shut down. (See Figure 4.11 for vent locations.)

Make sure the doors and roof are in place during operation as running the generator with them removed can effect cooling air movement.

**Figure 4.11 – Cooling Vent Locations**

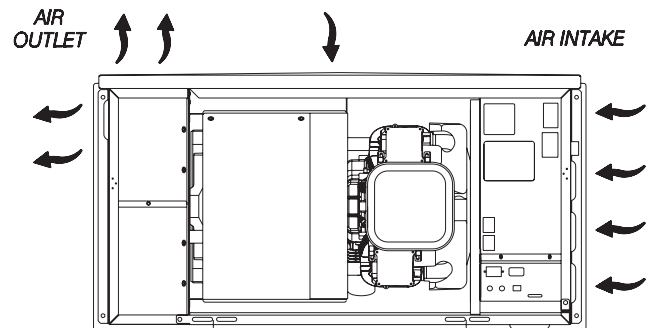

**WARNING**

The exhaust from this product gets extremely hot and remains hot after shutdown. High grass, weeds, brush, leaves, etc. must remain clear of the exhaust. Such materials may ignite and burn from the heat of the exhaust system.

**CAUTION**

The maximum ambient temperature for the generator is 40° C (104° F).

## 4.9 ATTENTION AFTER SUBMERSION

If the generator has been submerged in water, it **must not** be started and operated. Following any submersion in water, have an Authorized Dealer thoroughly clean, dry and inspect the generator. If the structure (ex. home) has been flooded, it should be inspected by a certified electrician to ensure there won't be any electrical problems during generator operation or when utility is returned.

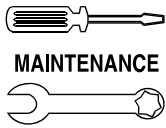

MAINTENANCE

## Section 4 – Maintenance

### Air-cooled Generators

---

## 4.10 CORROSION PROTECTION

Periodically wash and wax the enclosure using automotive type products. Frequent washing is recommended in salt water/coastal areas. Spray engine linkages with a light oil such as WD-40.

## 4.11 OUT OF SERVICE PROCEDURE

### ◆ 4.11.1 REMOVAL FROM SERVICE

---

If the generator cannot be exercised every seven days, and will be out of service longer than 90 days, prepare the generator for storage as follows:

1. Start the engine and let it warm up.
2. Close the fuel shutoff valve in the fuel supply line and allow the unit to shut down.
3. Once the unit has shut down, it will signal a low oil fault.
4. Set the generator's main circuit breaker to its OFF (or OPEN) position.
5. Set the AUTO/OFF/MANUAL switch to OFF and turn off the utility power to the transfer switch. Remove the 15A fuse from the generator control panel. Disconnect the battery cables as outlined in "General Hazards".
6. While the engine is still warm from running, drain the oil completely. Refill the crankcase with oil. See "Engine Oil Recommendations".
7. Attach a tag to the engine indicating the viscosity and classification of the oil in the crankcase.
8. Remove the spark plug(s) and spray fogging agent into the spark plug(s) threaded openings. Reinstall and tighten the spark plug(s).
9. Remove the battery and store it in a cool, dry room on a wooden board. Never store the battery on any concrete or earthen floor.
10. Clean and wipe the entire generator.

### ◆ 4.11.2 RETURN TO SERVICE

---

To return the unit to service after storage, proceed as follows:

1. Verify that utility power is turned off and that the AUTO/OFF/MANUAL switch is set to OFF.
2. Check the tag on the engine for oil viscosity and classification. Verify that the correct recommended oil is used in the engine (see the Engine Oil Recommendations section). If necessary, drain and refill with the proper oil.
3. Check the state of the battery. Fill all cells of unsealed batteries to the proper level with distilled water. **DO NOT USE TAP WATER IN THE BATTERY.** Recharge the battery to 100 percent state of charge, or, if defective, replace the battery. See "Specifications," for type and size.
4. Clean and wipe the entire generator.
5. Make sure the 15A fuse is removed from the generator control panel. Reconnect the battery. Observe battery polarity. Damage may occur if the battery is connected incorrectly.
6. Open the fuel shutoff valve.
7. Insert the 15A fuse into the generator control panel. Start the unit by moving the AUTO/OFF/MANUAL switch to MANUAL. Allow the unit to warm up thoroughly.
8. Stop the unit by setting the AUTO/OFF/MANUAL switch to OFF.
9. Turn on the utility power to the transfer switch.
10. Set the AUTO/OFF/MANUAL switch to AUTO.
11. The generator is now ready for service.

#### **NOTE:**

**If the battery was dead or disconnected, the exercise timer must be reset.**

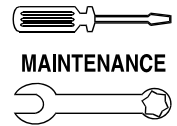

## 4.12 SERVICE SCHEDULE

**ATTENTION:** It is recommended that all service work be performed by the nearest Authorized Dealer.

SYSTEM/COMPONENT	PROCEDURE			FREQUENCY
X = Action R = Replace as Necessary * = Notify Dealer if Repair is Needed.	Inspect	Change	Clean	W = Weekly M = Monthly Y = Yearly
<b>FUEL</b>				
Fuel lines and connections*	X			M
<b>LUBRICATION</b>				
Oil level	X			M
Oil		X		EVERY 100 HOURS**, AND Y
Oil filter		X		EVERY 100 HOURS**, AND Y
<b>COOLING</b>				
Enclosure louvers	X		X	W
<b>BATTERY</b>				
Remove corrosion, ensure dryness	X		X	M
Clean and tighten battery terminals	X		X	M
Check charge state	X	R		EVERY 6 M
Electrolyte level (unsealed batteries only)*	X	R		EVERY 6 M
<b>ENGINE AND MOUNTING</b>				
Air cleaner	X	R		Y
Spark plug(s)	X	R		Y
<b>GENERAL CONDITION</b>				
Vibration, Noise, Leakage, Temperature*	X			M
<b>COMPLETE TUNE-UP*</b>	TO BE COMPLETED BY AN AUTHORIZED DEALER			Y

\* Contact the nearest Authorized Dealer for assistance if necessary.

\*\* Change oil and filter after first eight (8) hours of operation and then every 100 hours thereafter. Change sooner when operating under a heavy load or in a dusty or dirty environment or in high ambient temperatures.



## 5.1 TROUBLESHOOTING GUIDE

<b>Problem</b>	<b>Cause</b>	<b>Correction</b>
The engine will not crank.	<ol style="list-style-type: none"> <li>1. Fuse blown.</li> <li>2. Loose, corroded or defective battery cables.</li> <li>3. Defective starter contactor. (7 kW)</li> <li>4. Defective starter motor.</li> <li>5. Dead Battery.</li> </ol>	<ol style="list-style-type: none"> <li>1. Correct short circuit condition, replace 15A fuse in generator control panel.</li> <li>2. Tighten, clean or replace as necessary.</li> <li>3. *</li> <li>4. *</li> <li>5. Charge or replace battery.</li> </ol>
The engine cranks but will not start.	<ol style="list-style-type: none"> <li>1. Out of fuel.</li> <li>2. Defective fuel solenoid (FS).</li> <li>3. Open #14 wire from engine control board.</li> <li>4. Defective spark plug(s).</li> <li>5. Valve lash out of adjustment.</li> <li>6. Choke not operating.</li> </ol>	<ol style="list-style-type: none"> <li>1. Replenish fuel/Turn on fuel valve.</li> <li>2. *</li> <li>3. *</li> <li>4. Clean, re-gap or replace plug(s).</li> <li>5. Reset valve lash.</li> <li>6. Verify choke plate moves freely.</li> </ol>
The engine starts hard and runs rough.	<ol style="list-style-type: none"> <li>1. Air cleaner plugged or damaged.</li> <li>2. Defective spark plug(s).</li> <li>3. Fuel regulator not set.</li> <li>4. Fuel pressure incorrect.</li> <li>5. Fuel selector in wrong position.</li> <li>6. Choke remains closed.</li> </ol>	<ol style="list-style-type: none"> <li>1. Check, replace air cleaner.</li> <li>2. Clean, re-gap or replace plug(s).</li> <li>3. Set Fuel Regulator.</li> <li>4. Confirm fuel pressure to regulator is 10-12" water column (0.36-0.43 psi) for LP, and 5-7" water column (0.18-0.25 psi) for natural gas.</li> <li>5. Move selector to correct position.</li> <li>6. Verify choke plate moves freely.</li> </ol>
The AUTO/OFF/MANUAL switch is set to OFF, but the engine continues to run.	<ol style="list-style-type: none"> <li>1. Defective switch.</li> <li>2. AUTO/OFF/MANUAL switch wired incorrectly.</li> <li>3. Defective control board.</li> </ol>	<ol style="list-style-type: none"> <li>1. *</li> <li>2. *</li> <li>3. *</li> </ol>
There is no AC output from the generator.	<ol style="list-style-type: none"> <li>1. Main line circuit breaker is in the OFF (or OPEN) position.</li> <li>2. Generator internal failure.</li> </ol>	<ol style="list-style-type: none"> <li>1. Reset circuit breaker to ON (or CLOSED).</li> <li>2. *</li> </ol>
There is no transfer to standby after utility source failure.	<ol style="list-style-type: none"> <li>1. Defective transfer switch coil.</li> <li>2. Defective transfer relay.</li> <li>3. Transfer relay circuit open.</li> <li>4. Defective control logic board.</li> </ol>	<ol style="list-style-type: none"> <li>1. *</li> <li>2. *</li> <li>3. *</li> <li>4. *</li> </ol>
Unit consumes large amounts of oil.	<ol style="list-style-type: none"> <li>1. Engine over filled with oil.</li> <li>2. Engine breather defective.</li> </ol>	<ol style="list-style-type: none"> <li>1. Adjust oil to proper level.</li> <li>2. *</li> </ol>

**\*Contact the nearest Authorized Dealer for assistance.**





---

**Section 6 – Notes**  
**Air-cooled Generators**

<b>NOTES</b>
--------------

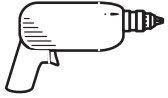

Section 7 – Mounting Dimensions

Air-cooled Generators  
Drawing No. 0F9424-B

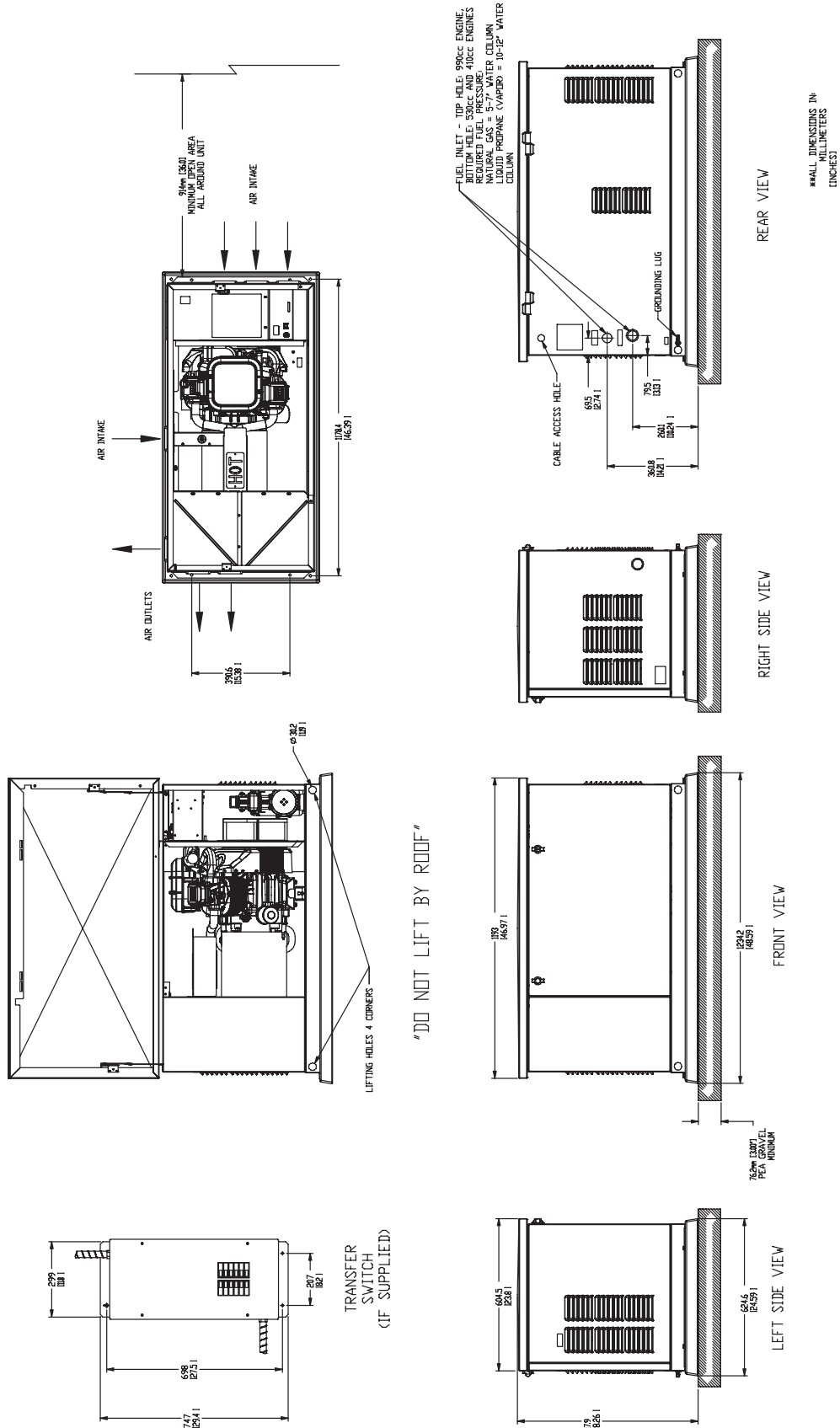



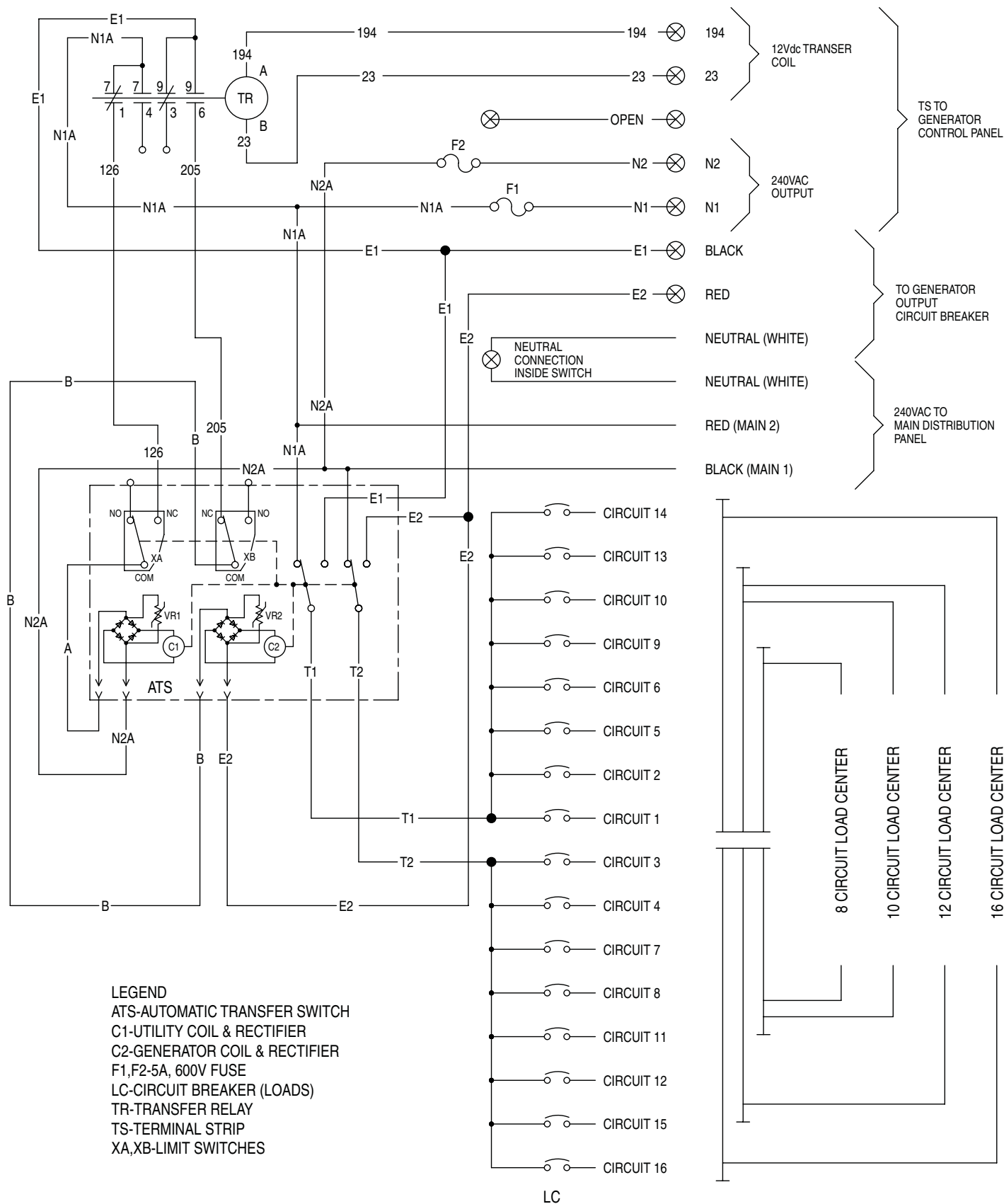

LEGEND  
 ATS-AUTOMATIC TRANSFER SWITCH  
 C1-UTILITY COIL & RECTIFIER  
 C2-GENERATOR COIL & RECTIFIER  
 F1,F2-5A, 600V FUSE  
 LC-CIRCUIT BREAKER (LOADS)  
 TR-TRANSFER RELAY  
 TS-TERMINAL STRIP  
 XA,XB-LIMIT SWITCHES

LC

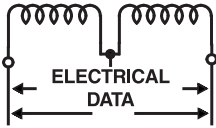

## Section 8 – Electrical Data

### Air-cooled Generators

#### Wiring Diagram – 10, 13 & 16kW, V-Twin – Drawing No. 0F7822

DIAGRAM KEY

- BA - BRUSH ASSEMBLY
- BCR - BATTERY CHARGE RELAY
- CB - MAIN OUTPUT BREAKER
- CS - IDLE CHOKE SOLENOID
- C1 - ENGINE HARNESS
- C2 - ALTERNATOR HARNESS
- C3 - SOLENOID HARNESS
- DSW - PCB MOUNTED DIP SWITCH
- FS1 - FUEL SOLENOID
- FS2 - FUEL SOLENOID (530cc V-TWIN ONLY)
- F1 - FUSE 15 AMP
- GRD 1 - GROUND CONNECTIONS IN CONTROL PANEL
- GRD 2 - GROUND CONNECTIONS AT ENGINE
- HTO - HIGH OIL TEMPERATURE SWITCH
- IC - IN-LINE CONNECTOR
- ICT - IDLE CURRENT TRANSFORMER
- IM1 - IGNITION MODULE, CYL 1
- IM2 - IGNITION MODULE, CYL 2
- LOP - LOW OIL PRESSURE SWITCH
- SC - STARTER CONTACTOR
- SCR - STARTER CONTACTOR RELAY
- SM - STARTER MOTOR
- SP1 - SPARK PLUG, CYL 1
- SP2 - SPARK PLUG, CYL 2
- SW1 - AUTO / OFF / MANUAL SWITCH
- SW2 - SET EXERCISE SWITCH
- TB - INSULATED TERMINAL BLOCK, 4 TAB
- TS - INSULATED TERMINAL STRIP, 4 POSITION
- TX - TRANSFORMER, 16 Vac 56 VA & 16 Vac 1 VA (DUAL SEC.)

#### ENGINE WIRING

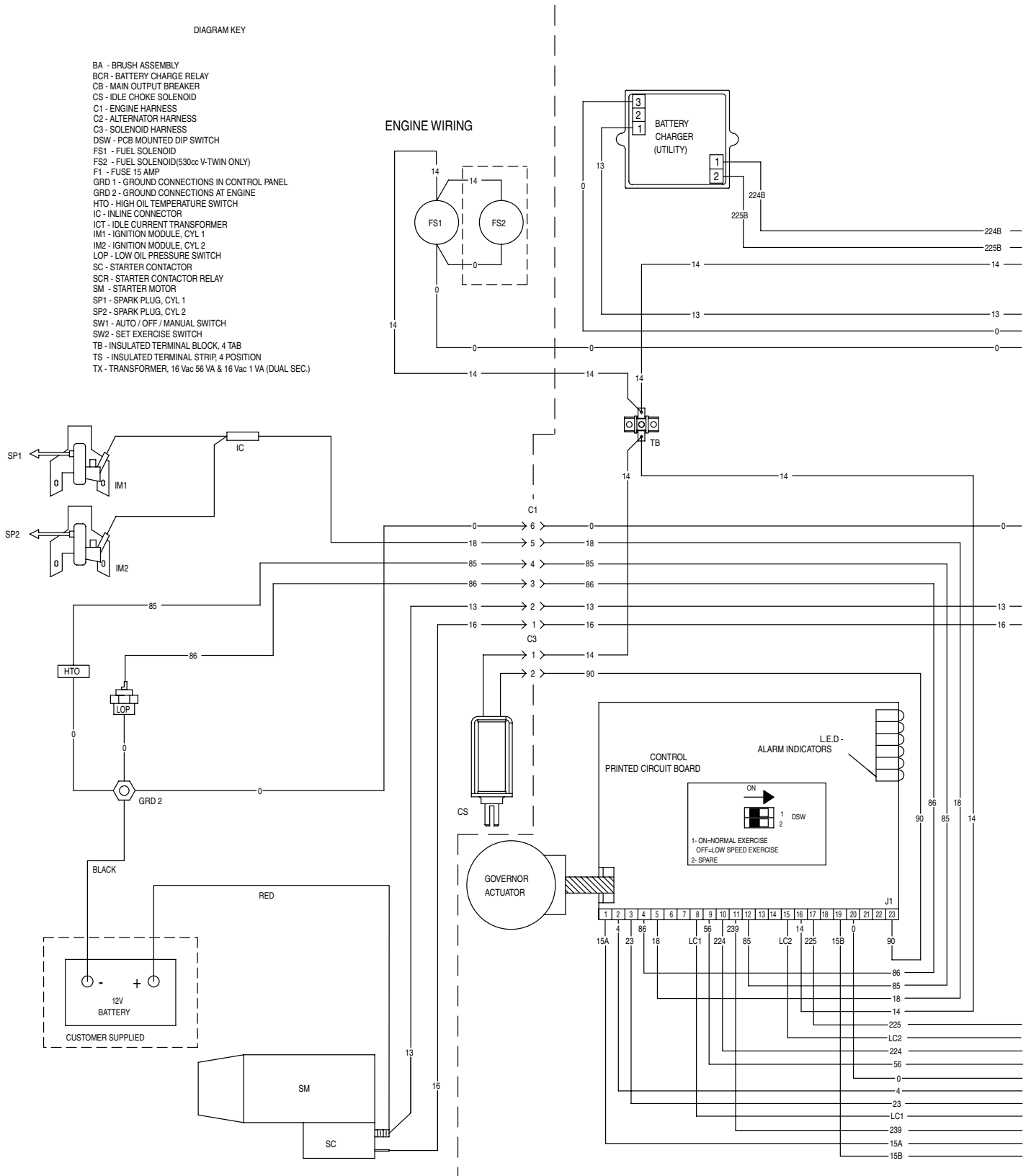

Section 8 – Electrical Data

Air-cooled Generators

Wiring Diagram – 10, 13 & 16kW, V-Twin – Drawing No. 0F7822

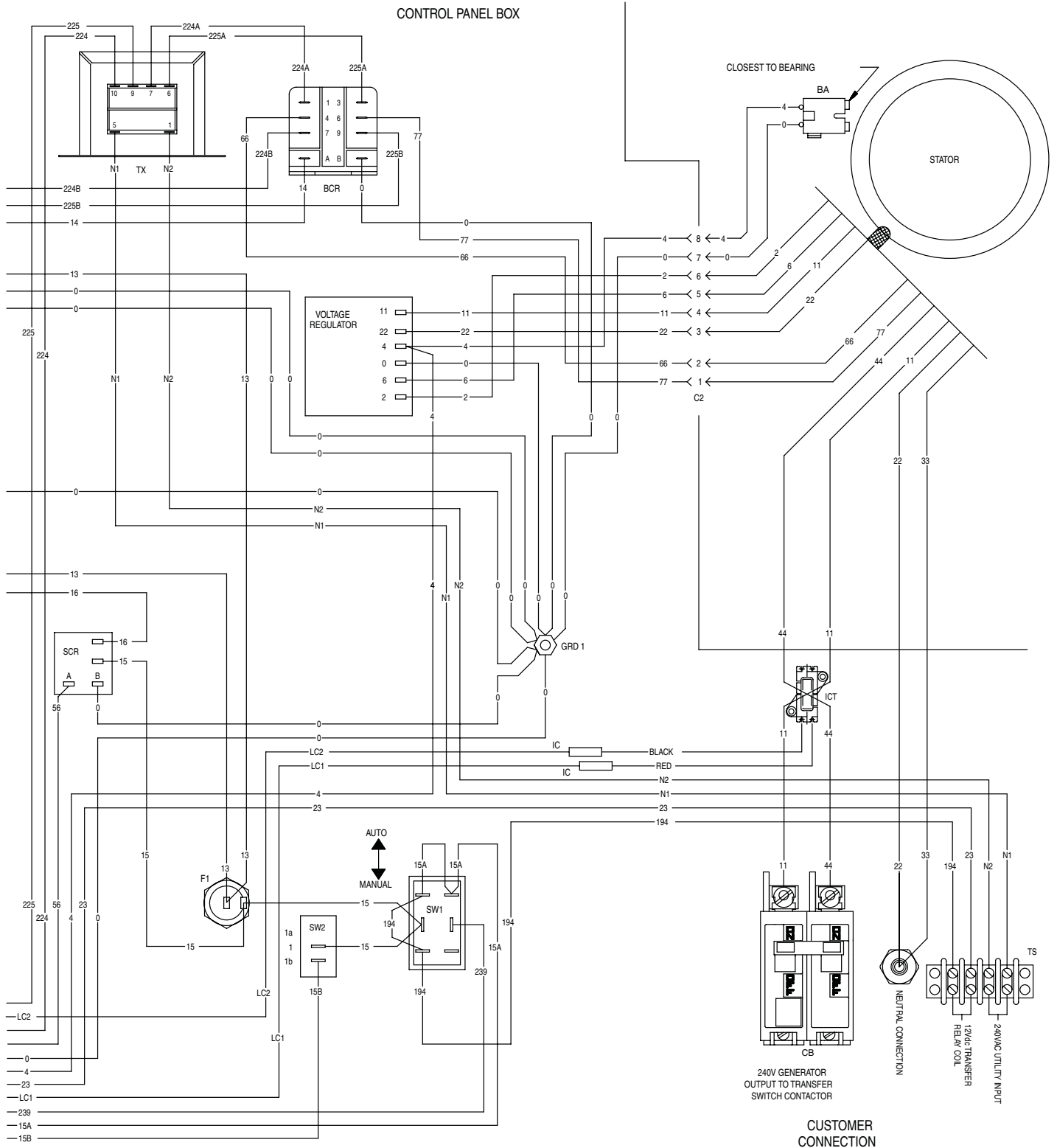
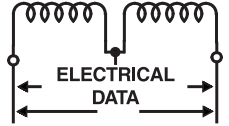

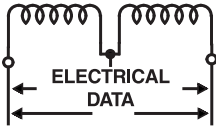

**Section 8 – Electrical Data**

**Air-cooled Generators**

**Electrical Schematic – 10, 13 & 16kW, V-Twin – Drawing No. 0F7823**

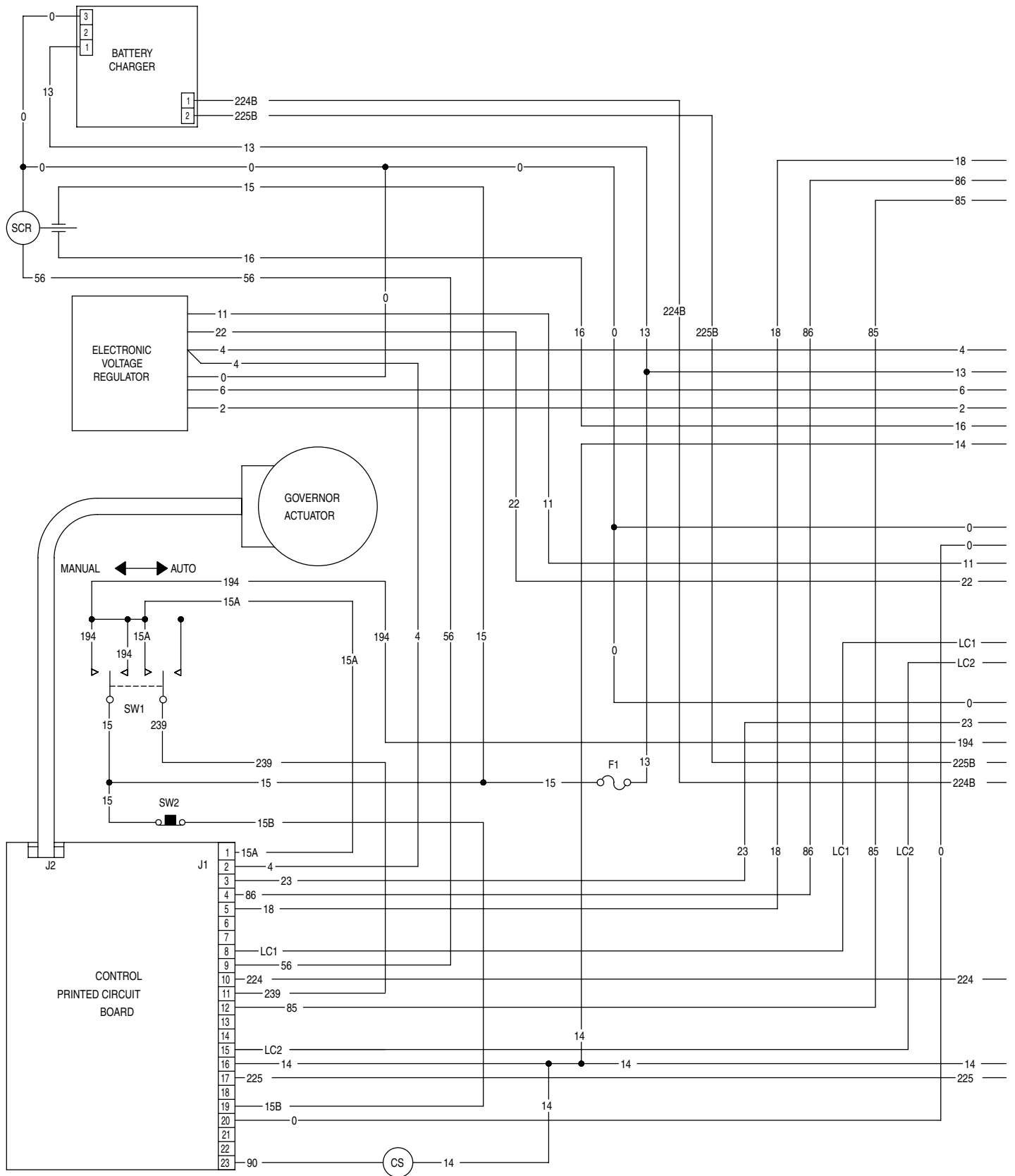

## Section 8 – Electrical Data

### Air-cooled Generators Electrical Schematic – 10, 13 & 16kW, V-Twin – Drawing No. 0F7823

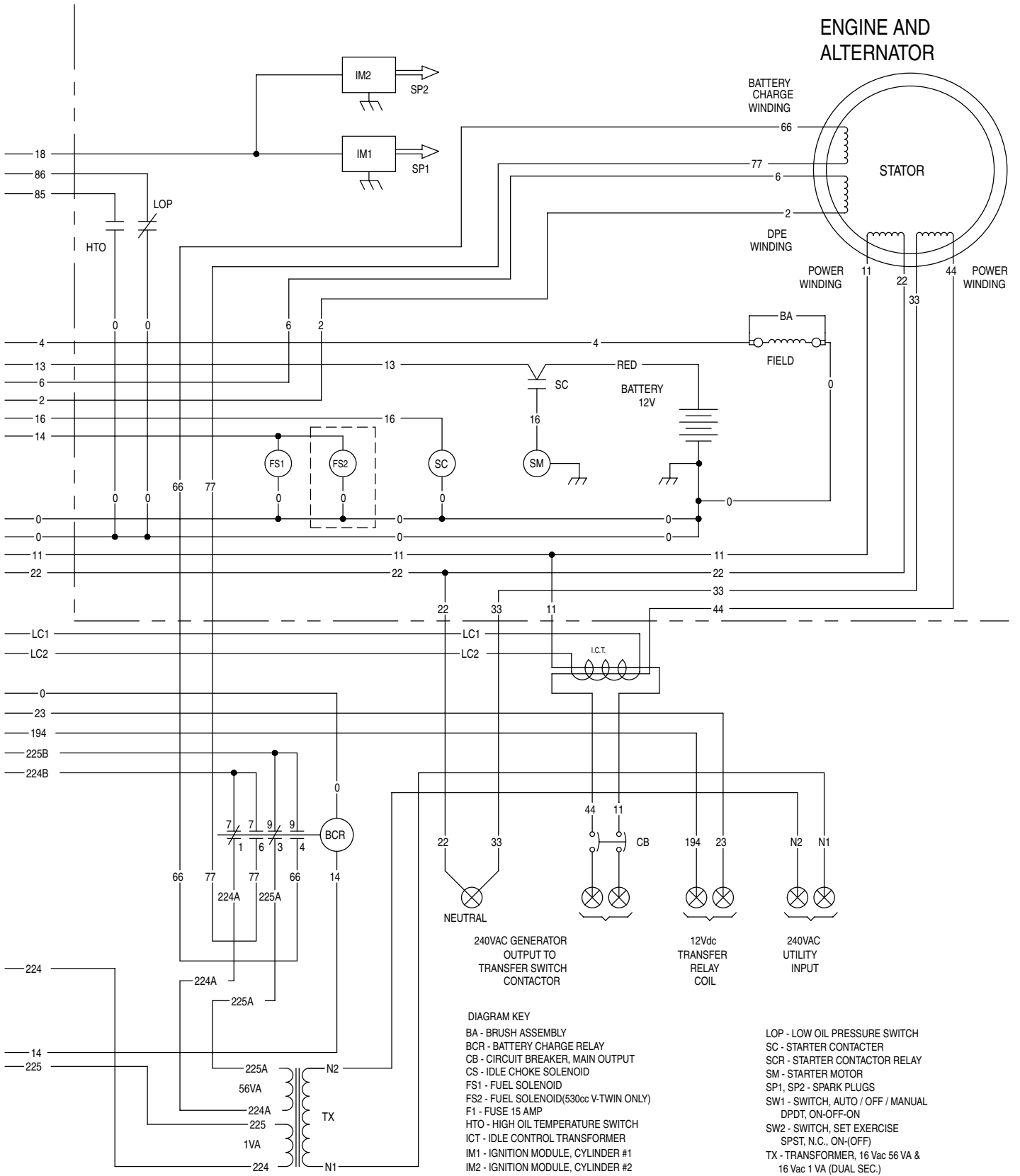
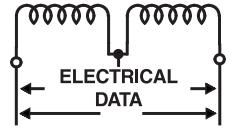

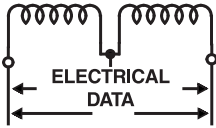

## Section 8 – Electrical Data

### Air-cooled Generators

#### Wiring Diagram – 7kW, Single Cylinder – Drawing No. 0F7820

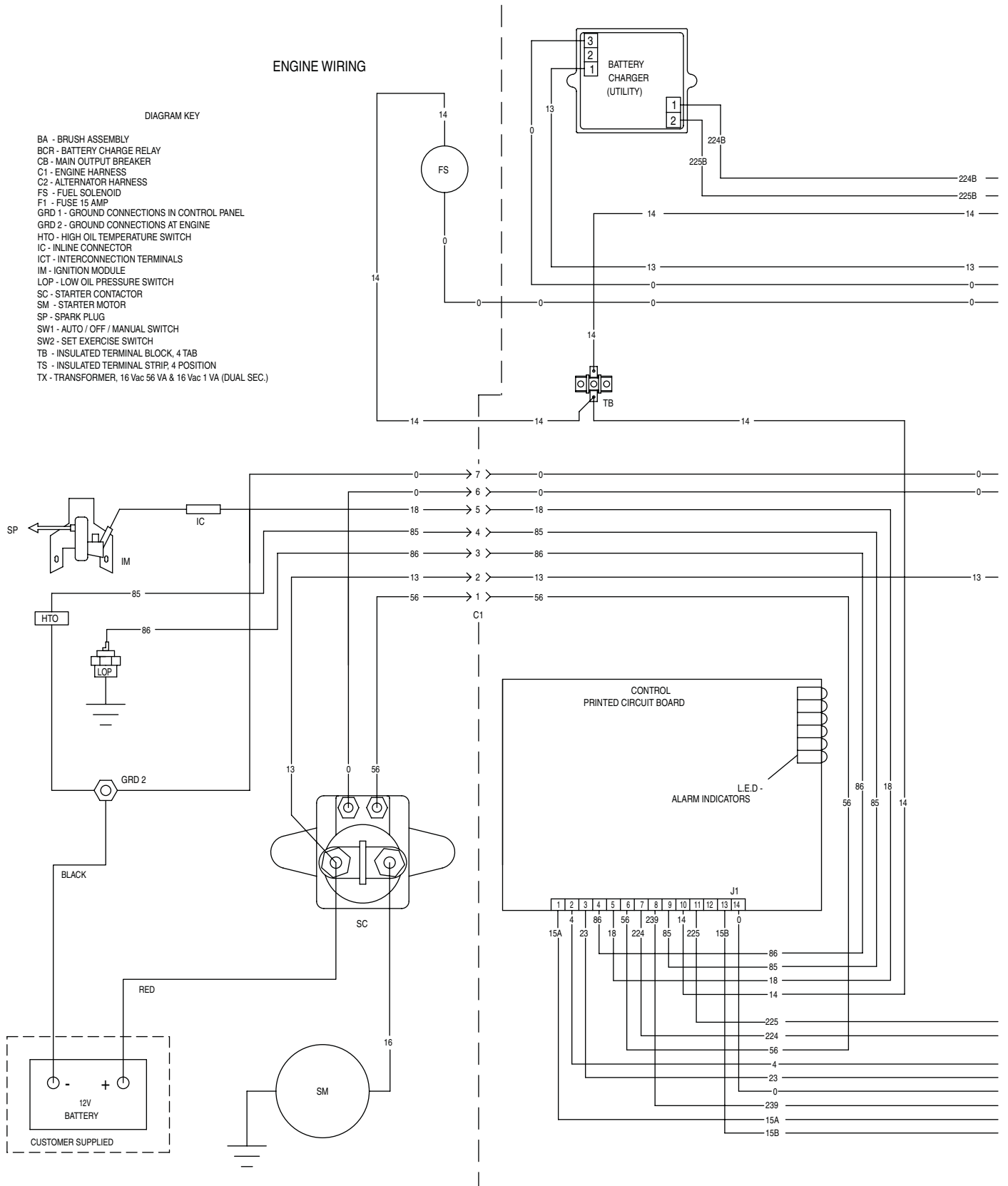

Section 8 – Electrical Data

Air-cooled Generators

Wiring Diagram – 7kW, Single Cylinder – Drawing No. 0F7820

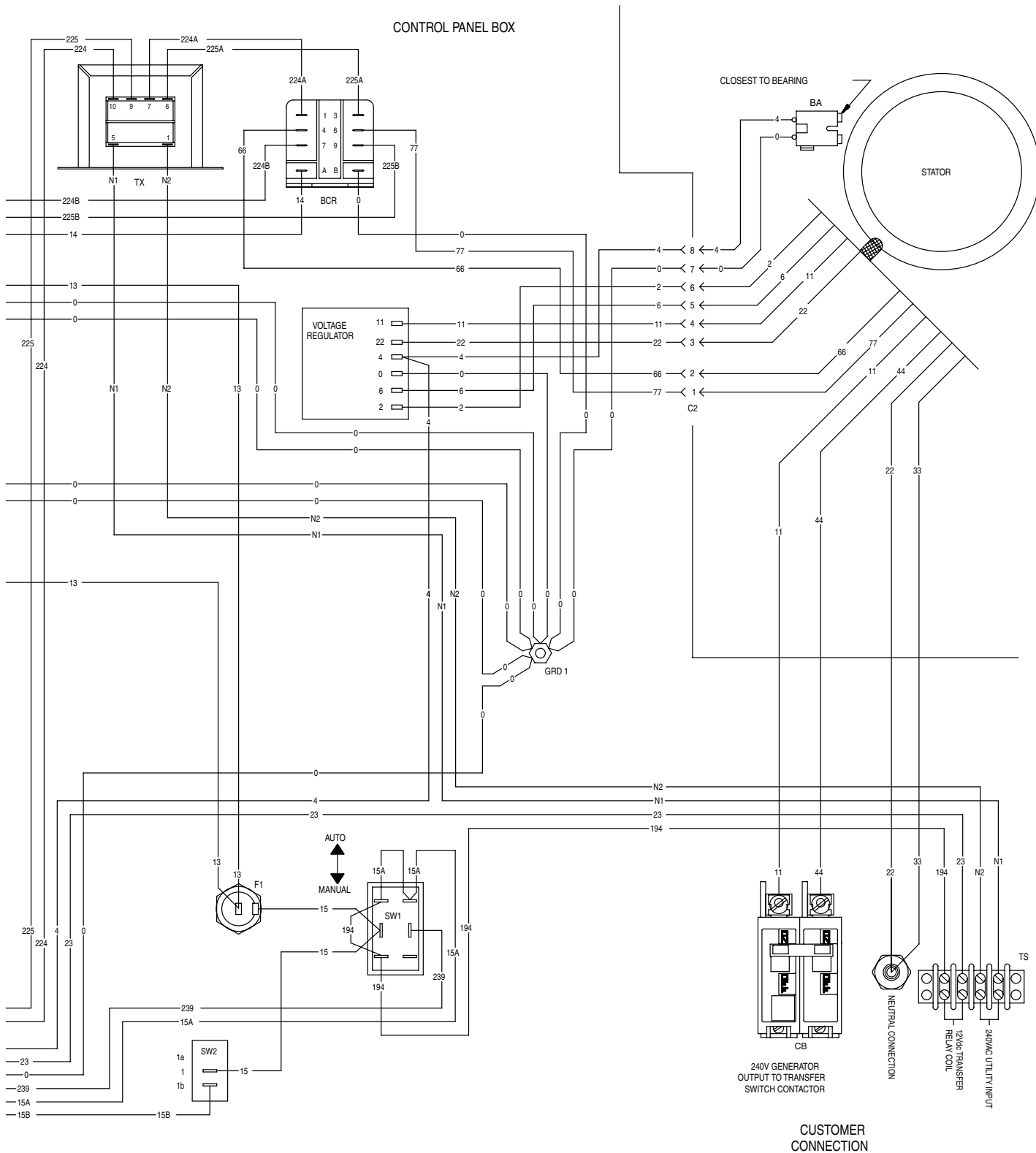
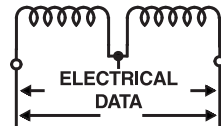

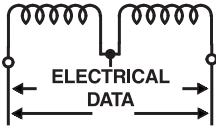

**Section 8 – Electrical Data**

**Air-cooled Generators  
Electrical Schematic – 7kW, Single Cylinder – Drawing No. 0F7821**

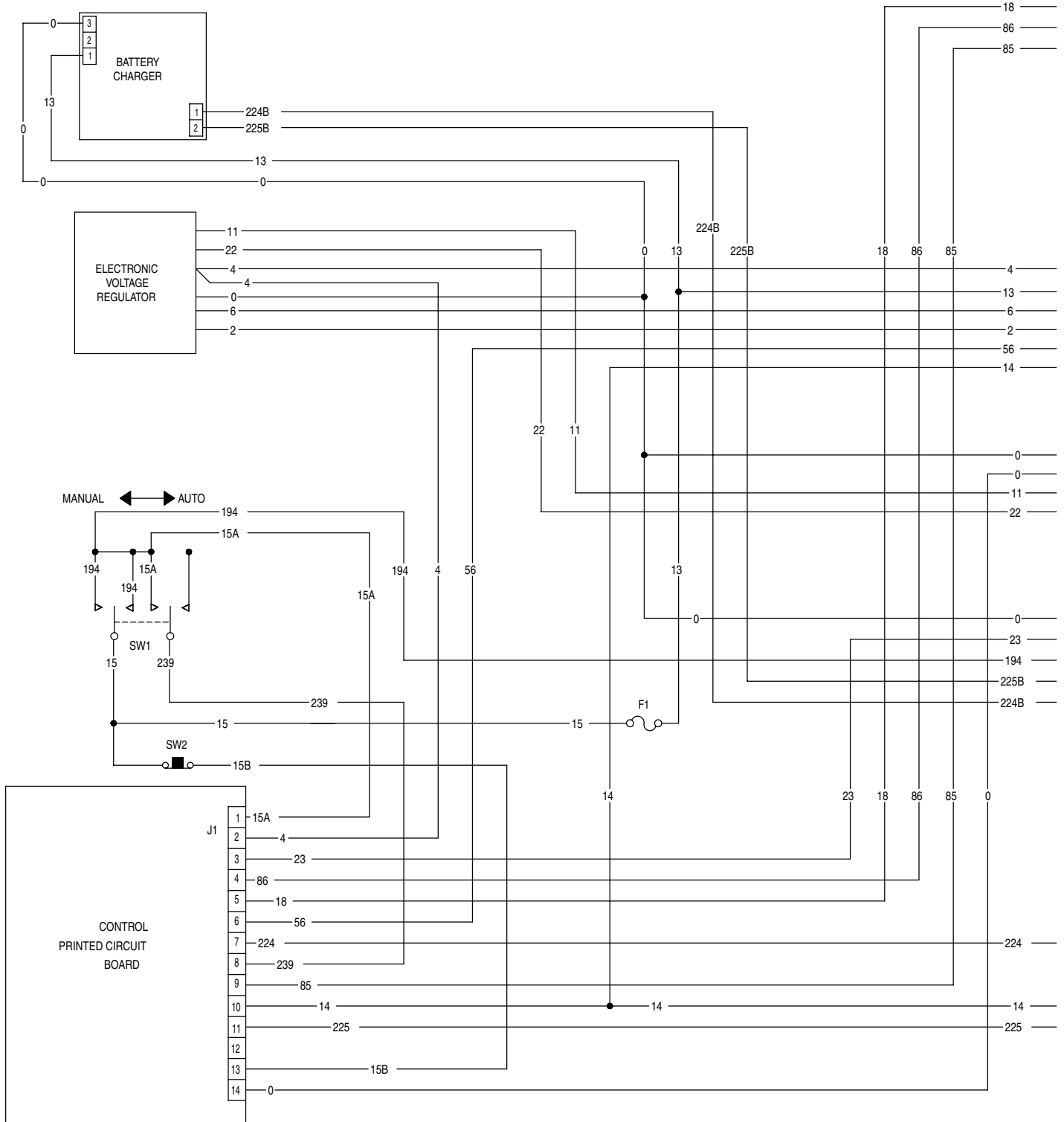



## Section 8 – Electrical Data

### Air-cooled Generators

#### Electrical Schematic – 7kW, Single Cylinder – Drawing No. 0F7821

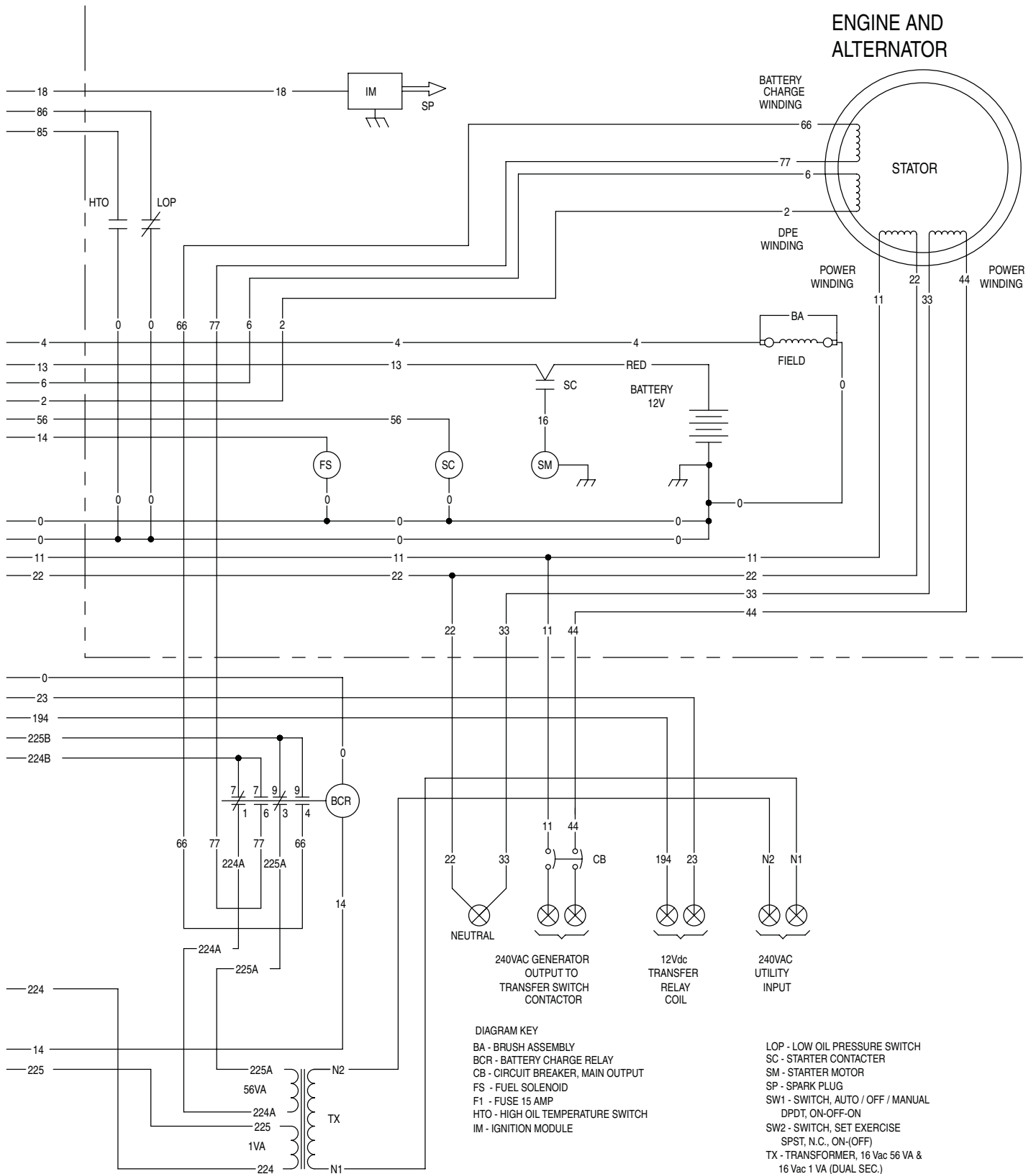
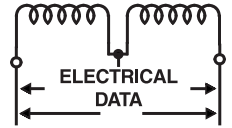

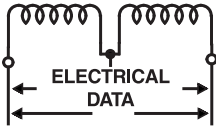

**Section 8 – Electrical Data**

**Air-cooled Generators**

**Wiring Diagram – 8, 10, 12 and 16 Circuit Load Center – Drawing No. 0F9070-A**

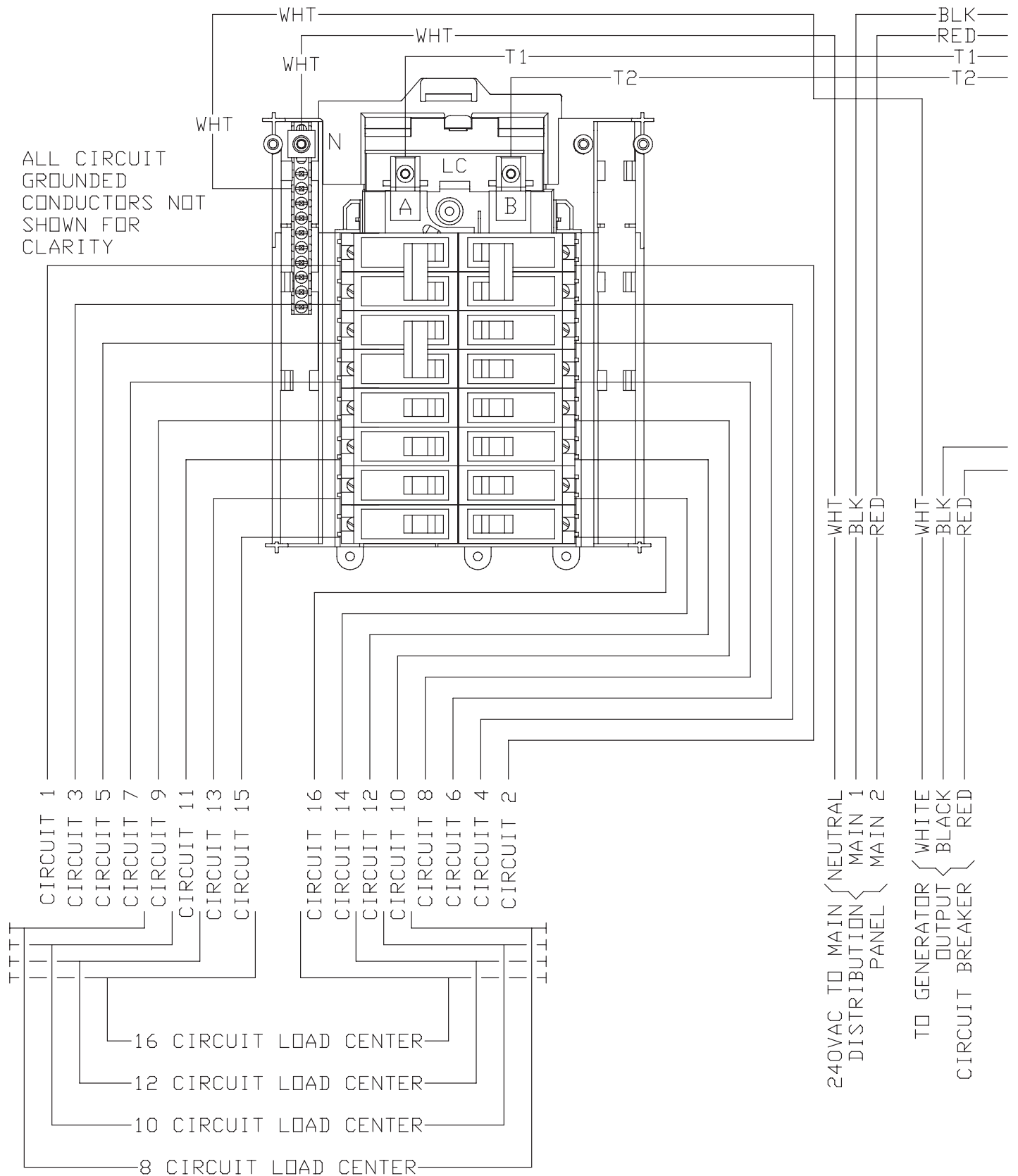

Section 8 – Electrical Data

Air-cooled Generators

Wiring Diagram – 8, 10, 12 and 16 Circuit Load Center – Drawing No. 0F9070-A

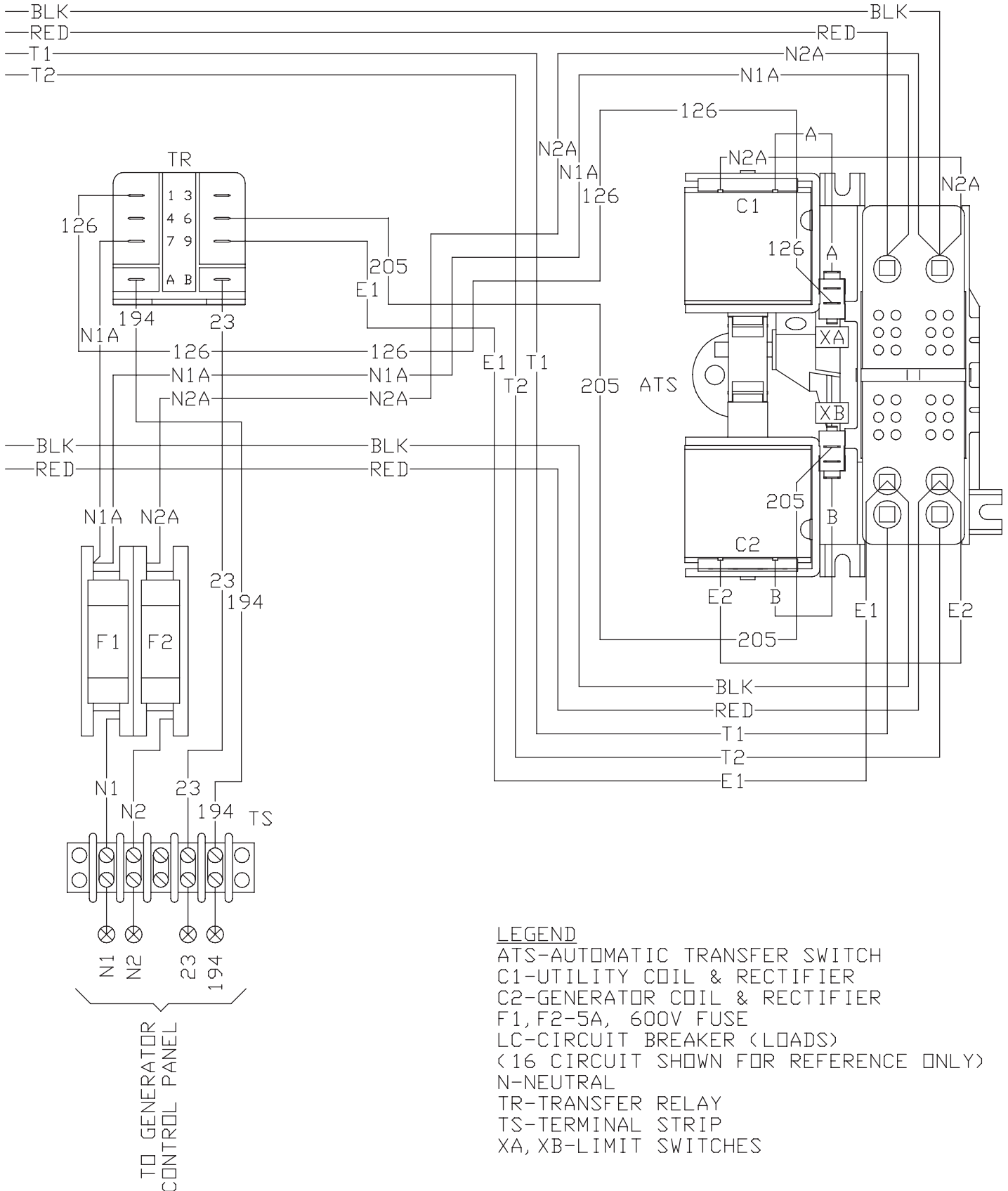
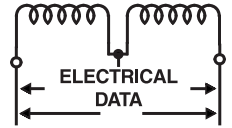

LEGEND

- ATS-AUTOMATIC TRANSFER SWITCH
- C1-UTILITY COIL & RECTIFIER
- C2-GENERATOR COIL & RECTIFIER
- F1, F2-5A, 600V FUSE
- LC-CIRCUIT BREAKER (LOADS)  
(16 CIRCUIT SHOWN FOR REFERENCE ONLY)
- N-NEUTRAL
- TR-TRANSFER RELAY
- TS-TERMINAL STRIP
- XA, XB-LIMIT SWITCHES



## Section 9 – Exploded Views and Parts Lists

### Air-cooled Generators Enclosure – Drawing No. 0F9431-D

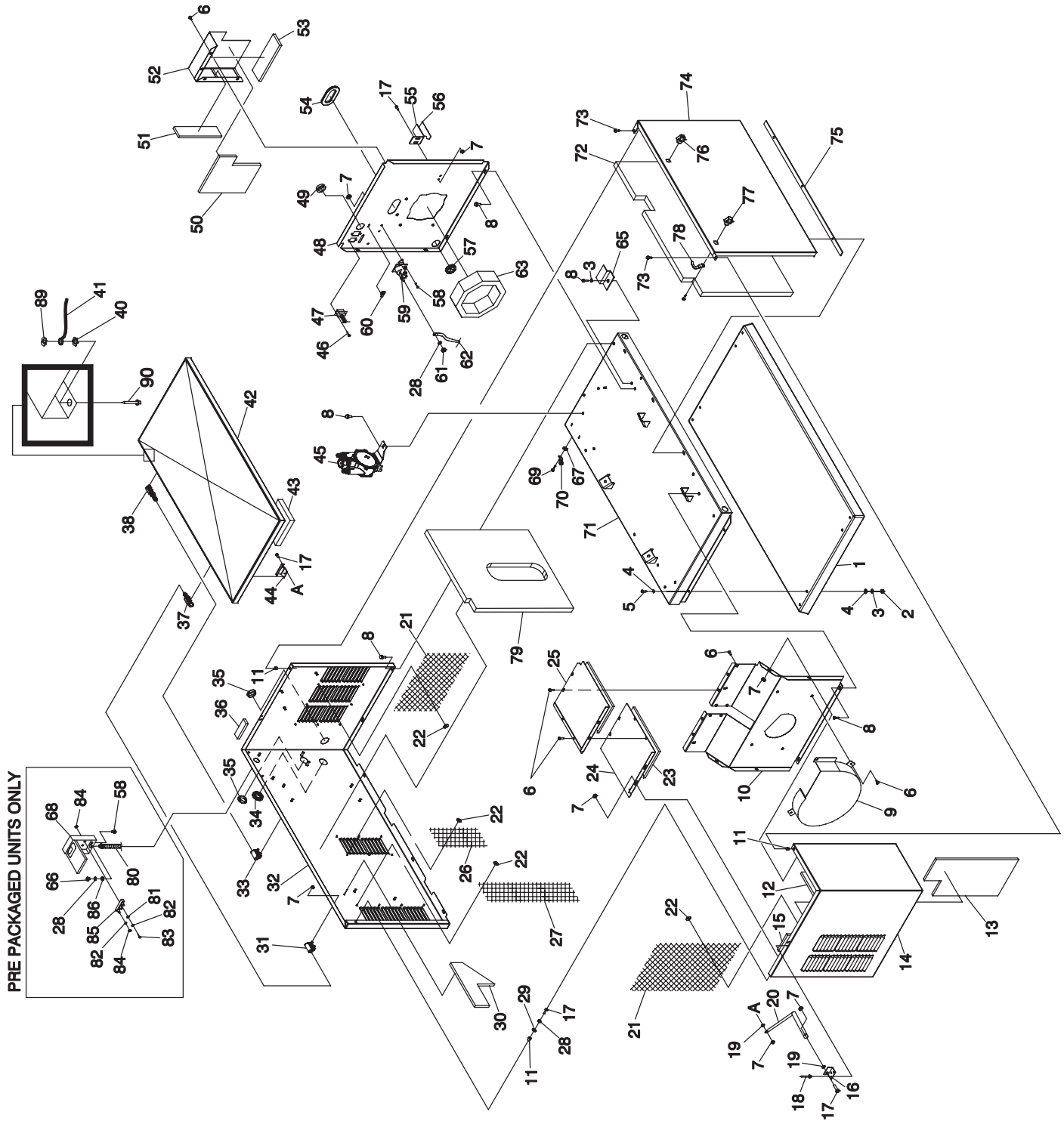

#### SHEET METAL PAINT/MATERIAL CODE LEGEND

The following exploded views contain part numbers of various sheet metal components. Only the base part number is listed. When ordering sheet metal, the correct color and material information must be included as a suffix at the end of the part number as shown below.

Material	Color	Example:	Desc.	Part No.	Material	Color	Order As"
S = Steel	N = Tan		Roof	0F6522	S = Steel	N = Tan	0F6522SN
A = Aluminum	G = Gray		Door	0F6555	A = Aluminum	G = Gray	0F6555AG
	B = Black		Divider	0F6558	S = Steel	B = Black	0F6558SB

## Section 9 – Exploded Views and Parts Lists

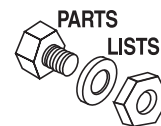

### Air-cooled Generators Enclosure – Drawing No. 0F9431-D

ITEM	PART NO.	QTY.	DESCRIPTION	ITEM	PART NO.	QTY.	DESCRIPTION
1	0F9653	1	PAD, 24 X 48" WITH MOUNTING HOLES	47	0F5438	1	HARNESS, ENGINE (7KW)
2	045771	4	NUT HEX M8-1.25		0F5434	1	HARNESS ENG V-T HSB
3	022129	4	WASHER LOCK 5/16	48	0F8263	1	PANEL, ENGINE DIVIDER (7KW)
	022129	5	WASHER LOCK 5/16 (7KW)		0F7886	1	PANEL, ENGINE DIVIDER (10KW)
4	022145	8	WASHER FLAT 5/16		0F7885	1	PANEL, ENGINE DIVIDER
5	043107	4	SCREW HHC M8-1.25 X 25	49	023484H	1	BUSHING SNAP SB-1500-18
6	090388	15	SCREW TAPTITE M6-1.0 X 12	50	0D3058A	1	FOAM, FRONT INTAKE BAFFLE (7KW)
7	0D3700	24	NUT, LOCKING FLANGE M6-1.0		0E4245	1	FOAM, FRONT INTAKE BAFFLE
	0D3700*	14	NUT, LOCKING FLANGE M6-1.0	51	0D3058C	1	FOAM, BACK INTAKE BAFFLE (7KW)
	022097*	10	WASHER LOCK M6-1/4	52	0D1605A	1	BAFFLE, INTAKE (7KW)
	022473*	10	WASHER FLAT 1/4-M6 ZINC		0F7798	1	BAFFLE, INTAKE
	049813*	10	NUT HEX M6 X 1.0	53	0F8380	1	FOAM, TOP INTAKE BAFFLE
8	0D4662	14	SCREW HHTR 5/16-18 X 3/4" (7KW)	54	0D3472	1	GROMMET OVAL 31.75 X 50.8
	0D4662	13	SCREW HHTR 5/16-18 X 3/4"	55	0C8285	1	BRACKET, BATTERY SUPPORT
9	0F8871	1	SCROLL, FAN (7KW, 10KW)	56	0D3167	1	GASKET, BATTERY SUPPORT BRACKET
	0F8080	1	SCROLL, FAN	57	0E1330	1	GROMMET, 38.1 DIA. CROSS SLIT
10	0F8246	1	PANEL, ALTERNATOR DIVIDER (7KW)	58	043116	3	SCREW HHC, M6-1.0 X 12 G8.8(7KW)
	0F8915	1	PANEL, ALTERNATOR DIVIDER (10KW)		043116	1	SCREW HHC M6-1.0 X 12 G8.8
	0F6558	1	PANEL, ALTERNATOR DIVIDER	59	086729	1	CONTACTOR, STARTER (7KW)
11	092120	4	NUT LOCK TRIC M6 X 1.0	60	0F8039	1	MOUNTING CLIP
12	0F7825	1	FOAM, MUFFLER BOX FRONT	61	022127	1	NUT HEX 1/4-20 (7KW)
13	0F7824	1	FOAM, MUFFLER BOX END	62	0388040AJ0	1	CABLE, #6 RED BATTERY 38.5"
14	0F6549	1	ENCLOSURE, EXHAUST SIDE	63	0F8847	1	GASKET, FRONT DIVIDER
15	0F7824A	1	FOAM, MUFFLER BOX END		0F8434	1	GASKET, FRONT DIVIDER (10KW)
16	0D1840	2	BRACKET, BOTTOM SUPPORT	64	0F9968	1	FUEL LINE, 1/2" OUTDOOR (NOT SHOWN)
17	047411	6	SCREW HHC M6-1.0 X 16 G8.8 (7KW)	65	0C2937	1	BRACKET, BATTERY HOLD DOWN (7KW)
	047411	8	SCREW HHC M6-1.0 X 16 G8.8	66	049813	1	NUT HEX M6-1.0 G8
18	0F0710	12	RIVET POP 0.125" X 0.337"	67	0A1658	1	LOCK WASHER SPECIAL 1/4
19	0A2115	4	WASHER NYLON M6-1/4"	68	0G0617	1	EXTERNAL CONNECTION BOX
20	0C6735	2	SUPPORT, ROOF FOLDING	69	092079	1	SCREW TAPTITE M6-1.0 X 25 BP
21	0D2979D	2	CLOTH HARDWARE 266.7mm X 387.4mm	70	055414	1	LUG SLDLSS #2-#8 X 17/64 CU
22	0D7176	34	WASHER, SELF LOCKING	71	0F8234	1	ASSEMBLY, ENCLOSURE BASE (7KW)
23	0F7827	2	FOAM, EXHAUST ENCLOSURE COVER		0F7711	1	ASSEMBLY, ENCLOSURE BASE
24	0F6570	1	COVER, BACK EXHAUST ENCLOSURE	72	0F8257	1	FOAM, FRONT ENCLOSURE
25	0F6571	1	COVER, FRONT EXHAUST ENCLOSURE	73	0C3906	2	SELF-ALIGN SCREW M6 HH
26	0D2979B	1	CLOTH, HARDWARE 266.7mm X 146mm	74	0F6555	1	ENCLOSURE, FRONT
27	0D2979C	1	CLOTH, HARDWARE 543mm X 146mm	75	0F8555	1	GASKET, DOOR SEAL
28	022097	4	WASHER LOCK M6-1/4 (7KW)	76	0D3037	1	LATCH, QUARTER TURN LOCKING
	022097	3	WASHER LOCK M6-1/4	77	0D3037A	1	LATCH, QUARTER TURN NON-LOCKING
29	022473	2	WASHER FLAT M6-1/4	78	0F9143	2	PAWL, DOOR
30	0F7826	1	FOAM, MUFFLER BOX BACK	79	0F8261	1	FOAM, BACK ENCLOSURE
31	0F0165A	1	HINGE TYPE B WITH STUDS, SOCKET	80	0F5440	1	HARNESS GENERATOR TO EXTERNAL CONNECTION BOX (7KW)
32	0F6550	1	ENCLOSURE, SIDE & BACK		0F9328	1	HARNESS GENERATOR TO EXTERNAL CONNECTION BOX (10KW)
33	0F0164A	1	HINGE TYPE A WITH STUDS, SOCKET		0F5478	1	HARNESS GENERATOR TO EXTERNAL CONNECTION BOX
34	0E1330A	1	GROMMET, 38.1 CROSS SLIT WITH HOLE	81	051713	2	WASHER FLAT M5
35	021267A	2	PLUG PLASTIC 1.5 BLIND GROMMET	82	022152	5	WASHER LOCK #10
36	0E5968	11	GASKET, EXTRUDED TRIM	83	036937	2	SCREW PPHM#10-32 X 1
37	0F0165	1	HINGE TYPE B WITH STUDS, PIN	84	022158	5	NUT HEX #10-32
38	0F0164	1	HINGE TYPE A WITH STUDS, PIN	85	0C8911	1	POWER BLOCK
40	0A8475	1	L/WASH SPECIAL #10	86	026850	1	WASHER SHAKEPROOF EXT 1/4 STEEL
41	0G0400	1	WIRE ASSEMBLY, GROUND	89	0G3540	1	WASHER FLAT .125ID X .375OD
42	0F6552	1	ENCLOSURE, ROOF	90	0G3539	1	RIVET POP .122 X 0.465 STEEL
43	0F9379	1	FOAM, ROOF ENCLOSURE				
44	0D1839	2	BRACKET, TOP SUPPORT				
45	0F8210	1	REGULATOR ASSEMBLY (7KW)				
	0F8209	1	REGULATOR ASSEMBLY (10KW)				
	0F9078	1	REGULATOR ASSEMBLY				
46	0F5458	4	SCREW PLASTITE HI-LOW #10 X 3/8				

\*ITEM 7 FOR MODELS WITH ALUMINUM ENCLOSURE

Section 9 – Exploded Views and Parts Lists

Air-cooled Generators  
Control Panel – Drawing No. 0F9695-C

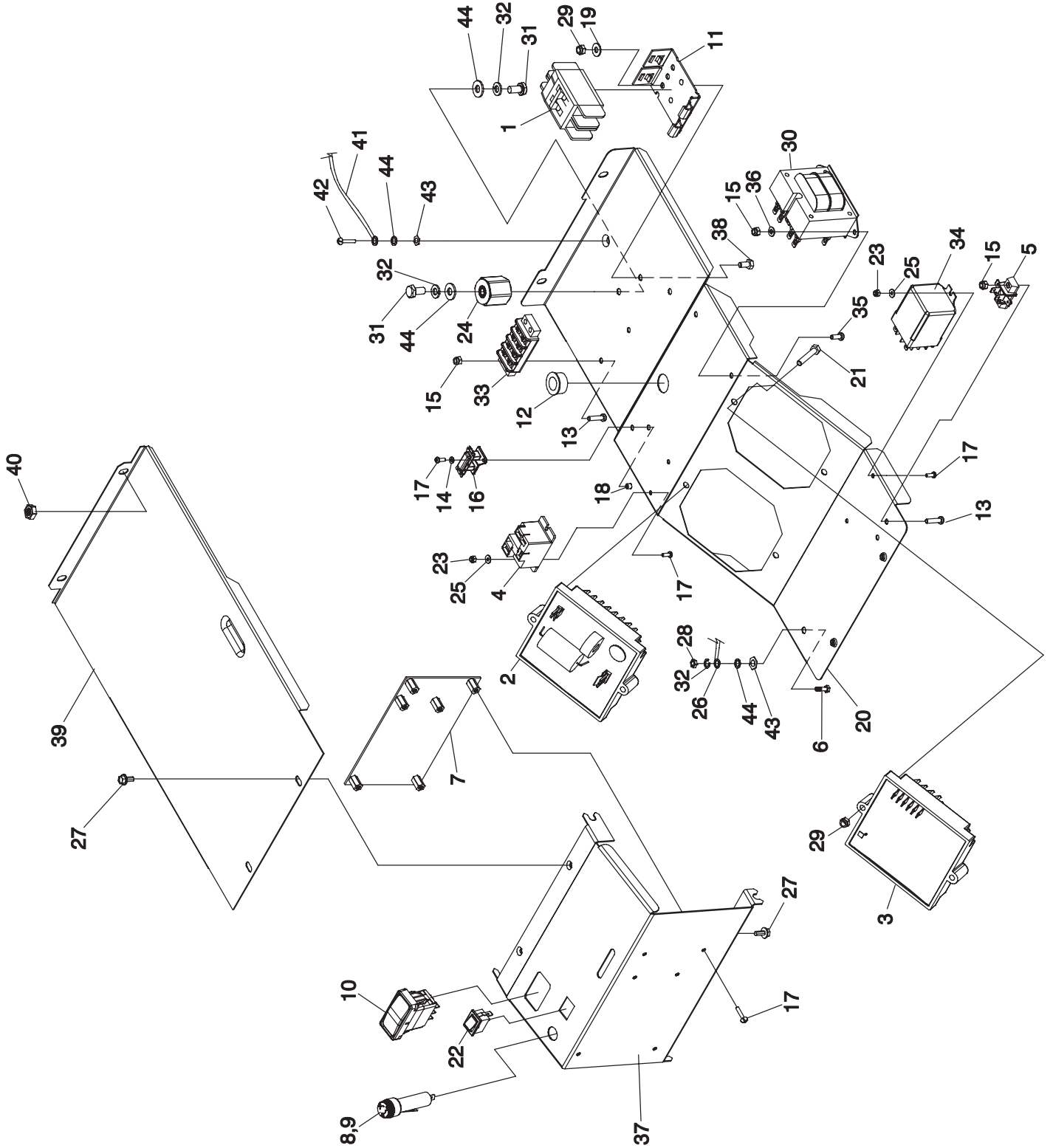

## Section 9 – Exploded Views and Parts Lists

### Air-cooled Generators Control Panel – Drawing No. 0F9695-C

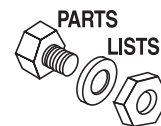

ITEM	PART NO.	QTY.	DESCRIPTION	ITEM	PART NO.	QTY.	DESCRIPTION
1	0E7886A	1	CIRCUIT BREAKER 30A X 2P 240V (7KW)	0D9784	2	NUT HEX LOCK M3-0.5 NYLON INSERT (7KW)	
	0E7886D	1	CIRCUIT BREAKER 45A X 2P 240V (10KW)	24	0D8502	1	NEUTRAL BLOCK
	0E7886K	1	CIRCUIT BREAKER 55A X 2P 240V (13KW)	25	031879	4	WASHER FLAT #4
	0E7886J	1	CIRCUIT BREAKER 65A X 2P 240V (16KW)	26	0F5433	2	WASHER FLAT #4 (7KW)
2	0A1801	1	ASSEMBLY, BATTERY CHARGER ENGINE		0F5437	1	HARNESS, CONTROL PANEL WIRE (NOT SHOWN)
3	0F9719	1	ASSEMBLY, POTTED REGULATOR		0F5437	1	HARNESS, CONTROL PANEL WIRE (NOT SHOWN) (7KW)
4	0C2174	1	RELAY, 12V 25A SPST (NON 7KW)	27	074908	4	SCREW HHTT, M5-0.8 x 10 BP
5	075210A	1	BLOCK TERMINAL 1 POSITION	28	049813	1	NUT HEX M6-1.0
6	038750	1	SCREW HHC M6-1.0 x 30mm	29	082025	6	NUT HEX LOCK M5-0.8 NYLON INSERT
7	0F8992	1	ASSEMBLY, HOME STANDBY CONTROLLER	30	0G0627	1	XFMR 240/16V 1VA&56VA W/PTC
	0F1504	1	ASSEMBLY, HOME STANDBY CONTROLLER (7KW)	31	022507	2	SCREW HHC 1/4"-20 x 1/2"
8	032300	1	HOLDER, FUSE	32	022097	3	WASHER LOCK M6-1/4"
9	022676	1	FUSE, 15 AMP X AGC15	33	046689	1	TERMINAL STRIP 4 POSITION
10	0E4494	1	SWITCH, ROCKER DPDT ON-OFF-ON	34	063617	1	RELAY PANEL 12VDC DPDT 10A 240VAC
11	0E7890	1	CIRCUIT BREAKER MOUNTING BRACKET	35	075475	2	SCREW PPHM M4-0.7 x 10mm
12	023484E	1	SNAP BUSHING	36	043180	2	WASHER FLAT M4
13	075476	4	SCREW PPHM M4-0.7 x 16mm	37	0F8041	1	COVER, CONTROL PANEL COMPONENT
14	043182	2	M3 LOCK WASHER (NON 7KW)		0F9283	1	COVER, CONTROL PANEL COMPONENT (7KW)
15	0E6480	6	NUT HEX LOCK M4-0.7 NYLON INSERT	38	045770	2	SCREW HHC M5-0.8 x10mm
16	0D4804A	1	CURRENT TRANSFORMER, IDLE CONTROL (NON 7KW)	39	0E7866	1	COVER, CONTROL PANEL
17	0C1085	12	SCREW PPHM M3-0.5 x 8mm		0E7867	1	COVER, CONTROL PANEL (7KW)
	0C1085	8	SCREW PPHM M3-0.5 x 8mm (7KW)	40	0D3700	8	NUT FLANGE M6-1.0 NYLOK
18	058000H	2	M3-0.5 TRIC NUT (NON 7KW)		022097*	8	WASHER LOCK M6-1/4
19	023897	2	WASHER FLAT #10		022473*	8	WASHER FLAT 1/4-M6
20	0F8040	1	CONTROL, PANEL BOTTOM		049813*	8	NUT HEX M6 X 1.0
	0F9282	1	CONTROL, PANEL BOTTOM (7KW)	41	0G0400	1	WIRE ASSEMBLY, GROUND
21	075235	4	SCREW HHC M5-0.8 x 30mm	42	0E2874	1	SCREW HHTR 1/4"-20 X 3/4"
22	0E3928	1	SWITCH, SPST	43	0A1658	2	WASHER LOCK SPECIAL 1/4"
23	0D9784	4	NUT HEX LOCK M3-0.5 NYLON INSERT	44	022473	4	WASHER FLAT 1/4"-M6

\*ITEM 40 FOR MODELS WITH ALUMINUM ENCLOSURE

Section 9 – Exploded Views and Parts Lists

Air-cooled Generators  
Transfer Switch Assembly – Drawing No. 0F9774-B

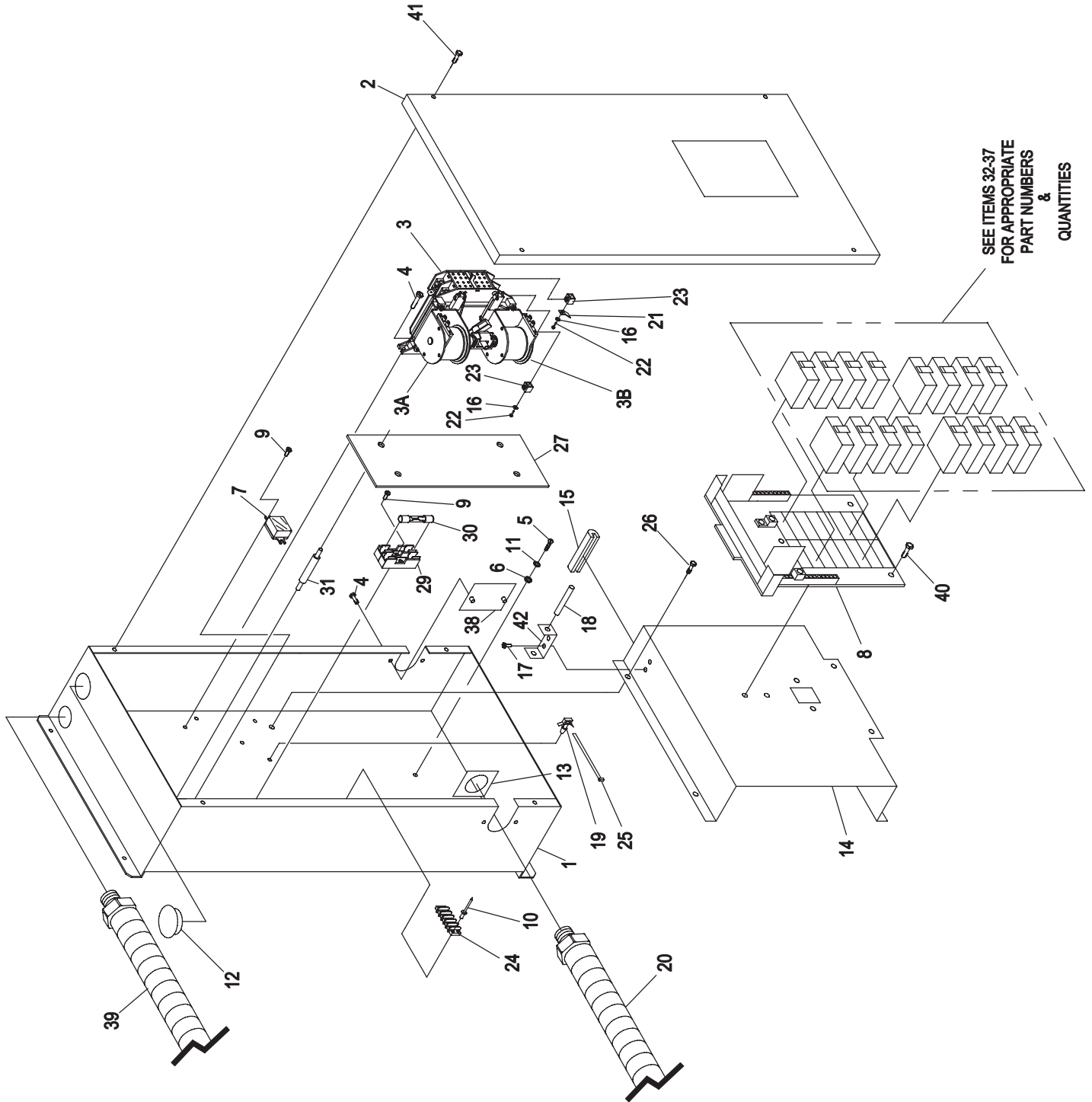



## Section 9 – Exploded Views and Parts Lists

### Air-cooled Generators Transfer Switch Assembly – Drawing No. 0F9774-B

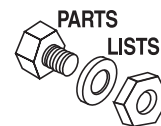

ITEM	PART NO.	QTY.	DESCRIPTION	ITEM	PART NO.	QTY.	DESCRIPTION
1	0F8278	1	BOX LOAD CENTER	21	074138	2	LUG QUICK DISCONNECT NI-S 10X45 DEG BRASS / TIN
2	0D4800	1	COVER, 8 CIRCUIT LOAD CENTER	22	036933	6	SCREW PPHM #10-32 X 3/8"
	0F5211	1	COVER, 10 CIRCUIT LOAD CENTER	23	077033	6	LUG SLDLSS 1/0-#14X9/16 AL/CU
	0D3092	1	COVER, 12 CIRCUIT LOAD CENTER	24	048850	1	BLOCK TERMINAL 20A 5 X 6 X 1100V
	0F8312	1	COVER, 16 CIRCUIT LOAD CENTER	25	028739	4	TIE WRAP 3.9" X .10"
3	0C2237	1	TRANSFER SWITCH HOME STANDBY 100A 2P 250V	26	0A2110	4	SCREW SWAGE 1/4-20 X 1/2" ZINC
3A	077220	1	COIL UTILITY	27	0D3191	1	COVER, RELAY & TERMINAL BLOCK
3B	077220A	1	COIL STANDBY	28	0D3088	1	WIRE HARNESS, LOAD CENTER (NOT SHOWN)
3C	082574	1	INSULATOR-SIDEWALL (NOT SHOWN)	29	073591	2	FUSE HOLDER
3D	084464	1	LIMIT SWITCH OPERATION (NOT SHOWN)	30	073590A	2	FUSE 5A
4	074908	6	SCREW HHTT M5-0.8 X 10	31	040213B	4	SUPPORT SNAP-IN 1-3/8"
5	024912	1	SCREW HHTT 1/4-20 X 5/8				<u>8 10 12 16 CIR.</u>
6	0A1658	1	LOCK WASHER, SPECIAL-1/4"	32	0E7888	A/R	CIR. BREAKER 20A 2P 1 1
7	063617	1	RELAY PANEL 12VDC DPDT 10A@240VAC	33	0E7888A	A/R	CIR. BREAKER 30A 2P 1 1 1
8	0E7889A	1	8 CIRCUIT LOAD CENTER	34	0E7888B	A/R	CIR. BREAKER 15A 1P 5 3 5 5
	0E7889	1	12 CIRCUIT LOAD CENTER (ALSO USED FOR 10 CIRCUIT)	35	0E7888C	A/R	CIR. BREAKER 20A 1P 1 3 3 5
	0F9213	1	16 CIRCUIT LOAD CENTER	36	0E7888D	A/R	CIR. BREAKER 40A 2P 1 1
9	0A1495	4	SCREW HHTT M4-0.7 X 10	37	0E7888E	A/R	CIR. BREAKER 50A 2P 1
10	0A1661	2	RIVET POP .156" X .675"	38	0D3320	1	COVER - HARNESS ENTRY
11	022473	1	WASHER FLAT 1/4-M6 ZINC	39	0F5439	1	HARNESS, 8 CIRCUIT LOAD CENTER TO EXT CONN BOX
12	081108	1	PLUG PLASTIC		0F9327	1	HARNESS, 10 CIRCUIT LOAD CENTER TO EXT CONN BOX
13	0D4684	1	HARNESS ADAPTER PLATE		0F6720	1	HARNESS, 12 CIRCUIT LOAD CENTER TO EXT CONN BOX
	0D4684A	1	8 CIRCUIT HARNESS ADAPTER PLATE		0F6720	1	HARNESS, 16 CIRCUIT LOAD CENTER TO EXT CONN BOX
14	0F8279	1	SUBPLATE, LOAD CENTER	40	075475	2	SCREW PPHM M4-0.7 X 10
15	0F4790	10.5"	U-CHANNEL	41	0A7215	4	SCREW SW 1/4"-20 X 5/8" WITH WASHER
16	022152	6	WASHER LOCK #10	42	0E6193	1	BRACKET, ARM EXTENDER
17	064526	2	SCREW HWHS #6-25 X 3/8"				
18	0E6155	1	ARM EXTENDER PIN				
19	063378	4	HOLDER CABLE TIE				
20	0G0979	1	HARNESS, 8 CIRCUIT LOAD CENTER TO MAIN PANEL				
	0G0980	1	HARNESS, 10 CIRCUIT LOAD CENTER TO MAIN PANEL				
	0G0981	1	HARNESS, 12 CIRCUIT LOAD CENTER TO MAIN PANEL				
	0G0982	1	HARNESS, 16 CIRCUIT LOAD CENTER TO MAIN PANEL				

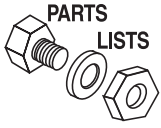

## Section 9 – Exploded Views and Parts Lists

### Air-cooled Generators

13 & 16kW, GT-990 Engine – Drawing No. 0F9430-K - Part 1

59	2, 5, 15, 16, 28, 35, 42, 58, 86
60	4, 5, 6
61	7, 42, 43, 44, 45, 46, 47, 48, 49, 50, 51, 52, 53, 54, 57, 58
62	42, 43, 44, 45, 46, 47, 48, 49, 50, 51, 52, 53, 54, 56, 57, 58
63	23, 24, 25

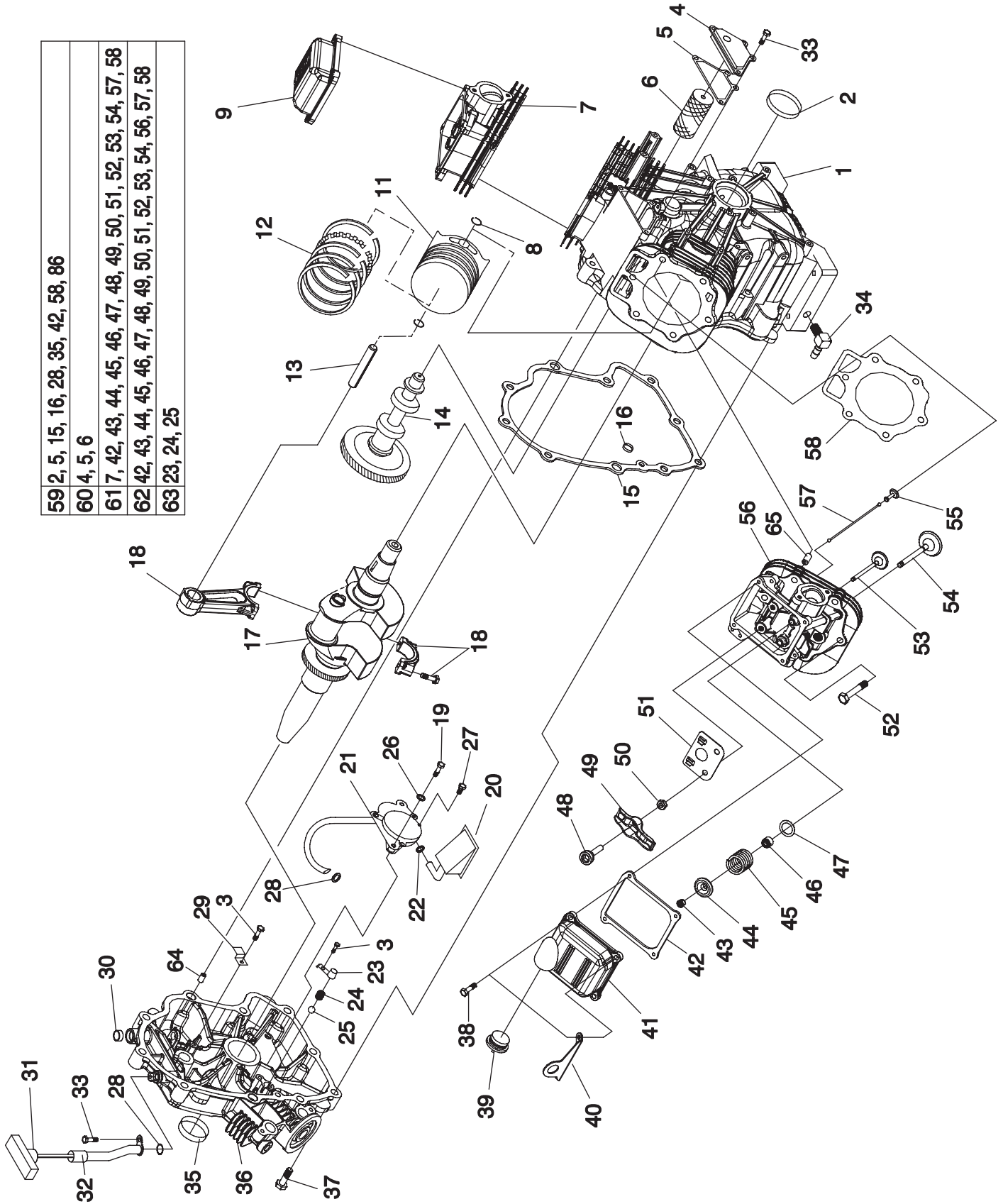

## Section 9 – Exploded Views and Parts Lists

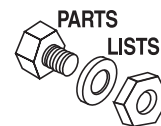

### Air-cooled Generators 13 & 16kW, GT-990 Engine – Drawing No. 0F9430-K - Part 1

ITEM	PART NO.	QTY.	DESCRIPTION	ITEM	PART NO.	QTY.	DESCRIPTION
1	0C5729	1	ASSEMBLY, CRANKCASE HOUSING WITH SLEEVE	34	043790	1	BARBED ELBOW 90 3/8NPT X 3/8
2	0E9843	1	SEAL, 38 I.D. CRANKSHAFT	35	0E9842	1	SEAL, 42 I.D. CRANKSHAFT
3	090388	3	SCREW, TAPTITE M6-1.0 X 12 YC	36	0C5731	1	ASSEMBLY, HOUSING COVER WITH SLEEVE
4	0C5372	1	ASSEMBLY, BREATHER	37	0C3006	10	SCREW, HHFC M10-1.5 X 55
5	0C3005	1	GASKET, BREATHER COVER	38	080318	8	SCREW HHFC M6-1.0 X 25
6	0E3372B	1	SEPARATOR, OIL BREATHER	39	093064	1	ASSEMBLY, OIL FILL CAP
7	0D8067A	1	ASSEMBLY, HEAD #1 G&S	40	0G1839	2	LIFT HOOK GT990/760
8	071983	4	RETAINER, PISTON PIN 20	41	0D2723D	1	ROCKER, COVER WITH OIL FILL
9	0C2981F	1	ROCKER, COVER NO OIL FILL	42	0C2979	2	GASKET, VALVE COVER
11	0E2985	2	PISTON, HC	43	086515	8	KEEPER, VALVE SPRING
12	021533	2	SET, PISTON RING 90MM	44	0D2274	4	RETAINER, VALVE SPRING
13	0E1466	2	PIN PISTON	45	0D3867	4	SPRING, VALVE
14	0D4041	1	ASSEMBLY, CAMSHAFT & GEAR	46	078672	2	SEAL, VALVE STEM D7
15	0C2977	1	GASKET, CRANK CASE	47	0C5371	4	WASHER, VALVE SPRING
16	0C5943	1	SEAL, OIL PASSAGE	48	072694	4	STUD, ROCKER ARM PIVOT
17	0G0140E	1	ASSEMBLY, CRANKSHAFT HORIZONTAL DIRECT DRIVE	49	0D5313	4	ROCKER ARM
18	0E3223	2	ASSEMBLY, CONNECTING ROD	50	0D3998	4	NUT HEX M8-1.0 G8 YEL CHR
19	0D2157	2	SCREW SHC M6-1.0 X 50 G8.8	51	0D6024	2	PLATE, PUSH ROD GUIDE
20	0E6098	1	SCREEN, OIL PICKUP	52	0C2976	12	SCREW HHFC M8-1.25 X 65
21	0D4123A	1	ASSEMBLY, OIL PUMP	53	086516	2	VALVE, EXHAUST
22	0E8152	1	O-RING .49 ID X .07 THICK	54	0C2229	2	VALVE, INTAKE
23	0C3011	2	COVER, OIL RELIEF	55	083897	4	TAPPET, SOLID
24	0C3009	2	SPRING, OIL RELIEF	56	0D8067B	1	ASSEMBLY, HEAD #2 G&S
25	0C3010	2	BALL, 1/2D OIL RELIEF	57	0D9853D	4	PUSHROD, 147
26	093873	2	WASHER, LOCK RIB M6	58	0C2978	2	GASKET, HEAD
27	0F5458	1	SCREW, PLASTITE HI-LOW #10	59	0D4010	1	KIT GASKET
28	0C3027	3	O-RING, 3/8" X 1/2"	60	0D4012	1	KIT BREATHER ASSEMBLY
29	0C5998	1	CLAMP, OIL TUBE	61	0D8675A	1	KIT HEAD ASSEMBLY CYLINDER 1
30	0D4497	1	PLUG-CRANKCASE	62	0D8675B	1	KIT HEAD ASSEMBLY CYLINDER 2
31	0F2664C	1	ASSEMBLY, DIPSTICK WITH HANDLE	63	0D4015	1	KIT OIL RELIEF
32	0C5305	1	TUBE, DIPSTICK	64	078699C	2	SLEEVE DOWEL PIN 14 DIA.
33	0D6147	7	SCREW HHFC M6-1.0 X 10mm	65	078699B	4	SLEEVE DOWEL PIN 12 DIA.

Section 9 – Exploded Views and Parts Lists

Air-cooled Generators

13 & 16kW, GT-990 Engine – Drawing No. 0F9430-K - Part 2

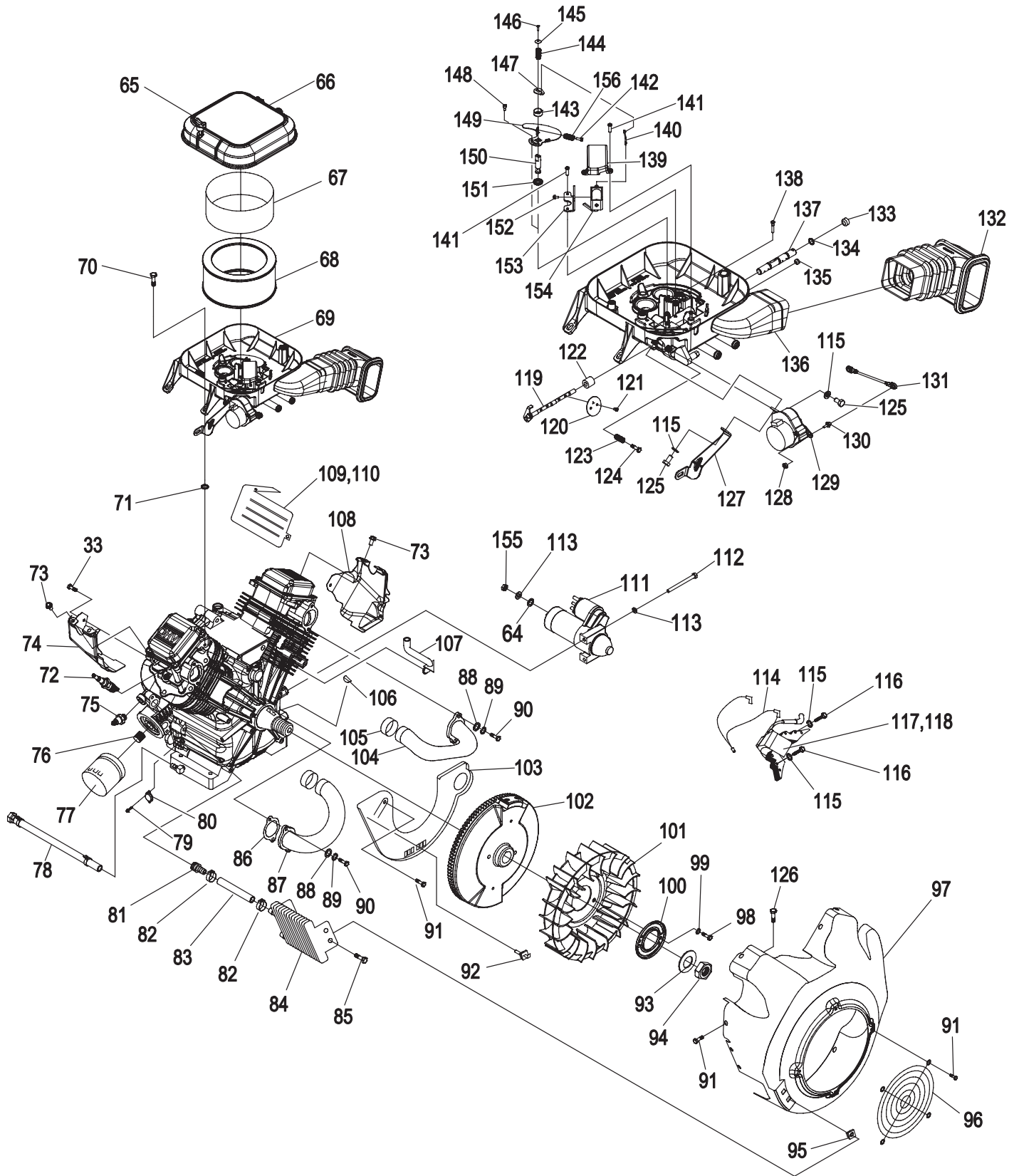

## Section 9 – Exploded Views and Parts Lists

### Air-cooled Generators

#### 13 & 16kW, GT-990 Engine – Drawing No. 0F9430-K - Part 2

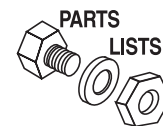

ITEM	PART NO.	QTY.	DESCRIPTION	ITEM	PART NO.	QTY.	DESCRIPTION
64	022145	1	WASHER FLAT M8 – 5/16	110	0D1143	1	WRAPPER, UPPER CYLINDER 2
65	0C5136A	2	KNOB, AIR CLEANER	111	0E9323	1	STARTER MOTOR HEAR REDUCED 1KW
66	0C3024	1	COVER, AIRBOX NG/LP	112	061906	2	SCREW HHC M8 – 1.25 X 85 G8.8
67	0C3040	1	PRE-CLEANER,	113	022129	3	WASHER LOCK M8 – 5/16
68	0C8127	1	ELEMENT, AIR CLEANER	114	0F1177	1	ASSEMBLY, GROUND WIRE
69	0F9255	1	ASSEMBLY, MIXER/AIRBOX 990	115	022097	6	WASHER LOCK M6 – 1/4
70	0E9582	4	SCREW SHLDR(8MM) M6-1.0 X 21	116	0G3111	4	SCREW TAPTITE M6 – 1.0 X 25 ZINC
71	0D4417	4	WASHER,RUBBER 1/4" X 1/8" THICK	117	0G0798A	1	ASSY, IGN COIL W/DIODE, CYLINDER 1
72	0E7585A	2	SPARKPLUG, RC14YC GAP: 0.040"	118	0G0798B	1	ASSY, IGN COIL W/DIODE, CYLINDER 2
73	0E6043	2	SCREW TAPTITE M5 – 0.8 X 8	119	0E9568	1	ASSY, THROTTLE SHAFT
74	0D1142A	1	WRAPPER, LOWER CYLINDER 2	120	0E9565	2	THROTTLE VALVE
75	0C3025	1	SWITCH, OIL PRESS	121	074027	4	SCREW PPHM M3 – 0.5 X 5
76	0C7292	1	NIPPLE, 3/4"-16 UNF	122	0C3044	1	COVER, DUST, MIX/AIRBOX
77	070185B	1	OIL FILTER	123	0C4756	1	SPRING, IDLE ADJUST
78	0D3083	1	ASSY, OIL DRAIN HOSE	124	075477	1	SCREW PPHM M5 – 0.58 X 20
79	0F2094	2	SCREW M3 – 0.5 X 6 SEMS	125	043116	2	SCREW HHC M6 – 1.0 X 12
80	094090	1	SWITCH, THERMAL 293F	126	0E1644	1	SCREW BHSC M6-1.0 X 12 SS
81	035461	2	BARBED STRAIGHT 1/4NPT X 3/8	127	0E9572	1	BRACKET, STEPPER MOTOR
82	0G3662	4	CLAMP, HOSE OETIKER STEPLESS 17mm	128	0D9784	1	NUT HEX LOCK M3 – 0.5 NYLON INSERT
83	0G0286	2	HOSE, 3/8" I.D. X 6" LG	129	0E5108	1	ASSY, CONTROLLER
84	0E9506	1	COOLER, OIL	130	0D6342	1	BALL STUD, 10MM
85	0C9764	4	SCREW PLASTITE 1/4-15 X 3/4	131	0E9570	1	ASSY, THROTTLE ROD
86	0C3043	2	GASKET, MANIFOLD / PORT	132	0E9577	1	BELLOWS, INTAKE
87	0C7694A	1	MANIFOLD CYLINDER 2	133	0E5846	1	EXPANSION PLUG
88	070008	4	WASHER FLAT M8 SS	134	0E9419	3	#10 O-RING
89	070006	4	WASHER LOCK M8 SSTL	135	0C4760	1	PLUG, MANIFOLD
90	040976	4	SCREW SHC M8 – 1.25 X 20 G12.9	136	0F9253	1	ASSY, AIR BOX BASE
91	045756	17	SCREW TAPTITE M6 – 1X10 YELLOW CHROME	137	0E9553	1	PIN, FUEL SELECTOR
92	0E4997	1	ASSY,GROUND WIRE CONNECTOR	138	0E9554	1	PIN, FUEL SEL STOP
93	0C3033	1	WASHER, 25MM I.D.	139	0E9348	1	SOLENOID COVER
94	0C3034	1	NUT, HEX M24	140	0E9599	1	LINKAGE, CHOKE
95	0C9763	4	NUT, GROMMET 1/4 PLUG	141	0E9595	4	SCREW PPPH HI-LO #6 X 1/2
96	0D1131	1	GUARD, FAN	142	090987	1	SCREW PHTT M3 – 0.5 X 8
97	0F1169K	1	HOUSING, BLOWER NG COOLER	143	0E9403	1	RETAINER, CHOKE RETURN SPRING
98	051754	2	SCREW HHC M8 – 1.25 X 12 G8.8	144	0E9571	1	SPRING, CHOKE RETURN
99	0A5992	2	WASHER SHAKEPROOF INT M8 SS	145	0E9380	1	WASHER, BELLEVILLE SPRING
100	0C3032	1	PLATE, FAN	146	0A6345	1	SCREW PPHM M2 – 0.4 X 8
101	0C3031	1	FAN, NYLON	147	0E9598	1	CHOKE ARM
102	0C3725B	1	FLYWHEEL ASSEMBLY	148	0E9593	1	SCREW SHOULDER M3 – 0.5 X 6
103	0F1170A	1	PLATE, BACKING WITH OIL COOLER	149	0E9564	1	VALVE, CHOKE
104	0C7693A	1	MANIFOLD CYLINDER 1	150	0E9575	1	SHAFT, CHOKE
105	0C3041A	2	SLEEVE, RUBBER	151	0E9357	1	SEAL, GOVERNOR ARM
106	082774	1	KEY, WOODRUFF 4 X 19D	152	0A7094	2	SCREW PHM #4 – 40 X 1/4
107	0C3036A	1	HOSE BREATHER	153	0E9574	1	BRACKET, SOLENOID
108	0C3019	1	WRAPPER, LOWER CYLINDER 1	154	0F9273	1	SOLENOID, 6VDC
109	0C3018	1	WRAPPER, UPPER CYLINDER 1	155	0F5467	1	NUT HEX M8 – 1.25 YELLOW ZINC
				156	0E9557	1	SPRING, CHOKE VALVE ADJUST

**Section 9 – Exploded Views and Parts Lists**

**Air-cooled Generators**

**10kW, GT-530 Engine – Drawing No. 0F9429-G - Part 1**

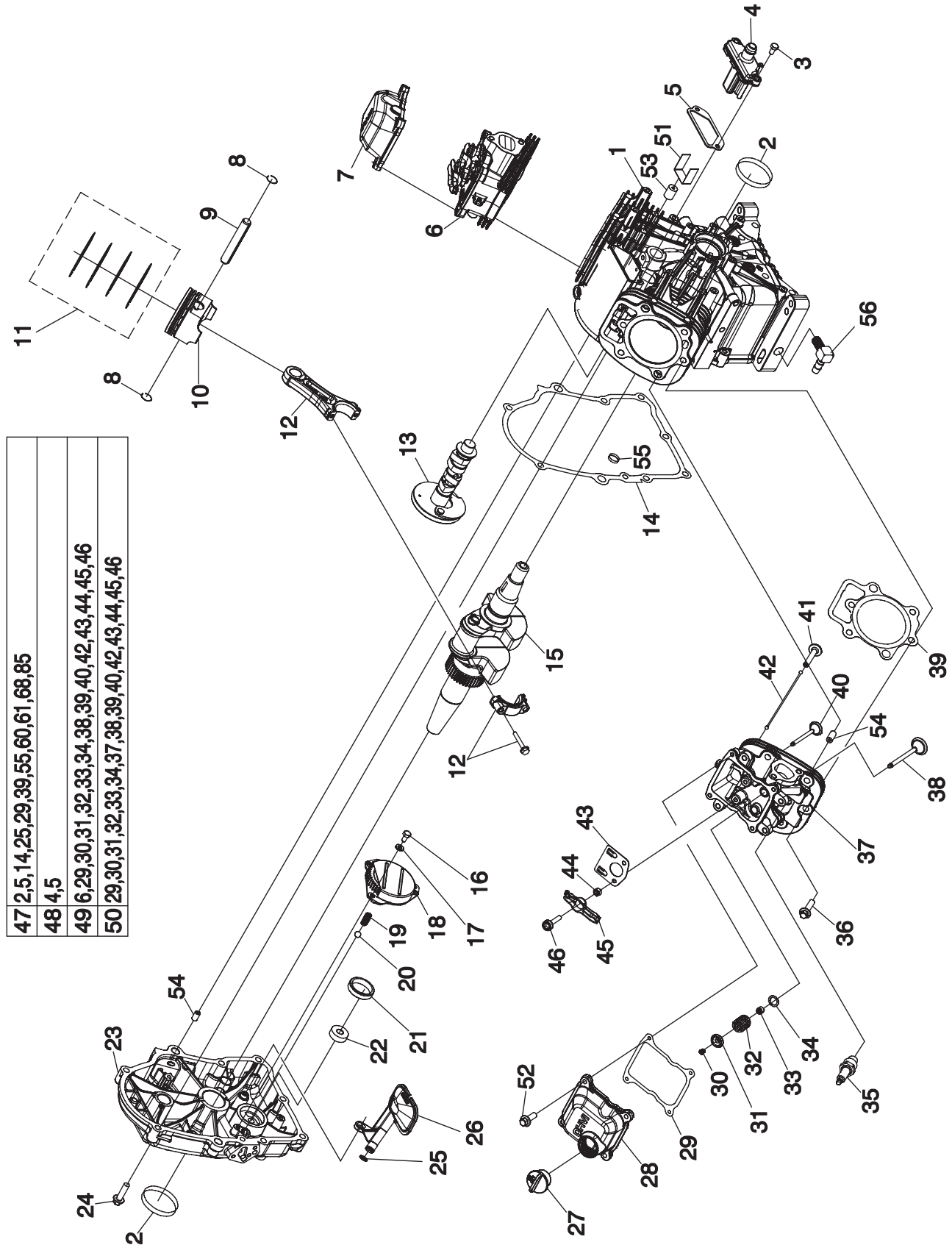

47	2,5,14,25,29,39,55,60,61,68,85
48	4,5
49	6,29,30,31,32,33,34,38,39,40,42,43,44,45,46
50	29,30,31,32,33,34,37,38,39,40,42,43,44,45,46

## Section 9 – Exploded Views and Parts Lists

### Air-cooled Generators 10kW, GT-530 Engine – Drawing No. 0F9429-G - Part 1

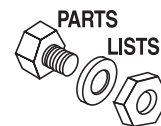

ITEM	PART NO.	QTY.	DESCRIPTION
1	0E9428B	1	CRANKCASE
2	0E3812	2	SEAL D 35 X 48.2
3	0C8566	2	SCREW HHFC M6 – 1.0 X 20
4	0E9367A	1	ASSY, BREATHER
5	0E9366	1	GASKET BREATHER ASSY
6	0E9304	1	CYLINDER HEAD 1
7	0E9334C	1	COVER, ROCKER PLAIN
8	076390	4	PISTON PIN RETAINER RING
9	076389	2	PISTON PIN
10	088057	2	PISTON
11	088411	2	PISTON RING SET
12	0E9322A	2	ASSY CONNECTING ROD
13	0E9407A	1	ASSY, CAM & GEAR
14	0E9350	1	GASKET CRANKCASE
15	0E9318E	1	ASSY CRANKSHAFT W/PLUG
16	043116	3	SCREW HHC M6 – 1.0 X 12
17	093873	3	WASHER LOCK M6 RIBBED
18	0G0272	1	ASSY GEROTOR
19	0E9482	1	SPRING OIL PRESSURE RELIEF
20	0A5776	1	BALL 11/32 DIA PRESSURE RELIEF
21	0C5315A	1	GEROTOR OUTER 9MM THICK
22	0C5314A	1	GEROTOR INNER 9MM THICK
23	0E9473	1	GEAR COVER
24	073144	9	SCREW HHFC M8 – 1.25 X 45
25	0C3027	2	O-RING 3/8 X 1/2
26	0E9358	1	SCREEN OIL PICK-UP
27	093064	1	ASSY, OIL FILL CAP
28	0E9334A	1	COVER, ROCKER, W/ FILL
29	0E9352	2	GASKET, VALVE COVER
30	0C3592	8	KEEPER, VALVE SPRING
31	0C3733	4	VALVE RETAINER
32	0C4390	4	SPRING VALVE
33	088156	2	SEAL, VALVE STEM
34	084186	4	WASHER, VALVE SPRING
35	0E9368	2	SPARKPLUG
36	077168	12	SCREW HHC M8 – 1.25 X 56
37	0E9305	1	CYLINDER HEAD 2
38	0C3590	2	VALVE EXHAUST
39	0E9351	2	GASKET CYLINDER HEAD
40	0C3591	2	VALVE INTAKE
41	083235	4	TAPPET, SOLID
42	0E9455E	4	PUSHROD, ALUMINUM
43	0E9353A	2	PLATE, PUSH ROD GUIDE
44	076307	4	NUT JAM (ROCKER ARM)
45	077160	4	ROCKER ARM
46	077161	4	STUD ROCKER ARM PIVOT
47	0G0273	1	GASKET KIT
48	0G0274	1	BREATHER KIT
49	0G0275	1	KIT HEAD ASSY CYLINDER #1
50	0G0276	1	KIT HEAD ASSEMBLY CYLINDER #2
51	0E9502	1	SEPERATOR, OIL, GT530
52	080318	12	SCREW HHFC M6 – 1.0 X 25
53	0E3372C	1	SEPARATOR, OIL BREATHER GT530
54	078699B	6	SLEEVE DOWEL PIN 12 DIA.
55	0C5943	1	SEAL, OIL PASSAGE
56	043790	1	BARBED EL 90 3/8 NPT X 3/8

Section 9 – Exploded Views and Parts Lists

Air-cooled Generators

10kW, GT-530 Engine – Drawing No. 0F9429-G - Part 2

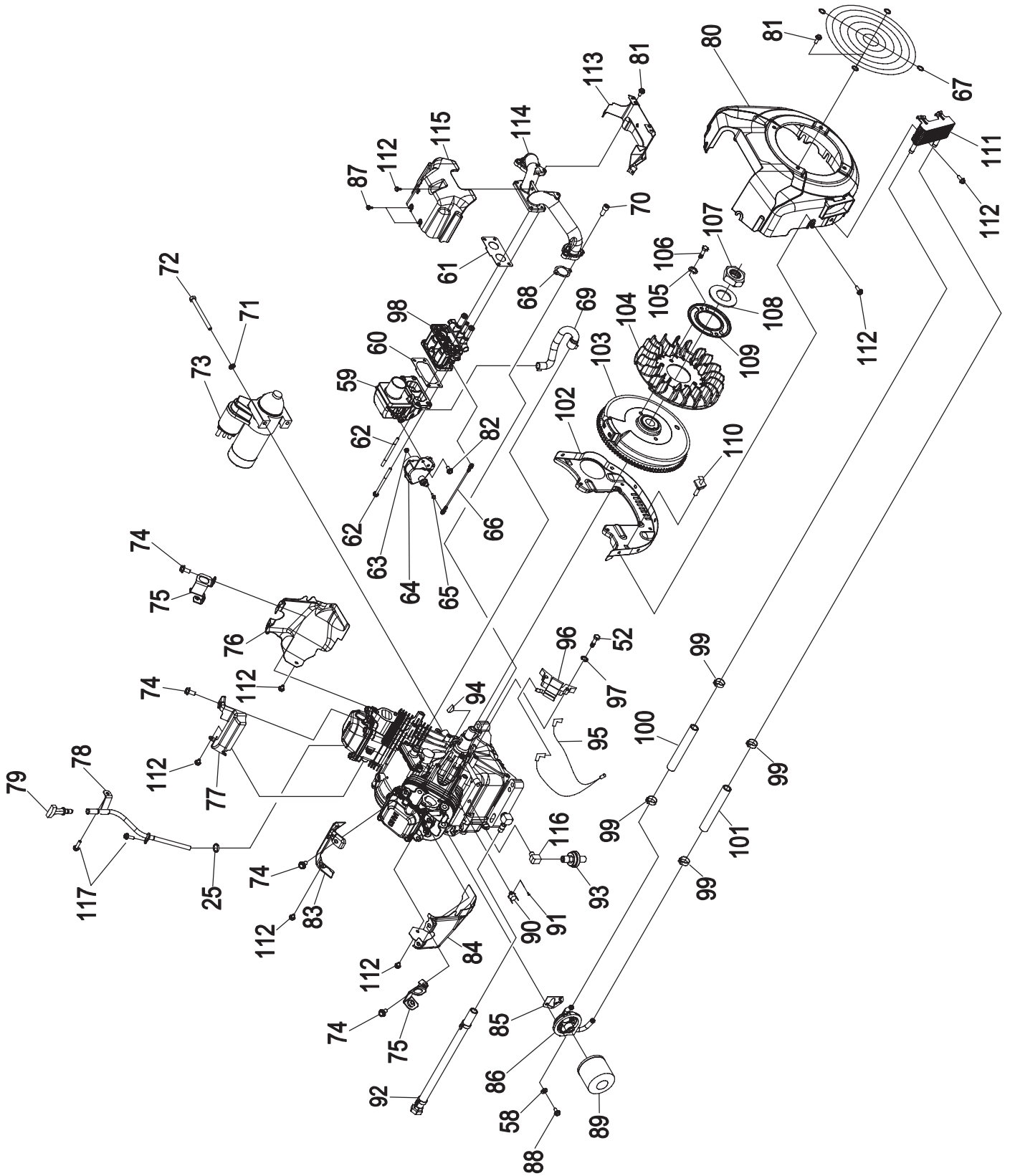



## Section 9 – Exploded Views and Parts Lists

### Air-cooled Generators 10kW, GT-530 Engine – Drawing No. 0F9429-G - Part 2

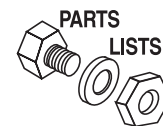

ITEM	PART NO.	QTY.	DESCRIPTION	ITEM	PART NO.	QTY.	DESCRIPTION
58	022097	3	WASHER LOCK M6-1/4	89	070185B	1	OIL FILTER
59	0E9561	1	INTAKE ADAPTER	90	094090	1	THERMAL SWITCH
60	0E9472	1	GASKET, AIRBOX TO CARB/MIXER	91	0F2094	2	SCREW PPHM M3-0.5 X 6 SEMS
61	0E9471	1	GASKET, MANIFOLD TO CARB/MIXER	92	0D3083	1	ASSEMBLY, OIL DRAIN HOSE
62	078643B	4	BOLT, CARB MOUNT M6 – 1.0 X 85	93	0A8584	1	OIL PRESSURE SWITCH
63	0D9784	1	NUT HEX LOCK M3 – 0.5	94	082774	1	KEY, WOODRUFF 4 X 19D
64	0E9584	1	ASSY, CONTROLLER	95	0E7209	1	ASSY, GROUNDING WIRE
65	0D6342	1	BALL STUD, 10 MM	96	0E9514B	1	ASSY IGNITION COIL CYLINDER 1
66	0E9587	1	ASSY, THROTTLE ROD		0E9514C	1	ASSY IGNITION COIL CYLINDER 2
67	0C9997	1	GUARD, FAN	97	026850	4	WASHER SHAKEPROOF EXT 1/4
68	0E9319	2	GASKET INTAKE	98	0E9443	1	ASSY, MIXER DUAL FUEL
69	0E9597	1	BREATHER HOSE	99	0G3662	4	CLAMP, HOSE OETIKER STEPLESS 17mm
70	040976	4	SCREW SHC M8 – 1.25 X 20 G12.9				
71	022129	2	WASHER LOCK M8 – 5/16	100	0G0286	1	HOSE 3/8"ID X 6" SAE J30R9
72	061906	2	SCREW HHC M8 – 1.25 X 85	101	0G0479	1	HOSE 3/8"ID X 7.25 SAE J30R9
73	0E9323	1	STARTER MOTOR	102	0E9340	1	BACKING PLATE
74	0E9507	6	SCREW HHFC M8 – 1.25 X 14	103	0E9525C	1	ASSY, FLYWHEEL & RING GEAR
75	0E9362	2	LIFTING HOOK	104	0E9486	1	FAN, FLYWHEEL, 20 FIN, 218.8 OD
76	0E9337	1	WRAPPER OUTER CYLINDER 1	105	0A5992	2	WASHER LOCK INT M8
77	0E9339	1	WRAPPER INNER CYLINDER 1	106	048571	2	SCREW HHC M8 – 1.25 X 10
78	0E9402	1	TUBE, DIPSTICK	107	067890	1	NUT HEX M20 – 1.5
79	0F2664H	1	ASSY, DIPSTICK /TEXT	108	067198N	1	WASHER BELV – 20 X 2.2
80	0E9336F	1	BLOWER HOUSING	109	0C3032	1	PLATE, FAN
81	0D6147	6	SCREW HHFC M6-1.0 X 10 G8.8	110	0E4997	1	ASSY, GROUND WIRE CONNECTOR
82	0E5139	3	SCREW HHFC M6-1.0 X 8 G8.8	111	0E9406	1	OIL COOLER
83	0E9432	1	WRAPPER INNER CYLINDER 2	112	0G1705	17	SCREW HHFC M6 – 1.0 X 14
84	0E9338	1	WRAPPER OUTER CYLINDER 2	113	0E9450	1	CENTER BAFFLE
85	0E9370	1	GASKET, OIL FILTER ADAPTER	114	0E9376	1	INTAKE MANIFOLD
86	0E9505A	1	ASSY, DIRECT OIL COOLER ADAPTER	115	0E9550	1	FRONT COVER
87	0F5458	2	SCREW PLASTITE HI-LOW #10X3/8	116	028916	1	ELBOW – 1/8" NPT
88	045757	3	SCREW HHC M6 – 1.0 X 25	117	0C8563	2	SCREW, HHFC M6-1.0 x 12

## Section 9 – Exploded Views and Parts Lists

Air-cooled Generators

7kW, GN-410 Engine – Drawing No. 0F9428-C - Part 1

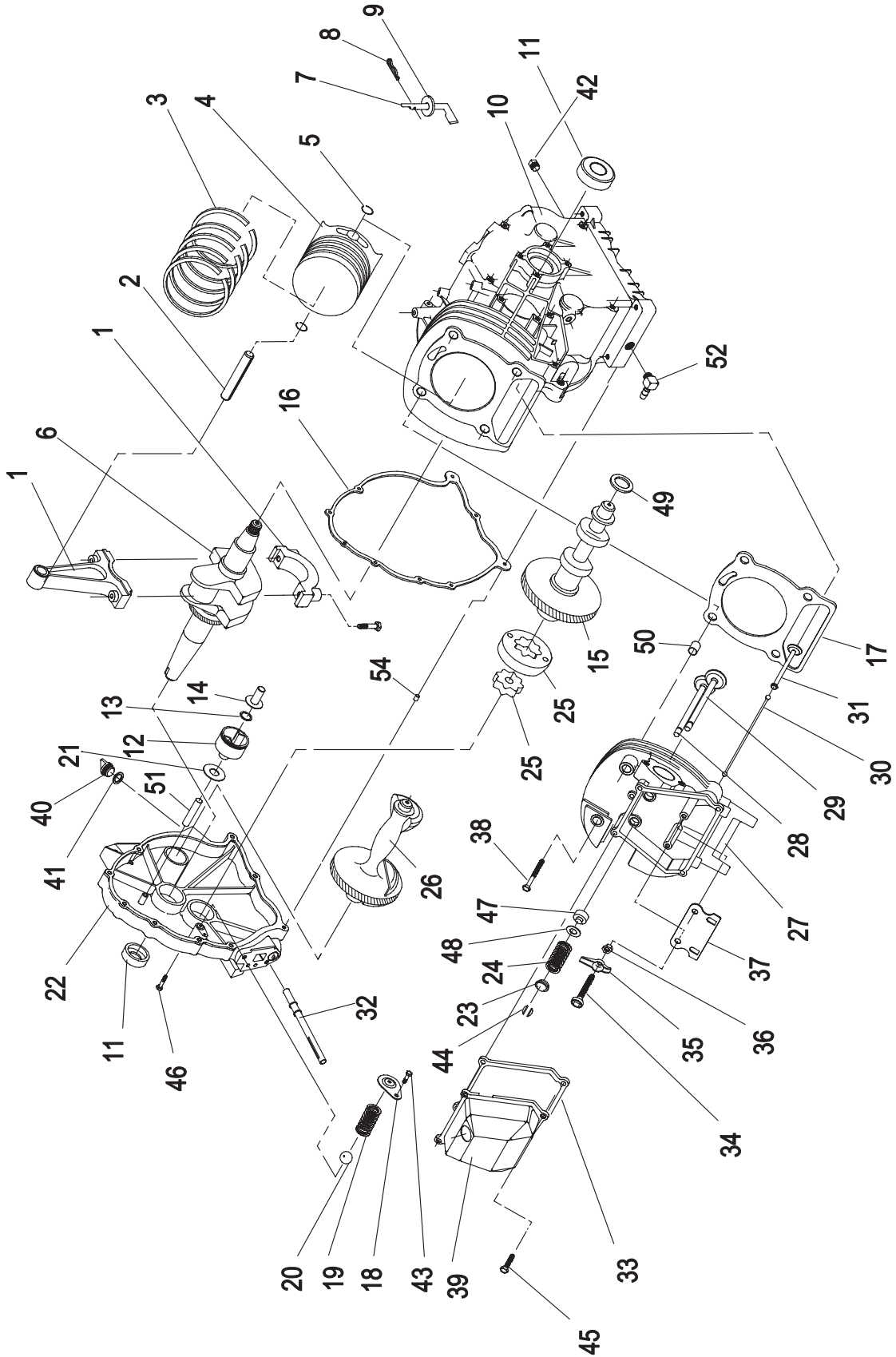

## Section 9 – Exploded Views and Parts Lists

### Air-cooled Generators 7kW, GN-410 Engine – Drawing No. 0F9428-C - Part 1

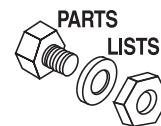

ITEM	PART NO.	QTY.	DESCRIPTION
1	0E3221	1	ASSEMBLY, CONNECTING ROD
2	0E1466	1	PIN, PISTON D20
3	021533	1	SET, PISTON RING 90MM
4	0E2985	1	PISTON, HC
5	071983	2	RETAINER, PISTON PIN 20
6	0E8440	1	ASSEMBLY, CRANKSHAFT GH410 SMALL TAPER
7	0A7628	1	ARM, GOVERNOR RC45
8	078658	1	PIN, "R" GOVERNOR ARM
9	078659	2	WASHER, GOVERNOR ARM THRUST
10	088261E	1	CRANKCASE, SUBASSEMBLY WITH PLUGS GH410
11	0E3812	2	SEAL, 35 I.D. CRANKSHAFT
12	0E6519	1	ASSEMBLY, GOVERNOR GEAR
13	078645	1	C-RING, GOVERNOR GEAR RETAINER
14	0A7811	1	SPOOL, GOVERNOR- MACHINE
15	0G3358	1	ASSEMBLY, CAMSHAFT & GEAR 410HSB
16	076701	1	GASKET , CRANKCASE
17	021713B	1	GASKET, HEAD 410
18	078691	1	COVER, OIL PRESSURE RELIEF
19	0A5771	1	SPRING, OIL RELIEF 360
20	0A5776	1	BALL, DIA 11/32 PRESSURE RELIEF
21	076361	1	WASHER, THRUST GOVERNOR GEAR
22	0A8898D	1	ASSEMBLY, COVER, GEAR TOP CHECK / FILL
23	0D2274	2	RETAINER, VALVE SPRING
24	0C4391	2	VALVE SPRING LF
25	086025	1	SET,GEROTOR 12 THK
26	0E3341	1	BALANCER
27	021714	1	ASSEMBLY,CYLINDER HEAD SEATS & GUIDES
28	086516	1	VALVE, EXHAUST
29	086517	1	VALVE, INTAKE
30	0D9853B	2	PUSH ROD 174.9
31	083897	2	TAPPET
32	077158	1	ASSEMBLY, SCREEN OIL PICK-UP
33	0C3150	1	GASKET, ROCKER COVER 410
34	072694	2	STUD, D20 PIVOT BALL
35	083907	2	ROCKER ARM
36	0D3998	2	NUT, JAM (ROCKER ARM)
37	078694	1	PLATE, PUSH ROD GUIDE
38	021742	4	SCREW, HHFL M10-1.5 X 105
39	0D6094	1	ASSEMBLY, ROCKER COVER BREATHER
40	076329	1	PLUG, OIL FILL PLASTIC
41	0E0057	1	O-RING 17.8 I.D. x 2.4
42	0D4788	1	PLUG, STANDARD PIPE 3/8 STEEL SQUARE HEAD
43	074908	1	SCREW, TAPTITE M5-0.8 X 10 BP
44	086515	4	KEEPER, VALVE SPRING
45	078606	4	SCREW & LOCKWASHER M6-1 X 12
46	0A1442	8	SCREW, HHFC M8-1.25 X 42
47	078672	1	SEAL, VALVE STEM D7
48	089673	2	WASHER, VALVE SPRING
49	0B2104	1	WASHER, LARGE SPRING
50	078699C	2	DOWEL, SEAMED SLEEVE
51	0A7627	1	SHAFT, GOVERNOR RC55
52	043790A	1	BARBED ELBOW 90 3/8NPT X 3/8 LOCKTITE
53			
54	078699B	2	DOWEL, SLEEVE SEAMED 12 DIA.

**Section 9 – Exploded Views and Parts Lists**

**Air-cooled Generators**

**7kW, GN-410 Engine – Drawing No. 0F9428-C - Part 2**

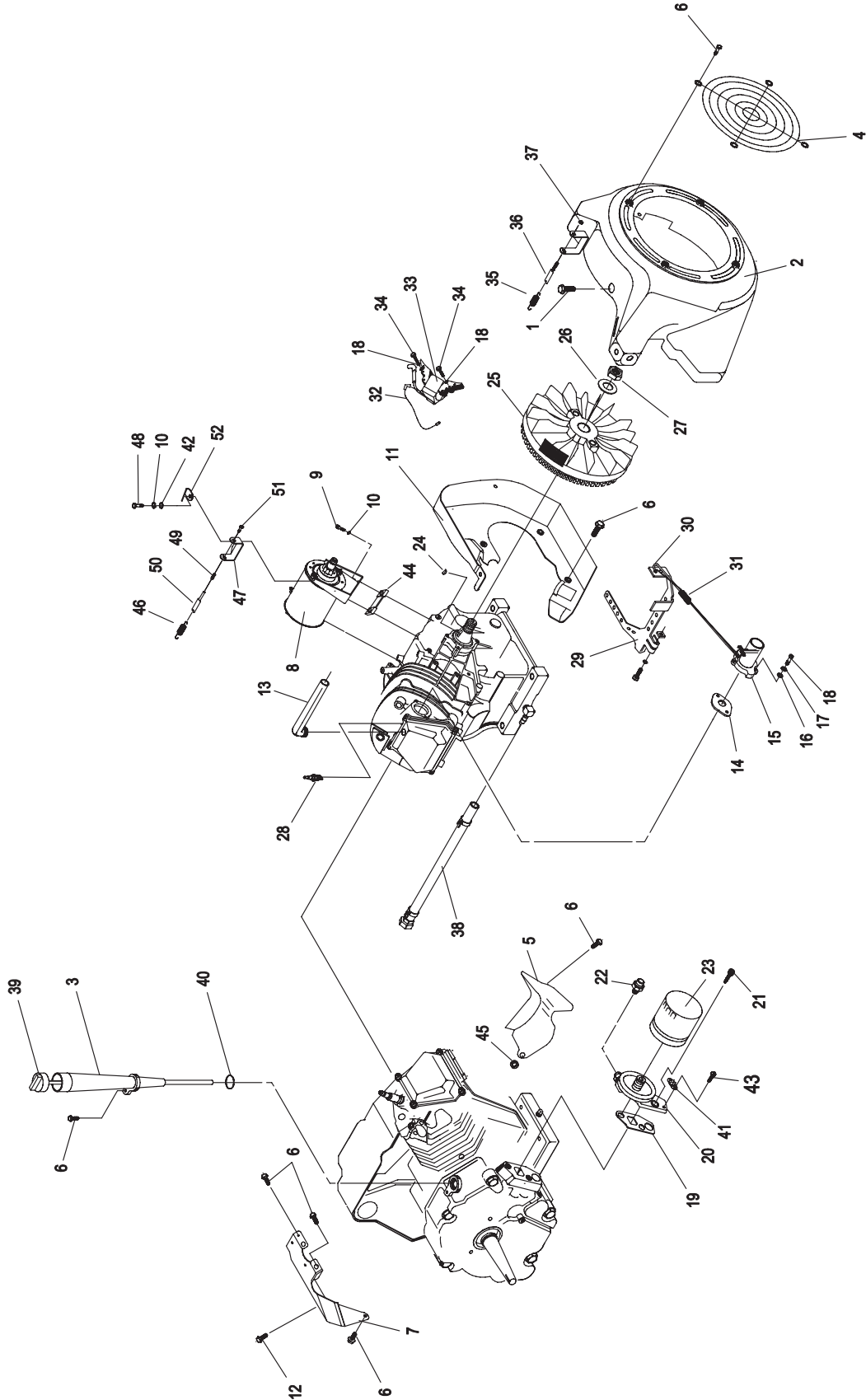

## Section 9 – Exploded Views and Parts Lists

### Air-cooled Generators 7kW, GN-410 Engine – Drawing No. 0F9428-C - Part 2

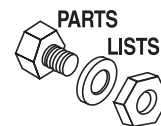

ITEM	PART NO.	QTY.	DESCRIPTION
1	0C1069	5	SCREW, TAPTITE M6-1.0X8 YELLOW CHROME
2	0D2922	1	HOUSING, BLOWER
3	0F8426	1	TUBE, DIPSTICK
4	0C9997	1	GUARD, FAN
5	088434	1	WRAPPER, BOTTOM
6	045756	11	SCREW, TAPTITE M6-1X10 YELLOW CHROME
7	0C4176A	1	WRAPPER, TOP
8	0D9004A	1	ASSY, STARTER
9	059985	2	SCREW, SHC M8-1.25 X 45 G12.9
10	022129	3	WASHER, LOCK M8-5/16
11	0C2458A	1	BACKPLATE, L/F D/F
12	083512	1	SCREW, TAPTITE M8-1.25 X 16 BP
13	0D1401A	1	BREATHER TUBE
14	091039	1	GASKET, INTAKE ADAPTER
15	0C9619	1	ASSEMBLY, PLASTIC CARB
16	049811	2	WASHER, FLAT M6
17	022097	4	WASHER, LOCK M6-1/4
18	040945	2	SCREW, SHC M6-1.0 X 20 G12.9
19	086999	1	GASKET,OIL FILTR ADAPTER
20	0D5667A	1	ADAPTER, OIL FILTER
21	049821	2	SCREW, SHC M8-1.25 X 30 G12.9
22	099236	1	SWITCH, OIL 8.0 PSI
23	070185B	1	OIL FILTER
24	082774	1	KEY, WOODRFF 4 X 19D
25	091222E	1	FLYWHEEL WITH RING GEAR 32DEG.
26	067198N	1	WASHER,BELV-20 X 2.2
27	067890	1	NUT, HEX - FLYWHEEL
28	0E7585	1	SPARKPLUG
29	072734	1	ASSEMBLY,GOVERNOR LEVER 12 HP
30	072735	1	ROD,GOVERNOR CONTROL.
31	0C3978	1	SPRING, ANTI-LASH
32	0C6040	1	ASSEMBLY, WIRE
33	0D9760	1	ASSEMBLY, IGNITION COIL
34	0G3111	2	SCREW, TAPTITE M6-1.0 X 25 ZINC
35	0F3800	1	SPRING GOVERNOR
36	083502	1	BOLT, GOVERNOR ADJUST M5
37	082025	1	NUT HEX LOCK M5-0.8 NYINS ZINC
38	0D3083	1	ASSEMBLY, OIL DRAIN HOSE
39	0E7887C	1	ASSEMBLY, CAP & DIPSTICK
40	090072	1	O-RING 9/16 X 3/4 X 3/32
41	094090	1	SWITCH, THERMAL 293F
42	022145	1	WASHER FLAT 5/16 - M8
43	0F2094	2	SCREW, M3-0.5 X 6 SEMS
44	0C4373	1	SPACER ENDFRAME
45	022717B	1	GOMMET
46	0F3865	1	SPRING SECONDARY
47	0F3855	1	BRACKET SECONDARY GOVERNOR SPRING
48	039253	1	SCREW HHC M8-1.25 x 20
49	0D3751	1	SPRING, IDLE RETURNING
50	0F3921	1	BARREL GOVERNOR ADJUSTMENT
51	0C8493	1	SCREW SHC M5-0.8 x 30
52	0D8758	1	ENGINE LIFT HOOK

## Section 9 – Exploded Views and Parts Lists

### Air-cooled Generators

7kW, GN-410 Engine – Drawing No. 0F9422-C

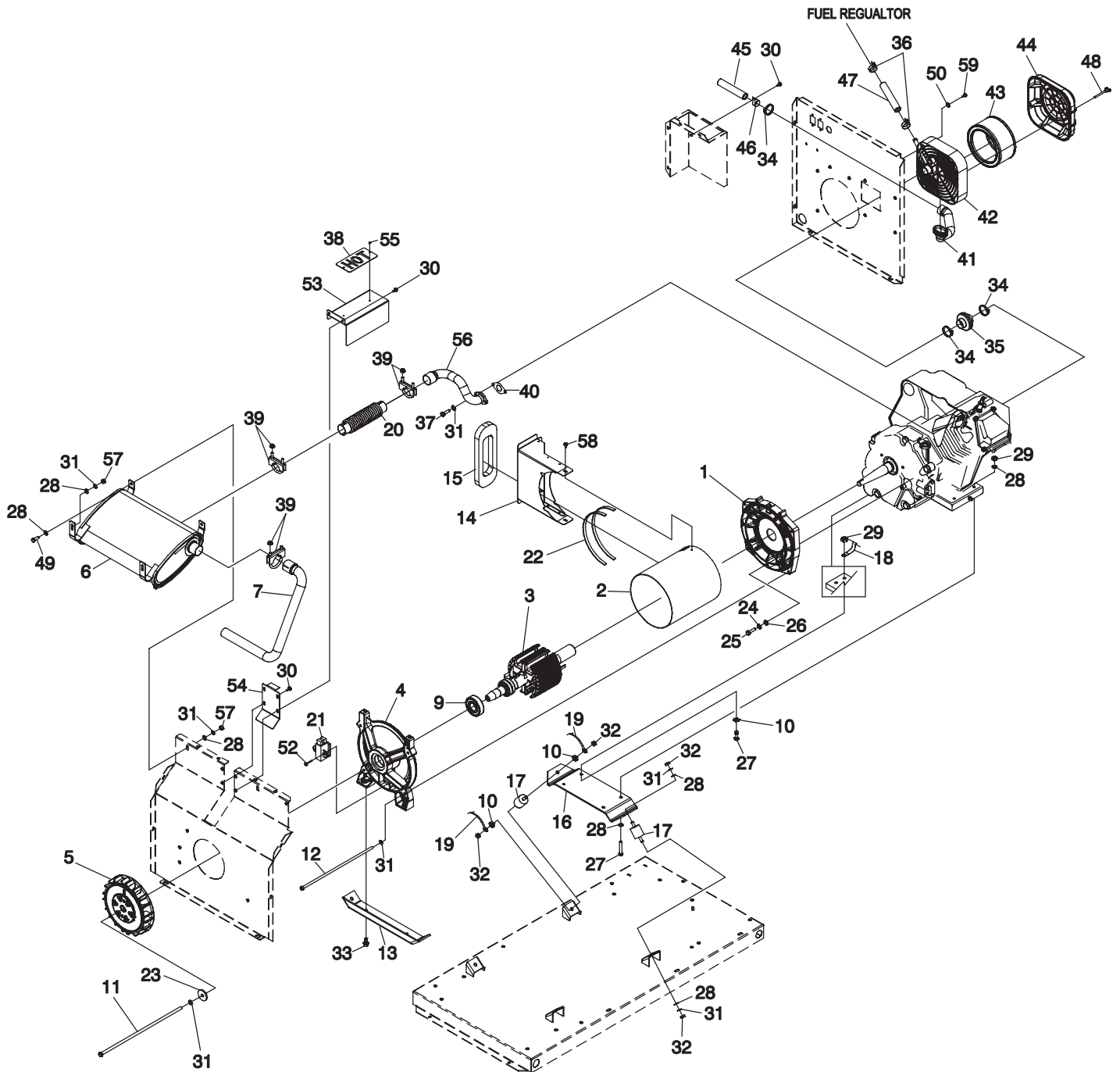

## Section 9 – Exploded Views and Parts Lists

### Air-cooled Generators 7kW, GN-410 Engine – Drawing No. 0F9422-C

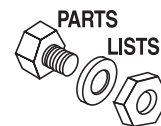

ITEM	PART NO.	QTY.	DESCRIPTION
1	0F8186	1	ADAPTOR, ENGINE
2	0F5540H	1	STATOR
3	0C9934H	1	ROTOR
4	0F7774A	1	CARRIER, REAR BEARING
5	0C8096	1	FAN, 8" CURVED BLADE
6	0F6591	1	MUFFLER
7	0F8078	1	TAIL PIPE, MUFFLER
9	056482	1	BEARING
10	0C3168	3	5/16 SPECIAL L/WASH
11	056147	1	BOLT ROTOR HHCS 5/16"-24 X 13-1/2" G5
12	0D1847	4	BOLT STATOR IHCS M8-1.25 x 305mm
13	0C7038C	1	BRACKET, ALTERNATOR MOUNTING
14	0F9445	1	DUCT, ALTERNATOR AIR
15	0F9497	1	GASKET, ALTERNATOR AIR DUCT
16	0C7038B	1	BRACKET, ENGINE MOUNTING
17	0C7758	4	RUBBER MOUNT
18	0388050AEO	1	CABLE, #6 40" BLACK BATTERY
19	0C2417A	1	EARTH STRAP 3/8X 3/8
20	0F6528	1	EXHAUST FLEX
21	066386	1	ASSEMBLY BRUSH HOLDER
22	029451	1.8 FT	TAPE ELEC UL FOAM 1/8 X 1/2
23	049451	1	WASHER FLAT .406ID X 1.62OD
24	022237	4	WASHER LOCK 3/8
25	022511	4	BOLT HHC 3/8-16 X 1-1/4 G5
26	022131	4	WASHER FLAT 3/8
27	039287	4	SCREW HHC M8-1.25 X 45 G8.8
28	022145	18	WASHER FLAT 5/16
29	049820	4	NUT LOCK HEX M8-1.25 NYL INSRT
30	090388	8	SCREW TAP M6-1.0X12
31	022129	17	WASHER LOCK M8-5/16
32	022259	8	NUT HEX 5/16-18
33	059637	2	SCREW TAPTITE 3/8-16X 3/4"
34	048031K	3	BAND, HOSE CLAMP 35.05 DIA.
35	0C9592	1	BELLOWS
36	048031M	2	HOSE CLAMP 3/4"
37	040976	2	SCREW SHC M8-1.25 X 20 G12.9
38	0G0414	1	PLATE "HOT"
39	0D5823	3	U-BOLT 5/16"-18 X 1.62" W/ SADDLE
40	090239	1	GASKET, EXHAUST
41	0C6989	1	STINGER, ENGINE AIR IN
42	0D1214	1	BASE, AIR CLEANER
43	0C8127	1	ELEMENT, AIR CLEANER
44	0C3024	1	COVER, AIR CLEANER NG/LP
45	0D2273	1	TUBE, 1.25"O.D. x 20Ga. x 12.125" LONG
46	055934N	1	CLAMP VINYL 1.31 X .281 Z
47	0F7065	1.25 FT	HOSE LP 1/2" I.D.
48	0C5136A	2	KNOB, AIR CLEANER
49	039253	2	SCREW HHC M8-1.25 X 20 G8.8
50	022473	4	WASHER FLAT 1/4
52	066849	2	SCREW HHTT M5-0.8 X 16
53	0F6551	1	FLEX COVER
54	0F8079	1	BRACKET MUFFLER ACCESS
55	0F0710	2	RIVET POP 0.125" X 0.337"
56	0F8256	1	EXHAUST MANIFOLD
57	045771	4	NUT HEX M8-1.25 NY INS
58	0G0676	2	SCREW THTT M6-1.0 X 10
59	074906	4	SCREW HHTT M6-1.0 X 20

**Section 9 – Exploded Views and Parts Lists**

**Air-cooled Generators**

**10, 13, and 16kW, V-twin Generators – Drawing No. 0F9423-C**

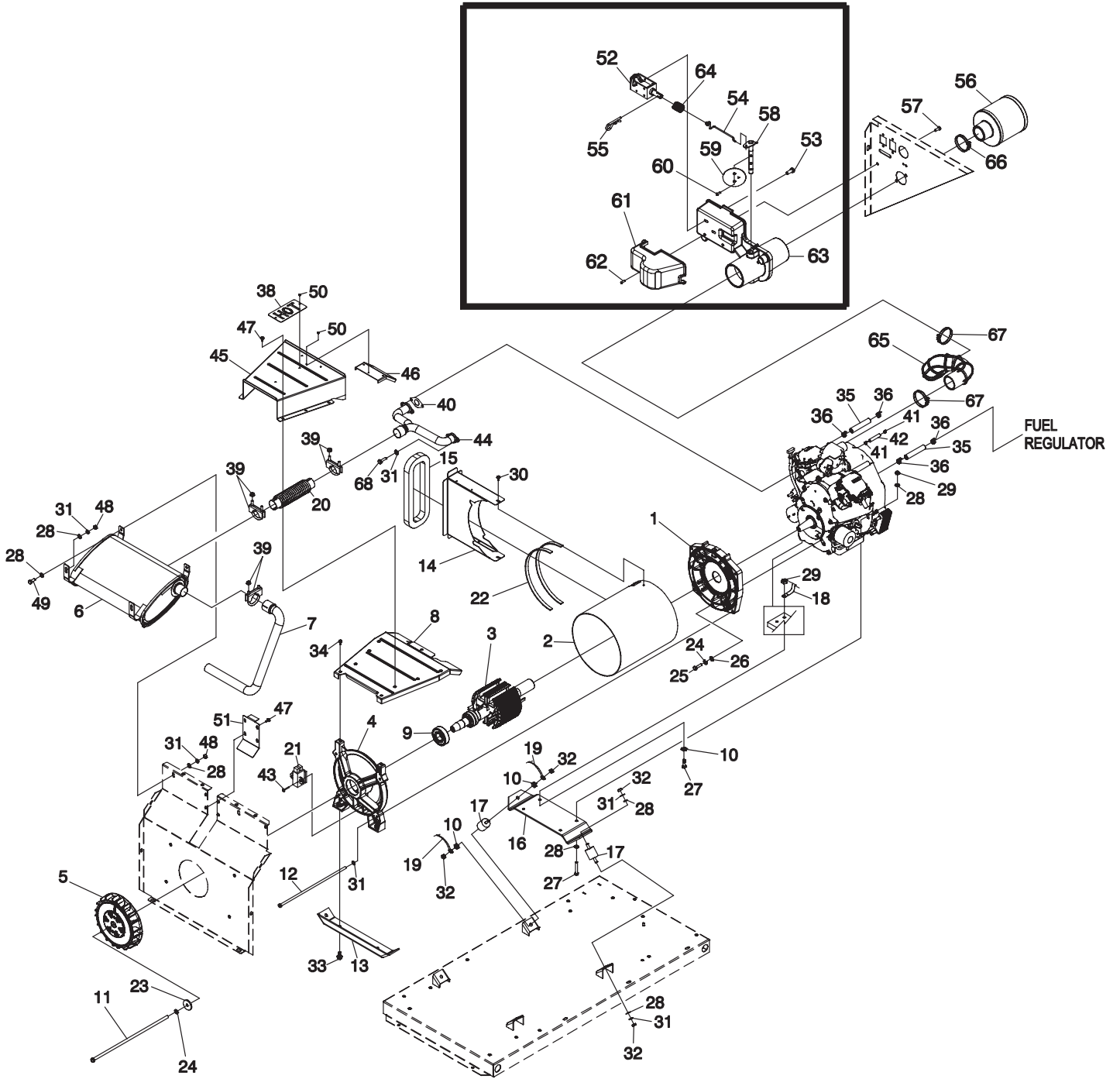



## Section 9 – Exploded Views and Parts Lists

### Air-cooled Generators 10, 13, and 16kW, V-twin Generators – Drawing No. 0F9423-C

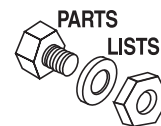

ITEM	PART NO.	QTY.	DESCRIPTION	ITEM	PART NO.	QTY.	DESCRIPTION
1	0F8186	1	ADATOR, ENGINE	34	0D4662	3	SCREW 5/16-18 X 3/4"
2	0F6694	1	STATOR (16KW)	35	0F7065	3 FT	HOSE RES 1/2 LP GAS
	0F5538	1	STATOR (13KW)	36	048031M	4	HOSE CLAMP 3/4" I.D.
	0F7548	1	STATOR (10KW)	38	0G0414	1	PLATE, "HOT"
3	0F9795	1	ROTOR (16KW)	39	0D5823	3	U-BOLT 5/16"-18 X 1.62" WITH SADDLE
	0F5539	1	ROTOR (13KW)	40	0E9369	2	GASKET, EXHAUST PORT (10KW)
	0F7549	1	ROTOR (10KW)		0C4138	2	GASKET, EXHAUST PORT
4	0F7774	1	CARRIER, REAR BEARING	41	040173	2	CLAMP HOSE #5.5 0.62"-0.62" (10KW)
5	0E9579	1	FAN, 12" CURVED BLADE	42	074995	1.44 FT	HOSE 1/4 ID LPG 350PSI UL21 (10KW)
	0F8998	1	FAN, 12" CURVED BLADE (10KW)	43	066849	2	SCREW HHTT M5-0.8 X 16
6	0F6591	1	MUFFLER	44	0F7799	1	EXHAUST MANIFOLD
7	0F8078	1	TAIL PIPE, MUFFLER		0F8115	1	EXHAUST MANIFOLD (10KW)
8	0F7797	1	FLEX BASE	45	0F7796	1	FLEX COVER
	0F8141	1	FLEX BASE (10KW)		0F8204	1	FLEX COVER (10KW)
9	056482	1	BEARING	46	0F9385	1	FLEX COVER EXTENSION (10KW)
10	0C3168	3	5/16 SPECIAL LOCK WASHER	47	090388	13	SCREW TAPTITE M6-1.0 X 12
11	0D1838	1	BOLT, IHCS 3/8"-24 X 15.50"	48	045771	4	NUT HEX M8-1.25
12	0D1846	4	BOLT, IHCS M8-1.25 X 345mm	49	039253	2	SCREW HHC M8-1.25 X 20
13	0C7038	1	BRACKET, ALTERNATOR MOUNTING	50	0F0710	5	RIVET POP 0.125" X 0.337" (10KW)
14	0F9396	1	DUCT, ALTERNATOR AIR		0F0710	2	RIVET POP 0.125" X 0.337"
15	0D2559	1	GASKET, ALTERNATOR AIR DUCT	51	0F8079	1	BRACKET MUFFLER ACCESS
16	0C7038A	1	BRACKET, ENGINE MOUNTING	52	0F9273	1	SOLENOID, 6 VOLTS DC (10KW)
	0F4179	1	PLATE, MOUNTING ENG 530HSB	53	0E9592	2	SCREW PPHM \$4-40 X 3/8 SEMS (10KW)
17	0C7758	4	RUBBER MOUNT	54	0E9588	1	LINKAGE, CHOKE (10KW)
18	0388050ADO	1	CABLE, #6 48" BLACK BATTERY	55	077091	1	COTTER PIN (10KW)
19	0C2417A	1	EARTH STRAP 3/8 X 3/8	56	0E9581	1	AIR CLEANER GTH530 HSB (10KW)
20	0F6528	1	EXHAUST FLEX	57	0E9594	3	SCREW PPH HI-LO #14-15 X 1/2 (10KW)
21	066386	1	ASSEMBLY BRUSH HOLDER	58	0E9590	1	ASSEMBLY, CHOKE SHAFT (10KW)
22	029451	2.6 FT	TAPE ELEC UL FOAM 1/8 X 1/2	59	0E9542	1	VALVE, CHOKE (10KW)
23	049451	1	WASHER FLAT .406ID X 1.62OD	60	0D1683	2	SCREW PFHM M3-0.5 X 5 (10KW)
24	022237	5	WASHER LOCK 3/8	61	077075	1	BOOT, CHOKE SOLENOID (10KW)
25	022511	4	SCREW HHC 3/8 X 16 X 1-1/4	62	0E9595	2	SCREW PPH HI-LO #6/1/2 W/ #5HD (10KW)
26	022131	4	WASHER FLAT 3/8 ZINC				
27	051731	4	SCREW HHC M8-1.25 X 50	63	0E9589	1	CHOKE HSG (10KW)
28	022145	18	WASHER FLAT 5/16 ZINC	64	0E9591	1	SPRING-CHOKE RETURN (10KW)
29	049820	4	NUT LOCK HEX M8-1.25 NYL INSERT	65	0E9549	1	HOSE, INTAKE GTH530 HSB (10KW)
30	0G0676	2	SCREW THTT M6-1.0 X 10	66	035685	1	CLAMP HOSE #28 1.32-2.25
31	022129	18	WASHER LOCK M8-5/16	67	099502	2	CLAMP HOSE #24 B1.06-2.00
32	022259	8	NUT LOCK HEX 5/16-18	68	0C8565	4	SCREW SHC M8-1.25 X 18 G8.8
33	059637	2	SCREW TAPTITE 3/8-16 X 3/4				

**Section 9 – Exploded Views and Parts Lists**

**Air-cooled Generators**

**7 & 10kW, GN-410/GT-530 Regulator – Drawing No. 0F9425**

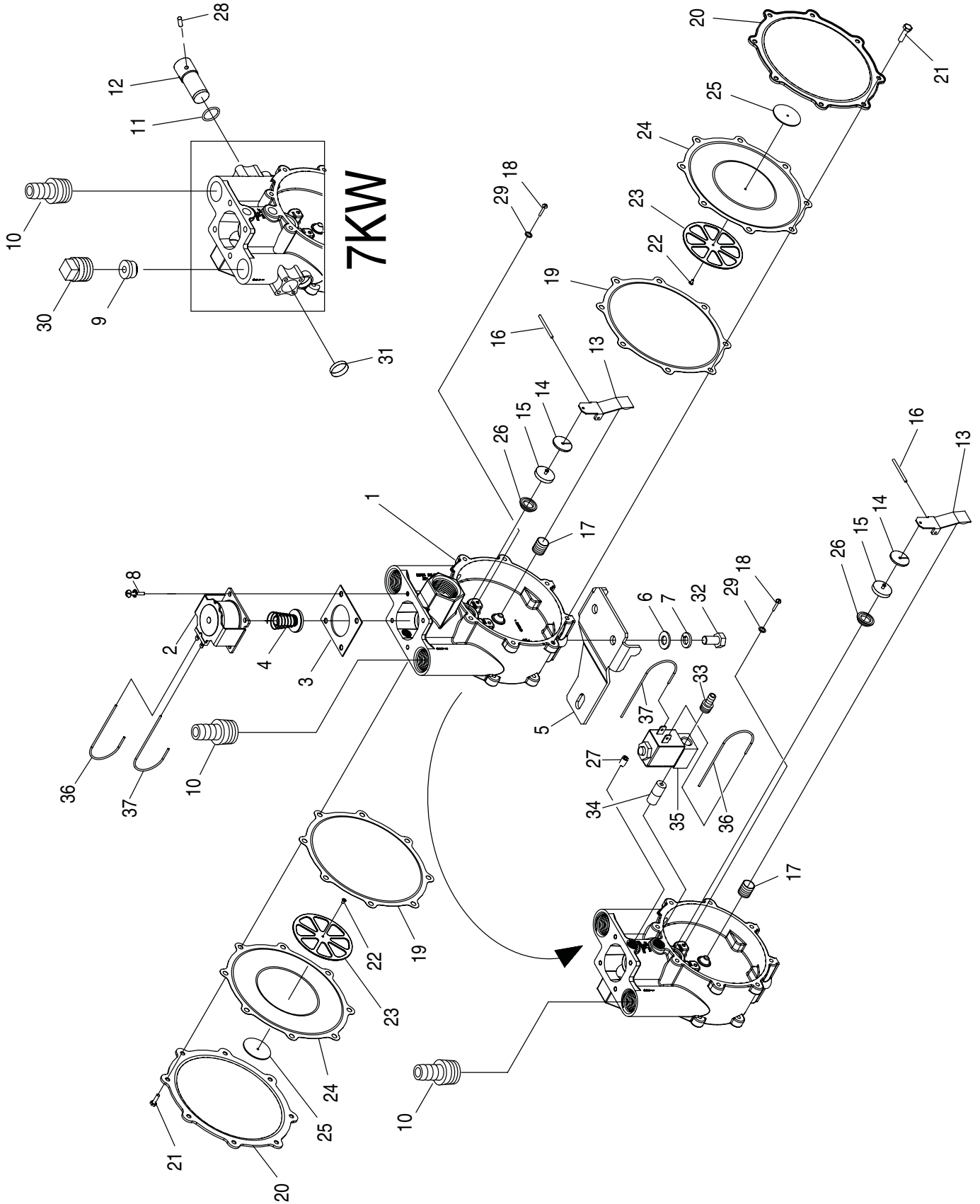

## Section 9 – Exploded Views and Parts Lists

### Air-cooled Generators 7 & 10kW, GN-410/GT-530 Regulator – Drawing No. 0F9425

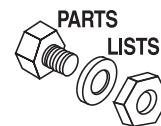

ITEM	PART NO.	QTY.	DESCRIPTION
1	0D5694	1	CASTING, TWIN REGULATOR HOUSING (7KW)
	0F9285	1	CASTING, TWIN REGULATOR HOUSING
2	0F5022	1	SOLENOID COIL, 12VDC
3	0C4647	1	GASKET , SOLENOID
4	0D4166	1	PLUNGER, LP REGULATOR ASSEMBLY
5	0F8822	1	REGULATOR BRACKET
6	022145	2	WASHER FLAT 5/16-M8
7	022129	2	WASHER LOCK 5/16-M8
8	0F4795	4	SCREW PPHM SEMS M4-0.7 X 10
9	0C5760P	1	FUEL JET GASEOUS REGULATOR (7KW)
10	0C6606	1	BARBED STRAIGHT ½ NPT x ½ (7KW)
	0C6606	2	BARBED STRAIGHT ½ NPT x ½
11	097934	1	O-RING (7KW)
12	0C4645	1	ADJUSTER SCREW, TWIN REGULATOR (7KW)
13	0C5761	2	LEVER, REGULATOR
14	0C5968	2	SUPPORT, INLET SEAL
15	0C6066	2	SEAL, INLET
16	0C5759	2	PIN, PIVOT ARM
17	0C5764A	2	SPRING, REGULATOR (7KW)
	0C5764	2	SPRING, REGULATOR
18	070728	4	SCREW, PFHMS M3-0.5 x 5
19	0C6069	2	GASKET, DIAPHRAGM
20	0C5762	2	COVER, TWIN REGULATOR (7KW)
	0F9189	2	COVER, TWIN REGULATOR
21	045764	16	SCREW, TAPTITE M4X8 BP
22	0C6731	2	RIVET, POP .118 X .125
23	0C6067	2	SUPPORT, DIAPHRAGM
24	0C4706	2	DIAPHRAGM, TWIN REGULATOR
25	0C6068	2	CAP, DIAPHRAGM SUPPORT
26	0C4643A	2	INLET, TWIN REGULATOR 11.11 DIA.
27	072683A	2	PLUG STD PIPE 1/8 SOCKET HEAD (7KW)
	072683A	1	PLUG STD PIPE 1/8 SOCKET HEAD
28	0A4032	1	PIN, LIMITED ADJUSTMENT (7KW)
29	0D3308	4	WASHER, FLAT M3 X 10mm O.D.
30	024310	1	PLUG, STANDARD PIPE 1/2" STEEL SQUARE HEAD (7KW)
31	0D3973	1	PLUG, EXPANSION 16mm (7KW)
32	042907	2	SCREW HHC M8-1.25 X 16
33	028414A	1	BARBED STRAIGHT 1/8"NPT X ¼" (10KW)
34	035578A	1	NIPPLE CLOSE 1/8NPT (10KW)
35	0G0247	1	SOLENOID, LP/NG DC12V (10KW)
36	0F9773B	1	SOLENOID WIRE, #0 (10KW)
37	0F9773A	1	SOLENOID WIRE, #14 (10KW)

**Section 9 – Exploded Views and Parts Lists**

**Air-cooled Generators**

**13 & 16kW, GT-990 Regulator – Drawing No. 0F9426**

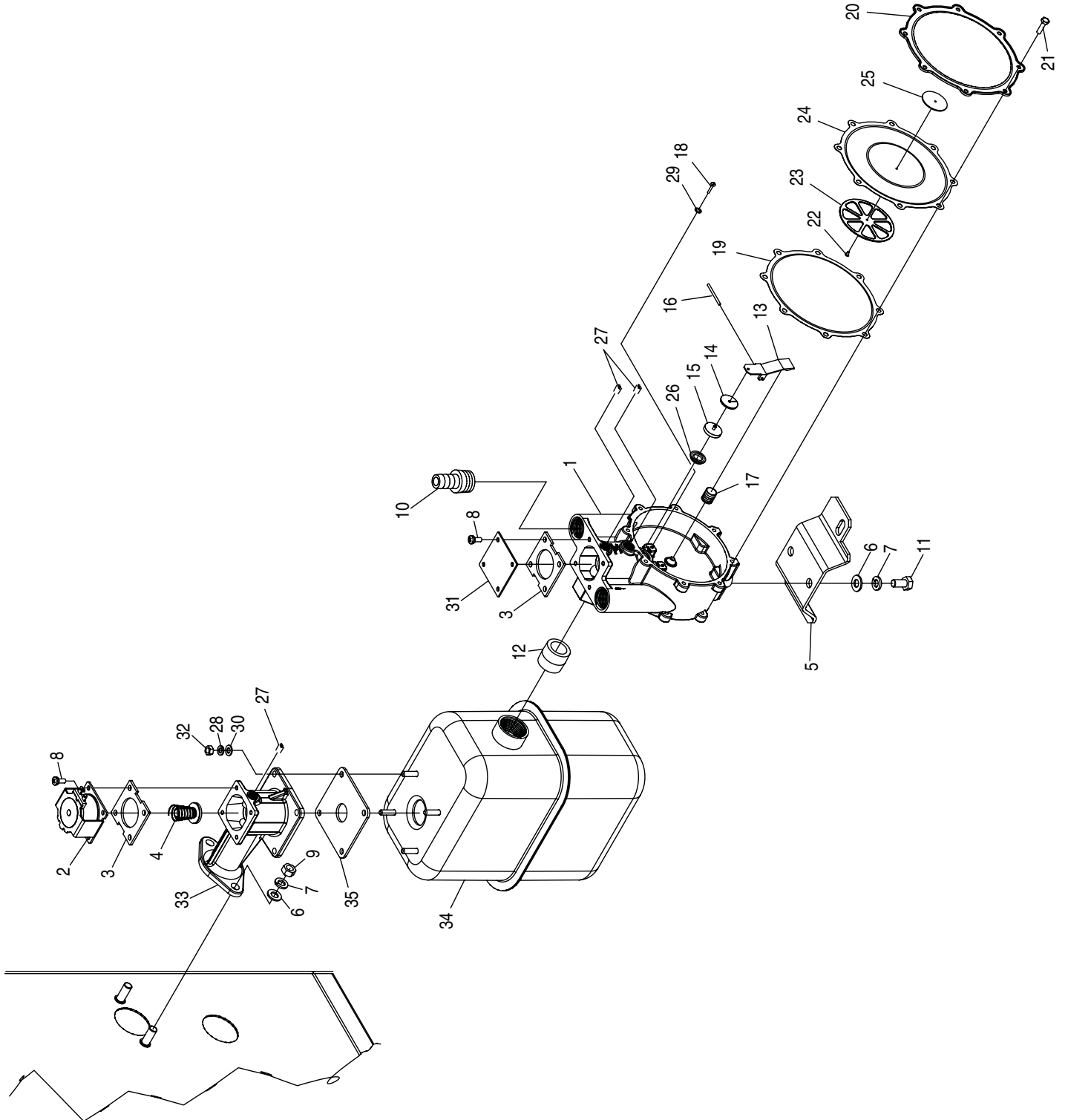

## Section 9 – Exploded Views and Parts Lists

### Air-cooled Generators 13 & 16kW, GT-990 Regulator – Drawing No. 0F9426

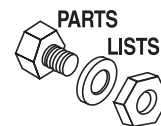

ITEM	PART NO.	QTY.	DESCRIPTION
1	0F9285	1	CASTING, TWIN REGULATOR HOUSING
2	0F5022	1	SOLENOID COIL, 12VDC
3	0C4647	2	GASKET , SOLENOID
4	0D4166	1	PLUNGER, LP REGULATOR ASSEMBLY
5	0F8096	1	BRKT REGULATOR MOUNTING 990
6	022145	4	WASHER FLAT 5/16-M8
7	022129	4	WASHER LOCK 5/16-M8
8	0F4795	8	SCREW PPHM SEMS M4-0.7 X 10
9	045771	2	NUT HEX M8-1.25
10	0C6606	2	BARBED STRAIGHT ½ NPT x ½
11	042907	2	SCREW HHC M8-1.25 X 16
12	026915A	1	NIPPLE CLOSE ¾ X 1.375 WITH VIBRA SEAL
13	0C5761	2	LEVER, REGULATOR
14	0C5968	2	SUPPORT, INLET SEAL
15	0C6066	2	SEAL, INLET
16	0C5759	2	PIN, PIVOT ARM
17	0C5764	2	SPRING, REGULATOR
18	070728	4	SCREW, PFHMS M3-0.5 x 5
19	0C6069	2	GASKET, DIAPHRAGM
20	0F9189	2	COVER, TWIN REGULATOR
21	045764	16	SCREW, TAPTITE M4X8 BP
22	0C6731	2	RIVET, POP .118 X .125
23	0C6067	2	SUPPORT, DIAPHRAGM
24	0C4706	2	DIAPHRAGM, TWIN REGULATOR
25	0C6068	2	CAP, DIAPHRAGM SUPPORT
26	0C4643A	2	INLET, TWIN REGULATOR 11.11 DIA.
27	072683A	3	PLUG STD PIPE 1/8 SOCKET HEAD
28	049226	4	WASHER, LOCK, M5
29	0D3308	4	WASHER, FLAT M3 X 10mm O.D.
30	051713	4	WASHER, FLAT, M5
31	0F8979	1	SOLENOID COVER PLATE
32	051716	4	NUT HEX M5-0.8
33	0E9533	1	SOLENOID ADAPTER
34	0E9534	1	ASSY, FUEL SYSTEM PLENUM
35	0E9535	1	PLENUM GASKET



## Section 10 – Warranty

### Air-cooled Generators

**NOTE: This Emission Control Warranty Statement pertains to this product only IF the generator size is 15 kW or below.**

## CALIFORNIA EMISSION CONTROL WARRANTY STATEMENT

### YOUR WARRANTY RIGHTS AND OBLIGATIONS

The California Air Resources Board (CARB) and Generac Power Systems, Inc. (Generac) are pleased to explain the Emission Control System Warranty on your new engine.\* In California, new utility, and lawn and garden equipment engines must be designed, built and equipped to meet the state's stringent anti-smog standards. Generac will warrant the emission control system on your engine for the periods of time listed below provided there has been no abuse, neglect, unapproved modification or improper maintenance of your engine.

Your emission control system may include parts such as the carburetor, ignition system and exhaust system. Generac will repair your engine at no cost to you for diagnosis, replacement parts and labor, should a warrantable condition occur.

### MANUFACTURER'S EMISSION CONTROL SYSTEM WARRANTY COVERAGE:

Emissions control systems on 1995 and later model year engines are warranted for two years as hereinafter noted. If, during such warranty period, any emission-related component or system on your engine is found to be defective in materials or workmanship, repairs or replacement will be performed by a Generac Authorized Warranty Service Facility.

### PURCHASER'S/OWNER'S WARRANTY RESPONSIBILITIES:

As the engine purchaser/owner, you are responsible for the completion of all required maintenance as listed in your factory supplied *Owner's Manual*. For warranty purposes, Generac recommends that you retain all receipts covering maintenance on your engine. However, Generac cannot deny warranty solely due to the lack of receipts or for your failure to ensure the completion of all scheduled maintenance.

As the engine purchaser/owner, you should, however, be aware that Generac may deny any and/or all warranty coverage or responsibility if your engine, or a part/component thereof, has failed due to abuse, neglect, improper maintenance or unapproved modifications, or the use of counterfeit and/or "grey market" parts not made, supplied or approved by Generac.

**You are responsible for contacting a Generac Authorized Warranty Service Facility as soon as a problem occurs.** The warranty repairs should be completed in a reasonable amount of time, not to exceed 30 days.

Warranty service can be arranged by contacting either your selling dealer or a Generac Authorized Warranty Service Facility. To locate the Generac Authorized Warranty Service Facility nearest you, call our toll-free number:

**1-800-333-1322**

**IMPORTANT NOTE:** This warranty statement explains your rights and obligations under the Emission Control System Warranty (ECS Warranty), which is provided to you by Generac pursuant to California law. See also the "Generac Limited Warranties for Generac Power Systems, Inc.," which is enclosed herewith on a separate sheet, also provided to you by Generac. The ECS Warranty applies **only** to the emission control system of your new engine. If there is any conflict in terms between the ECS Warranty and the Generac Warranty, the ECS Warranty shall apply except in circumstances where the Generac Warranty may provide a longer warranty period. Both the ECS Warranty and the Generac Warranty describe important rights and obligations with respect to your new engine.

Warranty service can be performed only by a Generac Authorized Warranty Service Facility. When requesting warranty service, evidence must be presented showing the date of the sale to the original purchaser/owner.

**If you have any questions regarding your warranty rights and responsibilities, you should contact Generac at one of the following addresses:**

**For Air-cooled Product ...**

**ATTENTION WARRANTY DEPARTMENT  
GENERAC POWER SYSTEMS, INC.  
P.O. BOX 297  
WHITEWATER, WI 53190**

*Part 1*

**For Liquid-cooled Product ...**

**ATTENTION WARRANTY DEPARTMENT  
GENERAC POWER SYSTEMS, INC.  
211 MURPHY DRIVE  
EAGLE, WI 53119**



### EMISSION CONTROL SYSTEM WARRANTY

Emission Control System Warranty (ECS Warranty) for 1995 and later model year engines:

- (a) Applicability: This warranty shall apply to 1995 and later model year engines. The ECS Warranty Period shall begin on the date the new engine or equipment is purchased by/delivered to its original, end-use purchaser/owner and shall continue for 24 consecutive months thereafter.
- (b) General Emissions Warranty Coverage: Generac warrants to the original, end-use purchaser/owner of the new engine or equipment and to each subsequent purchaser/owner that each of its engines is ...
  - (1) Designed, built and equipped so as to conform with all applicable regulations adopted by the CARB pursuant to its authority, and
  - (2) Free from defects in materials and workmanship which, at any time during the ECS Warranty Period, may cause a warranted emissions-related part to fail to be identical in all material respects to the part as described in the engine manufacturer's application for certification.
- (c) The ECS Warranty only pertains to emissions-related parts on your engine, as follows:
  - (1) Any warranted, emissions-related parts that are not scheduled for replacement as required maintenance in the *Owner's Manual* shall be warranted for the ECS Warranty Period. If any such part fails during the ECS Warranty Period, it shall be repaired or replaced by Generac according to Subsection (4) below. Any such part repaired or replaced under the ECS Warranty shall be warranted for the remainder of the ECS Warranty Period.
  - (2) Any warranted, emissions-related part that is scheduled only for regular inspection as specified in the *Owner's Manual* shall be warranted for the ECS Warranty Period. A statement in such written instructions to the effect of "repair or replace as necessary" shall not reduce the ECS Warranty Period. Any such part repaired or replaced under the ECS Warranty shall be warranted for the remainder of the ECS Warranty Period.
  - (3) Any warranted, emissions-related part that is scheduled for replacement as required maintenance in the *Owner's Manual* shall be warranted for the period of time prior to the first scheduled replacement point for that part. If the part fails prior to the first scheduled replacement, the part shall be repaired or replaced by Generac according to Subsection (4) below. Any such emissions-related part repaired or replaced under the ECS Warranty shall be warranted for the remainder of the ECS Warranty Period prior to the first scheduled replacement point for such emissions-related part.
  - (4) Repair or replacement of any warranted, emissions-related part under this ECS Warranty shall be performed at no charge to the owner at a Generac Authorized Warranty Service Facility.
  - (5) When the engine is inspected by a Generac Authorized Warranty Service Facility, the owner shall not be held responsible for diagnostic costs if the repair is deemed warrantable.
  - (6) Generac shall be liable for damages to other original engine components or approved modifications proximately caused by a failure under warranty of any emission-related part covered by the ECS Warranty.
  - (7) Throughout the ECS Warranty Period, Generac shall maintain a supply of warranted emission-related parts sufficient to meet the expected demand for such emission-related parts.
  - (8) Any Generac authorized and approved emission-related replacement part may be used in the performance of any ECS Warranty maintenance or repairs and will be provided without charge to the owner. Such use shall not reduce Generac ECS Warranty obligations.
  - (9) Unapproved, add-on, modified, counterfeit and/or "grey market" parts may not be used to modify or repair a Generac engine. Such use voids this ECS Warranty and shall be sufficient grounds for disallowing an ECS Warranty claim. Generac shall not be held liable hereunder for failures of any warranted parts of a Generac engine caused by the use of such an unapproved, add-on, modified, counterfeit and/or "grey market" part.

### EMISSION RELATED PARTS INCLUDE THE FOLLOWING:

- 1) Fuel Metering System:
  - 1.2) LPG/Natural Gas carburetion assembly and its internal components.
    - a) Fuel controller (if so equipped)
    - b) Mixer and its gaskets (if so equipped)
    - c) Carburetor and its gaskets (if so equipped)
    - d) Primary gas regulator (if so equipped)
    - e) LP liquid vaporizer (if so equipped)
- 2) Air Induction System including:
  - a) Intake pipe/manifold
  - b) Air cleaner
- 3) Ignition System including:
  - a) Spark plug
  - b) Ignition module
- 4) Catalytic Muffler Assembly (if so equipped) including:
  - a) Muffler gasket
  - b) Exhaust manifold
- 5) Crankcase Breather Assembly including:
  - a) Breather connection tube

\*Generac engine types covered by this warranty statement include the following:

- 1) Prepackaged Standby Generator
- 2) Auxiliary Power Unit (APU) Generator
- 3) Standby Generator



## Section 10 – Warranty

### Air-cooled Generators

#### **GENERAC POWER SYSTEMS "TWO YEAR" LIMITED WARRANTY FOR GUARDIAN® "PREPACKAGED EMERGENCY AUTOMATIC STANDBY GENERATORS"**

For a period of two years from the date of original sale, Generac Power Systems, Inc. (Generac) warrants that its Guardian generator will be free from defects in material and workmanship for the items and period set forth below. Generac will, at its option, repair or replace any part which, upon examination, inspection and testing by Generac or a Guardian Authorized Warranty Service Dealer, is found to be defective. Any equipment that the purchaser/owner claims to be defective must be examined by the nearest Guardian Authorized Warranty Service Dealer. All transportation costs under the warranty, including return to the factory, are to be borne and prepaid by the purchaser/owner. This warranty applies only to Generac Guardian prepackaged emergency automatic standby generators sold and rated for use in "Standby" applications.

#### **WARRANTY SCHEDULE**

YEARS ONE and TWO - 100% (one hundred percent) transferable coverage on Labor and Part(s) listed (proof of purchase and maintenance is required):

Engine - All Components

Alternator - All Components

Transfer System - All Components

Steel enclosures are warranted against rusting for the first year of ownership only. Damage caused after receipt of generator is the responsibility of the owner and is not covered by this warranty. Nicks, scrapes, dents or scratches to the painted enclosure should be repaired promptly by the owner.

All warranty expense allowances are subject to the conditions defined in Guardian's Warranty Policies, Procedures and Flat Rate Manual.

#### **THIS WARRANTY SHALL NOT APPLY TO THE FOLLOWING:**

- Guardian generators that utilize non-Guardian/Generac replacement parts.
- Guardian generators utilizing non-Guardian/Generac automatic transfer switches.
- Repairs or diagnostics performed by individuals other than Guardian/Generac authorized dealers not authorized in writing by Generac Power Systems.
- Any Guardian generators used as rental or trailer mounted applications.
- Damage to generator system (including transfer switch) caused by improper installation or costs necessary to correct installation.
- Units used for prime power in place of existing utility power where utility power is present or in place of utility power where utility power service does not normally exist.
- Costs of normal maintenance, adjustments, installation and start-up.
- Steel enclosures that are rusting due to the improper installation, location in a harsh or saltwater environment or scratched where integrity of paint applied is compromised.
- Failures caused by any contaminated fuels, oils, coolants or lack of proper fluid amounts.
- Failures due, but not limited, to normal wear and tear, accident, misuse, abuse, negligence or improper installation. As with all mechanical devices, the Generac engines need periodic part(s) service and replacement to perform well. This warranty will not cover repair when normal use has exhausted the life of a part(s) or engine.
- Failures caused by any external cause or act of God, such as collision, theft, vandalism, riot or wars, nuclear holocaust, fire, freezing, lightning, earthquake, windstorm, hail, volcanic eruption, water or flood, tornado or hurricane.
- Damage related to rodent and/or insect infestation.
- Products that are modified or altered in a manner not authorized by Generac in writing.
- Any incidental, consequential or indirect damages caused by defects in materials or workmanship, or any delay in repair or replacement of the defective part(s).
- Failure due to misapplication.
- Telephone, cellular phone, facsimile, internet access or other communication expenses.
- Living or travel expenses of person(s) performing service, except as specifically included within the terms of a specific unit warranty period.
- Expenses related to "customer instruction" or troubleshooting where no manufacturing defect is found.
- Rental equipment used while warranty repairs are being performed.
- Costs incurred for equipment used for removal and/or reinstallation of generator, (i.e.; cranes, hoists, lifts, etc.)
- Overnight freight costs for replacement part(s).
- Overtime labor.
- Starting batteries, fuses, light bulbs and engine fluids.

THIS WARRANTY IS IN PLACE OF ALL OTHER WARRANTIES, EXPRESSED OR IMPLIED. SPECIFICALLY, GENERAC MAKES NO OTHER WARRANTIES AS TO THE MERCHANTABILITY OR FITNESS FOR A PARTICULAR PURPOSE. Some states do not allow limitations on how long an implied warranty lasts, so the above limitation may not apply to you.

GENERAC'S ONLY LIABILITY SHALL BE THE REPAIR OR REPLACEMENT OF PART(S) AS STATED ABOVE. IN NO EVENT SHALL GENERAC BE LIABLE FOR ANY INCIDENTAL OR CONSEQUENTIAL DAMAGES, EVEN IF SUCH DAMAGES ARE A DIRECT RESULT OF GENERAC'S NEGLIGENCE. Some states do not allow the exclusion or limitation of incidental or consequential damages, so the above limitation may not apply to you.

This warranty gives you specific legal rights. You also have other rights from state to state.

**GENERAC® POWER SYSTEMS, INC.  
P.O. BOX 297 · WHITEWATER, WI 53190**

Revision (09/01/06)