

# Electrical Handbook

## 2008-2009 Edition

**Note:** This CD requires Adobe Acrobat Reader 7.0 or higher in order to display and search correctly. You should see a search panel at right, and links should have a simple underline rather than a box. If you are using an earlier version of Acrobat Reader, go to <http://www.adobe.com/products/acrobat/readstep2.html> for a free download of the latest version.

CLICK ANYWHERE on THIS PAGE to RETURN to

ELECTRIC MOTOR DIAGNOSTIC GUIDE at [InspectApedia.com](http://InspectApedia.com)

### FOREWORD

The progress of Emerson Climate Technologies, Inc., as well as that of refrigeration and air conditioning in general, has been greatly aided by good field service. Everyone at Emerson Climate Technologies, Inc. recognizes and appreciates the important contribution of the service engineer upon whose talents we and all refrigeration equipment manufacturers depend to assure complete user satisfaction.

This booklet covers in detail electrical service information on welded compressors, Copelametic®, Copeland Scroll®, and Copeland Screw™ compressors. In addition, electrical service information is provided for Copeland® Condensing Units. The booklet is designed to assist the service engineer to better understand the function of such items as motors, relays, starting capacitors, running capacitors and motor protectors. In addition to electrical information, a brief section dealing with diagnosing the causes of compressor failures has been added.

### TABLE OF CONTENTS

<b><u>Motors and Electrical Components</u></b> .....	A
• Single and Three Phase Motors	
• Capacitors	
• Measuring Motor Temperature	
• Measuring Winding Resistance	
<b><u>Electrical Motor Protection</u></b> .....	B
<b><u>Fuse Selection</u></b> .....	C
<b><u>Compressor Nomenclature</u></b> .....	D
• Welded Compressors	
• HFC Welded Compressors	
• A-Line	
• CRKQ, CIKQ	
• CR7, CR6, CRKF, CS, CF	
• Coplematic®	
• Copeland Discus™	
• Refrigeration Copeland Scroll®	
• A/C Copeland Scroll®	
• Condensing Unit (All models except M-Line)	
• M-Line Condensing Unit	
• Copeland Screw™	
<b><u>Electrical Component Nomenclature and Data</u></b> .....	E
• Potential Relay Nomenclature	
• G.E. Numbering System	
• Potential Relay Data	
• Current Relay Data	
• Start Capacitor Data	
• Run Capacitor Data	
<b><u>Compressor Electrical Data</u></b> .....	F
• <b><u>A-Line</u></b> .....	FA
• <b><u>Welded Compressors</u></b> .....	FB
• <b><u>Copelametic® Air-Cooled</u></b> .....	FC
• <b><u>Copelametic® Small Refrigerant-Cooled</u></b> .....	FD
• <b><u>Copelametic® Large Refrigerant-Cooled</u></b> .....	FE
• <b><u>Copeland Scroll®</u></b> .....	FF
• <b><u>Copeland Screw™</u></b> .....	FG
<b><u>Wiring Diagrams</u></b> .....	G
<b><u>Electrical Troubleshooting Procedures</u></b> .....	H
<b><u>Identifying Compressors Failures</u></b> .....	I

## SECTION A

### MOTORS AND ELECTRICAL COMPONENTS

#### TOPICS

Single Phase Motors .....	A2
Start Relays .....	A3
Start Capacitors.....	A5
Run Capacitors.....	A7
Parallel and Series Capacitors .....	A9
Measuring Motor Temperature .....	A10
Measuring Winding Resistance.....	A11
Resistance Measurements for Single Voltage Motors.....	A13
Resistance Measurements for Dual Voltage Motors .....	A15

### SINGLE PHASE MOTORS

There are four basic types of single phase motors used in hermetic and semi-hermetic compressors:

- Split Phase or Resistance start - Induction Run (RSIR)
- Capacitor Start - Induction Run (CSIR)
- Capacitor Start - Capacitor Run (CSCR)
- Permanent Split Capacitor (PSC)
- Schematic diagrams of each type are shown in Figures 1,2,3 and 6

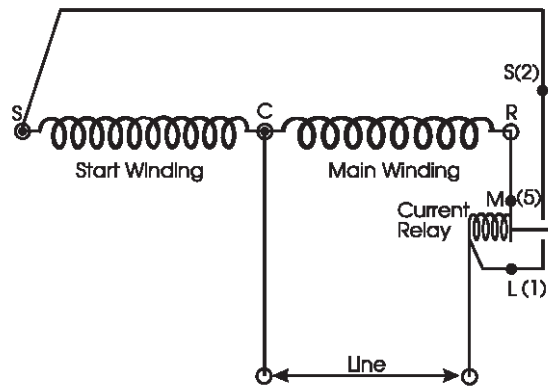

**Split Phase Motor**

**Figure 1**

A2

### START RELAYS

Current and potential relays are used to actuate components that provide the torque to start single phase motors.

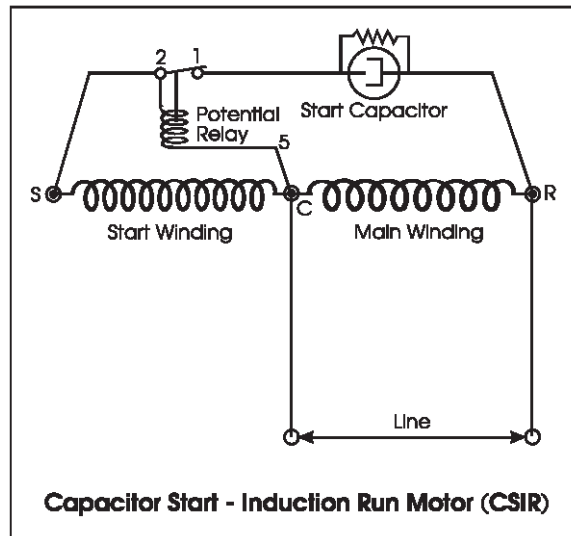

Figure 2



### **The Current Relay**

Current relays are used on small fractional horsepower compressor motors. The current relay contacts are normally open when de-energized. Its coil is wound with heavy wire and is placed in series with the incoming power line (Figure 1). The connections to the current relay are L, M, and S. Alternate connections are 1,5, and 2. When the compressor is energized inrush currents pass through the current relay coil, and its contacts close and connect the start winding to the motor circuit. The start winding is wound with a higher resistance than the run winding. This changes its phase current with respect to the run winding and produces the torque required for motor starting. The relay's contacts open when current drops as the compressor comes up to speed, and the start winding is disconnected from the motor circuit.

### **The Potential Relay**

The potential (voltage sensing) relay places the start capacitor in series with the start winding. It does so by sensing voltage across the start winding, rather than line current as does the current relay.

The contacts of the potential relay are normally closed (Figures 2, and 3), and the start capacitor is connected to the start winding as soon as power is applied to the compressor motor. The relay's coil senses the voltage developed across the start winding. It is designed to pick up, open its contacts, and disconnect the start capacitor from the start winding, when sufficient voltage is generated. Since the voltage or back-EMF generated by the start winding is proportional to motor speed, the relay will open only when the motor has started and is approaching normal running speed.

A4

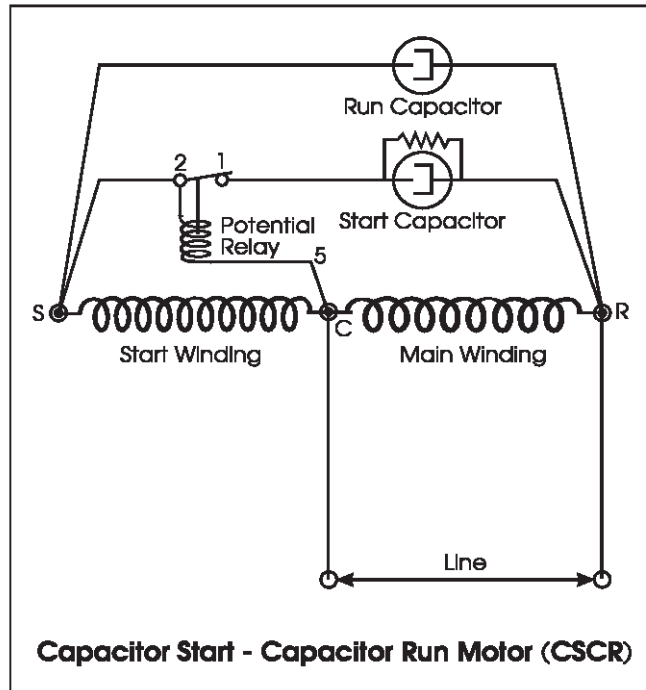
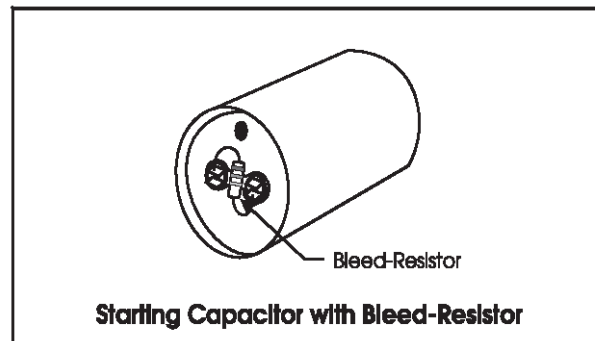

Figure 3

**START CAPACITORS**

Start capacitors are used on compressors where system designs require high starting torque. Start capacitors are designed for intermittent service only and have a high microfarad (MFD) rating. Their construction is of the electrolytic type in order to obtain high capacitance.

All standard Copeland® start capacitors are supplied with bleed-resistors securely attached and soldered to their terminals as shown in Figure 4.



**Figure 4**

The use of capacitors without these resistors will result in sticking relay contacts and/or erratic relay operation especially where short cycling is likely to occur. This is due to the start capacitor discharging through the relay contacts as they close, following a very short running cycle. The resistor permits the capacitor charge to bleed down at a much faster rate, preventing arcing and overheating of the relay contacts.

The use of capacitors supplied by Emerson Climate Technologies, Inc. is recommended. In case of an emergency exchange, a 15,000-18,000 ohm, two watt resistor should be soldered across the terminals of each start capacitor. Care should be taken to prevent their shorting to the case or other nearby metallic objects.

If sticking contacts are encountered on any start relay, the first item to check is the start capacitor resistor. If damaged, or not provided, install a new resistor, and clean the relay contacts or replace the relay. Suitable resistors can be obtained from any electronic parts wholesaler or retailer.

A6

### **RUN CAPACITORS**

Run capacitors are used on compressors to improve efficiency, raise the motor's power factor, and lower noise. Run capacitors are continuously in the operating circuit and are normally of the metallized film type. They are manufactured in oval (Figure 5) or round cans.

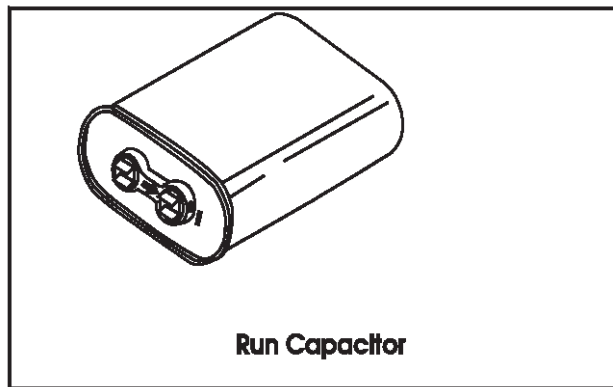

**Figure 5**

### **THE PTC START ASSIST**

The PTC (Positive Temperature Coefficient) resistor is used for applications where high starting torque is not required. The PTC resistor is connected in parallel with the run capacitor, placing it in series with the start winding (Figure 6). The PTC has a low resistance when it is cold. When the motor starts, the low resistance causes a large current to flow through the resistor. The current drawn by the resistor is out of phase with the current drawn by the motor windings, and this provides the torque to start. As soon as the resistor draws current, it begins to heat, and the positive temperature effect of the resistor causes it to rapidly increase its resistance. By the time the motor reaches full speed, very little current is drawn by the re-

A7

sistor. Although it remains connected to the motor circuit, it has no significance in the operation of the compressor.

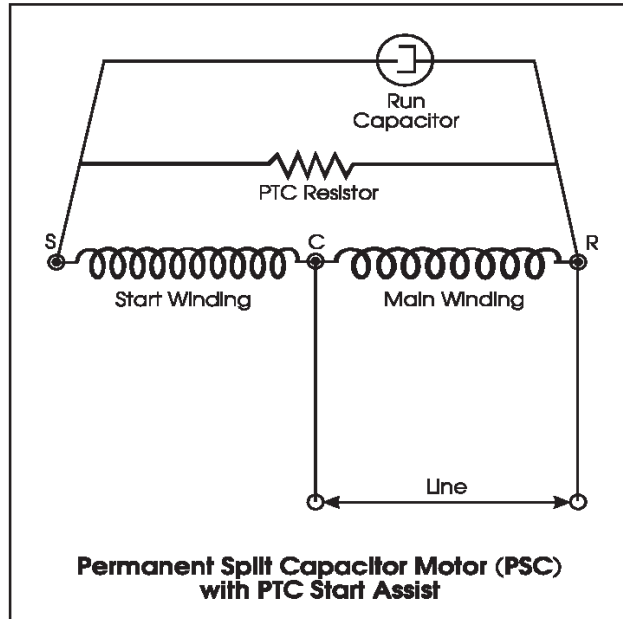

Figure 6

### Capacitor Voltage

The voltage rating of a capacitor indicates the highest nominal voltage at which it is designed to operate. Use of a capacitor at voltages below its rating will do no harm. Run capacitors must not be subject to voltages exceeding 10 percent of the nominal rating, and start capacitors must not be subjected to voltages exceeding 30 percent of the nominal rating.

A8

The voltage to which a capacitor is subjected is not line voltage, but is a much higher potential (often called back electromotive force or back EMF) which is generated in the start winding. On a typical 230 volt motor, the generated voltage may be as high as 400 volts and is determined by the start winding characteristics, the compressor speed, and the applied voltage.

### PARALLEL AND SERIES CAPACITORS

Capacitors, either start or run, can be connected in series or parallel to provide the desired characteristics if the voltage and MFD are properly selected. When two capacitors having the same MFD rating are connected in series, the resulting total capacitance will be one half the rated capacitance of a single capacitor. The formula for determining capacitance (MFD) when capacitors are connected in a series is as follows:

$$\frac{1}{MFD_t} = \frac{1}{MFD_1} + \frac{1}{MFD_2}$$

For example, if a 20 MFD and a 30 MFD capacitor are connected in series, the resultant capacitance will be:

$$\frac{1}{MFD_t} = \frac{1}{20} + \frac{1}{30}$$

$$\frac{1}{MFD_t} = \frac{3}{60} + \frac{2}{60} = \frac{1}{12}$$

$$MFD_t = 12MFD$$

The voltage rating of similar capacitors connected in series is equal to the sum of the voltage of the two capacitors. However, since the voltage across individual capacitors in series will vary with the rating of the capacitor, for emergency field replacements, it is recommended that only capacitors of like voltage and capacitance be connected in series to avoid the possibility of damage due to voltage beyond the capacitor limits.

When capacitors are connected in parallel, their MFD rating is equal to the sum of the individual capacitances. The voltage rating is equal to the lowest voltage rating of the individual capacitors.

It is possible to use any combination of single, series, or parallel start capacitors, with single or parallel run capacitors (run capacitors are seldom used in series).

#### **MEASURING MOTOR TEMPERATURE**

During system engineering development or in attempting to evaluate the ability of a compressor motor to operate under severe conditions, it is often desirable to measure motor temperatures under extreme conditions. In the laboratory during compressor development, temperature measurements of this type are made by means of thermocouples embedded in the motor windings with the leads brought out through gasketed surfaces. In evaluating a production compressor in a system, thermocouple readings are not usually feasible, and the only means of checking motor temperatures is by checking resistance values.

The resistance through the motor windings varies in a ratio to the change in winding temperature. By establish-

A10

ing a base resistance value at a given base temperature (normally room temperature after storage for a prolonged period without operation) any change in the temperature of the motor windings can be calculated by determining the change in winding resistance. The resistance method, since it reads the overall resistance of the winding, is an average reading and does not accurately reflect the temperature that might exist at hot spots. In some cases, there may be hot spots that can reach temperatures of 40°F or more above the average reading so resistance readings must be evaluated very conservatively.

Motors may be wound with either copper or aluminum wire, and it is necessary to know the motor construction since the resistance change varies depending on the type of wire. The basic formula for calculating winding temperature is as follows:

$$T_h = \frac{R_h}{R_c} (T_c + K) - K$$

Th = Temperature hot

Tc = Temperature cold

Rh = Resistance hot (ohms)

Rc = Resistance cold (ohms)

Kcopper = 390.1 for °F, 234.5 for °C

Kaluminum = 365.8 for °F, 221.0 for °C

### MEASURING WINDING RESISTANCE

DISCONNECT ALL SOURCES OF POWER TO THE COMPRESSOR BEFORE MAKING ANY RESISTANCE MEASUREMENT



### **Compressor Wiring Diagrams**

Compressor wiring diagrams with motor winding connections and numbering are often used as a reference for compressor motor winding resistance measurements.

*Electrical Handbook* wiring diagrams show the compressor motor with its windings connected for its design voltages. The compressor motor windings are also shown **unwired** and labeled so that if it is necessary, **individual winding resistances can be measured and compared to each other.**

The pages of Section G of the *Electrical Handbook* that are headed **Copelametic Wiring Diagrams** and **Welded Compressors Wiring Diagrams** list applicable wiring diagrams. They are indexed by the portion of the Copeland® compressor model number that references:

1. Compressor Model
2. The Compressor Electrical Characteristics: the type of motor, type of overload protection, voltage and phase.

A typical compressor model number **4DH3R22ME-TSK** indicates a **4D** Compressor Model with **TSK** Compressor Electrical Characteristics (see Section D of the *Electrical Handbook* for further compressor model nomenclature).

### **Ohmmeter Resistance Measurements.**

*Electrical Handbook* (See Section F) pages designated **Electrical Data-Copelametic Compressors, Electrical Data-Copeland Scroll Compressors, and Electrical Data-Welded Compressors** have columns that are headed Winding Resistance (Ohms).

A12

The resistances shown are compressor motor resistances measured when the motor is **connected** for the voltage shown in the **Electrical Data** column headed **Volts**. Measurements must be taken with **all external connections** removed from the winding terminal blocks, but **winding connection jumpers** (if system voltage has been selected) **inplace**. Resistance measurements should be within plus or minus 10% of the listed resistance.

The most satisfactory instrument for all winding resistance measurements is a low range digital ohmmeter since many of the winding resistances listed are in fractions of an ohm.

**MEASURING RESISTANCES OF SINGLE VOLTAGE RANGE MOTORS** (Single Phase and Three Phase)  
Measurements are straightforward for single phase and three phase compressors that can **only be wired across the line for a single voltage**.

1. Single phase motors have a Start Winding, a Run Winding, and a Common connection between them. Therefore, the measurements are listed as: Start Winding: "C" (Common) to "S" (Start), and Run Winding: "C" (Common) to "R" (Run). See Figure 7.

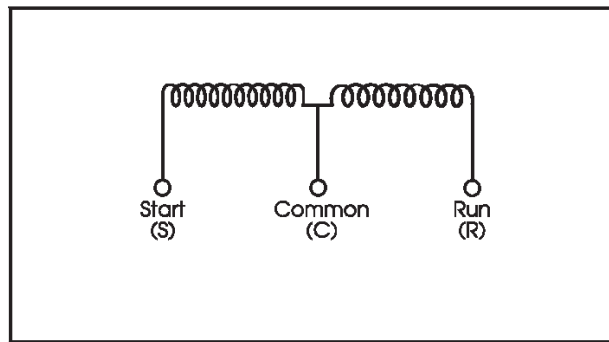

**Figure 7**

2. On Three phase motors having a single voltage range the resistance measured is actually **twice** that of an individual winding since the centers of 3 lead, **Wye** wound motors are internally connected and cannot be reached for measurement. See Figure 8.

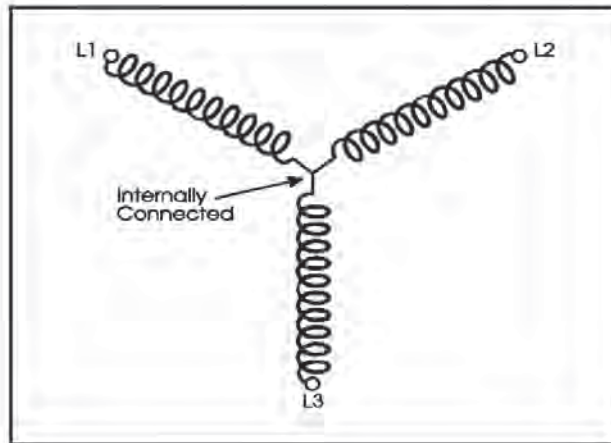
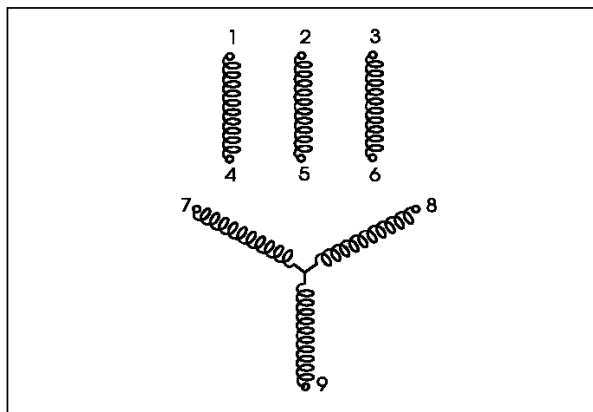

Figure 8

**MEASURING RESISTANCES AND ELECTRICAL CONNECTIONS OF DUAL VOLTAGE THREE PHASE MOTORS (Single Contactor and Part-Winding or Two Contactor)**

The resistances listed in Section F, under the column headed **WINDING RESISTANCE IN OHMS, LINE TO LINE** are the values for a one contactor, **across-the-line start**. When a six or nine lead motor is connected for a two contactor part winding start or across-the-line start, the phase-to-phase ohm value will be twice (x2) the value listed. When a nine lead motor is connected for high voltage, 460 volts, the phase-to-phase ohm value will be four times (x4) the listed value of the 230 volt value. If individual resistance measurements are needed, for a nine-lead motor, disconnect all jumpers and refer to Figure 9.

There are three individual windings (1-4, 2-5, and 3-6) and one wye-connected winding (7-8-9). The individual winding resistances are equal to the compressor's 230 volt connected resistance measurement of Section F. The wye winding value is twice the 230 volt resistance measurement of Section F.



**Figure 9**

Electrical connections are made through contactors to the compressor motor terminals. Brass jumper bars must be connected to the motor terminals to allow one or two contactors to be used for either across-the-line or part-winding starts. If the windings are connected out of phase, in any application, or if the jumper bars are not positioned correctly, motor overheating and failure will occur.

A16

Six-lead motors are single voltage motors such as 200 or 460 volts. Nine-lead motors are dual voltage motors such as 208-230/460 volts.

Figure 10 shows the electrical connections for a six lead 200 or 460 volt single contactor application.

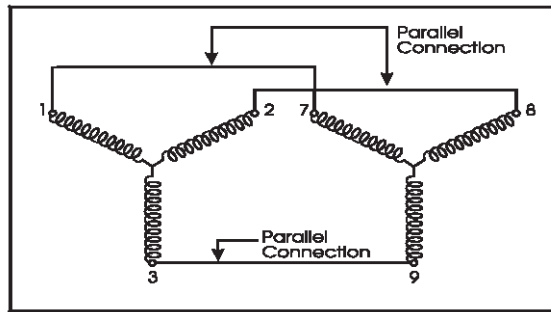

**Figure 10**

Figure 11 shows the electrical connections for a six lead 200 or 460 volt two contactor across-the-line or part-winding start application. The dotted lines mean power connections are made electrically rather than by jumper bars.

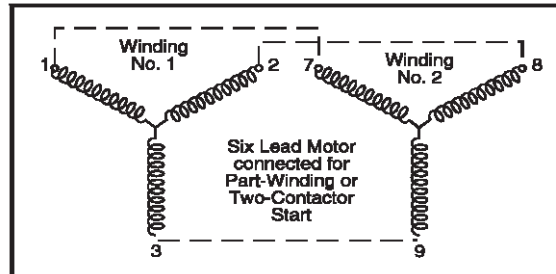

**Figure 11**

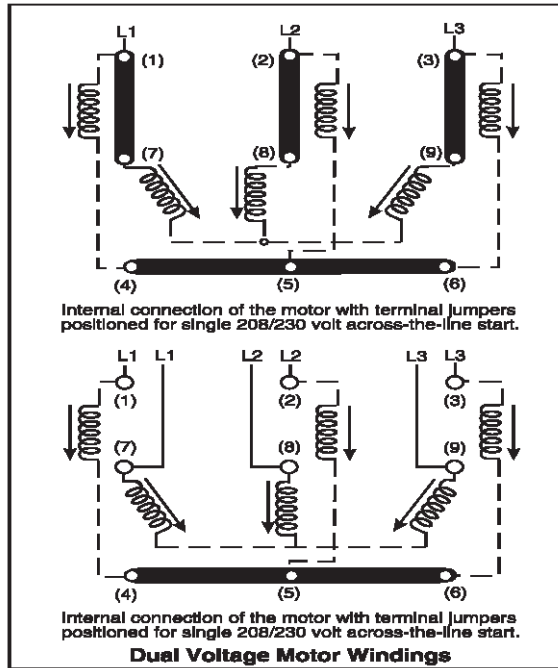
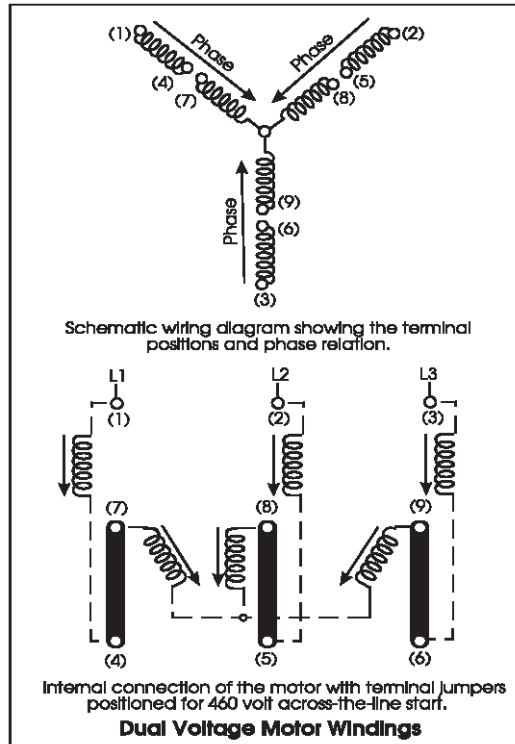

Figure 12

Figure 12 (top) shows the electrical connections for a nine lead, 208-230/460 volt, single contactor application when connected to 208 or 230 volts. It also shows (bottom) the electrical connections for a two contactor application when connected to 208 or 230 volts for an across-the-line or part-winding start.



**Figure 13**

Figure 13 shows the electrical connections for a nine-lead 208-230/460 volt single contactor application when connected to 460 volts.

Part-winding starts require a time delay relay. The time delay relay used in a part-winding start application, for either six- or nine-lead motors, must have a one second



delay and must be used between the pull in of the first and second contactors. Part-winding contactors must be sized based on the compressor motor Rated Load Amps (RLA) **and** the Part Winding Start, Locked Rotor Amp (LRA) rating. See Section F.

#### **Measurements Using The Megohmmeter or “MEGGER”**

When using a megohmmeter to evaluate the motor insulation of compressors, it is important to understand that they are not intended to be used for a single reading. They were developed to establish a trend. In other words, “meggers” are best used as part of a regular maintenance program where periodic readings can be recorded and a long term insulation resistance trend established.

There are many factors that affect megohm readings including contaminated refrigerant, oil level, and current leakage through electrical fuses or terminal plates. Before making a measurement, all external wiring should be removed, and all electrical terminal bolts cleaned and torqued to specifications.

#### **Measurements Using The High Potential Or “Hi-Pot” Tester**

Ohmmeter readings usually determine if a motor is shorted or open, but a motor that has passed ohmmeter resistance checks may still have repeated overload or short circuit protector trips.

The motor may have a weakened winding that shorts to ground when the compressor is called on to run. The winding breakdown can be caused because of the system voltage applied to it, heat build up, or mechani-

A20

cal stresses. It may also have a terminal board that has developed an insulation breakdown from a terminal to ground or from a terminal to another terminal.

A “Hi-Pot” tester can be used in conjunction with an ohmmeter to check for insulation failure on both welded compressors and Copelametic compressors. The terminal board check can only be made on Copelametic compressors.

A “Hi-Pot” tester develops a **high voltage, low current** power source and is used to check for an **insulation breakdown** that the ohmmeter with its **low voltage power source** may miss. It measures winding insulation resistance to ground and (where applicable) terminal board resistance from terminal to ground and from terminal to terminal. To measure winding insulation resistance, **all wiring is removed from the motor winding terminals**. To measure terminal board resistance, **all wiring is removed from the terminal board**.

The “Hi-Pot tester” ***should never be***:

1. Operated alone or by an inexperienced service person.
2. Set at a voltage of more than twice the compressor operating voltage plus 1000 volts.
3. Be set for more than 5 milliamps without consulting Emerson Climate Technologies, Inc.
4. Applied for more than the time it takes to obtain a reading (no more than a few seconds).
5. Used as a phase-to-phase winding check.
6. Used on any other part of the compressor.
7. Used when the compressor (system) is in a vacuum.

A21

**SECTION B**  
**ELECTRONIC MOTOR PROTECTION**  
**Scroll Compressor Applications**

All Emerson Climate Technologies, Inc. Electronic Motor Protectors are manufactured by Kriwan Industries and Texas Instruments.

**Scroll Compressor Applications**

In all applications using Copeland Scroll® compressors, each protector monitors motor temperature, supply power voltage.

In all applications, utilizing the Kriwan Module, the motor temperature is monitored using 4 positive temperature coefficient sensors (PTC) wired in series. Four sensors are embedded in the motor and one is located inside the scroll set and is used to monitor the discharge gas temperature. The sensors have a positive temperature coefficient, and their resistance increases as the internal temperature of the compressor motor rises. The control module will compare the sensor resistance to a predetermined safe level; and if the total sensor resistance is too high, the module control contact opens and breaks the circuit for the contactor coil control voltage, which then opens the contactor and removes line voltage from the compressor. After a trip, when the motor has cooled to a level that allows for the sensor resistances to return to safe levels, the module will reset and close the control contacts, which will allow the motor to restart.

All motor protector modules monitor power supplied to the module and will trip if the power supplied to T1-T2 terminals are too low.

B1

In refrigeration applications using scroll compressors, each protector additionally monitors 3 phase incoming power phase rotation and phase loss. The module is continuously monitoring the phases by checking the phase sequencing. If the phase drops below a level that is detectable by the electronics, the module will detect a phase loss and will trip. The module monitors the phase angle differences between the phases.

The supply voltage can be 24VDC, 24VAC or 120/240VAC depending on the model of motor protector module. Refer to AE Bulletin AE 4-1302 and AE 4-1318 for specifications.

#### **Semi-Hermetic Compressor Applications**

In all applications using Semi-Hermetic compressors, each protector monitors motor temperature, supply power voltage.

Each protector consists of three temperature sensors (embedded in the compressor motor windings) connected to an electronic control module.

The sensors have a positive temperature coefficient, and their resistance increases as the internal temperature of the compressor motor rises. The control module compares the sensor resistance to a predetermined safe level; and if any sensor resistance is too high, the module control contact opens and breaks the circuit for the contactor coil control voltage, which then opens the contactor and removes line voltage from the compressor. After a trip, when the motor has cooled to a level that allows for the sensor resistances to return to safe levels, the module will reset and close the control contacts, which will allow the motor to restart.

B2

All motor protector modules monitor power supplied to the module and will trip (open the contacts between M1 and M2) if the power supplied to L1-L2 terminals are too low. See AE Bulletin AE 10-1264 for specifications and wiring diagrams.

### **Screw Compressor Applications**

In all applications using Screw compressors, each module monitors motor temperature, phase sequence control for direction of rotation, manual reset lock-out and oil temperature protection by PTC sensor.

In all applications, the motor temperature is monitored using nine sensors embedded into the motor windings which are in series and connected to the module. The sensors have a positive temperature coefficient and their resistance increases as the internal temperature of the compressor rises. The control module compares the sensor resistance to a predetermined safe level and if any sensor resistance is too high. The module control contact opens and breaks the circuit for the contactor coil control voltage, which then opens the contactor and removes line voltage from the compressor. After a trip, the module "must" be manually reset by interruption of the supply voltage to the module for a minimum of 2 seconds.

The other features of the module are: Direction of Rotation / Phase Sequence. When the module senses incorrect rotation or a phase sequence fault the module will immediately shutdown the compressor and lockout. After the correction of the fault, the module must be manually reset.

Oil protection by the PTC sensor. An oil sensor is installed in the oil sump of the compressor and pre-wired

B3

to the module in series with the motor windings PTC's. If the temperature of the oil rises to an unsafe condition, the compressor will shutdown.

The supply voltage can be 24VDC, 24VAC, 120volt or 220volt.

Refer to AE Bulletin AE4-1322 and/or Operating Instruction 2001-71 for specifications.

**Type Of Protection The Motor Protector Provides:**

Motor Over Temperature and Running Over Current

- It protects the compressor by opening it's control contact when it senses dangerous motor over temperatures and/or over currents, which convert to over temperatures.

Primary Single Phasing

- The protector sensors detect the sharp rise of temperature in compressor motor windings caused by the high current resulting from a transformer primary single phase condition.

Voltage Unbalance

- The protector protects against dangerous over-currents caused by system voltage unbalance.

Low Voltage Protection

- The electronic motor protector is designed so that it will not allow the compressor to start with low voltage at the protector module. When running, if the module voltage drops below operating minimums, the module control contact will immediately open and a two-minute delay before a restart is attempted. If any of these occurrences result in a dangerous motor temperature rise, the protector will immediately open it's control contact.

B4

#### Short Cycle Protection

- Since the electronic protector has been designed to provide a two-minute time delay before restart after a low voltage or no voltage condition, it can be used as protection against compressor short cycling. For short cycling protection, the compressor control circuit must be designed so the temperature or pressure controller turns the electronic protector power on and off, and the protector contact control the compressor contactor. Each time protector power is cycled, it provides a two-minute time delay before it's contact closes and restarts the compressor.

#### Phase Loss Protection

- The scroll refrigeration module and the screw module will sense the correct phase sequence of L1, L2 and L3 incoming power. The three phase power must be wired in the correct 120 degree phase sequence that will ensure the compressor will start and operate in the correct clockwise rotation.

When the module trips on phase loss, a delay of 5 minutes is activated and then there is a new attempt to restart. If all three phases are present, then the compressor will continue to run. If not the module will lock out. There can be 10 attempts to restart before the module will lock out and then only can be reset by reestablishing incoming power to the module.

#### **ELECTRONIC PROTECTOR SPECIFICATIONS:**

Low Voltage Protection

24 VAC Module (Texas Instruments)

Cut-Out Voltage is 16 volts plus or minus 1.5 volts at normal ambients.

B5

Cut-In Voltage is 2 volts higher than cut-out.

#### 120 VAC Module

Cut-Out Voltage is 85 volts plus or minus 4.5 volts at normal ambients.

Cut-In Voltage is 4 volts higher than cut-out.

#### 240 VAC Module

Cut-Out Voltage is 170 volts plus or minus 8 volts at normal ambients. Cut-In Voltage is 4 volts higher than cut-out.

For all Modules, the low Voltage Response Delay is .2 seconds plus or minus .15 seconds.

#### Off Cycle Timer

120 seconds plus or minus 15 percent at normal ambients.

#### Contact Rating

The TI (15AA) and the Kriwan (INT369) have a contact rating of 275VA for either 120 VAC or 240 VAC. The 24VAC module has a rating of 72VA.

#### Sensor Resistances

See individual protector check-out procedures.

B6



### CHECKOUT PROCEDURE FOR ROBERTSHAW MODULES MP13, 23 AND 33

**CAUTION**  
These checks have system voltage present! They should only be conducted by experienced personnel. Always have someone present when checking a compressor system.

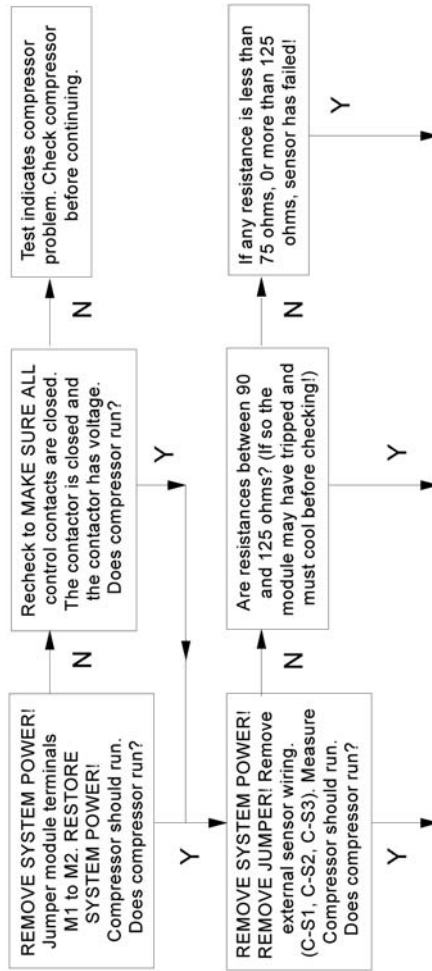

B7

B8

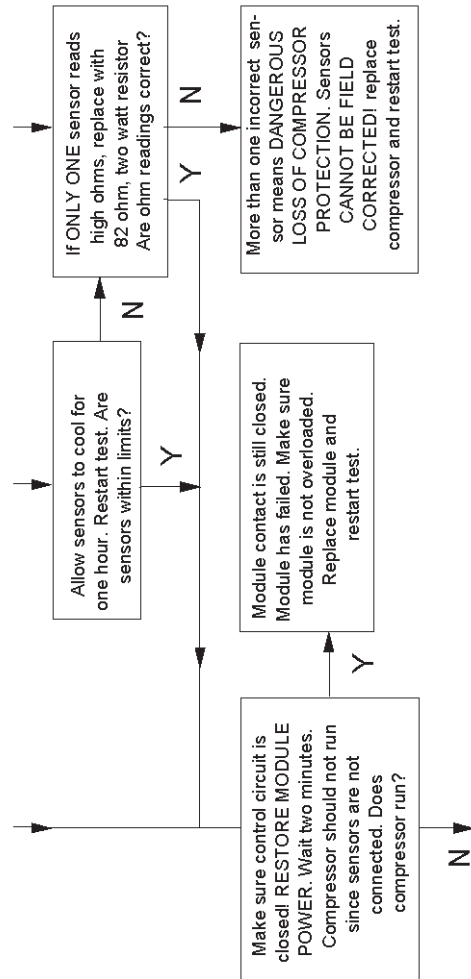

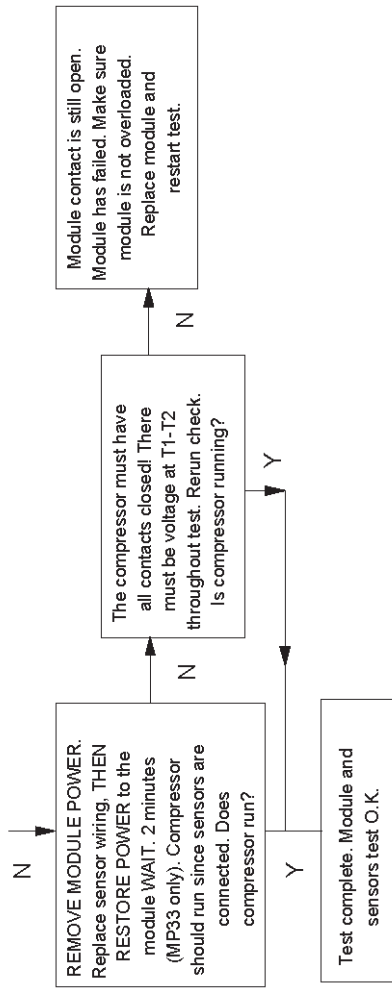

B9

### CHECKOUT PROCEDURE FOR TEXAS INSTRUMENTS 3AA, 15AA, ROBERTSHAW MP50, AND KRIWAN INT369 ELECTRONIC MODULES

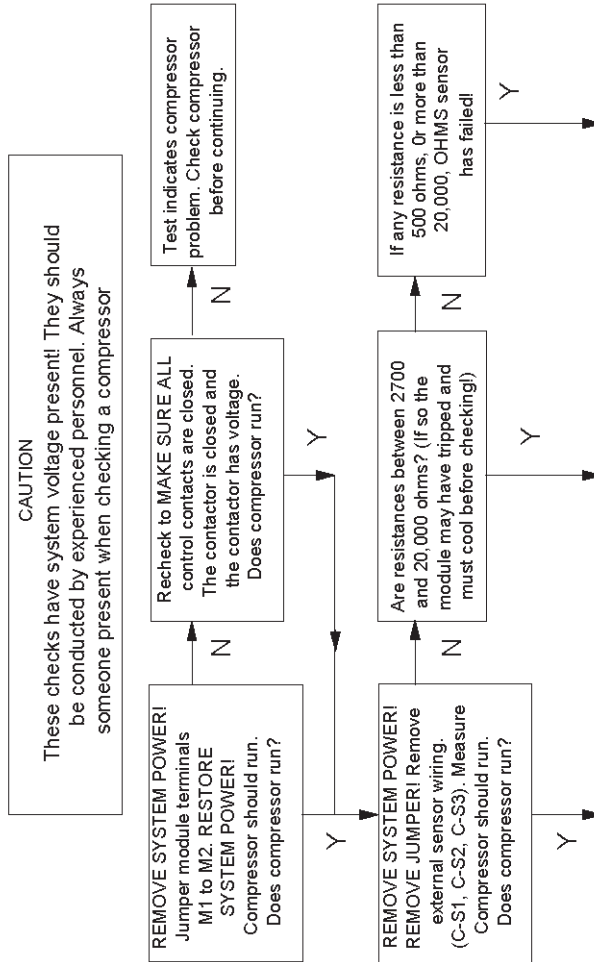

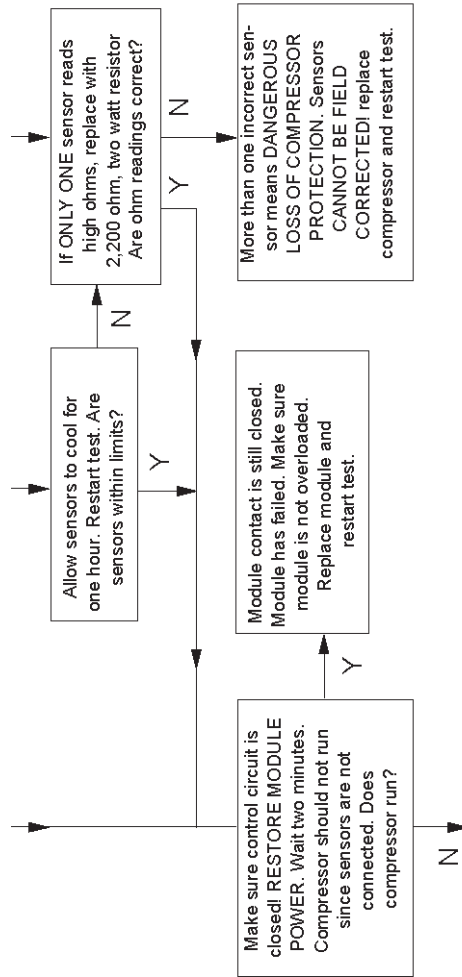

B11

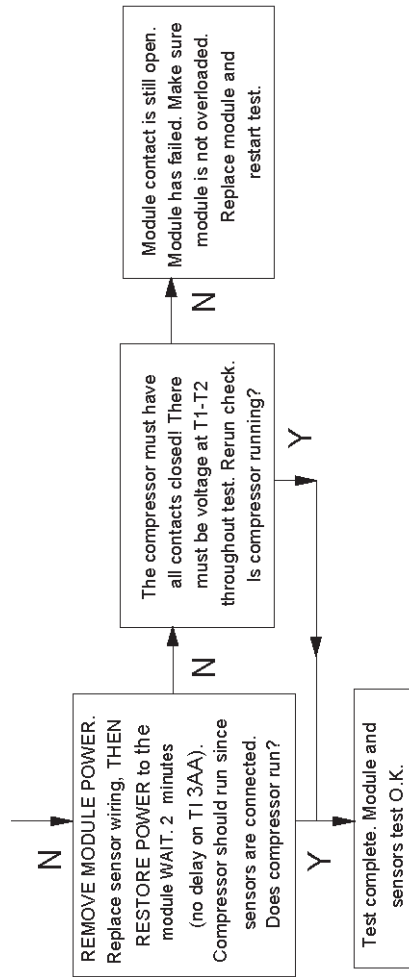

B12

## SECTION C

### FUSE SELECTION FOR WELDED COMPRESSORS AND COPELAMETIC COMPRESSORS

Motor Running Overload Protection and Branch Circuit Short Circuit Protection are required for every compressor electrical branch circuit. These are detailed in Articles 430 and 440 of The National Electrical Code (NEC). All installations and fuse selections must conform to the NEC and any specific local code requirements. In case of questions, contact a qualified electrician.

The fuse selection procedures of the Electrical Handbook are based on time delay (dual element) sizes that will meet the requirements of most compressor installations. The selections conform to the National Electrical Code short circuit requirements for single motor protection.

The manufacturer of the compressor system should be consulted in cases of multiple motor or group fusing, extreme ambient temperatures, or unusual operating conditions where a larger fuse size than recommended may be required.

Each compressor nameplate lists compressor data that is needed to size short circuit protection: The Phase of the motor, Locked Rotor Amps (LRA), and Rated Load Amps (RLA). (RLA is not provided on welded compressor nameplates.) This data is also available in Section F.

C1

The Electrical Handbook Fuse Selection Charts adjust this nameplate data so that all that is necessary for standard compressor short circuit time delay fuse protection sizing is to answer the Selection Chart questions, determine a **multiplier** for **RLA**, and size the compressor fuse accordingly.

### **FUSE SELECTION PROCEDURE CHART FOR WELDED COMPRESSORS AND COPELAND SCROLL COMPRESSORS**

1. Determine Rated Load Amps (RLA) from nameplate or Section F.
2. Determine Locked Rotor Amps (LRA) from nameplate or Section F.
3. Divide LRA/RLA for Inrush Ratio.
4. If fuse ambient temperature is greater than 120°F, multiply Inrush Ratio by 1.08.
5. For Single Phase compressors, multiply RLA by:  
1.6 if Inrush Ratio is 5 or less, or  
1.7 if Inrush Ratio is more than 5.
6. For Three Phase compressors, multiply RLA by:  
1.5 if Inrush Ratio is 4 or less, or  
1.6 if Inrush Ratio is more than 4.
7. Use the next higher Time Delay fuse rating above the adjusted RLA value calculated in step 5 or step 6.

**NOTE: IN NO CASE MAY FUSE RATING EXCEED  
225% OF COMPRESSOR RLA!**

C2



**FUSE SELECTION PROCEDURE CHART FOR  
COPELAMETIC COMPRESSORS**

1. Determine Rated Load Amps (RLA) from nameplate or Section F.
2. Determine Locked Rotor Amps(LRA) from nameplate or Section F.
3. Divide LRA/RLA for Inrush Ratio.
4. If fuse ambient temperature is greater than 120°F, multiply Inrush Ratio by 1.08.
5. For Single Phase compressors, multiply RLA by:  
1.5 if Inrush Ratio is 5 or less, or  
1.6 if Inrush Ratio is more than 5.
6. For Three Phase compressors, multiply RLA by:  
1.4 if Inrush Ratio is 4 or less, or  
1.5 if Inrush Ratio is more than 4.
7. Use the next higher Time Delay fuse rating above the adjusted RLA value calculated in step 5 or step 6.

**NOTE: IN NO CASE MAY FUSE RATING EXCEED  
225% OF COMPRESSOR RLA!**

C3

## SECTION D

### COMPRESSOR NOMENCLATURE

#### TOPICS

Welded Compressors .....	D2
HFC Welded Compressors.....	D4
A-Line .....	D6
CRKQ, CIKQ .....	D8
CR7, CR6, CRKF, CS, CF .....	D10
Copelametic® .....	D12
Copeland Discus™ .....	D14
Refrigeration Copeland Scroll® .....	D16
A/C Copeland Scroll® .....	D18
Condensing Unit (All models except M-Line) .....	D20
M-Line Condensing Unit .....	D22
Copeland Screw™ .....	D24

This section contains current information on Copeland® brand products. Information on obsolete models can be obtained from your local Emerson Climate Technologies, Inc. wholesaler.

For individual model designations, visit On-Line Product Information at [www.emersonclimatecustomer.com](http://www.emersonclimatecustomer.com).

# NOMENCLATURE • WELDED COMPRESSORS

Code	Description
E	= High Efficiency
F	= Low Temperature
R	= High Temperature
T	= Two Speed
S	= Medium Temperature

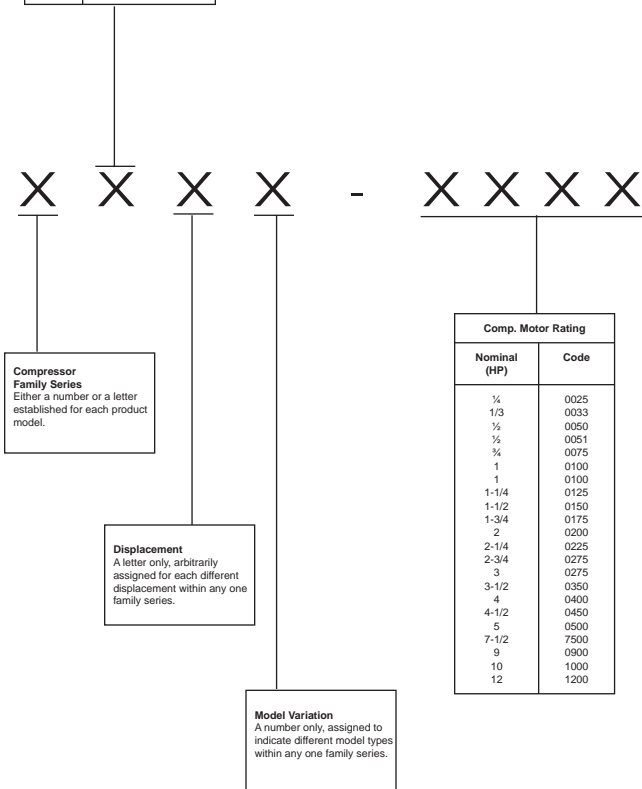

# NOMENCLATURE • WELDED COMPRESSORS

Compressor Motor Types		
Phase	Description	Code
1	Capacitor Run - Capacitor Start	C
1	Induction Run - Capacitor Start	I
1	Capacitor Run - Permanent Split Capacitor	P
3	Three Phase	T

Compressor Motor Protection	
Type Protection	Code
External Inherent Protection - One Protector (Line Break) Use with Contactor	A
Internal Thermal Protection - Electronic Sensors; and Control Module External Use with Contactor	S
Internal Inherent Protection - One Protector (Line Break)	F



Electrical Codes		
60 HZ	50HZ	Code
115-1	-	A
230-1	200/240-1	B
208/230-3	200/220-3	C
460-3	380/420-3	D
575-3	500-3	E
265-1	220/240-1	J
	380/420-3	M
208/230-1	200-1	V
	220/240-1	Z
200/230-3	200/240-3	5

(Refer to model data or nameplate for specific nominal voltage.)

Product Variations
Numbers will be assigned as follows:
1. Number - 100 is standard compressor used in Copeland brand Condensing units.
2. Number - 200 indicates a STANDARD Compressor and Component Parts B/M and Model No.
3. Number - 700 and -900 series indicate OEM and Wholesaler service B/M and model number.
4. Number - 201 and larger will be assigned for all other variations of a given model.

# NOMENCLATURE • HFC WELDED COMPRESSORS

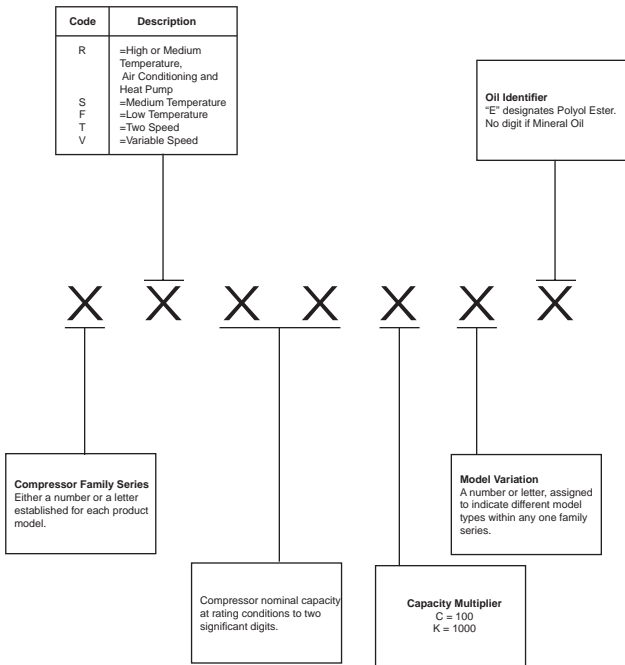

# NOMENCLATURE • HFC WELDED COMPRESSORS

Compressor Motor Types		
Phase	Description	Code
1	Capacitor Run – Capacitor Start	C
1	Induction Run – Capacitor Start	I
1	Capacitor Run – Permanent	P
3	Capacitor Run – Split Capacitor	T

Bill of Material  
Product Variations

- X X X - X X X

Typical Electrical Codes		
60 HZ	50HZ	Codes
115-1	-	A
230-1	200/240-1	B
208/230-3	200/230	C
460-3	380/420-3	D
575-3	550-3	E
265-1	220/240-1	J
-	220/240-3	R
-	380/420-3	M
208/230-1	200-1	V
-	220/240-1	Z
200/230-3	200/240-3	S

(Refer to model data or nameplate for specific nominal voltage.)

Compressor Motor Protection	
Type	Code
External Inherent Protection- One Protector (Line Break) Use with Contactor	A
Internal Inherent Protection- One Protector (Line Break) Use with Contactor	F

# NOMENCLATURE • A-LINE COMPRESSORS

Application Range		
Code	Description	Rating Point
S	Medium & Extended Temperature R-404A, R-22	20/120
F	Extended Medium R-134a, R-404A	-10/120
R	High Temperature R-134a	45/130

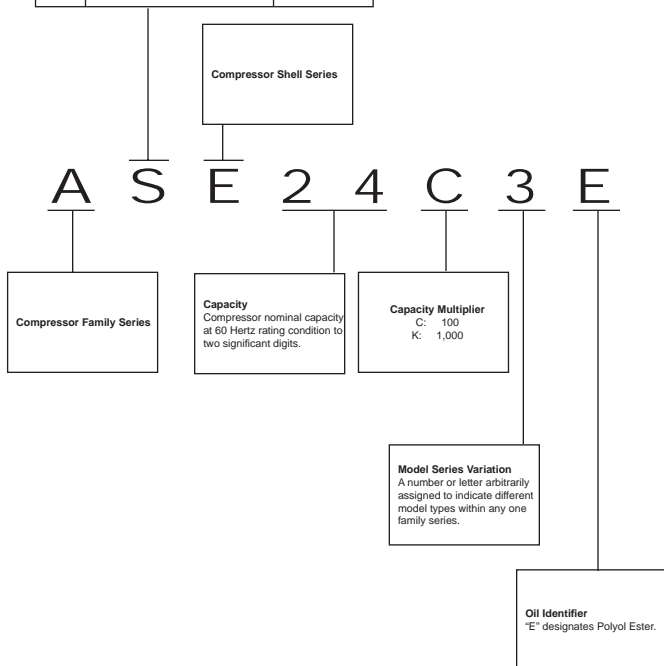

# NOMENCLATURE • A-LINE COMPRESSORS

Compressor Motor Protection	
Type Protection	Code
Internal Thermal Protection – Electronic Sensors; and Control Module External	S
Internal Inherent Protection – One Protector (Line Break) Use with Contactor	F
External Inherent Protection – One Protector (Line Break) Use with Contactor	A

Compressor Motor Types		
Phase	Description	Code
1	Capacitor Run – Capacitor Start	C
1	Induction Run – Capacitor Start	I
1	Capacitor Run – Permanent Split Capacitor	P
3	Three Phase	T
1	Induction Run – Split Phase	S

**Product Variations**  
Three-digit Bill of Material number that indicates compressor configuration and may include accessories.

- I A A - 2 0 1

Voltage Ranges (Typical)							
Voltage		60 Hertz Rating			50 Hertz Rating		
Family	Code	Rating	Min.	Max.	Rating	Min.	Max.
C, R	A	115-1	103	127	-	-	-
A	A	115-1	103	127	100	90	110
All	C	208/230-3	207	253	200/220-3	180	240
All	D	460-3	414	506	380/420-3	342	462
All	E	575-3	518	633	500-3	450	550
All	J	265-1	239	292	220/240-1	198	264
C, R	V	208/230-1	197	253	200-1	180	200
A	V	208/230-1	187	244	200-1	180	220
C, R	Z	-	-	-	220/240-1	198	264
A	Z	-	-	-	220-240-1	198	254
All	S	200/230-3	187	253	200-240-3	180	264
C	T	-	-	-	200/240-1	180	252

BTU Model Families					
	A	R	CRK6	CRKQ	CS
22	X	X	X	X	X
134a	X	X			X
404A		X			X
507					X



# NOMENCLATURE • CRKQ, CIKQ MODELS

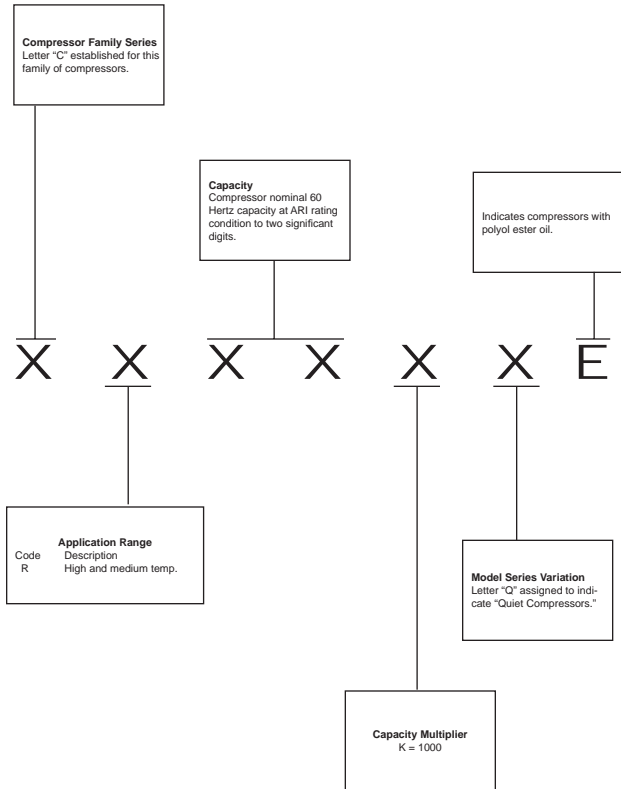

# NOMENCLATURE • CRKQ, CIKQ MODELS

Compressor Motor Types		
Phase	Description	Code
1	Capacitor Run – Permanent Split Capacitor	P
3	Three Phase General- 3 Lead Single Voltage 6 Lead Part Winding	T

**Product Variations**  
Three-digit Bill of Material number that indicates compressor configuration and accessories included.

- X X X - X X X X X

Typical Electrical Codes		
50 HZ	60 HZ	Code
200-1	208/230-1	V
200/240-1	-	T
220/240-1	-	Z
380/420-3	460-3	D
200/240-3	200/230-3	5

**External Variations**  
Optional alpha letters that indicate external accessories.

Compressor Motor Protection	
Type Protection	Code
Internal inherent protection – One protector, Use with contactor (single or three phase)	F

# NOMENCLATURE • CR7, CR6, CRKF, CS, CF MODELS

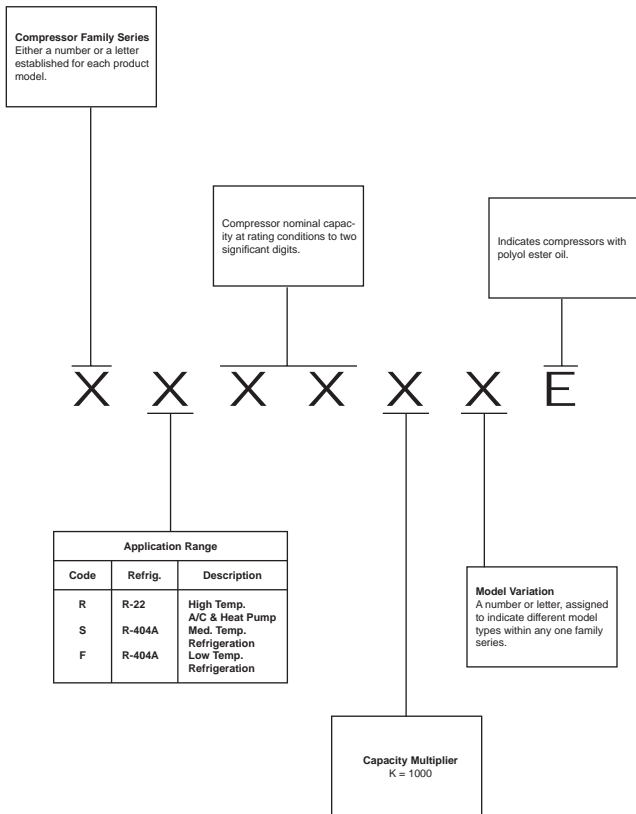

# NOMENCLATURE • CR7, CR6, CRKF, CS, CF MODELS

Compressor Motor Types		
Phase	Description	Code
1	Capacitor Run – Permanent Split Capacitor	P
3	Three Phase General – 3 Lead Single Voltage 6 Lead Part Winding (575 Volt)	T

Product Variations
Numbers will be assigned as follows:
1. Number –230 indicates a standard compressor B/M and model number.
2. Number –270 indicates a standard compressor B/M with crankcase heater.
3. Number –500 series indicates international standard compressor B/M and model number.
4. Number –730 indicates a standard OEM service B/M and model number.
5. Number –700 and –900 series indicate standard OEM and Wholesaler service B/M and model number.
6. For B/M different from –230, -270, and –730, contact Emerson Climate Technologies, Inc. Sales and Service.

- X X X - X X X

Electrical Codes		
60 Hz.	50 Hz.	Code
208/230-3	200/220-3	C
460-3	380/420-3	D
575-3	500-3	E
265-1	220/240-1	J
-	380/420-3	M
208/230-1	200-1	V
-	220/240-1	Z
-	360/460-3	1*
-	180/260-1	2*
200/230-3	200/240-3	5

\* Wide voltage range for India produced products

Compressor Motor Protection	
Type Protection	Code
Internal Inherent Protection – One Protector (Single or three phase)	F

# NOMENCLATURE • COPELAMETIC MODELS

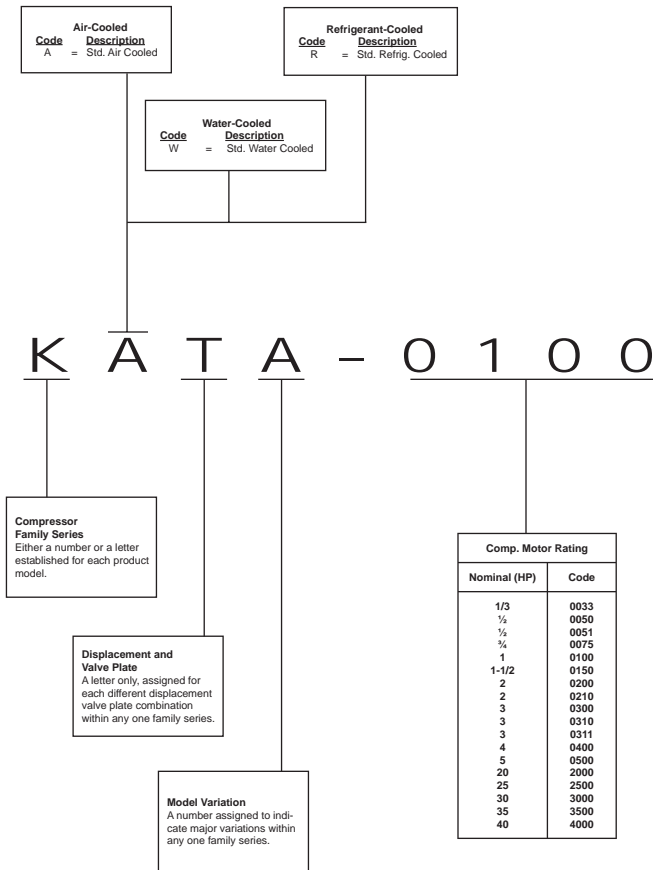

# NOMENCLATURE • COPELAMETIC MODELS

Compressor Motor Types		
Phase	Description	Code
1	Capacitor Run – Capacitor Start	C
1	Induction Run – Capacitor Start	I
3	Three Phase	T
3	Wye (star) Delta	E
3	6 Lead Part Winding or Across The Line – except 575V	F

### Product Variations

Numbers will be assigned as follows:

- Number –100 is standard compressor used in Copeland brand Condensing Units.
- Number –200 indicates a STANDARD Compressor Parts B/M and Model No.
- Number –201 and larger will be assigned for all other variations of a given model.
- Number –800 indicates a standard replacement Compressor and Component Parts B/M and Model No. –240 volt control.
- Number –801 indicates a standard replacement Compressor and Component Parts B/M and Model No. –120 volt control.

- C A V - 2 0 1

Compressor Motor Protection	
Type Protection	Code
External Inherent Protection-One Protector, (Line Break) Use with Contactor	A
Internal Inherent Protection-One Protector (Line Break) Use with Contactor	F
Internal Thermal Protectors-Electronic Sensors; and Control Module External Use with Contactor	S

Electrical Codes		
60 Hz.	50 Hz.	Code
115-1	-	A
230-1	-	B
208/230-3	200/220-3	C
460-3	380/420-3	D
575-3	550-3	E
208/230/460-3	200/380/400-3	K
-	210/240/380/420-3	L
-	380/420-3	M
230/460-3	200/400-3	N
200-3	-	U
208/230-1	200/220-1	V
-	220/240-1	Z
200/220/380-3	200/380-3	8

# NOMENCLATURE • COPELAND DISCUS MODELS

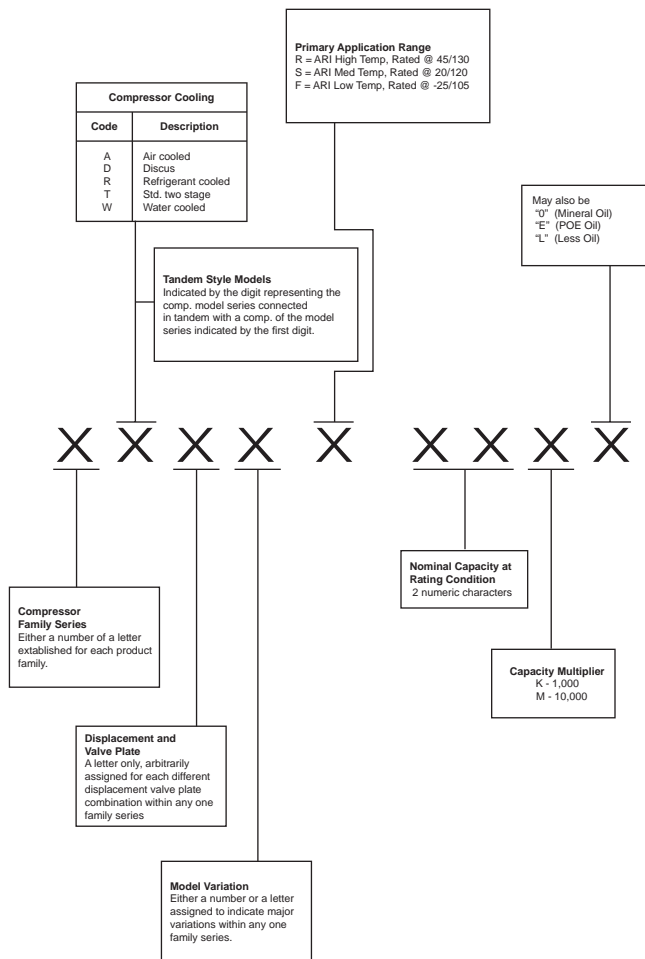

# NOMENCLATURE • COPELAND DISCUS MODELS

Compressor Motor Types	
Single Phase Motors	Code
Capacitor run - capacitor start	C
Induction run - capacitor start	I
Induction run - split phase	S
Induction run - capacitor start, low torque	X
Three Phase Motors	Code
General	T
3 Lead single voltage	
6 Lead part winding (575 volt)	
9 Lead dual voltage	
Star (wye) delta	E
6 Lead motors	
Part winding or across the line	F

## Product Variations

Numbers will be assigned as follows:

- Numbers -001 through -199 are reserved for sub-b/m numbers.
- Numbers -200 indicates a standard compressor and component parts b/m and model no.
- Numbers -201 and larger will be assigned for all other variations of a given model.

- X X X X X X X

Compressor Motor Protection	
Type Protection	Code
External inherent protection-one protector (line break) use with contactor	A
Internal inherent protection-one protector use with contactor	F
Internal thermostat(s); and ext. supplementary protector(s) use with contactor	H
Internal thermostat(s); and three ext. supplementary protectors use with contactor	L
Internal thermal protectors-electronic sensors; and control module external. Use with contactor.	S
Internal thermal protectors-electronic sensors; and control module external. Use with contactor (For European use only)	W

Electrical Codes		
60 Hz.	* 50 Hz. (Typical)	Code
115-1	100-1	A
230-1	200-1	B
208-230-3	200/220-3	C
460-3	380/400-3	D
575-3	500-3	E
--	115-1	F
--	230-1	G
208-1	200-1	H
--	208/230-1	I
--	200/400-3	K
208/230/460-3	210/240/380-3	L
--	380/420-3	M
230/460-3	200/400-3	N
--	200/380-3	P
--	200/240-3	R
--	220-1	S
--	200-1	T
200-3	--	U
208-230-1	200-1	V
--	200/220-3	W
Misc. A.C. Ratings	X	
--	500-3	Y
--	220/240-1	Z
200-1	200-1	3
100-1	100-1	4
200-230-3	--	5
230-3	--	6
380	346	7
200/220/380	200/346	8



# NOMENCLATURE • REFRIGERATION SCROLL MODELS

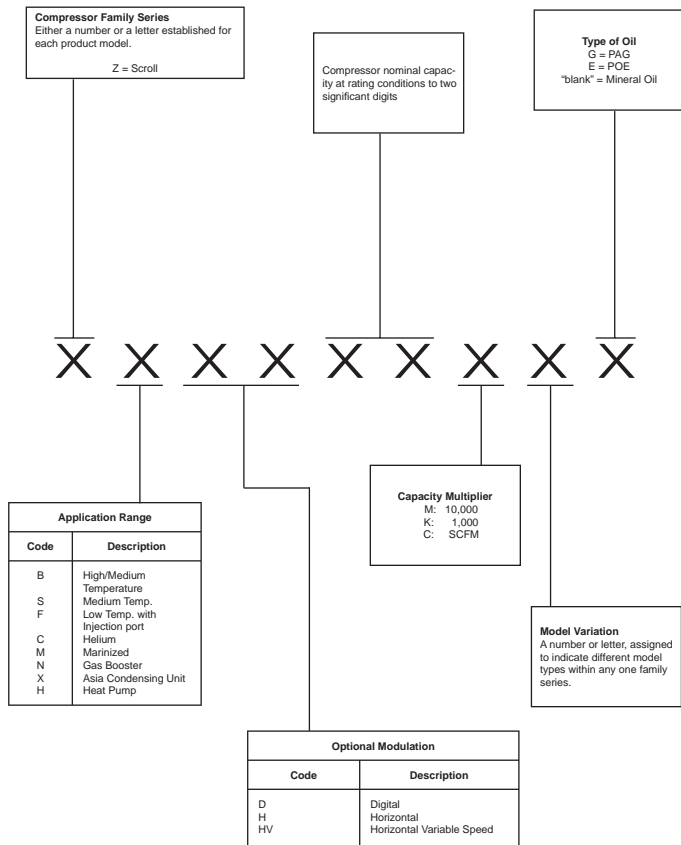

# NOMENCLATURE • REFRIGERATION SCROLL MODELS

Compressor Motor Types		
Phase	Description	Code
1	Capacitor Run – Permanent Split Capacitor	P
3	General 3 Lead Single Voltage 6 Lead Part Winding (575 Volt)	T

**Product Variations**  
 Numbers will be assigned as follows:

- 230/231 - Standard Compressor & Component Parts w/ Flag Terminal
- 250/251 - Standard Compressor & Component Parts w/ Screw Terminal
- 240/241 - Rotolock Compressor & Component Parts w/ Flag Terminal
- 261/265 - Rotolock Compressor & Component Parts w/ Screw Terminal
- 900 series indicates standard OEM and wholesaler service.
- Other numbers designate variations.



Voltage Ranges (Typical)						
Voltage	60 Hertz Rating			50 Hertz Rating		
	Code	Rating	Min.	Max.	Rating	Min.
C	208/230-3	187	253	200-3	180	220
D	460-3	414	506	380/420-3	342	462
E	575-3	518	633	500-3	450	550
V	208/230-1	197	253	200-1	180	220
5	200/230-3	180	253	200/220-3	180	242
7	380-3	342	418	-	-	-
J	265-1	239	292	220/240-1	198	264
R	-	-	-	220/240-3	180	264

Compressor Motor Protection	
Type Protection	Code
Internal Inherent Protection- One Protector Use with Contactor (Single or Three Phase)	F
External Electronic Protection (Three Phase)	W

# NOMENCLATURE • A/C SCROLL MODELS

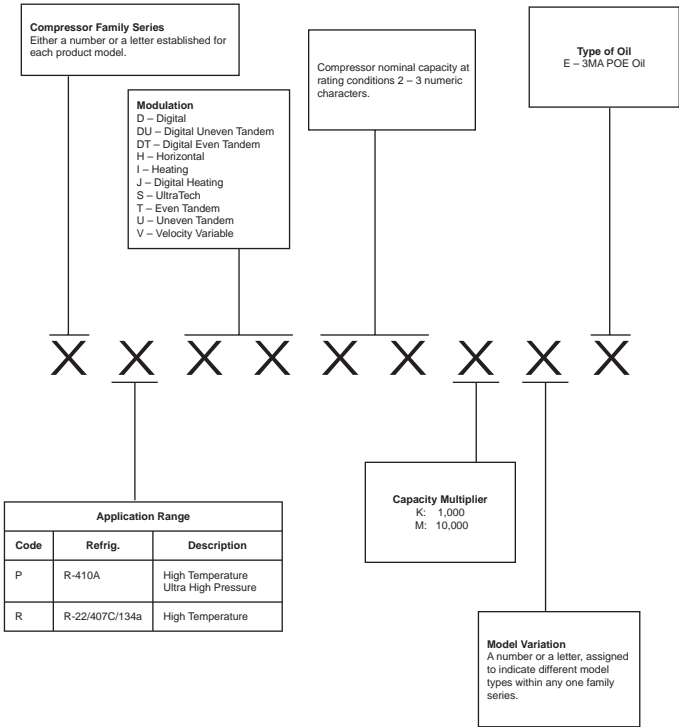

# NOMENCLATURE • A/C SCROLL MODELS

Compressor Motor Types		
Phase	Description	Code
1	Capacitor Run – Permanent Split Capacitor	P
3	General 3 Lead Single Voltage 6 Lead Part Winding (575 Volt)	T

Product Variations
1. 130/135/160 - Molded Plug
2. 230/235/260 - Quick Terminals T-box
3. 250/265 - Screw Terminals T-box
4. 7xx/9xx - T-box Service
5. 8xx - Molded Plug Service

- X X X - X X X

Compressor Motor Protection	
Type Protection	Code
Internal Inherent Protection- One Protector Use with Contactor (Single or Three Phase)	F
External Electronic Protection- Kriwan Module (Three Phase)	W

Electrical Codes		
60 Hz.	50 Hz.	Code
208/230-3	200-3	C
460-3	380/420-3	D
575-3	-	E
265-1	220/240-1	J
-	380-420-3	M
-	220/240-3	R
208/230-1	-	V
Misc.	Misc.	X
200/230-3	200/220-3	5
380-3	-	7
	220/240-1	Z

# NOMENCLATURE • CONDENSING UNIT

Design Series and Refrigerant		
Letters (Except K,L,M) K, L M Numbers (Except 6 & 7) 6, 7 X, 9	R-12 R-22 LT R-22 LT Discus R-22/R-502 R-12/R-502 Special Design	
(Different series type may indicate a major design revision.)		
New HFC Refrigerant Indicator		
Pressure Rating Approved Refrigerants	Standard Models	Special Designs
Medium High and Medium High	T P J	R N E

All Models Except M-Line

X X X X - X X X X

Condensing Unit  
Family Series

Type of Design	
Type	Code
Air Cooled	A
No condenser	N
Water cooled	W
Evaporating Pan Base	E
Discus	D

Application Temperature*	
Temperature Range	Code
High Temperature 45°F Max.; 0°F Min.	H
Medium Temperature 25°F Max.; -5°F Min.	M
Medium Temperature 25°F Max.; -25°F Min.	F
Low Temperature 0°F Max.; -40°F Min.	L
Extra Low Temperature -20°F Max.; -40°F Min.	E
Two Stage 0°F Max.; -40°F Min.	T
Two Stage (Extra Low) -30°F Max.; -80°F Min.	U
Commercial Application High & Med. Temperature Single Refrigerant	C
Dual Application R-22 HT, R-502 MT	D
Multiple Application R-12 H/MT, R-502 LT	B

NOTE: Limited or extended range will be shown in performance data tables.

Typical Motor Rating	
Nominal (HP)	Code
1/4	0025
1/3	0033
1/2	0050
3/4	0075
1	0100
1-1/2	0150
2	0200
2-1/2	0250
3	0300
3-1/2	0350
4	0400
5	0500
6	0600
7-1/2	0750
9	0900
10	1000
15	1500
20	2000
22	2200
25	2500
27	2700
30	3000
40	4000
50	5000
60	6000
70	7000
80	8000

\*NOTE: Left hand position may contain a letter indicating a revision (on units less than 10 HP).  
Right hand position may contain the letter "Z" indicating a Glacier™ scroll compressor.

# NOMENCLATURE • CONDENSING UNIT

Compressor Motor Type	
Single Phase Motors	Code
Capacitor Run-Capacitor Start Induction Run-Capacitor Start Induction Run-Split Phase Induction Run-Capacitor Start, Low Torque Capacitor Run-Permanent Split Capacitor	C I S X P
Three Phase Motors	Code
General 3 Lead Single Voltage 6 Lead Part Winding 575 V 9 Lead Dual Voltage Star (Wye) Delta 6 Lead Motors Part Winding or Across the Line	T     E F

Bill of Material Product Variations	
Variation (B/M) Number	UL/CSA Eligibility
001 thru 099	Intended for UL Listing and CSA Certified.
100 thru 299	Intended for UL Recognition and CSA Certified.
300 thru 399	Not Eligible for either UL Listing, LU Recognition, or CSA Certified.

- X X X - X X X

Compressor Motor Protection	
Type Protection	Code
External Inherent Protection – One Protector, (Line Break) Use with Contactor (single or three phase)	A
Internal Inherent Protection – One Protector, Use with Contactor. (single or three phase)	F
Internal Thermostat(s); and External Supplementary Protector(s). (Two for 3Ø, one for 1Ø.) Use with Contactor.	H
Internal Thermostat(s); and Three External Supplementary Protectors. Use with Contactor.	L
Internal Thermal Protectors – Electronic Sensors; and Control Module External. Use with Contactor.	S
Internal Thermal Protectors – Electronic sensors; and control module external. Use with contactor. (For European use only).	W

Typical Electrical Codes		
60 Hz.	50 Hz.	Code
115-1	100-1	A
230-1	200-1	B
208/230-3	200/220-3	C
460-3	380/400-3	D
575-3	500-3	E
-	115-1	F
-	230-1	G
-	200-1	H
208-1	208/230-1	I
-	220/240-1	J
265-1	200/400-3	K
208/230/460-3	210/240/380-3	L
-	380/420-3	M
-	200/400-3	N
230/460-3	-	O
All D.C. Ratings	200/380-3	P
-	200/240-3	R
-	220-1	S
-	200-1	T
200-3	-	U
208/230-1	200-1	V
-	200/220-3	W
Misc. A.C. Ratings	-	X
-	200/220-3	Y
-	220/240-1	Z
200-1	200-1	3
100-1	100-1	4
200/230-3	-	5
230-3	-	6

\*NOTE: When applicable, specific 50 Hz ratings (not necessarily identical to typical shown above) will be shown as alternate on 60 Hz rated models.

# NOMENCLATURE • M-LINE CONDENSING UNIT

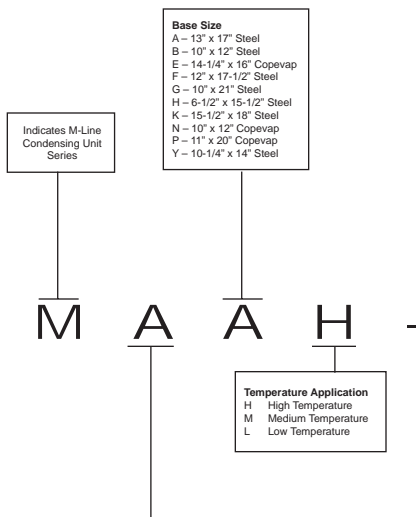

CFC & HCFC Construction & Refrigerant Indicator (All Model Codes Signify UL Recognized Units)					
R-12	R-22 R-502	Receiver	Construction Style		Power Cord
			Fan Guard	BX	
A	E	X			X
G	M	X		X	X
I	Y			X	
J	D		X		
K	P	X	X		X
L	Q		X		X
U	S	X	X	X	
V	T		X	X	
New HFC Refrigerant Indicator No reference to Construction and UL or CSA					
Pressure Rating of Approved Refrigerants				M-Line	
Medium				2	
High and Medium				3	
High				4	

# NOMENCLATURE • M-LINE CONDENSING UNIT

Hot Gas Evaporator Tube	
O E M	No Tube Epoxy Coated Copper Tube Monel Tube

Common Bill of Material Variations	
CFC & HCFC Models	
010 100's 200's	Wholesale (Single Pack) OEM (Single Pack) OEM (Multi Pack)
HFC Models	
New HFC products have the same B.O.M. structure as F-Line.	

- 0 033 - IAA - XXX

Nominal HP	
M-Line	HP
013	1/8
017	1/6
020 to 023	1/5
024 to 027	1/4
032 to 037	1/3
049 to 051	1/2
075	3/4
100	1

Voltage (Start Torque)		
IAA	115-1-60	(High)
SAA	115-1-60	(Low)
PAA	115-1-60	(Low)
IAV	208/230-1-60	(High)
CAV	208/230-1-60	(High)
IAS	220-1-50	(High)
IAZ	220/240-1-50	(High)
SAZ	220/240-1-50	(Low)



# NOMENCLATURE • COPELAND SCREW COMPRESSOR

Body Type	
Code	Description
C	Compact
H	Semi-hermetic
D	Open Drive

<b>Lubricant</b>
O = R22
E = HFC

S C H 2 - 9 0 0 0

Copeland Screw  
Compressor

Temperature Application
H = High
M = Medium
L = Low
A = Optimized for R-134a (COMPACT ONLY)

Model Variation
A number assigned to indicate major variations within any one family series. A number assigned to individual major variations within any one family series, for screw compressors 1 or 2.

Comp. Motor Rating	
Nominal (HP)	Code
20	200
25	250
30	300
35	350
40	400
50	500
60	600
70	700
75	750
80	800
80	801*
90	900
90	901*
110	11H
125	12H
140	14H
160	16H
180	18H
210	21H
240	24H
280	28H
300	30H

\*801 and 901 Frame 2 SCA2 Only

# NOMENCLATURE • COPELAND SCREW COMPRESSOR

Compressor Motor Types		
Phase	Description	Code
3	6 Lead Part Winding or Across The Line – except 575 V	F
3	Misc. 3 Phase • Single voltage 3 lead • Dual voltage 9 lead • 575 V 60 H/500 V 50 HZ 20 H.P. & up 6 lead Part Winding	T
3	Star (WYE) Delta	E

**Product Variations**  
Numbers will be assigned as follows:

1. Number –200 indicates a STANDARD Compressor and Component Parts B/M and Model No.
2. Number – 800 indicates a standard replacement compressors and component parts and model no.

- F W D - 2 0 0

Compressor Motor Protection	
Type Protection	Code
Internal Thermal Protectors- Electronic Sensors; and Control Module External Use with Contactor	W

Electrical Codes		
60 Hz.	50 Hz.	Code
208/230-3	200/220-3	C
460-3	380/420-3	D
575-3	550-3	E
208/230/460-3	200/380/400-3	K

**SECTION E**  
**ELECTRICAL COMPONENT NOMENCLATURE**  
**AND DATA**

**TOPICS**

Potential Relay Nomenclature.....	E1
G.E. Numbering System .....	E1
Potential Relay Data .....	E2
Current Relay Data .....	E7
Start Capacitor Data.....	E16
Run Capacitor Data.....	E22

This section contains current information on Copeland® products. Information on obsolete models can be obtained from your local wholesaler carrying Copeland brand products.

### Potential Relay Nomenclature

General Electric has somewhat of a complicated numbering system for potential relays. Without a complete catalog, the numbering designations are not self-explanatory, but a basic understanding of the nomenclature is helpful in identifying potential replacements in an emergency situation.

### G.E. Numbering System

A typical General Electric potential relay number is as follows: 3ARRA3CT6D5

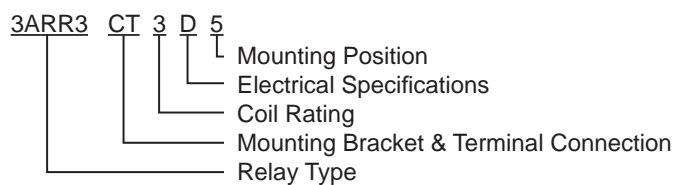

### Potential Relay Data

Wholesaler P/N	Copeland® Brand P/N	GE P/N	Pick-up Volts	Drop Out Volts	Cont. Volt Rating	Freq.
940-0001-48	040-0001-48	3ARR3KC7M5	150 - 160	15 - 45	130	60
940-0001-53	040-0001-53	3ARR3KC10A5	260 - 280	50 - 110	375	60
940-0001-54	040-0001-54	3ARR3KC10V5	240 - 260	60 - 121	375	60
940-0001-55	040-0001-55	3ARR3KC10S5	190 - 200	40 - 105	375	60
940-0001-56	040-0001-56	3ARR3KC3T5	200 - 220	40 - 90	332	60
940-0001-59	040-0001-59	3ARR3KC6W5	210 - 230	60 - 125	420	60
940-0001-60	040-0001-60	3ARR3KC24S5	190 - 200	55 - 115	383	60
940-0001-62	040-0001-62	3ARR3KC5M5	150 - 160	35 - 77	253	60
940-0001-63	040-0001-63	3ARR3KC10C5	300 - 320	50 - 110	375	60
940-0001-64	040-0001-64	3ARR3KC6A5	260 - 280	60 - 121	420	60
940-0001-69	040-0001-69	3ARR3KC4D5	320 - 340	60 - 135	500	60
940-0001-71	040-0001-71	3ARR3KC10B5	280 - 300	50 - 110	375	60
940-0001-78	040-0001-78	3ARR3KC10AS5	190 - 200	40 - 105	338	50
940-0001-79	040-0001-79	3ARR3KC3P5	170 - 180	40 - 90	332	60
940-0001-80	040-0001-80	3ARR3KC2L5	140 - 150	20 - 45	168	60
940-0001-82	040-0001-82	3ARR3KC3U5	220 - 240	40 - 90	332	60
940-0001-83	040-0001-83	3ARR3K6A5	260 - 280	60 - 121	420	60
940-0001-84	040-0001-84	3ARR3K6B5	280 - 300	60 - 121	420	60
	040-0001-85	3ARR3K4B5	280 - 300	60 - 135	500	60
	040-0001-86	3ARR3K4A5	260 - 280	60 - 135	500	60
940-0001-64	040-0001-87	3ARR3J6A5	260 - 280	60 - 121	420	60
940-0001-88	040-0001-88		220 - 240	60 - 121	420	60

E2

### Potential Relay Data

Wholesaler P/N	Copeland® Brand P/N	GE P/N	Pick-up Volts	Drop Out Volts	Cont. Volt Rating	Freq.
940-0007-00	040-0007-00	3ARR3C7M2	150 - 160	15 - 45	130	60
940-0007-02	040-0007-02	3ARR3C5AA2	260 - 280	35 - 77	228	50
940-0007-04	040-0007-04	3ARR3C24E2	340 - 360	55 - 125	336	60
940-0046-18	040-0046-18	3ARR22J24E5	340 - 360	55 - 125	383	60
940-0046-19	040-0046-19	3ARR22J6D5	320 - 340	60 - 121	420	60
	040-0046-20	3ARR22J5P5	170 - 180	35 - 77	253	60
940-0046-21	040-0046-21	3ARR22J7M5	150 - 160	15 - 45	130	60
940-0046-22	040-0046-22	3ARR22J25AC5	300 - 320	60 - 133	400	50
940-0046-23	040-0046-23	3ARR22J10B5	280 - 300	50 - 110	375	60
	040-0046-24	3ARR22J4AD5	320 - 340	60 - 135	0	
940-0140-00	040-0140-00	3ARR3KC6AC5	300 - 320	60 - 121	378	50
940-0140-07	040-0140-07		260 - 280	40 - 90	299	50
940-0140-00	040-0166-00	3ARR3T6AC5	300 - 320	60 - 121	343	50
940-0140-02	040-0166-01	3ARR3T4AA5	260 - 280	60 - 135	395	50
940-0140-03	040-0166-02	3ARR3T25S5	190 - 200	60 - 130	395	60
940-0140-04	040-0166-03	3ARR3T3S5	190 - 200	40 - 90	290	60
940-0140-05	040-0166-04	3ARR3T6AA5	260 - 280	60 - 121	343	50
940-0140-06	040-0166-05	3ARR3T10AT5	200 - 220	40 - 105	296	50
940-0140-07	040-0166-06	3ARR3T3AA5	260 - 280	40 - 90	261	50
940-0140-08	040-0166-07	3ARR3KC3L5	140 - 150	40 - 90	290	60
940-0001-48	040-0166-08	3ARR3T7M5	150 - 160	15 - 45	114	60
940-0001-49	040-0166-09	3ARR3T3E5	340 - 360	50 - 100	290	60

E3

### Potential Relay Data

Wholesaler P/N	Copeland® Brand P/N	GE P/N	Pick-up Volts	Drop Out Volts	Cont. Volt Rating	Freq.
940-0001-50	040-0166-10	3ARR3T24E5	340 - 360	55 - 125	336	60
940-0001-51	040-0166-11	3ARR3T5P5	170 - 180	35 - 77	221	60
940-0001-52	040-0166-12	3ARR3T25AC5	300 - 320	60 - 133	406	50
940-0001-53	040-0166-13	3ARR3T10A5	260 - 280	50 - 110	375	60
940-0001-54	040-0166-14	3ARR3T10V5	240 - 260	60 - 121	375	60
940-0001-55	040-0166-15	3ARR3T10S5	190 - 200	40 - 105	375	60
940-0001-57	040-0166-17	3ARR3T23AA5	260 - 280	45 - 109	262	50
940-0001-59	040-0166-18	3ARR3T6W5	210 - 230	60 - 125	420	60
940-0001-60	040-0166-19	3ARR3T24S5	190 - 200	55 - 115	383	60
940-0001-61	040-0166-20	3ARR3T6D5	320 - 340	60 - 121	420	60
940-0001-62	040-0166-21	3ARR3T5M5	150 - 160	35 - 77	253	60
940-0001-63	040-0166-22	3ARR3T10C5	300 - 320	50 - 110	375	60
940-0001-64	040-0166-23	3ARR3T6A5	260 - 280	60 - 121	420	60
940-0001-65	040-0166-24	3ARR3T10AA5	260 - 280	50 - 110	338	50
940-0001-66	040-0166-25	3ARR3T3C5	300 - 320	55 - 100	332	60
	040-0166-26	3ARR3T10AB5	280 - 300	50 - 110	338	50
940-0001-68	040-0166-27	3ARR3T6V5	240 - 260	60 - 121	420	60
940-0001-69	040-0166-28	3ARR3T4D5	320 - 340	60 - 135	500	60
940-0001-70	040-0166-29	3ARR3T3AV5	240 - 260	40 - 90	299	50
940-0001-71	040-0166-30	3ARR3T10B5	280 - 300	50 - 110	375	60
940-0001-72	040-0166-31	3ARR3T6AB5	280 - 300	60 - 121	378	50
940-0001-73	040-0166-32	3ARR3T3AU5	220 - 240	40 - 90	299	50

E4

### Potential Relay Data

Wholesaler P/N	Copeland® Brand P/N	GE P/N	Pick-up Volts	Drop Out Volts	Cont. Volt Rating	Freq.
940-0001-75	040-0166-33	3ARR3T7J5	120 - 130	15 - 40	130	60
	040-0166-34	3ARR3T7AL5	140 - 150	15 - 40	117	50
940-0001-77	040-0166-35	3ARR3T5V5	240 - 260	35 - 77	253	60
940-0001-78	040-0166-36	3ARR3T10AS5	190 - 200	40 - 105	338	50
940-0001-79	040-0166-37	3ARR3T3P5	170 - 180	40 - 90	332	60
940-0001-80	040-0166-38	3ARR3T2L5	140 - 150	20 - 45	168	60
940-0001-82	040-0166-39	3ARR3T3U5	220 - 240	40 - 90	332	60
940-0001-83	040-0166-40	3ARR3K6A5	260 - 280	60 - 121	420	60
940-0001-84	040-0166-41	3ARR3K6B5	280 - 300	60 - 121	420	60
	040-0166-42	3ARR3K4B5	280 - 300	60 - 135	500	60
	040-0166-43	3ARR3K4A5	260 - 280	60 - 135	500	60
940-0001-64	040-0166-44	3ARR3T6A5	260 - 280	60 - 121	420	60
940-0001-88	040-0166-45	3ARR3T6U5	220 - 240	60 - 121	420	

E5



### Current Relay Data

Wholesaler P/N	Copeland® Brand P/N	GE P/N	Texas Inst. P/N	Max. Pick-up Amps	Min. Drop Out Amps
940-0088-00	040-0088-00		6409-26-196	28.9	23.7
940-0088-03	040-0088-03		6409-26-176	14.9	12.6
940-0088-04	040-0088-04		6409-26-935	33.6	27.8
940-0088-05	040-0088-05		6409-26-189	21.8	17.9
940-0088-06	040-0088-06		6409-26-900	42	36
	040-0089-04		3CR-203-171B	12.9	10.8
	040-0089-06		3CR-203-186B	22.5	18.7
940-0090-00	040-0090-00		3CR-206-174B	14.1	11.9
	040-0090-01		3CR-206-181B	17.9	15.1
940-0090-04	040-0090-04		3CR-206-191B	27.2	22.7
	040-0090-05		3CR-206-165B	10.4	8.6
940-0090-06	040-0090-06		3CR-206-189B	24.75	20.45
	040-0090-07		3CR206-154B	8.25	6.9
940-0098-01	040-0098-01		6409-40-935	33.6	27.8
940-0098-02	040-0098-02		6409-40-180	17.4	14.3
940-0102-02	040-0102-02		6409-51-176	14.9	12.6
940-0115-00	040-0115-00		3CR-111-269	12.2	10.2
	040-0115-01		3CR-111-239	6.3	5.25
	040-0115-02		3CR-111-272	13.3	11.1
	040-0128-01		3CR234-181B	17.9	15.1
940-C411-49	040-0141-00			7.7	6.5
940-C411-18	040-0141-01			3.8	3.25
940-C411-38	040-0141-02			6.2	5.25

E6

### Current Relay Data

Wholesaler P/N	Copeland® Brand P/N	GE P/N	Texas Inst. P/N	Max. Pick-up Amps	Min. Drop Out Amps
940-C411-47	040-0141-03			7.45	6.3
940-C411-58	040-0141-04			9.15	7.7
940-C411-82	040-0141-05			17.8	14.9
940-C411-52	040-0141-10			8.2	7
940-C411-66	040-0141-14			11	9.35
940-C411-72	040-0141-17			13.2	11.1
940-C411-73	040-0141-18			13.4	11.4
940-C411-79	040-0141-20			16.5	13.8
940-C411-80	040-0141-21			16.7	14
940-C411-83	040-0141-22			18.2	15.3
940-C411-82	040-0150-01		9660A-467-1822	17.8	14.9
940-C411-82	040-0150-01		9660C-3018-182	17.8	14.9
940-C411-82	040-0150-01			17.8	14.9
940-C411-66	040-0150-02			11	9.35
940-C411-49	040-0150-03			7.7	6.5
940-C411-45	040-0150-04			7.1	6
940-C411-45	040-0150-04			7.1	6
940-C411-58	040-0150-05			9.15	7.7
940-C411-83	040-0150-06		9660A-467-183	18.2	15.5
940-C411-83	040-0150-06		9660C-3018-183	18.2	15.5
940-C411-83	040-0150-06			18.2	15.5
940-C411-13	040-0150-07			3.25	2.75
940-C411-18	040-0150-08			3.8	3.25

E7

**Current Relay Data**

Wholesaler P/N	Copeland® Brand P/N	GE P/N	Texas Inst. P/N	Max. Pick-up Amps	Min. Drop Out Amps
940-C411-35	040-0150-09			5.8	4.95
940-C411-63	040-0150-10			10.3	8.6
940-C411-89	040-0150-11			21.9	18.2
940-C411-89	040-0150-11			21.9	18.2
940-C411-89	040-0150-11			21.9	18.2
940-C411-89	040-0150-11			21.9	18.2
940-C411-91	040-0150-12		9660-467-191	24.4	20.3
940-C411-91	040-0150-12		9660C-3018-191	24.4	20.3
940-C411-91	040-0150-12			24.4	20.3
940-C411-78	040-0150-13			15.8	13.3
940-C411-47	040-0150-14			7.45	6.3
940-C411-61	040-0150-15			9.75	8.2
940-C411-52	040-0150-16			8.2	7
940-C411-85	040-0150-17		9660A-467-185	19.2	16.2
940-C411-85	040-0150-17		9660C-3018-185	19.2	16.2
940-C411-85	040-0150-17			19.2	16.2
940-C411-73	040-0150-18			13.35	11.35
940-C411-72	040-0150-19			13.2	11.1
940-C411-71	040-0150-20			12.7	10.8
940-C411-40	040-0150-21			6.5	5.5
940-C411-38	040-0150-22			6.2	5.25
	040-0150-23			21.9	18.2
940-0150-24	040-0150-24			15.8	13.3

E8

### Current Relay Data

Wholesaler P/N	Copeland® Brand P/N	GE P/N	Texas Inst. P/N	Max. Pick-up Amps	Min. Drop Out Amps
940-C411-55	040-0150-25			8.5	7.15
	040-0150-31			13.7	11.5
	040-0150-31			13.7	11.5
	040-0150-32			12.1	10.3
	040-0150-33			18.2	15.5
	040-0150-34			11	9.35
	040-0150-34			11	9.35
	040-0150-35			14	11.9
	040-0150-35			14	11.9
	040-0150-36			14.7	12.5
	040-0150-36			14.7	12.5
	040-0150-37			19.9	16.6
	040-0150-37			19.9	16.6
	940-0152-00	040-0152-00			7.7
940-0152-03	040-0152-03			3.76	3.15
940-C401-82	040-0152-13			17.8	14.9
940-0102-02	040-0159-02			14.9	12.6
940-C401-25	040-0162-00			4.65	3.95
	040-0162-01			13.2	11.1
940-C401-35	040-0162-02			5.8	4.95
940-C401-82	040-0162-03			17.8	14.9
940-0152-05	040-0162-04			4.2	3.55
940-C401-58	040-0162-05			9.15	7.7

E9

### Current Relay Data

Wholesaler P/N	Copeland® Brand P/N	GE P/N	Texas Inst. P/N	Max. Pick-up Amps	Min. Drop Out Amps
940-C401-66	040-0162-07			11	9.35
940-C401-40	040-0162-08			6.5	5.5
940-0152-03	040-0162-09			3.35	2.85
940-0152-01	040-0162-10			2.29	1.96
940-0152-00	040-0162-11			7.7	6.5
940-0152-04	040-0162-12			3.76	3.15
940-0162-13	040-0162-13			9.75	8.2
940-0162-14	040-0162-14			13.2	11.1
940-0163-00	040-0163-00			9.15	7.7
940-0163-01	040-0163-01			11	9.35
940-C411-79	040-0163-02			16.5	13.8
940-C411-70	040-0163-03			12.1	10.3
940-C411-80	040-0163-04			16.7	14
940-C411-89	040-0163-05			21.9	18.2
940-C411-91	040-0163-07			24.4	20.3
940-C411-85	040-0163-08			19.2	16.2
940-C411-49	040-0167-03			7.7	6.5
940-C411-83	040-0167-06			18.2	15.5
940-C411-38	040-0167-22			6.2	5.25
940-0088-00	040-0168-00			28.9	23.7
940-0088-02	040-0168-01			17.4	14.3
940-0088-03	040-0168-02			14.9	12.6
940-0088-04	040-0168-03			33.6	27.8

E10

### Current Relay Data

Wholesaler P/N	Copeland® Brand P/N	GE P/N	Texas Inst. P/N	Max. Pick-up Amps	Min. Drop Out Amps
940-0088-05	040-0168-04			21.8	17.9
940-0088-07	040-0168-06			13.3	11.1
940-0102-00	040-0169-00			28.9	23.7
	040-0169-01			17.4	14.3
940-0102-02	040-0169-02			14.9	12.6
940-0102-03	040-0169-03			33.6	27.8
940-0102-07	040-0169-06			13.3	11.1
940-0163-00	040-0171-00			9.15	7.7
940-C411-83	040-0171-06			18.2	15.5
940-C016-00	040-0172-00			24	19.8
940-0102-04	040-0172-02			24.75	20.45
940-C016-03	040-0172-03			30.3	25.1
940-C016-03	040-0172-03			30.3	25.1
	040-0172-04			18.4	15.4
	040-0172-04			18.4	15.4
	040-0172-05			22.1	18.4
	040-0172-05			22.1	18.4
940-C016-00	040-C016-00		3CR-763-188B	24	19.8
940-0152-01	040-C401-01		9660-040-101	2.29	1.96
	040-C401-11		9660-040-111	3	2.56
940-0152-03	040-C401-14		9660-040-114	3.35	2.85
940-0152-05	040-C401-21		9660-040-121	4.2	3.55
940-C401-25	040-C401-25		9660-040-125	4.65	3.95

E11

### Current Relay Data

Wholesaler P/N	Copeland® Brand P/N	GE P/N	Texas Inst. P/N	Max. Pick-up Amps	Min. Drop Out Amps
940-C401-35	040-C401-35		9660-040-135	5.9	5
940-C401-40	040-C401-40		9660-040-140	6.5	5.5
940-0152-00	040-C401-49		9660-040-149	7.7	6.5
	040-C401-55		9660-040-155	8.5	7.15
940-C401-58	040-C401-58		9660-040-158	9.15	7.7
940-C401-66	040-C401-66		9660-040-166	11	9.2
940-C401-72	040-C401-72		9660-040-172	13.2	11.1
940-C401-82	040-C401-82		9660-040-182	17.8	14.9
940-C411-13	040-C411-13		9660B-041-113	3.25	2.77
940-C411-18	040-C411-18			3.8	3.25
940-C411-35	040-C411-35		9660B-041-135	5.9	5
940-C411-38	040-C411-38		9660-041-138	6.2	5.25
940-C411-45	040-C411-45		9660A-041-145	7	5.9
940-C411-47	040-C411-47		9660-041-147	7.4	6.2
940-C411-49	040-C411-49		9660-041-149	7.7	6.5
940-C411-52	040-C411-52			8.1	6.8
940-C411-61	040-C411-61		9660-041-161	9.75	8.2
940-C411-63	040-C411-63		9660-041-163	10.3	8.6
940-C411-66	040-C411-66		9660-041-166	11	9.2
940-C411-71	040-C411-71			12.9	10.8
940-C411-73	040-C411-73		9660A-041-173	13.7	11.5
940-C411-79	040-C411-79			16.5	13.8
940-C411-82	040-C411-82		9660A-041-182	17.8	14.9

E12

### Current Relay Data

Wholesaler P/N	Copeland® Brand P/N	GE P/N	Texas Inst. P/N	Max. Pick-up Amps	Min. Drop Out Amps
940-C411-83	040-C411-83		9660A-041-183	18.2	15.3
940-C411-83	040-C411-83		9660C-3027-183	18.2	15.3
940-C411-91	040-C411-91		9660A-041-191	24.4	20.3
940-C411-91	040-C411-91		9660C-3027-191	24.4	

E13



### Start Capacitor Data

Wholesaler P/N	Copeland® Brand P/N	MFD-Low	MFD-High	Cap Volts
914-0006-02	014-0006-02	88	106	330
914-0006-03	014-0006-03	189	227	330
914-0006-09	014-0006-09	216	259	330
914-0006-10	014-0006-10	270	324	330
914-0006-11	014-0006-11	145	174	330
914-0006-12	014-0006-12	175	216	330
914-0006-03	014-0006-13	189	227	330
914-0006-09	014-0006-14	216	259	330
914-0006-10	014-0006-15	270	324	330
914-0006-11	014-0006-16	145	174	330
014-0006-12	014-0006-17	175	216	330
	014-0008-47	460	552	115
914-0008-48	014-0008-48	124	149	220
914-0008-50	014-0008-50	161	193	220
914-0008-51	014-0008-51	145	174	220
914-0008-61	014-0008-61	88	106	220
914-0008-62	014-0008-62	53	64	220
914-0008-63	014-0008-63	540	648	115
914-0008-64	014-0008-64	43	52	220
914-0008-65	014-0008-65	64	77	330
914-0008-66	014-0008-66	108	130	220
	014-0008-68	88	106	115
914-0008-70	014-0008-70	43	52	330
914-0008-71	014-0008-71	189	227	220

E14

### Start Capacitor Data

Wholesaler P/N	Copeland® Brand P/N	MFD-Low	MFD-High	Cap Volts
914-0008-72	014-0008-72	64	77	250
914-0008-73	014-0008-73	43	52	250
914-0008-74	014-0008-74	72	86	330
914-0008-78	014-0008-78	108	130	250
914-0008-79	014-0008-79	270	324	165
914-0032-00	014-0032-00	233	280	110
914-0032-06	014-0032-06	233	280	125
	014-0032-07	41	53	250
914-0036-00	014-0036-00	53	64	330
914-0036-01	014-0036-01	88	106	250
914-0036-03	014-0036-03	88	106	330
914-0036-04	014-0036-04	145	174	250
914-0036-05	014-0036-05	108	130	330
914-0036-07	014-0036-07	130	156	330
914-0036-11	014-0036-11	72	88	220
914-0036-13	014-0036-13	21	25	330
914-0036-00	014-0036-16	53	64	330
914-0036-01	014-0036-17	88	106	250
914-0036-02	014-0036-18	130	156	250
914-0036-03	014-0036-19	88	106	330
914-0036-04	014-0036-20	145	174	250
914-0036-05	014-0036-21	108	130	330
914-0036-07	014-0036-22	130	156	330
914-0036-08	014-0036-23	340	408	110

E15

### Start Capacitor Data

Wholesaler P/N	Copeland® Brand P/N	MFD-Low	MFD-High	Cap Volts
914-0036-09	014-0036-24	243	292	165
914-0036-11	014-0036-25	72	88	220
914-0036-12	014-0036-26	189	227	250
914-0036-15	014-0036-28	189	227	165
914-0053-00	014-0038-00	145	175	165
914-0053-01	014-0038-01	145	175	110
914-0053-02	014-0038-02	53	64	250
	014-0038-03	43	52	250
914-0053-04	014-0038-04	189	227	165
914-0053-05	014-0038-05	88	106	250
914-0053-06	014-0038-06	50	60	330
914-0053-07	014-0038-07	43	53	330
914-0053-10	014-0038-10	145	174	250
914-0053-10	014-0038-17	145	174	250
914-0053-13	014-0053-13	64	77	330
914-0053-00	014-0053-18	145	175	165
914-0053-01	014-0053-19	145	175	110
914-0053-02	014-0053-20	53	64	250
914-0053-04	014-0053-21	189	227	165
914-0053-05	014-0053-22	88	106	250
914-0053-06	014-0053-23	50	60	330
914-0053-07	014-0053-24	43	52	330
914-0053-09	014-0053-25	189	227	250
914-0053-10	014-0053-26	145	174	250

E16

### Start Capacitor Data

Wholesaler P/N	Copeland® Brand P/N	MFD-Low	MFD-High	Cap Volts
914-0053-13	014-0053-29	64	77	330
914-0053-14	014-0053-30	88	108	330
	014-0053-31	53	64	330
914-0053-16	014-0053-32	130	156	330
914-0006-03	014-0058-00	189	227	330
914-0006-09	014-0058-01	216	259	330
914-0006-10	014-0058-02	270	324	330
914-0006-11	014-0058-03	145	174	330
914-0006-12	014-0058-04	175	216	330
	014-0058-05	460	552	110
914-0008-48	014-0058-06	124	149	220
914-0008-49	014-0058-07	400	480	110
914-0008-50	014-0058-08	161	193	220
914-0008-51	014-0058-09	145	174	220
914-0008-52	014-0058-10	430	516	125
914-0008-57	014-0058-11	243	292	110
914-0008-58	014-0058-12	324	389	110
914-0008-59	014-0058-13	590	708	110
914-0008-61	014-0058-14	88	106	220
	014-0058-15	53	64	220
914-0008-63	014-0058-16	540	648	110
914-0008-64	014-0058-17	43	52	220
914-0008-65	014-0058-18	64	77	330
914-0008-66	014-0058-19	108	130	220

E17

### Start Capacitor Data

Wholesaler P/N	Copeland® Brand P/N	MFD-Low	MFD-High	Cap Volts
914-0008-69	014-0058-20	270	324	110
914-0008-70	014-0058-21	43	52	330
914-0008-71	014-0058-22	189	227	220
914-0008-72	014-0058-23	64	77	250
914-0008-73	014-0058-24	43	52	250
914-0008-74	014-0058-25	72	86	330
914-0008-78	014-0058-26	108	130	250
914-0008-79	014-0058-27	270	324	165
914-0036-00	014-0058-28	53	64	330
914-0036-01	014-0058-29	88	106	250
914-0036-02	014-0058-30	130	156	250
914-0036-03	014-0058-31	88	106	330
914-0036-04	014-0058-32	145	174	250
914-0036-05	014-0058-33	108	130	330
914-0036-07	014-0058-34	130	156	330
914-0036-08	014-0058-35	340	408	110
914-0036-09	014-0058-36	243	292	165
914-0036-11	014-0058-37	72	88	220
914-0036-12	014-0058-38	189	227	250
914-0036-15	014-0058-40	189	227	165
	014-0058-41	340	408	165
	014-0058-43	243	292	250
914-0053-00	014-0059-00	145	175	165
914-0053-01	014-0059-01	145	175	110

E18

### Start Capacitor Data

Wholesaler P/N	Copeland® Brand P/N	MFD-Low	MFD-High	Cap Volts
914-0053-02	014-0059-02	53	64	250
914-0053-04	014-0059-03	189	227	165
914-0053-05	014-0059-04	88	106	250
914-0053-06	014-0059-05	50	60	330
914-0053-07	014-0059-06	43	52	330
914-0053-09	014-0059-07	189	227	250
914-0053-10	014-0059-08	145	174	250
914-0053-11	014-0059-09	72	88	330
914-0053-13	014-0059-11	64	77	330
914-0053-14	014-0059-12	88	106	330
914-0053-15	014-0059-13	53	64	330
914-0053-16	014-0059-14	130	156	330
	014-0059-18	130	156	250
	014-0059-20	243	292	165
	014-0061-00	460	552	110
914-0008-48	014-0061-01	124	149	220
914-0008-49	014-0061-02	400	480	110
914-0008-50	014-0061-03	161	193	220
914-0008-51	014-0061-04	145	174	220
914-0008-52	014-0061-05	430	516	125
914-0008-57	014-0061-06	243	292	110
914-0008-58	014-0061-07	324	389	110
914-0008-59	014-0061-08	590	708	110
914-0008-61	014-0061-09	88	106	220

E19

### Start Capacitor Data

Wholesaler P/N	Copeland® Brand P/N	MFD-Low	MFD-High	Cap Volts
	014-0061-10	53	64	220
914-0008-63	014-0061-11	540	648	110
914-0008-64	014-0061-12	43	52	220
914-0008-65	014-0061-13	64	77	330
914-0008-66	014-0061-14	108	130	220
914-0008-69	014-0061-15	270	324	110
914-0008-70	014-0061-16	43	52	330
914-0008-72	014-0061-18	64	77	250
914-0008-73	014-0061-19	43	52	250
914-0008-74	014-0061-20	72	86	330
914-0008-78	014-0061-21	108	130	250
914-0008-79	014-0061-22	270	324	165
914-0037-07	014-0064-26	60	0	370

E20

### Run Capacitor Data

Wholesaler P/N	Copeland® Brand P/N	MFD	Cap Volts	Wholesaler P/N	Copeland® Brand P/N	MFD	Cap Volts
	014-0011-01	5	330		014-0041-00	60	370
	014-0011-04	11	330		014-0041-01	80	370
914-0037-04	014-0037-04	10	370		014-0048-12	40	370
	014-0037-05	12.5	370		014-0048-18	40	440
914-0037-06	014-0037-06	15	370		014-0048-20	50	440
914-0037-07	014-0037-07	17.5	370		014-0048-21	55	440
914-0037-08	014-0037-08	20	370		014-0048-22	60	440
914-0037-09	014-0037-09	25	370		014-0048-36	45	370
914-0037-10	014-0037-10	30	370		014-0048-37	60	370
914-0037-11	014-0037-11	35	370		014-0048-38	80	370
914-0037-12	014-0037-12	40	370		014-0048-39	55	370
914-0037-13	014-0037-13	15	440		014-0048-40	50	370
914-0037-14	014-0037-14	20	440		014-0048-51	70	370
914-0037-16	014-0037-16	30	440		014-0054-12	40	370
914-0037-17	014-0037-17	35	440		014-0054-18	40	440
914-0037-18	014-0037-18	40	440		014-0054-20	50	440
914-0037-19	014-0037-19	45	440		014-0054-36	45	370
914-0037-22	014-0037-22	60	440		014-0054-37	60	370
914-0037-11	014-0037-28	35	370		014-0054-39	55	370
914-0037-36	014-0037-36	45	370		014-0054-40	50	370
914-0037-37	014-0037-37	60	370		014-0057-00	100	440
914-0037-38	014-0037-38	80	370	914-0036-03	014-0058-31	88	330
914-0037-39	014-0037-39	55	370	914-0037-04	014-0064-00	10	370
914-0037-40	014-0037-40	50	370		014-0064-01	12.5	370

E21



### Run Capacitor Data

Wholesaler P/N	Copeland® Brand P/N	MFD	Cap Volts	Wholesaler P/N	Copeland® Brand P/N	MFD	Cap Volts
914-0037-06	014-0064-02	15	370	914-0037-40	014-0064-29	50	370
914-0037-07	014-0064-03	17.5	370	914-0037-46	014-0064-30	80	370
914-0037-08	014-0064-04	20	370	914-0037-48	014-0064-31	15	440
914-0037-09	014-0064-05	25	370	914-0037-49	014-0064-32	20	440
914-0037-10	014-0064-06	30	370	914-0037-50	014-0064-33	17.5	440
914-0037-11	014-0064-07	35	370	914-0037-51	014-0064-34	70	370
914-0037-12	014-0064-08	40	370	914-0037-52	014-0064-35	80	440
914-0037-13	014-0064-09	15	440		014-0064-36	10	440
914-0037-14	014-0064-10	20	440				
914-0037-15	014-0064-11	25	440				
914-0037-16	014-0064-12	30	440				
914-0037-17	014-0064-13	35	440				
914-0037-18	014-0064-14	40	440				
914-0037-19	014-0064-15	45	440				
914-0037-20	014-0064-16	50	440				
914-0037-21	014-0064-17	55	440				
914-0037-22	014-0064-18	60	440				
914-0037-23	014-0064-19	25	482				
914-0037-29	014-0064-23	7.5	330				
914-0037-30	014-0064-24	5	330				
914-0037-36	014-0064-25	45	370				
914-0037-37	014-0064-26	60	370				
914-0037-38	014-0064-27	80	370				
914-0037-39	014-0064-28	55	370				

E22

## SECTION F

### COMPRESSOR ELECTRICAL DATA

#### TOPICS

Introduction.....	F2
A-Line .....	FA
Welded Compressors .....	FB
Copelametic Air-Cooled.....	FC
Copelametic Small Refrigerant-Cooled .....	FD
Copelametic Large Refrigerant-Cooled .....	FE
Copeland Scroll .....	FF
Copeland Screw .....	FG

This section contains current information on Copeland® products.  
Information on obsolete models can be obtained from your local Emerson Climate Technologies, Inc. wholesaler.

## **Introduction**

The electrical data is listed as an aid to the serviceman in determining compressor characteristics.

As required by U.L. requirements based on the National Electric Code, the terms nameplate amperage and full load amps have been replaced by the term "Rated Load Amps" (RLA). The value shown on the compressor nameplate is complicated by the fact that while normal operating amperage draw can be determined on a complete system by test, a compressor could really have an infinite number of operating conditions depending on its application.

In order to provide a uniform basis of 71% of maximum continuous current allowed by the motor protection system. This will allow the compressor to draw 140% of the rated load amp value prior to the protector tripping. Rated Load Amp values are not marked on new Copelametic, welded or scroll compressor nameplates unless otherwise specified by an equipment manufacturer.

Since one motor design may be used in a number of different compressor models, using different refrigerants, for different operating ranges, the Rated Load Amp value shown in the handbook may vary from the value marked on individual compressor nameplates. The handbook value is usually selected as the highest nameplate value used for a given motor, so it is always a conservative value which may be safely used in the event exact nameplate values are not known.

If refrigerant application specific RLA is required, this can be calculated from refrigerant application specific Maximum Continuous Current (MCC) listed in Emerson Climate Technologies, Inc. Online Product Information (OPI).

F2

### **Explanation of Section F Electrical Data Notes**

The following notes can be found in the headings for the data tables which are found later in this section: Copelametic compressors may have the ninth digit changed to represent variations that do not affect performance.

‡ An “E” at the ninth digit means the compressor was originally shipped with polyolester oil.

An “A” at the ninth digit means the compressor was originally shipped with alkyl benzene oil.

A “number” at the ninth digit means the compressor was originally shipped with mineral oil.

An “L” at the ninth digit means the compressor was originally shipped with no oil.

† Information on Line to Line winding resistances is found in Section A “Measuring Winding Resistance”.

‡ Capacitor values are found in Section E.

§ Potential and Current relay values are found in Section E.

\* RP = Relay Potential

\* RC = Relay Current

¥ Large refrigerant cooled compressors whose overload protectors are not listed have Emerson Climate Technologies part numbers:

071-0424-01	120V	(Texas Instruments)
071-0424-00	240V	(Texas Instruments)
071-0524-00	120V/240V	(Texas Instruments)
071-0464-01	120V	(Kriwan)
071-0464-00	240V	(Kriwan)
071-0441-01	120V	(Robertshaw)
071-0441-00	240V	(Robertshaw)
071-0520-03	24V	(Texas Instruments)
071-0520-00	120V/240V	(Texas Instruments)
071-0520-01	230V	(Kriwan)
071-0520-02	115V	(Kriwan)
071-0520-04	24V	(Kriwan)
071-0520-05	120V/240V	(Kriwan)
071-0550-00	120V/240V	(Kriwan)
071-0550-01	24V	(Texas Instruments)
071-0582-00	120/240V	(Kriwan)
071-0581-00	120/240V	(Kriwan)

F4

### Electrical Data - A-Line

Model	Volts	PH	Max RLA	LRA	Resistance		Start Cap P/N ‡	Run Cap P/N ‡	Relay P/N §	Part Type*	Protector P/N
					Start or Line/Line†	Run					
AFB04C3E-SAA	115	1	2	20	10.5	2.7			040-0162-13	RC	071-0561-13
AFB05C3E-IAA	115	1	2.8	26.5	8.5	1.9	014-0053-21		040-0150-05	RC	071-0561-08
AFB05C3E-SAA	115	1	2.7	27.5	8.5	1.9			040-0162-05	RC	071-0561-08
AFB06C3E-IAA	115	1	3.1	25	7.4	1.55	014-0053-26		040-0150-02	RC	071-0561-11
AFB09C3E-IAA	115	1	4.8	34.6	9	1.05	014-0053-26		040-0150-20	RC	071-0561-15
AFB09C3E-IAB	230	1	1.7	15	36	5.85	014-0059-13		040-0150-03	RC	071-0561-30
AFE06C4E-IAA	115	1	3.1	28.5	6.14	1.24	014-0053-18		040-0150-19	RC	071-0561-29
AFE07C3E-IAA	115	1	4.4	29	9	1.3	014-0053-26		040-0150-01	RC	071-0561-02
AFE08C4E-IAA	115	1	3.9	26.5	6.14	1.24	014-0053-18		040-0150-31	RC	071-0561-23
AFE10C3E-IAA	115	1	4.9	38	9	1.2	014-0053-26		040-0150-11	RC	071-0561-24
AFE11C3E-IAA	115	1	5.6	29	7.3	1.2	014-0053-18		040-0150-01	RC	071-0561-16
AFE11C4E-IAA	115	1	4.2	26.5	6.14	1.24	014-0053-18		040-0150-19	RC	071-0561-21
AFE12C3E-IAA	115	1	4.8	33	6.1	0.96	014-0053-21		040-0150-06	RC	071-0561-28
AFE13C3E-IAA	115	1	5.8	33	6.1	0.96	014-0053-21		040-0150-06	RC	071-0561-03
AFE13C3E-IAV	208/230	1	3.2	21.7	21.9	3.4	014-0059-13		040-0150-14	RC	071-0561-04
AFE13C4E-IAA	115	1	5.6	37.5	6.1	0.96	014-0053-21		040-0150-06	RC	071-0561-47
AFE17C4E-CAA	115	1	7.8	41.5	4.5	0.77	014-0036-28	014-0064-12	040-0166-21	RP	071-0561-48
AFE17C4E-IAA	115	1	7.8	41.5	4.5	0.77	014-0053-21		040-0150-11	RC	071-0561-48
AFJ23C1-IAA	115	1	7.2	59	4.771	0.611	014-0036-24		040-0166-38	RP	071-0605-03
AFJ23C2-IAA	115	1	9.2	54	4.771	0.611	014-0036-24		040-0166-38	RP	071-0644-02
AFJ31C1E-CFV	208/230	1	5.4	40	6	1.2		014-0064-10	040-0166-29	RP	
AFJ31C2E-CFV	208/230	1	7.5	44	6	1.2		014-0064-10	040-0166-29	RP	
AFJ37C1E-CFV	208/230	1	6.2	40	6	1.2		014-0064-10	040-0166-29	RP	
AFJ37C2E-CFV	208/230	1	8	46	6	1.2		014-0064-10	040-0166-29	RP	
AFT12C1-IAA	115	1	5	30	6.51	0.99	014-0053-18		040-0150-06	RC	071-0603-14

† ‡ § \* See Section F Introduction for more information.

FA1

**Electrical Data - A-Line**

Model	Volts	PH	Max RLA	LRA	Resistance		Start Cap P/N †	Run Cap P/N ‡	Relay P/N §	Part Type*	Protector P/N
					Start or Line/Line†	Run					
AFT12C1E-IAA	115	1	5.1	30	6.51	0.99	014-0053-21		040-0163-08	RC	071-0603-08
AFT12C1E-IAV	208/230	1	3.5	21.5	6.4	3.54	014-0059-09		040-0163-01	RC	071-0603-01
AFT18C1E-IAA	115	1	7.9	51	4.25	0.7	014-0053-26		040-0163-07	RC	071-0603-11
AFT18C1E-IAV	208/230	1	4.1	30	9	2.3	014-0053-30		040-0163-02	RC	071-0603-03
AFT22C1E-CFV	208/230	1	3.7	32.5	5.3	2.1	014-0058-31	014-0064-09	040-0166-39	RP	
AFT22C1E-IAA	115	1	9.2	55	3.8	0.54	014-0053-18		040-0172-00	RC	071-0605-00
AFT26C1E-CFA	115	1	8.8	72	4.03	0.6	014-0058-32	014-0064-11	040-0166-37	RP	
AFT26C1E-CFV	208/230	1	4.6	32.2	5.3	2.3		014-0064-09	040-0166-13	RP	
AFT29C1E-CFA	115	1	9.7	74	3.91	0.49	014-0058-38	014-0064-11	040-0166-37	RP	
AFT29C1E-CFV	208/230	1	5	33	5.3	2.3	014-0058-31	014-0064-09	040-0166-13	RP	
ARB10C3-SAA	115	1	2.5	17	14.85	3.3			040-0162-08	RC	071-0561-18
ARB13C3-SAA	115	1	2.8	20	10.5	2.7			040-0162-08	RC	071-0561-25
ARB13C3E-IAA	115	1	2.8	15.1	10.7	3	014-0053-18		040-0150-16	RC	071-0561-25
ARB13C3E-SAA	115	1	2.8	20	10.5	2.7			040-0162-08	RC	071-0561-25
ARB17C3-SAA	115	1	3.8	23	13.2	2.4			040-0162-11	RC	071-0561-09
ARB17C3E-IAA	115	1	3.5	19.3	9.1	2.4	014-0053-18		040-0150-15	RC	071-0561-09
ARB17C3E-SAA	115	1	3.8	23	13.2	2.4			040-0162-11	RC	071-0561-09
ARB21C3-IAA	115	1	4.6	26.5	8	1.4	014-0053-18		040-0150-19	RC	071-0561-01
ARB26C3-IAA	115	1	5	29	7.3	1.4	014-0059-14		040-0150-24	RC	071-0561-26
ARB26C3-IAV	208/230	1	3.1	15.5	21.35	5.1	014-0059-13		040-0163-00	RC	071-0561-09
ARE25C3-SAA	115	1	4.5	25	18.45	2			040-0162-01	RC	071-0561-23
ARE25C3E-IAA	115	1	4.7	21.5	8.3	2	014-0053-18		040-0150-10	RC	071-0561-23
ARE25C3E-SAA	115	1	4.5	25	18.45	2			040-0162-01	RC	071-0561-23
ARE27C3-IAA	115	1	4.9	25	7.4	1.55	014-0053-18		040-0150-02	RC	071-0561-23
ARE27C3-SAA	115	1	5	31	11.1	1.55			040-0162-07	RC	071-0561-23

† ‡ § \* See Section F Introduction for more information.  
FA2

### Electrical Data - A-Line

Model	Volts	PH	Max RLA	LRA	Resistance		Start Cap P/N †	Run Cap P/N ‡	Relay P/N §	Part Type*	Protector P/N
					Start or Line/Line†	Run					
ARE27C3E-IAA	115	1	4.9	25	7.4	1.55	014-0053-18		040-0150-02	RC	071-0561-23
ARE27C3E-SAA	115	1	5	31	11.1	1.55			040-0162-07	RC	071-0561-23
ARE29C4E-IAA	115	1	3.9	28.5	6.14	1.24	014-0053-18		040-0150-19	RC	071-0561-21
ARE34C4E-IAA	115	1	4.6	37	6.1	0.96	014-0053-21		040-0150-06	RC	071-0561-50
ARE35C3-IAA	115	1	7	34.6	9	1.05	014-0053-18		040-0150-20	RC	071-0561-03
ARE35C3-IAV	208/230	1	3.6	18.2	25.6	4.7	014-0059-13		040-0150-25	RC	071-0561-01
ARE36C3-IAA	115	1	6.7	29	7.3	1.2	014-0059-01		040-0150-01	RC	071-0561-16
ARE36C3-SAA	115	1	6.5	34	13.55	1.4			040-0162-03	RC	071-0561-16
ARE37C3-IAA	115	1	7.2	29	7.3	1.2	014-0053-18		040-0150-01	RC	071-0561-16
ARE37C3-SAA	115	1	7.2	35	13.65	1.2			040-0162-03	RC	071-0561-16
ARE37C3E-IAA	115	1	7.2	29	7.3	1.2	014-0053-21		040-0150-01	RC	071-0561-16
ARE37C3E-IAV	208/230	1	3.4	17.3	21.4	4.8	014-0053-30		040-0150-04	RC	071-0561-00
ARE37C3E-SAA	115	1	7.2	35	13.65	1.2			040-0162-03	RC	071-0561-16
ARE40C4E-IAA	115	1	7	37	6.1	0.96	014-0053-25		040-0150-33	RC	071-0561-03
ARE41C3-IAA	115	1	7.5	37.5	10.6	1	014-0053-21		040-0150-06	RC	071-0561-32
ARE41C3-SAA	115	1	4.7	41	8.8	1.1			040-0162-14	RC	071-0561-17
ARE41C3E-IAA	115	1	7.5	37.5	10.6	1	014-0053-21		040-0150-06	RC	071-0561-32
ARE41C3E-IAV	208/230	1	3.9	23.8	21.25	3.4	014-0053-29		040-0150-18	RC	071-0561-00
ARE43C3-IAA	115	1	7.1	29	7.3	1.2	014-0053-18		040-0150-01	RC	071-0561-17
ARE46C4E-IAA	115	1	9	40	5.5	0.86	014-0053-25		040-0150-11	RC	071-0561-51
ARE47C3-IAA	115	1	7	38.5	5.62	0.85	014-0053-26		040-0150-01	RC	071-0561-17
ARE47C3-IAV	208/230	1	4.5	25.8	21.86	2.92	014-0053-29		040-0150-13	RC	071-0561-00
ARE59C3-CAA	115	1	8	36	7.5	1.2	014-0058-37	014-0064-10	040-0166-45	RP	071-0561-07
ARE59C3-CAV	208/230	1	4	25.9	10.45	3.05	014-0058-25	014-0064-09	040-0166-30	RP	071-0561-10
ARJ10K1-CAV	208/230	1	7	37	7.6	1.8	014-0058-31	014-0064-10	040-0166-27	RP	071-0563-00

† ‡ § \* See Section F Introduction for more information.

FA3



**Electrical Data - A-Line**

Model	Volts	PH	Max RLA	LRA	Resistance		Start Cap P/N †	Run Cap P/N †	Relay P/N §	Part Type*	Protector P/N
					Start or Line/Line†	Run					
ARJ10K1-TFD	440/480	3	2.1	10	18.6	0					
ARJ11K1-CAV	208/230	1	7.3	40	8.1	1.45	014-0058-25	014-0064-03	040-0166-24	RP	071-0604-05
ARJ11K1E-CAV	208/230	1	7.4	43	8.1	1.45	014-0058-25	014-0064-33	040-0166-24	RP	071-0604-04
ARJ11K1E-TFD	440/480	3	2.3	13	14.87	0					
ARJ11K2-CAV	208/230	1	8.5	41	8.1	1.45	014-0058-25	014-0064-33	040-0166-24	RP	071-0604-11
ARJ11K2E-CAV	208/230	1	8.5	41	8.1	1.45	014-0058-25	014-0064-33	040-0166-24	RP	071-0604-11
ARJ13K1-CAB	230	1	6	40	5.4	1.75	014-0058-31	014-0064-10	040-0166-05	RP	071-C100-10
ARJ84C1-IAA	115	1	13.6	72	2.85	0.44	014-0036-23		040-0166-38	RP	071-0605-01
ARJ84C1-IAV	208/230	1	7.2	38	11.2	2	014-0058-31		040-0172-02	RC	071-0604-03
ARJ84C1E-IAV	208/230	1	7.4	42	8.09	1.4	014-0058-31		040-0172-02	RC	071-0604-03
ARJ84C1E-TFD	440/480	3	1.8	10	18.6	0					
ARJ84C2-IAA	115	1	11.4	73	2.85	0.44	014-0036-23		040-0166-38	RP	071-0605-01
ARJ84C2-IAV	208/230	1	8	42	8.09	1.4	014-0058-31		040-0172-02	RC	071-0604-11
ARJ84C2E-IAV	208/230	1	8	42	8.09	1.4	014-0058-31		040-0172-02	RC	071-0604-11
ART51C1-IAA	115	1	9.3	36	3.4	1.05	014-0053-21		040-0163-04	RC	071-0603-02
ART51C1E-IAA	115	1	9.3	36	3.4	1.05	014-0038-04		040-0163-04	RC	071-0603-02
ART51C1E-IAV	208/230	1	5	30	9	2.3	014-0058-18		040-0163-02	RC	071-0603-09
ART62C1-IAA	115	1	10.3	51	4.25	0.7	014-0053-25		040-0163-05	RC	071-0603-05
ART62C1E-IAA	115	1	10.2	51	4.25	0.7	014-0053-25		040-0163-05	RC	071-0603-05
ART62C1E-IAV	208/230	1	5.4	30	9	2.3	014-0058-18		040-0163-02	RC	071-0603-07
ART64C1E-IAA	115	1	11	51	4.25	0.7	014-0053-25		040-0163-07	RC	071-0603-10
ART64C1E-IAV	208/230	1	6	30	16	2.21			040-0163-02	RC	071-0603-15
ART69C1-IAA	115	1	13	55	4.1	0.54	014-0058-32		040-0172-03	RC	071-0605-05
ART69C1-IAV	208/230	1	6.1	30	9	2.3	014-0053-30		040-0163-02	RC	071-0603-13
ART82C1-CAA	115	1	11.8	72	4.15	0.6	014-0058-32	014-0064-13	040-0166-37	RP	071-0605-03

† ‡ § \* See Section F Introduction for more information.  
FA4

**Electrical Data - A-Line**

Model	Volts	PH	Max RLA	LRA	Resistance		Start Cap P/N †	Run Cap P/N ‡	Relay P/N §	Part Type*	Protector P/N
					Start or Line/Line†	Run					
ART82C1-CAV	208/230	1	5.9	30	9.06	2.94	014-0058-21	014-0064-09	040-0166-27	RP	071-0604-01
ART82C1-CFB	230	1	5.1	31	11.6	2.5	014-0058-31	014-0064-09	040-0166-04	RP	
ART97C1-CAA	115	1	14	71	3.944	0.461	014-0058-38	014-0064-11	040-0166-03	RP	071-0605-02
ART97C1-CAV	208/230	1	7	34	9.68	1.97	014-0058-21	014-0064-09	040-0166-27	RP	071-0604-08
ART97C1-PAA	115	1	11.2	50	6.28	0.58	014-0036-13	014-0064-11	040-0166-37	RP	071-0605-02
ART97C1-PAV	208/230	1	5.6	31.5			014-0036-13	014-0064-10	040-0166-27	RP	071-0604-06
ASB12C3E-IAA	115	1	5.2	26.5	8	1.4	014-0053-26		040-0150-19	RC	071-0561-01
ASB14C3E-IAA	115	1	6.8	29.75	7.3	1.2	014-0053-18		040-0150-01	RC	071-0561-26
ASE19C3E-IAA	115	1	8	34.6	9	1.05	014-0053-18		040-0150-20	RC	071-0561-21
ASE19C4E-IAA	115	1	5.6	26.5	6.14	1.24	014-0053-18		040-0150-32	RC	071-0561-21
ASE20C4E-CAA	115	1	5.5	30.5	6.14	1.24	014-0058-32	014-0064-10	040-0166-21	RP	071-0561-21
ASE20C4E-IAA	115	1	5.2	26.5	6.14	1.24	014-0053-26		040-0150-19	RC	071-0561-21
ASE21C3E-IAA	115	1	7	29	7.3	1.2	014-0053-26		040-0150-01	RC	071-0561-21
ASE24C3E-IAA	115	1	6	29	7.3	1.2	014-0053-26				071-0561-07
ASE24C3E-IAV	208/230	1	4.2	16.8	7.48	4.55	014-0059-09		040-0150-04	RC	071-0561-29
ASE26C4E-CAA	115	1	7.5	38	6.1	0.96	014-0036-28	014-0064-11	040-0166-21	RP	071-0561-03
ASE26C4E-IAA	115	1	7.5	38	6.1	0.96	014-0053-21		040-0163-04	RC	071-0561-03
ASE32C3E-CAA	115	1	9.2	33.6	7.3	1.2	014-0058-25	014-0064-10	040-0166-45	RP	071-0561-07
ASE32C3E-CAV	208/230	1	4.9	24.8	11.6	3.2	014-0058-31	014-0064-09	040-0166-13	RP	071-0561-12
ASE35C4E-CAA	115	1	12	51	5.2	0.67	014-0036-28	014-0064-12	040-0166-37	RP	071-0561-49
ASE35C4E-IAA	115	1	12	51	5.2	0.67	014-0053-21		040-0150-11	RC	071-0561-49
ASJ58C1E-CAV	208/230	1	8.4	34	7.6	1.8	014-0058-31	014-0064-10	040-0166-18	RP	071-0563-00
AST40C1E-IAA	115	1	13	55	3.8	0.54	014-0058-32		040-0172-03	RC	071-0605-05
AST40C1E-IAV	208/230	1	6.9	30	16	2.21	014-0058-31		040-0163-02	RC	071-0603-13
AST45C1E-CAV	208/230	1	6.5	30	9.06	2.94	014-0058-21	014-0064-09	040-0166-27	RP	071-0604-01

† ‡ § \* See Section F Introduction for more information.

FA5

**Electrical Data - A-Line**

Model	Volts	PH	Max RLA	LRA	Resistance		Start Cap P/N ‡	Run Cap P/N ‡	Relay P/N §	Part Type*	Protector P/N
					Start or Line/Line†	Run					
AST45C1E-IAA	115	1	15	55	4.1	0.54	014-0058-32		040-0172-03	RC	071-0605-03
AST54C1E-CAA	115	1	15	71	3.944	0.461	014-0058-38	014-0064-11	040-0166-03	RP	071-0605-04
AST54C1E-CAV	208/230	1	5.8	34	9.68	1.97	014-0058-21	014-0064-09	040-0166-27	RP	071-0604-07

† ‡ § \* See Section F Introduction for more information.  
FA6

### Electrical Data - Welded Compressors

Model	Volts	PH	Max RLA	LRA	Resistance		Start Cap P/N ‡	Run Cap P/N ‡	Relay P/N §	Part Type*	Protector P/N
					Run	Start or Line/Line †					
AFB04C3E-SAA	115	1	2	20	2.7	10.5			040-0162-13	RC	071-0561-13
AFB05C3E-IAA	115	1	2.8	26.5	1.9	8.5	014-0053-21		040-0150-05	RC	071-0561-08
AFB05C3E-SAA	115	1	2.7	27.5	1.9	8.5			040-0162-05	RC	071-0561-08
AFB06C3E-IAA	115	1	3.1	25	1.55	7.4	014-0053-26		040-0150-02	RC	071-0561-11
AFB09C3E-IAA	115	1	4.8	34.6	1.05	9	014-0053-26		040-0150-20	RC	071-0561-15
AFB09C3E-IAB	230	1	1.7	15	5.85	36	014-0059-13		040-0150-03	RC	071-0561-30
AFE06C4E-IAA	115	1	3.1	28.5	1.24	6.14	014-0053-18		040-0150-19	RC	071-0561-29
AFE07C3E-IAA	115	1	4.4	29	1.3	9	014-0053-26		040-0150-01	RC	071-0561-02
AFE08C4E-IAA	115	1	3.9	26.5	1.24	6.14	014-0053-18		040-0150-31	RC	071-0561-23
AFE10C3E-IAA	115	1	4.9	38	1.2	9	014-0053-26		040-0150-11	RC	071-0561-24
AFE11C3E-IAA	115	1	5.6	29	1.2	7.3	014-0053-18		040-0150-01	RC	071-0561-16
AFE11C4E-IAA	115	1	4.2	26.5	1.24	6.14	014-0053-18		040-0150-19	RC	071-0561-21
AFE12C3E-IAA	115	1	4.8	33	0.96	6.1	014-0053-21		040-0150-06	RC	071-0561-28
AFE13C3E-IAA	115	1	5.8	33	0.96	6.1	014-0053-21		040-0150-06	RC	071-0561-03
AFE13C3E-IAV	208/230	1	3.2	21.7	3.4	21.9	014-0059-13		040-0150-14	RC	071-0561-04
AFE13C4E-IAA	115	1	5.6	37.5	0.96	6.1	014-0053-21		040-0150-06	RC	071-0561-47
AFE17C4E-CAA	115	1	7.8	41.5	0.77	4.5	014-0036-28	014-0064-12	040-0166-21	RP	071-0561-48
AFE17C4E-IAA	115	1	7.8	41.5	0.77	4.5	014-0053-21		040-0150-11	RC	071-0561-48
AFJ23C1-IAA	115	1	7.2	59	0.611	4.771	014-0036-24		040-0166-38	RP	071-0605-03
AFJ23C2-IAA	115	1	9.2	54	0.611	4.771	014-0036-24		040-0166-38	RP	071-0644-02
AFJ31C1E-CFV	208/230	1	5.4	40	1.2	6		014-0064-10	040-0166-29	RP	
AFJ31C2E-CFV	208/230	1	7.5	44	1.2	6		014-0064-10	040-0166-29	RP	
AFJ37C1E-CFV	208/230	1	6.2	40	1.2	6		014-0064-10	040-0166-29	RP	
AFJ37C2E-CFV	208/230	1	8	46	1.2	6		014-0064-10	040-0166-29	RP	
AFT12C1-IAA	115	1	5	30	0.99	6.51	014-0053-18		040-0150-06	RC	071-0603-14
AFT12C1E-IAA	115	1	5.1	30	0.99	6.51	014-0053-21		040-0163-08	RC	071-0603-08

† ‡ § \* See Section F Introduction for more information.

FB1

### Electrical Data - Welded Compressors

Model	Volts	PH	Max RLA	LRA	Resistance		Start Cap P/N ‡	Run Cap P/N ‡	Relay P/N §	Part Type*	Protector P/N
					Run	Start or Line/Line †					
AFT12C1E-IAV	208/230	1	3.5	21.5	3.54	6.4	014-0059-09		040-0163-01	RC	071-0603-01
AFT18C1E-IAA	115	1	7.9	51	0.7	4.25	014-0053-26		040-0163-07	RC	071-0603-11
AFT18C1E-IAV	208/230	1	4.1	30	2.3	9	014-0053-30		040-0163-02	RC	071-0603-03
AFT22C1E-CFV	208/230	1	3.7	32.5	2.1	5.3	014-0058-31	014-0064-09	040-0166-39	RP	
AFT22C1E-IAA	115	1	9.2	55	0.54	3.8	014-0053-18		040-0172-00	RC	071-0605-00
AFT26C1E-CFA	115	1	8.8	72	0.6	4.03	014-0058-32	014-0064-11	040-0166-37	RP	
AFT26C1E-CFV	208/230	1	4.6	32.2	2.3	5.3		014-0064-09	040-0166-13	RP	
AFT29C1E-CFA	115	1	9.7	74	0.49	3.91	014-0058-38	014-0064-11	040-0166-37	RP	
AFT29C1E-CFV	208/230	1	5	33	2.3	5.3	014-0058-31	014-0064-09	040-0166-13	RP	
ARB10C3-SAA	115	1	2.5	17	3.3	14.85			040-0162-08	RC	071-0561-18
ARB13C3-SAA	115	1	2.8	20	2.7	10.5			040-0162-08	RC	071-0561-25
ARB13C3E-IAA	115	1	2.8	15.1	3	10.7	014-0053-18		040-0150-16	RC	071-0561-25
ARB13C3E-SAA	115	1	2.8	20	2.7	10.5			040-0162-08	RC	071-0561-25
ARB17C3-SAA	115	1	3.8	23	2.4	13.2			040-0162-11	RC	071-0561-09
ARB17C3E-IAA	115	1	3.5	19.3	2.4	9.1	014-0053-18		040-0150-15	RC	071-0561-09
ARB17C3E-SAA	115	1	3.8	23	2.4	13.2			040-0162-11	RC	071-0561-09
ARB21C3-IAA	115	1	4.6	26.5	1.4	8	014-0053-18		040-0150-19	RC	071-0561-01
ARB26C3-IAA	115	1	5	29	1.4	7.3	014-0059-14		040-0150-24	RC	071-0561-26
ARB26C3-IAV	208/230	1	3.1	15.5	5.1	21.35	014-0059-13		040-0163-00	RC	071-0561-09
ARE25C3-SAA	115	1	4.5	25	2	18.45			040-0162-01	RC	071-0561-23
ARE25C3E-IAA	115	1	4.7	21.5	2	8.3	014-0053-18		040-0150-10	RC	071-0561-23
ARE25C3E-SAA	115	1	4.5	25	2	18.45			040-0162-01	RC	071-0561-23
ARE27C3-IAA	115	1	4.9	25	1.55	7.4	014-0053-18		040-0150-02	RC	071-0561-23
ARE27C3-SAA	115	1	5	31	1.55	11.1			040-0162-07	RC	071-0561-23
ARE27C3E-IAA	115	1	4.9	25	1.55	7.4	014-0053-18		040-0150-02	RC	071-0561-23
ARE27C3E-SAA	115	1	5	31	1.55	11.1			040-0162-07	RC	071-0561-23

† ‡ § \* See Section F Introduction for more information.  
FB2

### Electrical Data - Welded Compressors

Model	Volts	PH	Max RLA	LRA	Resistance		Start Cap P/N ‡	Run Cap P/N ‡	Relay P/N §	Part Type*	Protector P/N
					Run	Start or Line/Line †					
ARE29C4E-IAA	115	1	3.9	28.5	1.24	6.14	014-0053-18		040-0150-19	RC	071-0561-21
ARE34C4E-IAA	115	1	4.6	37	0.96	6.1	014-0053-21		040-0150-06	RC	071-0561-50
ARE35C3-IAA	115	1	7	34.6	1.05	9	014-0053-18		040-0150-20	RC	071-0561-03
ARE35C3-IAV	208/230	1	3.6	18.2	4.7	25.6	014-0059-13		040-0150-25	RC	071-0561-01
ARE36C3-IAA	115	1	6.7	29	1.2	7.3	014-0059-01		040-0150-01	RC	071-0561-16
ARE36C3-SAA	115	1	6.5	34	1.4	13.55			040-0162-03	RC	071-0561-16
ARE37C3-IAA	115	1	7.2	29	1.2	7.3	014-0053-18		040-0150-01	RC	071-0561-16
ARE37C3-SAA	115	1	7.2	35	1.2	13.65			040-0162-03	RC	071-0561-16
ARE37C3E-IAA	115	1	7.2	29	1.2	7.3	014-0053-21		040-0150-01	RC	071-0561-16
ARE37C3E-IAV	208/230	1	3.4	17.3	4.8	21.4	014-0053-30		040-0150-04	RC	071-0561-00
ARE37C3E-SAA	115	1	7.2	35	1.2	13.65			040-0162-03	RC	071-0561-16
ARE40C4E-IAA	115	1	7	37	0.96	6.1	014-0053-25		040-0150-33	RC	071-0561-03
ARE41C3-IAA	115	1	7.5	37.5	1	10.6	014-0053-21		040-0150-06	RC	071-0561-32
ARE41C3-SAA	115	1	4.7	41	1.1	8.8			040-0162-14	RC	071-0561-17
ARE41C3E-IAA	115	1	7.5	37.5	1	10.6	014-0053-21		040-0150-06	RC	071-0561-32
ARE41C3E-IAV	208/230	1	3.9	23.8	3.4	21.25	014-0053-29		040-0150-18	RC	071-0561-00
ARE43C3-IAA	115	1	7.1	29	1.2	7.3	014-0053-18		040-0150-01	RC	071-0561-17
ARE46C4E-IAA	115	1	9	40	0.86	5.5	014-0053-25		040-0150-11	RC	071-0561-51
ARE47C3-IAA	115	1	7	38.5	0.85	5.62	014-0053-26		040-0150-01	RC	071-0561-17
ARE47C3-IAV	208/230	1	4.5	25.8	2.92	21.86	014-0053-29		040-0150-13	RC	071-0561-00
ARE59C3-CAA	115	1	8	36	1.2	7.5	014-0058-37	014-0064-10	040-0166-45	RP	071-0561-07
ARE59C3-CAV	208/230	1	4	25.9	3.05	10.45	014-0058-25	014-0064-09	040-0166-30	RP	071-0561-10
ARJ10K1-CAV	208/230	1	7	37	1.8	7.6	014-0058-31	014-0064-10	040-0166-27	RP	071-0563-00
ARJ10K1-TFD	440/480	3	2.1	10	0	18.6					
ARJ11K1-CAV	208/230	1	7.3	40	1.45	8.1	014-0058-25	014-0064-03	040-0166-24	RP	071-0604-05
ARJ11K1E-CAV	208/230	1	7.4	43	1.45	8.1	014-0058-25	014-0064-33	040-0166-24	RP	071-0604-04

† ‡ § \* See Section F Introduction for more information.

FB3

### Electrical Data - Welded Compressors

Model	Volts	PH	Max RLA	LRA	Resistance		Start Cap P/N ‡	Run Cap P/N ‡	Relay P/N §	Part Type*	Protector P/N
					Run	Start or Line/Line †					
ARJ11K1E-TFD	440/480	3	2.3	13	0	14.87					
ARJ11K2-CAV	208/230	1	8.5	41	1.45	8.1	014-0058-25	014-0064-33	040-0166-24	RP	071-0604-11
ARJ11K2E-CAV	208/230	1	8.5	41	1.45	8.1	014-0058-25	014-0064-33	040-0166-24	RP	071-0604-11
ARJ13K1-CAB	230	1	6	40	1.75	5.4	014-0058-31	014-0064-10	040-0166-05	RP	071-C100-10
ARJ84C1-IAA	115	1	13.6	72	0.44	2.85	014-0036-23		040-0166-38	RP	071-0605-01
ARJ84C1-IAV	208/230	1	7.2	38	2	11.2	014-0058-31		040-0172-02	RC	071-0604-03
ARJ84C1E-IAV	208/230	1	7.4	42	1.4	8.09	014-0058-31		040-0172-02	RC	071-0604-03
ARJ84C1E-TFD	440/480	3	1.8	10	0	18.6					
ARJ84C2-IAA	115	1	11.4	73	0.44	2.85	014-0036-23		040-0166-38	RP	071-0605-01
ARJ84C2-IAV	208/230	1	8	42	1.4	8.09	014-0058-31		040-0172-02	RC	071-0604-11
ARJ84C2E-IAV	208/230	1	8	42	1.4	8.09	014-0058-31		040-0172-02	RC	071-0604-11
ART51C1-IAA	115	1	9.3	36	1.05	3.4	014-0053-21		040-0163-04	RC	071-0603-02
ART51C1E-IAA	115	1	9.3	36	1.05	3.4	014-0038-04		040-0163-04	RC	071-0603-02
ART51C1E-IAV	208/230	1	5	30	2.3	9	014-0058-18		040-0163-02	RC	071-0603-09
ART62C1-IAA	115	1	10.3	51	0.7	4.25	014-0053-25		040-0163-05	RC	071-0603-05
ART62C1E-IAA	115	1	10.2	51	0.7	4.25	014-0053-25		040-0163-05	RC	071-0603-05
ART62C1E-IAV	208/230	1	5.4	30	2.3	9	014-0058-18		040-0163-02	RC	071-0603-07
ART64C1E-IAA	115	1	11	51	0.7	4.25	014-0053-25		040-0163-07	RC	071-0603-10
ART64C1E-IAV	208/230	1	6	30	2.21	16			040-0163-02	RC	071-0603-15
ART69C1-IAA	115	1	13	55	0.54	4.1	014-0058-32		040-0172-03	RC	071-0605-05
ART69C1-IAV	208/230	1	6.1	30	2.3	9	014-0053-30		040-0163-02	RC	071-0603-13
ART82C1-CAA	115	1	11.8	72	0.6	4.15	014-0058-32	014-0064-13	040-0166-37	RP	071-0605-03
ART82C1-CAV	208/230	1	5.9	30	2.94	9.06	014-0058-21	014-0064-09	040-0166-27	RP	071-0604-01
ART82C1-CFB	230	1	5.1	31	2.5	11.6	014-0058-31	014-0064-09	040-0166-04	RP	
ART97C1-CAA	115	1	14	71	0.461	3.944	014-0058-38	014-0064-11	040-0166-03	RP	071-0605-02
ART97C1-CAV	208/230	1	7	34	1.97	9.68	014-0058-21	014-0064-09	040-0166-27	RP	071-0604-08

† ‡ § \* See Section F Introduction for more information.  
FB4

### Electrical Data - Welded Compressors

Model	Volts	PH	Max RLA	LRA	Resistance		Start Cap P/N ‡	Run Cap P/N ‡	Relay P/N §	Part Type*	Protector P/N
					Run	Start or Line/Line †					
ART97C1-PAA	115	1	11.2	50	0.58	6.28	014-0036-13	014-0064-11	040-0166-37	RP	071-0605-02
ASB12C3E-IAA	115	1	5.2	26.5	1.4	8	014-0053-26		040-0150-19	RC	071-0561-01
ASB14C3E-IAA	115	1	6.8	29.75	1.2	7.3	014-0053-18		040-0150-01	RC	071-0561-26
ASE19C3E-IAA	115	1	8	34.6	1.05	9	014-0053-18		040-0150-20	RC	071-0561-21
ASE19C4E-IAA	115	1	5.6	26.5	1.24	6.14	014-0053-18		040-0150-32	RC	071-0561-21
ASE20C4E-CAA	115	1	5.5	30.5	1.24	6.14	014-0058-32	014-0064-10	040-0166-21	RP	071-0561-21
ASE20C4E-IAA	115	1	5.2	26.5	1.24	6.14	014-0053-26		040-0150-19	RC	071-0561-21
ASE21C3E-IAA	115	1	7	29	1.2	7.3	014-0053-26		040-0150-01	RC	071-0561-21
ASE24C3E-IAA	115	1	6	29	1.2	7.3	014-0053-26				071-0561-07
ASE24C3E-IAV	208/230	1	4.2	16.8	4.55	7.48	014-0059-09		040-0150-04	RC	071-0561-29
ASE26C4E-CAA	115	1	7.5	38	0.96	6.1	014-0036-28	014-0064-11	040-0166-21	RP	071-0561-03
ASE26C4E-IAA	115	1	7.5	38	0.96	6.1	014-0053-21		040-0163-04	RC	071-0561-03
ASE32C3E-CAA	115	1	9.2	33.6	1.2	7.3	014-0058-25	014-0064-10	040-0166-45	RP	071-0561-07
ASE32C3E-CAV	208/230	1	4.9	24.8	3.2	11.6	014-0058-31	014-0064-09	040-0166-13	RP	071-0561-12
ASE35C4E-CAA	115	1	12	51	0.67	5.2	014-0036-28	014-0064-12	040-0166-37	RP	071-0561-49
ASE35C4E-IAA	115	1	12	51	0.67	5.2	014-0053-21		040-0150-11	RC	071-0561-49
ASJ58C1E-CAV	208/230	1	8.4	34	1.8	7.6	014-0058-31	014-0064-10	040-0166-18	RP	071-0563-00
AST40C1E-IAA	115	1	13	55	0.54	3.8	014-0058-32		040-0172-03	RC	071-0605-05
AST40C1E-IAV	208/230	1	6.9	30	2.21	16	014-0058-31		040-0163-02	RC	071-0603-13
AST45C1E-CAV	208/230	1	6.5	30	2.94	9.06	014-0058-21	014-0064-09	040-0166-27	RP	071-0604-01
AST45C1E-IAA	115	1	15	55	0.54	4.1	014-0058-32		040-0172-03	RC	071-0605-03
AST54C1E-CAA	115	1	15	71	0.461	3.944	014-0058-38	014-0064-11	040-0166-03	RP	071-0605-04
AST54C1E-CAV	208/230	1	5.8	34	1.97	9.68	014-0058-21	014-0064-09	040-0166-27	RP	071-0604-07
CF04K6E-PFV	208/230	1	9.6	59.2	1.107	3.044	014-0061-04	014-0064-06	040-0166-15	RP	071-0508-38
CF04K6E-TF5	200/230	3	6.8	52	0	1.71					071-0501-44
CF04K6E-TFD	380/460	3	3.3	26	0	7.4					071-0496-27

† ‡ § \* See Section F Introduction for more information.

FB5



### Electrical Data - Welded Compressors

Model	Volts	PH	Max RLA	LRA	Resistance		Start Cap P/N ‡	Run Cap P/N ‡	Relay P/N §	Part Type*	Protector P/N
					Run	Start or Line/Line †					
CF06K6E-PFV	208/230	1	11.4	59.2	1.107	3.044	014-0061-04	014-0064-06	040-0166-15	RP	071-0508-38
CF06K6E-TF5	200/230	3	7	52	0	1.71					071-0501-44
CF06K6E-TFD	380/460	3	3.7	25.4	0	7.4					071-0501-46
CF09K6E-PFV	208/230	1	16.7	87	0.715	2.82	014-0058-32	014-0064-08	040-0166-15	RP	071-0546-04
CF09K6E-TF5	200/230	3	10.2	72.2	0	1.256					071-0501-45
CF09K6E-TFD	380/460	3	5.5	35.8	0	4.95					071-0501-47
CF12K6E-PFV	208/230	1	20.5	105	0.553	1.979	014-0058-00	014-0064-14	040-0166-19	RP	071-0546-08
CF12K6E-TF5	200/230	3	12.3	85	0	0.945					071-0501-56
CF12K6E-TFD	380/460	3	6.6	42	0	3.78					071-0496-20
CF12K6E-TFE	575	3	5.4	35	0	5.99					071-0614-00
CP25K8E-PFV	208/230	1	11.3	51	2.1	1.04	014-0061-04	014-0064-06	040-0166-19	RP	071-0546-25
CR14K7-PFV	208/230	1	6.9	35	1.85	2.392	014-0058-32	014-0064-07	040-0166-15	RP	071-0546-19
CR16K6-PFJ	265	1	9	44	1.741	3.619	014-0058-31	014-0064-05	040-0166-15	RP	071-0508-34
CR16K6-PFV	208/230	1	9.6	49	1.268	3.661	014-0058-22	014-0064-05	040-0166-15	RP	071-0508-72
CR16K7-PFV	208/230	1	8.4	39	1.647	2.538	014-0058-32	014-0064-07	040-0166-15	RP	071-0546-10
CR16KQ-PFV	208/230	1	7.9	38	2.214	5.084	014-0058-03	014-0064-11	040-0166-15	RP	071-0521-17
CR18K6-PFJ	265	1	9.1	44	1.741	3.619	014-0058-31	014-0064-11	040-0166-15	RP	071-0508-34
CR18K6-PFV	208/230	1	10.4	49	1.268	3.661	014-0058-32	014-0064-05	040-0166-15	RP	071-0508-72
CR18K7-PFV	208/230	1	8.6	40	1.592	2.519	014-0058-32	014-0064-07	040-0166-15	RP	071-0546-20
CR18KQ-PFV	208/230	1	9	41	2.092	4.215	014-0058-03	014-0064-12	040-0166-15	RP	071-0521-18
CR18KQ-TF5	200/230	3	6.1	49	0	1.9					071-0501-60
CR18KQ-TFD	380/460	3	3.1	23	0	7.437					071-0501-63
CR18KQE-PFV	208/230	1	9	41	2.092	4.215	014-0058-03	014-0064-12	040-0166-15	RP	071-0521-18
CR18KQE-TF5	200/230	3	6.1	49	0	1.9					071-0501-60
CR18KQE-TFD	380/460	3	3.1	23	0	7.437					071-0501-63
CR19K7-PFV	208/230	1	10.2	43	1.491	2.698	014-0061-04	014-0064-06	040-0166-19	RP	071-0508-38

† ‡ § \* See Section F Introduction for more information.

FB6

### Electrical Data - Welded Compressors

Model	Volts	PH	Max RLA	LRA	Resistance		Start Cap P/N ‡	Run Cap P/N ‡	Relay P/N §	Part Type*	Protector P/N
					Run	Start or Line/Line †					
CR20K6-PFV	208/230	1	10.6	50	1.268	3.661	014-0061-04	014-0064-06	040-0166-19	RP	071-0508-72
CR20KQ-PFV	208/230	1	10.4	54	1.529	4.003	014-0058-32	014-0064-06	040-0166-15	RP	071-0521-14
CR20KQE-PFV	208/230	1	10.4	54	1.529	4.003	014-0058-32	014-0064-06	040-0166-15	RP	071-0521-14
CR21K7-PFV	208/230	1	11.3	51	1.322	2.538	014-0061-04	014-0064-06	040-0166-19	RP	071-0508-38
CR22K6-PFJ	265	1	9.9	55	1.332	3.807	014-0058-34	014-0064-06	040-0166-15	RP	071-0508-50
CR22K6-PFV	208/230	1	10.9	50	1.268	3.661	014-0061-04	014-0064-06	040-0166-19	RP	071-0508-72
CR22K6-TF5	200/230	3	7.5	51	0	1.77					071-0501-01
CR22K6-TFD	380/460	3	3.9	25	0	7.4					071-0501-00
CR22KQ-PFV	208/230	1	11.1	51.5	1.626	3.424	014-0058-03	014-0064-13	040-0166-44	RP	071-0521-16
CR22KQE-PFV	208/230	1	11.1	51.5	1.626	3.424	014-0058-03	014-0064-13	040-0166-44	RP	071-0521-16
CR23K7-PFV	208/230	1	10.8	49	1.251	2.026	014-0058-00	014-0064-08	040-0166-15	RP	071-0546-12
CR24K6-PFJ	265	1	10.9	58	1.346	2.646	014-0058-26	014-0064-13	040-0166-19	RP	071-0508-52
CR24K6-PFV	208/230	1	12.4	61	0.999	2.594	014-0058-03	014-0064-07	040-0166-15	RP	071-0508-35
CR24K6-TF5	200/230	3	7.7	55	0	1.609					071-0502-08
CR24K6-TFD	380/460	3	4	28	0	6.386					071-0502-00
CR24K7-PFV	208/230	1	12	60	1.163	2.101	014-0058-00	014-0064-08	040-0166-15	RP	071-0546-12
CR24KQ-PFV	208/230	1	13.6	70.5	0.862	3.337	014-0058-03	014-0064-13	040-0166-15	RP	071-0521-20
CR24KQ-TF5	200/230	3	7.5	51	0	1.97					071-0501-62
CR24KQ-TFD	380/460	3	3.7	25	0	7.4					071-0501-00
CR24KQE-PFV	208/230	1	13.6	70.5	0.862	3.337	014-0058-03	014-0064-13	040-0166-15	RP	071-0521-20
CR24KQE-TF5	200/230	3	7.5	51	0	1.97					071-0501-62
CR24KQE-TFD	380/460	3	3.7	25	0	7.4					071-0501-00
CR28K6-PFJ	265	1	13.9	73	0.986	3.649	014-0036-18	014-0064-13	040-0166-15	RP	071-0508-48
CR28K6-PFV	208/230	1	15.3	75	0.74	2.3	014-0061-04	014-0064-07	040-0166-19	RP	071-0521-02
CR28K6-TF5	200/230	3	10	68	0	1.3					071-0501-05
CR28K6-TFD	460	3	4.8	34	0	5.43					071-0502-12

† ‡ § \* See Section F Introduction for more information.

FB7

### Electrical Data - Welded Compressors

Model	Volts	PH	Max RLA	LRA	Resistance		Start Cap P/N ‡	Run Cap P/N ‡	Relay P/N §	Part Type*	Protector P/N
					Run	Start or Line/Line †					
CR28K7-PFV	208/230	1	13.6	73	0.847	2.131	014-0058-32	014-0064-13	040-0166-15	RP	071-0546-17
CR28K7-TF5	200/230	3	10	65.5	0	1.256					071-0477-06
CR28KQ-PFV	208/230	1	15	70.5	0.862	3.337	014-0058-03	014-0064-13	040-0166-15	RP	071-0521-20
CR28KQ-TF5	200/230	3	8.9	60.5	0	1.28					071-0501-62
CR28KQ-TFD	380/460	3	4.4	30	0	5.05					071-0501-00
CR28KQE-PFV	208/230	1	15	70.5	0.862	3.337	014-0058-03	014-0064-13	040-0166-15	RP	071-0521-20
CR28KQE-TF5	200/230	3	8.9	60.5	0	1.28					071-0501-62
CR28KQE-TFD	380/460	3	4.4	30	0	5.05					071-0501-00
CR30K6-PFJ	265	1	13.6	64	1.096	3.02	014-0058-32	014-0064-14	040-0166-15	RP	071-0508-63
CR30K6-PFV	208/230	1	16	82	0.715	2.82	014-0058-32	014-0064-07	040-0166-15	RP	071-0508-31
CR30K6-TF5	200/230	3	10.4	65.5	0	1.256					071-0477-06
CR30K6-TFD	460	3	4.9	33	0	4.95					071-0501-25
CR30KQ-PFV	208/230	1	15.4	78	0.82	3.045	014-0058-03	014-0064-13	040-0166-15	RP	071-0521-19
CR30KQ-TFD	380/460	3	4.7	32	0	4.96					071-0501-26
CR30KQE-PFV	208/230	1	15.4	78	0.82	3.045	014-0058-03	014-0064-13	040-0166-15	RP	071-0521-19
CR30KQE-TFD	380/460	3	4.7	32	0	4.96					071-0501-26
CR31K7-PFV	208/230	1	16.1	82	0.715	2.82	014-0058-32	014-0064-13	040-0166-15	RP	071-0508-31
CR31K7-TF5	200/230	3	9.1	66	0	1.256					071-0501-68
CR32K6-PFJ	265	1	15	83	0.91	2.955	014-0058-32	014-0064-13	040-0166-14	RP	071-0508-51
CR32K6-PFV	208/230	1	16.1	82	0.751	3.2	014-0058-32	014-0064-13	040-0166-14	RP	071-0492-02
CR32K6-TF5	200/230	3	10	70	0	1.133					071-0501-20
CR32K6-TFD	460	3	5.1	33	0	4.3					071-0501-25
CR32K6-TFE	575	3	3.8	27	0	7.48					071-0496-21
CR32KQ-PFV	208/230	1	17	83	0.721	2.775	014-0058-32		040-0166-15	RP	071-0521-11
CR32KQ-TF5	200/230	3	9.9	63	0	1.24					071-0501-59
CR32KQ-TFD	380/460	3	5.1	32	0	4.99					071-0501-64

† ‡ § \* See Section F Introduction for more information.  
FB8

### Electrical Data - Welded Compressors

Model	Volts	PH	Max RLA	LRA	Resistance		Start Cap P/N ‡	Run Cap P/N ‡	Relay P/N §	Part Type*	Protector P/N
					Run	Start or Line/Line †					
CR32KQE-PFV	208/230	1	17	83	0.721	2.775	014-0058-32		040-0166-15	RP	071-0521-11
CR32KQE-TF5	200/230	3	9.9	63	0	1.24					071-0501-59
CR32KQE-TFD	380/460	3	5.1	32	0	4.99					071-0501-64
CR33KQ-PFV	208/230	1	16	75	0.865	3.626	014-0058-00	014-0064-14	040-0166-14	RP	071-0508-77
CR33KQ-TF5	200/230	3	10.6	69	0	1.28					071-0501-36
CR33KQ-TFD	460	3	4.7	31.6	0	5.05					071-0501-35
CR33KQE-PFV	208/230	1	16	75	0.865	3.626	014-0058-00	014-0064-14	040-0166-14	RP	071-0508-77
CR33KQE-TF5	200/230	3	10.6	69	0	1.28					071-0501-36
CR33KQE-TFD	460	3	4.7	31.6	0	5.05					071-0501-35
CR34K6-PFV	208/230	1	16.6	96	0.639	1.911	014-0058-00	014-0064-29	040-0166-15	RP	071-0508-30
CR34KQ-PFV	208/230	1	16.7	84	0.74	3.352	014-0058-00	014-0064-14	040-0166-14	RP	071-0508-79
CR34KQ-TF5	200/230	3	11.8	67	0	1.24					071-0501-16
CR34KQ-TFD	460	3	5.4	29.2	0	5.85					071-0501-32
CR34KQE-PFV	208/230	1	16.7	84	0.74	3.352	014-0058-00	014-0064-14	040-0166-14	RP	071-0508-79
CR34KQE-TF5	200/230	3	11.8	67	0	1.24					071-0501-16
CR34KQE-TFD	460	3	5.4	29.2	0	5.85					071-0501-32
CR35K6-PFV	208/230	1	18	96	0.623	2.333	014-0058-00	014-0064-08	040-0166-15	RP	071-0508-30
CR35K6-TF5	200/230	3	11.4	75	0	1.058					071-0501-13
CR35K6-TFD	460	3	4.8	40	0	4.11					071-0496-13
CR35K6-TFE	575	3	4.1	31	0	6.5					071-0477-15
CR35K7-PFV	208/230	1	18.2	89	0.61	2.08	014-0058-00	014-0064-13	040-0166-15	RP	071-0508-78
CR36KQ-PFV	208/230	1	17.6	93	0.711	3.152	014-0058-00	014-0064-14	040-0166-14	RP	071-0508-78
CR36KQ-TF5	200/230	3	12.4	68	0	1.13					071-0501-38
CR36KQ-TFD	460	3	5.5	34.5	0	4.43					071-0501-37
CR36KQE-PFV	208/230	1	17.6	93	0.711	3.152	014-0058-00	014-0064-14	040-0166-14	RP	071-0508-78
CR36KQE-TF5	200/230	3	12.4	68	0	1.13					071-0501-38

† ‡ § \* See Section F Introduction for more information.

FB9

### Electrical Data - Welded Compressors

Model	Volts	PH	Max RLA	LRA	Resistance		Start Cap P/N ‡	Run Cap P/N ‡	Relay P/N §	Part Type*	Protector P/N
					Run	Start or Line/Line †					
CR36KQE-TFD	460	3	5.5	34.5	0	4.43					071-0501-37
CR37KQ-PFV	208/230	1	18.6	100	0.664	2.431	014-0058-00	014-0064-08	040-0166-19	RP	071-0508-12
CR37KQ-TF5	200/230	3	11.1	85	0	1.07					071-0501-31
CR37KQ-TFD	380/460	3	5.6	39	0	3.693					071-0496-09
CR37KQ-TFE	575	3	4.8	34.39	0	5.99					071-0614-02
CR37KQE-PFV	208/230	1	18.6	100	0.664	2.431	014-0058-00	014-0064-08	040-0166-19	RP	071-0508-12
CR37KQE-TF5	200/230	3	11.1	85	0	1.07					071-0501-31
CR37KQE-TFD	380/460	3	5.6	39	0	3.693					071-0496-09
CR38K6-PFV	208/230	1	19	105	0.553	1.979	014-0058-00	014-0064-14	040-0166-19	RP	071-0508-42
CR38K6-TF5	200/230	3	11.9	85	0	0.945					071-0502-09
CR38K6-TFD	380/460	3	5.9	42	0	3.78					071-0496-20
CR38K6-TFE	575	3	4.8	34	0	5.9					071-0477-12
CR41KQ-PFV	208/230	1	19.4	109.6	0.601	2.324	014-0058-00	014-0064-16	040-0166-27	RP	071-0508-12
CR41KQ-TF5	200/230	3	13.1	80	0	1.04					071-0501-33
CR41KQ-TFD	380/460	3	5.9	42	0	4.06					071-0501-29
CR41KQE-PFV	208/230	1	19.4	109.6	0.601	2.324	014-0058-00	014-0064-16	040-0166-27	RP	071-0508-12
CR41KQE-TF5	200/230	3	13.1	80	0	1.04					071-0501-33
CR41KQE-TFD	380/460	3	5.9	42	0	4.06					071-0501-29
CR42K6-PFV	208/230	1	20.4	102	0.585	2.37	014-0058-00	014-0064-14	040-0166-27	RP	071-0508-19
CR42K6-TF5	200/230	3	14	91	0	0.875					071-0501-18
CR42K6-TFD	460	3	6.4	42	0	3.45					071-0477-09
CR42K6-TFE	575	3	5.2	39	0	5.315					071-0477-14
CR47KQ-PFV	208/230	1	24.6	132	0.457	2.148	014-0058-00	014-0064-15	040-0166-18	RP	071-0546-07
CR47KQ-TF5	200/230	3	16.1	97	0	0.82					071-0501-53
CR47KQ-TFD	380/460	3	8.2	50	0	3.22					071-0501-57
CR47KQ-TFE	575	3	5.6	38.6	0	5.026					071-0614-01

† ‡ § \* See Section F Introduction for more information.  
FB10

### Electrical Data - Welded Compressors

Model	Volts	PH	Max RLA	LRA	Resistance		Start Cap P/N ‡	Run Cap P/N ‡	Relay P/N §	Part Type*	Protector P/N
					Run	Start or Line/Line †					
CR47KQE-PFV	208/230	1	24.6	132	0.457	2.148	014-0058-00	014-0064-15	040-0166-18	RP	071-0546-07
CR47KQE-TF5	200/230	3	16.1	97	0	0.82					071-0501-53
CR47KQE-TFD	380/460	3	8.2	50	0	3.22					071-0501-57
CR53KQ-PFV	208/230	1	28.9	140	0.424	2.022	014-0058-00	014-0064-18	040-0166-18	RP	071-0509-02
CR53KQ-TF5	200/230	3	18.2	107	0	0.705					071-0501-53
CR53KQ-TFD	380/460	3	9.1	55	0	2.77					071-0501-48
CR53KQ-TFE	575	3	6	45.6	0	4.4					071-0614-01
CR53KQE-PFV	208/230	1	28.9	140	0.424	2.022	014-0058-00	014-0064-18	040-0166-18	RP	071-0509-02
CR53KQE-TF5	200/230	3	18.2	107	0	0.705					071-0501-53
CR53KQE-TFD	380/460	3	9.1	55	0	2.77					071-0501-48
CR60K5-PFV	208/230	1	30.7	135	0.405	1.33	014-0058-00	014-0064-15	040-0166-27	RP	071-0508-09
CR60K5-TF5	200/230	3	19.6	105	0	0.79					071-0428-07
CR60K5-TFD	380/460	3	10.4	55	0	2.83					071-0428-02
CR60KQ-PFV	208/230	1	30.7	135	0.405	1.33	014-0058-00	014-0064-15	040-0166-27	RP	071-0508-09
CR60KQ-TFD	380/460	3	10.4	55	0	2.83					071-0428-02
CRN5-0500-PFV	208/230	1	34.3	142	0.382	1.36	014-0006-15	014-0064-17	040-0166-27	RP	071-0483-00
CRN5-0500-TF5	200/230	3	21.4	130	0	0.639					071-0526-00
CRN5-0500-TFD	380/460	3	9.6	65	0	2.47					071-0526-01
CRN5-0500-TFE	575	3	7.9	52	0	4.35					071-0428-05
CRNQ-0500-PFV	208/230	1	34.3	142	0.382	1.36	014-0006-15	014-0064-17	040-0166-27	RP	071-0483-00
CRNQ-0500-TF5	200/230	3	21.4	130	0	0.639					071-0526-00
CRNQ-0500-TFD	380/460	3	9.6	65	0	2.47					071-0526-01
CRNQ-0500-TFE	575	3	7.9	52	0	4.35					071-0428-05
CRNQ-050E-TF5	200/230	3	21.4	130	0	0.639					071-0526-00
CRNQ-050E-TFD	380/460	3	9.6	65	0	2.47					071-0526-01
CRP5-0450-PFV	208/230	1	30.7	135	0.405	1.33	014-0058-00	014-0064-15	040-0166-27	RP	071-0508-09

† ‡ § \* See Section F Introduction for more information.

FB11

### Electrical Data - Welded Compressors

Model	Volts	PH	Max RLA	LRA	Resistance		Start Cap P/N ‡	Run Cap P/N ‡	Relay P/N §	Part Type*	Protector P/N
					Run	Start or Line/Line †					
CRP5-0450-TF5	200/230	3	19.6	105	0	0.79					071-0428-07
CRP5-0450-TFD	380/460	3	10.4	55	0	2.83					071-0428-02
CRP5-0450-TFE	575	3	7	45	0	4.71					071-0428-11
CRPQ-0450-PFV	208/230	1	30.7	135	0.405	1.33	014-0058-00	014-0064-15	040-0166-27	RP	071-0508-09
CRPQ-0450-TF5	200/230	3	19.6	105	0	0.79					071-0428-07
CRPQ-0450-TFD	380/460	3	10.4	55	0	2.83					071-0428-02
CRPQ-0450-TFE	575	3	7	45	0	4.71					071-0428-11
CRT5-0450-PFV	208/230	1	30.7	135	0.405	1.33	014-0058-00	014-0064-15	040-0166-27	RP	071-0508-09
CRT5-0450-TF5	200/230	3	19.6	105	0	0.79					071-0428-07
CRT5-0450-TFD	380/460	3	10.4	55	0	2.83					071-0428-02
CRT5-0450-TFE	575	3	7	45	0	4.71					071-0428-11
CRTQ-0450-PFV	208/230	1	30.7	135	0.405	1.33	014-0058-00	014-0064-15	040-0166-27	RP	071-0508-09
CRTQ-0450-TF5	200/230	3	19.6	105	0	0.79					071-0428-07
CRTQ-0450-TFD	380/460	3	10.4	55	0	2.83					071-0428-02
CRTQ-0450-TFE	575	3	7	45	0	4.71					071-0428-11
CRTQ-045E-TF5	200/230	3	19.6	105	0	0.79					071-0428-07
CRTQ-045E-TFD	380/460	3	10.4	55	0	2.83					071-0428-02
CS08KQE-PFV	208/230	1	10.1	54	1.107	3.044	014-0058-32	014-0064-06	040-0166-15	RP	071-0508-38
CS10K6E-PFJ	265	1	8.6	55	1.332	3.807	014-0036-18	014-0064-06	040-0166-15	RP	071-0508-50
CS10K6E-PFV	208/230	1	10.9	56	1.107	3.044	014-0061-04	014-0064-06	040-0166-19	RP	071-0508-38
CS10K6E-TF5	200/230	3	7.5	51	0	1.77					071-0501-01
CS10K6E-TFD	380/460	3	3.6	25	0	7.4					071-0501-00
CS12K6E-PFJ	265	1	10.9	55	1.332	3.807	014-0036-18	014-0064-06	040-0166-15	RP	071-0508-50
CS12K6E-PFV	208/230	1	10.9	56	1.107	3.044	014-0061-04	014-0064-06	040-0166-19	RP	071-0508-38
CS12K6E-TF5	200/230	3	7.5	51	0	1.77					071-0501-01
CS13K6E-PFV	208/230	1	14.4	73	0.847	2.131	014-0058-00	014-0064-13	040-0166-15	RP	071-0546-17

† ‡ § \* See Section F Introduction for more information.  
FB12

### Electrical Data - Welded Compressors

Model	Volts	PH	Max RLA	LRA	Resistance		Start Cap P/N ‡	Run Cap P/N ‡	Relay P/N §	Part Type*	Protector P/N
					Run	Start or Line/Line†					
CS13K6E-TF5	200/230	3	9	66	0	1.256					071-0501-68
CS14K6E-PFJ	265	1	12.5	58	1.346	2.646	014-0061-04	014-0064-13	040-0166-19	RP	071-0508-52
CS14K6E-PFV	208/230	1	12.5	61	0.999	2.594	014-0058-03	014-0064-07	040-0166-15	RP	071-0508-35
CS14K6E-TF5	200/230	3	9.1	55	0	1.609					071-0502-08
CS14K6E-TFD	380/460	3	4.7	28	0	6.386					071-0502-00
CS16K6E-PFV	208/230	1	15.5	73	0.847	2.131	014-0061-16	014-0064-13			071-0546-17
CS17K6E-PFV	208/230	1	16	82	0.727	2.367	014-0058-00	014-0064-13	040-0166-14	RP	071-0521-03
CS18K6E-PFJ	265	1	13.6	64	1.096	3.02	014-0058-32	014-0064-14	040-0166-15	RP	071-0508-63
CS18K6E-PFV	208/230	1	16	82	0.715	2.82	014-0058-32	014-0064-07	040-0166-15	RP	071-0508-31
CS18K6E-TF5	200/230	3	8.8	65.5	0	1.256					071-0477-06
CS18K6E-TFD	460	3	4.7	33	0	4.95					071-0501-26
CS18K6E-TFE	575	3	4.4	25.4	0	7.48					071-0614-03
CS20K6E-PFV	208/230	1	18.6	96	0.623	2.333	014-0058-00	014-0064-08	040-0166-15	RP	071-0508-30
CS20K6E-TF5	200/230	3	11.4	75	0	1.058					071-0501-13
CS20K6E-TFD	460	3	5.1	40	0	4.11					071-0496-13
CS24K6E-PFV	208/230	1	23.9	121	0.5	2.302	014-0058-00	014-0064-14	040-0166-23	RP	071-0546-03
CS24K6E-TF5	200/230	3	14	105	0	0.853					071-0501-49
CS27K3E-TF5	200/230	3	15.6	82	0	0.994					071-0417-01
CS27K3E-TFD	380/460	3	8.4	41	0	3.96					071-0417-06
CS27K6E-PFV	208/230	1	23.9	121	0.5	2.302	014-0058-00	014-0064-14	040-0166-23	RP	071-0546-03
CS27K6E-TF5	200/230	3	13.4	105	0	0.853					071-0501-49
CS27K6E-TFD	460	3	8.4	52	0	3.413					071-0501-50
CS33K3E-PFV	208/230	1	30.7	125	0.44	2.1	014-0058-00	014-0064-16	040-0166-27	RP	071-0508-37
CS33K3E-TF5	200/230	3	20.7	90	0	0.853					071-0417-00
CS33K3E-TFC	208/230	3	20.7	90	0	0.853					071-0417-00
CS33K3E-TFD	380/460	3	9.9	45	0	3.413					071-0417-12

† ‡ § \* See Section F Introduction for more information.

FB13



### Electrical Data - Welded Compressors

Model	Volts	PH	Max RLA	LRA	Resistance		Start Cap P/N ‡	Run Cap P/N ‡	Relay P/N §	Part Type*	Protector P/N
					Run	Start or Line/Line †					
CS33K6E-PFV	208/230	1	30.7	125	0.424	2.022	014-0006-15	014-0064-17	040-0166-27	RP	071-0546-05
CS33K6E-TF5	200/230	3	18.7	102	0	0.853					071-0496-28
CS33K6E-TFD	460	3	9.9	48	0	3.413					071-0501-54
CTH1-0275-CSV	208/230	1	19.6			3.8	014-0058-03	014-0064-13	040-0001-84	RP	071-0582-00
CTH1-0275-TSC	208/230	3	14.1			0					071-0582-00
CTL1-0350-CSV	208/230	1	24.1			2.81	014-0058-13	014-0064-15	040-0001-86	RP	071-0582-00
CTL1-0350-TSC	208/230	3	17.6			0					071-0582-00
CTM1-0400-CSV	208/230	1	34.3			2.18	014-0058-04	014-0064-16	040-0001-83	RP	071-0582-00
CTM1-0400-TSC	208/230	3	22.1			0					071-0582-00
CTN1-0500-TSC	208/230	3	25.2			0					071-0582-00
CTN1-0501-CSV	208/230	1	35.7			2.02	014-0058-04	014-0064-17	040-0001-85	RP	071-0582-00
REBQ-0150-PFJ	265	1	7.4	39.6	1.97	5.37	014-0036-17	014-0064-12	040-0166-14	RP	071-0512-12
REBQ-0150-PFV	208/230	1	7.9	49.7	1.58	4.353		014-0064-05			071-0512-15
REKQ-0125-PFJ	265	1	6.9	40	1.97	5.37	014-0036-17	014-0064-12	040-0166-14	RP	071-0512-12
REKQ-0125-PFV	208/230	1	8.5	49.7	1.58	4.353		014-0064-05			071-0512-15
RF18C1E-IAA	115	1	12.9	66.3	0.455	2.245	014-0058-27		040-0168-03	RC	071-0127-06
RF18C1E-IAV	208/230	1	7.1	25	3.09	13.32			040-0168-06	RC	071-0329-26
RF18C2E-IAA	115	1	12.9	66.3	0.455	2.245	014-0058-27		040-0168-03	RC	071-0127-06
RF18C2E-IAV	208/230	1	7.1	25	3.09	13.32			040-0168-06	RC	071-0329-26
RF40C1E-CAA	115	1	15.4	64	0.51	2.8	014-0058-31	014-0064-08	040-0166-14	RP	071-0518-03
RF40C1E-CAV	208/230	1	6.1	24.1	2.1	18.3	014-0058-17	014-0064-00	040-0166-14	RP	071-0527-07
RF41C1E-CAA	115	1	15.4	76.5	0.415	3.22	014-0058-22	014-0064-07	040-0166-15	RP	071-0518-09
RF41C1E-CAV	208/230	1	7.9	40	1.65	6.3	014-0058-19	014-0064-02	040-0166-14	RP	071-0518-10
RF41C5E-CAA	115	1	15.4	64	0.51	2.8	014-0058-31	014-0064-08	040-0166-14	RP	071-0518-03
RF41C5E-CAV	208/230	1	7.9	40	1.65	6.3	014-0058-19	014-0064-02	040-0166-14	RP	071-0518-10
RF42C1E-CAA	115	1	16	72.5	0.409	5.39	014-0058-31	014-0064-05	040-0166-19	RP	071-0127-46

† ‡ § \* See Section F Introduction for more information.

FB14

### Electrical Data - Welded Compressors

Model	Volts	PH	Max RLA	LRA	Resistance		Start Cap P/N ‡	Run Cap P/N ‡	Relay P/N §	Part Type*	Protector P/N
					Run	Start or Line/Line†					
RF42C1E-CAV	208/230	1	8.4	46	1.36	4.45	014-0058-00	014-0064-10	040-0166-14	RP	071-0127-37
RFT12C1E-IAA	115	1	6.1	33.7	0.72	4.11	014-0059-14		040-0150-37	RC	071-0561-66
RFT12C1E-IAB	230	1	2.5	15.8	2.71	13.8	014-0059-09		040-0150-04	RC	071-0561-64
RFT22C1E-CAA	115	1	7.9	54.5	0.43	2.66	014-0058-36	014-0064-13	040-0166-21	RP	071-0645-01
RFT22C1E-IAA	115	1	7.9	54.5	0.43	2.66	014-0058-36		040-0172-03	RC	071-0645-00
RFT26C1E-CAA	115	1	10.8	66	0.04	2.6	014-0058-36	014-0064-13	040-0166-21	RP	071-0604-18
RFT26C1E-CAB	230	1	5.7	26	2.3	8.8	014-0058-31	014-0064-09	040-0166-26	RP	071-0647-09
RFT26C1E-IAA	115	1	10.8	66	0.04	2.6	014-0058-36		040-0172-03	RC	071-0605-10
RFT26C1E-IAB	230	1	5.7	26	2.3	8.8	014-0053-30		040-0150-34	RC	071-0561-28
RFT29C1E-CAA	115	1	13	66	0.4	2.6	014-0058-36	014-0064-13	040-0166-21	RP	071-0604-16
RFT29C1E-IAA	115	1	13	66	0.4	2.6	014-0058-36		040-0172-03	RC	071-0605-05
RFT32C1E-CAA	115	1	15	56	0.34	2.59	014-0058-36	014-0064-13	040-0166-37	RP	071-0605-09
RFT32C1E-IAA	115	1	15	56	0.34	2.59	014-0058-36		040-0166-37	RP	071-0605-08
RR10K1E-CAA	115	1	15	78	0.412	4.83	014-0058-26	014-0064-06	040-0166-14	RP	071-0127-30
RR10K1E-CAV	208/230	1	7.3	40	1.65	6.3	014-0058-19	014-0064-02	040-0166-14	RP	071-0127-05
RR10K2-CAA	115	1	16.9	78	0.412	4.83	014-0058-26	014-0064-06	040-0166-14	RP	071-0127-30
RR10K2-CAV	208/230	1	8.3	40	1.65	6.3	014-0058-19	014-0064-02	040-0166-14	RP	071-0127-05
RR10K2E-CAA	115	1	16.9	78	0.412	4.83	014-0058-26	014-0064-06	040-0166-14	RP	071-0127-30
RR10K2E-CAV	208/230	1	8.3	40	1.65	6.3	014-0058-19	014-0064-02	040-0166-14	RP	071-0127-05
RR12K1-PFV	208/230	1	7.1	35	1.96	4.89	014-0058-19	014-0064-04	040-0166-19	RP	071-0421-22
RR14K1-PFJ	265	1	6.9	35	2.84	5.25	014-0058-31	014-0064-05	040-0166-14	RP	071-0512-09
RR14K1-PFV	208/230	1	8.5	40	2.09	4.87	014-0058-19	014-0064-05	040-0166-19	RP	071-0512-04
RR16K1-PFJ	265	1	8.4	36.1	2.44	4.77	014-0036-16	014-0064-11	040-0166-15	RP	071-0432-16
RR16K1-PFV	208/230	1	9.5	43.3	1.52	4.39	014-0058-25	014-0064-05	040-0166-19	RP	071-0432-10
RR17K1-PFJ	265	1	8.2	44	2.16	4.06	014-0058-25	014-0064-12	040-0166-14	RP	071-0512-13
RR17K1-PFV	208/230	1	10.4	48.2	1.54	3.82	014-0058-25	014-0064-06	040-0166-37	RP	071-0432-10

† ‡ § \* See Section F Introduction for more information.

FB15

### Electrical Data - Welded Compressors

Model	Volts	PH	Max RLA	LRA	Resistance		Start Cap P/N ‡	Run Cap P/N ‡	Relay P/N §	Part Type*	Protector P/N
					Run	Start or Line/Line †					
RR17K1-TFC	208/230	3	6.5	41	0	2.4					071-0481-01
RR20K1-PFV	208/230	1	12.1	65	0.955	4.085	014-0061-18	014-0064-05	040-0166-19	RP	071-0432-15
RR81C1E-IAA	115	1	13.3	66.3	0.416	3.15	014-0058-22		040-0168-03	RC	071-0127-18
RR81C1E-IAV	208/230	1	7.9	33.5	1.55	7.92	014-0061-18		040-0168-01	RC	071-0329-07
RR81C2-IAA	115	1	15.2	66.3	0.416	3.15	014-0058-22		040-0168-03	RC	071-0127-18
RR81C2-IAV	208/230	1	9	33.5	1.55	7.92	014-0061-18		040-0168-01	RC	071-0329-07
RR81C2E-IAA	115	1	15.2	66.3	0.416	3.15	014-0058-22		040-0168-03	RC	071-0127-18
RR81C2E-IAV	208/230	1	9	33.5	1.55	7.92	014-0061-18		040-0168-01	RC	071-0329-07
RRG4-0100-PAA	115	1	13.2	60	0.551	4.8	014-0058-06	014-0064-05	040-0166-19	RP	071-0127-40
RRG4-0100-PAV	208/230	1	6.7	33.5	1.55	7.92	014-0061-18	014-0064-02	040-0166-14	RP	071-0329-00
RRL4-0100-CAV	208/230	1	7.3	40	1.65	6.3	014-0058-19	014-0064-02	040-0166-14	RP	071-0127-05
RRS4-0075-IAA	115	1	13.3	66.3	0.416	3.15	014-0058-09		040-0168-03	RC	071-0127-18
RRS4-0075-IAV	208/230	1	6.5	33.5	1.55	7.92	014-0061-18		040-0168-01	RC	071-0329-07
RRT62C1E-IAA	115	1	9.5	44	0.6	4.3	014-0053-18		040-0150-11	RC	071-0561-61
RRT62C1E-IAB	230	1	4.5	21	2.7	12.7	014-0036-24		040-0150-04	RC	071-0647-11
RRT64C1E-CAA	115	1	11	45	0.51	2.62	014-0058-43	014-0037-17	040-0166-03	RP	071-0561-60
RRT64C1E-IAA	115	1	11	45	0.51	2.62	014-0058-43		040-0172-04	RC	071-0647-04
RRT73C1E-CAA	115	1	11	54.5	0.43	2.66	014-0058-36	014-0064-13	040-0166-21	RP	071-0644-01
RRT73C1E-IAA	115	1	11	54.5	0.43	2.66	014-0058-36		040-0172-03	RC	071-0605-01
RS40C1E-IAA	115	1	9	51	0.687	4.07	014-0058-22		040-0168-00	RC	071-0127-41
RS40C1E-IAV	208/230	1	4.9	24.1	2.1	18.3	014-0058-17		040-0168-02	RC	071-0329-11
RS40C2-IAA	115	1	10.1	51	0.687	4.07	014-0058-22		040-0168-00	RC	071-0127-41
RS40C2-IAV	208/230	1	5.6	24.1	2.1	18.3	014-0058-17		040-0168-02	RC	071-0329-11
RS40C2E-IAA	115	1	10.1	51	0.687	4.07	014-0058-22		040-0168-00	RC	071-0127-41
RS40C2E-IAV	208/230	1	5.6	24.1	2.1	18.3	014-0058-17		040-0168-02	RC	071-0329-11
RS43C1E-CAA	115	1	10.1	51	0.59	4.08	014-0058-11	014-0064-02	040-0166-21	RP	071-0329-15

† ‡ § \* See Section F Introduction for more information.  
FB16

### Electrical Data - Welded Compressors

Model	Volts	PH	Max RLA	LRA	Resistance		Start Cap P/N ‡	Run Cap P/N ‡	Relay P/N §	Part Type*	Protector P/N
					Run	Start or Line/Line †					
RS43C1E-CAV	208/230	1	5.4	24.1	2.1	18.3	014-0058-17	014-0064-00	040-0166-14	RP	071-0329-10
RS43C1E-IAA	115	1	10.1	51	0.59	4.08	014-0058-11		040-0168-00	RC	071-0329-15
RS43C1E-IAV	208/230	1	5.7	24.1	2.1	18.3	014-0058-17		040-0168-02	RC	071-0329-11
RS43C2-CAA	115	1	10.1	51	0.59	4.08	014-0058-11	014-0064-02	040-0166-21	RP	071-0329-15
RS43C2E-CAA	115	1	10.1	51	0.59	4.08	014-0058-11	014-0064-02	040-0166-21	RP	071-0329-15
RS43C2E-CAV	208/230	1	5.4	24.1	2.1	18.3	014-0058-17	014-0064-00	040-0166-14	RP	071-0329-10
RS43C2E-IAA	115	1	10.1	51	0.59	4.08	014-0058-11		040-0168-00	RC	071-0329-15
RS43C2E-IAV	208/230	1	5.7	24.1	2.1	18.3	014-0058-17		040-0168-02	RC	071-0329-11
RS43CAE-CAA	115	1	10.1	51	0.59	4.08	014-0058-11	014-0064-02	040-0166-21	RP	071-0329-15
RS47C2-IAA	115	1	14.3	66.3	0.416	3.15	014-0058-27		040-0168-03	RC	071-0127-30
RS47C2-IAV	208/230	1	7.1	35.5	1.55	7.92	014-0058-19		040-0168-01	RC	071-0370-29
RS54C1E-IAA	115	1	11.8	66.3	0.455	2.245	014-0058-27		040-0168-03	RC	071-0127-06
RS54C1E-IAV	208/230	1	6.8	33.5	1.55	7.92	014-0058-18		040-0168-01	RC	071-0329-04
RS54C2-IAA	115	1	11.8	66.3	0.455	2.245	014-0058-27		040-0168-03	RC	071-0127-06
RS54C2-IAV	208/230	1	6.8	33.5	1.55	7.92	014-0058-18		040-0168-01	RC	071-0329-04
RS54C2E-IAA	115	1	11.8	66.3	0.455	2.245	014-0058-27		040-0168-03	RC	071-0127-06
RS54C2E-IAV	208/230	1	6.8	33.5	1.55	7.92	014-0058-18		040-0168-01	RC	071-0329-04
RS55C1E-CAV	208/230	1	6.7	33.5	1.55	7.92	014-0061-18	014-0064-02	040-0166-14	RP	071-0329-30
RS55C1E-PAA	115	1	13.2	60	0.551	4.8	014-0058-06	014-0064-05	040-0166-19	RP	071-0127-40
RS55C1E-PAV	208/230	1	6.7	33.5	1.55	7.92	014-0061-18	014-0064-02	040-0166-14	RP	071-0329-30
RS55C2-CAA	115	1	13.2	60	0.66	4.2	014-0058-00	014-0064-05	040-0166-19	RP	071-0518-02
RS55C2-CAV	208/230	1	6.1	40	3.09	3.82	014-0058-04	014-0064-05	040-0166-14	RP	071-0527-08
RS55C2E-CAA	115	1	13.2	60	0.66	4.2	014-0058-00	014-0064-05	040-0166-19	RP	071-0518-02
RS55C2E-CAV	208/230	1	6.1	40	3.09	3.82	014-0058-04	014-0064-05	040-0166-14	RP	071-0527-08
RS64C1E-CAA	115	1	15.1	59	0.573	5.68	014-0058-25	014-0064-12	040-0166-02	RP	071-0127-43
RS64C1E-CAV	208/230	1	7.7	37	1.55	7.92	014-0058-14	014-0064-02	040-0166-14	RP	071-0329-16

† ‡ § \* See Section F Introduction for more information.

FB17

### Electrical Data - Welded Compressors

Model	Volts	PH	Max RLA	LRA	Resistance		Start Cap P/N ‡	Run Cap P/N ‡	Relay P/N §	Part Type*	Protector P/N
					Run	Start or Line/Line †					
RS64C1E-IAV	208/230	1	9.2	45	1.56	7.45	014-0058-19		040-0168-00	RC	071-0127-37
RS64C1E-PAA	115	1	15.1	59	0.573	5.68	014-0058-25	014-0064-12	040-0166-02	RP	071-0127-43
RS64C1E-PFA	115	1	15.1	59	0.573	5.68	014-0058-25	014-0064-12	040-0166-02	RP	071-0546-13
RS64C2-CAA	115	1	13.2	59	0.573	5.68	014-0058-25	014-0064-12	040-0166-02	RP	071-0127-43
RS64C2-CAV	208/230	1	7.7	37	1.55	7.92	014-0058-14	014-0064-02	040-0166-14	RP	071-0329-16
RS64C2-IAV	208/230	1	9.2	45	1.56	7.45	014-0058-19		040-0168-00	RC	071-0127-37
RS64C2-PAA	115	1	13.2	59	0.573	5.68	014-0058-25	014-0064-12	040-0166-02	RP	071-0127-43
RS64C2E-CAA	115	1	15.1	59	0.573	5.68	014-0058-25	014-0064-12	040-0166-02	RP	071-0127-43
RS64C2E-CAV	208/230	1	7.7	37	1.55	7.92	014-0058-14	014-0064-02	040-0166-14	RP	071-0329-16
RS64C2E-IAV	208/230	1	9.2	45	1.56	7.45	014-0058-19		040-0168-00	RC	071-0127-37
RS64C2E-PAA	115	1	15.1	59	0.573	5.68	014-0058-25	014-0064-12	040-0166-02	RP	071-0127-43
RS70C1-PAA	115	1	16.7	72.5	0.409	5.39	014-0058-18	014-0064-06	040-0166-19	RP	071-0127-18
RS70C1-PFJ	265	1	6	30	3.42	5.1	014-0036-17	014-0064-05	040-0166-19	RP	071-0432-11
RS70C1-PFV	208/230	1	7	34.2	1.96	4.89	014-0058-19	014-0064-05	040-0166-19	RP	071-0432-09
RS70C1-TFC	208/230	3	4.7	31	0	3.72					071-0481-00
RS70C1-TFD	460	3	2.6	15	0	14.3					071-0481-02
RS70C1E-PFJ	265	1	6	30	3.42	5.1	014-0036-17	014-0064-05	040-0166-19	RP	071-0432-11
RS70C1E-PFV	208/230	1	7	34.2	1.96	4.89	014-0058-19	014-0064-05	040-0166-19	RP	071-0432-09
RS70C1E-TFC	208/230	3	4.7	31	0	3.72					071-0481-00
RS70C1E-TFD	460	3	2.6	15	0	14.3					071-0481-02
RS73C1E-PFJ	265	1	8.2	39.6	1.97	5.37	014-0036-17	014-0064-12	040-0166-14	RP	071-0512-12
RS80C1E-CAA	115	1	18.6	72.5	0.409	5.39	014-0058-31	014-0064-05	040-0166-19	RP	071-0127-46
RS80C1E-CAV	208/230	1	9.6	46	1.36	4.45	014-0058-00	014-0064-10	040-0166-14	RP	071-0127-37
RS80C1E-TF5	200/230	3	6.4	41	0	2.4					071-0481-01
RS80C1E-TFD	460	3	2.5	15	0	14.3					071-0481-02
RS80C2-CAA	115	1	18.6	72.5	0.409	5.39	014-0058-31	014-0064-05	040-0166-19	RP	071-0127-46

† ‡ § \* See Section F Introduction for more information.  
FB18

### Electrical Data - Welded Compressors

Model	Volts	PH	Max RLA	LRA	Resistance		Start Cap P/N ‡	Run Cap P/N ‡	Relay P/N §	Part Type*	Protector P/N
					Run	Start or Line/Line †					
RS80C2-CAV	208/230	1	9.6	46	1.36	4.45	014-0058-00	014-0064-10	040-0166-14	RP	071-0127-37
RS80C2-TF5	200/230	3	6.4	41	0	2.4					071-0481-01
RS80C2-TFD	460	3	2.5	15	0	14.3					071-0481-02
RS80C2E-CAA	115	1	18.6	72.5	0.409	5.39	014-0058-31	014-0064-05	040-0166-19	RP	071-0127-46
RS80C2E-CAV	208/230	1	9.6	46	1.36	4.45	014-0058-00	014-0064-10	040-0166-14	RP	071-0127-37
RS80C2E-TF5	200/230	3	6.4	41	0	2.4					071-0481-01
RS80C2E-TFD	460	3	2.5	15	0	14.3					071-0481-02
RS86C1E-PFJ	265	1	8.9	36.1	2.44	4.77	014-0036-16	014-0064-11	040-0166-15	RP	071-0432-16
RS86C1E-PFV	208/230	1	9.8	43.3	1.41	2.65	014-0058-25	014-0064-06	040-0166-19	RP	071-0421-21
RS86C2E-PFV	208/230	1	9.8	43.3	1.41	2.65	014-0058-25	014-0064-06	040-0166-19	RP	071-0546-01
RS97C1E-CAA	115	1	20.7	95	0.324	4.142	014-0061-04	014-0064-07	040-0166-18	RP	071-0127-45
RS97C1E-CAV	208/230	1	11	51	1.12	4.92	014-0036-17	014-0064-11	040-0166-14	RP	071-0127-24
RS97C1E-TFC	208/230	3	7	35	0	2.58					071-0404-01
RS97C2-CAA	115	1	20.7	95	0.324	4.142	014-0061-04	014-0064-07	040-0166-18	RP	071-0127-45
RS97C2-CAV	208/230	1	10.4	51	1.12	4.92	014-0036-17	014-0064-11	040-0166-14	RP	071-0127-24
RS97C2-TFC	208/230	3	7	35	0	2.58					071-0404-01
RS97C2E-CAA	115	1	20.7	95	0.324	4.142	014-0061-04	014-0064-07	040-0166-18	RP	071-0127-45
RS97C2E-CAV	208/230	1	11	51	1.12	4.92	014-0036-17	014-0064-11	040-0166-14	RP	071-0127-24
RS97C2E-TFC	208/230	3	7	35	0	2.58					071-0404-01
RSE4-0075-IAA	115	1	14.3	66.3	0.416	3.15	014-0058-27		040-0168-03	RC	071-0127-30
RSE4-0075-IAV	208/230	1	7.1	35.5	1.55	7.92	014-0058-19		040-0168-01	RC	071-0370-29
RSE4-0076-IAA	115	1	14.3	66.3	0.416	3.15	014-0058-27		040-0168-03	RC	071-0127-30
RSE4-0076-IAV	208/230	1	7.1	35.5	1.55	7.92	014-0058-19		040-0168-01	RC	071-0370-29
RSF5-0075-CAA	115	1	13.5	72.7	0.416	3.15	014-0058-27	014-0064-17	040-0166-21	RP	071-0506-00
RSL2-0075-IAA	115	1	11.8	66.3	0.455	2.245	014-0058-27		040-0168-03	RC	071-0127-06
RSL2-0075-IAV	208/230	1	6.8	33.5	1.55	7.92	014-0061-18		040-0168-01	RC	071-0329-04

† ‡ § \* See Section F Introduction for more information.

FB19

### Electrical Data - Welded Compressors

Model	Volts	PH	Max RLA	LRA	Resistance		Start Cap P/N ‡	Run Cap P/N ‡	Relay P/N §	Part Type*	Protector P/N
					Run	Start or Line/Line †					
RSL2-0100-CAA	115	1	18	78	0.412	4.83	014-0058-26	014-0064-06	040-0166-14	RP	071-0127-30
RSL2-0100-CAV	208/230	1	10.4	51	1.12	4.92	014-0036-17	014-0064-11	040-0166-14	RP	071-0127-24
RSL2-0101-CAA	115	1	18	78	0.412	4.83	014-0058-26	014-0064-06	040-0166-14	RP	071-0127-30
RSL2-0101-CAV	208/230	1	10.4	51	1.12	4.92	014-0036-17	014-0064-11	040-0166-14	RP	071-0127-24
RSL5-0100-CAV	208/230	1	9.4	51	1.12	4.92	014-0036-17	014-0064-11	040-0166-14	RP	071-0127-24
RSL5-0100-TFC	208/230	3	5.7	35	0	2.58					071-0404-01
RSL5-0101-CAV	208/230	1	9.4	51	1.12	4.92	014-0036-17	014-0064-11	040-0166-14	RP	071-0127-24
RSL5-0101-TFC	208/230	3	5.7	35	0	2.58					071-0404-01
RSN4-0050-IAA	115	1	9	51	0.687	4.07	014-0058-22		040-0168-00	RC	071-0127-34
RSN4-0050-IAV	208/230	1	4.9	24.1	2.1	18.3	014-0058-17		040-0168-02	RC	071-0329-11
RSN4-0075-CAV	208/230	1	7.7	37	1.55	7.92	014-0058-14	014-0064-02	040-0166-14	RP	071-0329-16
RSN4-0075-IAA	115	1	14.9	66.3	0.416	3.15	014-0058-27		040-0168-03	RC	071-0127-30
RSN4-0075-IAV	208/230	1	8.8	45	1.56	7.45	014-0058-14		040-0168-04	RC	071-0127-05
RSN4-0075-PAA	115	1	10.3	50	0.585	5.07	014-0058-06	014-0064-05	040-0166-19	RP	071-0127-19
RSN4-0100-CAV	208/230	1	7.7	37	1.55	7.92	014-0058-14	014-0064-02	040-0166-14	RP	071-0329-16
RSN4-0100-PAA	115	1	10.3	50	0.585	5.07	014-0058-06	014-0064-05	040-0166-19	RP	071-0127-19
RSN6-0075-CAA	115	1	12.1	75	0.483	5.54	014-0061-04	014-0064-02	040-0166-15	RP	071-0127-42
RSN6-0075-IAA	115	1	14.3	66.3	0.416	3.15	014-0058-27		040-0168-03	RC	071-0127-30
RSN6-0075-IAV	208/230	1	6.9	45	1.56	7.45	014-0058-14		040-0168-04	RC	071-0127-05
RST40C1E-CAA	115	1	9	50	0.51	2.62	014-0036-24	014-0064-13	040-0166-03	RP	071-0561-48
RST40C1E-CAB	230	1	5.3	25	2.7	12.7	014-0036-24	014-0064-13	040-0166-26	RP	071-0561-57
RST40C1E-CAV	208/230	1	5.1	27	1.91	6.38	014-0058-31	014-0064-33	040-0166-18	RP	071-0561-23
RST40C1E-IAA	115	1	9	50	0.51	2.62	014-0059-20		040-0150-37	RC	071-0561-56
RST40C1E-IAB	230	1	5.3	25	2.7	12.7	014-0059-09		040-0150-14	RC	071-0561-12
RST40C1E-IAV	208/230	1	5.1	27	1.91	6.38	014-0053-30		040-0150-31	RC	071-0561-65
RST45C1E-CAA	115	1	10.5	54.5	0.43	2.66	014-0036-24	014-0064-13	040-0166-21	RP	071-0604-10

† ‡ § \* See Section F Introduction for more information.  
FB20

### Electrical Data - Welded Compressors

Model	Volts	PH	Max RLA	LRA	Resistance		Start Cap P/N ‡	Run Cap P/N ‡	Relay P/N §	Part Type*	Protector P/N
					Run	Start or Line/Line †					
RST45C1E-CAV	208/230	1	5.1	26.5	1.69	6.49	014-0058-25	014-0064-09	040-0166-27	RP	071-0561-28
RST45C1E-IAA	115	1	10.5	54.5	0.43	2.66	014-0058-36		040-0172-03	RC	071-0605-09
RST45C1E-IAV	208/230	1	5.1	26.5	1.69	6.49	014-0059-09		040-0150-36	RC	071-0561-16
RST55C1E-CAA	115	1	15	70	0.4	2.6	014-0058-36	014-0064-13	040-0166-21	RP	071-0605-05
RST55C1E-CAB	230	1	7	37	1.75	10.1	014-0036-18	014-0064-33	040-0166-26	RP	071-0647-02
RST55C1E-IAA	115	1	15	70	0.4	2.6	014-0058-41		040-0172-03	RC	071-0605-08
RST55C1E-IAB	230	1	7	37	1.75	10.1	014-0059-18		040-0150-35	RC	071-0561-55
RST64C1E-CAV	208/230	1	8.9	43	1.18	5.94	014-0058-25	014-0064-10	040-0166-30	RP	071-0604-13
RST64C1E-CFA	115	1	14.6	77	0.36	2.39	014-0058-43	014-0064-14	040-0166-37	RP	
RST64C1E-IAV	208/230	1	8.9	43	1.18	5.94	014-0058-31		040-0172-05	RC	071-0604-14
RSU4-0050-CAA	115	1	9.6	51	0.59	4.08	014-0058-27	014-0064-02	040-0166-11	RP	071-0329-15
RSU4-0050-IAA	115	1	9.6	51	0.59	4.08	014-0061-15		040-0168-03	RC	071-0329-15
RSU5-0050-IAA	115	1	9.6	51	0.59	4.08	014-0061-15		040-0168-03	RC	071-0329-15
RSU5-0050-IAV	208/230	1	5.4	24.1	2.1	18.3	014-0058-17		040-0168-02	RC	071-0329-11

† ‡ § \* See Section F Introduction for more information.

FB21



### Electrical Data - Copelametic - Air Cooled

Model	Volts	PH	Max RLA	LRA	Resistance		Start Cap P/N †	Run Cap P/N ‡	Relay P/N §	Part Type*	Protector P/N
					Run or Line to WYE	Start or Line to Line†					
3AB1-0300-TAE	575	3	4.4	30	2.7	5.4					071-0090-16
3AB1-0310-TAC	208/230	3	8.2	82	0.47	0.9					071-0090-01
3AB1-0310-TAD	460	3	5.5	41	1.9	3.6					071-0090-03
3AB1-0311-TAC	208/230	3	10	82	0.42	0.837					071-0090-37
3AB1-0311-TAD	460	3	5.1	41	1.653	3.309					071-0090-03
3AB1-031A-TAC	208/230	3	10	82	0.42	0.837					071-0090-37
3AB1-031A-TAD	460	3	5.1	41	1.653	3.309					071-0090-03
3AB2-0310-CAB	230	1	14.7	86	0.61	2.54	014-0006-13	014-0064-12	040-0166-28	RP	071-0119-01
3AB2-031A-CAB	230	1	14.7	86	0.61	2.54	014-0006-13	014-0064-12	040-0166-28	RP	071-0119-01
3ABA-031E-TAC	208/230	3	10	82	0.42	0.837					071-0090-37
3ABA-031E-TAD	460	3	5.1	41	1.653	3.309					071-0090-03
3ABA-031L-TAC	208/230	3	10	82	0.42	0.837					071-0090-37
3ABB-032E-CAB	230	1	14.7	86	0.595	2.41	014-0006-13	014-0064-14	040-0166-28	RP	071-0119-02
3ABB-032L-CAB	230	1	14.7	86	0.595	2.41	014-0006-13	014-0064-14	040-0166-28	RP	071-0119-02
3AH1-0200-TAC	208/230	3	6.6	46	0.84	1.675					071-0090-00
3AH1-0200-TAD	460	3	3.7	23	3.1	6					071-0090-08
3AH1-0200-TAE	575	3	2.3	20	4.905	9.3					071-0090-15
3AH1-020A-TAC	208/230	3	6.6	46	0.84	1.675					071-0090-00
3AH1-020A-TAD	460	3	3.7	23	3.1	6					071-0090-08
3AH2-0200-CAB	230	1	9.3	58	1.125	2.7	014-0036-22	014-0064-11	040-0166-20	RP	071-0092-18
3AH2-0200-CAH	208	1	12.4	57.2	0.74	2.836	014-0036-22	014-0064-11	040-0166-20	RP	071-0089-00
3AH2-020A-CAB	230	1	9.3	58	1.125	2.7	014-0036-22	014-0064-11	040-0166-20	RP	071-0092-18
3AH2-020A-CAH	208	1	12.4	57.2	0.74	2.836	014-0036-22	014-0064-11	040-0166-20	RP	071-0089-00

† ‡ § \* See Section F Introduction for more information.

FC1

### Electrical Data - Copelametic - Air Cooled

Model	Volts	PH	Max RLA	LRA	Resistance		Start Cap P/N †	Run Cap P/N ‡	Relay P/N §	Part Type*	Protector P/N
					Run or Line to WYE	Start or Line to Line†					
3AJ1-0200-TAC	208/230	3	5.6	46	0.84	1.675					071-0090-00
3AJ1-0200-TAD	460	3	3	23	3.1	6					071-0090-08
3AJ1-0200-TAE	575	3	2.3	20	4.905	9.3					071-0090-15
3AJ1-020A-TAC	208/230	3	5.6	46	0.84	1.675					071-0090-00
3AJ1-020A-TAD	460	3	3	23	3.1	6					071-0090-08
3AJ2-0200-CAB	230	1	9.5	58	1.125	2.7	014-0036-22	014-0064-11	040-0166-20	RP	071-0092-18
3AJ2-0200-CAH	208	1	12.4	57.2	0.74	2.836	014-0036-22	014-0064-11	040-0166-20	RP	071-0092-18
3AJ2-020A-CAB	230	1	9.5	58	1.125	2.7	014-0036-22	014-0064-11	040-0166-20	RP	071-0092-18
3AJ2-0310-CAB	230	1	12.6	86	0.61	2.54	014-0006-13	014-0064-12	040-0166-28	RP	071-0119-01
3AJA-0210-TAC	208/230	3	9.2	82	0.444	0.944					071-0090-44
3AJA-021A-TAC	208/230	3	9.2	82	0.444	0.944					071-0090-44
3AJA-021L-TAC	208/230	3	9.2	82	0.444	0.944					071-0090-44
3AJB-0210-CAB	230	1	14.4	86	0.595	2.41	014-0006-13	014-0064-12	040-0166-28	RP	071-0119-05
3AJB-021A-CAB	230	1	14.4	86	0.595	2.41	014-0006-13	014-0064-12	040-0166-28	RP	071-0119-05
3WB1-0300-TAE	575	3	4.4	30	2.7	5.4					071-0090-16
3WB1-0310-TAC	208/230	3	8.2	82	0.47	0.9					071-0090-01
3WB1-0310-TAD	460	3	5.5	41	1.9	3.6					071-0090-03
3WB1-0311-TAC	208/230	3	10	82	0.42	0.837					071-0090-37
3WB1-031A-TAC	208/230	3	10	82	0.42	0.837					071-0090-37
3WB2-0310-CAB	230	1	14.7	86	0.61	2.54	014-0006-13	014-0064-12	040-0166-28	RP	071-0119-01
3WH1-0200-TAC	208/230	3	6.6	46	0.84	1.675					071-0090-00
3WH1-0200-TAD	460	3	3.7	23	3.1	6					071-0090-08
3WH1-0200-TAE	575	3	2.3	20	4.905	9.3					071-0090-15

† ‡ § \* See Section F Introduction for more information.

FC2

### Electrical Data - Copelametic - Air Cooled

Model	Volts	PH	Max RLA	LRA	Resistance		Start Cap P/N †	Run Cap P/N ‡	Relay P/N §	Part Type*	Protector P/N
					Run or Line to WYE	Start or Line to Line†					
3WH1-020A-TAD	460	3	3.7	23	3.1	6					071-0090-08
3WH2-0200-CAB	230	1	9.3	58	1.125	2.7	014-0036-22	014-0064-11	040-0166-20	RP	071-0092-18
3WH2-0200-CAH	208	1	12.4	57.2	0.74	2.836	014-0036-22	014-0064-11	040-0166-20	RP	071-0089-00
3WJ1-0200-TAC	208/230	3	5.6	46	0.84	1.675					071-0090-00
3WJ1-0200-TAD	460	3	3	23	3.1	6					071-0090-08
3WJ1-0200-TAE	575	3	2.3	20	4.905	9.3					071-0090-15
3WJ2-0200-CAB	230	1	9.5	58	1.125	2.7	014-0036-22	014-0064-11	040-0166-20	RP	071-0092-18
3WJ2-0200-CAH	208	1	12.4	57.2	0.74	2.836	014-0036-22	014-0064-11	040-0166-20	RP	071-0092-18
EAA1-0150-TAC	208/230	3	5.9	38	1.008	2.01					071-0090-03
EAA1-0150-TAE	575	3	2.2	14.3	6.2	12.4					071-0090-21
EAA1-015L-TAC	208/230	3	5.9	38	1.008	2.01					071-0090-03
EAA2-0150-CAB	230	1	8.9	41	1.703	4.363	014-0036-21	014-0064-10	040-0166-20	RP	071-0092-18
EAA2-0150-CAH	208	1	8.3	44	1.345	4.61	014-0036-21	014-0064-10	040-0166-30	RP	071-0092-18
EAA2-015A-CAH	208	1	8.3	44	1.345	4.61	014-0036-21	014-0064-10	040-0166-30	RP	071-0092-18
EAAB-015A-TAC	208/230	3	5.9	38	1.008	2.01					071-0090-03
EAB1-015A-CAB	230	1	8.9	41	1.703	4.363	014-0036-21	014-0064-10	040-0166-20	RP	071-0092-16
EAB1-015A-CAH	208	1	8.3	44	1.345	4.61	014-0036-21	014-0064-10	040-0166-30	RP	071-0092-18
EAB1-0150-TAC	208/230	3	5.8	38	1.008	2.01					071-0090-03
EAB1-0150-TAE	575	3	2.2	14.3	6.2	12.4					071-0090-21
EAB1-015A-TAC	208/230	3	5.8	38	1.008	2.01					071-0090-03
EAB2-0150-CAB	230	1	6.4	41	1.703	4.363	014-0036-21	014-0064-10	040-0166-20	RP	071-0092-16
EAB2-0150-CAH	208	1	5.6	44	1.345	4.61	014-0036-21	014-0064-10	040-0166-30	RP	071-0092-16
EAB2-015A-CAB	230	1	6.4	41	1.703	4.363	014-0036-21	014-0064-10	040-0166-20	RP	071-0092-16

† ‡ § \* See Section F Introduction for more information.

FC3

### Electrical Data - Copelametic - Air Cooled

Model	Volts	PH	Max RLA	LRA	Resistance		Start Cap P/N †	Run Cap P/N ‡	Relay P/N §	Part Type*	Protector P/N
					Run or Line to WYE	Start or Line to Line†					
EABA-0200-TAC	208/230	3	6.8	46	0.84	1.675					071-0090-00
EABA-0200-TAD	460	3	3.6	23	3.346	6.692					071-0090-08
EABA-0200-TAE	575	3	2.3	20	4.905	9.3					071-0090-15
EABA-020A-TAC	208/230	3	6.8	46	0.84	1.675					071-0090-00
EABB-0200-CAB	230	1	8.4	58	1.125	2.7	014-0036-22	014-0064-11	040-0166-20	RP	071-0092-18
EABB-020A-CAB	230	1	8.4	58	1.125	2.7	014-0036-22	014-0064-11	040-0166-20	RP	071-0092-18
EAC1-0150-TAC	208/230	3	6	38	1.008	2.01					071-0090-03
EAC1-0150-TAE	575	3	2.2	14.3	6.2	12.4					071-0090-21
EAC2-0150-CAB	230	1	7.1	41	1.703	4.363	014-0036-21	014-0064-10	040-0166-20	RP	071-0092-16
EAC2-0150-CAH	208	1	6.4	44	1.345	4.61	014-0036-21	014-0064-10	040-0166-30	RP	071-0092-16
EAC2-015A-CAB	230	1	7.1	41	1.703	4.363	014-0036-21	014-0064-10	040-0166-20	RP	071-0092-16
EACA-0200-TAC	208/230	3	6.6	46	0.84	1.675					071-0090-00
EACA-0200-TAD	460	3	3.5	23	3.346	6.692					071-0090-08
EACA-0200-TAE	575	3	2.3	20	4.905	9.3					071-0090-15
EACA-020A-TAC	208/230	3	6.6	46	0.84	1.675					071-0090-00
EACA-020A-TAD	460	3	3.5	23	3.346	6.692					071-0090-08
EACB-0200-CAB	230	1	8.4	58	1.125	2.7	014-0036-22	014-0064-11	040-0166-20	RP	071-0092-18
EACB-0200-CAH	208	1	11.9	57.2	0.74	2.836	014-0036-22	014-0064-11	040-0166-20	RP	071-0092-18
EAD1-0200-TAC	208/230	3	NA	46	0.84	1.675					071-0090-00
EAD1-0200-TAD	460	3	NA	23	3.346	6.692					071-0090-08
EAD1-0200-TAE	575	3	NA	20	4.905	9.3					071-0090-15
EAD1-020L-TAC	208/230	3	6.8	46	0.84	1.675					071-0090-00
EAD1-0320-TAC	208/230	3	12.4	85	0.419	0.838					071-0090-38

† ‡ § \* See Section F Introduction for more information.

FC4

### Electrical Data - Copelametic - Air Cooled

Model	Volts	PH	Max RLA	LRA	Resistance		Start Cap P/N †	Run Cap P/N ‡	Relay P/N §	Part Type*	Protector P/N
					Run or Line to WYE	Start or Line to Line†					
EAD1-0320-TAD	460	3	5.2	42	1.641	3.282					071-0090-03
EAD1-032A-TAC	208/230	3	12.4	85	0.419	0.838					071-0090-38
EAD1-032A-TAD	460	3	5.2	42	1.641	3.282					071-0090-03
EAD1-032L-TAC	208/230	3	12.4	85	0.419	0.838					071-0090-38
EAD1-032L-TAD	460	3	5.2	42	1.641	3.282					071-0090-03
EAD2-0200-CAB	230	1	NA	58	1.125	2.7	014-0036-22	014-0064-11	040-0166-20	RP	071-0092-18
EAD2-0200-CAH	208	1	NA	57.2	0.74	2.836	014-0036-22	014-0064-11	040-0166-20	RP	071-0092-18
EAD2-020A-CAH	208	1	12.4	57.2	0.74	2.836	014-0036-22	014-0064-11	040-0166-20	RP	071-0092-18
EAD2-020L-CAB	230	1	8.4	58	1.125	2.7	014-0036-22	014-0064-11	040-0166-20	RP	071-0092-18
EAD2-0320-CAB	230	1	16	102	0.519	2.435	014-0006-13	014-0064-14	040-0166-28	RP	071-0119-06
EADA-0200-TAC	208/230	3	6.8	46	0.84	1.675					071-0090-00
EADA-0200-TAD	460	3	3.1	20.4	0	6.765					071-0090-15
EADA-020A-TAC	208/230	3	6.8	46	0.84	1.675					071-0090-00
EADA-020A-TAD	460	3	3.1	20.4	0	6.765					071-0090-15
EADA-020E-TAC	208/230	3	6.8	46	0.84	1.675					071-0090-00
EADA-020L-TAC	208/230	3	6.8	46	0.84	1.675					071-0090-00
EADB-0200-CAB	230	1	8.5	58	1.125	2.7	014-0036-22	014-0064-11	040-0166-20	RP	071-0092-18
EADB-020A-CAB	230	1	8.5	58	1.125	2.7	014-0036-22	014-0064-11	040-0166-20	RP	071-0092-18
EADB-021E-CAB	230	1	10	58	1.125	2.7	014-0036-22	014-0064-11	040-0166-20	RP	071-0099-03
EADB-021L-CAB	230	1	10	58	1.125	2.7	014-0036-22	014-0064-11	040-0166-20	RP	071-0099-03
EAJ1-0150-TAC	208/230	3	5.9	38	1.008	2.01					071-0090-03
EAJ1-0150-TAE	575	3	2.2	14.3	6.2	12.4					071-0090-21
EAJ2-0150-CAB	230	1	6.6	41	1.703	4.363	014-0036-21	014-0064-10	040-0166-20	RP	071-0092-16

† ‡ § \* See Section F Introduction for more information.

FC5

### Electrical Data - Copelametic - Air Cooled

Model	Volts	PH	Max RLA	LRA	Resistance		Start Cap P/N †	Run Cap P/N ‡	Relay P/N §	Part Type*	Protector P/N
					Run or Line to WYE	Start or Line to Line†					
EAJ2-0150-CAH	208	1	5.9	44	1.345	4.61	014-0036-21	014-0064-10	040-0166-30	RP	071-0092-16
EAJA-015A-TAC	208/230	3	5.9	38	1.008	2.01					071-0090-03
EAJB-015A-CAB	230	1	6.6	41	1.703	4.363	014-0036-21	014-0064-10	040-0166-20	RP	071-0092-16
EAJB-015A-CAH	208	1	5.9	44	1.345	4.61	014-0036-21	014-0064-10	040-0166-30	RP	071-0092-16
EAL1-0200-TAC	208/230	3	NA	46	0.84	1.675					071-0090-00
EAL1-0200-TAD	460	3	NA	23	3.346	6.692					071-0090-08
EAL1-0200-TAE	575	3	NA	20	4.905	9.3					071-0090-15
EAL1-020A-TAD	460	3	NA	23	3.346	6.692					071-0090-08
EAL2-0200-CAB	230	1	NA	58	1.125	2.7	014-0036-22	014-0064-11	040-0166-20	RP	071-0092-18
EAL2-0200-CAH	208	1	NA	57.2	0.74	2.836	014-0036-22	014-0064-11	040-0166-20	RP	071-0092-18
EALA-020A-TAC	208/230	3	7.1	46	0.84	1.675					071-0090-00
EALB-020A-CAB	230	1	8.7	58	1.125	2.7	014-0036-22	014-0064-11	040-0166-20	RP	071-0092-18
EALB-020A-CAH	208	1	12.9	57.2	0.74	2.836	014-0036-22	014-0064-11	040-0166-20	RP	071-0092-18
EAV1-0150-TAC	208/230	3	5.6	38	1.008	2.01					071-0090-03
EAV1-0150-TAE	575	3	2.2	14.3	6.2	12.4					071-0090-21
EAV1-015A-TAC	208/230	3	5.6	38	1.008	2.01					071-0090-03
EAV1-0200-TA7	380	3	NA	31.5	0	3.38					071-0090-03
EAV1-0200-TAC	208/230	3	NA	46	0.84	1.675					071-0090-00
EAV1-0200-TAD	460	3	NA	23	3.346	6.692					071-0090-08
EAV1-0200-TAE	575	3	NA	20	4.905	9.3					071-0090-15
EAV1-0200-TAU	200	3	NA	57.1	0	0.994					071-0090-17
EAV1-020L-TAC	208/230	3	6.6	46	0.84	1.675					071-0090-00
EAV1-020L-TAD	460	3	3.5	23	3.346	6.692					071-0090-08

† ‡ § \* See Section F Introduction for more information.

FC6

### Electrical Data - Copelametic - Air Cooled

Model	Volts	PH	Max RLA	LRA	Resistance		Start Cap P/N ‡	Run Cap P/N ‡	Relay P/N §	Part Type*	Protector P/N
					Run or Line to WYE	Start or Line to Line†					
EAV2-0150-CAB	230	1	6.4	41	1.703	4.363	014-0036-21	014-0064-10	040-0166-20	RP	071-0092-16
EAV2-0150-CAH	208	1	5.5	44	1.345	4.61	014-0036-21	014-0064-10	040-0166-30	RP	071-0092-16
EAV2-015A-CAB	230	1	6.4	41	1.703	4.363	014-0036-21	014-0064-10	040-0166-20	RP	071-0092-16
EAV2-0200-CAB	230	1	NA	58	1.125	2.7	014-0036-22	014-0064-11	040-0166-20	RP	071-0099-01
EAV2-0200-CAH	208	1	NA	57.2	0.74	2.836	014-0036-22	014-0064-11	040-0166-20	RP	071-0099-02
EAVA-0200-TAU	200	3	9.7	57.1	0	0.994					071-0090-17
EAVA-020E-TA7	380	3	4.7	31.5	0	3.38					071-0090-03
EAVA-020E-TAU	200	3	9.7	57.1	0	0.994					071-0090-17
EAVA-020L-TA7	380	3	4.7	31.5	0	3.38					071-0090-03
EAVA-020L-TAU	200	3	9.7	57.1	0	0.994					071-0090-17
EAVA-0210-TAC	208/230	3	7.4	50	0	1.2					071-0090-35
EAVA-0210-TAD	460	3	3.9	26.6	0	4.73					071-0090-13
EAVA-021A-TAC	208/230	3	7.4	50	0	1.2					071-0090-35
EAVA-021A-TAD	460	3	3.9	26.6	0	4.73					071-0090-13
EAVA-021E-TAC	208/230	3	7.4	50	0	1.2					071-0090-35
EAVA-021E-TAD	460	3	3.9	26.6	0	4.73					071-0090-13
EAVA-021E-TAE	575	3	3.1	20	4.905	9.3					071-0090-52
EAVA-021L-TAC	208/230	3	7.4	50	0	1.2					071-0090-35
EAVA-021L-TAD	460	3	3.9	26.6	0	4.73					071-0090-13
EAVB-015A-CAH	208	1	5.5	44	1.345	4.61	014-0036-21	014-0064-10	040-0166-30	RP	071-0092-16
EAVB-020A-CAB	230	1	9.6	58	1.125	2.7	014-0036-22	014-0064-11	040-0166-20	RP	071-0099-01
EAVB-020A-CAH	208	1	12.4	57.2	0.74	2.836	014-0036-22	014-0064-11	040-0166-20	RP	071-0099-02
EAVB-0210-CAV	208/230	1	14.7	102	0.519	2.435	014-0006-13	014-0064-14	040-0166-28	RP	071-0119-05

† ‡ § \* See Section F Introduction for more information.

FC7

### Electrical Data - Copelametic - Air Cooled

Model	Volts	PH	Max RLA	LRA	Resistance		Start Cap P/N ‡	Run Cap P/N ‡	Relay P/N §	Part Type*	Protector P/N
					Run or Line to WYE	Start or Line to Line†					
EAVB-021A-CAV	208/230	1	14.7	102	0.519	2.435	014-0006-13	014-0064-14	040-0166-28	RP	071-0119-05
EAVB-021E-CAV	208/230	1	14.7	102	0.519	2.435	014-0006-13	014-0064-14	040-0166-28	RP	071-0119-05
EAVB-021L-CAV	208/230	1	14.7	102	0.519	2.435	014-0006-13	014-0064-14	040-0166-28	RP	071-0119-05
EWA1-0150-TAC	208/230	3	5.9	38	1.008	2.01					071-0090-03
EWA1-0150-TAE	575	3	2.2	14.3	6.2	12.4					071-0090-21
EWA2-0150-CAB	230	1	8.9	41	1.703	4.363	014-0036-21	014-0064-10	040-0166-20	RP	071-0092-18
EWA2-0150-CAH	208	1	8.3	44	1.345	4.61	014-0036-21	014-0064-10	040-0166-30	RP	071-0092-18
EWB1-0150-TAC	208/230	3	5.8	38	1.008	2.01					071-0090-03
EWB2-0150-CAB	230	1	6.4	41	1.703	4.363	014-0036-21	014-0064-10	040-0166-20	RP	071-0092-16
EWBA-0200-TAC	208/230	3	6.8	46	0.84	1.675					071-0090-00
EWBA-0200-TAD	460	3	3.6	23	3.346	6.692					071-0090-08
EWBA-0200-TAE	575	3	2.3	20	4.905	9.3					071-0090-15
EWBB-0200-CAB	230	1	8.4	58	1.125	2.7	014-0036-22	014-0064-11	040-0166-20	RP	071-0092-18
EWCA-0200-TAC	208/230	3	6	38	1.008	2.01					071-0090-03
EWCA-0200-TAD	208/230	3	6.6	46	0.84	1.675					071-0090-00
EWCA-0200-TAE	460	3	3.5	23	3.346	6.692					071-0090-08
EWCA-0200-TAE	575	3	2.3	20	4.905	9.3					071-0090-15
EWCA-020A-TAC	208/230	3	6.6	46	0.84	1.675					071-0090-00
EWCA-020A-TAD	460	3	3.5	23	3.346	6.692					071-0090-08
EWCB-0200-CAB	230	1	8.4	58	1.125	2.7	014-0036-22	014-0064-11	040-0166-20	RP	071-0092-18
EWCB-0200-CAH	208	1	11.9	57.2	0.74	2.836	014-0036-22	014-0064-11	040-0166-20	RP	071-0092-18
EWD1-0200-TAC	208/230	3	NA	46	0.84	1.675					071-0090-00
EWD1-0200-TAD	460	3	3.4	23	3.346	6.692					071-0090-08

† ‡ § \* See Section F Introduction for more information.

FC8



### Electrical Data - Copelametic - Air Cooled

Model	Volts	PH	Max RLA	LRA	Resistance		Start Cap P/N †	Run Cap P/N ‡	Relay P/N §	Part Type*	Protector P/N
					Run or Line to WYE	Start or Line to Line†					
EWDA-020A-TAC	208/230	3	6.8	46	0.84	1.675					071-0090-00
EWJ1-0150-TAC	208/230	3	5.9	38	1.008	2.01					071-0090-03
EWJ1-0150-TAE	575	3	2.2	14.3	6.2	12.4					071-0090-21
EWJ2-0150-CAB	230	1	6.6	41	1.703	4.363	014-0036-21	014-0064-10	040-0166-20	RP	071-0092-16
EWJ2-0150-CAH	208	1	5.9	44	1.345	4.61	014-0036-21	014-0064-10	040-0166-30	RP	071-0092-16
EWL1-0200-TAC	208/230	3	7.1	46	0.84	1.675					071-0090-00
EWL1-0200-TAD	460	3	3.7	23	3.346	6.692					071-0090-08
EWL1-0200-TAE	575	3	2.3	20	4.905	9.3					071-0090-15
EWL1-020A-TAC	208/230	3	7.1	46	0.84	1.675					071-0090-00
EWL2-0200-CAB	230	1	8.7	58	1.125	2.7	014-0036-22	014-0064-11	040-0166-20	RP	071-0092-18
EWL2-0200-CAH	208	1	12.9	57.2	0.74	2.836	014-0036-22	014-0064-11	040-0166-20	RP	071-0092-18
EWV1-0150-TAC	208/230	3	5.6	38	1.008	2.01					071-0090-03
EWV1-0200-TAC	208/230	3	6.6	46	0.84	1.675					071-0090-00
EWV1-0200-TAD	460	3	3.5	23	3.346	6.692					071-0090-08
EWV1-0200-TAE	575	3	2.3	20	4.905	9.3					071-0090-15
EWV1-020A-TAC	208/230	3	6.6	46	0.84	1.675					071-0090-00
EWV1-020A-TAD	460	3	3.5	23	3.346	6.692					071-0090-08
EWV2-0150-CAB	230	1	6.4	41	1.703	4.363	014-0036-21	014-0064-10	040-0166-20	RP	071-0092-16
EWV2-0150-CAH	208	1	5.5	44	1.345	4.61	014-0036-21	014-0064-10	040-0166-30	RP	071-0092-16
EWV2-0200-CAB	230	1	9.6	58	1.125	2.7	014-0036-22	014-0064-11	040-0166-20	RP	071-0099-01
EWV2-0200-CAH	208	1	12.4	57.2	0.74	2.836	014-0036-22	014-0064-11	040-0166-20	RP	071-0099-02
EWVA-021E-TAC	208/230	3	7.4	50	0	1.2					071-0090-35
EWVA-021E-TAD	460	3	3.9	26.6	0	4.73					071-0090-13

† ‡ § \* See Section F Introduction for more information.

FC9

### Electrical Data - Copelametic - Air Cooled

Model	Volts	PH	Max RLA	LRA	Resistance		Start Cap P/N †	Run Cap P/N ‡	Relay P/N §	Part Type*	Protector P/N
					Run or Line to WYE	Start or Line to Line†					
EWVB-021E-CAV	208/230	1	14.7	102	0.519	2.435	014-0061-13	014-0064-14	040-0166-28	RP	071-0119-05
HAF2-0025-IAA	115	1	3.9	23	1.76	4.48	014-0061-06		040-0115-00	RC	071-0092-37
HAF2-0025-IAB	230	1	2.3	12.2	6.76	17.87	014-0061-13		040-0115-01	RC	071-0092-32
HAF2-0025-SAA	115	1	3.9	22.5	1.82	17.24			040-0115-00	RC	071-0092-37
HAF2-0033-IAA	115	1	5.4	31	1.23	3.1	014-0061-07		040-0166-08	RP	071-0092-04
HAF2-0033-IAB	230	1	2.5	12	5.07	12.505	014-0061-12		040-0166-19	RP	071-0092-31
HAFB-0033-IAA	115	1	5.4	31	1.23	3.1	014-0061-07		040-0166-08	RP	071-0092-04
HAFB-0034-IAA	115	1	5.9	43.5	0.875	2.39	014-0061-07		040-0166-08	RP	071-0092-35
HAFB-003E-IAA	115	1	5.4	31	1.23	3.1	014-0061-07		040-0166-08	RP	071-0092-04
HAFB-003L-IAA	115	1	5.4	31	1.23	3.1	014-0061-07		040-0166-08	RP	071-0092-04
HAG1-0050-TAC	208/230	3	2.4	13	3.62	7.24					071-0090-42
HAG1-005L-TAC	208/230	3	2.4	13	3.62	7.24					071-0090-42
HAG2-0050-CAA	115	1	8.6	44	0.755	2.36	014-0061-02	014-0064-00	040-0166-33	RP	071-0099-03
HAG2-0050-CAV	208/230	1	4	22	3	9.455	014-0036-21	014-0064-00	040-0166-09	RP	071-0092-27
HAG2-005L-CAV	208/230	1	4	22	3	9.455	014-0036-21	014-0064-00	040-0166-09	RP	071-0092-27
HAGA-005E-TAC	208/230	3	2.4	13	3.62	7.24					071-0090-42
HAGA-005L-TAC	208/230	3	2.4	13	3.62	7.24					071-0090-42
HAGB-005E-CAV	208/230	1	4	22	3	9.455	014-0036-21	014-0064-00	040-0166-09	RP	071-0092-27
HAGB-005L-CAV	208/230	1	4	22	3	9.455	014-0036-21	014-0064-00	040-0166-09	RP	071-0092-27
HAJ1-0050-TAC	208/230	3	2.2	13	3.62	7.24					071-0090-42
HAJ1-005L-TAC	208/230	3	2.2	13	3.62	7.24					071-0090-42
HAJ2-0025-IAA	115	1	4.1	23	1.76	4.48	014-0061-06		040-0115-00	RC	071-0092-37
HAJ2-0025-IAB	230	1	2.1	12.2	6.76	17.87	014-0061-13		040-0115-01	RC	071-0092-32

† ‡ § \* See Section F Introduction for more information.

FC10

### Electrical Data - Copelametic - Air Cooled

Model	Volts	PH	Max RLA	LRA	Resistance		Start Cap P/N ‡	Run Cap P/N ‡	Relay P/N §	Part Type*	Protector P/N
					Run or Line to WYE	Start or Line to Line†					
HAI2-0025-SAA	115	1	4.1	22.5	1.82	17.24			040-0115-00	RC	071-0092-37
HAI2-0033-IAA	115	1	5.2	31	1.23	3.1	014-0061-07		040-0166-08	RP	071-0092-04
HAI2-0033-IAB	230	1	2.5	12	5.07	12.505	014-0061-12		040-0166-19	RP	071-0092-31
HAI2-0050-CAA	115	1	8.5	44	0.755	2.36	014-0061-02	014-0064-00	040-0166-33	RP	071-0099-03
HAI2-0050-CAV	208/230	1	3.7	22	3	9.455	014-0036-21	014-0064-00	040-0166-09	RP	071-0092-27
HAI2-0050-IAA	115	1	7.1	43.5	0.875	2.39	014-0061-02		040-0166-08	RP	071-0092-35
HAI2-005L-CAV	208/230	1	3.7	22	3	9.455	014-0036-21	014-0064-00	040-0166-09	RP	071-0092-27
HAJA-005E-TAC	208/230	3	2.2	13	3.62	7.24					071-0090-42
HAJA-005L-TAC	208/230	3	2.2	13	3.62	7.24					071-0090-42
HAJB-003E-IAA	115	1	4.7	31	1.23	3.1	014-0061-07		040-0166-08	RP	071-0092-04
HAJB-003L-IAA	115	1	4.7	31	1.23	3.1	014-0061-07		040-0166-08	RP	071-0092-04
HAJB-005E-CAV	208/230	1	3.7	22	3	9.455	014-0036-21	014-0064-00	040-0166-09	RP	071-0092-27
HAJB-005L-CAV	208/230	1	3.7	22	3	9.455	014-0036-21	014-0064-00	040-0166-09	RP	071-0092-27
HAK2-0033-IAA	115	1	5	31	1.23	3.1	014-0061-07		040-0166-08	RP	071-0092-04
HAK2-0033-IAB	230	1	2.4	12	5.07	12.505	014-0061-12		040-0166-19	RP	071-0092-31
HAK2-0050-IAA	115	1	6.6	43.5	0.875	2.39	014-0061-02		040-0166-08	RP	071-0092-35
HAK2-0050-IAB	230	1	4	20.2	3.48	9.6	014-0061-09		040-0166-09	RP	071-0092-05
HAT2-0033-IAA	115	1	5.2	31	1.23	3.1	014-0061-07		040-0166-08	RP	071-0092-04
HAT2-0033-IAB	230	1	2.4	12	5.07	12.505	014-0061-12		040-0166-19	RP	071-0092-31
HAT2-0050-IAA	115	1	6.9	43.5	0.875	2.39	014-0061-02		040-0166-08	RP	071-0092-35
HAT2-0050-IAB	230	1	3.9	20.2	3.48	9.6	014-0061-09		040-0166-09	RP	071-0092-05
HATB-0051-CAA	115	1	8.9	58	0.509	2.155	014-0061-02	014-0064-04	040-0166-11	RP	071-0099-03
HATB-005E-CAA	115	1	10.4	58	0.509	2.155	014-0061-02	014-0064-04	040-0166-11	RP	071-0099-03

† ‡ § \* See Section F Introduction for more information.

FC11

### Electrical Data - Copelametic - Air Cooled

Model	Volts	PH	Max RLA	LRA	Resistance		Start Cap P/N ‡	Run Cap P/N ‡	Relay P/N §	Part Type*	Protector P/N	
					Run or Line to WYE	Start or Line to Line†						
HATB-005E-CAV	208/230	1	3.3	22		3	9.455	014-0036-21	014-0064-00	040-0166-25	RP	071-0092-27
HATB-005L-CAA	115	1	10.4	58		0.509	2.155	014-0061-02	014-0064-04	040-0166-11	RP	071-0099-03
HWF2-0025-IAA	115	1	3.9	23		1.76	4.48	014-0061-06		040-0115-00	RC	071-0092-37
HWF2-0025-IAB	230	1	2.3	12.2		6.76	17.87	014-0061-13		040-0115-01	RC	071-0092-32
HWF2-0033-IAA	115	1	5.4	31		1.23	3.1	014-0061-07		040-0166-08	RP	071-0092-04
HWF2-0033-IAB	230	1	2.5	12		5.07	12.505	014-0061-12		040-0166-19	RP	071-0092-31
HWFB-003E-IAA	115	1	5.4	31		1.23	3.1	014-0061-07		040-0166-08	RP	071-0092-04
HWG1-0050-TAC	208/230	3	2.4	13		3.62	7.24					071-0090-42
HWG2-0050-CAA	115	1	8.6	44		0.755	2.36	014-0061-02	014-0064-00	040-0166-33	RP	071-0099-03
HWG2-0050-CAV	208/230	1	4	22		3	9.455	014-0036-21	014-0064-00	040-0166-09	RP	071-0092-27
HWGA-005E-TAC	208/230	3	2.4	13		3.62	7.24					071-0090-42
HWGA-005L-TAC	208/230	3	2.4	13		3.62	7.24					071-0090-42
HWGB-005E-CAV	208/230	1	4	22		3	9.455	014-0036-21	014-0064-00	040-0166-09	RP	071-0092-27
HWGB-005L-CAV	208/230	1	4	22		3	9.455	014-0036-21	014-0064-00	040-0166-09	RP	071-0092-27
HWJ1-0050-TAC	208/230	3	2.2	13		3.62	7.24					071-0090-42
HWJ2-0025-IAA	115	1	4.1	23		1.76	4.48	014-0061-06		040-0115-00	RC	071-0092-37
HWJ2-0025-IAB	230	1	2.1	12.2		6.76	17.87	014-0061-13		040-0115-01	RC	071-0092-32
HWJ2-0033-IAA	115	1	5.2	31		1.23	3.1	014-0061-07		040-0166-08	RP	071-0092-04
HWJ2-0033-IAB	230	1	2.5	12		5.07	12.505	014-0061-12		040-0166-19	RP	071-0092-31
HWJ2-0050-CAA	115	1	8.5	44		0.755	2.36	014-0061-02	014-0064-00	040-0166-33	RP	071-0099-03
HWJ2-0050-CAV	208/230	1	3.7	22		3	9.455	014-0036-21	014-0064-00	040-0166-09	RP	071-0092-27
HWJA-005E-TAC	208/230	3	2.2	13		3.62	7.24					071-0090-42
HWJA-005L-TAC	208/230	3	2.2	13		3.62	7.24					071-0090-42

† ‡ § \* See Section F Introduction for more information.

FC12

### Electrical Data - Copelametic - Air Cooled

Model	Volts	PH	Max RLA	LRA	Resistance		Start Cap P/N ‡	Run Cap P/N ‡	Relay P/N §	Part Type*	Protector P/N
					Run or Line to WYE	Start or Line to Line†					
HWJB-005E-CAV	208/230	1	3.7	22	3	9.455	014-0036-21	014-0064-00	040-0166-09	RP	071-0092-27
HWK2-0033-IAA	115	1	5	31	1.23	3.1	014-0061-07		040-0166-08	RP	071-0092-04
HWK2-0033-IAB	230	1	2.4	12	5.07	12.505	014-0061-12		040-0166-19	RP	071-0092-31
HWK2-0050-IAA	115	1	6.6	43.5	0.875	2.39	014-0061-02		040-0166-08	RP	071-0092-35
HWK2-0050-IAB	230	1	4	20.2	3.48	9.6	014-0061-09		040-0166-09	RP	071-0092-05
HWT2-0033-IAA	115	1	5.2	31	1.23	3.1	014-0061-07		040-0166-08	RP	071-0092-04
HWT2-0033-IAB	230	1	2.4	12	5.07	12.505	014-0061-12		040-0166-19	RP	071-0092-31
HWT2-0050-IAA	115	1	6.9	43.5	0.875	2.39	014-0061-02		040-0166-08	RP	071-0092-35
HWT2-0050-IAB	230	1	3.9	20.2	3.48	9.6	014-0061-09		040-0166-09	RP	071-0092-05
AAA1-0075-TAC	208/230	3	2.6	19.9	2.28	4.551					071-0090-05
AAA1-007A-TAC	208/230	3	2.6	19.9	2.28	4.551					071-0090-05
AAA2-0075-CAA	115	1	NA	44	0.57	7	014-0061-14	014-0064-02	040-0166-11	RP	071-0092-20
AAA2-0075-CAV	208/230	1	5.2	36	1.9	4.24	014-0061-04	014-0064-00	040-0166-09	RP	071-0092-29
AAA2-0075-IAA	115	1	10.2	59.8	0.59	1.4	014-0061-11		040-0166-08	RP	071-0099-00
AAA2-0075-IAB	230	1	5.4	30.4	2.34	5.53	014-0061-04		040-0166-09	RP	071-0092-27
AAA2-0075-IAH	208	1	5.6	34.1	2	5.15	014-0061-04		040-0166-09	RP	071-0092-27
AAA2-0076-CAA	115	1	8.9	65	0.519	1.266	014-0061-11	014-0064-06	040-0166-33	RP	071-0092-38
AAA2-007A-IAA	115	1	10.2	59.8	0.59	1.4	014-0061-11		040-0166-08	RP	071-0099-00
AAA2-007A-IAB	230	1	5.4	30.4	2.34	5.53	014-0061-04		040-0166-09	RP	071-0092-27
AAA2-007A-IAH	208	1	5.6	34.1	2	5.15	014-0061-04		040-0166-09	RP	071-0092-27
KAAB-0075-IAA	115	1	10.2	59.8	0.59	1.4	014-0061-11		040-0166-08	RP	071-0099-00
KAAB-007A-CAV	208/230	1	5.2	36	1.9	4.24	014-0061-04	014-0064-00	040-0166-09	RP	071-0092-29
KAAB-007A-IAA	115	1	10.2	59.8	0.59	1.4	014-0061-11		040-0166-08	RP	071-0099-00

‡ ‡ § \* See Section F Introduction for more information.

FC13

### Electrical Data - Copelametic - Air Cooled

Model	Volts	PH	Max RLA	LRA	Resistance		Start Cap P/N ‡	Run Cap P/N ‡	Relay P/N §	Part Type*	Protector P/N
					Run or Line to WYE	Start or Line to Line†					
KAAB-007E-CAA	115	1	10.2	59.8	0.59	1.4	014-0061-11	014-0064-11	040-0166-08	RP	071-0099-00
KAAB-007E-CAV	208/230	1	5.8	36	1.9	4.24	014-0061-04	014-0064-00	040-0166-09	RP	071-0092-29
KAAB-007L-CAA	115	1	10.2	59.8	0.59	1.4	014-0061-11	014-0064-11	040-0166-08	RP	071-0099-00
KAD1-0075-TAC	208/230	3	2.4	19.9	2.28	4.551					071-0090-05
KAD2-0075-CAA	115	1	9.9	65	0.519	1.266	014-0061-11	014-0064-06	040-0166-33	RP	071-0099-07
KAD2-0075-CAV	208/230	1	5.1	36	1.9	4.24	014-0061-04	014-0064-00	040-0166-09	RP	071-0092-29
KAE1-0050-TAC	208/230	3	1.9	13.2	3.34	6.69					071-0090-06
KAE1-0075-TAC	208/230	3	3.4	19.9	2.28	4.551					071-0090-41
KAE1-007L-TAC	208/230	3	3.4	19.9	2.28	4.551					071-0090-41
KAE2-0050-CAV	208/230	1	3.4	24	2.9	5.785	014-0036-21	014-0064-00	040-0166-09	RP	071-0092-37
KAE2-0050-IAA	115	1	7.8	45	0.835	2.42	014-0061-02		040-0166-08	RP	071-0092-06
KAE2-0050-IAB	230	1	4.1	22.5	3.305	9.585	014-0061-09		040-0166-09	RP	071-0092-05
KAE2-0050-IAH	208	1	4.1	25.5	2.92	7.9	014-0061-09		040-0166-09	RP	071-0092-05
KAE2-005A-IAB	230	1	4.1	22.5	3.305	9.585	014-0061-09		040-0166-09	RP	071-0092-05
KAE2-005A-IAH	208	1	4.1	25.5	2.92	7.9	014-0061-09		040-0166-09	RP	071-0092-05
KAE2-0075-CAA	115	1	10.9	65	0.519	1.266	014-0061-11	014-0064-06	040-0166-33	RP	071-0099-06
KAE2-0075-CAV	208/230	1	5.4	36	1.9	4.24	014-0061-04	014-0064-00	040-0166-09	RP	071-0092-29
KAE2-007L-CAV	208/230	1	5.4	36	1.9	4.24	014-0061-04	014-0064-00	040-0166-09	RP	071-0092-29
KAEA-005A-TAC	208/230	3	1.9	13.2	3.34	6.69					071-0090-06
KAEA-0075-TAC	208/230	3	3.4	19.9	2.28	4.551					071-0090-41
KAEA-007A-TAC	208/230	3	3.4	19.9	2.28	4.551					071-0090-41
KAEA-007E-TAC	208/230	3	3.4	19.9	2.28	4.551					071-0090-41
KAEA-007L-TAC	208/230	3	3.4	19.9	2.28	4.551					071-0090-41

† ‡ § \* See Section F Introduction for more information.

FC14

**Electrical Data - Copelametic - Air Cooled**

Model	Volts	PH	Max RLA	LRA	Resistance		Start Cap P/N ‡	Run Cap P/N ‡	Relay P/N §	Part Type*	Protector P/N
					Run or Line to WYE	Start or Line to Line†					
KAEB-005A-CAV	208/230	1	3.4	24	2.9	5.785	014-0036-21	014-0064-00	040-0166-09	RP	071-0092-37
KAEB-005A-IAA	115	1	7.8	45	0.835	2.42	014-0061-02		040-0166-08	RP	071-0092-06
KAEB-007A-CAA	115	1	10.9	65	0.519	1.266	014-0061-11	014-0064-06	040-0166-33	RP	071-0099-06
KAEB-007A-CAV	208/230	1	5.4	36	1.9	4.24	014-0061-04	014-0064-00	040-0166-09	RP	071-0092-29
KAEB-007E-CAA	115	1	10.9	65	0.519	1.266	014-0061-11	014-0064-06	040-0166-33	RP	071-0099-06
KAEB-007E-CAV	208/230	1	5.4	36	1.9	4.24	014-0061-04	014-0064-00	040-0166-09	RP	071-0092-29
KAEB-007L-CAA	115	1	10.9	65	0.519	1.266	014-0061-11	014-0064-06	040-0166-33	RP	071-0099-06
KAEB-007L-CAV	208/230	1	5.4	36	1.9	4.24	014-0061-04	014-0064-00	040-0166-09	RP	071-0092-29
KAG1-0050-TAC	208/230	3	1.9	13.2	3.34	6.69					071-0090-06
KAG1-005A-TAC	208/230	3	1.9	13.2	3.34	6.69					071-0090-06
KAG1-0075-TAC	208/230	3	2.6	19.9	2.28	4.551					071-0090-05
KAG1-0100-TAC	208/230	3	4.1	27	1.59	3.179					071-0090-16
KAG1-0100-TAD	460	3	1.6	13.5	6.24	12.48					071-0090-07
KAG2-0050-CAV	208/230	1	3.6	24	2.9	5.785	014-0036-21	014-0064-00	040-0166-09	RP	071-0092-37
KAG2-0050-IAA	115	1	7.8	45	0.835	2.42	014-0061-02		040-0166-08	RP	071-0092-06
KAG2-0050-IAB	230	1	4.1	22.5	3.305	9.585	014-0061-09		040-0166-09	RP	071-0092-05
KAG2-0050-IAH	208	1	4.1	25.5	2.92	7.9	014-0061-09		040-0166-09	RP	071-0092-05
KAG2-005A-IAA	115	1	7.8	45	0.835	2.42	014-0061-02		040-0166-08	RP	071-0092-06
KAG2-0075-CAA	115	1	NA	44	0.57	7	014-0061-14	014-0064-02	040-0166-11	RP	071-0092-20
KAG2-0075-CAV	208/230	1	5.4	36	1.9	4.24	014-0061-04	014-0064-00	040-0166-09	RP	071-0092-29
KAG2-0075-IAA	115	1	9.5	59.8	0.59	1.4	014-0061-11		040-0166-08	RP	071-0099-00
KAG2-0075-IAB	230	1	5.4	30.4	2.34	5.53	014-0061-04		040-0166-09	RP	071-0092-27
KAG2-0075-IAH	208	1	5.6	34.1	2	5.15	014-0061-04		040-0166-09	RP	071-0092-27

† ‡ § \* See Section F Introduction for more information.

FC15

### Electrical Data - Copelametic - Air Cooled

Model	Volts	PH	Max RLA	LRA	Resistance		Start Cap P/N ‡	Run Cap P/N ‡	Relay P/N §	Part Type*	Protector P/N
					Run or Line to WYE	Start or Line to Line†					
KAG2-0075-XAA	115	1	9.3	43.9	0.615	3.26	014-0061-06		040-0166-33	RP	071-0092-10
KAG2-0075-XAB	230	1	5.4	23.2	2.41	13.45	014-0061-10		040-0166-35	RP	071-0092-15
KAG2-007A-IAH	208	1	5.6	34.1	2	5.15	014-0061-04		040-0166-09	RP	071-0092-27
KAG2-0100-CAA	115	1	11.9	85.5	0.405	2.248	014-0061-05	014-0064-08	040-0166-11	RP	071-0092-40
KAG2-0100-CAV	208/230	1	6.4	40	1.37	4.525	014-0061-04	014-0064-10	040-0166-10	RP	071-0092-39
KAGA-007A-TAC	208/230	3	2.6	19.9	2.28	4.551					071-0090-05
KAGA-008E-TAC	208/230	3	3.6	23.1	2.28	4.551					071-0090-13
KAGA-010A-TAC	208/230	3	4.3	27	1.59	3.179					071-0090-50
KAGA-010E-TAC	208/230	3	4.3	27	1.59	3.179					071-0090-50
KAGA-010L-TAC	208/230	3	4.3	27	1.59	3.179					071-0090-50
KAGA-011E-TAD	460	3	2.1	15	6.62	13.24					071-0090-42
KAGA-011L-TAD	460	3	2.1	15	6.62	13.24					071-0090-42
KAGA-0150-TAC	208/230	3	5.5	35.5	1.325	2.375					071-0090-39
KAGA-0150-TAD	460	3	2.5	18.2	4.72	9.44					071-0090-27
KAGA-015A-TAC	208/230	3	5.5	35.5	1.325	2.375					071-0090-39
KAGA-015A-TAD	460	3	2.5	18.2	4.72	9.44					071-0090-27
KAGA-015L-TAC	208/230	3	5.5	35.5	1.325	2.375					071-0090-39
KAGA-015L-TAD	460	3	2.5	18.2	4.72	9.44					071-0090-27
KAGB-0050-IAA	115	1	7.8	45	0.835	2.42	014-0061-02		040-0166-08	RP	071-0092-06
KAGB-005A-CAV	208/230	1	4.1	24	2.9	5.785	014-0036-21	014-0064-00	040-0166-09	RP	071-0092-37
KAGB-005A-IAA	115	1	7.8	45	0.835	2.42	014-0061-02		040-0166-08	RP	071-0092-06
KAGB-005E-CAV	208/230	1	4.1	24	2.9	5.785	014-0036-21	014-0064-00	040-0166-09	RP	071-0092-37
KAGB-005E-IAA	115	1	7.8	45	0.835	2.42	014-0061-02		040-0166-08	RP	071-0092-06

† ‡ § \* See Section F Introduction for more information.

FC16



### Electrical Data - Copelametic - Air Cooled

Model	Volts	PH	Max RLA	LRA	Resistance		Start Cap P/N ‡	Run Cap P/N ‡	Relay P/N §	Part Type*	Protector P/N
					Run or Line to WYE	Start or Line to Line†					
KAGB-005L-IAA	115	1	7.8	45	0.835	2.42	014-0061-02		040-0166-08	RP	071-0092-06
KAGB-007A-CAV	208/230	1	5.4	36	1.9	4.24	014-0061-04	014-0064-00	040-0166-09	RP	071-0092-29
KAGB-007A-IAA	115	1	9.5	59.8	0.59	1.4	014-0061-11		040-0166-08	RP	071-0099-00
KAGB-010E-CAV	208/230	1	7.5	40	1.37	4.525	014-0061-04	014-0064-14	040-0166-10	RP	071-0092-42
KAGB-010L-CAV	208/230	1	7.5	40	1.37	4.525	014-0061-04	014-0064-14	040-0166-10	RP	071-0092-42
KAGB-0150-CAV	208/230	1	9.6	55	0.94	3.45	014-0036-22	014-0064-19	040-0166-20	RP	071-0099-04
KAGB-015A-CAV	208/230	1	9.6	55	0.94	3.45	014-0036-22	014-0064-19	040-0166-20	RP	071-0099-04
KAGB-015L-CAV	208/230	1	9.6	55	0.94	3.45	014-0036-22	014-0064-19	040-0166-20	RP	071-0099-04
KAJ1-0075-TAC	208/230	3	2.7	19.9	2.28	4.551					071-0090-05
KAJ1-0100-TAC	208/230	3	NA	25	2.145	4.29					071-0090-04
KAJ1-0100-TAD	460	3	NA	15	6.62	13.24					071-0090-07
KAJ1-010L-TAC	208/230	3	3.4	25	2.145	4.29					071-0090-04
KAJ1-010L-TAD	460	3	2.1	15	6.62	13.24					071-0090-07
KAJ3-0075-CAV	208/230	1	5.1	36	1.9	4.24	014-0061-04	014-0064-00	040-0166-09	RP	071-0092-29
KAJ3-0075-IAA	115	1	9.1	59.8	0.59	1.4	014-0061-11		040-0166-08	RP	071-0099-00
KAJ3-0075-IAB	230	1	5.4	30.4	2.34	5.53	014-0061-04		040-0166-09	RP	071-0092-27
KAJ3-0075-IAH	208	1	5.9	34.1	2	5.15	014-0061-04		040-0166-09	RP	071-0092-27
KAJ3-0075-XAA	115	1	8.9	43.9	0.615	3.26	014-0061-06		040-0166-33	RP	071-0092-10
KAJ3-0075-XAB	230	1	5.2	23.2	2.41	13.45	014-0061-10		040-0166-35	RP	071-0092-15
KAJ3-007A-IAB	230	1	5.4	30.4	2.34	5.53	014-0061-04		040-0166-09	RP	071-0092-27
KAJ3-0100-CAA	115	1	NA	85.5	0.405	2.248	014-0061-05	014-0064-08	040-0166-11	RP	071-0092-23
KAJ3-0100-CAB	230	1	NA	33.5	2.27	4.935	014-0061-04	014-0064-00	040-0166-10	RP	071-0092-25
KAJ3-0100-CAH	208	1	NA	36.4	1.885	4.59	014-0061-04	014-0064-00	040-0166-25	RP	071-0092-14

† ‡ § \* See Section F Introduction for more information.

FC17

### Electrical Data - Copelametic - Air Cooled

Model	Volts	PH	Max RLA	LRA	Resistance		Start Cap P/N †	Run Cap P/N ‡	Relay P/N §	Part Type*	Protector P/N
					Run or Line to WYE	Start or Line to Line†					
KAJ3-0100-CAV	208/230	1	NA	40	1.37	4.525	014-0061-04	014-0064-10	040-0166-10	RP	071-0092-39
KAJ3-010L-CAV	208/230	1	6.9	40	1.37	4.525	014-0061-04	014-0064-10	040-0166-10	RP	071-0092-39
KAJ8-0075-TAC	208/230	3	2.7	19.9	2.28	4.551					071-0090-05
KAJA-007A-TAC	208/230	3	2.7	19.9	2.28	4.551					071-0090-05
KAJA-0100-TAC	208/230	3	NA	25	2.145	4.29					071-0090-04
KAJA-0101-TAC	208/230	3	4.5	27	1.59	3.179					071-0090-16
KAJA-010A-TAC	208/230	3	NA	25	2.145	4.29					071-0090-04
KAJA-010L-TAC	208/230	3	3.4	25	2.145	4.29					071-0090-04
KAJA-011A-TAC	208/230	3	4.6	27	1.59	3.179					071-0090-50
KAJA-011A-TAD	460	3	2.1	15	6.62	13.24					071-0090-42
KAJA-011E-TAC	208/230	3	4.6	27	1.59	3.179					071-0090-50
KAJA-011E-TAD	460	3	2.1	15	6.62	13.24					071-0090-42
KAJA-011L-TAC	208/230	3	4.6	27	1.59	3.179					071-0090-50
KAJA-011L-TAD	460	3	2.1	15	6.62	13.24					071-0090-42
KAJB-007A-CAV	208/230	1	5.1	36	1.9	4.24	014-0061-04	014-0064-00	040-0166-09	RP	071-0092-29
KAJB-007A-IAA	115	1	10.4	59.8	0.59	1.4	014-0061-11		040-0166-08	RP	071-0099-00
KAJB-007E-IAA	115	1	10.4	59.8	0.59	1.4	014-0061-11		040-0166-08	RP	071-0099-00
KAJB-007L-IAA	115	1	10.4	59.8	0.59	1.4	014-0061-11		040-0166-08	RP	071-0099-00
KAJB-0100-CAA	115	1	NA	85.5	0.405	2.248	014-0061-05	014-0064-08	040-0166-11	RP	071-0092-23
KAJB-0100-CAV	208/230	1	NA	40	1.37	4.525	014-0061-04	014-0064-10	040-0166-10	RP	071-0092-39
KAJB-010A-CAA	115	1	NA	85.5	0.405	2.248	014-0061-05	014-0064-08	040-0166-11	RP	071-0092-23
KAJB-010A-CAV	208/230	1	6.9	40	1.37	4.525	014-0061-04	014-0064-10	040-0166-10	RP	071-0092-39
KAJB-010E-CAV	208/230	1	6.9	40	1.37	4.525	014-0061-04	014-0064-10	040-0166-10	RP	071-0092-39

† ‡ § \* See Section F Introduction for more information.

FC18

### Electrical Data - Copelametic - Air Cooled

Model	Volts	PH	Max RLA	LRA	Resistance		Start Cap P/N ‡	Run Cap P/N ‡	Relay P/N §	Part Type*	Protector P/N
					Run or Line to WYE	Start or Line to Line†					
KAJB-010L-CAV	208/230	1	6.9	40	1.37	4.525	014-0061-04	014-0064-10	040-0166-10	RP	071-0092-39
KAJC-0100-TAC	208/230	3	NA	25	2.145	4.29					071-0090-04
KAJC-0101-TAC	208/230	3	4.5	27	1.59	3.179					071-0090-16
KAJC-011L-TAC	208/230	3	4.6	27	1.59	3.179					071-0090-50
KAK1-0100-TAC	208/230	3	NA	25	2.145	4.29					071-0090-04
KAK1-0100-TAD	460	3	NA	15	6.62	13.24					071-0090-07
KAK2-0100-CAA	115	1	NA	85.5	0.405	2.248	014-0061-05	014-0064-08	040-0166-11	RP	071-0092-23
KAK2-0100-CAB	230	1	NA	33.5	2.27	4.935	014-0061-04	014-0064-00	040-0166-10	RP	071-0092-25
KAK2-0100-CAH	208	1	NA	36.4	1.885	4.59	014-0061-04	014-0064-00	040-0166-25	RP	071-0092-14
KAK2-0100-CAV	208/230	1	NA	40	1.37	4.525	014-0061-04	014-0064-10	040-0166-10	RP	071-0092-39
KAK2-010A-CAA	115	1	11.4	85.5	0.405	2.248	014-0061-05	014-0064-08	040-0166-11	RP	071-0092-23
KAK4-0075-CAV	208/230	1	NA	36	1.9	4.24	014-0061-04	014-0064-00	040-0166-09	RP	071-0092-29
KAK4-0075-IAA	115	1	NA	59.8	0.59	1.4	014-0061-11		040-0166-08	RP	071-0099-00
KAK4-0075-IAB	230	1	NA	30.4	2.34	5.53	014-0061-04		040-0166-09	RP	071-0092-27
KAK8-0100-TAC	208/230	3	3.3	25	2.145	4.29					071-0090-04
KAKA-0100-TAC	208/230	3	NA	25	2.145	4.29					071-0090-04
KAKA-010A-TAC	208/230	3	3.3	25	2.145	4.29					071-0090-04
KAKA-010A-TAD	460	3	NA	15	6.62	13.24					071-0090-07
KAKA-010L-TAC	208/230	3	3.3	25	2.145	4.29					071-0090-04
KAKA-011E-TAD	460	3	2.4	15	6.62	13.24					071-0090-42
KAKA-012E-TAC	208/230	3	4.6	27	1.59	3.179					071-0090-03
KAKA-0150-TAU	200	3	6.6	48.2	0	1.463					071-0090-28
KAKA-0200-TAC	208/230	3	6.8	50	0.795	1.589					071-0090-35

† ‡ § \* See Section F Introduction for more information.

FC19

### Electrical Data - Copelametic - Air Cooled

Model	Volts	PH	Max RLA	LRA	Resistance		Start Cap P/N ‡	Run Cap P/N ‡	Relay P/N §	Part Type*	Protector P/N
					Run or Line to WYE	Start or Line to Line†					
KAKA-0200-TAD	460	3	3	25	3.165	6.329					071-0090-16
KAKA-020A-TAC	208/230	3	6.8	50	0.795	1.589					071-0090-35
KAKA-020A-TAD	460	3	3	25	3.165	6.329					071-0090-16
KAKA-020E-TAC	208/230	3	6.8	50	0.795	1.589					071-0090-35
KAKA-020L-TAC	208/230	3	6.5	50	0.795	1.589					071-0090-35
KAKA-020L-TAD	460	3	3	25	3.165	6.329					071-0090-16
KAKA-022E-TAD	460	3	3	25	3.165	6.329					071-0090-16
KAKB-011A-CAV	208/230	1	7.9	40	1.37	4.525	014-0061-04	014-0064-14	040-0166-10	RP	071-0092-42
KAKB-011E-CAV	208/230	1	7.9	40	1.37	4.525	014-0061-04	014-0064-14	040-0166-10	RP	071-0092-42
KAKB-011L-CAV	208/230	1	7.9	40	1.37	4.525	014-0061-04	014-0064-14	040-0166-10	RP	071-0092-42
KAKB-012E-CAA	115	1	11.4	85.5	0.405	2.248	014-0061-05	014-0064-08	040-0166-11	RP	071-0092-23
KAKB-0150-CAB	230	1	7.5	44	1.65	4.19	014-0036-21	014-0064-11	040-0166-20	RP	071-0092-29
KAKB-0151-CAB	230	1	8.5	44	1.28	4.105	014-0036-21	014-0064-19	040-0166-20	RP	071-0099-03
KAKB-015A-CAB	230	1	7.5	44	1.65	4.19	014-0036-21	014-0064-11	040-0166-20	RP	071-0092-29
KAKB-0200-CAV	208/230	1	9.1	55	0.94	3.45	014-0036-22	014-0064-19	040-0166-20	RP	071-0099-04
KAKB-020L-CAV	208/230	1	9.1	55	0.94	3.45	014-0036-22	014-0064-19	040-0166-20	RP	071-0099-04
KAKB-021A-CAV	208/230	1	9.1	55	0.94	3.45	014-0036-22	014-0064-19	040-0166-20	RP	071-0099-04
KAKB-021E-CAV	208/230	1	10.6	55	0.94	3.45	014-0036-22	014-0064-14	040-0166-20	RP	071-0099-04
KAKB-021L-CAV	208/230	1	10.1	55	0.94	3.45	014-0036-22	014-0064-14	040-0166-20	RP	071-0099-04
KAKC-0150-TAU	200	3	6.6	48.2	0	1.463					071-0090-28
KAKC-0200-TAC	208/230	3	6.8	50	0.795	1.589					071-0090-35
KAKC-020L-TAC	208/230	3	6.5	50	0.795	1.589					071-0090-35
KAKD-011E-CAV	208/230	1	7.9	40	1.37	4.525	014-0061-04	014-0064-14	040-0166-10	RP	071-0092-42

† ‡ § \* See Section F Introduction for more information.

FC20

### Electrical Data - Copelametic - Air Cooled

Model	Volts	PH	Max RLA	LRA	Resistance		Start Cap P/N ‡	Run Cap P/N ‡	Relay P/N §	Part Type*	Protector P/N
					Run or Line to WYE	Start or Line to Line†					
KAL1-0100-TAC	208/230	3	NA	25	2.145	4.29					071-0090-04
KAL1-0100-TAD	460	3	NA	15	6.62	13.24					071-0090-07
KAL2-0100-CAA	115	1	NA	85.5	0.405	2.248	014-0061-05	014-0064-08	040-0166-11	RP	071-0092-23
KAL2-0100-CAB	230	1	NA	33.5	2.27	4.935	014-0061-04	014-0064-00	040-0166-10	RP	071-0092-25
KAL2-0100-CAH	208	1	NA	36.4	1.885	4.59	014-0061-04	014-0064-00	040-0166-25	RP	071-0092-14
KAL2-0100-CAV	208/230	1	NA	40	1.37	4.525	014-0061-04	014-0064-10	040-0166-10	RP	071-0092-39
KALA-0100-TAC	208/230	3	3.3	25	2.145	4.29					071-0090-04
KALA-0100-TAD	460	3	1.8	15	6.62	13.24					071-0090-07
KALA-010A-TAC	208/230	3	3.3	25	2.145	4.29					071-0090-04
KALA-010A-TAD	460	3	1.8	15	6.62	13.24					071-0090-07
KALA-0150-TAC	208/230	3	NA	35.5	1.325	2.375					071-0090-03
KALA-0150-TAD	460	3	NA	18.2	4.72	9.44					071-0090-27
KALA-0150-TAU	200	3	NA	48.2	0	1.463					071-0090-28
KALA-015A-TAC	208/230	3	5.4	35.5	1.325	2.375					071-0090-03
KALA-015A-TAD	460	3	2.9	18.2	4.72	9.44					071-0090-27
KALA-015L-TAC	208/230	3	5.4	35.5	1.325	2.375					071-0090-03
KALA-015L-TAD	460	3	2.9	18.2	4.72	9.44					071-0090-27
KALA-016E-TAC	208/230	3	6.6	50	0.795	1.589					071-0090-35
KALA-016E-TAD	460	3	3.4	25	3.165	6.329					071-0090-16
KALA-016L-TAC	208/230	3	6.6	50	0.795	1.589					071-0090-35
KALA-016L-TAD	460	3	3.4	25	3.165	6.329					071-0090-16
KALB-0100-CAA	115	1	10.9	85.5	0.405	2.248	014-0061-05	014-0064-08	040-0166-11	RP	071-0092-23
KALB-0100-CAB	230	1	5.5	33.5	2.27	4.935	014-0061-04	014-0064-00	040-0166-10	RP	071-0092-25

† ‡ § \* See Section F Introduction for more information.

FC21

### Electrical Data - Copelametic - Air Cooled

Model	Volts	PH	Max RLA	LRA	Resistance		Start Cap P/N ‡	Run Cap P/N ‡	Relay P/N §	Part Type*	Protector P/N
					Run or Line to WYE	Start or Line to Line†					
KALB-0100-CAH	208	1	6.8	36.4	1.885	4.59	014-0061-04	014-0064-00	040-0166-25	RP	071-0092-14
KALB-0100-CAV	208/230	1	6.9	40	1.37	4.525	014-0061-04	014-0064-10	040-0166-10	RP	071-0092-39
KALB-010A-CAA	115	1	10.9	85.5	0.405	2.248	014-0061-05	014-0064-08	040-0166-11	RP	071-0092-23
KALB-010A-CAB	230	1	5.5	33.5	2.27	4.935	014-0061-04	014-0064-00	040-0166-10	RP	071-0092-25
KALB-010A-CAV	208/230	1	6.9	40	1.37	4.525	014-0061-04	014-0064-10	040-0166-10	RP	071-0092-39
KALB-010E-CAV	208/230	1	6.9	40	1.37	4.525	014-0061-04	014-0064-10	040-0166-10	RP	071-0092-39
KALB-010L-CAV	208/230	1	6.9	40	1.37	4.525	014-0061-04	014-0064-10	040-0166-10	RP	071-0092-39
KALB-0150-CAB	230	1	NA	44	1.65	4.19	014-0036-21	014-0064-10	040-0166-20	RP	071-0092-16
KALB-0150-CAH	208	1	NA	45	1.32	4.19	014-0036-21	014-0064-10	040-0166-30	RP	071-0092-18
KALB-0150-CAV	208/230	1	NA	55	0.94	3.45	014-0036-22	014-0064-19	040-0166-20	RP	071-0099-04
KALB-0151-CAB	230	1	8.9	44	1.28	4.105	014-0036-21	014-0064-19	040-0166-20	RP	071-0099-03
KALB-015A-CAB	230	1	5.6	44	1.65	4.19	014-0036-21	014-0064-10	040-0166-20	RP	071-0092-16
KALB-015A-CAH	208	1	8.1	45	1.32	4.19	014-0036-21	014-0064-10	040-0166-30	RP	071-0092-18
KALB-015A-CAV	208/230	1	9.9	55	0.94	3.45	014-0036-22	014-0064-19	040-0166-20	RP	071-0099-04
KALB-015E-CAV	208/230	1	9.9	55	0.94	3.45	014-0036-22	014-0064-19	040-0166-20	RP	071-0099-04
KALB-015L-CAV	208/230	1	9.9	55	0.94	3.45	014-0036-22	014-0064-19	040-0166-20	RP	071-0099-04
KALC-0150-TAU	200	3	NA	48.2	0	1.463					071-0090-28
KALC-016L-TAC	208/230	3	6.6	50	0.795	1.589					071-0090-35
KAM1-0050-TAC	208/230	3	1.7	13.2	3.34	6.69					071-0090-06
KAM1-0075-TAC	208/230	3	NA	19.9	2.28	4.551					071-0090-05
KAM1-0100-TAC	208/230	3	4.5	27	1.59	3.179					071-0090-40
KAM1-0100-TAD	460	3	2.2	13.5	6.24	12.48					071-0090-43
KAM1-010A-TAD	460	3	2.2	13.5	6.24	12.48					071-0090-43

† ‡ § \* See Section F Introduction for more information.

FC22

**Electrical Data - Copelametic - Air Cooled**

Model	Volts	PH	Max RLA	LRA	Resistance		Start Cap P/N ‡	Run Cap P/N ‡	Relay P/N §	Part Type*	Protector P/N
					Run or Line to WYE	Start or Line to Line†					
KAM1-010L-TAC	208/230	3	4.5	27	1.59	3.179					071-0090-40
KAM1-010L-TAD	460	3	2.2	13.5	6.24	12.48					071-0090-43
KAM2-0050-CAV	208/230	1	3.7	24	2.9	5.785	014-0036-21	014-0064-00	040-0166-09	RP	071-0092-37
KAM2-0050-IAA	115	1	7.2	45	0.835	2.42	014-0061-02		040-0166-08	RP	071-0092-06
KAM2-0050-IAB	230	1	3.8	22.5	3.305	9.585	014-0061-09		040-0166-09	RP	071-0092-05
KAM2-0050-IAH	208	1	3.8	25.5	2.92	7.9	014-0061-09		040-0166-09	RP	071-0092-05
KAM2-0075-CAV	208/230	1	5.6	36	1.9	4.24	014-0061-04	014-0064-00	040-0166-09	RP	071-0092-29
KAM2-0075-IAA	115	1	NA	59.8	0.59	1.4	014-0061-11		040-0166-08	RP	071-0099-00
KAM2-0075-IAB	230	1	NA	30.4	2.34	5.53	014-0061-04		040-0166-09	RP	071-0092-27
KAM2-0075-IAH	208	1	6.1	34.1	2	5.15	014-0061-04		040-0166-09	RP	071-0092-27
KAM2-0075-XAA	115	1	8.9	43.9	0.615	3.26	014-0061-06		040-0166-33	RP	071-0092-10
KAM2-0075-XAB	230	1	6	23.2	2.41	13.45	014-0061-10		040-0166-35	RP	071-0092-15
KAM2-0100-CAA	115	1	15.5	93	0.376	1.837	014-0061-05	014-0064-08	040-0166-11	RP	071-0099-05
KAM2-0100-CAV	208/230	1	7.5	40	1.37	4.525	014-0061-04	014-0064-10	040-0166-10	RP	071-0092-39
KAM2-010A-CAA	115	1	15.5	93	0.376	1.837	014-0061-05	014-0064-08	040-0166-11	RP	071-0099-05
KAM2-010L-CAV	208/230	1	7.5	40	1.37	4.525	014-0061-04	014-0064-10	040-0166-10	RP	071-0092-39
KAMA-0050-TAC	208/230	3	1.7	13.2	3.34	6.69					071-0090-06
KAMA-005A-TAC	208/230	3	1.7	13.2	3.34	6.69					071-0090-06
KAMA-0075-TAC	208/230	3	NA	19.9	2.28	4.551					071-0090-41
KAMA-007A-TAC	208/230	3	3.2	19.9	2.28	4.551					071-0090-41
KAMA-007E-TAC	208/230	3	3.2	19.9	2.28	4.551					071-0090-41
KAMA-007L-TAC	208/230	3	3.2	19.9	2.28	4.551					071-0090-41
KAMA-0100-TAC	208/230	3	4.5	27	1.59	3.179					071-0090-40

† ‡ § \* See Section F Introduction for more information.

FC23

### Electrical Data - Copelametic - Air Cooled

Model	Volts	PH	Max RLA	LRA	Resistance		Start Cap P/N ‡	Run Cap P/N ‡	Relay P/N §	Part Type*	Protector P/N
					Run or Line to WYE	Start or Line to Line†					
KAMA-010A-TAC	208/230	3	4.5	27	1.59	3.179					071-0090-40
KAMB-0050-CAV	208/230	1	3.7	24	2.9	5.785	014-0036-21	014-0064-00	040-0166-09	RP	071-0092-37
KAMB-0050-IAA	115	1	7.2	45	0.835	2.42	014-0061-02		040-0166-08	RP	071-0092-06
KAMB-0050-IAB	230	1	3.8	22.5	3.305	9.585	014-0061-09		040-0166-09	RP	071-0092-05
KAMB-0050-IAH	208	1	3.8	25.5	2.92	7.9	014-0061-09		040-0166-09	RP	071-0092-05
KAMB-005A-CAV	208/230	1	3.7	24	2.9	5.785	014-0036-21	014-0064-00	040-0166-09	RP	071-0092-37
KAMB-005A-IAA	115	1	7.2	45	0.835	2.42	014-0061-02		040-0166-08	RP	071-0092-06
KAMB-005A-IAB	230	1	3.8	22.5	3.305	9.585	014-0061-09		040-0166-09	RP	071-0092-05
KAMB-005A-IAH	208	1	3.8	25.5	2.92	7.9	014-0061-09		040-0166-09	RP	071-0092-05
KAMB-0075-CAA	115	1	NA	85.5	0.405	2.248	014-0061-05	014-0064-08	040-0166-11	RP	071-0092-40
KAMB-0075-CAV	208/230	1	NA	36	1.9	4.24	014-0061-04	014-0064-00	040-0166-09	RP	071-0092-29
KAMB-0075-IAB	230	1	NA	30.4	2.34	5.53	014-0061-04		040-0166-09	RP	071-0092-27
KAMB-0075-IAH	208	1	NA	34.1	2	5.15	014-0061-04		040-0166-09	RP	071-0092-27
KAMB-007A-CAA	115	1	NA	85.5	0.405	2.248	014-0061-05	014-0064-08	040-0166-21	RP	071-0092-40
KAMB-007A-CAV	208/230	1	5.6	36	1.9	4.24	014-0061-04	014-0064-00	040-0166-09	RP	071-0092-29
KAMB-007E-CAA	115	1	10.9	85.5	0.405	2.248	014-0061-05	014-0064-08	040-0166-21	RP	071-0092-40
KAMB-007E-CAV	208/230	1	5.6	36	1.9	4.24	014-0061-04	014-0064-00	040-0166-09	RP	071-0092-29
KAMB-007E-IAA	115	1	10.1	59.8	0.59	1.4	014-0061-11		040-0166-08	RP	071-0099-00
KAMB-007L-CAA	115	1	10.9	85.5	0.405	2.248	014-0061-05	014-0064-08	040-0166-21	RP	071-0092-40
KAMB-007L-CAV	208/230	1	5.6	36	1.9	4.24	014-0061-04	014-0064-00	040-0166-09	RP	071-0092-29
KAMB-010A-CAV	208/230	1	7.5	40	1.37	4.525	014-0061-04	014-0064-10	040-0166-10	RP	071-0092-39
KAMC-0075-TAC	208/230	3	NA	19.9	2.28	4.551					071-0090-41
KAMD-007E-CAA	115	1	10.9	85.5	0.405	2.248	014-0061-05	014-0064-08	040-0166-21	RP	071-0092-40

† ‡ § \* See Section F Introduction for more information.

FC24



**Electrical Data - Copelametic - Air Cooled**

Model	Volts	PH	Max RLA	LRA	Resistance		Start Cap P/N ‡	Run Cap P/N ‡	Relay P/N §	Part Type*	Protector P/N
					Run or Line to WYE	Start or Line to Line†					
KAMD-007E-CAV	208/230	1	5.6	36	1.9	4.24	014-0061-04	014-0064-00	040-0166-09	RP	071-0092-29
KAN1-0050-TAC	208/230	3	2.1	13.2	3.34	6.69					071-0090-06
KAN1-0075-TAC	208/230	3	3.5	19.9	2.28	4.551					071-0090-41
KAN1-007L-TAC	208/230	3	3.5	19.9	2.28	4.551					071-0090-41
KAN2-0050-CAV	208/230	1	3.6	24	2.9	5.785	014-0036-21	014-0064-00	040-0166-09	RP	071-0092-37
KAN2-0050-IAA	115	1	8.1	45	0.835	2.42	014-0061-02		040-0166-08	RP	071-0092-06
KAN2-0050-IAB	230	1	4.2	22.5	3.305	9.585	014-0061-09		040-0166-09	RP	071-0092-05
KAN2-0050-IAH	208	1	4.2	25.5	2.92	7.9	014-0061-09		040-0166-09	RP	071-0092-05
KAN2-0075-CAA	115	1	11.7	65	0.519	1.266	014-0061-11	014-0064-06	040-0166-33	RP	071-0099-06
KAN2-0075-CAV	208/230	1	6.1	36	1.9	4.24	014-0061-04	014-0064-00	040-0166-09	RP	071-0092-41
KAN2-007A-CAA	115	1	11.7	65	0.519	1.266	014-0061-11	014-0064-06	040-0166-33	RP	071-0099-06
KAN2-007L-CAV	208/230	1	6.1	36	1.9	4.24	014-0061-04	014-0064-00	040-0166-09	RP	071-0092-41
KANA-006E-TAC	208/230	3	2.2	13.2	3.34	6.69					071-0090-21
KANA-006L-TAC	208/230	3	2.2	13.2	3.34	6.69					071-0090-21
KANA-0075-TAC	208/230	3	3.5	19.9	2.28	4.551					071-0090-41
KANA-007E-TAC	208/230	3	3.5	19.9	2.28	4.551					071-0090-41
KANB-0050-CAV	208/230	1	3.6	24	2.9	5.785	014-0036-21	014-0064-00	040-0166-09	RP	071-0092-37
KANB-0050-IAA	115	1	NA	45	0.835	2.42	014-0061-02		040-0166-08	RP	071-0092-06
KANB-005A-CAV	208/230	1	3.6	24	2.9	5.785	014-0036-21	014-0064-00	040-0166-09	RP	071-0092-37
KANB-005A-IAA	115	1	8	45	0.835	2.42	014-0061-02		040-0166-08	RP	071-0092-06
KANB-005E-CAV	208/230	1	3.6	24	2.9	5.785	014-0036-21	014-0064-00	040-0166-09	RP	071-0092-37
KANB-005E-IAA	115	1	8	45	0.835	2.42	014-0061-02		040-0166-08	RP	071-0092-06
KANB-005L-CAV	208/230	1	3.6	24	2.9	5.785	014-0036-21	014-0064-00	040-0166-09	RP	071-0092-37

† ‡ § \* See Section F Introduction for more information.

FC25

### Electrical Data - Copelametic - Air Cooled

Model	Volts	PH	Max RLA	LRA	Resistance		Start Cap P/N ‡	Run Cap P/N ‡	Relay P/N §	Part Type*	Protector P/N
					Run or Line to WYE	Start or Line to Line†					
KANB-005L-IAA	115	1	8	45	0.835	2.42	014-0061-02		040-0166-08	RP	071-0092-06
KANB-007E-CAV	208/230	1	NA	36		1.9	014-0061-04	014-0064-00	040-0166-09	RP	071-0092-41
KAR1-0100-TAC	208/230	3	4.3	27		1.59					071-0090-40
KAR1-0100-TAD	460	3	2.2	13.5		6.24					071-0090-43
KAR1-010L-TAC	208/230	3	4.3	27		1.59					071-0090-40
KAR1-010L-TAD	460	3	2.2	13.5		6.24					071-0090-43
KAR2-0100-CAA	115	1	15.4	93		0.376	014-0061-05	014-0064-08	040-0166-11	RP	071-0099-05
KAR2-0100-CAV	208/230	1	7.4	40		1.37	014-0061-04	014-0064-10	040-0166-10	RP	071-0092-39
KAR2-010A-CAA	115	1	15.4	93		0.376	014-0061-05	014-0064-08	040-0166-11	RP	071-0099-05
KAR2-010L-CAV	208/230	1	7.4	40		1.37	014-0061-04	014-0064-10	040-0166-10	RP	071-0092-39
KARA-0100-TAC	208/230	3	4.3	27		1.59					071-0090-40
KARA-010A-TAC	208/230	3	4.3	27		1.59					071-0090-40
KARA-010E-TAC	208/230	3	4.3	27		1.59					071-0090-40
KARA-010L-TAC	208/230	3	4.3	27		1.59					071-0090-40
KARA-011A-TAD	460	3	2	15		6.62					071-0090-42
KARA-011E-TAD	460	3	2	15		6.62					071-0090-42
KARA-011L-TAD	460	3	2	15		6.62					071-0090-42
KARB-010A-CAV	208/230	1	7.4	40		1.37	014-0061-04	014-0064-10	040-0166-10	RP	071-0092-39
KARB-010E-CAV	208/230	1	7.4	40		1.37	014-0061-04	014-0064-10	040-0166-10	RP	071-0092-39
KARB-010L-CAV	208/230	1	7.4	40		1.37	014-0061-04	014-0064-10	040-0166-10	RP	071-0092-39
KAT4-0100-CAA	115	1	NA	85.5		0.405	014-0061-05	014-0064-08	040-0166-11	RP	071-0092-23
KAT4-0100-CAB	230	1	NA	33.5		2.27	014-0061-04	014-0064-00	040-0166-10	RP	071-0092-25
KAT4-0100-CAV	208/230	1	NA	40		1.37	014-0061-04	014-0064-10	040-0166-10	RP	071-0092-39

† ‡ § \* See Section F Introduction for more information.

FC26

**Electrical Data - Copelametic - Air Cooled**

Model	Volts	PH	Max RLA	LRA	Resistance		Start Cap P/N ‡	Run Cap P/N ‡	Relay P/N §	Part Type*	Protector P/N
					Run or Line to WYE	Start or Line to Line†					
KATA-0100-TAC	208/230	3	3.9	25	2.145	4.29					071-0090-04
KATA-0100-TAD	460	3	2.1	15	6.62	13.24					071-0090-07
KATA-010A-TAC	208/230	3	3.9	25	2.145	4.29					071-0090-04
KATA-010A-TAD	460	3	2.1	15	6.62	13.24					071-0090-07
KATA-0150-TAC	208/230	3	NA	35.5	1.325	2.375					071-0090-03
KATA-0150-TAD	460	3	NA	18.2	4.72	9.44					071-0090-27
KATA-0151-TAC	208/230	3	6	50	0.795	1.589					071-0090-22
KATA-015A-TAC	208/230	3	5	35.5	1.325	2.375					071-0090-03
KATA-015A-TAD	460	3	2.9	18.2	4.72	9.44					071-0090-27
KATA-015E-TAC	208/230	3	5	35.5	1.325	2.375					071-0090-03
KATA-015E-TAD	460	3	2.9	18.2	4.72	9.44					071-0090-27
KATA-015L-TAC	208/230	3	5	35.5	1.325	2.375					071-0090-03
KATA-0200-TAU	200	3	6.4	51	0	1.44					071-0090-31
KATA-020E-TAU	200	3	6.4	51	0	1.44					071-0090-31
KATA-020L-TAU	200	3	6.4	51	0	1.44					071-0090-31
KATB-0100-CAA	115	1	12.4	85.5	0.405	2.248	014-0061-05	014-0064-08	040-0166-11	RP	071-0092-23
KATB-0100-CAB	230	1	5.5	33.5	2.27	4.935	014-0061-04	014-0064-00	040-0166-10	RP	071-0092-25
KATB-0100-CAH	208	1	7.3	36.4	1.885	4.59	014-0061-04	014-0064-00	040-0166-25	RP	071-0092-14
KATB-0100-CAV	208/230	1	7.2	40	1.37	4.525	014-0061-04	014-0064-10	040-0166-10	RP	071-0092-39
KATB-010A-CAA	115	1	12.4	85.5	0.405	2.248	014-0061-05	014-0064-08	040-0166-11	RP	071-0092-23
KATB-010A-CAB	230	1	5.5	33.5	2.27	4.935	014-0061-04	014-0064-00	040-0166-10	RP	071-0092-25
KATB-010A-CAV	208/230	1	7.2	40	1.37	4.525	014-0061-04	014-0064-10	040-0166-10	RP	071-0092-39
KATB-0150-CAB	230	1	NA	44	1.65	4.19	014-0036-21	014-0064-10	040-0166-20	RP	071-0092-18

† ‡ § \* See Section F Introduction for more information.

FC27

### Electrical Data - Copelametic - Air Cooled

Model	Volts	PH	Max RLA	LRA	Resistance		Start Cap P/N ‡	Run Cap P/N ‡	Relay P/N §	Part Type*	Protector P/N
					Run or Line to WYE	Start or Line to Line†					
KATB-0150-CAH	208	1	7.8	45	1.32	4.19	014-0036-21	014-0064-10	040-0166-30	RP	071-0092-18
KATB-0150-CAV	208/230	1	NA	55	0.94	3.45	014-0036-22	014-0064-19	040-0166-20	RP	071-0099-04
KATB-0151-CAB	230	1	7.4	44	1.28	4.105	014-0036-21	014-0064-19	040-0166-20	RP	071-0092-18
KATB-015A-CAB	230	1	6.1	44	1.65	4.19	014-0036-21	014-0064-10	040-0166-20	RP	071-0092-18
KATB-015A-CAH	208	1	7.8	45	1.32	4.19	014-0036-21	014-0064-10	040-0166-30	RP	071-0092-18
KATB-015A-CAV	208/230	1	NA	55	0.94	3.45	014-0036-22	014-0064-19	040-0166-20	RP	071-0099-04
KATB-015E-CAV	208/230	1	9	55	0.94	3.45	014-0036-22	014-0064-19	040-0166-20	RP	071-0099-04
KATB-015L-CAV	208/230	1	9	55	0.94	3.45	014-0036-22	014-0064-19	040-0166-20	RP	071-0099-04
KATC-0150-TAC	208/230	3	NA	35.5	1.325	2.375					071-0090-03
KATC-0200-TAU	200	3	6.4	51	0	1.44					071-0090-31
KATC-020E-TAD	460	3	3.5	25	3.165	6.329					071-0090-13
KATC-020E-TAU	200	3	6.4	51	0	1.44					071-0090-31
KATC-020L-TAU	200	3	6.4	51	0	1.44					071-0090-31
KATD-015E-CAV	208/230	1	9	55	0.94	3.45	014-0036-22	014-0064-19	040-0166-20	RP	071-0099-04
KWA1-0075-TAC	208/230	3	2.6	19.9	2.28	4.551					071-0090-05
KWA2-0075-CAV	208/230	1	5.2	36	1.9	4.24	014-0061-04	014-0064-00	040-0166-09	RP	071-0092-29
KWA2-0075-IAA	115	1	10.2	59.8	0.59	1.4	014-0061-11		040-0166-08	RP	071-0099-00
KWA2-0075-IAB	230	1	5.4	30.4	2.34	5.53	014-0061-04		040-0166-09	RP	071-0092-27
KWA2-0075-IAH	208	1	5.6	34.1	2	5.15	014-0061-04		040-0166-09	RP	071-0092-27
KWD1-0075-TAC	208/230	3	2.4	19.9	2.28	4.551					071-0090-05
KWD2-0075-CAA	115	1	9.9	65	0.519	1.266	014-0061-11	014-0064-06	040-0166-33	RP	071-0099-07
KWD2-0075-CAV	208/230	1	5.1	36	1.9	4.24	014-0061-04	014-0064-00	040-0166-09	RP	071-0092-29
KWE1-0050-TAC	208/230	3	1.9	13.2	3.34	6.69					071-0090-06

† ‡ § \* See Section F Introduction for more information.

FC28

**Electrical Data - Copelametic - Air Cooled**

Model	Volts	PH	Max RLA	LRA	Resistance		Start Cap P/N ‡	Run Cap P/N ‡	Relay P/N §	Part Type*	Protector P/N
					Run or Line to WYE	Start or Line to Line†					
KWE1-0075-TAC	208/230	3	3.4	19.9	2.28	4.551					071-0090-41
KWE2-0050-CAV	208/230	1	3.4	24	2.9	5.785	014-0036-21	014-0064-00	040-0166-09	RP	071-0092-37
KWE2-0050-IAA	115	1	7.8	45	0.835	2.42	014-0061-02		040-0166-08	RP	071-0092-06
KWE2-0050-IAB	230	1	4.1	22.5	3.305	9.585	014-0061-09		040-0166-09	RP	071-0092-05
KWE2-0050-IAH	208	1	4.1	25.5	2.92	7.9	014-0061-09		040-0166-09	RP	071-0092-05
KWE2-0075-CAA	115	1	10.9	65	0.519	1.266	014-0061-11	014-0064-06	040-0166-33	RP	071-0099-06
KWE2-0075-CAV	208/230	1	5.4	36	1.9	4.24	014-0061-04	014-0064-00	040-0166-09	RP	071-0092-29
KWG1-0050-TAC	208/230	3	1.9	13.2	3.34	6.69					071-0090-06
KWG1-0075-TAC	208/230	3	2.6	19.9	2.28	4.551					071-0090-05
KWG1-0100-TAC	208/230	3	4.1	27	1.59	3.179					071-0090-16
KWG1-0100-TAD	460	3	1.6	13.5	6.24	12.48					071-0090-07
KWG2-0050-CAV	208/230	1	3.6	24	2.9	5.785	014-0036-21	014-0064-00	040-0166-09	RP	071-0092-37
KWG2-0050-IAA	115	1	7.8	45	0.835	2.42	014-0061-02		040-0166-08	RP	071-0092-06
KWG2-0050-IAB	230	1	4.1	22.5	3.305	9.585	014-0061-09		040-0166-09	RP	071-0092-05
KWG2-0050-IAH	208	1	4.1	25.5	2.92	7.9	014-0061-09		040-0166-09	RP	071-0092-05
KWG2-0075-CAV	208/230	1	5.4	36	1.9	4.24	014-0061-04	014-0064-00	040-0166-09	RP	071-0092-29
KWG2-0075-IAA	115	1	9.5	59.8	0.59	1.4	014-0061-11		040-0166-08	RP	071-0099-00
KWG2-0075-IAB	230	1	5.4	30.4	2.34	5.53	014-0061-04		040-0166-09	RP	071-0092-27
KWG2-0075-IAH	208	1	5.6	34.1	2	5.15	014-0061-04		040-0166-09	RP	071-0092-27
KWG2-0100-CAA	115	1	11.9	85.5	0.405	2.248	014-0061-05	014-0064-08	040-0166-11	RP	071-0092-40
KWG2-0100-CAV	208/230	1	6.4	40	1.37	4.525	014-0061-04	014-0064-10	040-0166-10	RP	071-0092-39
KWGA-010E-TAC	208/230	3	4.3	27	1.59	3.179					071-0090-50
KWGA-010L-TAC	208/230	3	4.3	27	1.59	3.179					071-0090-50

† ‡ § \* See Section F Introduction for more information.

FC29

### Electrical Data - Copelametic - Air Cooled

Model	Volts	PH	Max RLA	LRA	Resistance		Start Cap P/N ‡	Run Cap P/N ‡	Relay P/N §	Part Type*	Protector P/N
					Run or Line to WYE	Start or Line to Line†					
KWGA-011E-TAD	460	3	2.1	15	6.62	13.24					071-0090-42
KWGA-011L-TAD	460	3	2.1	15	6.62	13.24					071-0090-42
KWGA-0150-TAC	208/230	3	5.5	35.5	1.325	2.375					071-0090-39
KWGA-0150-TAD	460	3	2.5	18.2	4.72	9.44					071-0090-27
KWGA-015A-TAC	208/230	3	5.5	35.5	1.325	2.375					071-0090-39
KWGB-010E-CAV	208/230	1	7.5	40	1.37	4.525	014-0061-04	014-0064-14	040-0166-10	RP	071-0092-42
KWGB-010L-CAV	208/230	1	7.5	40	1.37	4.525	014-0061-04	014-0064-14	040-0166-10	RP	071-0092-42
KWGB-0150-CAV	208/230	1	9.6	55	0.94	3.45	014-0036-22	014-0064-19	040-0166-20	RP	071-0099-04
KWJ1-0075-TAC	208/230	3	2.7	19.9	2.28	4.551					071-0090-05
KWJ1-0100-TAC	208/230	3	3.4	25	2.145	4.29					071-0090-04
KWJ1-0100-TAD	460	3	2.1	15	6.62	13.24					071-0090-07
KWJ3-0075-CAV	208/230	1	5.1	36	1.9	4.24	014-0061-04	014-0064-00	040-0166-09	RP	071-0092-29
KWJ3-0075-IAA	115	1	9.1	59.8	0.59	1.4	014-0061-11		040-0166-08	RP	071-0099-00
KWJ3-0075-IAB	230	1	5.4	30.4	2.34	5.53	014-0061-04		040-0166-09	RP	071-0092-27
KWJ3-0075-IAH	208	1	5.9	34.1	2	5.15	014-0061-04		040-0166-09	RP	071-0092-27
KWJ3-0100-CAA	115	1	12.4	85.5	0.405	2.248	014-0061-05	014-0064-08	040-0166-11	RP	071-0092-23
KWJ3-0100-CAB	230	1	5.4	33.5	2.27	4.935	014-0061-04	014-0064-00	040-0166-10	RP	071-0092-25
KWJ3-0100-CAH	208	1	6.9	36.4	1.885	4.59	014-0061-04	014-0064-00	040-0166-25	RP	071-0092-14
KWJ3-0100-CAV	208/230	1	6.9	40	1.37	4.525	014-0061-04	014-0064-10	040-0166-10	RP	071-0092-39
KWJA-0101-TAC	208/230	3	4.5	27	1.59	3.179					071-0090-16
KWJA-010A-TAC	208/230	3	NA	25	2.145	4.29					071-0090-04
KWJA-011A-TAC	208/230	3	4.6	27	1.59	3.179					071-0090-50
KWJA-011A-TAD	460	3	2	15	6.62	13.24					071-0090-42

† ‡ § \* See Section F Introduction for more information.

FC30

### Electrical Data - Copelametic - Air Cooled

Model	Volts	PH	Max RLA	LRA	Resistance		Start Cap P/N ‡	Run Cap P/N ‡	Relay P/N §	Part Type*	Protector P/N
					Run or Line to WYE	Start or Line to Line†					
KWJA-011E-TAC	208/230	3	4.6	27	1.59	3.179					071-0090-50
KWJA-011E-TAD	460	3	2.1	15	6.62	13.24					071-0090-42
KWJB-0100-CAV	208/230	1	6.9	40	1.37	4.525	014-0061-04	014-0064-10	040-0166-10	RP	071-0092-39
KWJB-010E-CAV	208/230	1	6.9	40	1.37	4.525	014-0061-04	014-0064-10	040-0166-10	RP	071-0092-39
KWJC-011E-TAC	208/230	3	4.6	27	1.59	3.179					071-0090-50
KWK1-0100-TAC	208/230	3	3.3	25	2.145	4.29					071-0090-04
KWK1-0100-TAD	460	3	1.9	15	6.62	13.24					071-0090-07
KWK2-0100-CAA	115	1	11.4	85.5	0.405	2.248	014-0061-05	014-0064-08	040-0166-11	RP	071-0092-23
KWK2-0100-CAB	230	1	5.4	33.5	2.27	4.935	014-0061-04	014-0064-00	040-0166-10	RP	071-0092-25
KWK2-0100-CAH	208	1	7	36.4	1.885	4.59	014-0061-04	014-0064-00	040-0166-25	RP	071-0092-14
KWK2-0100-CAV	208/230	1	7.3	40	1.37	4.525	014-0061-04	014-0064-10	040-0166-10	RP	071-0092-39
KWKA-010A-TAC	208/230	3	3.3	25	2.145	4.29					071-0090-04
KWKA-011E-TAD	460	3	2.4	15	6.62	13.24					071-0090-42
KWKA-0200-TAC	208/230	3	6.8	50	0.795	1.589					071-0090-35
KWKA-0200-TAD	460	3	3	25	3.165	6.329					071-0090-16
KWKA-020A-TAC	208/230	3	6.8	50	0.795	1.589					071-0090-35
KWKA-020A-TAD	460	3	3	25	3.165	6.329					071-0090-16
KWKA-020E-TAC	208/230	3	6.5	50	0.795	1.589					071-0090-35
KWKB-0150-CAB	230	1	7.5	44	1.65	4.19	014-0036-21	014-0064-11	040-0166-20	RP	071-0092-29
KWKB-0200-CAV	208/230	1	9.1	55	0.94	3.45	014-0036-22	014-0064-19	040-0166-20	RP	071-0099-04
KWKB-020A-CAV	208/230	1	9.1	55	0.94	3.45	014-0036-22	014-0064-19	040-0166-20	RP	071-0099-04
KWKB-021E-CAV	208/230	1	10.6	55	0.94	3.45	014-0036-22	014-0064-14	040-0166-20	RP	071-0099-04
KWL1-0100-TAC	208/230	3	3.3	25	2.145	4.29					071-0090-04

† ‡ § \* See Section F Introduction for more information.

FC31

### Electrical Data - Copelametic - Air Cooled

Model	Volts	PH	Max RLA	LRA	Resistance		Start Cap P/N †	Run Cap P/N ‡	Relay P/N §	Part Type*	Protector P/N
					Run or Line to WYE	Start or Line to Line†					
KWL1-0100-TAD	460	3	1.8	15	6.62	13.24					071-0090-07
KWL2-0100-CAA	115	1	10.9	85.5	0.405	2.248	014-0061-05	014-0064-08	040-0166-11	RP	071-0092-23
KWL2-0100-CAB	230	1	5.5	33.5	2.27	4.935	014-0061-04	014-0064-00	040-0166-10	RP	071-0092-25
KWL2-0100-CAH	208	1	6.8	36.4	1.885	4.59	014-0061-04	014-0064-00	040-0166-25	RP	071-0092-14
KWL2-0100-CAV	208/230	1	6.9	40	1.37	4.525	014-0061-04	014-0064-10	040-0166-10	RP	071-0092-39
KWLA-0100-TAD	460	3	1.8	15	6.62	13.24					071-0090-07
KWLA-010A-TAC	208/230	3	3.3	25	2.145	4.29					071-0090-04
KWLA-010A-TAD	460	3	1.8	15	6.62	13.24					071-0090-07
KWLA-0150-TAC	208/230	3	5.4	35.5	1.325	2.375					071-0090-03
KWLA-0150-TAD	460	3	2.9	18.2	4.72	9.44					071-0090-27
KWLA-0150-TAU	200	3	6.6	48.2	0	1.463					071-0090-28
KWLA-015A-TAC	208/230	3	5.4	35.5	1.325	2.375					071-0090-03
KWLA-015A-TAD	460	3	2.9	18.2	4.72	9.44					071-0090-27
KWLA-016E-TAC	208/230	3	6.6	50	0.795	1.589					071-0090-35
KWLA-016E-TAD	460	3	3.4	25	3.165	6.329					071-0090-16
KWLB-0100-CAV	208/230	1	6.9	40	1.37	4.525	014-0061-04	014-0064-10	040-0166-10	RP	071-0092-39
KWLB-0150-CAB	230	1	5.6	44	1.65	4.19	014-0036-21	014-0064-10	040-0166-20	RP	071-0092-16
KWLB-0150-CAH	208	1	8.1	45	1.32	4.19	014-0036-21	014-0064-10	040-0166-30	RP	071-0092-18
KWLB-0150-CAV	208/230	1	9.9	55	0.94	3.45	014-0036-22	014-0064-19	040-0166-20	RP	071-0099-04
KWLB-015A-CAB	230	1	5.6	44	1.65	4.19	014-0036-21	014-0064-10	040-0166-20	RP	071-0092-16
KWLB-015A-CAV	208/230	1	9.9	55	0.94	3.45	014-0036-22	014-0064-19	040-0166-20	RP	071-0099-04
KWLB-015E-CAV	208/230	1	9.9	55	0.94	3.45	014-0036-22	014-0064-19	040-0166-20	RP	071-0099-04
KWM1-0050-TAC	208/230	3	1.7	13.2	3.34	6.69					071-0090-06

† ‡ § \* See Section F Introduction for more information.

FC32



### Electrical Data - Copelametic - Air Cooled

Model	Volts	PH	Max RLA	LRA	Resistance		Start Cap P/N ‡	Run Cap P/N ‡	Relay P/N §	Part Type*	Protector P/N
					Run or Line to WYE	Start or Line to Line†					
KWM1-0075-TAC	208/230	3	2.7	19.9	2.28	4.551					071-0090-05
KWM1-0100-TAC	208/230	3	4.5	27	1.59	3.179					071-0090-40
KWM1-0100-TAD	460	3	2.2	13.5	6.24	12.48					071-0090-43
KWM2-0050-CAV	208/230	1	3.7	24	2.9	5.785	014-0036-21	014-0064-00	040-0166-09	RP	071-0092-37
KWM2-0050-IAA	115	1	7.2	45	0.835	2.42	014-0061-02		040-0166-08	RP	071-0092-06
KWM2-0050-IAB	230	1	3.8	22.5	3.305	9.585	014-0061-09		040-0166-09	RP	071-0092-05
KWM2-0050-IAH	208	1	3.8	25.5	2.92	7.9	014-0061-09		040-0166-09	RP	071-0092-05
KWM2-0075-CAV	208/230	1	5.6	36	1.9	4.24	014-0061-04	014-0064-00	040-0166-09	RP	071-0092-29
KWM2-0075-IAA	115	1	9.2	59.8	0.59	1.4	014-0061-11		040-0166-08	RP	071-0099-00
KWM2-0075-IAB	230	1	6	30.4	2.34	5.53	014-0061-04		040-0166-09	RP	071-0092-27
KWM2-0075-IAH	208	1	6.1	34.1	2	5.15	014-0061-04		040-0166-09	RP	071-0092-27
KWM2-0100-CAA	115	1	15.5	93	0.376	1.837	014-0061-05	014-0064-08	040-0166-11	RP	071-0099-05
KWM2-0100-CAV	208/230	1	7.5	40	1.37	4.525	014-0061-04	014-0064-10	040-0166-10	RP	071-0092-39
KWMA-0075-TAC	208/230	3	3.2	19.9	2.28	4.551					071-0090-41
KWMA-007E-TAC	208/230	3	3.2	19.9	2.28	4.551					071-0090-41
KWMB-0075-CAA	115	1	10.9	85.5	0.405	2.248	014-0061-05	014-0064-08	040-0166-11	RP	071-0092-40
KWMB-0075-CAV	208/230	1	5.6	36	1.9	4.24	014-0061-04	014-0064-00	040-0166-09	RP	071-0092-29
KWMB-007E-CAA	115	1	10.9	85.5	0.405	2.248	014-0061-05	014-0064-08	040-0166-21	RP	071-0092-40
KWMB-007E-CAV	208/230	1	5.6	36	1.9	4.24	014-0061-04	014-0064-00	040-0166-09	RP	071-0092-29
KWMC-007E-TAC	208/230	3	3.2	19.9	2.28	4.551					071-0090-41
KWN1-0050-TAC	208/230	3	2.1	13.2	3.34	6.69					071-0090-06
KWN1-0075-TAC	208/230	3	3.5	19.9	2.28	4.551					071-0090-41
KWN2-0050-CAV	208/230	1	3.6	24	2.9	5.785	014-0036-21	014-0064-00	040-0166-09	RP	071-0092-37

† ‡ § \* See Section F Introduction for more information.

FC33

### Electrical Data - Copelametic - Air Cooled

Model	Volts	PH	Max RLA	LRA	Resistance		Start Cap P/N ‡	Run Cap P/N ‡	Relay P/N §	Part Type*	Protector P/N
					Run or Line to WYE	Start or Line to Line†					
KWN2-0050-IAA	115	1	8.1	45	0.835	2.42	014-0061-02		040-0166-08	RP	071-0092-06
KWN2-0050-IAB	230	1	4.2	22.5	3.305	9.585	014-0061-09		040-0166-09	RP	071-0092-05
KWN2-0050-IAH	208	1	4.2	25.5	2.92	7.9	014-0061-09		040-0166-09	RP	071-0092-05
KWN2-0075-CAA	115	1	11.7	65	0.519	1.266	014-0061-11	014-0064-06	040-0166-33	RP	071-0099-06
KWN2-0075-CAV	208/230	1	6.1	36	1.9	4.24	014-0061-04	014-0064-00	040-0166-09	RP	071-0092-41
KWNA-006E-TAC	208/230	3	2.2	13.2	3.34	6.69					071-0090-21
KWNA-007E-TAC	208/230	3	3.5	19.9	2.28	4.551					071-0090-41
KWNB-0050-CAV	208/230	1	3.6	24	2.9	5.785	014-0036-21	014-0064-00	040-0166-09	RP	071-0092-37
KWNB-0050-IAA	115	1	8	45	0.835	2.42	014-0061-02		040-0166-08	RP	071-0092-06
KWNB-005A-CAV	208/230	1	3.6	24	2.9	5.785	014-0036-21	014-0064-00	040-0166-09	RP	071-0092-37
KWNB-005E-CAV	208/230	1	3.6	24	2.9	5.785	014-0036-21	014-0064-00	040-0166-09	RP	071-0092-37
KWNB-005E-IAA	115	1	8	45	0.835	2.42	014-0061-02		040-0166-08	RP	071-0092-06
KWNB-007E-CAV	208/230	1	NA	36	1.9	4.24	014-0061-04	014-0064-00	040-0166-09	RP	071-0092-41
KWR1-0100-TAC	208/230	3	4.3	27	1.59	3.179					071-0090-40
KWR1-0100-TAD	460	3	2.2	13.5	6.24	12.48					071-0090-43
KWR2-0100-CAA	115	1	15.4	93	0.376	1.837	014-0061-05	014-0064-08	040-0166-11	RP	071-0099-05
KWR2-0100-CAV	208/230	1	7.4	40	1.37	4.525	014-0061-04	014-0064-10	040-0166-10	RP	071-0092-39
KWRA-010E-TAC	208/230	3	4.3	27	1.59	3.179					071-0090-40
KWRA-011E-TAD	460	3	2	15	6.62	13.24					071-0090-42
KWRA-011L-TAD	460	3	2	15	6.62	13.24					071-0090-42
KWRB-010E-CAV	208/230	1	7.4	40	1.37	4.525	014-0061-04	014-0064-10	040-0166-10	RP	071-0092-39
KWTA-0100-TAC	208/230	3	3.9	25	2.145	4.29					071-0090-04
KWTA-0100-TAD	460	3	2.1	15	6.62	13.24					071-0090-07

† ‡ § \* See Section F Introduction for more information.

FC34

**Electrical Data - Copelametic - Air Cooled**

Model	Volts	PH	Max RLA	LRA	Resistance		Start Cap P/N ‡	Run Cap P/N ‡	Relay P/N §	Part Type*	Protector P/N
					Run or Line to WYE	Start or Line to Line†					
KWTA-010A-TAC	208/230	3	3.9	25	2.145	4.29					071-0090-04
KWTA-010A-TAD	460	3	2.1	15	6.62	13.24					071-0090-07
KWTA-0150-TAC	208/230	3	5	35.5	1.325	2.375					071-0090-03
KWTA-0150-TAD	460	3	2.9	18.2	4.72	9.44					071-0090-27
KWTA-015A-TAC	208/230	3	5	35.5	1.325	2.375					071-0090-03
KWTA-015A-TAD	460	3	2.9	18.2	4.72	9.44					071-0090-27
KWTB-0100-CAA	115	1	12.4	85.5	0.405	2.248	014-0061-05	014-0064-08	040-0166-11	RP	071-0092-23
KWTB-0100-CAB	230	1	5.5	33.5	2.27	4.935	014-0061-04	014-0064-00	040-0166-10	RP	071-0092-25
KWTB-0100-CAH	208	1	7.3	36.4	1.885	4.59	014-0061-04	014-0064-00	040-0166-25	RP	071-0092-14
KWTB-0100-CAV	208/230	1	7.2	40	1.37	4.525	014-0061-04	014-0064-10	040-0166-10	RP	071-0092-39
KWTB-010A-CAH	208	1	7.3	36.4	1.885	4.59	014-0061-04	014-0064-00	040-0166-25	RP	071-0092-14
KWTB-010A-CAV	208/230	1	7.2	40	1.37	4.525	014-0061-04	014-0064-10	040-0166-10	RP	071-0092-39
KWTB-0150-CAB	230	1	6.1	44	1.65	4.19	014-0036-21	014-0064-10	040-0166-20	RP	071-0092-18
KWTB-0150-CAH	208	1	7.8	45	1.32	4.19	014-0036-21	014-0064-10	040-0166-30	RP	071-0092-18
KWTB-0150-CAV	208/230	1	9.6	55	0.94	3.45	014-0036-22	014-0064-19	040-0166-20	RP	071-0099-04
LAC1-0300-TAE	575	3	NA	30	2.7	5.4					071-0090-14
LAC1-0310-CAB	230	1	NA	86	0.61	2.54	014-0006-13	014-0064-14	040-0166-28	RP	071-0119-01
LAC1-0310-TAC	208/230	3	NA	82	0.47	0.9					071-0090-01
LAC1-0310-TAD	460	3	NA	41	1.9	3.6					071-0090-03
LAC1-0310-TAU	200	3	NA	99.7	0	0.056					071-0090-30
LACA-031A-TAC	208/230	3	9.2	82	0.47	0.9					071-0090-01
LACA-032A-TAD	460	3	6	56	1.145	2.29					071-0090-54
LACA-032E-TAC	208/230	3	12.8	112	0.291	0.581					071-0090-47

† ‡ § \* See Section F Introduction for more information.

FC35

### Electrical Data - Copelametic - Air Cooled

Model	Volts	PH	Max RLA	LRA	Resistance		Start Cap P/N ‡	Run Cap P/N ‡	Relay P/N §	Part Type*	Protector P/N
					Run or Line to WYE	Start or Line to Line†					
LACA-032E-TAD	460	3	6	56	1.145	2.29					071-0090-54
LACA-032L-TAC	208/230	3	12.8	112	0.291	0.581					071-0090-47
LACA-032L-TAD	460	3	6	56	1.145	2.29					071-0090-54
LACB-031A-CAB	230	1	15.4	86	0.61	2.54	014-0006-13	014-0064-14	040-0166-28	RP	071-0119-01
LACB-032E-CAB	230	1	15.5	105	0.472	1.36	014-0006-13	014-0064-18	040-0166-28	RP	071-0119-05
LACB-032L-CAB	230	1	15.5	105	0.472	1.36	014-0006-13	014-0064-18	040-0166-28	RP	071-0119-05
LAH1-0300-TAE	575	3	4	30	2.7	5.4					071-0090-14
LAH1-0310-CAB	230	1	15.1	86	0.61	2.54	014-0006-13	014-0064-12	040-0166-28	RP	071-0119-01
LAH1-0310-TA7	380	3	6.9	46	0	2.76					071-0090-33
LAH1-0310-TAC	208/230	3	9.9	82	0.47	0.9					071-0090-19
LAH1-0310-TAD	460	3	5.7	41	1.9	3.6					071-0090-03
LAHA-0310-TAC	208/230	3	9.9	82	0.47	0.9					071-0090-19
LAHA-0310-TAD	460	3	NA	41	1.675	3.35					071-0090-03
LAHA-031A-TAC	208/230	3	8.5	82	0.444	0.943					071-0090-19
LAHA-031A-TAD	460	3	5.1	41	1.675	3.35					071-0090-03
LAHA-031E-TAC	208/230	3	8.5	82	0.444	0.943					071-0090-19
LAHA-031L-TAC	208/230	3	8.5	82	0.444	0.943					071-0090-19
LAHA-031L-TAD	460	3	5.1	41	1.675	3.35					071-0090-03
LAHA-0320-TA7	380	3	6.1	56	1.145	2.29					071-0090-46
LAHA-0320-TAC	208/230	3	12.8	112	0.291	0.581					071-0090-47
LAHA-0320-TAU	200	3	12.8	112	0.291	0.581					071-0090-47
LAHA-032A-TAE	575	3	4.1	30	2.7	5.4					071-0090-14
LAHA-032E-TAC	208/230	3	12.8	112	0.291	0.581					071-0090-47

† ‡ § \* See Section F Introduction for more information.

FC36

**Electrical Data - Copelametic - Air Cooled**

Model	Volts	PH	Max RLA	LRA	Resistance		Start Cap P/N ‡	Run Cap P/N ‡	Relay P/N §	Part Type*	Protector P/N
					Run or Line to WYE	Start or Line to Line†					
LAHA-032E-TAD	460	3	6	56	1.145	2.29					071-0090-54
LAHA-032E-TAE	575	3	4.1	30	2.7	5.4					071-0090-14
LAHA-032L-TAC	208/230	3	12.8	112	0.291	0.581					071-0090-47
LAHA-032L-TAD	460	3	6	56	1.145	2.29					071-0090-54
LAHA-032L-TAE	575	3	4.1	30	2.7	5.4					071-0090-14
LAHB-0311-CAB	230	1	16.6	93	0.574	1.899	014-0006-13	014-0064-14	040-0166-28	RP	071-0119-05
LAHB-031A-CAB	230	1	16.6	93	0.574	1.899	014-0006-13	014-0064-14	040-0166-28	RP	071-0119-05
LAHB-031E-CAB	230	1	16.6	93	0.574	1.899	014-0006-13	014-0064-14	040-0166-28	RP	071-0119-05
LAHB-031L-CAB	230	1	16.6	93	0.574	1.899	014-0006-13	014-0064-14	040-0166-28	RP	071-0119-05
LAHB-032E-CAB	230	1	16.7	105	0.472	1.36	014-0006-13	014-0064-18	040-0166-28	RP	071-0119-05
LAHB-032L-CAB	230	1	16.7	105	0.472	1.36	014-0006-13	014-0064-18	040-0166-28	RP	071-0119-05
LAL1-0300-TAE	575	3	NA	30	2.7	5.4					071-0090-14
LAL1-0310-CAB	230	1	NA	86	0.61	2.54	014-0006-13	014-0064-14	040-0166-28	RP	071-0119-01
LAL1-0310-TAC	208/230	3	NA	82	0.47	0.9					071-0090-18
LAL1-0310-TAD	460	3	NA	41	1.9	3.6					071-0090-03
LAL1-031L-TAC	208/230	3	10.9	82	0.47	0.9					071-0090-18
LAL1-031L-TAD	460	3	5	41	1.9	3.6					071-0090-03
LALA-031A-TAC	208/230	3	10.9	82	0.47	0.9					071-0090-18
LALA-032E-FXX	55	3	NA	320	0	0.12					
LALA-032E-TAC	208/230	3	12.6	112	0.291	0.581					071-0090-47
LALA-032E-TAD	460	3	6.2	56	1.145	2.29					071-0090-46
LALA-032L-TAC	208/230	3	12.6	112	0.291	0.581					071-0090-47
LALA-032L-TAD	460	3	6.2	56	1.145	2.29					071-0090-46

† ‡ § \* See Section F Introduction for more information.

FC37

**Electrical Data - Copelametic - Air Cooled**

Model	Volts	PH	Max RLA	LRA	Resistance		Start Cap P/N †	Run Cap P/N †	Relay P/N §	Part Type*	Protector P/N
					Run or Line to WYE	Start or Line to Line†					
LALB-031A-CAB	230	1	14.2	86	0.61	2.54	014-0006-13	014-0064-14	040-0166-28	RP	071-0119-01
LALB-032E-CAB	230	1	15	105	0.472	1.36	014-0006-13	014-0064-18	040-0166-28	RP	071-0119-05
LALB-032L-CAB	230	1	15	105	0.472	1.36	014-0006-13	014-0064-18	040-0166-28	RP	071-0119-05
LAM1-0300-TAE	575	3	4	30	2.7	5.4					071-0090-13
LAM1-0310-CAB	230	1	12.7	86	0.61	2.54	014-0006-13	014-0064-12	040-0166-28	RP	071-0119-01
LAM1-0310-TAC	208/230	3	10	82	0.47	0.9					071-0090-01
LAM1-0310-TAD	460	3	4.7	41	1.9	3.6					071-0090-03
LAMA-031A-TAC	208/230	3	10	82	0.47	0.9					071-0090-01
LAMA-031A-TAD	460	3	4.7	41	1.9	3.6					071-0090-03
LAMB-031A-CAB	230	1	12.7	86	0.61	2.54	014-0006-13	014-0064-12	040-0166-28	RP	071-0119-01

† ‡ § \* See Section F Introduction for more information.

FC38

### Electrical Data - Copelametic Small Refrigerant-Cooled Compressors

Model	Volts	PH	Max RLA	LRA	Resistance		Start Cap P/N	Run Cap P/N	Relay P/N	Part Type*	Protector P/N
					Start or Line to Line	Run or Line to WYE					
2DA3-060E-TFE	575	3	9.1	49	3.714	0					071-0429-18
2DA3F23K0-TFC	208/230	3	28.8	161	0.419	0					071-0429-08
2DA3F23K0-TFD	460	3	9.7	60	2.382	0					071-0429-10
2DA3F23K0-TFE	575	3	9.1	49	3.714	0					071-0429-18
2DA3F23KE-TFC	208/230	3	28.8	161	0.419	0					071-0429-08
2DA3F23KE-TFD	460	3	9.7	60	2.382	0					071-0429-10
2DA3F23KE-TFE	575	3	9.1	49	3.714	0					071-0429-18
2DA3F23KL-TFC	208/230	3	28.8	161	0.419	0					071-0429-08
2DA3F23KL-TFD	460	3	9.7	60	2.382	0					071-0429-10
2DA3F23KL-TFE	575	3	9.1	49	3.714	0					071-0429-18
2DA3R58K0-TFC	208/230	3	22.3	120	0.595	0					071-0429-02
2DA3R58K0-TFD	460	3	10.4	60	2.382	0					071-0429-10
2DA3R89K0-TFC	208/230	3	32	169	0.386	0					071-0429-08
2DA3R89K0-TFD	460	3	14.1	85	1.508	0					071-0429-05
2DA3R89K0-TFE	575	3	13.3	67	2.518	0					071-0429-25
2DA3R89KE-TFC	208/230	3	32	169	0.386	0					071-0429-08
2DA3R89KE-TFD	460	3	14.1	85	1.508	0					071-0429-05
2DA3R89KE-TFE	575	3	13.3	67	2.518	0					071-0429-25
2DA3R89KL-TFC	208/230	3	32	169	0.386	0					071-0429-08
2DA3R89KL-TFD	460	3	14.1	85	1.508	0					071-0429-05
2DA3R89KL-TFE	575	3	13.3	67	2.518	0					071-0429-25
2DA8F23KE-TFD	460	3	9.7	60	2.382	0					071-0429-10
2DB3F25K0-TFC	208/230	3	28.2	161	0.419	0					071-0429-08

\* See Section F Introduction for more information.

FD1

### Electrical Data - Copelametic Small Refrigerant-Cooled Compressors

Model	Volts	PH	Max RLA	LRA	Resistance		Start Cap P/N	Run Cap P/N	Relay P/N	Part Type*	Protector P/N
					Start or Line to Line	Run or Line to WYE					
2DB3F25K0-TFD	460	3	13.3	80	1.674	0					071-0429-05
2DB3F25K0-TFE	575	3	9.6	63	2.614	0					071-0429-26
2DB3F25KE-TFC	208/230	3	28.2	161	0.419	0					071-0429-08
2DB3F25KE-TFD	460	3	13.3	80	1.674	0					071-0429-05
2DB3F25KE-TFE	575	3	9.6	63	2.614	0					071-0429-26
2DB3F25KL-TFC	208/230	3	28.2	161	0.419	0					071-0429-08
2DB3F25KL-TFD	460	3	13.3	80	1.674	0					071-0429-05
2DB3F25KL-TFE	575	3	9.6	63	2.614	0					071-0429-26
2DB3R61K0-TFC	208/230	3	19.1	120	0.595	0					071-0429-02
2DB3R61K0-TFD	460	3	10.2	60	2.382	0					071-0429-10
2DB8F25KE-TFD	460	3	13.3	80	1.674	0					071-0429-05
2DC3-0500-TFD	460	3	10.4	60	2.382	0					071-0429-10
2DC3-050E-TFC	208/230	3	22.3	120	0.595	0					071-0429-13
2DC3-050E-TFD	460	3	10.4	60	2.382	0					071-0429-10
2DC3R53K0-CFB	230	1	30.2	125	1.4	0.37	014-0006-14	014-0064-18	040-0166-23	RP	071-0476-01
2DC3R53K0-TFC	208/230	3	22.3	120	0.595	0					071-0429-13
2DC3R53K0-TFD	460	3	10.4	60	2.382	0					071-0429-10
2DC3R53K0-TFE	575	3	7.7	49	3.714	0					071-0429-23
2DC3R53KE-TFC	208/230	3	22.3	120	0.595	0					071-0429-13
2DC3R53KE-TFD	460	3	10.4	60	2.382	0					071-0429-10
2DC3R53KE-TFE	575	3	7.7	49	3.714	0					071-0429-23
2DC3R53KL-CFB	230	1	30.2	125	1.4	0.37	014-0006-14	014-0064-18	040-0166-23	RP	071-0476-01
2DC3R53KL-TFC	208/230	3	22.3	120	0.595	0					071-0429-13

FD2 \* See Section F Introduction for more information.



### Electrical Data - Copelametic Small Refrigerant-Cooled Compressors

Model	Volts	PH	Max RLA	LRA	Resistance		Start Cap P/N	Run Cap P/N	Relay P/N	Part Type*	Protector P/N
					Start or Line to Line	Run or Line to WYE					
2DC3R53KL-TFD	460	3	10.4	60	2.382	0					071-0429-10
2DC3R53KL-TFE	575	3	7.7	49	3.714	0					071-0429-23
2DCJR53K0-TFC	208/230	3	22.3	120	0.595	0					071-0429-13
2DD3-050E-TFD	460	3	10.5	60	2.382	0					071-0429-10
2DD3R63K0-TFC	208/230	3	22.3	120	0.595	0					071-0429-24
2DD3R63K0-TFD	460	3	10.5	60	2.382	0					071-0429-10
2DD3R63K0-TFE	575	3	7.9	49	3.714	0					071-0429-23
2DD3R63KE-TFC	208/230	3	22.3	120	0.595	0					071-0429-24
2DD3R63KE-TFD	460	3	10.5	60	2.382	0					071-0429-10
2DD3R63KE-TFE	575	3	7.9	49	3.714	0					071-0429-23
2DD3R63KL-TFC	208/230	3	22.3	120	0.595	0					071-0429-24
2DD3R63KL-TFD	460	3	10.5	60	2.382	0					071-0429-10
2DD3R63KL-TFE	575	3	7.9	49	3.714	0					071-0429-23
2DD8R63K0-TFC	208/230	3	22.3	120	0.595	0					071-0429-24
2DF3-0300-CFB	230	1	25.7	125	1.4	0.37	014-0006-14	014-0064-18	040-0166-23	RP	071-0476-01
2DF3-0300-TFC	208/230	3	16.9	102	0.67	0					071-0429-22
2DF3-030E-CFB	230	1	25.7	125	1.4	0.37	014-0006-14	014-0064-18	040-0166-23	RP	071-0476-01
2DF3-030E-TFC	208/230	3	16.9	102	0.67	0					071-0429-22
2DF3F16K0-CFB	230	1	25.7	125	1.4	0.37	014-0006-14	014-0064-18	040-0166-23	RP	071-0476-01
2DF3F16K0-TFC	208/230	3	16.9	102	0.67	0					071-0429-22
2DF3F16K0-TFD	460	3	8.1	52	2.68	0					071-0429-23
2DF3F16K0-TFE	575	3	6.7	41	4.406	0					071-0429-27
2DF3F16KE-CFB	230	1	25.7	125	1.4	0.37	014-0006-14	014-0064-18	040-0166-23	RP	071-0476-01

\* See Section F Introduction for more information.

FD3

### Electrical Data - Copelametic Small Refrigerant-Cooled Compressors

Model	Volts	PH	Max RLA	LRA	Resistance		Start Cap P/N	Run Cap P/N	Relay P/N	Part Type*	Protector P/N
					Start or Line to Line	Run or Line to WYE					
2DF3F16KE-TFC	208/230	3	16.9	102	0.67	0					071-0429-22
2DF3F16KE-TFD	460	3	8.1	52	2.68	0					071-0429-23
2DF3F16KE-TFE	575	3	6.7	41	4.406	0					071-0429-27
2DF3F16KL-TFC	208/230	3	16.9	102	0.67	0					071-0429-22
2DF3F16KL-TFD	460	3	8.1	52	2.68	0					071-0429-23
2DF3F16KL-TFE	575	3	6.7	41	4.406	0					071-0429-27
2DL3-075E-TFC	208/230	3	31.6	169	0.386	0					071-0429-08
2DL3F20K0-TFC	208/230	3	26.3	161	0.419	0					071-0429-08
2DL3F20K0-TFD	460	3	8.7	60	2.382	0					071-0429-10
2DL3F20K0-TFE	575	3	7.7	49	3.714	0					071-0429-23
2DL3F20KE-TFC	208/230	3	26.3	161	0.419	0					071-0429-08
2DL3F20KE-TFD	460	3	8.7	60	2.382	0					071-0429-10
2DL3F20KE-TFE	575	3	7.7	49	3.714	0					071-0429-23
2DL3F20KL-TFC	208/230	3	26.3	161	0.419	0					071-0429-08
2DL3F20KL-TFD	460	3	8.7	60	2.382	0					071-0429-10
2DL3F20KL-TFE	575	3	7.7	49	3.714	0					071-0429-23
2DL3R78K0-TFC	208/230	3	31.6	169	0.386	0					071-0429-08
2DL3R78K0-TFD	460	3	13.9	85	1.508	0					071-0429-05
2DL3R78K0-TFE	575	3	13.2	67	2.518	0					071-0429-25
2DL3R78KE-TFC	208/230	3	31.6	169	0.386	0					071-0429-08
2DL3R78KE-TFD	460	3	13.9	85	1.508	0					071-0429-05
2DL3R78KE-TFE	575	3	13.2	67	2.518	0					071-0429-25
2DL3R78KL-TFC	208/230	3	31.6	169	0.386	0					071-0429-08

FD4 \* See Section F Introduction for more information.

### Electrical Data - Copelametic Small Refrigerant-Cooled Compressors

Model	Volts	PH	Max RLA	LRA	Resistance		Start Cap P/N	Run Cap P/N	Relay P/N	Part Type*	Protector P/N
					Start or Line to Line	Run or Line to WYE					
2DL3R78KL-TFD	460	3	13.9	85	1.508	0					071-0429-05
2DL3R78KL-TFE	575	3	13.2	67	2.518	0					071-0429-25
3DA3A0500-TFC	208/230	3	18.6	115	0.603	0					071-0429-02
3DA3A0500-TFD	460	3	9.1	58	2.412	0					071-0429-03
3DA3A0500-TFE	575	3	7.9	43	3.794	0					071-0429-19
3DA3A0600-TFC	208/230	3	30.3	150	0.419	0					071-0429-08
3DA3A0600-TFD	460	3	13.7	77	1.676	0					071-0429-05
3DA3A0600-TFE	575	3	10.5	62	2.6	0					071-0429-03
3DA3A060E-TFC	208/230	3	30.3	150	0.419	0					071-0429-08
3DA3A060E-TFD	460	3	13.7	77	1.676	0					071-0429-05
3DA3A060E-TFE	575	3	10.5	62	2.6	0					071-0429-03
3DA3A060L-TFC	208/230	3	30.3	150	0.419	0					071-0429-08
3DA3A060L-TFD	460	3	13.7	77	1.676	0					071-0429-05
3DA3A060L-TFE	575	3	10.5	62	2.6	0					071-0429-03
3DA3A0750-TFC	208/230	3	41	215	0.295	0					071-0429-06
3DA3A0750-TFD	460	3	20	106	1.178	0					071-0429-17
3DA3A0750-TFE	575	3	16.4	84	1.835	0					071-0429-11
3DA3A0750-TFU	200	3	34.9	196	0.294	0					071-0429-04
3DA3A075E-TFC	208/230	3	41	215	0.295	0					071-0429-06
3DA3A075E-TFD	460	3	20	106	1.178	0					071-0429-17
3DA3A075E-TFE	575	3	16.4	84	1.835	0					071-0429-11
3DA3A075L-TFC	208/230	3	41	215	0.295	0					071-0429-06
3DA3A075L-TFD	460	3	20	106	1.178	0					071-0429-17

\* See Section F Introduction for more information.

FD5

### Electrical Data - Copelametic Small Refrigerant-Cooled Compressors

Model	Volts	PH	Max RLA	LRA	Resistance		Start Cap P/N	Run Cap P/N	Relay P/N	Part Type*	Protector P/N
					Start or Line to Line	Run or Line to WYE					
3DA3A075L-TFE	575	3	16.4	84	1.835	0					071-0429-11
3DA3F18K0-TFC	208/230	3	18.6	115	0.603	0					071-0429-02
3DA3F18K0-TFD	460	3	9.1	58	2.412	0					071-0429-03
3DA3F28K0-TFC	208/230	3	30.3	150	0.419	0					071-0429-08
3DA3F28K0-TFD	460	3	13.7	77	1.676	0					071-0429-05
3DA3F28K0-TFE	575	3	10.5	62	2.6	0					071-0429-03
3DA3F28KE-TFC	208/230	3	30.3	150	0.419	0					071-0429-08
3DA3F28KE-TFD	460	3	13.7	77	1.676	0					071-0429-05
3DA3F28KE-TFE	575	3	10.5	62	2.6	0					071-0429-03
3DA3F28KL-TFC	208/230	3	30.3	150	0.419	0					071-0429-08
3DA3F28KL-TFD	460	3	13.7	77	1.676	0					071-0429-05
3DA3F28KL-TFE	575	3	10.5	62	2.6	0					071-0429-03
3DA3R10M0-TFC	208/230	3	41	215	0.295	0					071-0429-06
3DA3R10M0-TFD	460	3	20	106	1.178	0					071-0429-17
3DA3R10M0-TFE	575	3	16.4	84	1.835	0					071-0429-11
3DA3R10M0-TFU	200	3	34.9	196	0.294	0					071-0429-04
3DA3R10ME-TFC	208/230	3	41	215	0.295	0					071-0429-06
3DA3R10ME-TFD	460	3	20	106	1.178	0					071-0429-17
3DA3R10ME-TFE	575	3	16.4	84	1.835	0					071-0429-11
3DA3R10ML-TFC	208/230	3	41	215	0.295	0					071-0429-06
3DA3R10ML-TFD	460	3	20	106	1.178	0					071-0429-17
3DA3R10ML-TFE	575	3	16.4	84	1.835	0					071-0429-11
3DA8A0500-TFD	460	3	9.1	58	2.412	0					071-0429-03

FD6 \* See Section F Introduction for more information.

### Electrical Data - Copelametic Small Refrigerant-Cooled Compressors

Model	Volts	PH	Max RLA	LRA	Resistance		Start Cap P/N	Run Cap P/N	Relay P/N	Part Type*	Protector P/N
					Start or Line to Line	Run or Line to WYE					
3DA8A0501-TFD	460	3	9.1	58	2.412	0					071-0429-03
3DA8A051E-TFD	460	3	9.1	58	2.412	0					071-0429-03
3DA8A060E-TFD	460	3	13.7	77	1.676	0					071-0429-05
3DA8F28KE-TFD	460	3	13.7	77	1.676	0					071-0429-05
3DB3A0500-TFC	208/230	3	18	115	0.603	0					071-0429-02
3DB3A0500-TFD	460	3	10.1	58	2.412	0					071-0429-03
3DB3A0500-TFE	575	3	7.5	43	3.794	0					071-0429-19
3DB3A0750-TFC	208/230	3	31.4	161	0.385	0					071-0429-04
3DB3A0750-TFD	460	3	16.1	83	1.54	0					071-0429-09
3DB3A0750-TFE	575	3	11	67	2.508	0					071-0429-03
3DB3A075E-TFC	208/230	3	31.4	161	0.385	0					071-0429-04
3DB3A075E-TFD	460	3	16.1	83	1.54	0					071-0429-09
3DB3A075E-TFE	575	3	11	67	2.508	0					071-0429-03
3DB3A075L-TFC	208/230	3	31.4	161	0.385	0					071-0429-04
3DB3A075L-TFD	460	3	16.1	83	1.54	0					071-0429-09
3DB3A075L-TFE	575	3	11	67	2.508	0					071-0429-03
3DB3A0900-TFU	200	3	36.8	196	0.294	0					071-0429-20
3DB3A1000-TFC	208/230	3	43.6	215	0.295	0					071-0429-06
3DB3A1000-TFD	460	3	20	106	1.178	0					071-0429-17
3DB3A1000-TFE	575	3	16.5	84	1.835	0					071-0429-11
3DB3A100E-TFC	208/230	3	43.6	215	0.295	0					071-0429-06
3DB3A100E-TFD	460	3	20	106	1.178	0					071-0429-17
3DB3A100E-TFE	575	3	16.5	84	1.835	0					071-0429-11

\* See Section F Introduction for more information.

FD7

### Electrical Data - Copelametic Small Refrigerant-Cooled Compressors

Model	Volts	PH	Max RLA	LRA	Resistance		Start Cap P/N	Run Cap P/N	Relay P/N	Part Type*	Protector P/N
					Start or Line to Line	Run or Line to WYE					
3DB3A100L-TFC	208/230	3	43.6	215	0.295	0					071-0429-06
3DB3A100L-TFD	460	3	20	106	1.178	0					071-0429-17
3DB3A100L-TFE	575	3	16.5	84	1.835	0					071-0429-11
3DB3F22K0-TFC	208/230	3	18	115	0.603	0					071-0429-02
3DB3F22K0-TFD	460	3	10.1	58	2.412	0					071-0429-03
3DB3F27K0-TFU	200	3	36.8	196	0.294	0					071-0429-20
3DB3F33K0-TFC	208/230	3	31.4	161	0.385	0					071-0429-04
3DB3F33K0-TFD	460	3	16.1	83	1.54	0					071-0429-09
3DB3F33K0-TFE	575	3	11	67	2.508	0					071-0429-03
3DB3F33KE-TFC	208/230	3	31.4	161	0.385	0					071-0429-04
3DB3F33KE-TFD	460	3	16.1	83	1.54	0					071-0429-09
3DB3F33KE-TFE	575	3	11	67	2.508	0					071-0429-03
3DB3F33KL-TFC	208/230	3	31.4	161	0.385	0					071-0429-04
3DB3F33KL-TFD	460	3	16.1	83	1.54	0					071-0429-09
3DB3F33KL-TFE	575	3	11	67	2.508	0					071-0429-03
3DB3R12M0-TFC	208/230	3	43.6	215	0.295	0					071-0429-06
3DB3R12M0-TFD	460	3	20	106	1.178	0					071-0429-17
3DB3R12M0-TFE	575	3	16.5	84	1.835	0					071-0429-11
3DB3R12ME-TFC	208/230	3	43.6	215	0.295	0					071-0429-06
3DB3R12ME-TFD	460	3	20	106	1.178	0					071-0429-17
3DB3R12ME-TFE	575	3	16.5	84	1.835	0					071-0429-11
3DB3R12ML-TFC	208/230	3	43.6	215	0.295	0					071-0429-06
3DB3R12ML-TFD	460	3	20	106	1.178	0					071-0429-17

FD8 \* See Section F Introduction for more information.

### Electrical Data - Copelametic Small Refrigerant-Cooled Compressors

Model	Volts	PH	Max RLA	LRA	Resistance		Start Cap P/N	Run Cap P/N	Relay P/N	Part Type*	Protector P/N
					Start or Line to Line	Run or Line to WYE					
3DB3R12ML-TFE	575	3	16.5	84	1.835	0					071-0429-11
3DB4A1000-TFC	208/230	3	43.6	215	0.295	0					071-0429-06
3DB4A1000-TFD	460	3	20	106	1.178	0					071-0429-17
3DB4R12M0-TFC	208/230	3	43.6	215	0.295	0					071-0429-06
3DB8A075E-TFD	460	3	16.1	83	1.54	0					071-0429-09
3DB8F33KE-TFD	460	3	16.1	83	1.54	0					071-0429-09
3DE3A0500-TFC	208/230	3	18.6	115	0.603	0					071-0429-02
3DE3A0500-TFD	460	3	11	58	2.412	0					071-0429-03
3DE3A0500-TFE	575	3	7.9	43	3.794	0					071-0429-19
3DE3A0750-TFC	208/230	3	41	215	0.295	0					071-0429-06
3DE3A0750-TFD	460	3	20	106	1.178	0					071-0429-17
3DE3A0750-TFE	575	3	16.4	84	1.835	0					071-0429-11
3DE3A0750-TFU	200	3	34.9	196	0.294	0					071-0429-04
3DE3A075E-TFC	208/230	3	41	215	0.295	0					071-0429-06
3DE3A075E-TFD	460	3	20	106	1.178	0					071-0429-17
3DE3A075E-TFE	575	3	16.4	84	1.835	0					071-0429-11
3DE3A075L-TFC	208/230	3	41	215	0.295	0					071-0429-06
3DE3A075L-TFD	460	3	20	106	1.178	0					071-0429-17
3DE3A075L-TFE	575	3	16.4	84	1.835	0					071-0429-11
3DE3R10M0-TFC	208/230	3	41	215	0.295	0					071-0429-06
3DE3R10M0-TFD	460	3	20	106	1.178	0					071-0429-17
3DE3R10M0-TFE	575	3	16.4	84	1.835	0					071-0429-11
3DE3R10ME-TFC	208/230	3	41	215	0.295	0					071-0429-06

\* See Section F Introduction for more information.

FD9

### Electrical Data - Copelametic Small Refrigerant-Cooled Compressors

Model	Volts	PH	Max RLA	LRA	Resistance		Start Cap P/N	Run Cap P/N	Relay P/N	Part Type*	Protector P/N
					Start or Line to Line	Run or Line to WYE					
3DE3R10ME-TFD	460	3	20	106	1.178	0					071-0429-17
3DE3R10ME-TFE	575	3	16.4	84	1.835	0					071-0429-11
3DE3R10ML-TFC	208/230	3	41	215	0.295	0					071-0429-06
3DE3R10ML-TFD	460	3	20	106	1.178	0					071-0429-17
3DE3R10ML-TFE	575	3	16.4	84	1.835	0					071-0429-11
3DE8A0500-TFC	208/230	3	18.6	115	0.603	0					071-0429-02
3DE8A0500-TFD	460	3	11	58	2.412	0					071-0429-03
3DE8A060E-TFD	460	3	13.7	77	1.676	0					071-0429-05
3DE8A0750-TFD	460	3	20	106	1.178	0					071-0429-17
3DEHA075E-TFC	208/230	3	41	215	0.295	0					071-0429-06
3DEHA075E-TFD	460	3	20	106	1.178	0					071-0429-17
3DEHA075E-TFE	575	3	16.4	84	1.835	0					071-0429-11
3DEHA075L-TFC	208/230	3	41	215	0.295	0					071-0429-06
3DEHA075L-TFD	460	3	20	106	1.178	0					071-0429-17
3DEHA075L-TFE	575	3	16.4	84	1.835	0					071-0429-11
3DEHR10ME-TFC	208/230	3	41	215	0.295	0					071-0429-06
3DEHR10ME-TFD	460	3	20	106	1.178	0					071-0429-17
3DEHR10ME-TFE	575	3	16.4	84	1.835	0					071-0429-11
3DEHR10ML-TFC	208/230	3	41	215	0.295	0					071-0429-06
3DEHR10ML-TFD	460	3	20	106	1.178	0					071-0429-17
3DEHR10ML-TFE	575	3	16.4	84	1.835	0					071-0429-11
3DETA050E-TFD	460	3	11	58	2.412	0					071-0429-03
3DETR70KE-TFD	460	3	11	58	2.412	0					071-0429-03

FD10 \* See Section F Introduction for more information.



### Electrical Data - Copelametic Small Refrigerant-Cooled Compressors

Model	Volts	PH	Max RLA	LRA	Resistance		Start Cap P/N	Run Cap P/N	Relay P/N	Part Type*	Protector P/N
					Start or Line to Line	Run or Line to WYE					
3DF3A0750-TFC	208/230	3	30.7	161	0.385	0					071-0429-04
3DF3A0750-TFD	460	3	15	83	1.54	0					071-0429-09
3DF3A0900-TFC	208/230	3	39	215	0.295	0					071-0429-00
3DF3A0900-TFD	460	3	16.9	106	1.178	0					071-0429-09
3DF3A0900-TFE	575	3	16.4	84	1.835	0					071-0429-11
3DF3A090E-TFC	208/230	3	39	215	0.295	0					071-0429-00
3DF3A090E-TFD	460	3	16.9	106	1.178	0					071-0429-09
3DF3A090E-TFE	575	3	16.4	84	1.835	0					071-0429-11
3DF3A090L-TFC	208/230	3	39	215	0.295	0					071-0429-00
3DF3A090L-TFD	460	3	16.9	106	1.178	0					071-0429-09
3DF3A090L-TFE	575	3	16.4	84	1.835	0					071-0429-11
3DF3A1200-TFC	208/230	3	48.1	275	0.229	0					071-0504-05
3DF3A1200-TFD	460	3	23.6	138	0.908	0					071-0504-02
3DF3A120E-TFC	208/230	3	48.1	275	0.229	0					071-0504-05
3DF3A120E-TFD	460	3	23.6	138	0.908	0					071-0504-02
3DF3A120L-TFC	208/230	3	48.1	275	0.229	0					071-0504-05
3DF3A120L-TFD	460	3	23.6	138	0.908	0					071-0504-02
3DF3F26K0-TFC	208/230	3	30.7	161	0.385	0					071-0429-04
3DF3F26K0-TFD	460	3	15	83	1.54	0					071-0429-09
3DF3F40K0-TFC	208/230	3	39	215	0.295	0					071-0429-00
3DF3F40K0-TFD	460	3	16.9	106	1.178	0					071-0429-09
3DF3F40K0-TFE	575	3	16.4	84	1.835	0					071-0429-11
3DF3F40KE-TFC	208/230	3	39	215	0.295	0					071-0429-00

\* See Section F Introduction for more information.

FD11

### Electrical Data - Copelametic Small Refrigerant-Cooled Compressors

Model	Volts	PH	Max RLA	LRA	Resistance		Start Cap P/N	Run Cap P/N	Relay P/N	Part Type*	Protector P/N
					Start or Line to Line	Run or Line to WYE					
3DF3F40KE-TFD	460	3	16.9	106	1.178	0					071-0429-09
3DF3F40KE-TFE	575	3	16.4	84	1.835	0					071-0429-11
3DF3F40KL-TFC	208/230	3	39	215	0.295	0					071-0429-00
3DF3F40KL-TFD	460	3	16.9	106	1.178	0					071-0429-09
3DF3F40KL-TFE	575	3	16.4	84	1.835	0					071-0429-11
3DF3R15M0-TFC	208/230	3	48.1	275	0.229	0					071-0504-05
3DF3R15M0-TFD	460	3	23.6	138	0.908	0					071-0504-02
3DF3R15ME-TFC	208/230	3	48.1	275	0.229	0					071-0504-05
3DF3R15ME-TFD	460	3	23.6	138	0.908	0					071-0504-02
3DF3R15ML-TFC	208/230	3	48.1	275	0.229	0					071-0504-05
3DF3R15ML-TFD	460	3	23.6	138	0.908	0					071-0504-02
3DF4A0900-TFC	208/230	3	39	215	0.295	0					071-0429-00
3DF4A0900-TFD	460	3	16.9	106	1.178	0					071-0429-09
3DF4A1200-TFC	208/230	3	48.1	275	0.229	0					071-0504-05
3DF4A1200-TFD	460	3	23.6	138	0.908	0					071-0504-02
3DF4A120E-TFC	208/230	3	48.1	275	0.229	0					071-0504-05
3DF4A120E-TFD	460	3	23.6	138	0.908	0					071-0504-02
3DF4A120L-TFC	208/230	3	48.1	275	0.229	0					071-0504-05
3DF4A120L-TFD	460	3	23.6	138	0.908	0					071-0504-02
3DF4R15M0-TFC	208/230	3	48.1	275	0.229	0					071-0504-05
3DF4R15ME-TFC	208/230	3	48.1	275	0.229	0					071-0504-05
3DF4R15ME-TFD	460	3	23.6	138	0.908	0					071-0504-02
3DF4R15ML-TFC	208/230	3	48.1	275	0.229	0					071-0504-05

FD12 \* See Section F Introduction for more information.

### Electrical Data - Copelametic Small Refrigerant-Cooled Compressors

Model	Volts	PH	Max RLA	LRA	Resistance		Start Cap P/N	Run Cap P/N	Relay P/N	Part Type*	Protector P/N
					Start or Line to Line	Run or Line to WYE					
3DF4R15ML-TFD	460	3	23.6	138	0.908	0					071-0504-02
3DF4S11M0-TFC	208/230	3	38.6	240	0.255	0					071-0429-35
3DF4S11M0-TFD	460	3	18.6	115	1.02	0					071-0429-33
3DF4S11ME-TFC	208/230	3	42.6	240	0.255	0					071-0429-35
3DF4S11ME-TFD	460	3	20.4	115	1.02	0					071-0429-33
3DF4S11ML-TFC	208/230	3	42.6	240	0.255	0					071-0429-35
3DF4S11ML-TFD	460	3	20.4	115	1.02	0					071-0429-33
3DF8A0750-TFC	208/230	3	30.7	161	0.385	0					071-0429-04
3DF8A0750-TFD	460	3	15	83	1.54	0					071-0429-09
3DF8A0751-TFD	460	3	15	83	1.54	0					071-0429-09
3DF8A075E-TFC	208/230	3	30.7	161	0.385	0					071-0429-04
3DF8A076E-TFD	460	3	15	83	1.54	0					071-0429-09
3DF8R98KE-TFC	208/230	3	30.7	161	0.385	0					071-0429-04
3DFTA075E-TFD	460	3	15	83	1.54	0					071-0429-09
3DG3A0900-TFC	208/230	3	35.7	215	0.295	0					071-0429-00
3DG3A0900-TFD	460	3	15.6	106	1.178	0					071-0429-09
3DG3A0900-TFE	575	3	15.7	84	1.835	0					071-0429-11
3DG3A090E-TFC	208/230	3	35.7	215	0.295	0					071-0429-00
3DG3A090E-TFD	460	3	15.6	106	1.178	0					071-0429-09
3DG3A090E-TFE	575	3	15.7	84	1.835	0					071-0429-11
3DG3A090L-TFC	208/230	3	35.7	215	0.295	0					071-0429-00
3DG3A090L-TFD	460	3	15.6	106	1.178	0					071-0429-09
3DG3A090L-TFE	575	3	15.7	84	1.835	0					071-0429-11

\* See Section F Introduction for more information.

FD13

### Electrical Data - Copelametic Small Refrigerant-Cooled Compressors

Model	Volts	PH	Max RLA	LRA	Resistance		Start Cap P/N	Run Cap P/N	Relay P/N	Part Type*	Protector P/N
					Start or Line to Line	Run or Line to WYE					
3DG3F40K0-TFC	208/230	3	35.7	215	0.295	0					071-0429-00
3DG3F40K0-TFD	460	3	15.6	106	1.178	0					071-0429-09
3DG3F40K0-TFE	575	3	15.7	84	1.835	0					071-0429-11
3DG3F40KE-TFC	208/230	3	35.7	215	0.295	0					071-0429-00
3DG3F40KE-TFD	460	3	15.6	106	1.178	0					071-0429-09
3DG3F40KE-TFE	575	3	15.7	84	1.835	0					071-0429-11
3DG3F40KL-TFC	208/230	3	35.7	215	0.295	0					071-0429-00
3DG3F40KL-TFD	460	3	15.6	106	1.178	0					071-0429-09
3DG3F40KL-TFE	575	3	15.7	84	1.835	0					071-0429-11
3DGHA090E-TFC	208/230	3	37	215	0.295	0					071-0429-00
3DGHA090E-TFD	460	3	16.7	106	1.178	0					071-0429-09
3DGHA090E-TFE	575	3	15.7	84	1.835	0					071-0429-11
3DGHA090L-TFC	208/230	3	37	215	0.295	0					071-0429-00
3DGHA090L-TFD	460	3	16.7	106	1.178	0					071-0429-09
3DGHA090L-TFE	575	3	15.7	84	1.835	0					071-0429-11
3DGHF40KE-TFC	208/230	3	37	215	0.295	0					071-0429-00
3DGHF40KE-TFD	460	3	16.7	106	1.178	0					071-0429-09
3DGHF40KE-TFE	575	3	15.7	84	1.835	0					071-0429-11
3DGHF40KL-TFC	208/230	3	37	215	0.295	0					071-0429-00
3DGHF40KL-TFD	460	3	16.7	106	1.178	0					071-0429-09
3DGHF40KL-TFE	575	3	15.7	84	1.835	0					071-0429-11
3DH3A0600-TFC	208/230	3	30.3	150	0.419	0					071-0429-08
3DH3A0600-TFD	460	3	13.7	77	1.676	0					071-0429-05

FD14 \* See Section F Introduction for more information.

### Electrical Data - Copelametic Small Refrigerant-Cooled Compressors

Model	Volts	PH	Max RLA	LRA	Resistance		Start Cap P/N	Run Cap P/N	Relay P/N	Part Type*	Protector P/N
					Start or Line to Line	Run or Line to WYE					
3DH3A0600-TFE	575	3	10.5	62	2.6	0					071-0429-03
3DH3A060E-TFC	208/230	3	30.3	150	0.419	0					071-0429-08
3DH3A060E-TFD	460	3	13.7	77	1.676	0					071-0429-05
3DH3A060E-TFE	575	3	10.5	62	2.6	0					071-0429-03
3DH3A060L-TFC	208/230	3	30.3	150	0.419	0					071-0429-08
3DH3A060L-TFD	460	3	13.7	77	1.676	0					071-0429-05
3DH3A060L-TFE	575	3	10.5	62	2.6	0					071-0429-03
3DH3F28K0-TFC	208/230	3	30.3	150	0.419	0					071-0429-08
3DH3F28K0-TFD	460	3	13.7	77	1.676	0					071-0429-05
3DH3F28K0-TFE	575	3	10.5	62	2.6	0					071-0429-03
3DH3F28KE-TFC	208/230	3	30.3	150	0.419	0					071-0429-08
3DH3F28KE-TFD	460	3	13.7	77	1.676	0					071-0429-05
3DH3F28KE-TFE	575	3	10.5	62	2.6	0					071-0429-03
3DH3F28KL-TFC	208/230	3	30.3	150	0.419	0					071-0429-08
3DH3F28KL-TFD	460	3	13.7	77	1.676	0					071-0429-05
3DH3F28KL-TFE	575	3	10.5	62	2.6	0					071-0429-03
3DHHA060E-TFC	208/230	3	26.8	150	0.419	0					071-0429-08
3DHHA060E-TFD	460	3	12	77	1.676	0					071-0429-05
3DHHA060E-TFE	575	3	10.5	62	2.6	0					071-0429-03
3DHHA060L-TFC	208/230	3	26.8	150	0.419	0					071-0429-08
3DHHA060L-TFD	460	3	12	77	1.676	0					071-0429-05
3DHHA060L-TFE	575	3	10.5	62	2.6	0					071-0429-03
3DHHF28KE-TFC	208/230	3	26.8	150	0.419	0					071-0429-08

\* See Section F Introduction for more information.

FD15

### Electrical Data - Copelametic Small Refrigerant-Cooled Compressors

Model	Volts	PH	Max RLA	LRA	Resistance		Start Cap P/N	Run Cap P/N	Relay P/N	Part Type*	Protector P/N
					Start or Line to Line	Run or Line to WYE					
3DHHF28KE-TFD	460	3	12	77	1.676	0					071-0429-05
3DHHF28KE-TFE	575	3	10.5	62	2.6	0					071-0429-03
3DHHF28KL-TFC	208/230	3	26.8	150	0.419	0					071-0429-08
3DHHF28KL-TFD	460	3	12	77	1.676	0					071-0429-05
3DHHF28KL-TFE	575	3	10.5	62	2.6	0					071-0429-03
3DJ3A0750-TFC	208/230	3	30.7	161	0.385	0					071-0429-04
3DJ3A0750-TFD	460	3	14.3	83	1.54	0					071-0429-09
3DJ3A0750-TFE	575	3	11	67	2.508	0					071-0429-03
3DJ3A075E-TFC	208/230	3	30.7	161	0.385	0					071-0429-04
3DJ3A075E-TFD	460	3	14.3	83	1.54	0					071-0429-09
3DJ3A075E-TFE	575	3	11	67	2.508	0					071-0429-03
3DJ3A075L-TFC	208/230	3	30.7	161	0.385	0					071-0429-04
3DJ3A075L-TFD	460	3	14.3	83	1.54	0					071-0429-09
3DJ3A075L-TFE	575	3	11	67	2.508	0					071-0429-03
3DJ3A0900-TFU	200	3	34.6	196	0.294	0					071-0429-20
3DJ3F33K0-TFC	208/230	3	30.7	161	0.385	0					071-0429-04
3DJ3F33K0-TFD	460	3	14.3	83	1.54	0					071-0429-09
3DJ3F33K0-TFE	575	3	11	67	2.508	0					071-0429-03
3DJ3F33KE-TFC	208/230	3	30.7	161	0.385	0					071-0429-04
3DJ3F33KE-TFD	460	3	14.3	83	1.54	0					071-0429-09
3DJ3F33KE-TFE	575	3	11	67	2.508	0					071-0429-03
3DJ3F33KL-TFC	208/230	3	30.7	161	0.385	0					071-0429-04
3DJ3F33KL-TFD	460	3	14.3	83	1.54	0					071-0429-09

FD16 \* See Section F Introduction for more information.

### Electrical Data - Copelametic Small Refrigerant-Cooled Compressors

Model	Volts	PH	Max RLA	LRA	Resistance		Start Cap P/N	Run Cap P/N	Relay P/N	Part Type*	Protector P/N
					Start or Line to Line	Run or Line to WYE					
3DJ3F33KL-TFE	575	3	11	67	2.508	0					071-0429-03
3DJHA075E-TFC	208/230	3	30.7	161	0.385	0					071-0429-04
3DJHA075E-TFD	460	3	15.7	83	1.54	0					071-0429-09
3DJHA075E-TFE	575	3	11	67	2.508	0					071-0429-03
3DJHA075L-TFC	208/230	3	30.7	161	0.385	0					071-0429-04
3DJHA075L-TFD	460	3	15.7	83	1.54	0					071-0429-09
3DJHA075L-TFE	575	3	11	67	2.508	0					071-0429-03
3DJHF33KE-TFC	208/230	3	30.7	161	0.385	0					071-0429-04
3DJHF33KE-TFD	460	3	15.7	83	1.54	0					071-0429-09
3DJHF33KE-TFE	575	3	11	67	2.508	0					071-0429-03
3DJHF33KL-TFC	208/230	3	30.7	161	0.385	0					071-0429-04
3DJHF33KL-TFD	460	3	15.7	83	1.54	0					071-0429-09
3DJHF33KL-TFE	575	3	11	67	2.508	0					071-0429-03
3DK3A0750-TFC	208/230	3	30.7	161	0.385	0					071-0429-04
3DK3A0750-TFD	460	3	15	83	1.54	0					071-0429-09
3DK3A0900-TFC	208/230	3	39	215	0.295	0					071-0429-00
3DK3A0900-TFD	460	3	16.9	106	1.178	0					071-0429-09
3DK3A0900-TFE	575	3	16.4	84	1.835	0					071-0429-11
3DK3A1200-TFC	208/230	3	48.1	275	0.229	0					071-0504-05
3DK3A1200-TFD	460	3	23.6	138	0.908	0					071-0504-02
3DK3A120E-TFC	208/230	3	48.1	275	0.229	0					071-0504-05
3DK3A120E-TFD	460	3	23.6	138	0.908	0					071-0504-02
3DK3A120L-TFC	208/230	3	48.1	275	0.229	0					071-0504-05

\* See Section F Introduction for more information.

FD17

### Electrical Data - Copelametic Small Refrigerant-Cooled Compressors

Model	Volts	PH	Max RLA	LRA	Resistance		Start Cap P/N	Run Cap P/N	Relay P/N	Part Type*	Protector P/N
					Start or Line to Line	Run or Line to WYE					
3DK3A120L-TFD	460	3	23.6	138	0.908	0					071-0504-02
3DK3R15M0-TFC	208/230	3	48.1	275	0.229	0					071-0504-05
3DK3R15M0-TFD	460	3	23.6	138	0.908	0					071-0504-02
3DK3R15ME-TFC	208/230	3	48.1	275	0.229	0					071-0504-05
3DK3R15ME-TFD	460	3	23.6	138	0.908	0					071-0504-02
3DK3R15ML-TFC	208/230	3	48.1	275	0.229	0					071-0504-05
3DK3R15ML-TFD	460	3	23.6	138	0.908	0					071-0504-02
3DK4A1200-TFD	460	3	23.6	138	0.908	0					071-0504-02
3DK4A120L-TFC	208/230	3	48.1	275	0.229	0					071-0504-05
3DK4A120L-TFD	460	3	23.6	138	0.908	0					071-0504-02
3DK4S11M0-TFC	208/230	3	38.6	240	0.255	0					071-0429-35
3DK4S11M0-TFD	460	3	18.6	115	1.02	0					071-0429-33
3DK4S11ML-TFC	208/230	3	38.6	240	0.255	0					071-0429-35
3DK4S11ML-TFD	460	3	18.6	115	1.02	0					071-0429-33
3DK8A0750-TFC	208/230	3	30.7	161	0.385	0					071-0429-04
3DK8A0750-TFD	460	3	15	83	1.54	0					071-0429-09
3DK8A075E-TFD	460	3	15	83	1.54	0					071-0429-09
3DKAA120L-TFC	208/230	3	48.1	275	0.229	0					071-0504-05
3DKAA120L-TFD	460	3	23.6	138	0.908	0					071-0504-02
3DKHA120E-TFC	208/230	3	48.1	275	0.229	0					071-0504-05
3DKHA120E-TFD	460	3	23.6	138	0.908	0					071-0504-02
3DKHA120L-TFC	208/230	3	48.1	275	0.229	0					071-0504-05
3DKHA120L-TFD	460	3	23.6	138	0.908	0					071-0504-02

FD18 \* See Section F Introduction for more information.



### Electrical Data - Copelametic Small Refrigerant-Cooled Compressors

Model	Volts	PH	Max RLA	LRA	Resistance		Start Cap P/N	Run Cap P/N	Relay P/N	Part Type*	Protector P/N
					Start or Line to Line	Run or Line to WYE					
3DKHR15ME-TFC	208/230	3	48.1	275	0.229	0					071-0504-05
3DKHR15ME-TFD	460	3	23.6	138	0.908	0					071-0504-02
3DKHR15ML-TFC	208/230	3	48.1	275	0.229	0					071-0504-05
3DKHR15ML-TFD	460	3	23.6	138	0.908	0					071-0504-02
3DKHS11ME-TFC	208/230	3	42.6	240	0.255	0					071-0429-35
3DKHS11ME-TFD	460	3	20.4	115	1.02	0					071-0429-33
3DKHS11ML-TFC	208/230	3	42.6	240	0.255	0					071-0429-35
3DKHS11ML-TFD	460	3	20.4	115	1.02	0					071-0429-33
3DP3A0500-TFC	208/230	3	18	115	0.603	0					071-0429-02
3DP3A0500-TFD	460	3	10.1	58	2.412	0					071-0429-03
3DP3A0500-TFE	575	3	7.5	43	3.794	0					071-0429-19
3DP3A0750-TFC	208/230	3	31.4	161	0.385	0					071-0429-04
3DP3A0750-TFD	460	3	16.1	83	1.54	0					071-0429-09
3DP3A0750-TFE	575	3	11	67	2.508	0					071-0429-03
3DP3A075E-TFD	460	3	16.1	83	1.54	0					071-0429-09
3DP3A0900-TFU	200	3	36.8	196	0.294	0					071-0429-20
3DP3A1000-TFC	208/230	3	43.6	215	0.295	0					071-0429-06
3DP3A1000-TFD	460	3	20	106	1.178	0					071-0429-17
3DP3A1000-TFE	575	3	16.5	84	1.835	0					071-0429-11
3DP3A100E-TFC	208/230	3	43.6	215	0.295	0					071-0429-06
3DP3A100E-TFD	460	3	20	106	1.178	0					071-0429-17
3DP3A100E-TFE	575	3	16.5	84	1.835	0					071-0429-11
3DP3A100L-TFC	208/230	3	43.6	215	0.295	0					071-0429-06

\* See Section F Introduction for more information.

FD19

### Electrical Data - Copelametic Small Refrigerant-Cooled Compressors

Model	Volts	PH	Max RLA	LRA	Resistance		Start Cap P/N	Run Cap P/N	Relay P/N	Part Type*	Protector P/N
					Start or Line to Line	Run or Line to WYE					
3DP3A100L-TFD	460	3	20	106	1.178	0					071-0429-17
3DP3A100L-TFE	575	3	16.5	84	1.835	0					071-0429-11
3DP3R12M0-TFC	208/230	3	43.6	215	0.295	0					071-0429-06
3DP3R12M0-TFD	460	3	20	106	1.178	0					071-0429-17
3DP3R12M0-TFE	575	3	16.5	84	1.835	0					071-0429-11
3DP3R12ME-TFC	208/230	3	43.6	215	0.295	0					071-0429-06
3DP3R12ME-TFD	460	3	20	106	1.178	0					071-0429-17
3DP3R12ME-TFE	575	3	16.5	84	1.835	0					071-0429-11
3DP3R12ML-TFC	208/230	3	43.6	215	0.295	0					071-0429-06
3DP3R12ML-TFD	460	3	20	106	1.178	0					071-0429-17
3DP3R12ML-TFE	575	3	16.5	84	1.835	0					071-0429-11
3DPHA100E-TFC	208/230	3	43.6	215	0.295	0					071-0429-06
3DPHA100E-TFD	460	3	20	106	1.178	0					071-0429-17
3DPHA100E-TFE	575	3	16.5	84	1.835	0					071-0429-11
3DPHA100L-TFC	208/230	3	43.6	215	0.295	0					071-0429-06
3DPHA100L-TFD	460	3	20	106	1.178	0					071-0429-17
3DPHA100L-TFE	575	3	16.5	84	1.835	0					071-0429-11
3DPHR12ME-TFC	208/230	3	43.6	215	0.295	0					071-0429-06
3DPHR12ME-TFD	460	3	20	106	1.178	0					071-0429-17
3DPHR12ME-TFE	575	3	16.5	84	1.835	0					071-0429-11
3DPHR12ML-TFC	208/230	3	43.6	215	0.295	0					071-0429-06
3DPHR12ML-TFD	460	3	20	106	1.178	0					071-0429-17
3DPHR12ML-TFE	575	3	16.5	84	1.835	0					071-0429-11

FD20 \* See Section F Introduction for more information.

### Electrical Data - Copelametic Small Refrigerant-Cooled Compressors

Model	Volts	PH	Max RLA	LRA	Resistance		Start Cap P/N	Run Cap P/N	Relay P/N	Part Type*	Protector P/N
					Start or Line to Line	Run or Line to WYE					
3DR3A1000-TFC	208/230	3	41.4	215	0.295	0					071-0429-00
3DR3A1000-TFD	460	3	18.6	106	1.178	0					071-0429-09
3DR3A1000-TFE	575	3	15.4	84	1.835	0					071-0429-11
3DR3A100E-TFC	208/230	3	41.4	215	0.295	0					071-0429-00
3DR3A100E-TFD	460	3	18.6	106	1.178	0					071-0429-09
3DR3A100E-TFE	575	3	15.4	84	1.835	0					071-0429-11
3DR3A100L-TFC	208/230	3	41.4	215	0.295	0					071-0429-00
3DR3A100L-TFD	460	3	18.6	106	1.178	0					071-0429-09
3DR3A100L-TFE	575	3	15.4	84	1.835	0					071-0429-11
3DR3F46K0-TFC	208/230	3	41.4	215	0.295	0					071-0429-00
3DR3F46K0-TFD	460	3	18.6	106	1.178	0					071-0429-09
3DR3F46K0-TFE	575	3	15.4	84	1.835	0					071-0429-11
3DR3F46KE-TFC	208/230	3	41.4	215	0.295	0					071-0429-00
3DR3F46KE-TFD	460	3	18.6	106	1.178	0					071-0429-09
3DR3F46KL-TFC	208/230	3	41.4	215	0.295	0					071-0429-00
3DR3F46KL-TFD	460	3	18.6	106	1.178	0					071-0429-09
3DR3F46KL-TFE	575	3	15.4	84	1.835	0					071-0429-11
3DRHA100E-TFC	208/230	3	41.4	215	0.295	0					071-0429-00
3DRHA100E-TFD	460	3	18.6	106	1.178	0					071-0429-09
3DRHA100E-TFE	575	3	16.2	84	1.835	0					071-0429-11
3DRHA100L-TFC	208/230	3	41.4	215	0.295	0					071-0429-00
3DRHA100L-TFD	460	3	18.6	106	1.178	0					071-0429-09
3DRHA100L-TFE	575	3	16.2	84	1.835	0					071-0429-11

\* See Section F Introduction for more information.

FD21

### Electrical Data - Copelametic Small Refrigerant-Cooled Compressors

Model	Volts	PH	Max RLA	LRA	Resistance		Start Cap P/N	Run Cap P/N	Relay P/N	Part Type*	Protector P/N
					Start or Line to Line	Run or Line to WYE					
3DRHF46KE-TFC	208/230	3	41.4	215	0.295	0					071-0429-00
3DRHF46KE-TFD	460	3	18.6	106	1.178	0					071-0429-09
3DRHF46KE-TFE	575	3	16.2	84	1.835	0					071-0429-11
3DRHF46KL-TFC	208/230	3	41.4	215	0.295	0					071-0429-00
3DRHF46KL-TFD	460	3	18.6	106	1.178	0					071-0429-09
3DRHF46KL-TFE	575	3	16.2	84	1.835	0					071-0429-11
3DS3A0750-TFC	208/230	3	32	161	0.385	0					071-0429-04
3DS3A0750-TFD	460	3	16.4	83	1.54	0					071-0429-09
3DS3A0750-TFE	575	3	11.5	67	2.508	0					071-0429-03
3DS3A1000-TFC	208/230	3	42	215	0.295	0					071-0429-00
3DS3A1000-TFD	460	3	18.6	106	1.178	0					071-0429-09
3DS3A1000-TFE	575	3	16.8	84	1.835	0					071-0429-11
3DS3A100E-TFC	208/230	3	42	215	0.295	0					071-0429-00
3DS3A100E-TFD	460	3	18.6	106	1.178	0					071-0429-09
3DS3A100E-TFE	575	3	16.8	84	1.835	0					071-0429-11
3DS3A100L-TFC	208/230	3	42	215	0.295	0					071-0429-00
3DS3A100L-TFD	460	3	18.6	106	1.178	0					071-0429-09
3DS3A100L-TFE	575	3	16.8	84	1.835	0					071-0429-11
3DS3A1500-TFC	208/230	3	59.6	275	0.229	0					071-0504-04
3DS3A1500-TFD	460	3	29	138	0.908	0					071-0504-00
3DS3A1500-TFE	575	3	23.6	110	1.433	0					071-0504-01
3DS3A150E-TFC	208/230	3	59.6	275	0.229	0					071-0504-04
3DS3A150E-TFD	460	3	29	138	0.908	0					071-0504-00

FD22 \* See Section F Introduction for more information.

### Electrical Data - Copelametic Small Refrigerant-Cooled Compressors

Model	Volts	PH	Max RLA	LRA	Resistance		Start Cap P/N	Run Cap P/N	Relay P/N	Part Type*	Protector P/N
					Start or Line to Line	Run or Line to WYE					
3DS3A150E-TFE	575	3	23.6	110	1.433	0					071-0504-01
3DS3A150L-TFC	208/230	3	59.6	275	0.229	0					071-0504-04
3DS3A150L-TFD	460	3	29	138	0.908	0					071-0504-00
3DS3A150L-TFE	575	3	23.6	110	1.433	0					071-0504-01
3DS3F30K0-TFC	208/230	3	32	161	0.385	0					071-0429-04
3DS3F30K0-TFD	460	3	16.4	83	1.54	0					071-0429-09
3DS3F46K0-TFC	208/230	3	42	215	0.295	0					071-0429-00
3DS3F46K0-TFD	460	3	18.6	106	1.178	0					071-0429-09
3DS3F46K0-TFE	575	3	16.8	84	1.835	0					071-0429-11
3DS3F46KE-TFC	208/230	3	42	215	0.295	0					071-0429-00
3DS3F46KE-TFD	460	3	18.6	106	1.178	0					071-0429-09
3DS3F46KE-TFE	575	3	16.8	84	1.835	0					071-0429-11
3DS3F46KL-TFC	208/230	3	42	215	0.295	0					071-0429-00
3DS3F46KL-TFD	460	3	18.6	106	1.178	0					071-0429-09
3DS3F46KL-TFE	575	3	16.8	84	1.835	0					071-0429-11
3DS3R17M0-TFC	208/230	3	59.6	275	0.229	0					071-0504-04
3DS3R17M0-TFD	460	3	29	138	0.908	0					071-0504-00
3DS3R17M0-TFE	575	3	23.6	110	1.433	0					071-0504-01
3DS3R17ME-TFC	208/230	3	59.6	275	0.229	0					071-0504-04
3DS3R17ME-TFD	460	3	29	138	0.908	0					071-0504-00
3DS3R17ME-TFE	575	3	23.6	110	1.433	0					071-0504-01
3DS3R17ML-TFC	208/230	3	59.6	275	0.229	0					071-0504-04
3DS3R17ML-TFD	460	3	29	138	0.908	0					071-0504-00

\* See Section F Introduction for more information.

FD23

### Electrical Data - Copelametic Small Refrigerant-Cooled Compressors

Model	Volts	PH	Max RLA	LRA	Resistance		Start Cap P/N	Run Cap P/N	Relay P/N	Part Type*	Protector P/N
					Start or Line to Line	Run or Line to WYE					
3DS3R17ML-TFE	575	3	23.6	110	1.433	0					071-0504-01
3DS4A0750-TFC	208/230	3	32	161	0.385	0					071-0429-04
3DS4A0750-TFD	460	3	16.4	83	1.54	0					071-0429-09
3DS4A1000-TFC	208/230	3	42	215	0.295	0					071-0429-00
3DS4A1000-TFD	460	3	18.6	106	1.178	0					071-0429-09
3DS4A1500-TFC	208/230	3	59.6	275	0.229	0					071-0504-04
3DS4A1500-TFD	460	3	29	138	0.908	0					071-0504-00
3DS4A1500-TFE	575	3	23.6	110	1.433	0					071-0504-01
3DS4S12M0-TFC	208/230	3	41.9	280	0.22	0					071-0504-08
3DS4S12M0-TFD	460	3	21.3	136	0.823	0					071-0429-34
3DS4S12ME-TFC	208/230	3	47.1	280	0.22	0					071-0504-08
3DS4S12ME-TFD	460	3	22.8	136	0.823	0					071-0429-34
3DS4S12ML-TFC	208/230	3	47.1	280	0.22	0					071-0504-08
3DS4S12ML-TFD	460	3	22.8	136	0.823	0					071-0429-34
3DS8A0750-TFD	460	3	16.4	83	1.54	0					071-0429-09
3DS8A0751-TFD	460	3	16.4	83	1.54	0					071-0429-09
3DS8A076E-TFD	460	3	16.4	83	1.54	0					071-0429-09
3DS8A1000-TFC	208/230	3	42	215	0.295	0					071-0429-00
3DS8A100E-TFC	208/230	3	42	215	0.295	0					071-0429-00
3DS8F30K1-TFD	460	3	16.4	83	1.54	0					071-0429-09
3DS8R11ME-TFD	460	3	16.4	83	1.54	0					071-0429-09
3DSTA075E-TFC	208/230	3	32	161	0.385	0					071-0429-04
3DSTA075E-TFD	460	3	16.4	83	1.54	0					071-0429-09

FD24 \* See Section F Introduction for more information.

### Electrical Data - Copelametic Small Refrigerant-Cooled Compressors

Model	Volts	PH	Max RLA	LRA	Resistance		Start Cap P/N	Run Cap P/N	Relay P/N	Part Type*	Protector P/N
					Start or Line to Line	Run or Line to WYE					
3DSTR11ME-TFD	460	3	16.4	83	1.54	0					071-0429-09
3DT3A0750-TFC	208/230	3	32	161	0.385	0					071-0429-04
3DT3A0750-TFD	460	3	16.4	83	1.54	0					071-0429-09
3DT3A0750-TFE	575	3	11.5	67	2.508	0					071-0429-03
3DT3A1000-TFC	208/230	3	42	215	0.295	0					071-0429-00
3DT3A1000-TFD	460	3	18.6	106	1.178	0					071-0429-09
3DT3A1000-TFE	575	3	16.8	84	1.835	0					071-0429-11
3DT3A1500-TFC	208/230	3	59.6	275	0.229	0					071-0504-04
3DT3A1500-TFD	460	3	29	138	0.908	0					071-0504-00
3DT3A1500-TFE	575	3	23.6	110	1.433	0					071-0504-01
3DT3A150E-TFC	208/230	3	59.6	275	0.229	0					071-0504-04
3DT3A150E-TFD	460	3	29	138	0.908	0					071-0504-00
3DT3A150E-TFE	575	3	23.6	110	1.433	0					071-0504-01
3DT3A150L-TFC	208/230	3	59.6	275	0.229	0					071-0504-04
3DT3A150L-TFD	460	3	29	138	0.908	0					071-0504-00
3DT3A150L-TFE	575	3	23.6	110	1.433	0					071-0504-01
3DT3R11M0-TFC	208/230	3	42	215	0.295	0					071-0429-00
3DT3R11M0-TFD	460	3	18.6	106	1.178	0					071-0429-09
3DT3R11M0-TFE	575	3	16.8	84	1.835	0					071-0429-11
3DT3R17M0-TFC	208/230	3	59.6	275	0.229	0					071-0504-04
3DT3R17M0-TFD	460	3	29	138	0.908	0					071-0504-00
3DT3R17M0-TFE	575	3	23.6	110	1.433	0					071-0504-01
3DT3R17ME-TFC	208/230	3	59.6	275	0.229	0					071-0504-04

\* See Section F Introduction for more information.

FD25

### Electrical Data - Copelametic Small Refrigerant-Cooled Compressors

Model	Volts	PH	Max RLA	LRA	Resistance		Start Cap P/N	Run Cap P/N	Relay P/N	Part Type*	Protector P/N
					Start or Line to Line	Run or Line to WYE					
3DT3R17ME-TFD	460	3	29	138	0.908	0					071-0504-00
3DT3R17ME-TFE	575	3	23.6	110	1.433	0					071-0504-01
3DT3R17ML-TFC	208/230	3	59.6	275	0.229	0					071-0504-04
3DT3R17ML-TFD	460	3	29	138	0.908	0					071-0504-00
3DT3R17ML-TFE	575	3	23.6	110	1.433	0					071-0504-01
3DT4S12M0-TFC	208/230	3	41.9	280	0.22	0					071-0504-08
3DT4S12M0-TFD	460	3	21.3	136	0.823	0					071-0429-34
3DT4S12ML-TFC	208/230	3	41.9	280	0.22	0					071-0504-08
3DT4S12ML-TFD	460	3	21.3	136	0.823	0					071-0429-34
3DT8A0750-TFD	460	3	16.4	83	1.54	0					071-0429-09
3DT8A075E-TFD	460	3	16.4	83	1.54	0					071-0429-09
3DT8R11ME-TFD	460	3	16.4	83	1.54	0					071-0429-09
3DTHA100E-TFD	460	3	18.6	106	1.178	0					071-0429-09
3DTHA150E-TFC	208/230	3	59.6	275	0.229	0					071-0504-04
3DTHA150E-TFD	460	3	29	138	0.908	0					071-0504-00
3DTHA150E-TFE	575	3	23.6	110	1.433	0					071-0504-01
3DTHA150L-TFC	208/230	3	59.6	275	0.229	0					071-0504-04
3DTHA150L-TFD	460	3	29	138	0.908	0					071-0504-00
3DTHA150L-TFE	575	3	23.6	110	1.433	0					071-0504-01
3DTHR11ME-TFD	460	3	18.6	106	1.178	0					071-0429-09
3DTHR17ME-TFC	208/230	3	59.6	275	0.229	0					071-0504-04
3DTHR17ME-TFD	460	3	29	138	0.908	0					071-0504-00
3DTHR17ME-TFE	575	3	23.6	110	1.433	0					071-0504-01

FD26 \* See Section F Introduction for more information.



### Electrical Data - Copelametic Small Refrigerant-Cooled Compressors

Model	Volts	PH	Max RLA	LRA	Resistance		Start Cap P/N	Run Cap P/N	Relay P/N	Part Type*	Protector P/N
					Start or Line to Line	Run or Line to WYE					
3DTHR17ML-TFC	208/230	3	59.6	275	0.229	0					071-0504-04
3DTHR17ML-TFD	460	3	29	138	0.908	0					071-0504-00
3DTHR17ML-TFE	575	3	23.6	110	1.433	0					071-0504-01
3DTHS12ME-TFC	208/230	3	47.1	280	0.22	0					071-0504-08
3DTHS12ME-TFD	460	3	22.8	136	0.823	0					071-0429-34
3DTHS12ML-TFC	208/230	3	47.1	280	0.22	0					071-0504-08
3DTHS12ML-TFD	460	3	22.8	136	0.823	0					071-0429-34
3RA1-0310-TAC	208/230	3	NA	82	0.9	0.47					071-0090-17
3RA1-0310-TAD	460	3	NA	41	3.6	1.9					071-0090-22
3RA1-0310-TAU	200	3	11.4	82	0.944	0.444					071-0090-32
3RA1-0311-TAC	208/230	3	14.1	82	0.837	0.42					071-0090-32
3RA1-0311-TAD	460	3	6.3	41	3.309	1.653					071-0090-22
3RA1-031A-TAC	208/230	3	14.1	82	0.837	0.42					071-0090-32
3RA1-031A-TAD	460	3	6.3	41	3.309	1.653					071-0090-22
3RA1-031L-TAC	208/230	3	13.1	82	0.9	0.47					071-0090-17
3RA1-031L-TAD	460	3	6.6	41	3.6	1.9					071-0090-22
3RA2-0310-CAB	230	1	NA	86	2.54	0.61	014-0036-22	014-0064-14	040-0166-28	RP	071-0119-02
3RA2-031A-CAB	230	1	NA	86	2.54	0.61	014-0036-22	014-0064-14	040-0166-28	RP	071-0119-02
3RA2-031L-CAB	230	1	17.8	86	2.54	0.61	014-0036-22	014-0064-14	040-0166-28	RP	071-0119-02
3RAA-0310-TAU	200	3	13.1	82	0.9	0.47					071-0090-17
3RAA-031E-TAC	208/230	3	14.1	82	0.837	0.42					071-0090-32
3RAA-031E-TAD	460	3	6.3	41	3.309	1.653					071-0090-22
3RAA-031L-TAC	208/230	3	14.1	82	0.837	0.42					071-0090-32

\* See Section F Introduction for more information.

FD27

### Electrical Data - Copelametic Small Refrigerant-Cooled Compressors

Model	Volts	PH	Max RLA	LRA	Resistance		Start Cap P/N	Run Cap P/N	Relay P/N	Part Type*	Protector P/N
					Start or Line to Line	Run or Line to WYE					
3RAA-031L-TAD	460	3	6.3	41	3.309	1.653					071-0090-22
3RK1-0300-TAE	575	3	5.1	30	5.4	2.7					071-0090-16
3RK1-0310-TAC	208/230	3	11.8	82	0.9	0.47					071-0090-02
3RK1-0310-TAD	460	3	5.2	41	3.6	1.9					071-0090-03
3RK1-031A-TAC	208/230	3	11.8	82	0.9	0.47					071-0090-02
3RK1-031A-TAD	460	3	5.2	41	3.6	1.9					071-0090-03
3RK2-0310-CAB	230	1	19.6	86	2.54	0.61	014-0036-22	014-0064-14	040-0166-28	RP	071-0119-00
3RK2-031A-CAB	230	1	19.6	86	2.54	0.61	014-0036-22	014-0064-14	040-0166-28	RP	071-0119-00
3RKA-031E-FXX	55	3	NA	320	0.17	0					
9RA1-0505-TFC	208/230	3	16.7	115	0.519	0.26					071-0086-09
9RA1-0505-TFD	460	3	8.6	53	2.08	1.015					071-0086-17
9RA1-0505-TFE	575	3	7.8	42	3.17	1.585					071-0086-29
9RA1-0506-CFB	230	1	26.9	125	1.4	0.37	014-0006-14	014-0064-18	040-0166-23	RP	071-0476-01
9RA1-050A-CFB	230	1	26.9	125	1.4	0.37	014-0006-14	014-0064-18	040-0166-23	RP	071-0476-01
9RA1-050A-TFC	208/230	3	16.7	115	0.519	0.26					071-0086-09
9RA1-050A-TFD	460	3	8.6	53	2.08	1.015					071-0086-17
9RB1-0505-TFC	208/230	3	15.9	115	0.519	0.26					071-0086-09
9RB1-0505-TFD	460	3	7.9	53	2.08	1.015					071-0086-17
9RB1-0505-TFE	575	3	7.8	42	3.17	1.585					071-0086-29
9RB1-050A-TFC	208/230	3	15.9	115	0.519	0.26					071-0086-09
9RB1-050A-TFD	460	3	7.9	53	2.08	1.015					071-0086-17
9RB1-0765-TFC	208/230	3	32.1	164	0.338	0.169					071-0086-22
9RB1-0765-TFD	460	3	15.4	82	1.351	0.675					071-0086-20

FD28 \* See Section F Introduction for more information.

### Electrical Data - Copelametic Small Refrigerant-Cooled Compressors

Model	Volts	PH	Max RLA	LRA	Resistance		Start Cap P/N	Run Cap P/N	Relay P/N	Part Type*	Protector P/N
					Start or Line to Line	Run or Line to WYE					
9RB1-0765-TFE	575	3	14	63.8	2.16	1.08					071-0086-40
9RB1-0765-TFU	200	3	NA	141	0.3	0.151					071-0086-43
9RB1-076A-TFC	208/230	3	32.1	164	0.338	0.169					071-0086-22
9RB1-076A-TFD	460	3	15.4	82	1.351	0.675					071-0086-20
9RB1-076L-TFC	208/230	3	32.1	164	0.338	0.169					071-0086-22
9RB1-076L-TFD	460	3	15.4	82	1.351	0.675					071-0086-20
9RB2-0765-TFC	208/230	3	32.1	164	0.338	0.169					071-0086-22
9RB2-0765-TFD	460	3	15.4	82	1.351	0.675					071-0086-20
9RB2-0765-TFE	575	3	14	63.8	2.16	1.08					071-0086-40
9RB2-076A-TFC	208/230	3	32.1	164	0.338	0.169					071-0086-22
9RB4-0505-TFC	208/230	3	15.9	115	0.519	0.26					071-0086-09
9RB4-0505-TFD	460	3	7.9	53	2.08	1.015					071-0086-17
9RB6-0505-TFC	208/230	3	15.9	115	0.519	0.26					071-0086-09
9RC1-0765-TFC	208/230	3	32.9	164	0.338	0.169					071-0086-22
9RC1-0765-TFD	460	3	15.8	82	1.351	0.675					071-0086-20
9RC1-0765-TFE	575	3	14	63.8	2.16	1.08					071-0086-40
9RC1-0765-TFU	200	3	NA	141	0.3	0.151					071-0086-43
9RC1-076A-TFC	208/230	3	32.9	164	0.338	0.169					071-0086-22
9RC1-076A-TFD	460	3	15.8	82	1.351	0.675					071-0086-20
9RC1-1015-TF7	380	3	NA	110	0.878	0					071-0429-17
9RC1-1015-TFC	208/230	3	44	208	0.219	0					071-0504-06
9RC1-1015-TFD	460	3	20	110	0.878	0					071-0429-17
9RC1-1015-TFE	575	3	17.5	88.2	1.48	0					071-0429-11

\* See Section F Introduction for more information.

FD29

### Electrical Data - Copelametic Small Refrigerant-Cooled Compressors

Model	Volts	PH	Max RLA	LRA	Resistance		Start Cap P/N	Run Cap P/N	Relay P/N	Part Type*	Protector P/N
					Start or Line to Line	Run or Line to WYE					
9RC1-101A-TFC	208/230	3	44	208	0.219	0					071-0504-06
9RC1-101A-TFD	460	3	20	110	0.878	0					071-0429-17
9RC3-1015-TFD	460	3	20	110	0.878	0					071-0429-17
9RC3-1015-TFE	575	3	17.5	88.2	1.48	0					071-0429-11
9RC3-101L-TFD	460	3	20	110	0.878	0					071-0429-17
9RJ1-0505-TFC	208/230	3	15.9	115	0.519	0.26					071-0086-09
9RJ1-0505-TFD	460	3	7.9	53	2.08	1.015					071-0086-17
9RJ1-0505-TFE	575	3	7.8	42	3.17	1.585					071-0086-29
9RJ1-050A-TFC	208/230	3	15.9	115	0.519	0.26					071-0086-09
9RJ1-0765-TFC	208/230	3	31.7	164	0.338	0.169					071-0086-21
9RJ1-0765-TFD	460	3	14.7	82	1.351	0.675					071-0086-20
9RJ1-0765-TFE	575	3	10.7	63.8	2.16	1.08					071-0086-40
9RJ1-076A-TFC	208/230	3	31.7	164	0.338	0.169					071-0086-21
9RJ1-076A-TFD	460	3	14.7	82	1.351	0.675					071-0086-20
9RJ1-076L-TFC	208/230	3	31.7	164	0.338	0.169					071-0086-21
9RJ1-076L-TFD	460	3	14.7	82	1.351	0.675					071-0086-20
9RJ2-0765-TFC	208/230	3	31.7	164	0.338	0.169					071-0086-21
9RJ2-0765-TFE	575	3	10.7	63.8	2.16	1.08					071-0086-40
9RP2-0765-TFC	208/230	3	32.9	164	0.338	0.169					071-0086-22
9RP2-0765-TFD	460	3	14.1	82	1.351	0.675					071-0086-20
9RP2-0765-TFE	575	3	14	63.8	2.16	1.08					071-0086-40
9RP2-1015-TFC	208/230	3	44	208	0.219	0					071-0504-06
9RP2-1015-TFD	460	3	20	110	0.878	0					071-0429-17

FD30 \* See Section F Introduction for more information.

### Electrical Data - Copelametic Small Refrigerant-Cooled Compressors

Model	Volts	PH	Max RLA	LRA	Resistance		Start Cap P/N	Run Cap P/N	Relay P/N	Part Type*	Protector P/N
					Start or Line to Line	Run or Line to WYE					
9RP2-1015-TFE	575	3	17.5	88.2	1.48	0					071-0429-11
9RP2-101A-TFC	208/230	3	44	208	0.219	0					071-0504-06
9RP3-1015-TFD	460	3	20	110	0.878	0					071-0429-17
9RP3-1015-TFE	575	3	17.5	88.2	1.48	0					071-0429-11
9RS1-1015-TSU	200	3	NA	203	0.204	0					071-0581-02
9RS1-1505-TF7	380	3	NA	144	0.908	0					071-0504-00
9RS1-1505-TFD	460	3	28.5	144	0.908	0					071-0504-00
9RS1-1505-TFE	575	3	22.5	127	1.036	0					071-0504-01
9RS1-1505-TSC	208/230	3	56.4	284	0.229	0					071-0581-02
9RS1-150A-TFD	460	3	28.5	144	0.908	0					071-0504-00
9RS1-150A-TSC	208/230	3	56.4	284	0.229	0					071-0581-02
9RS2-0765-TFC	208/230	3	29.4	164	0.338	0.169					071-0086-23
9RS2-0765-TFD	460	3	16.5	82	1.351	0.675					071-0086-20
9RS2-0765-TFE	575	3	14	63.8	2.16	1.08					071-0086-26
9RS2-076A-TFC	208/230	3	29.4	164	0.338	0.169					071-0086-23
9RS2-076A-TFD	460	3	16.5	82	1.351	0.675					071-0086-20
9RS2-1015-TFD	460	3	19	110	0.878	0					071-0429-17
9RS3-0765-TFC	208/230	3	29.4	164	0.338	0.169					071-0086-23
9RS3-0765-TFD	460	3	16.5	82	1.351	0.675					071-0086-20
9RS3-0765-TFE	575	3	14	63.8	2.16	1.08					071-0086-26
9RS3-076A-TFC	208/230	3	29.4	164	0.338	0.169					071-0086-23
9RS3-076A-TFD	460	3	16.5	82	1.351	0.675					071-0086-20
9RS3-1015-TFC	208/230	3	41	208	0.219	0					071-0504-06

\* See Section F Introduction for more information.

FD31

### Electrical Data - Copelametic Small Refrigerant-Cooled Compressors

Model	Volts	PH	Max RLA	LRA	Resistance		Start Cap P/N	Run Cap P/N	Relay P/N	Part Type*	Protector P/N
					Start or Line to Line	Run or Line to WYE					
9RS3-1015-TFD	460	3	19	110	0.878	0					071-0429-17
9RS3-1015-TFE	575	3	15.5	88.2	1.48	0					071-0429-11
9RS3-1015-TSU	200	3	NA	203	0.204	0					071-0581-02
9RS5-0765-TFC	208/230	3	29.4	164	0.338	0.169					071-0086-23
9RS7-0765-TFC	208/230	3	29.4	164	0.338	0.169					071-0086-23
9RS7-0765-TFD	460	3	16.5	82	1.351	0.675					071-0086-20
9RSB-076A-TFC	208/230	3	29.4	164	0.338	0.169					071-0086-23
9RSC-0765-TFC	208/230	3	29.4	164	0.338	0.169					071-0086-23
9RSC-0765-TFD	460	3	16.5	82	1.351	0.675					071-0086-20
9RSD-0765-TFC	208/230	3	29.4	164	0.338	0.169					071-0086-23
9RSD-0765-TFD	460	3	16.5	82	1.351	0.675					071-0086-20
9RT1-1505-TFD	460	3	28.5	144	0.908	0					071-0504-00
9RT1-1505-TFE	575	3	22.5	127	1.036	0					071-0504-01
9RT1-1505-TSC	208/230	3	56.4	284	0.229	0					071-0581-02
9RT1-150A-TFD	460	3	28.5	144	0.908	0					071-0504-00
9RZ1-0765-TFU	200	3	NA	141	0.3	0.151					071-0086-43
9TH1-1015-TFC	208/230	3	37.4	208	0.219	0					071-0504-06
9TH1-1015-TFD	460	3	17.5	110	0.878	0					071-0429-17
9TH1-101A-TFC	208/230	3	37.4	208	0.219	0					071-0504-06
9TH1-101A-TFD	460	3	17.5	110	0.878	0					071-0429-17
9TH2-101E-TFC	208/230	3	40.7	220	0.219	0					071-0504-06
9TH2-101E-TFD	460	3	17.9	110	0.878	0					071-0429-17
9TK1-0505-TFC	208/230	3	19.6	115	0.519	0.26					071-0086-38

FD32 \* See Section F Introduction for more information.

### Electrical Data - Copelametic Small Refrigerant-Cooled Compressors

Model	Volts	PH	Max RLA	LRA	Resistance		Start Cap P/N	Run Cap P/N	Relay P/N	Part Type*	Protector P/N
					Start or Line to Line	Run or Line to WYE					
9TK1-0505-TFD	460	3	8.3	53	2.08	1.015					071-0086-17
9TK1-0505-TFE	575	3	7.8	42	3.17	1.585					071-0086-29
9TK1-050A-TFC	208/230	3	19.6	115	0.519	0.26					071-0086-38
9TK1-050A-TFD	460	3	8.3	53	2.08	1.015					071-0086-17
9TK2-050E-TFC	208/230	3	20.3	115	0.519	0.26					071-0086-38
9TK2-050E-TFD	460	3	8.3	53	2.08	1.015					071-0429-31
9TL1-0765-TFC	208/230	3	30	164	0.338	0.169					071-0086-22
9TL1-0765-TFE	575	3	9.7	63.8	2.16	1.08					071-0086-40
9TL1-076A-TFC	208/230	3	30	164	0.338	0.169					071-0086-22
9TL1-076A-TFD	460	3	14.5	82	1.351	0.675					071-0086-20
9TL2-076E-TFC	208/230	3	28.9	164	0.338	0.169					071-0086-22
9TL2-076E-TFD	460	3	13.1	82	1.351	0.675					071-0086-20
ERA1-0200-TAC	208/230	3	6.6	46	1.675	0.84					071-0090-00
ERA1-0200-TAD	460	3	3.5	23	6.692	3.346					071-0090-08
ERA1-0200-TAE	575	3	3.5	20	9.3	4.905					071-0090-15
ERA1-020A-TAD	460	3	3.5	23	6.692	3.346					071-0090-08
ERA2-0200-CAB	230	1	10.4	58	2.7	1.125	014-0036-22	014-0064-11	040-0166-20	RP	071-0103-02
ERA2-020A-CAB	230	1	10.4	58	2.7	1.125	014-0036-22	014-0064-11	040-0166-20	RP	071-0103-02
ERC1-0200-TAC	208/230	3	6.8	46	1.675	0.84					071-0090-00
ERC1-0200-TAD	460	3	3.6	23	6.692	3.346					071-0090-08
ERC1-0200-TAE	575	3	NA	20	9.3	4.905					071-0090-15
ERC1-020L-TAC	208/230	3	6.8	46	1.675	0.84					071-0090-00
ERC1-020L-TAD	460	3	3.6	23	6.692	3.346					071-0090-08

\* See Section F Introduction for more information.

FD33

### Electrical Data - Copelametic Small Refrigerant-Cooled Compressors

Model	Volts	PH	Max RLA	LRA	Resistance		Start Cap P/N	Run Cap P/N	Relay P/N	Part Type*	Protector P/N
					Start or Line to Line	Run or Line to WYE					
ERC2-0200-CAB	230	1	10.9	58	2.7	1.125	014-0036-22	014-0064-11	040-0166-20	RP	071-0099-01
ERC2-020A-CAB	230	1	10.9	58	2.7	1.125	014-0036-22	014-0064-11	040-0166-20	RP	071-0099-01
ERC2-020L-CAB	230	1	10.9	58	2.7	1.125	014-0036-22	014-0064-11	040-0166-20	RP	071-0099-01
ERCA-020A-TAC	208/230	3	6.8	46	1.675	0.84					071-0090-00
ERCA-020E-TAD	460	3	3.5	23	6.692	3.346					071-0090-08
ERCA-020E-TAE	575	3	3.1	20	9.3	4.905					071-0090-15
ERCA-020L-TAD	460	3	3.5	23	6.692	3.346					071-0090-08
ERCA-020L-TAE	575	3	3.1	20	9.3	4.905					071-0090-15
ERCA-021E-TAC	208/230	3	8.8	46	1.675	0.84					071-0090-49
ERCA-021L-TAC	208/230	3	8.8	46	1.675	0.84					071-0090-49
ERF1-0300-TAE	575	3	5.2	30	5.4	2.7					071-0090-16
ERF1-0310-FXX	55	3	NA	320	0.17	0					
ERF1-0310-TAC	208/230	3	11.7	82	0.9	0.47					071-0090-02
ERF1-0310-TAD	460	3	6.4	41	3.6	1.9					071-0090-10
ERF1-0311-TAC	208/230	3	12.4	82	0.837	0.42					071-0090-36
ERF1-0311-TAD	460	3	5.8	41	3.309	1.653					071-0090-10
ERF1-031L-TAC	208/230	3	11.7	82	0.9	0.47					071-0090-02
ERF1-031L-TAD	460	3	6.4	41	3.6	1.9					071-0090-10
ERF2-0310-CAB	230	1	18.3	86	2.54	0.61	014-0036-22	014-0064-14	040-0166-28	RP	071-0119-00
ERF2-031L-CAB	230	1	18.3	86	2.54	0.61	014-0036-22	014-0064-14	040-0166-28	RP	071-0119-00
ERFA-0311-TAD	460	3	5.8	41	3.309	1.653					071-0090-10
ERFA-031E-TAC	208/230	3	12.4	82	0.837	0.42					071-0090-36
ERFA-031E-TAD	460	3	5.8	41	3.309	1.653					071-0090-10

FD34 \* See Section F Introduction for more information.



### Electrical Data - Copelametic Small Refrigerant-Cooled Compressors

Model	Volts	PH	Max RLA	LRA	Resistance		Start Cap P/N	Run Cap P/N	Relay P/N	Part Type*	Protector P/N
					Start or Line to Line	Run or Line to WYE					
ERFA-031E-TAE	575	3	5.2	30	5.4	2.7					071-0090-16
ERFA-031L-TAC	208/230	3	12.4	82	0.837	0.42					071-0090-36
ERFA-031L-TAD	460	3	5.8	41	3.309	1.653					071-0090-10
ERFB-031E-CAB	230	1	17	86	2.41	0.595	014-0036-22	014-0064-14	040-0166-28	RP	071-0119-00
ERFB-031L-CAB	230	1	17	86	2.41	0.595	014-0036-22	014-0064-14	040-0166-28	RP	071-0119-00
ERJ1-0200-TAC	208/230	3	6.3	46	1.675	0.84					071-0090-00
ERJ1-0200-TAD	460	3	3.4	23	6.692	3.346					071-0090-08
ERJ1-0200-TAE	575	3	3.5	20	9.3	4.905					071-0090-15
ERJ1-020A-TAC	208/230	3	6.3	46	1.675	0.84					071-0090-00
ERJ1-020A-TAD	460	3	3.4	23	6.692	3.346					071-0090-08
ERJ2-0200-CAB	230	1	10.1	58	2.7	1.125	014-0036-22	014-0064-11	040-0166-20	RP	071-0103-02
ERJ2-0200-CAH	208	1	13.4	57.2	2.836	0.74	014-0036-22	014-0064-11	040-0166-20	RP	071-0099-02
ERJ2-020A-CAB	230	1	10.1	58	2.7	1.125	014-0036-22	014-0064-11	040-0166-20	RP	071-0103-02
MRA2-0500-TFC	208/230	3	NA	115	0.519	0.26					071-0086-38
MRA2-0500-TFD	460	3	NA	53	2.08	1.015					071-0086-17
MRA2-0500-TFE	575	3	NA	42	3.17	1.585					071-0086-29
MRA2-0500-TFU	200	3	NA	110	0.415	0.207					071-0086-42
MRA2-0506-CFB	230	1	NA	125	1.4	0.37	014-0006-14	014-0064-18	040-0166-23	RP	071-0476-01
MRA2-050A-CFB	230	1	27.5	125	1.4	0.37	014-0006-14	014-0064-18	040-0166-23	RP	071-0476-01
MRA2-050A-TFC	208/230	3	22	115	0.519	0.26					071-0086-38
MRA2-050A-TFD	460	3	8.6	53	2.08	1.015					071-0086-17
MRA2-050L-TFC	208/230	3	22	115	0.519	0.26					071-0086-38
MRA2-050L-TFD	460	3	8.6	53	2.08	1.015					071-0086-17

\* See Section F Introduction for more information.

FD35

### Electrical Data - Copelametic Small Refrigerant-Cooled Compressors

Model	Volts	PH	Max RLA	LRA	Resistance		Start Cap P/N	Run Cap P/N	Relay P/N	Part Type*	Protector P/N
					Start or Line to Line	Run or Line to WYE					
MRA8-0500-TFC	208/230	3	NA	115	0.519	0.26					071-0086-38
MRA8-0500-TFD	460	3	NA	53	2.08	1.015					071-0086-17
MRB1-0500-TFC	208/230	3	21.2	115	0.519	0.26					071-0086-38
MRB1-0500-TFD	460	3	12.1	53	2.08	1.015					071-0086-35
MRB1-0500-TFE	575	3	NA	42	3.17	1.585					071-0086-36
MRB1-050A-TFC	208/230	3	21.2	115	0.519	0.26					071-0086-38
MRB1-050A-TFD	460	3	12.1	53	2.08	1.015					071-0086-35
MRC1-0500-TFC	208/230	3	18.4	115	0.519	0.26					071-0086-38
MRC1-0500-TFD	460	3	9.2	53	2.08	1.015					071-0086-35
MRC8-0500-TFC	208/230	3	18.4	115	0.519	0.26					071-0086-38
MRC8-0500-TFD	460	3	9.2	53	2.08	1.015					071-0086-35
MRF2-0500-TFC	208/230	3	21	115	0.519	0.26					071-0086-38
MRF2-0500-TFD	460	3	8.6	53	2.08	1.015					071-0086-17
MRF2-0500-TFE	575	3	7.8	42	3.17	1.585					071-0086-29
MRF2-0506-CFB	230	1	25.2	125	1.4	0.37	014-0006-14	014-0064-18	040-0166-23	RP	071-0476-01
MRF2-050A-CFB	230	1	25.2	125	1.4	0.37	014-0006-14	014-0064-18	040-0166-23	RP	071-0476-01
MRF2-050A-TFC	208/230	3	21	115	0.519	0.26					071-0086-38
MRF2-050A-TFD	460	3	8.6	53	2.08	1.015					071-0086-17
MRF8-0500-TFC	208/230	3	21	115	0.519	0.26					071-0086-38
MRH4-0760-FSC	230	3	NA	130	0.82	0.41					071-0581-02
MRH4-0760-TF7	380	3	NA	82	1.208	0.604					071-0086-20
MRH4-0760-TFC	208/230	3	NA	164	0.338	0.169					071-0086-21
MRH4-0760-TFD	460	3	NA	82	1.351	0.675					071-0086-20

FD36 \* See Section F Introduction for more information.

### Electrical Data - Copelametic Small Refrigerant-Cooled Compressors

Model	Volts	PH	Max RLA	LRA	Resistance		Start Cap P/N	Run Cap P/N	Relay P/N	Part Type*	Protector P/N
					Start or Line to Line	Run or Line to WYE					
MRH4-0760-TFE	575	3	NA	63.8	2.16	1.08					071-0086-40
MRH4-076A-TFC	208/230	3	30.3	164	0.338	0.169					071-0086-21
MRH4-076A-TFD	460	3	13.5	82	1.351	0.675					071-0086-20
MRH4-076L-TFC	208/230	3	30.3	164	0.338	0.169					071-0086-21
MRH4-076L-TFD	460	3	13.5	82	1.351	0.675					071-0086-20
MRJ1-0500-TFU	200	3	NA	110	0.415	0.207					071-0086-42
NRA2-0310-TFU	200	3	NA	79.6	0.721	0.384					071-0086-41
NRA2-0500-TF7	380	3	NA	62.5	2.14	1.07					071-0086-14
NRA2-0500-TFC	208/230	3	NA	141	0.546	0.273					071-0086-39
NRA2-0500-TFD	460	3	NA	62.5	2.14	1.07					071-0086-14
NRA2-0500-TFE	575	3	NA	53.4	3.23	1.615					071-0086-17
NRA2-050A-TFC	208/230	3	19.2	141	0.546	0.273					071-0086-39
NRA2-050A-TFD	460	3	9.6	62.5	2.14	1.07					071-0086-14
NRA3-0500-TFC	208/230	3	NA	141	0.546	0.273					071-0086-39
NRA3-0500-TFD	460	3	NA	62.5	2.14	1.07					071-0086-14
NRA3-050L-TFC	208/230	3	19.2	141	0.546	0.273					071-0086-39
NRA3-050L-TFD	460	3	9.6	62.5	2.14	1.07					071-0086-14
NRB2-0310-TFC	208/230	3	12.9	82	0.9	0.47					071-0086-11
NRB2-0310-TFD	460	3	6.4	41	3.6	1.9					071-0086-37
NRB2-031A-TFC	208/230	3	12.9	82	0.9	0.47					071-0086-11
NRB2-031A-TFD	460	3	6.4	41	3.6	1.9					071-0086-37
NRB2-0400-TFC	208/230	3	21.9	141	0.514	0.257					071-0086-39
NRB2-0400-TFD	460	3	11.3	62.5	1.987	0.99					071-0086-14

\* See Section F Introduction for more information.

FD37

### Electrical Data - Copelametic Small Refrigerant-Cooled Compressors

Model	Volts	PH	Max RLA	LRA	Resistance		Start Cap P/N	Run Cap P/N	Relay P/N	Part Type*	Protector P/N
					Start or Line to Line	Run or Line to WYE					
NRB2-0400-TFE	575	3	9.2	53.4	3.23	1.615					071-0086-17
NRB2-040A-TFC	208/230	3	21.9	141	0.514	0.257					071-0086-39
NRB2-040A-TFD	460	3	11.3	62.5	1.987	0.99					071-0086-14
NRB2-040E-TFC	208/230	3	21.9	141	0.546	0.273					071-0086-39
NRB2-040E-TFD	460	3	9	62.5	1.987	0.99					071-0429-18
NRB2-040L-TFC	208/230	3	21.9	141	0.546	0.273					071-0086-39
NRB2-040L-TFD	460	3	9	62.5	1.987	0.99					071-0429-18
NRB3-0400-TFC	208/230	3	21.9	141	0.514	0.257					071-0086-39
NRB3-0400-TFD	460	3	11.3	62.5	1.987	0.99					071-0086-14
NRB3-040L-TFC	208/230	3	21.9	141	0.514	0.257					071-0086-39
NRB3-040L-TFD	460	3	11.3	62.5	1.987	0.99					071-0086-14
NRD1-0310-TFC	208/230	3	NA	82	0.9	0.47					071-0086-11
NRD1-0310-TFD	460	3	NA	41	3.6	1.9					071-0086-37
NRD1-0310-TFU	200	3	NA	79.6	0.721	0.384					071-0086-41
NRD1-031A-TFC	208/230	3	NA	82	0.9	0.47					071-0086-11
NRD1-031A-TFD	460	3	7.3	41	3.6	1.9					071-0086-37
NRD1-032E-TFC	208/230	3	16.3	82	0.9	0.47					071-0429-30
NRD1-032E-TFD	460	3	8.4	41	3.6	1.9					071-0429-31
NRD1-032L-TFC	208/230	3	16.3	82	0.9	0.47					071-0429-30
NRD1-032L-TFD	460	3	8.4	41	3.6	1.9					071-0429-31
NRD1-0406-CFB	230	1	23.6	115	2.32	0.417	014-0006-14	014-0064-14	040-0166-28	RP	071-0476-01
NRD1-040A-CFB	230	1	23.6	115	2.32	0.417	014-0006-14	014-0064-14	040-0166-28	RP	071-0476-01
NRD1-040E-CFB	230	1	27.7	115	2.32	0.417	014-0006-14	014-0064-14	040-0166-28	RP	071-0476-01

FD38 \* See Section F Introduction for more information.

### Electrical Data - Copelametic Small Refrigerant-Cooled Compressors

Model	Volts	PH	Max RLA	LRA	Resistance		Start Cap P/N	Run Cap P/N	Relay P/N	Part Type*	Protector P/N
					Start or Line to Line	Run or Line to WYE					
NRD1-040L-CFB	230	1	27.7	115	2.32	0.417	014-0006-14	014-0064-14	040-0166-28	RP	071-0476-01
NRD2-032E-TFC	208/230	3	16.3	82	0.9	0.47					071-0429-30
NRD2-032E-TFD	460	3	8.4	41	3.6	1.9					071-0429-31
NRM1-0500-TFC	208/230	3	24.3	141	0.546	0.273					071-0086-39
NRM1-0500-TFD	460	3	12.1	62.5	2.14	1.07					071-0086-14
NRM1-0500-TFE	575	3	9.2	53.4	3.23	1.615					071-0086-17
NRM1-050A-TFC	208/230	3	24.3	141	0.546	0.273					071-0086-39
NRM1-050A-TFD	460	3	12.1	62.5	2.14	1.07					071-0086-14
NRM1-050L-TFC	208/230	3	24.3	141	0.546	0.273					071-0086-39
NRM1-050L-TFD	460	3	12.1	62.5	2.14	1.07					071-0086-14
NRN2-0310-TFC	208/230	3	13	82	0.9	0.47					071-0086-11
NRN2-0310-TFD	460	3	6.5	41	3.6	1.9					071-0086-37
NRN2-031A-TFC	208/230	3	13	82	0.9	0.47					071-0086-11
NRN2-031A-TFD	460	3	6.4	41	3.6	1.9					071-0086-37

\* See Section F Introduction for more information.

FD39

### Electrical Data - Copelametic Large Refrigerant-Cooled Compressors

Model †‡	Volts	PH	Across the Line		Part Winding Start		Winding Resistance Line to Line (Ohms) †
			Max RLA	LRA	Max RLA	LRA	
3DA3A0710-ESX	200/220	3	25.7	167		58	0.36
3DA3A0710-ESX	380	3	15.6	96			1.08
3DA3A071E-ESX	200/220	3	31.8	167		58	0.36
3DA3A071E-ESX	380	3	18.9	96			1.08
3DA3A071L-ESX	200/220	3	31.8	167		58	0.36
3DA3A071L-ESX	380	3	18.9	96			1.08
3DB3A0750-ES8	200/220	3	29.2	167		58	0.36
3DB3A0750-ES8	380	3	16.4	96			1.08
3DB3A0910-ESX	220	3	38.1	228		74	0.279
3DB3A0910-ESX	380	3	20.4	132			0.837
3DB3A091E-ESX	220	3	47.4	228		74	0.279
3DB3A091E-ESX	380	3	27.7	132			0.837
3DB3A1000-ES8	200/220	3	48	228		74	0.279
3DB3A1000-ES8	380	3	27.4	132			0.837
3DB3F33K0-ES8	200/220	3	29.2	167		58	0.36
3DB3F33K0-ES8	380	3	16.4	96			1.08
3DB3R12M0-ES8	200/220	3	48	228		74	0.279
3DB3R12M0-ES8	380	3	27.4	132			0.837
3DP3A1000-ES8	200/220	3	48	228		74	0.279
3DP3A1000-ES8	380	3	27.4	132			0.837
3DP3R12M0-ES8	200/220	3	48	228		74	0.279
3DP3R12M0-ES8	380	3	27.4	132			0.837

† ‡ See Section F Introduction for more information.

FE1

### Electrical Data - Copelametic Large Refrigerant-Cooled Compressors

Model †‡	Volts	PH	Across the Line		Part Winding Start		Winding Resistance Line to Line (Ohms) †
			Max RLA	LRA	Max RLA	LRA	
3DR3A1000-ES8	200/220	3	41.7	228		74	0.279
3DR3A1000-ES8	380	3	24.1	132			0.837
3DS3A1000-ES8	200/220	3	47.1	228		74	0.279
3DS3A1000-ES8	380	3	25.7	132			0.837
3DS3A1210-ESX	220	3	42.1	228		74	0.279
3DS3A1210-ESX	380	3	24.1	132			0.837
3DS3A121E-ESX	220	3	53.4	228		74	0.279
3DS3A121E-ESX	380	3	31.2	132			0.837
3DS3A1500-ES8	200/220	3	57.6	316		108	0.191
3DS3A1500-ES8	380	3	32.9	180			0.573
3DS3F46K0-ES8	200/220	3	47.1	228		74	0.279
3DS3F46K0-ES8	380	3	25.7	132			0.837
3DS3R17M0-ES8	200/220	3	57.6	316		108	0.191
3DS3R17M0-ES8	380	3	32.9	180			0.573
3DT3A1000-ES8	200/220	3	47.1	228		74	0.279
3DT3A1000-ES8	380	3	25.7	132			0.837
3DT3A1500-ES8	200/220	3	57.6	316		108	0.191
3DT3A1500-ES8	380	3	32.9	180			0.573
3DT3R17M0-ES8	200/220	3	57.6	316		108	0.191
3DT3R17M0-ES8	380	3	32.9	180			0.573
4DA1A1000-FSD	460	3	25.7	110	12.9	66	1.02
4DA1A1000-TSE	575	3	20	106			1.6

† ‡ See Section F Introduction for more information.

FE2

### Electrical Data - Copelametic Large Refrigerant-Cooled Compressors

Model †‡	Volts	PH	Across the Line		Part Winding Start		Winding Resistance Line to Line (Ohms) †
			Max RLA	LRA	Max RLA	LRA	
4DA1A1000-TSK	208/230	3	53.6	240	26.8	140	0.259
4DA1A1000-TSK	460	3	26.8	120			1.036
4DA1A2000-FSD	460	3	32.1	140	16.1	84	0.757
4DA1A2000-TSE	575	3	28.6	135	14.3	81	2.2
4DA1A2000-TSK	208/230	3	70	308	35	188	0.174
4DA1A2000-TSK	460	3	35	154			0.696
4DA1A2000-TXK	208/230	3	NA	308	35	188	0.174
4DA1A2000-TXK	460	3	NA	154			0.696
4DA1R18M0-TSK	208/230	3	70	308	35	188	0.174
4DA1R18M0-TSK	460	3	35	154			0.696
4DA3A1000-FSD	460	3	20	115	10	70	1.012
4DA3A1000-TSE	575	3	17.4	106			1.6
4DA3A1000-TSK	208/230	3	42	240	21	140	0.259
4DA3A1000-TSK	460	3	21	120			1.036
4DA3A100E-FSD	460	3	20	115	10	70	1.012
4DA3A100E-TSE	575	3	17.4	106			1.6
4DA3A100E-TSK	208/230	3	42	240	21	140	0.259
4DA3A100E-TSK	460	3	21	120			1.036
4DA3A100L-FSD	460	3	20	115	10	70	1.012
4DA3A100L-TSE	575	3	17.4	106			1.6
4DA3A100L-TSK	208/230	3	42	240	21	140	0.259
4DA3A100L-TSK	460	3	21	120			1.036

† ‡ See Section F Introduction for more information.

FE3



### Electrical Data - Copelametic Large Refrigerant-Cooled Compressors

Model †‡	Volts	PH	Across the Line		Part Winding Start		Winding Resistance Line to Line (Ohms) †
			Max RLA	LRA	Max RLA	LRA	
4DA3A1010-TSE	575	3	17.4	106			1.6
4DA3A1010-TSK	208/230	3	42	220	22.6	134	0.244
4DA3A1010-TSK	460	3	21	110			0.976
4DA3A101E-TSE	575	3	17.4	106			1.6
4DA3A101E-TSK	208/230	3	45.6	220	22.6	134	0.244
4DA3A101E-TSK	460	3	22.8	110			0.976
4DA3A101L-TSE	575	3	17.4	106			1.6
4DA3A101L-TSK	208/230	3	45.6	220	22.6	134	0.244
4DA3A101L-TSK	460	3	22.8	110			0.976
4DA3A2000-FSD	460	3	33.6	173	16.8	104	0.603
4DA3A2000-FXD	460	3	NA	173		104	0.603
4DA3A2000-TSE	575	3	24.7	135	12.4	81	2.2
4DA3A2000-TSK	208/230	3	66.6	308	33	188	0.174
4DA3A2000-TSK	460	3	33.3	154			0.696
4DA3A2000-TXE	575	3	NA	135		81	1.1
4DA3A2000-TXK	208/230	3	NA	308	33	188	0.174
4DA3A2000-TXK	460	3	NA	154			0.696
4DA3A200E-FSD	460	3	33.6	173	16.8	104	0.603
4DA3A200E-TSE	575	3	24.7	135	12.4	81	2.2
4DA3A200E-TSK	208/230	3	82.9	308	33	188	0.174
4DA3A200E-TSK	460	3	41.4	154			0.696
4DA3A200L-FSD	460	3	33.6	173	16.8	104	0.603

† ‡ See Section F Introduction for more information.

FE4

### Electrical Data - Copelametic Large Refrigerant-Cooled Compressors

Model †‡	Volts	PH	Across the Line		Part Winding Start		Winding Resistance Line to Line (Ohms) †
			Max RLA	LRA	Max RLA	LRA	
4DA3A200L-TSE	575	3	24.7	135	12.4	81	2.2
4DA3A200L-TSK	208/230	3	82.9	308	33	188	0.174
4DA3A200L-TSK	460	3	41.4	154			0.696
4DA3F47K0-TSE	575	3	17.4	106			1.6
4DA3F47K0-TSK	208/230	3	42	220	22.6	134	0.244
4DA3F47K0-TSK	460	3	21	110			0.976
4DA3F47KE-TSE	575	3	17.4	106			1.6
4DA3F47KE-TSK	208/230	3	45.6	220	22.6	134	0.244
4DA3F47KE-TSK	460	3	22.8	110			0.976
4DA3F47KL-TSE	575	3	17.4	106			1.6
4DA3F47KL-TSK	208/230	3	45.6	220	22.6	134	0.244
4DA3F47KL-TSK	460	3	22.8	110			0.976
4DA3R12M0-FSD	460	3	20	115	10	70	1.012
4DA3R12ME-FSD	460	3	20	115	10	70	1.012
4DA3R12ME-TSK	208/230	3	42	240	21	140	0.259
4DA3R12ME-TSK	460	3	21	120			1.036
4DA3R18M0-FSD	460	3	33.6	173	16.8	104	0.603
4DA3R18M0-TSE	575	3	24.7	135	12.4	81	2.2
4DA3R18M0-TSK	208/230	3	66.6	308	33	188	0.174
4DA3R18M0-TSK	460	3	33.3	154			0.696
4DA3R18ME-FSD	460	3	33.6	173	16.8	104	0.603
4DA3R18ME-TSE	575	3	24.7	135	12.4	81	2.2

† ‡ See Section F Introduction for more information.

FE5

### Electrical Data - Copelametic Large Refrigerant-Cooled Compressors

Model †‡	Volts	PH	Across the Line		Part Winding Start		Winding Resistance Line to Line (Ohms) †
			Max RLA	LRA	Max RLA	LRA	
4DA3R18ME-TSK	208/230	3	82.9	308	33	188	0.174
4DA3R18ME-TSK	460	3	41.4	154			0.696
4DA3R18ML-FSD	460	3	33.6	173	16.8	104	0.603
4DA3R18ML-TSE	575	3	24.7	135	12.4	81	2.2
4DA3R18ML-TSK	208/230	3	82.9	308	33	188	0.174
4DA3R18ML-TSK	460	3	41.4	154			0.696
4DA3S13ME-TSK	208/230	3	57.1	278			0
4DA3S13ME-TSK	460	3	27.1	139			0.204
4DA3S13ML-TSK	208/230	3	57.1	278			0
4DA3S13ML-TSK	460	3	27.1	139			0.204
4DA5A1000-TSK	208/230	3	53.6	240	26.8	140	0.259
4DA5A1000-TSK	460	3	26.8	120			1.036
4DAGA1010-TSK	208/230	3	42	220	22.6	134	0.244
4DAGA1010-TSK	460	3	21	110			0.976
4DAJA2000-TSK	208/230	3	66.6	308	33	188	0.174
4DAJA2000-TSK	460	3	33.3	154			0.696
4DB3A2200-FSD	460	3	32.5	180	16.3	108	0.558
4DB3A2200-TSE	575	3	26.5	135	13.3	81	1.94
4DB3A2200-TSK	208/230	3	65.6	374	32.8	222	0.14
4DB3A2200-TSK	460	3	32.8	187			0.56
4DB3A220E-FSD	460	3	32.5	180	16.3	108	0.558
4DB3A220E-TSE	575	3	31.4	135	13.3	81	1.94

† ‡ See Section F Introduction for more information.

FE6

### Electrical Data - Copelametic Large Refrigerant-Cooled Compressors

Model †‡	Volts	PH	Across the Line		Part Winding Start		Winding Resistance Line to Line (Ohms) †
			Max RLA	LRA	Max RLA	LRA	
4DB3A220E-TSK	208/230	3	92.9	374	32.8	222	0.14
4DB3A220E-TSK	460	3	46.4	187			0.56
4DB3A220L-FSD	460	3	32.5	180	16.3	108	0.558
4DB3A220L-TSE	575	3	31.4	135	13.3	81	1.94
4DB3A220L-TSK	208/230	3	92.9	374	32.8	222	0.14
4DB3A220L-TSK	460	3	46.4	187			0.56
4DB3R20M0-FSD	460	3	32.5	180	16.3	108	0.558
4DB3R20M0-TSE	575	3	26.5	135	13.3	81	1.94
4DB3R20M0-TSK	208/230	3	65.6	374	32.8	222	0.14
4DB3R20M0-TSK	460	3	32.8	187			0.56
4DB3R20ME-FSD	460	3	32.5	180	16.3	108	0.558
4DB3R20ME-TSE	575	3	31.4	135	13.3	81	1.94
4DB3R20ME-TSK	208/230	3	92.9	374	32.8	222	0.14
4DB3R20ME-TSK	460	3	46.4	187			0.56
4DB3R20ML-FSD	460	3	32.5	180	16.3	108	0.558
4DB3R20ML-TSE	575	3	31.4	135	13.3	81	1.94
4DB3R20ML-TSK	208/230	3	92.9	374	32.8	222	0.14
4DB3R20ML-TSK	460	3	46.4	187			0.56
4DC3A2200-FSD	460	3	32.5	180	16.3	108	0.558
4DC3A2200-TSE	575	3	26.5	135	13.3	81	1.94
4DC3A2200-TSK	208/230	3	65.6	374	32.8	222	0.14
4DC3A2200-TSK	460	3	32.8	187			0.56

† ‡ See Section F Introduction for more information.

FE7

### Electrical Data - Copelametic Large Refrigerant-Cooled Compressors

Model †‡	Volts	PH	Across the Line		Part Winding Start		Winding Resistance Line to Line (Ohms) †
			Max RLA	LRA	Max RLA	LRA	
4DC3A220E-FSD	460	3	32.5	180	16.3	108	0.558
4DC3A220E-TSE	575	3	31.4	135	13.3	81	1.94
4DC3A220E-TSK	208/230	3	92.9	374	32.8	222	0.14
4DC3A220E-TSK	460	3	46.4	187			0.56
4DC3A220L-FSD	460	3	32.5	180	16.3	108	0.558
4DC3A220L-TSE	575	3	31.4	135	13.3	81	1.94
4DC3A220L-TSK	208/230	3	92.9	374	32.8	222	0.14
4DC3A220L-TSK	460	3	46.4	187			0.56
4DC3R20M0-FSD	460	3	32.5	180	16.3	108	0.558
4DC3R20M0-TSE	575	3	26.5	135	13.3	81	1.94
4DC3R20M0-TSK	208/230	3	65.6	374	32.8	222	0.14
4DC3R20M0-TSK	460	3	32.8	187			0.56
4DC3R20ME-FSD	460	3	32.5	180	16.3	108	0.558
4DC3R20ME-TSE	575	3	31.4	135	13.3	81	1.94
4DC3R20ME-TSK	208/230	3	92.9	374	32.8	222	0.14
4DC3R20ME-TSK	460	3	46.4	187			0.56
4DC3R20ML-FSD	460	3	32.5	180	16.3	108	0.558
4DC3R20ML-TSE	575	3	31.4	135	13.3	81	1.94
4DC3R20ML-TSK	208/230	3	92.9	374	32.8	222	0.14
4DC3R20ML-TSK	460	3	46.4	187			0.56
4DE1A1000-TSE	575	3	20	106			1.6
4DE1A1000-TSK	208/230	3	53.6	240	26.8	140	0.259

† ‡ See Section F Introduction for more information.

FE8

### Electrical Data - Copelametic Large Refrigerant-Cooled Compressors

Model †‡	Volts	PH	Across the Line		Part Winding Start		Winding Resistance Line to Line (Ohms) †
			Max RLA	LRA	Max RLA	LRA	
4DE1A1000-TSK	460	3	26.8	120			1.036
4DE1A2000-FSD	460	3	32.1	140	16.1	84	0.757
4DE1A2000-TSE	575	3	28.6	135	14.3	81	2.2
4DE1A2000-TSK	208/230	3	70	308	35	188	0.174
4DE1A2000-TSK	460	3	35	154			0.696
4DE1A2000-TXK	208/230	3	NA	308	35	188	0.174
4DE1A2000-TXK	460	3	NA	154			0.696
4DE1R18M0-FSD	460	3	32.1	140	16.1	84	0.757
4DE1R18M0-TSK	208/230	3	70	308	35	188	0.174
4DE1R18M0-TSK	460	3	35	154			0.696
4DE3A100E-TSK	208/230	3	42	240	21	140	0.259
4DE3A100E-TSK	460	3	21	120			1.036
4DE3A100L-TSK	208/230	3	42	240	21	140	0.259
4DE3A100L-TSK	460	3	21	120			1.036
4DE3A2000-FSD	460	3	33.6	173	16.8	104	0.603
4DE3A2000-FXD	460	3	NA	173		104	0.603
4DE3A2000-TSE	575	3	24.7	135	12.4	81	2.2
4DE3A2000-TSK	208/230	3	66.6	308	33	188	0.174
4DE3A2000-TSK	460	3	33.3	154			0.696
4DE3A2000-TXE	575	3	NA	135		81	1.1
4DE3A2000-TXK	208/230	3	NA	308	33	188	0.174
4DE3A2000-TXK	460	3	NA	154			0.696

† ‡ See Section F Introduction for more information.

FE9

### Electrical Data - Copelametic Large Refrigerant-Cooled Compressors

Model †‡	Volts	PH	Across the Line		Part Winding Start		Winding Resistance Line to Line (Ohms) †
			Max RLA	LRA	Max RLA	LRA	
4DE3A200E-FSD	460	3	33.6	173	16.8	104	0.603
4DE3A200E-TSE	575	3	24.7	135	12.4	81	2.2
4DE3A200E-TSK	208/230	3	82.9	308	33	188	0.174
4DE3A200E-TSK	460	3	41.4	154			0.696
4DE3A200L-FSD	460	3	33.6	173	16.8	104	0.603
4DE3A200L-TSE	575	3	24.7	135	12.4	81	2.2
4DE3A200L-TSK	208/230	3	82.9	308	33	188	0.174
4DE3A200L-TSK	460	3	41.4	154			0.696
4DE3R12ME-TSK	208/230	3	42	240	21	140	0.259
4DE3R12ME-TSK	460	3	21	120			1.036
4DE3R12ML-TSK	208/230	3	42	240	21	140	0.259
4DE3R12ML-TSK	460	3	21	120			1.036
4DE3R18M0-FSD	460	3	33.6	173	16.8	104	0.603
4DE3R18M0-TSE	575	3	24.7	135	12.4	81	2.2
4DE3R18M0-TSK	208/230	3	66.6	308	33	188	0.174
4DE3R18M0-TSK	460	3	33.3	154			0.696
4DE3R18ME-FSD	460	3	33.6	173	16.8	104	0.603
4DE3R18ME-TSE	575	3	24.7	135	12.4	81	2.2
4DE3R18ME-TSK	208/230	3	82.9	308	33	188	0.174
4DE3R18ME-TSK	460	3	41.4	154			0.696
4DE3R18ML-FSD	460	3	33.6	173	16.8	104	0.603
4DE3R18ML-TSE	575	3	24.7	135	12.4	81	2.2

† ‡ See Section F Introduction for more information.

FE10

### Electrical Data - Copelametic Large Refrigerant-Cooled Compressors

Model †‡	Volts	PH	Across the Line		Part Winding Start		Winding Resistance Line to Line (Ohms) †
			Max RLA	LRA	Max RLA	LRA	
4DE3R18ML-TSK	208/230	3	82.9	308	33	188	0.174
4DE3R18ML-TSK	460	3	41.4	154			0.696
4DE3S13ME-TSK	208/230	3	57.1	278			0
4DE3S13ME-TSK	460	3	27.1	139			0.204
4DE3S13ML-TSK	208/230	3	57.1	278			0
4DE3S13ML-TSK	460	3	27.1	139			0.204
4DE5A2000-TSK	208/230	3	70	308	35	188	0.174
4DE5A2000-TSK	460	3	35	154			0.696
4DE8A101E-TSK	208/230	3	45.6	220	22.6	134	0.244
4DE8A101E-TSK	460	3	22.8	110			0.976
4DE8A2000-FSD	460	3	33.6	173	16.8	104	0.603
4DE8A200E-TSK	208/230	3	58.7	308	33	188	0.174
4DE8A200E-TSK	460	3	29.4	154			0.696
4DE8F47KE-TSK	208/230	3	45.6	220	22.6	134	0.244
4DE8F47KE-TSK	460	3	22.8	110			0.976
4DH1A1500-FSD	460	3	32.9	136	16.5	81.6	0.84
4DH1A1500-TSE	575	3	24.3	113			0.97
4DH1A1500-TSK	208/230	3	61.4	278	30.7	170	0.208
4DH1A1500-TSK	460	3	30.7	139			0.832
4DH1A2500-ES8	200/220	3	99.3	438		142	0.345
4DH1A2500-ES8	380	3	58.6	251			0.115
4DH1A2500-FSD	460	3	46.4	195	23.2	117	0.575

† ‡ See Section F Introduction for more information.

FE11



### Electrical Data - Copelametic Large Refrigerant-Cooled Compressors

Model †‡	Volts	PH	Across the Line		Part Winding Start		Winding Resistance Line to Line (Ohms) †
			Max RLA	LRA	Max RLA	LRA	
4DH1A2500-FXD	460	3	NA	195		117	0.575
4DH1A2500-TSE	575	3	34.3	172	17.2	103	1.538
4DH1A2500-TSK	208/230	3	85.7	428	42.9	250	0.132
4DH1A2500-TSK	460	3	42.9	214			0.528
4DH1A2500-TXE	575	3	NA	172		103	0.769
4DH1A2500-TXK	208/230	3	NA	428		250	0.132
4DH1A2500-TXK	460	3	NA	214			0.528
4DH1R22M0-ES8	200/220	3	99.3	438		142	0.345
4DH1R22M0-ES8	380	3	58.6	251			0.115
4DH1R22M0-FSD	460	3	46.4	195	23.2	117	0.575
4DH1R22M0-TSK	208/230	3	85.7	428	42.9	250	0.132
4DH1R22M0-TSK	460	3	42.9	214			0.528
4DH3A150E-TSE	575	3	24.3	113			1.28
4DH3A150E-TSK	208/230	3	57.9	278	29	170	0.208
4DH3A150E-TSK	460	3	28.9	139			0.832
4DH3A150L-TSE	575	3	24.3	113			1.28
4DH3A150L-TSK	208/230	3	57.9	278	29	170	0.208
4DH3A150L-TSK	460	3	28.9	139			0.832
4DH3A2500-ES8	200/220	3	NA	438		142	0.345
4DH3A2500-ES8	380	3	NA	251			0.115
4DH3A2500-FSD	460	3	40.6	206	20.3	132	0.524
4DH3A2500-FXD	460	3	NA	206		132	0.524

† ‡ See Section F Introduction for more information.

FE12

### Electrical Data - Copelametic Large Refrigerant-Cooled Compressors

Model †‡	Volts	PH	Across the Line		Part Winding Start		Winding Resistance Line to Line (Ohms) †
			Max RLA	LRA	Max RLA	LRA	
4DH3A2500-TSE	575	3	34.4	172	17.2	103	1.538
4DH3A2500-TSK	208/230	3	82.1	428	41.1	250	0.132
4DH3A2500-TSK	460	3	41.1	214			0.528
4DH3A2500-TXE	575	3	NA	172		103	0.769
4DH3A2500-TXK	208/230	3	NA	428		250	0.132
4DH3A2500-TXK	460	3	NA	214			0.528
4DH3A250E-ES8	200/220	3	NA	438		142	0.345
4DH3A250E-ES8	380	3	NA	251			0.115
4DH3A250E-FSD	460	3	40.6	206	20.3	132	0.524
4DH3A250E-TSE	575	3	34.4	172	17.2	103	1.538
4DH3A250E-TSK	208/230	3	82.1	428	41.1	250	0.132
4DH3A250E-TSK	460	3	52.9	214			0.528
4DH3A250L-ES8	200/220	3	NA	438		142	0.345
4DH3A250L-ES8	380	3	NA	251			0.115
4DH3A250L-FSD	460	3	40.6	206	20.3	132	0.524
4DH3A250L-TSE	575	3	34.4	172	17.2	103	1.538
4DH3A250L-TSK	208/230	3	82.1	428	41.1	250	0.132
4DH3A250L-TSK	460	3	52.9	214			0.528
4DH3R16ME-TSK	208/230	3	57.9	278	29	170	0.208
4DH3R16ME-TSK	460	3	28.9	139			0.832
4DH3R16ML-TSK	208/230	3	57.9	278	29	170	0.208
4DH3R16ML-TSK	460	3	28.9	139			0.832

† ‡ See Section F Introduction for more information.

FE13

### Electrical Data - Copelametic Large Refrigerant-Cooled Compressors

Model †‡	Volts	PH	Across the Line		Part Winding Start		Winding Resistance Line to Line (Ohms) †
			Max RLA	LRA	Max RLA	LRA	
4DH3R22M0-ES8	200/220	3	NA	438		142	0.345
4DH3R22M0-ES8	380	3	NA	251			0.115
4DH3R22M0-FSD	460	3	40.6	206	20.3	132	0.524
4DH3R22M0-TSE	575	3	34.4	172	17.2	103	1.538
4DH3R22M0-TSK	208/230	3	82.1	428	41.1	250	0.132
4DH3R22M0-TSK	460	3	41.1	214			0.528
4DH3R22M0-TXE	575	3	NA	172		103	0.769
4DH3R22ME-FSD	460	3	40.6	206	20.3	132	0.524
4DH3R22ME-TSE	575	3	34.4	172	17.2	103	1.538
4DH3R22ME-TSK	208/230	3	82.1	428	41.1	250	0.132
4DH3R22ME-TSK	460	3	52.9	214			0.528
4DH3R22ML-FSD	460	3	40.6	206	20.3	132	0.524
4DH3R22ML-TSE	575	3	34.4	172	17.2	103	1.538
4DH3R22ML-TSK	208/230	3	82.1	428	41.1	250	0.132
4DH3R22ML-TSK	460	3	52.9	214			0.528
4DH3S16ME-TSK	208/230	3	65.7	308			0
4DH3S16ME-TSK	460	3	32.1	154			0.179
4DH3S16ML-TSK	208/230	3	NA	308			0
4DH3S16ML-TSK	460	3	NA	154			0.179
4DJ1A2000-FSD	460	3	32.9	173	16.5	104	0.603
4DJ1A2000-TSE	575	3	30	135	15	81	1.94
4DJ1A2000-TSK	208/230	3	71.4	346	35.7	208	0.142

† ‡ See Section F Introduction for more information.

FE14

### Electrical Data - Copelametic Large Refrigerant-Cooled Compressors

Model †‡	Volts	PH	Across the Line		Part Winding Start		Winding Resistance Line to Line (Ohms) †
			Max RLA	LRA	Max RLA	LRA	
4DJ1A2000-TSK	460	3	35.7	173			0.568
4DJ1A3000-ES8	200/220	3	123.6	500		164	0.294
4DJ1A3000-ES8	380	3	71.4	289			0.098
4DJ1A3000-FSD	460	3	59	235	29.5	141	0.45
4DJ1A3000-TSE	575	3	42.9	200	21.5	130	1.46
4DJ1A3000-TSK	208/230	3	117.9	470	59	292	0.111
4DJ1A3000-TSK	460	3	58.9	235			0.444
4DJ1A3000-TXE	575	3	NA	200		130	0.731
4DJ1A3000-TXK	208/230	3	NA	470		292	0.111
4DJ1A3000-TXK	460	3	NA	235			0.444
4DJ1R28M0-TSK	208/230	3	117.9	470	59	292	0.111
4DJ1R28M0-TSK	460	3	58.9	235			0.444
4DJ2A2000-TSK	208/230	3	71.4	346	35.7	208	0.142
4DJ2A2000-TSK	460	3	35.7	173			0.568
4DJ2A3000-TSK	208/230	3	117.9	470	59	292	0.111
4DJ2A3000-TSK	460	3	58.9	235			0.444
4DJ2R28M0-TSK	208/230	3	117.9	470	59	292	0.111
4DJ2R28M0-TSK	460	3	58.9	235			0.444
4DJ3A200E-TSE	575	3	30	135	15	81	1.94
4DJ3A200E-TSK	208/230	3	66	346	33	208	0.142
4DJ3A200E-TSK	460	3	33	173			0.568
4DJ3A200L-TSE	575	3	30	135	15	81	1.94

† ‡ See Section F Introduction for more information.

FE15

### Electrical Data - Copelametic Large Refrigerant-Cooled Compressors

Model †‡	Volts	PH	Across the Line		Part Winding Start		Winding Resistance Line to Line (Ohms) †
			Max RLA	LRA	Max RLA	LRA	
4DJ3A200L-TSK	208/230	3	66	346	33	208	0.142
4DJ3A200L-TSK	460	3	33	173			0.568
4DJ3A270E-TSK	208/230	3	94	470	47	292	0.111
4DJ3A270E-TSK	460	3	55	235			0.444
4DJ3A270L-TSK	208/230	3	94	470	47	292	0.111
4DJ3A270L-TSK	460	3	55	235			0.444
4DJ3A3000-FSD	460	3	45	235	22.5	141	0.45
4DJ3A3000-FXD	460	3	NA	235		141	0.45
4DJ3A3000-TSE	575	3	39.3	200	19.7	130	1.46
4DJ3A3000-TSK	208/230	3	94	470	47	292	0.111
4DJ3A3000-TSK	460	3	47	235			0.444
4DJ3A3000-TXE	575	3	NA	200		130	0.731
4DJ3A3000-TXK	208/230	3	NA	470		292	0.111
4DJ3A3000-TXK	460	3	NA	235			0.444
4DJ3A300E-FSD	460	3	45	235	22.5	141	0.45
4DJ3A300E-TSE	575	3	39.3	200	19.7	130	1.46
4DJ3A300E-TSK	208/230	3	94	470	47	292	0.111
4DJ3A300E-TSK	460	3	55	235			0.444
4DJ3A300L-FSD	460	3	45	235	22.5	141	0.45
4DJ3A300L-TSE	575	3	39.3	200	19.7	130	1.46
4DJ3A300L-TSK	208/230	3	94	470	47	292	0.111
4DJ3A300L-TSK	460	3	55	235			0.444

† ‡ See Section F Introduction for more information.

FE16

### Electrical Data - Copelametic Large Refrigerant-Cooled Compressors

Model †‡	Volts	PH	Across the Line		Part Winding Start		Winding Resistance Line to Line (Ohms) †
			Max RLA	LRA	Max RLA	LRA	
4DJ3R19ME-TSK	208/230	3	66	346	33	208	0.142
4DJ3R19ME-TSK	460	3	33	173			0.568
4DJ3R19ML-TSK	208/230	3	66	346	33	208	0.142
4DJ3R19ML-TSK	460	3	33	173			0.568
4DJ3R28M0-FSD	460	3	45	235	22.5	141	0.45
4DJ3R28M0-TSE	575	3	39.3	200	19.7	130	1.46
4DJ3R28M0-TSK	208/230	3	94	470	47	292	0.111
4DJ3R28M0-TSK	460	3	47	235			0.444
4DJ3R28ME-FSD	460	3	45	235	22.5	141	0.45
4DJ3R28ME-TSE	575	3	39.3	200	19.7	130	1.46
4DJ3R28ME-TSK	208/230	3	94	470	47	292	0.111
4DJ3R28ME-TSK	460	3	55	235			0.444
4DJ3R28ML-FSD	460	3	45	235	22.5	141	0.45
4DJ3R28ML-TSE	575	3	39.3	200	19.7	130	1.46
4DJ3R28ML-TSK	208/230	3	94	470	47	292	0.111
4DJ3R28ML-TSK	460	3	55	235			0.444
4DJ8A3000-TSK	208/230	3	94	470	47	292	0.111
4DJ8A3000-TSK	460	3	47	235			0.444
4DK1A1500-TSK	208/230	3	61.4	278	30.7	170	0.208
4DK1A1500-TSK	460	3	30.7	139			0.832
4DK1A2500-ES8	200/220	3	99.3	438		142	0.345
4DK1A2500-ES8	380	3	58.6	251			0.115

† ‡ See Section F Introduction for more information.

FE17

### Electrical Data - Copelametic Large Refrigerant-Cooled Compressors

Model †‡	Volts	PH	Across the Line		Part Winding Start		Winding Resistance Line to Line (Ohms) †
			Max RLA	LRA	Max RLA	LRA	
4DK1A2500-FSD	460	3	46.4	195	23.2	117	0.575
4DK1A2500-FXD	460	3	NA	195		117	0.575
4DK1A2500-TSE	575	3	34.3	172	17.2	103	1.538
4DK1A2500-TSK	208/230	3	85.7	428	42.9	250	0.132
4DK1A2500-TSK	460	3	42.9	214			0.528
4DK1A2500-TXE	575	3	NA	172		103	0.769
4DK1A2500-TXK	208/230	3	NA	428		250	0.132
4DK1A2500-TXK	460	3	NA	214			0.528
4DK1R22M0-FSD	460	3	46.4	195	23.2	117	0.575
4DK1R22M0-TSE	575	3	34.3	172	17.2	103	1.538
4DK1R22M0-TSK	208/230	3	85.7	428	42.9	250	0.132
4DK1R22M0-TSK	460	3	42.9	214			0.528
4DK3A150E-TSE	575	3	24.3	113			1.28
4DK3A150E-TSK	208/230	3	57.9	278	29	170	0.208
4DK3A150E-TSK	460	3	28.9	139			0.832
4DK3A150L-TSE	575	3	24.3	113			1.28
4DK3A150L-TSK	208/230	3	57.9	278	29	170	0.208
4DK3A150L-TSK	460	3	28.9	139			0.832
4DK3A2500-ES8	200/220	3	NA	438		142	0.345
4DK3A2500-ES8	380	3	NA	251			0.115
4DK3A2500-FSD	460	3	40.6	206	20.3	132	0.524
4DK3A2500-FXD	460	3	NA	206		132	0.524

† ‡ See Section F Introduction for more information.

FE18

### Electrical Data - Copelametic Large Refrigerant-Cooled Compressors

Model †‡	Volts	PH	Across the Line		Part Winding Start		Winding Resistance Line to Line (Ohms) †
			Max RLA	LRA	Max RLA	LRA	
4DK3A2500-TSE	575	3	34.4	172	17.2	103	1.538
4DK3A2500-TSK	208/230	3	82.1	428	41.1	250	0.132
4DK3A2500-TSK	460	3	41.1	214			0.528
4DK3A2500-TXE	575	3	NA	172		103	0.769
4DK3A2500-TXK	208/230	3	NA	428		250	0.132
4DK3A2500-TXK	460	3	NA	214			0.528
4DK3A250E-ES8	200/220	3	NA	438		142	0.345
4DK3A250E-ES8	380	3	NA	251			0.115
4DK3A250E-FSD	460	3	40.6	206	20.3	132	0.524
4DK3A250E-TSE	575	3	34.4	172	17.2	103	1.538
4DK3A250E-TSK	208/230	3	82.1	428	41.1	250	0.132
4DK3A250E-TSK	460	3	52.9	214			0.528
4DK3A250L-ES8	200/220	3	NA	438		142	0.345
4DK3A250L-ES8	380	3	NA	251			0.115
4DK3A250L-FSD	460	3	40.6	206	20.3	132	0.524
4DK3A250L-TSE	575	3	34.4	172	17.2	103	1.538
4DK3A250L-TSK	208/230	3	82.1	428	41.1	250	0.132
4DK3A250L-TSK	460	3	52.9	214			0.528
4DK3R16ME-TSK	208/230	3	57.9	278	29	170	0.208
4DK3R16ME-TSK	460	3	28.9	139			0.832
4DK3R22M0-ES8	200/220	3	NA	438		142	0.345
4DK3R22M0-ES8	380	3	NA	251			0.115

† ‡ See Section F Introduction for more information.

FE19



### Electrical Data - Copelametic Large Refrigerant-Cooled Compressors

Model †‡	Volts	PH	Across the Line		Part Winding Start		Winding Resistance Line to Line (Ohms) †
			Max RLA	LRA	Max RLA	LRA	
4DK3R22M0-FSD	460	3	40.6	206	20.3	132	0.524
4DK3R22M0-TSE	575	3	34.4	172	17.2	103	1.538
4DK3R22M0-TSK	208/230	3	82.1	428	41.1	250	0.132
4DK3R22M0-TSK	460	3	41.1	214			0.528
4DK3R22ME-FSD	460	3	40.6	206	20.3	132	0.524
4DK3R22ME-TSE	575	3	34.4	172	17.2	103	1.538
4DK3R22ME-TSK	208/230	3	82.1	428	41.1	250	0.132
4DK3R22ME-TSK	460	3	52.9	214			0.528
4DK3R22ML-FSD	460	3	40.6	206	20.3	132	0.524
4DK3R22ML-TSE	575	3	34.4	172	17.2	103	1.538
4DK3R22ML-TSK	208/230	3	82.1	428	41.1	250	0.132
4DK3R22ML-TSK	460	3	52.9	214			0.528
4DK3S16ME-TSK	208/230	3	65.7	308			0
4DK3S16ME-TSK	460	3	32.1	154			0.179
4DK3S16ML-TSK	208/230	3	NA	308			0
4DK3S16ML-TSK	460	3	NA	154			0.179
4DL1A1500-ES8	200/220	3	NA	295		107	0.546
4DL1A1500-ES8	380	3	NA	175			0.182
4DL1A1500-FSD	460	3	28.6	136	14.3	81.6	0.84
4DL1A1500-TSE	575	3	22.8	113			1.28
4DL1A1500-TSK	208/230	3	60	278	30	170	0.208
4DL1A1500-TSK	460	3	30	139			0.832

† ‡ See Section F Introduction for more information.

FE20

### Electrical Data - Copelametic Large Refrigerant-Cooled Compressors

Model †‡	Volts	PH	Across the Line		Part Winding Start		Winding Resistance Line to Line (Ohms) †
			Max RLA	LRA	Max RLA	LRA	
4DL1F63K0-FSD	460	3	28.6	136	14.3	81.6	0.84
4DL1F63K0-TSK	208/230	3	60	278	30	170	0.208
4DL1F63K0-TSK	460	3	30	139			0.832
4DL3A1500-ES8	200/220	3	NA	295		107	0.546
4DL3A1500-ES8	380	3	NA	175			0.182
4DL3A1500-FSD	460	3	24.5	136	12.3	81.6	0.84
4DL3A1500-TSE	575	3	20.9	113			1.28
4DL3A1500-TSK	208/230	3	52.6	278	26.3	170	0.208
4DL3A1500-TSK	460	3	26.3	139			0.832
4DL3A150E-FSD	460	3	24.5	136	12.3	81.6	0.84
4DL3A150E-TSE	575	3	20.9	113			1.28
4DL3A150E-TSK	208/230	3	52.6	278	26.3	170	0.208
4DL3A150E-TSK	460	3	26.3	139			0.832
4DL3A150L-FSD	460	3	24.5	136	12.3	81.6	0.84
4DL3A150L-TSE	575	3	20.9	113			1.28
4DL3A150L-TSK	208/230	3	52.6	278	26.3	170	0.208
4DL3A150L-TSK	460	3	26.3	139			0.832
4DL3F63K0-ES8	200/220	3	NA	295		107	0.546
4DL3F63K0-ES8	380	3	NA	175			0.182
4DL3F63K0-FSD	460	3	24.5	136	12.3	81.6	0.84
4DL3F63K0-TSE	575	3	20.9	113			1.28
4DL3F63K0-TSK	208/230	3	52.6	278	26.3	170	0.208

† ‡ See Section F Introduction for more information.

FE21

### Electrical Data - Copelametic Large Refrigerant-Cooled Compressors

Model † ¥	Volts	PH	Across the Line		Part Winding Start		Winding Resistance Line to Line (Ohms) †
			Max RLA	LRA	Max RLA	LRA	
4DL3F63K0-TSK	460	3	26.3	139			0.832
4DL3F63KE-FSD	460	3	24.5	136	12.3	81.6	0.84
4DL3F63KE-TSE	575	3	20.9	113			1.28
4DL3F63KE-TSK	208/230	3	52.6	278	26.3	170	0.208
4DL3F63KL-TSK	460	3	26.3	139			0.832
4DL3F63KL-FSD	460	3	24.5	136	12.3	81.6	0.84
4DL3F63KL-TSE	575	3	20.9	113			1.28
4DL3F63KL-TSK	208/230	3	52.6	278	26.3	170	0.208
4DL3F63KL-TSK	460	3	26.3	139			0.832
4DL8A1500-TSK	208/230	3	52.6	278	26.3	170	0.208
4DL8A1500-TSK	460	3	26.3	139			0.832
4DN1A1000-FSD	460	3	25.7	110	12.9	66	1.02
4DN1A1000-TSE	575	3	20	106			1.6
4DN1A1000-TSK	208/230	3	53.6	240	26.8	140	0.259
4DN1A1000-TSK	460	3	26.8	120			1.036
4DN3A1000-FSD	460	3	20	115	10	70	1.012
4DN3A1000-TSE	575	3	17.4	106			1.6
4DN3A1000-TSK	208/230	3	42	240	21	140	0.259
4DN3A1000-TSK	460	3	21	120			1.036
4DN3A100E-FSD	460	3	20	115	10	70	1.012
4DN3A100E-TSE	575	3	17.4	106			1.6
4DN3A100L-FSD	460	3	20	115	10	70	1.012

† † ¥ See Section F Introduction for more information.

FE22

### Electrical Data - Copelametic Large Refrigerant-Cooled Compressors

Model †‡	Volts	PH	Across the Line		Part Winding Start		Winding Resistance Line to Line (Ohms) †
			Max RLA	LRA	Max RLA	LRA	
4DN3A100L-TSE	575	3	17.4	106			1.6
4DN3A1010-TSE	575	3	17.4	106			1.6
4DN3A1010-TSK	208/230	3	42	220	22.6	134	0.244
4DN3A1010-TSK	460	3	21	110			0.976
4DN3A101E-TSE	575	3	17.4	106			1.6
4DN3A101E-TSK	208/230	3	45.6	220	22.6	134	0.244
4DN3A101E-TSK	460	3	22.8	110			0.976
4DN3A101L-TSE	575	3	17.4	106			1.6
4DN3A101L-TSK	208/230	3	45.6	220	22.6	134	0.244
4DN3A101L-TSK	460	3	22.8	110			0.976
4DN3F47K0-TSE	575	3	17.4	106			1.6
4DN3F47K0-TSK	208/230	3	42	220	22.6	134	0.244
4DN3F47K0-TSK	460	3	21	110			0.976
4DN3F47KE-TSE	575	3	17.4	106			1.6
4DN3F47KE-TSK	208/230	3	45.6	220	22.6	134	0.244
4DN3F47KE-TSK	460	3	22.8	110			0.976
4DN3F47KL-TSE	575	3	17.4	106			1.6
4DN3F47KL-TSK	208/230	3	45.6	220	22.6	134	0.244
4DN3F47KL-TSK	460	3	22.8	110			0.976
4DP1A1500-ES8	200/220	3	NA	295		107	0.546
4DP1A1500-ES8	380	3	NA	175			0.182
4DP1A1500-FSD	460	3	28.6	136	14.3	81.6	0.84

† ‡ See Section F Introduction for more information.

FE23

### Electrical Data - Copelametic Large Refrigerant-Cooled Compressors

Model †‡	Volts	PH	Across the Line		Part Winding Start		Winding Resistance Line to Line (Ohms) †
			Max RLA	LRA	Max RLA	LRA	
4DP1A1500-TSK	208/230	3	60	278	30	170	0.208
4DP1A1500-TSK	460	3	30	139			0.832
4DP3A1500-FSD	460	3	24.5	136	12.3	81.6	0.84
4DP3A1500-TSE	575	3	20.9	113			1.28
4DP3A1500-TSK	208/230	3	52.6	278	26.3	170	0.208
4DP3A1500-TSK	460	3	26.3	139			0.832
4DP3A150E-FSD	460	3	24.5	136	12.3	81.6	0.84
4DP3A150E-TSE	575	3	20.9	113			1.28
4DP3A150E-TSK	208/230	3	52.6	278	26.3	170	0.208
4DP3A150E-TSK	460	3	26.3	139			0.832
4DP3A150L-FSD	460	3	24.5	136	12.3	81.6	0.84
4DP3A150L-TSE	575	3	20.9	113			1.28
4DP3A150L-TSK	208/230	3	52.6	278	26.3	170	0.208
4DP3A150L-TSK	460	3	26.3	139			0.832
4DP3F63K0-FSD	460	3	24.5	136	12.3	81.6	0.84
4DP3F63K0-TSE	575	3	20.9	113			1.28
4DP3F63K0-TSK	208/230	3	52.6	278	26.3	170	0.208
4DP3F63K0-TSK	460	3	26.3	139			0.832
4DP3F63KE-FSD	460	3	24.5	136	12.3	81.6	0.84
4DP3F63KE-TSE	575	3	20.9	113			1.28
4DP3F63KE-TSK	208/230	3	52.6	278	26.3	170	0.208
4DP3F63KE-TSK	460	3	26.3	139			0.832

† ‡ See Section F Introduction for more information.

FE24

### Electrical Data - Copelametic Large Refrigerant-Cooled Compressors

Model †‡	Volts	PH	Across the Line		Part Winding Start		Winding Resistance Line to Line (Ohms) †
			Max RLA	LRA	Max RLA	LRA	
4DP3F63KL-FSD	460	3	24.5	136	12.3	81.6	0.84
4DP3F63KL-TSE	575	3	20.9	113			1.28
4DP3F63KL-TSK	208/230	3	52.6	278	26.3	170	0.208
4DP3F63KL-TSK	460	3	26.3	139			0.832
4DP8A1500-TSK	208/230	3	52.6	278	26.3	170	0.208
4DP8A1500-TSK	460	3	26.3	139			0.832
4DP8A150E-TSK	208/230	3	52.6	278	26.3	170	0.208
4DP8A150E-TSK	460	3	26.3	139			0.832
4DP8A150L-TSK	208/230	3	52.6	278	26.3	170	0.208
4DP8A150L-TSK	460	3	26.3	139			0.832
4DP8F63KE-TSK	208/230	3	52.6	278	26.3	170	0.208
4DP8F63KE-TSK	460	3	26.3	139			0.832
4DR1A2000-TSE	575	3	30	135	15	81	1.94
4DR1A2000-TSK	208/230	3	71.4	346	35.7	208	0.142
4DR1A2000-TSK	460	3	35.7	173			0.568
4DR1A3000-ES8	200/220	3	123.6	500		164	0.294
4DR1A3000-ES8	380	3	71.4	289			0.098
4DR1A3000-FSD	460	3	59	235	29.5	141	0.45
4DR1A3000-FXD	460	3	NA	235		141	0.45
4DR1A3000-TSE	575	3	42.9	200	21.5	130	1.46
4DR1A3000-TSK	208/230	3	117.9	470	59	292	0.111
4DR1A3000-TSK	460	3	58.9	235			0.444

† ‡ See Section F Introduction for more information.

FE25

### Electrical Data - Copelametic Large Refrigerant-Cooled Compressors

Model †‡	Volts	PH	Across the Line		Part Winding Start		Winding Resistance Line to Line (Ohms) †
			Max RLA	LRA	Max RLA	LRA	
4DR1A3000-TXE	575	3	NA	200		130	0.731
4DR1A3000-TXK	208/230	3	NA	470		292	0.111
4DR1A3000-TXK	460	3	NA	235			0.444
4DR1R28M0-FSD	460	3	59	235	29.5	141	0.45
4DR1R28M0-TSE	575	3	42.9	200	21.5	130	1.46
4DR1R28M0-TSK	208/230	3	117.9	470	59	292	0.111
4DR1R28M0-TSK	460	3	58.9	235			0.444
4DR3A200E-TSE	575	3	30	135	15	81	1.94
4DR3A200E-TSK	208/230	3	66	346	33	208	0.142
4DR3A200E-TSK	460	3	33	173			0.568
4DR3A200L-TSE	575	3	30	135	15	81	1.94
4DR3A200L-TSK	208/230	3	66	346	33	208	0.142
4DR3A200L-TSK	460	3	33	173			0.568
4DR3A270E-TSK	208/230	3	94	470	47	292	0.111
4DR3A270E-TSK	460	3	55	235			0.444
4DR3A270L-TSK	208/230	3	94	470	47	292	0.111
4DR3A270L-TSK	460	3	55	235			0.444
4DR3A3000-ES8	380	3	71.4	289			0.098
4DR3A3000-FSD	460	3	45	235	22.5	141	0.45
4DR3A3000-FXD	460	3	NA	235		141	0.45
4DR3A3000-TSE	575	3	39.3	200	19.7	130	1.46
4DR3A3000-TSK	208/230	3	94	470	47	292	0.111

† ‡ See Section F Introduction for more information.

FE26

### Electrical Data - Copelametic Large Refrigerant-Cooled Compressors

Model †‡	Volts	PH	Across the Line		Part Winding Start		Winding Resistance Line to Line (Ohms) †
			Max RLA	LRA	Max RLA	LRA	
4DR3A3000-TSK	460	3	47	235			0.444
4DR3A3000-TXE	575	3	NA	200		130	0.731
4DR3A3000-TXK	208/230	3	NA	470		292	0.111
4DR3A3000-TXK	460	3	NA	235			0.444
4DR3A300E-FSD	460	3	45	235	22.5	141	0.45
4DR3A300E-TSE	575	3	39.3	200	19.7	130	1.46
4DR3A300E-TSK	208/230	3	94	470	47	292	0.111
4DR3A300E-TSK	460	3	55	235			0.444
4DR3A300L-FSD	460	3	45	235	22.5	141	0.45
4DR3A300L-TSE	575	3	39.3	200	19.7	130	1.46
4DR3A300L-TSK	208/230	3	94	470	47	292	0.111
4DR3A300L-TSK	460	3	55	235			0.444
4DR3R19ME-TSK	208/230	3	66	346	33	208	0.142
4DR3R19ME-TSK	460	3	33	173			0.568
4DR3R28M0-ES8	380	3	71.4	289			0.098
4DR3R28M0-FSD	460	3	45	235	22.5	141	0.45
4DR3R28M0-TSE	575	3	39.3	200	19.7	130	1.46
4DR3R28M0-TSK	208/230	3	94	470	47	292	0.111
4DR3R28M0-TSK	460	3	47	235			0.444
4DR3R28ME-FSD	460	3	45	235	22.5	141	0.45
4DR3R28ME-TSE	575	3	39.3	200	19.7	130	1.46
4DR3R28ME-TSK	208/230	3	94	470	47	292	0.111

† ‡ See Section F Introduction for more information.

FE27



### Electrical Data - Copelametic Large Refrigerant-Cooled Compressors

Model †‡	Volts	PH	Across the Line		Part Winding Start		Winding Resistance Line to Line (Ohms) †
			Max RLA	LRA	Max RLA	LRA	
4DR3R28ME-TSK	460	3	55	235			0.444
4DR3R28ML-FSD	460	3	45	235	22.5	141	0.45
4DR3R28ML-TSE	575	3	39.3	200	19.7	130	1.46
4DR3R28ML-TSK	208/230	3	94	470	47	292	0.111
4DR3R28ML-TSK	460	3	55	235			0.444
4DR8A200E-TSK	208/230	3	66	346	33	208	0.142
4DR8A200E-TSK	460	3	33	173			0.568
4DS1A2200-FSD	460	3	32.9	180	16.5	108	0.558
4DS1A2200-TSE	575	3	28.6	135	14.3	81	1.94
4DS1A2200-TSK	208/230	3	71.4	374	35.7	222	0.14
4DS1A2200-TSK	460	3	35.7	187			0.56
4DS3A2200-ES8	200/220	3	68.9	405		134	0.375
4DS3A2200-ES8	380	3	40	235			0.125
4DS3A2200-FSD	460	3	33.9	180	17	108	0.558
4DS3A2200-TSE	575	3	24.1	135	12.1	81	1.94
4DS3A2200-TSK	208/230	3	66	374	33	222	0.14
4DS3A2200-TSK	460	3	33	187			0.56
4DS3A220E-FSD	460	3	33.9	180	17	108	0.558
4DS3A220E-TSE	575	3	24.1	135	12.1	81	1.94
4DS3A220E-TSK	208/230	3	66	374	33	222	0.14
4DS3A220E-TSK	460	3	33	187			0.56
4DS3A220L-FSD	460	3	33.9	180	17	108	0.558

† ‡ See Section F Introduction for more information.

FE28

### Electrical Data - Copelametic Large Refrigerant-Cooled Compressors

Model †‡	Volts	PH	Across the Line		Part Winding Start		Winding Resistance Line to Line (Ohms) †
			Max RLA	LRA	Max RLA	LRA	
4DS3A220L-TSE	575	3	24.1	135	12.1	81	1.94
4DS3A220L-TSK	208/230	3	66	374	33	222	0.14
4DS3A220L-TSK	460	3	33	187			0.56
4DS3F76K0-FSD	460	3	33.9	180	17	108	0.558
4DS3F76K0-TSE	575	3	24.1	135	12.1	81	1.94
4DS3F76K0-TSK	208/230	3	66	374	33	222	0.14
4DS3F76K0-TSK	460	3	33	187			0.56
4DS3F76KE-FSD	460	3	33.9	180	17	108	0.558
4DS3F76KE-TSE	575	3	24.1	135	12.1	81	1.94
4DS3F76KE-TSK	208/230	3	66	374	33	222	0.14
4DS3F76KE-TSK	460	3	33	187			0.56
4DS3F76KL-FSD	460	3	33.9	180	17	108	0.558
4DS3F76KL-TSE	575	3	24.1	135	12.1	81	1.94
4DS3F76KL-TSK	208/230	3	66	374	33	222	0.14
4DS3F76KL-TSK	460	3	33	187			0.56
4DT1A2200-FSD	460	3	32.9	180	16.5	108	0.558
4DT1A2200-TSE	575	3	28.6	135	14.3	81	1.94
4DT1A2200-TSK	208/230	3	71.4	374	35.7	222	0.14
4DT1A2200-TSK	460	3	35.7	187			0.56
4DT1F76K0-TSK	208/230	3	71.4	374	35.7	222	0.14
4DT1F76K0-TSK	460	3	35.7	187			0.56
4DT3A2200-ES8	200/220	3	68.9	405		134	0.375

† ‡ See Section F Introduction for more information.

FE29

### Electrical Data - Copelametic Large Refrigerant-Cooled Compressors

Model †‡	Volts	PH	Across the Line		Part Winding Start		Winding Resistance Line to Line (Ohms) †
			Max RLA	LRA	Max RLA	LRA	
4DT3A2200-ES8	380	3	40	235			0.125
4DT3A2200-FSD	460	3	33.9	180	17	108	0.558
4DT3A2200-TSE	575	3	24.1	135	12.1	81	1.94
4DT3A2200-TSK	208/230	3	66	374	33	222	0.14
4DT3A2200-TSK	460	3	33	187			0.56
4DT3A220E-FSD	460	3	33.9	180	17	108	0.558
4DT3A220E-TSE	575	3	24.1	135	12.1	81	1.94
4DT3A220E-TSK	208/230	3	66	374	33	222	0.14
4DT3A220E-TSK	460	3	33	187			0.56
4DT3A220L-FSD	460	3	33.9	180	17	108	0.558
4DT3A220L-TSE	575	3	24.1	135	12.1	81	1.94
4DT3A220L-TSK	208/230	3	66	374	33	222	0.14
4DT3A220L-TSK	460	3	33	187			0.56
4DT3A2510-ESX	220	3	72.1	405		134	0.375
4DT3A2510-ESX	380	3	41.9	235			0.125
4DT3A251E-ESX	220	3	89.3	405		134	0.375
4DT3A251E-ESX	380	3	49.6	235			0.125
4DT3A251L-ESX	220	3	89.3	405		134	0.375
4DT3A251L-ESX	380	3	49.6	235			0.125
4DT3F76K0-ES8	200/220	3	68.9	405		134	0.375
4DT3F76K0-ES8	380	3	40	235			0.125
4DT3F76K0-FSD	460	3	33.9	180	17	108	0.558

† ‡ See Section F Introduction for more information.

FE30

### Electrical Data - Copelametic Large Refrigerant-Cooled Compressors

Model †‡	Volts	PH	Across the Line		Part Winding Start		Winding Resistance Line to Line (Ohms) †
			Max RLA	LRA	Max RLA	LRA	
4DT3F76K0-TSE	575	3	24.1	135	12.1	81	1.94
4DT3F76K0-TSK	208/230	3	66	374	33	222	0.14
4DT3F76K0-TSK	460	3	33	187			0.56
4DT3F76KE-FSD	460	3	33.9	180	17	108	0.558
4DT3F76KE-TSE	575	3	24.1	135	12.1	81	1.94
4DT3F76KE-TSK	208/230	3	66	374	33	222	0.14
4DT3F76KE-TSK	460	3	33	187			0.56
4DT3F76KL-FSD	460	3	33.9	180	17	108	0.558
4DT3F76KL-TSE	575	3	24.1	135	12.1	81	1.94
4DT3F76KL-TSK	208/230	3	66	374	33	222	0.14
4DT3F76KL-TSK	460	3	33	187			0.56
4DT8A220E-TSE	575	3	24.1	135	12.1	81	1.94
4RA3-1000-TSE	575	3	19.8	106			1.6
4RA3-1000-TSK	208/230	3	54.9	240	27.4	140	0.259
4RA3-1000-TSK	460	3	27.4	120			1.036
4RA3-100A-TSK	208/230	3	54.9	240	27.4	140	0.259
4RA3-100A-TSK	460	3	27.4	120			1.036
4RA3-100L-TSK	208/230	3	54.9	240	27.4	140	0.259
4RA3-100L-TSK	460	3	27.4	120			1.036
4RA3-2000-ES8	200/220	3	68.4	335		113	0.483
4RA3-2000-ES8	380	3	38.9	189			0.161
4RA3-2000-FSD	460	3	32.4	135	16.2	82	0.757

† ‡ See Section F Introduction for more information.

FE31

### Electrical Data - Copelametic Large Refrigerant-Cooled Compressors

Model †‡	Volts	PH	Across the Line		Part Winding Start		Winding Resistance Line to Line (Ohms) †
			Max RLA	LRA	Max RLA	LRA	
4RA3-2000-TSE	575	3	29.2	135	14.6	74	2.2
4RA3-2000-TSK	208/230	3	71.4	308	35.7	188	0.173
4RA3-2000-TSK	460	3	35.7	154			0.69
4RA3-200A-TSK	208/230	3	71.4	308	35.7	188	0.173
4RA3-200A-TSK	460	3	35.7	154			0.69
4RA4-1000-TSE	575	3	19.8	106			1.6
4RA4-1000-TSK	208/230	3	54.9	240	27.4	140	0.259
4RA4-1000-TSK	460	3	27.4	120			1.036
4RA4-2000-TSE	575	3	29.2	135	14.6	74	2.2
4RA4-2000-TSK	208/230	3	71.4	308	35.7	188	0.173
4RA4-2000-TSK	460	3	35.7	154			0.69
4RA4-200A-TSK	208/230	3	71.4	308	35.7	188	0.173
4RA4-200A-TSK	460	3	35.7	154			0.69
4RA4-200L-TSK	208/230	3	71.4	308	35.7	188	0.173
4RA4-200L-TSK	460	3	35.7	154			0.69
4RE2-1000-TSE	575	3	19.8	106			1.6
4RE2-1000-TSK	208/230	3	54.9	240	27.4	140	0.259
4RE2-1000-TSK	460	3	27.4	120			1.036
4RE2-2000-ES8	200/220	3	68.4	335		113	0.483
4RE2-2000-ES8	380	3	38.9	189			0.161
4RE2-2000-FSD	460	3	32.4	135	16.2	82	0.757
4RE2-2000-TSE	575	3	29.2	135	14.6	74	2.2

† ‡ See Section F Introduction for more information.

FE32

### Electrical Data - Copelametic Large Refrigerant-Cooled Compressors

Model †‡	Volts	PH	Across the Line		Part Winding Start		Winding Resistance Line to Line (Ohms) †
			Max RLA	LRA	Max RLA	LRA	
4RE2-2000-TSK	208/230	3	71.4	308	35.7	188	0.173
4RE2-2000-TSK	460	3	35.7	154			0.69
4RE2-200A-FSD	460	3	32.4	135	16.2	82	0.757
4RE2-200A-TSK	208/230	3	71.4	308	35.7	188	0.173
4RE2-200A-TSK	460	3	35.7	154			0.69
4RE4-2000-TSK	208/230	3	71.4	308	35.7	188	0.173
4RE4-2000-TSK	460	3	35.7	154			0.69
4RE5-2000-TSK	208/230	3	71.4	308	35.7	188	0.173
4RE5-2000-TSK	460	3	35.7	154			0.69
4RH1-1500-TSE	575	3	24.1	113			1.255
4RH1-1500-TSK	208/230	3	63	278	31.5	170	0.208
4RH1-1500-TSK	460	3	31.5	139			0.832
4RH1-150A-TSK	208/230	3	63	278	31.5	170	0.208
4RH1-150A-TSK	460	3	31.5	139			0.832
4RH1-2500-ES8	200/220	3	99.1	438		142	0.345
4RH1-2500-ES8	380	3	59.9	251			0.115
4RH1-2500-FSD	460	3	45	165	22.5	100	0.575
4RH1-2500-TSE	575	3	34.9	160	17.4	113	1.76
4RH1-2500-TSK	208/230	3	88.6	428	44.3	250	0.132
4RH1-2500-TSK	460	3	44.3	214			0.528
4RH1-250A-FSD	460	3	45	165	22.5	100	0.575
4RH1-250A-TSK	208/230	3	88.6	428	44.3	250	0.132

† ‡ See Section F Introduction for more information.

FE33

### Electrical Data - Copelametic Large Refrigerant-Cooled Compressors

Model †‡	Volts	PH	Across the Line		Part Winding Start		Winding Resistance Line to Line (Ohms) †
			Max RLA	LRA	Max RLA	LRA	
4RH1-250A-TSK	460	3	44.3	214			0.528
4RH1-250L-TSK	208/230	3	88.6	428	44.3	250	0.132
4RH1-250L-TSK	460	3	44.3	214			0.528
4RH2-1500-TSK	208/230	3	63	278	31.5	170	0.208
4RH2-1500-TSK	460	3	31.5	139			0.832
4RH5-1500-TSK	208/230	3	63	278	31.5	170	0.208
4RH5-1500-TSK	460	3	31.5	139			0.832
4RJ1-3000-ES8	200/220	3	119.3	500		164	0.294
4RJ1-3000-ES8	380	3	68.4	289			0.098
4RJ1-3000-FSD	460	3	59	200	29.5	121	0.475
4RJ1-3000-TSE	575	3	42.1	200	21.1	130	1.46
4RJ1-3000-TSK	208/230	3	96.4	470	51	292	0.108
4RJ1-3000-TSK	460	3	50.7	235			0.43
4RJ1-300A-FSD	460	3	59	200	29.5	121	0.475
4RJ1-300A-TSK	208/230	3	96.4	470	51	292	0.108
4RJ1-300A-TSK	460	3	50.7	235			0.43
4RJ2-3000-ES8	200/220	3	119.3	500		164	0.294
4RJ2-3000-ES8	380	3	68.4	289			0.098
4RJ2-3000-FSD	460	3	59	200	29.5	121	0.475
4RJ2-3000-TSE	575	3	42.1	200	21.1	130	1.46
4RJ2-3000-TSK	208/230	3	96.4	470	51	292	0.108
4RJ2-3000-TSK	460	3	50.7	235			0.43

† ‡ See Section F Introduction for more information.

FE34

### Electrical Data - Copelametic Large Refrigerant-Cooled Compressors

Model † ¥	Volts	PH	Across the Line		Part Winding Start		Winding Resistance Line to Line (Ohms) †
			Max RLA	LRA	Max RLA	LRA	
4RJ2-300A-TSK	208/230	3	96.4	470	51	292	0.108
4RJ2-300A-TSK	460	3	50.7	235			0.43
4RK2-1500-TSE	575	3	24.1	113			1.255
4RK2-1500-TSK	208/230	3	63	278	31.5	170	0.208
4RK2-1500-TSK	460	3	31.5	139			0.832
4RK2-2500-ES8	200/220	3	102.5	438		142	0.345
4RK2-2500-ES8	380	3	59.9	251			0.115
4RK2-2500-FSD	460	3	45	165	22.5	100	0.575
4RK2-2500-TSE	575	3	34.9	160	17.4	113	1.76
4RK2-2500-TSK	208/230	3	88.6	428	44.3	250	0.132
4RK2-2500-TSK	460	3	44.3	214			0.528
4RK2-250A-FSD	460	3	45	165	22.5	100	0.575
4RK2-250A-TSE	575	3	34.9	160	17.4	113	1.76
4RK2-250A-TSK	208/230	3	88.6	428	44.3	250	0.132
4RK2-250A-TSK	460	3	44.3	214			0.528
4RK5-2500-TSK	208/230	3	88.6	428	44.3	250	0.132
4RK5-2500-TSK	460	3	44.3	214			0.528
4RL1-1500-TSE	575	3	24.1	113			1.255
4RL1-1500-TSK	208/230	3	62.6	278	31.3	170	0.208
4RL1-1500-TSK	460	3	31.4	139			0.832
4RL1-150A-TSK	208/230	3	62.6	278	31.3	170	0.208
4RL1-150A-TSK	460	3	31.4	139			0.832

† † ¥ See Section F Introduction for more information.

FE35



### Electrical Data - Copelametic Large Refrigerant-Cooled Compressors

Model †‡	Volts	PH	Across the Line		Part Winding Start		Winding Resistance Line to Line (Ohms) †
			Max RLA	LRA	Max RLA	LRA	
4RL1-1900-TSU	200	3	NA	350	32.5	205	0.133
4RL2-1500-TSE	575	3	24.1	113			1.255
4RL2-1500-TSK	208/230	3	62.6	278	31.3	170	0.208
4RL2-1500-TSK	460	3	31.4	139			0.832
4RL2-150A-TSK	208/230	3	62.6	278	31.3	170	0.208
4RL2-150A-TSK	460	3	31.4	139			0.832
4RL5-1900-TSU	200	3	NA	350	32.5	205	0.133
4RR1-3000-ES8	200/220	3	119.3	500		164	0.294
4RR1-3000-ES8	380	3	68.4	289			0.098
4RR1-3000-FSD	460	3	59	200	29.5	121	0.475
4RR1-3000-TSE	575	3	42.1	200	21.1	130	1.46
4RR1-3000-TSK	208/230	3	101.4	470	51	292	0.108
4RR1-3000-TSK	460	3	50.7	235			0.43
4RR1-300A-FSD	460	3	59	200	29.5	121	0.475
4RR1-300A-TSK	208/230	3	101.4	470	51	292	0.108
4RR1-300A-TSK	460	3	50.7	235			0.43
4RR2-3000-ES8	200/220	3	119.3	500		164	0.294
4RR2-3000-ES8	380	3	68.4	289			0.098
4RR2-3000-FSD	460	3	59	200	29.5	121	0.475
4RR2-3000-TSE	575	3	42.1	200	21.1	130	1.46
4RR2-3000-TSK	208/230	3	101.4	470	51	292	0.108
4RR2-3000-TSK	460	3	50.7	235			0.43

† ‡ See Section F Introduction for more information.

FE36

### Electrical Data - Copelametic Large Refrigerant-Cooled Compressors

Model †‡	Volts	PH	Across the Line		Part Winding Start		Winding Resistance Line to Line (Ohms) †
			Max RLA	LRA	Max RLA	LRA	
4RR2-300A-TSK	208/230	3	101.4	470	51	292	0.108
4RR2-300A-TSK	460	3	50.7	235			0.43
6DB3A3000-FSD	460	3	50	260	25	156	0.39
6DB3A3000-TSE	575	3	40	230	20	138	1.16
6DB3A3000-TSK	208/230	3	105	565	52.5	340	0.087
6DB3A3000-TSK	460	3	52.5	283			0.348
6DB3A300E-FSD	460	3	50	260	25	156	0.39
6DB3A300E-TSE	575	3	40	230	20	138	1.16
6DB3A300E-TSK	208/230	3	134.3	565	52.5	340	0.087
6DB3A300E-TSK	460	3	67.1	283			0.348
6DB3A300L-FSD	460	3	50	260	25	156	0.39
6DB3A300L-TSE	575	3	40	230	20	138	1.16
6DB3A300L-TSK	208/230	3	134.3	565	52.5	340	0.087
6DB3A300L-TSK	460	3	67.1	283			0.348
6DB3R32M0-FSD	460	3	50	260	25	156	0.39
6DB3R32M0-TSE	575	3	40	230	20	138	1.16
6DB3R32M0-TSK	208/230	3	105	565	52.5	340	0.087
6DB3R32M0-TSK	460	3	52.5	283			0.348
6DB3R32ME-FSD	460	3	50	260	25	156	0.39
6DB3R32ME-TSE	575	3	40	230	20	138	1.16
6DB3R32ME-TSK	208/230	3	134.3	565	52.5	340	0.087
6DB3R32ME-TSK	460	3	67.1	283			0.348

† ‡ See Section F Introduction for more information.

FE37

### Electrical Data - Copelametic Large Refrigerant-Cooled Compressors

Model †‡	Volts	PH	Across the Line		Part Winding Start		Winding Resistance Line to Line (Ohms) †
			Max RLA	LRA	Max RLA	LRA	
6DB3R32ML-FSD	460	3	50	260	25	156	0.39
6DB3R32ML-TSE	575	3	40	230	20	138	1.16
6DB3R32ML-TSK	208/230	3	134.3	565	52.5	340	0.087
6DB3R32ML-TSK	460	3	67.1	283			0.348
6DC1A2700-TSE	575	3	35	172	17.5	103	1.538
6DC1A2700-TSK	208/230	3	89.3	450	44.7	263	0.114
6DC1A2700-TSK	460	3	44.6	225			0.456
6DC3A2700-ES8	200/220	3	82.5	445		141	0.336
6DC3A2700-ES8	380	3	47.9	260			0.112
6DC3A2700-FSD	460	3	41.6	218	20.8	131	0.457
6DC3A2700-TSE	575	3	32.5	172	16.3	103	1.538
6DC3A2700-TSK	208/230	3	80.7	450	40.4	263	0.114
6DC3A2700-TSK	460	3	40.4	225			0.456
6DC3A270E-FSD	460	3	41.6	218	20.8	131	0.457
6DC3A270E-TSE	575	3	32.5	172	16.3	103	1.538
6DC3A270E-TSK	208/230	3	80.7	450	40.4	263	0.114
6DC3A270E-TSK	460	3	40.4	225			0.456
6DC3A270L-FSD	460	3	41.6	218	20.8	131	0.457
6DC3A270L-TSE	575	3	32.5	172	16.3	103	1.538
6DC3A270L-TSK	208/230	3	80.7	450	40.4	263	0.114
6DC3A270L-TSK	460	3	40.4	225			0.456
6DC3F93K0-FSD	460	3	41.6	218	20.8	131	0.457

† ‡ See Section F Introduction for more information.

FE38

### Electrical Data - Copelametic Large Refrigerant-Cooled Compressors

Model †‡	Volts	PH	Across the Line		Part Winding Start		Winding Resistance Line to Line (Ohms) †
			Max RLA	LRA	Max RLA	LRA	
6DC3F93K0-TSE	575	3	32.5	172	16.3	103	1.538
6DC3F93K0-TSK	208/230	3	80.7	450	40.4	263	0.114
6DC3F93K0-TSK	460	3	40.4	225			0.456
6DC3F93KE-FSD	460	3	41.6	218	20.8	131	0.457
6DC3F93KE-TSE	575	3	32.5	172	16.3	103	1.538
6DC3F93KE-TSK	208/230	3	80.7	450	40.4	263	0.114
6DC3F93KE-TSK	460	3	40.4	225			0.456
6DC3F93KL-FSD	460	3	41.6	218	20.8	131	0.457
6DC3F93KL-TSE	575	3	32.5	172	16.3	103	1.538
6DC3F93KL-TSK	208/230	3	80.7	450	40.4	263	0.114
6DC3F93KL-TSK	460	3	40.4	225			0.456
6DD1A2700-FSD	460	3	42.9	218	21.5	131	0.457
6DD1A2700-TSK	208/230	3	89.3	450	44.7	263	0.114
6DD1A2700-TSK	460	3	44.6	225			0.456
6DD3A2700-ES8	200/220	3	82.5	445		141	0.336
6DD3A2700-ES8	380	3	47.9	260			0.112
6DD3A2700-FSD	460	3	41.6	218	20.8	131	0.457
6DD3A2700-TSE	575	3	32.5	172	16.3	103	1.538
6DD3A2700-TSK	208/230	3	80.7	450	40.4	263	0.114
6DD3A2700-TSK	460	3	40.4	225			0.456
6DD3A270E-FSD	460	3	41.6	218	20.8	131	0.457
6DD3A270E-TSE	575	3	32.5	172	16.3	103	1.538

† ‡ See Section F Introduction for more information.

FE39

### Electrical Data - Copelametic Large Refrigerant-Cooled Compressors

Model †‡	Volts	PH	Across the Line		Part Winding Start		Winding Resistance Line to Line (Ohms) †
			Max RLA	LRA	Max RLA	LRA	
6DD3A270E-TSK	208/230	3	80.7	450	40.4	263	0.114
6DD3A270E-TSK	460	3	40.4	225			0.456
6DD3A270L-FSD	460	3	41.6	218	20.8	131	0.457
6DD3A270L-TSE	575	3	32.5	172	16.3	103	1.538
6DD3A270L-TSK	208/230	3	80.7	450	40.4	263	0.114
6DD3A270L-TSK	460	3	40.4	225			0.456
6DD3F93K0-FSD	460	3	41.6	218	20.8	131	0.457
6DD3F93K0-TSE	575	3	32.5	172	16.3	103	1.538
6DD3F93K0-TSK	208/230	3	80.7	450	40.4	263	0.114
6DD3F93K0-TSK	460	3	40.4	225			0.456
6DD3F93KE-FSD	460	3	41.6	218	20.8	131	0.457
6DD3F93KE-TSE	575	3	32.5	172	16.3	103	1.538
6DD3F93KE-TSK	208/230	3	80.7	450	40.4	263	0.114
6DD3F93KE-TSK	460	3	40.4	225			0.456
6DD3F93KL-FSD	460	3	41.6	218	20.8	131	0.457
6DD3F93KL-TSE	575	3	32.5	172	16.3	103	1.538
6DD3F93KL-TSK	208/230	3	80.7	450	40.4	263	0.114
6DD3F93KL-TSK	460	3	40.4	225			0.456
6DE1A3000-ES8	200/220	3	95.9	500		164	0.294
6DE1A3000-ES8	380	3	55.6	289			0.098
6DE1A3000-TSK	208/230	3	110.9	470	55.5	292	0.111
6DE1A3000-TSK	460	3	55.5	235			0.444

† ‡ See Section F Introduction for more information.

FE40

### Electrical Data - Copelametic Large Refrigerant-Cooled Compressors

Model †‡	Volts	PH	Across the Line		Part Winding Start		Winding Resistance Line to Line (Ohms) †
			Max RLA	LRA	Max RLA	LRA	
6DE3A3000-FSD	460	3	42.9	235	21.4	141	0.45
6DE3A3000-TSE	575	3	39.6	200	19.8	130	1.46
6DE3A3000-TSK	208/230	3	95.6	470	47.8	292	0.111
6DE3A3000-TSK	460	3	47.8	235			0.444
6DE3A300E-FSD	460	3	42.9	235	21.4	141	0.45
6DE3A300E-TSE	575	3	39.6	200	19.8	130	1.46
6DE3A300E-TSK	208/230	3	95.6	470	47.8	292	0.111
6DE3A300E-TSK	460	3	47.8	235			0.444
6DE3A300L-FSD	460	3	42.9	235	21.4	141	0.45
6DE3A300L-TSE	575	3	39.6	200	19.8	130	1.46
6DE3A300L-TSK	208/230	3	95.6	470	47.8	292	0.111
6DE3A300L-TSK	460	3	47.8	235			0.444
6DE3F11M0-FSD	460	3	42.9	235	21.4	141	0.45
6DE3F11M0-TSE	575	3	39.6	200	19.8	130	1.46
6DE3F11M0-TSK	208/230	3	95.6	470	47.8	292	0.111
6DE3F11M0-TSK	460	3	47.8	235			0.444
6DE3F11ME-FSD	460	3	42.9	235	21.4	141	0.45
6DE3F11ME-TSE	575	3	39.6	200	19.8	130	1.46
6DE3F11ME-TSK	208/230	3	95.6	470	47.8	292	0.111
6DE3F11ME-TSK	460	3	47.8	235			0.444
6DE3F11ML-FSD	460	3	42.9	235	21.4	141	0.45
6DE3F11ML-TSE	575	3	39.6	200	19.8	130	1.46

† ‡ See Section F Introduction for more information.

FE41

### Electrical Data - Copelametic Large Refrigerant-Cooled Compressors

Model †‡	Volts	PH	Across the Line		Part Winding Start		Winding Resistance Line to Line (Ohms) †
			Max RLA	LRA	Max RLA	LRA	
6DE3F11ML-TSK	208/230	3	95.6	470	47.8	292	0.111
6DE3F11ML-TSK	460	3	47.8	235			0.444
6DF1A3000-ES8	200/220	3	95.9	500		164	0.294
6DF1A3000-ES8	380	3	55.6	289			0.098
6DF1A3000-FSD	460	3	53.6	235	26.8	141	0.45
6DF1A3000-TSK	208/230	3	110.9	470	55.5	292	0.111
6DF1A3000-TSK	460	3	55.5	235			0.444
6DF3A3000-FSD	460	3	42.9	235	21.4	141	0.45
6DF3A3000-TSE	575	3	39.6	200	19.8	130	1.46
6DF3A3000-TSK	208/230	3	95.6	470	47.8	292	0.111
6DF3A3000-TSK	460	3	47.8	235			0.444
6DF3A300E-FSD	460	3	42.9	235	21.4	141	0.45
6DF3A300E-TSE	575	3	39.6	200	19.8	130	1.46
6DF3A300E-TSK	208/230	3	95.6	470	47.8	292	0.111
6DF3A300E-TSK	460	3	47.8	235			0.444
6DF3A300L-FSD	460	3	42.9	235	21.4	141	0.45
6DF3A300L-TSE	575	3	39.6	200	19.8	130	1.46
6DF3A300L-TSK	208/230	3	95.6	470	47.8	292	0.111
6DF3A300L-TSK	460	3	47.8	235			0.444
6DF3F11M0-FSD	460	3	42.9	235	21.4	141	0.45
6DF3F11M0-TSE	575	3	39.6	200	19.8	130	1.46
6DF3F11M0-TSK	208/230	3	95.6	470	47.8	292	0.111

† ‡ See Section F Introduction for more information.

FE42

### Electrical Data - Copelametic Large Refrigerant-Cooled Compressors

Model †‡	Volts	PH	Across the Line		Part Winding Start		Winding Resistance Line to Line (Ohms) †
			Max RLA	LRA	Max RLA	LRA	
6DF3F11M0-TSK	460	3	47.8	235			0.444
6DF3F11ME-FSD	460	3	42.9	235	21.4	141	0.45
6DF3F11ME-TSE	575	3	39.6	200	19.8	130	1.46
6DF3F11ME-TSK	208/230	3	95.6	470	47.8	292	0.111
6DF3F11ME-TSK	460	3	47.8	235			0.444
6DF3F11ML-FSD	460	3	42.9	235	21.4	141	0.45
6DF3F11ML-TSE	575	3	39.6	200	19.8	130	1.46
6DF3F11ML-TSK	208/230	3	95.6	470	47.8	292	0.111
6DF3F11ML-TSK	460	3	47.8	235			0.444
6DG3A3500-ES8	200/220	3	NA	633		212	0.225
6DG3A3500-ES8	380	3	NA	365			0.075
6DG3A3500-FSD	460	3	66	315	33	195	0.32
6DG3A3500-FSU	200	3	135	650	67.5	400	0.069
6DG3A3500-FXD	460	3	NA	315		195	0.32
6DG3A3500-FXU	200	3	NA	650		400	0.069
6DG3A3500-TSE	575	3	46	245	23	152	1.016
6DG3A3500-TSN	230	3	125	594	62.5	340	0.085
6DG3A3500-TSN	460	3	62.5	297			0.34
6DG3A3500-TXE	575	3	NA	245		152	0.508
6DG3A3500-TXN	230	3	NA	594		340	0.085
6DG3A3500-TXN	460	3	NA	297			0.34
6DG3A3500E-FSD	460	3	66	315	33	195	0.32

† ‡ See Section F Introduction for more information.

FE43



### Electrical Data - Copelametic Large Refrigerant-Cooled Compressors

Model †‡	Volts	PH	Across the Line		Part Winding Start		Winding Resistance Line to Line (Ohms) †
			Max RLA	LRA	Max RLA	LRA	
6DG3A350E-FSU	200	3	135	650	67.5	400	0.069
6DG3A350E-TSE	575	3	46	245	23	152	1.016
6DG3A350E-TSN	230	3	168.6	594	62.5	340	0.085
6DG3A350E-TSN	460	3	84.3	297			0.34
6DG3A350L-FSD	460	3	66	315	33	195	0.32
6DG3A350L-FSU	200	3	135	650	67.5	400	0.069
6DG3A350L-TSE	575	3	46	245	23	152	1.016
6DG3A350L-TSN	230	3	168.6	594	62.5	340	0.085
6DG3A350L-TSN	460	3	84.3	297			0.34
6DG3R37M0-ES8	200/220	3	NA	633		212	0.225
6DG3R37M0-ES8	380	3	NA	365			0.075
6DG3R37M0-FSD	460	3	66	315	33	195	0.32
6DG3R37M0-FSU	200	3	135	650	67.5	400	0.069
6DG3R37M0-TSE	575	3	46	245	23	152	1.016
6DG3R37M0-TSN	230	3	125	594	62.5	340	0.085
6DG3R37M0-TSN	460	3	62.5	297			0.34
6DG3R37ME-FSD	460	3	66	315	33	195	0.32
6DG3R37ME-FSU	200	3	135	650	67.5	400	0.069
6DG3R37ME-TSE	575	3	46	245	23	152	1.016
6DG3R37ME-TSN	230	3	168.6	594	62.5	340	0.085
6DG3R37ME-TSN	460	3	84.3	297			0.34
6DG3R37ML-FSD	460	3	66	315	33	195	0.32

† ‡ See Section F Introduction for more information.

FE44

### Electrical Data - Copelametic Large Refrigerant-Cooled Compressors

Model †‡	Volts	PH	Across the Line		Part Winding Start		Winding Resistance Line to Line (Ohms) †
			Max RLA	LRA	Max RLA	LRA	
6DG3R37ML-FSU	200	3	135	650	67.5	400	0.069
6DG3R37ML-TSE	575	3	46	245	23	152	1.016
6DG3R37ML-TSN	230	3	168.6	594	62.5	340	0.085
6DG3R37ML-TSN	460	3	84.3	297			0.34
6DG8A3500-TSE	575	3	46	245	23	152	1.016
6DG8A3500-TSN	230	3	125	594	62.5	340	0.085
6DG8A3500-TSN	460	3	62.5	297			0.34
6DH1A2000-FSD	460	3	39.3	173	19.7	104	0.603
6DH1A2000-TSE	575	3	30	135	15	81	1.94
6DH1A2000-TSK	208/230	3	75	346	37.5	208	0.142
6DH1A2000-TSK	460	3	37.5	173			0.568
6DH1A3500-ES8	200/220	3	146.7	633		212	0.225
6DH1A3500-ES8	380	3	84.1	365			0.075
6DH1A3500-FSD	460	3	67.5	260	33.8	156	0.4
6DH1A3500-FXD	460	3	NA	260		156	0.4
6DH1A3500-TSE	575	3	50	230	25	138	1.076
6DH1A3500-TSK	208/230	3	125	565	62.5	340	0.088
6DH1A3500-TSK	460	3	62.5	283			0.352
6DH1A3500-TXE	575	3	NA	230		138	0.538
6DH1A3500-TXK	208/230	3	NA	565		340	0.088
6DH1A3500-TXK	460	3	NA	283			0.352
6DH1R35M0-ES8	200/220	3	146.7	633		212	0.225

† ‡ See Section F Introduction for more information.

FE45

### Electrical Data - Copelametic Large Refrigerant-Cooled Compressors

Model †‡	Volts	PH	Across the Line		Part Winding Start		Winding Resistance Line to Line (Ohms) †
			Max RLA	LRA	Max RLA	LRA	
6DH1R35M0-ES8	380	3	84.1	365			0.075
6DH1R35M0-FSD	460	3	67.5	260	33.8	156	0.4
6DH1R35M0-TSK	208/230	3	125	565	62.5	340	0.088
6DH1R35M0-TSK	460	3	62.5	283			0.352
6DH3A200E-TSE	575	3	30	135	15	81	1.94
6DH3A200E-TSK	208/230	3	75	346	37.5	208	0.142
6DH3A200E-TSK	460	3	37.5	173			0.568
6DH3A200L-TSE	575	3	30	135	15	81	1.94
6DH3A200L-TSK	208/230	3	75	346	37.5	208	0.142
6DH3A200L-TSK	460	3	37.5	173			0.568
6DH3A3500-FSD	460	3	62.6	260	31.3	156	0.39
6DH3A3500-TSE	575	3	42.5	230	21.3	138	1.16
6DH3A3500-TSK	208/230	3	125.1	565	62.6	340	0.087
6DH3A3500-TSK	460	3	62.6	283			0.348
6DH3A350E-FSD	460	3	62.6	260	31.3	156	0.39
6DH3A350E-TSE	575	3	42.5	230	21.3	138	1.16
6DH3A350E-TSK	208/230	3	147.1	565	62.6	340	0.087
6DH3A350E-TSK	460	3	73.6	283			0.348
6DH3A350L-FSD	460	3	62.6	260	31.3	156	0.39
6DH3A350L-TSE	575	3	42.5	230	21.3	138	1.16
6DH3A350L-TSK	208/230	3	147.1	565	62.6	340	0.087
6DH3A350L-TSK	460	3	73.6	283			0.348

† ‡ See Section F Introduction for more information.

FE46

### Electrical Data - Copelametic Large Refrigerant-Cooled Compressors

Model †‡	Volts	PH	Across the Line		Part Winding Start		Winding Resistance Line to Line (Ohms) †
			Max RLA	LRA	Max RLA	LRA	
6DH3R23ME-TSK	208/230	3	75	346	37.5	208	0.142
6DH3R23ME-TSK	460	3	37.5	173			0.568
6DH3R23ML-TSK	208/230	3	75	346	37.5	208	0.142
6DH3R23ML-TSK	460	3	37.5	173			0.568
6DH3R35M0-FSD	460	3	62.6	260	31.3	156	0.39
6DH3R35M0-TSE	575	3	42.5	230	21.3	138	1.16
6DH3R35M0-TSK	208/230	3	125.1	565	62.6	340	0.087
6DH3R35M0-TSK	460	3	62.6	283			0.348
6DH3R35ME-FSD	460	3	62.6	260	31.3	156	0.39
6DH3R35ME-TSE	575	3	42.5	230	21.3	138	1.16
6DH3R35ME-TSK	208/230	3	147.1	565	62.6	340	0.087
6DH3R35ME-TSK	460	3	73.6	283			0.348
6DH3R35ML-FSD	460	3	62.6	260	31.3	156	0.39
6DH3R35ML-TSE	575	3	42.5	230	21.3	138	1.16
6DH3R35ML-TSK	208/230	3	147.1	565	62.6	340	0.087
6DH3R35ML-TSK	460	3	73.6	283			0.348
6DJ1A4000-ES8	200/220	3	164.1	633		212	0.225
6DJ1A4000-ES8	380	3	96.9	365			0.075
6DJ1A4000-FSD	460	3	69.3	300	34.7	170	0.352
6DJ1A4000-FSU	200	3	170	660	85	400	0.067
6DJ1A4000-FXU	200	3	NA	660		400	0.067
6DJ1A4000-TSE	575	3	57.1	235	28.6	135	1.14

† ‡ See Section F Introduction for more information.

FE47

### Electrical Data - Copelametic Large Refrigerant-Cooled Compressors

Model †‡	Volts	PH	Across the Line		Part Winding Start		Winding Resistance Line to Line (Ohms) †
			Max RLA	LRA	Max RLA	LRA	
6DJ1A4000-TSN	230	3	141.4	594	70.5	340	0.085
6DJ1A4000-TSN	460	3	70.7	297			0.34
6DJ1A4000-TXE	575	3	NA	235		135	0.569
6DJ1A4000-TXN	230	3	NA	594		340	0.085
6DJ1A4000-TXN	460	3	NA	297			0.34
6DJ1R40M0-FSD	460	3	69.3	300	34.7	170	0.352
6DJ1R40M0-TSE	575	3	57.1	235	28.6	135	1.14
6DJ1R40M0-TSN	230	3	141.4	594	70.5	340	0.085
6DJ1R40M0-TSN	460	3	70.7	297			0.34
6DJ3A300E-TSE	575	3	40	200	20	130	1.46
6DJ3A300E-TSK	208/230	3	100	470	50	292	0.111
6DJ3A300E-TSK	460	3	50	235			0.444
6DJ3A300L-TSE	575	3	40	200	20	130	1.46
6DJ3A300L-TSK	208/230	3	100	470	50	292	0.111
6DJ3A300L-TSK	460	3	50	235			0.444
6DJ3A4000-FSD	460	3	70	315	35	195	0.32
6DJ3A4000-FSU	200	3	150	754	75	463	0.059
6DJ3A4000-FXD	460	3	NA	315		195	0.32
6DJ3A4000-FXU	200	3	NA	754		463	0.059
6DJ3A4000-TSE	575	3	53.5	245	26.75	152	1.016
6DJ3A4000-TSN	230	3	141.4	594	71	340	0.085
6DJ3A4000-TSN	460	3	70.7	297			0.34

† ‡ See Section F Introduction for more information.

FE48

### Electrical Data - Copelametic Large Refrigerant-Cooled Compressors

Model †‡	Volts	PH	Across the Line		Part Winding Start		Winding Resistance Line to Line (Ohms) †
			Max RLA	LRA	Max RLA	LRA	
6DJ3A4000-TXE	575	3	NA	245		152	0.508
6DJ3A4000-TXN	230	3	NA	594		340	0.085
6DJ3A4000-TXN	460	3	NA	297			0.34
6DJ3A400E-FSD	460	3	86.4	315	35	195	0.32
6DJ3A400E-FSU	200	3	150	754	75	463	0.059
6DJ3A400E-TSE	575	3	53.5	245	26.75	152	1.016
6DJ3A400E-TSN	230	3	141.4	594	71	340	0.085
6DJ3A400E-TSN	460	3	70.7	297			0.34
6DJ3A400L-FSD	460	3	86.4	315	35	195	0.32
6DJ3A400L-FSU	200	3	150	754	75	463	0.059
6DJ3A400L-TSE	575	3	53.5	245	26.75	152	1.016
6DJ3A400L-TSN	230	3	141.4	594	71	340	0.085
6DJ3A400L-TSN	460	3	70.7	297			0.34
6DJ3R28ME-TSE	575	3	40	200	20	130	1.46
6DJ3R28ME-TSK	208/230	3	100	470	50	292	0.111
6DJ3R28ME-TSK	460	3	50	235			0.444
6DJ3R28ML-TSE	575	3	40	200	20	130	1.46
6DJ3R28ML-TSK	208/230	3	100	470	50	292	0.111
6DJ3R28ML-TSK	460	3	50	235			0.444
6DJ3R40M0-FSD	460	3	70	315	35	195	0.32
6DJ3R40M0-FSU	200	3	150	754	75	463	0.059
6DJ3R40M0-TSE	575	3	53.5	245	26.75	152	1.016

† ‡ See Section F Introduction for more information.

FE49

### Electrical Data - Copelametic Large Refrigerant-Cooled Compressors

Model †‡	Volts	PH	Across the Line		Part Winding Start		Winding Resistance Line to Line (Ohms) †
			Max RLA	LRA	Max RLA	LRA	
6DJ3R40M0-TSN	230	3	141.4	594	71	340	0.085
6DJ3R40M0-TSN	460	3	70.7	297			0.34
6DJ3R40ME-FSD	460	3	86.4	315	35	195	0.32
6DJ3R40ME-FSU	200	3	150	754	75	463	0.059
6DJ3R40ME-TSE	575	3	53.5	245	26.75	152	1.016
6DJ3R40ME-TSN	230	3	141.4	594	71	340	0.085
6DJ3R40ME-TSN	460	3	70.7	297			0.34
6DJ3R40ML-FSD	460	3	86.4	315	35	195	0.32
6DJ3R40ML-FSU	200	3	150	754	75	463	0.059
6DJ3R40ML-TSE	575	3	53.5	245	26.75	152	1.016
6DJ3R40ML-TSN	230	3	141.4	594	71	340	0.085
6DJ3R40ML-TSN	460	3	70.7	297			0.34
6DJGA4000-FSU	200	3	150	754	75	463	0.059
6DK1A2000-TSK	208/230	3	75	346	37.5	208	0.142
6DK1A2000-TSK	460	3	37.5	173			0.568
6DK1A3500-ES8	200/220	3	146.7	633		212	0.225
6DK1A3500-ES8	380	3	84.1	365			0.075
6DK1A3500-FSD	460	3	67.5	260	33.8	156	0.4
6DK1A3500-TSE	575	3	50	230	25	138	1.076
6DK1A3500-TSK	208/230	3	125	565	62.5	340	0.088
6DK1A3500-TSK	460	3	62.5	283			0.352
6DK1A3500-TXE	575	3	NA	230		138	0.538

† ‡ See Section F Introduction for more information.

FE50

### Electrical Data - Copelametic Large Refrigerant-Cooled Compressors

Model †‡	Volts	PH	Across the Line		Part Winding Start		Winding Resistance Line to Line (Ohms) †
			Max RLA	LRA	Max RLA	LRA	
6DK1A3500-TXK	208/230	3	NA	565		340	0.088
6DK1A3500-TXK	460	3	NA	283			0.352
6DK1A350E-TSK	208/230	3	125	565	62.5	340	0.088
6DK1A350E-TSK	460	3	62.5	283			0.352
6DK1R35M0-ES8	200/220	3	146.7	633		212	0.225
6DK1R35M0-ES8	380	3	84.1	365			0.075
6DK1R35M0-FSD	460	3	67.5	260	33.8	156	0.4
6DK1R35M0-TSE	575	3	50	230	25	138	1.076
6DK1R35M0-TSK	208/230	3	125	565	62.5	340	0.088
6DK1R35M0-TSK	460	3	62.5	283			0.352
6DK3A200E-TSE	575	3	30	135	15	81	1.94
6DK3A200E-TSK	208/230	3	75	346	37.5	208	0.142
6DK3A200E-TSK	460	3	37.5	173			0.568
6DK3A200L-TSE	575	3	30	135	15	81	1.94
6DK3A200L-TSK	208/230	3	75	346	37.5	208	0.142
6DK3A200L-TSK	460	3	37.5	173			0.568
6DK3A3500-FSD	460	3	62.6	260	31.3	156	0.39
6DK3A3500-TSE	575	3	42.5	230	21.3	138	1.16
6DK3A3500-TSK	208/230	3	125.1	565	62.6	340	0.087
6DK3A3500-TSK	460	3	62.6	283			0.348
6DK3A350E-FSD	460	3	62.6	260	31.3	156	0.39
6DK3A350E-TSE	575	3	42.5	230	21.3	138	1.16

† ‡ See Section F Introduction for more information.

FE51



### Electrical Data - Copelametic Large Refrigerant-Cooled Compressors

Model †‡	Volts	PH	Across the Line		Part Winding Start		Winding Resistance Line to Line (Ohms) †
			Max RLA	LRA	Max RLA	LRA	
6DK3A350E-TSK	208/230	3	147.1	565	62.6	340	0.087
6DK3A350E-TSK	460	3	73.6	283			0.348
6DK3A350L-FSD	460	3	62.6	260	31.3	156	0.39
6DK3A350L-TSE	575	3	42.5	230	21.3	138	1.16
6DK3A350L-TSK	208/230	3	147.1	565	62.6	340	0.087
6DK3A350L-TSK	460	3	73.6	283			0.348
6DK3R23ME-TSK	208/230	3	75	346	37.5	208	0.142
6DK3R23ME-TSK	460	3	37.5	173			0.568
6DK3R35M0-FSD	460	3	62.6	260	31.3	156	0.39
6DK3R35M0-TSE	575	3	42.5	230	21.3	138	1.16
6DK3R35M0-TSK	208/230	3	125.1	565	62.6	340	0.087
6DK3R35M0-TSK	460	3	62.6	283			0.348
6DK3R35ME-FSD	460	3	62.6	260	31.3	156	0.39
6DK3R35ME-TSE	575	3	42.5	230	21.3	138	1.16
6DK3R35ME-TSK	208/230	3	147.1	565	62.6	340	0.087
6DK3R35ME-TSK	460	3	73.6	283			0.348
6DK3R35ML-FSD	460	3	62.6	260	31.3	156	0.39
6DK3R35ML-TSE	575	3	42.5	230	21.3	138	1.16
6DK3R35ML-TSK	208/230	3	147.1	565	62.6	340	0.087
6DK3R35ML-TSK	460	3	73.6	283			0.348
6DK8A3500-TSK	208/230	3	125.1	565	62.6	340	0.087
6DK8A3500-TSK	460	3	62.6	283			0.348

† ‡ See Section F Introduction for more information.

FE52

### Electrical Data - Copelametic Large Refrigerant-Cooled Compressors

Model †‡	Volts	PH	Across the Line		Part Winding Start		Winding Resistance Line to Line (Ohms) †
			Max RLA	LRA	Max RLA	LRA	
6DL1A2700-FSD	460	3	42.9	218	21.5	131	0.457
6DL1A2700-TSE	575	3	35	172	17.5	103	1.538
6DL1A2700-TSK	208/230	3	89.3	450	44.7	263	0.114
6DL1A2700-TSK	460	3	44.6	225			0.456
6DL3A2700-ES8	200/220	3	82.5	445		141	0.336
6DL3A2700-ES8	380	3	47.9	260			0.112
6DL3A2700-FSD	460	3	41.6	218	20.8	131	0.457
6DL3A2700-TSE	575	3	32.5	172	16.3	103	1.538
6DL3A2700-TSK	208/230	3	80.7	450	40.4	263	0.114
6DL3A2700-TSK	460	3	40.4	225			0.456
6DL3A270E-FSD	460	3	41.6	218	20.8	131	0.457
6DL3A270E-TSE	575	3	32.5	172	16.3	103	1.538
6DL3A270E-TSK	208/230	3	80.7	450	40.4	263	0.114
6DL3A270E-TSK	460	3	40.4	225			0.456
6DL3A270L-FSD	460	3	41.6	218	20.8	131	0.457
6DL3A270L-TSE	575	3	32.5	172	16.3	103	1.538
6DL3A270L-TSK	208/230	3	80.7	450	40.4	263	0.114
6DL3A270L-TSK	460	3	40.4	225			0.456
6DL3F93K0-ES8	200/220	3	82.5	445		141	0.336
6DL3F93K0-ES8	380	3	47.9	260			0.112
6DL3F93K0-FSD	460	3	41.6	218	20.8	131	0.457
6DL3F93K0-TSE	575	3	32.5	172	16.3	103	1.538

† ‡ See Section F Introduction for more information.

FE53

### Electrical Data - Copelametic Large Refrigerant-Cooled Compressors

Model †‡	Volts	PH	Across the Line		Part Winding Start		Winding Resistance Line to Line (Ohms) †
			Max RLA	LRA	Max RLA	LRA	
6DL3F93K0-TSK	208/230	3	80.7	450	40.4	263	0.114
6DL3F93K0-TSK	460	3	40.4	225			0.456
6DL3F93KE-FSD	460	3	41.6	218	20.8	131	0.457
6DL3F93KE-TSE	575	3	32.5	172	16.3	103	1.538
6DL3F93KE-TSK	208/230	3	80.7	450	40.4	263	0.114
6DL3F93KE-TSK	460	3	40.4	225			0.456
6DL3F93KL-FSD	460	3	41.6	218	20.8	131	0.457
6DL3F93KL-TSE	575	3	32.5	172	16.3	103	1.538
6DL3F93KL-TSK	208/230	3	80.7	450	40.4	263	0.114
6DL3F93KL-TSK	460	3	40.4	225			0.456
6DL8A2700-TSK	208/230	3	80.7	450	40.4	263	0.114
6DL8A2700-TSK	460	3	40.4	225			0.456
6DM3A3500-ES8	200/220	3	NA	633		212	0.225
6DM3A3500-ES8	380	3	NA	365			0.075
6DM3A3500-FSD	460	3	66	315	33	195	0.32
6DM3A3500-FSU	200	3	135	650	67.5	400	0.069
6DM3A3500-FXD	460	3	NA	315		195	0.32
6DM3A3500-FXU	200	3	NA	650		400	0.069
6DM3A3500-TSE	575	3	46	245	23	152	1.016
6DM3A3500-TSN	230	3	125	594	62.5	340	0.085
6DM3A3500-TSN	460	3	62.5	297			0.34
6DM3A3500-TXE	575	3	NA	245		152	0.508

† ‡ See Section F Introduction for more information.

FE54

### Electrical Data - Copelametic Large Refrigerant-Cooled Compressors

Model †‡	Volts	PH	Across the Line		Part Winding Start		Winding Resistance Line to Line (Ohms) †
			Max RLA	LRA	Max RLA	LRA	
6DM3A3500-TXN	230	3	NA	594		340	0.085
6DM3A3500-TXN	460	3	NA	297			0.34
6DM3A350E-ES8	200/220	3	NA	633		212	0.225
6DM3A350E-ES8	380	3	NA	365			0.075
6DM3A350E-FSD	460	3	66	315	33	195	0.32
6DM3A350E-FSU	200	3	135	650	67.5	400	0.069
6DM3A350E-TSE	575	3	46	245	23	152	1.016
6DM3A350E-TSN	230	3	168.6	594	62.5	340	0.085
6DM3A350E-TSN	460	3	84.3	297			0.34
6DM3A350L-FSD	460	3	66	315	33	195	0.32
6DM3A350L-FSU	200	3	135	650	67.5	400	0.069
6DM3A350L-TSE	575	3	46	245	23	152	1.016
6DM3A350L-TSN	230	3	168.6	594	62.5	340	0.085
6DM3A350L-TSN	460	3	84.3	297			0.34
6DM3R37M0-FSD	460	3	66	315	33	195	0.32
6DM3R37M0-FSU	200	3	135	650	67.5	400	0.069
6DM3R37M0-TSE	575	3	46	245	23	152	1.016
6DM3R37M0-TSN	230	3	125	594	62.5	340	0.085
6DM3R37M0-TSN	460	3	62.5	297			0.34
6DM3R37ME-FSD	460	3	66	315	33	195	0.32
6DM3R37ME-FSU	200	3	135	650	67.5	400	0.069
6DM3R37ME-TSE	575	3	46	245	23	152	1.016

† ‡ See Section F Introduction for more information.

FE55

### Electrical Data - Copelametic Large Refrigerant-Cooled Compressors

Model †‡	Volts	PH	Across the Line		Part Winding Start		Winding Resistance Line to Line (Ohms) †
			Max RLA	LRA	Max RLA	LRA	
6DM3R37ME-TSN	230	3	168.6	594	62.5	340	0.085
6DM3R37ME-TSN	460	3	84.3	297			0.34
6DM3R37ML-FSD	460	3	66	315	33	195	0.32
6DM3R37ML-FSU	200	3	135	650	67.5	400	0.069
6DM3R37ML-TSE	575	3	46	245	23	152	1.016
6DM3R37ML-TSN	230	3	168.6	594	62.5	340	0.085
6DM3R37ML-TSN	460	3	84.3	297			0.34
6DN3A3500-ES8	200/220	3	NA	633		212	0.225
6DN3A3500-ES8	380	3	NA	365			0.075
6DN3A3500-FSD	460	3	66	315	33	195	0.32
6DN3A3500-FSU	200	3	135	650	67.5	400	0.069
6DN3A3500-FXD	460	3	NA	315		195	0.32
6DN3A3500-FXU	200	3	NA	650		400	0.069
6DN3A3500-TSE	575	3	46	245	23	152	1.016
6DN3A3500-TSN	230	3	125	594	62.5	340	0.085
6DN3A3500-TSN	460	3	62.5	297			0.34
6DN3A3500-TXE	575	3	NA	245		152	0.508
6DN3A3500-TXN	230	3	NA	594		340	0.085
6DN3A3500-TXN	460	3	NA	297			0.34
6DN3A350E-ES8	200/220	3	NA	633		212	0.225
6DN3A350E-ES8	380	3	NA	365			0.075
6DN3A350E-FSD	460	3	66	315	33	195	0.32

† ‡ See Section F Introduction for more information.

FE56

### Electrical Data - Copelametic Large Refrigerant-Cooled Compressors

Model †‡	Volts	PH	Across the Line		Part Winding Start		Winding Resistance Line to Line (Ohms) †
			Max RLA	LRA	Max RLA	LRA	
6DN3A350E-FSU	200	3	135	650	67.5	400	0.069
6DN3A350E-TSE	575	3	46	245	23	152	1.016
6DN3A350E-TSN	230	3	168.6	594	62.5	340	0.085
6DN3A350E-TSN	460	3	84.3	297			0.34
6DN3A350L-FSD	460	3	66	315	33	195	0.32
6DN3A350L-FSU	200	3	135	650	67.5	400	0.069
6DN3A350L-TSE	575	3	46	245	23	152	1.016
6DN3A350L-TSN	230	3	168.6	594	62.5	340	0.085
6DN3A350L-TSN	460	3	84.3	297			0.34
6DN3R37M0-FSD	460	3	66	315	33	195	0.32
6DN3R37M0-FSU	200	3	135	650	67.5	400	0.069
6DN3R37M0-TSE	575	3	46	245	23	152	1.016
6DN3R37M0-TSN	230	3	125	594	62.5	340	0.085
6DN3R37M0-TSN	460	3	62.5	297			0.34
6DN3R37ME-FSD	460	3	66	315	33	195	0.32
6DN3R37ME-FSU	200	3	135	650	67.5	400	0.069
6DN3R37ME-TSE	575	3	46	245	23	152	1.016
6DN3R37ME-TSN	230	3	168.6	594	62.5	340	0.085
6DN3R37ME-TSN	460	3	84.3	297			0.34
6DN3R37ML-FSD	460	3	66	315	33	195	0.32
6DN3R37ML-FSU	200	3	135	650	67.5	400	0.069
6DN3R37ML-TSE	575	3	46	245	23	152	1.016

† ‡ † See Section F Introduction for more information.

FE57

### Electrical Data - Copelametic Large Refrigerant-Cooled Compressors

Model †‡	Volts	PH	Across the Line		Part Winding Start		Winding Resistance Line to Line (Ohms) †
			Max RLA	LRA	Max RLA	LRA	
6DN3R37ML-TSN	230	3	168.6	594	62.5	340	0.085
6DN3R37ML-TSN	460	3	84.3	297			0.34
6DP1A2000-TSK	208/230	3	75	346	37.5	208	0.142
6DP1A2000-TSK	460	3	37.5	173			0.568
6DP1A3500-ES8	200/220	3	146.7	633		212	0.225
6DP1A3500-ES8	380	3	84.1	365			0.075
6DP1A3500-FSD	460	3	67.5	260	33.8	156	0.4
6DP1A3500-FXD	460	3	NA	260		156	0.4
6DP1A3500-TSE	575	3	50	230	25	138	1.076
6DP1A3500-TSK	208/230	3	125	565	62.5	340	0.088
6DP1A3500-TSK	460	3	62.5	283			0.352
6DP1A3500-TXE	575	3	NA	230		138	0.538
6DP1A3500-TXK	208/230	3	NA	565		340	0.088
6DP1A3500-TXK	460	3	NA	283			0.352
6DP1A3500E-TSK	208/230	3	125	565	62.5	340	0.088
6DP1A3500E-TSK	460	3	62.5	283			0.352
6DP1R35M0-ES8	200/220	3	146.7	633		212	0.225
6DP1R35M0-ES8	380	3	84.1	365			0.075
6DP1R35M0-FSD	460	3	67.5	260	33.8	156	0.4
6DP1R35M0-TSE	575	3	50	230	25	138	1.076
6DP1R35M0-TSK	208/230	3	125	565	62.5	340	0.088
6DP1R35M0-TSK	460	3	62.5	283			0.352

† ‡ See Section F Introduction for more information.

FE58

### Electrical Data - Copelametic Large Refrigerant-Cooled Compressors

Model † ¥	Volts	PH	Across the Line		Part Winding Start		Winding Resistance Line to Line (Ohms) †
			Max RLA	LRA	Max RLA	LRA	
6DP3A200E-TSE	575	3	30	135	15	81	1.94
6DP3A200E-TSK	208/230	3	75	346	37.5	208	0.142
6DP3A200E-TSK	460	3	37.5	173			0.568
6DP3A200E-TXK	208/230	3	NA	346		208	0.142
6DP3A200E-TXK	460	3	NA	173			0.568
6DP3A200L-TSE	575	3	30	135	15	81	1.94
6DP3A200L-TSK	208/230	3	75	346	37.5	208	0.142
6DP3A200L-TSK	460	3	37.5	173			0.568
6DP3A3500-FSD	460	3	62.6	260	31.3	156	0.39
6DP3A3500-TSE	575	3	42.5	230	21.3	138	1.16
6DP3A3500-TSK	208/230	3	125.1	565	62.6	340	0.087
6DP3A3500-TSK	460	3	62.6	283			0.348
6DP3A350E-FSD	460	3	62.6	260	31.3	156	0.39
6DP3A350E-TSE	575	3	42.5	230	21.3	138	1.16
6DP3A350E-TSK	208/230	3	147.1	565	62.6	340	0.087
6DP3A350E-TSK	460	3	73.6	283			0.348
6DP3A350L-FSD	460	3	62.6	260	31.3	156	0.39
6DP3A350L-TSE	575	3	42.5	230	21.3	138	1.16
6DP3A350L-TSK	208/230	3	147.1	565	62.6	340	0.087
6DP3A350L-TSK	460	3	73.6	283			0.348
6DP3R23ME-TSK	208/230	3	75	346	37.5	208	0.142
6DP3R23ME-TSK	460	3	37.5	173			0.568

† † ¥ See Section F Introduction for more information.

FE59



### Electrical Data - Copelametic Large Refrigerant-Cooled Compressors

Model †‡	Volts	PH	Across the Line		Part Winding Start		Winding Resistance Line to Line (Ohms) †
			Max RLA	LRA	Max RLA	LRA	
6DP3R23ME-TXK	208/230	3	NA	346		208	0.142
6DP3R23ME-TXK	460	3	NA	173			0.568
6DP3R35M0-FSD	460	3	62.6	260	31.3	156	0.39
6DP3R35M0-TSE	575	3	42.5	230	21.3	138	1.16
6DP3R35M0-TSK	208/230	3	125.1	565	62.6	340	0.087
6DP3R35M0-TSK	460	3	62.6	283			0.348
6DP3R35ME-FSD	460	3	62.6	260	31.3	156	0.39
6DP3R35ME-TSE	575	3	42.5	230	21.3	138	1.16
6DP3R35ME-TSK	208/230	3	147.1	565	62.6	340	0.087
6DP3R35ME-TSK	460	3	73.6	283			0.348
6DP3R35ML-FSD	460	3	62.6	260	31.3	156	0.39
6DP3R35ML-TSE	575	3	42.5	230	21.3	138	1.16
6DP3R35ML-TSK	208/230	3	147.1	565	62.6	340	0.087
6DP3R35ML-TSK	460	3	73.6	283			0.348
6DP5A3500-FSD	460	3	67.5	260	33.8	156	0.4
6DP5A3500-TSE	575	3	50	230	25	138	1.076
6DR1A4000-ES8	200/220	3	164.1	633		212	0.225
6DR1A4000-ES8	380	3	96.9	365			0.075
6DR1A4000-FSD	460	3	69.3	300	34.7	170	0.352
6DR1A4000-FSU	200	3	170	660	85	400	0.067
6DR1A4000-FXU	200	3	NA	660		400	0.067
6DR1A4000-TSE	575	3	57.1	235	28.6	135	1.14

† ‡ See Section F Introduction for more information.

FE60

### Electrical Data - Copelametic Large Refrigerant-Cooled Compressors

Model †‡	Volts	PH	Across the Line		Part Winding Start		Winding Resistance Line to Line (Ohms) †
			Max RLA	LRA	Max RLA	LRA	
6DR1A4000-TSN	230	3	141.4	594	70.5	340	0.085
6DR1A4000-TSN	460	3	70.7	297			0.34
6DR1A4000-TXE	575	3	NA	235		135	0.569
6DR1A4000-TXN	230	3	NA	594		340	0.085
6DR1A4000-TXN	460	3	NA	297			0.34
6DR1A400E-ES8	200/220	3	164.1	633		212	0.225
6DR1A400E-ES8	380	3	96.9	365			0.075
6DR1R40M0-ES8	200/220	3	164.1	633		212	0.225
6DR1R40M0-ES8	380	3	96.9	365			0.075
6DR1R40M0-FSD	460	3	69.3	300	34.7	170	0.352
6DR1R40M0-TSN	230	3	141.4	594	70.5	340	0.085
6DR1R40M0-TSN	460	3	70.7	297			0.34
6DR3A300E-TSE	575	3	40	200	20	130	1.46
6DR3A300E-TSK	208/230	3	100	470	50	292	0.111
6DR3A300E-TSK	460	3	50	235			0.444
6DR3A300L-TSE	575	3	40	200	20	130	1.46
6DR3A300L-TSK	208/230	3	100	470	50	292	0.111
6DR3A300L-TSK	460	3	50	235			0.444
6DR3A4000-FSD	460	3	70	315	35	195	0.32
6DR3A4000-FSU	200	3	150	754	75	463	0.059
6DR3A4000-FXD	460	3	NA	315		195	0.32
6DR3A4000-FXU	200	3	NA	754		463	0.059

† ‡ See Section F Introduction for more information.

FE61

### Electrical Data - Copelametic Large Refrigerant-Cooled Compressors

Model †‡	Volts	PH	Across the Line		Part Winding Start		Winding Resistance Line to Line (Ohms) †
			Max RLA	LRA	Max RLA	LRA	
6DR3A4000-TSE	575	3	53.5	245	26.75	152	1.016
6DR3A4000-TSN	230	3	141.4	594	71	340	0.085
6DR3A4000-TSN	460	3	70.7	297			0.34
6DR3A4000-TXE	575	3	NA	245		152	0.508
6DR3A4000-TXN	230	3	NA	594		340	0.085
6DR3A4000-TXN	460	3	NA	297			0.34
6DR3A400E-FSD	460	3	86.4	315	35	195	0.32
6DR3A400E-FSU	200	3	150	754	75	463	0.059
6DR3A400E-TSE	575	3	53.5	245	26.75	152	1.016
6DR3A400E-TSN	230	3	141.4	594	71	340	0.085
6DR3A400E-TSN	460	3	70.7	297			0.34
6DR3A400L-FSD	460	3	86.4	315	35	195	0.32
6DR3A400L-FSU	200	3	150	754	75	463	0.059
6DR3A400L-TSE	575	3	53.5	245	26.75	152	1.016
6DR3A400L-TSN	230	3	141.4	594	71	340	0.085
6DR3A400L-TSN	460	3	70.7	297			0.34
6DR3R28ME-TSK	208/230	3	100	470	50	292	0.111
6DR3R28ME-TSK	460	3	50	235			0.444
6DR3R28ML-TSK	208/230	3	100	470	50	292	0.111
6DR3R28ML-TSK	460	3	50	235			0.444
6DR3R40M0-FSD	460	3	70	315	35	195	0.32
6DR3R40M0-FSU	200	3	150	754	75	463	0.059

† ‡ See Section F Introduction for more information.

FE62

### Electrical Data - Copelametic Large Refrigerant-Cooled Compressors

Model †‡	Volts	PH	Across the Line		Part Winding Start		Winding Resistance Line to Line (Ohms) †
			Max RLA	LRA	Max RLA	LRA	
6DR3R40M0-TSE	575	3	53.5	245	26.75	152	1.016
6DR3R40M0-TSN	230	3	141.4	594	71	340	0.085
6DR3R40M0-TSN	460	3	70.7	297			0.34
6DR3R40ME-FSD	460	3	86.4	315	35	195	0.32
6DR3R40ME-FSU	200	3	150	754	75	463	0.059
6DR3R40ME-TSE	575	3	53.5	245	26.75	152	1.016
6DR3R40ME-TSN	230	3	141.4	594	71	340	0.085
6DR3R40ME-TSN	460	3	70.7	297			0.34
6DR3R40ML-FSD	460	3	86.4	315	35	195	0.32
6DR3R40ML-FSU	200	3	150	754	75	463	0.059
6DR3R40ML-TSE	575	3	53.5	245	26.75	152	1.016
6DR3R40ML-TSN	230	3	141.4	594	71	340	0.085
6DR3R40ML-TSN	460	3	70.7	297			0.34
6DRGA4000-FSU	200	3	150	754	75	463	0.059
6DS1A4000-ES8	200/220	3	164.1	633		212	0.225
6DS1A4000-ES8	380	3	96.9	365			0.075
6DS1A4000-FSD	460	3	69.3	300	34.7	170	0.352
6DS1A4000-FSU	200	3	170	660	85	400	0.067
6DS1A4000-FXU	200	3	NA	660		400	0.067
6DS1A4000-TSE	575	3	57.1	235	28.6	135	1.14
6DS1A4000-TSN	230	3	141.4	594	70.5	340	0.085
6DS1A4000-TSN	460	3	70.7	297			0.34

† ‡ See Section F Introduction for more information.

FE63

### Electrical Data - Copelametic Large Refrigerant-Cooled Compressors

Model †‡	Volts	PH	Across the Line		Part Winding Start		Winding Resistance Line to Line (Ohms) †
			Max RLA	LRA	Max RLA	LRA	
6DS1A4000-TXE	575	3	NA	235		135	0.569
6DS1A4000-TXN	230	3	NA	594		340	0.085
6DS1A4000-TXN	460	3	NA	297			0.34
6DS1R40M0-ES8	200/220	3	164.1	633		212	0.225
6DS1R40M0-ES8	380	3	96.9	365			0.075
6DS1R40M0-FSD	460	3	69.3	300	34.7	170	0.352
6DS1R40M0-FSU	200	3	170	660	85	400	0.067
6DS1R40M0-TSE	575	3	57.1	235	28.6	135	1.14
6DS1R40M0-TSN	230	3	141.4	594	70.5	340	0.085
6DS1R40M0-TSN	460	3	70.7	297			0.34
6DS3A300E-TSE	575	3	40	200	20	130	1.46
6DS3A300E-TSK	208/230	3	100	470	50	292	0.111
6DS3A300E-TSK	460	3	50	235			0.444
6DS3A300L-TSE	575	3	40	200	20	130	1.46
6DS3A300L-TSK	208/230	3	100	470	50	292	0.111
6DS3A300L-TSK	460	3	50	235			0.444
6DS3A4000-FSD	460	3	70	315	35	195	0.32
6DS3A4000-FSU	200	3	150	754	75	463	0.059
6DS3A4000-FXD	460	3	NA	315		195	0.32
6DS3A4000-FXU	200	3	NA	754		463	0.059
6DS3A4000-TSE	575	3	53.5	245	26.75	152	1.016
6DS3A4000-TSN	230	3	141.4	594	71	340	0.085

† ‡ See Section F Introduction for more information.

FE64

### Electrical Data - Copelametic Large Refrigerant-Cooled Compressors

Model †‡	Volts	PH	Across the Line		Part Winding Start		Winding Resistance Line to Line (Ohms) †
			Max RLA	LRA	Max RLA	LRA	
6DS3A4000-TSN	460	3	70.7	297			0.34
6DS3A4000-TXE	575	3	NA	245		152	0.508
6DS3A4000-TXN	230	3	NA	594		340	0.085
6DS3A4000-TXN	460	3	NA	297			0.34
6DS3A400E-FSD	460	3	86.4	315	35	195	0.32
6DS3A400E-FSU	200	3	150	754	75	463	0.059
6DS3A400E-TSE	575	3	53.5	245	26.75	152	1.016
6DS3A400E-TSN	230	3	141.4	594	71	340	0.085
6DS3A400E-TSN	460	3	70.7	297			0.34
6DS3A400L-FSD	460	3	86.4	315	35	195	0.32
6DS3A400L-FSU	200	3	150	754	75	463	0.059
6DS3A400L-TSE	575	3	53.5	245	26.75	152	1.016
6DS3A400L-TSN	230	3	141.4	594	71	340	0.085
6DS3A400L-TSN	460	3	70.7	297			0.34
6DS3R28ME-TSE	575	3	40	200	20	130	1.46
6DS3R28ME-TSK	208/230	3	100	470	50	292	0.111
6DS3R28ME-TSK	460	3	50	235			0.444
6DS3R28ML-TSE	575	3	40	200	20	130	1.46
6DS3R28ML-TSK	208/230	3	100	470	50	292	0.111
6DS3R28ML-TSK	460	3	50	235			0.444
6DS3R40M0-FSD	460	3	70	315	35	195	0.32
6DS3R40M0-FSU	200	3	150	754	75	463	0.059

† ‡ See Section F Introduction for more information.

FE65

### Electrical Data - Copelametic Large Refrigerant-Cooled Compressors

Model †‡	Volts	PH	Across the Line		Part Winding Start		Winding Resistance Line to Line (Ohms) †
			Max RLA	LRA	Max RLA	LRA	
6DS3R40M0-TSE	575	3	53.5	245	26.75	152	1.016
6DS3R40M0-TSN	230	3	141.4	594	71	340	0.085
6DS3R40M0-TSN	460	3	70.7	297			0.34
6DS3R40ME-FSD	460	3	86.4	315	35	195	0.32
6DS3R40ME-FSU	200	3	150	754	75	463	0.059
6DS3R40ME-TSE	575	3	53.5	245	26.75	152	1.016
6DS3R40ME-TSN	230	3	141.4	594	71	340	0.085
6DS3R40ME-TSN	460	3	70.7	297			0.34
6DS3R40ML-FSD	460	3	86.4	315	35	195	0.32
6DS3R40ML-FSU	200	3	150	754	75	463	0.059
6DS3R40ML-TSE	575	3	53.5	245	26.75	152	1.016
6DS3R40ML-TSN	230	3	141.4	594	71	340	0.085
6DS3R40ML-TSN	460	3	70.7	297			0.34
6DSGA4000-FSU	200	3	150	754	75	463	0.059
6DT1A3000-ES8	200/220	3	95.9	500		164	0.294
6DT1A3000-ES8	380	3	55.6	289			0.098
6DT1A3000-FSD	460	3	53.6	235	26.8	141	0.45
6DT1A3000-TSE	575	3	40	200	20	130	1.46
6DT1A3000-TSK	208/230	3	110.9	470	55.5	292	0.111
6DT1A3000-TSK	460	3	55.5	235			0.444
6DT1F11M0-ES8	200/220	3	95.9	500		164	0.294
6DT1F11M0-ES8	380	3	55.6	289			0.098

† ‡ See Section F Introduction for more information.

FE66

### Electrical Data - Copelametic Large Refrigerant-Cooled Compressors

Model †‡	Volts	PH	Across the Line		Part Winding Start		Winding Resistance Line to Line (Ohms) †
			Max RLA	LRA	Max RLA	LRA	
6DT1F11M0-FSD	460	3	53.6	235	26.8	141	0.45
6DT3A3000-FSD	460	3	42.9	235	21.4	141	0.45
6DT3A3000-TSE	575	3	39.6	200	19.8	130	1.46
6DT3A3000-TSK	208/230	3	95.6	470	47.8	292	0.111
6DT3A3000-TSK	460	3	47.8	235			0.444
6DT3A300E-FSD	460	3	42.9	235	21.4	141	0.45
6DT3A300E-TSE	575	3	39.6	200	19.8	130	1.46
6DT3A300E-TSK	208/230	3	95.6	470	47.8	292	0.111
6DT3A300E-TSK	460	3	47.8	235			0.444
6DT3A300L-FSD	460	3	42.9	235	21.4	141	0.45
6DT3A300L-TSE	575	3	39.6	200	19.8	130	1.46
6DT3A300L-TSK	208/230	3	95.6	470	47.8	292	0.111
6DT3A300L-TSK	460	3	47.8	235			0.444
6DT3A3010-ESX	200/220	3	94.6	500			0.294
6DT3A3010-ESX	380	3	68.8	289			0.098
6DT3A301E-ESX	200/220	3	94.6	500			0.294
6DT3A301E-ESX	380	3	81.7	289			0.098
6DT3A301L-ESX	200/220	3	94.6	500			0.294
6DT3A301L-ESX	380	3	81.7	289			0.098
6DT3F11M0-FSD	460	3	42.9	235	21.4	141	0.45
6DT3F11M0-TSE	575	3	39.6	200	19.8	130	1.46
6DT3F11M0-TSK	208/230	3	95.6	470	47.8	292	0.111

† ‡ See Section F Introduction for more information.

FE67



### Electrical Data - Copelametic Large Refrigerant-Cooled Compressors

Model †‡	Volts	PH	Across the Line		Part Winding Start		Winding Resistance Line to Line (Ohms) †
			Max RLA	LRA	Max RLA	LRA	
6DT3F11M0-TSK	460	3	47.8	235			0.444
6DT3F11ME-FSD	460	3	42.9	235	21.4	141	0.45
6DT3F11ME-TSE	575	3	39.6	200	19.8	130	1.46
6DT3F11ME-TSK	208/230	3	95.6	470	47.8	292	0.111
6DT3F11ME-TSK	460	3	47.8	235			0.444
6DT3F11ML-FSD	460	3	42.9	235	21.4	141	0.45
6DT3F11ML-TSE	575	3	39.6	200	19.8	130	1.46
6DT3F11ML-TSK	208/230	3	95.6	470	47.8	292	0.111
6DT3F11ML-TSK	460	3	47.8	235			0.444
6DW3A3000-FSD	460	3	50	260	25	156	0.39
6DW3A3000-TSE	575	3	40	230	20	138	1.16
6DW3A3000-TSK	208/230	3	105	565	52.5	340	0.087
6DW3A3000-TSK	460	3	52.5	283			0.348
6DW3A300E-FSD	460	3	50	260	25	156	0.39
6DW3A300E-TSE	575	3	40	230	20	138	1.16
6DW3A300E-TSK	208/230	3	134.3	565	52.5	340	0.087
6DW3A300E-TSK	460	3	67.1	283			0.348
6DW3A300L-FSD	460	3	50	260	25	156	0.39
6DW3A300L-TSE	575	3	40	230	20	138	1.16
6DW3A300L-TSK	208/230	3	134.3	565	52.5	340	0.087
6DW3A300L-TSK	460	3	67.1	283			0.348
6DW3R32M0-FSD	460	3	50	260	25	156	0.39

† ‡ See Section F Introduction for more information.

FE68

### Electrical Data - Copelametic Large Refrigerant-Cooled Compressors

Model †‡	Volts	PH	Across the Line		Part Winding Start		Winding Resistance Line to Line (Ohms) †
			Max RLA	LRA	Max RLA	LRA	
6DW3R32M0-TSE	575	3	40	230	20	138	1.16
6DW3R32M0-TSK	208/230	3	105	565	52.5	340	0.087
6DW3R32M0-TSK	460	3	52.5	283			0.348
6DW3R32ME-FSD	460	3	50	260	25	156	0.39
6DW3R32ME-TSE	575	3	40	230	20	138	1.16
6DW3R32ME-TSK	208/230	3	134.3	565	52.5	340	0.087
6DW3R32ME-TSK	460	3	67.1	283			0.348
6DW3R32ML-FSD	460	3	50	260	25	156	0.39
6DW3R32ML-TSE	575	3	40	230	20	138	1.16
6DW3R32ML-TSK	208/230	3	134.3	565	52.5	340	0.087
6DW3R32ML-TSK	460	3	67.1	283			0.348
6DY3A3000-FSD	460	3	50	260	25	156	0.39
6DY3A3000-TSE	575	3	40	230	20	138	1.16
6DY3A3000-TSK	208/230	3	105	565	52.5	340	0.087
6DY3A3000-TSK	460	3	52.5	283			0.348
6DY3A300E-FSD	460	3	50	260	25	156	0.39
6DY3A300E-TSE	575	3	40	230	20	138	1.16
6DY3A300E-TSK	208/230	3	134.3	565	52.5	340	0.087
6DY3A300E-TSK	460	3	67.1	283			0.348
6DY3A300L-FSD	460	3	50	260	25	156	0.39
6DY3A300L-TSE	575	3	40	230	20	138	1.16
6DY3A300L-TSK	208/230	3	134.3	565	52.5	340	0.087

† ‡ See Section F Introduction for more information.

FE69

### Electrical Data - Copelametic Large Refrigerant-Cooled Compressors

Model †‡	Volts	PH	Across the Line		Part Winding Start		Winding Resistance Line to Line (Ohms) †
			Max RLA	LRA	Max RLA	LRA	
6DY3A300L-TSK	460	3	67.1	283			0.348
6DY3R32M0-FSD	460	3	50	260	25	156	0.39
6DY3R32M0-TSE	575	3	40	230	20	138	1.16
6DY3R32M0-TSK	208/230	3	105	565	52.5	340	0.087
6DY3R32M0-TSK	460	3	52.5	283			0.348
6DY3R32ME-FSD	460	3	50	260	25	156	0.39
6DY3R32ME-TSE	575	3	40	230	20	138	1.16
6DY3R32ME-TSK	208/230	3	134.3	565	52.5	340	0.087
6DY3R32ME-TSK	460	3	67.1	283			0.348
6DY3R32ML-FSD	460	3	50	260	25	156	0.39
6DY3R32ML-TSE	575	3	40	230	20	138	1.16
6DY3R32ML-TSK	208/230	3	134.3	565	52.5	340	0.087
6DY3R32ML-TSK	460	3	67.1	283			0.348
6RA4-1000-TSE	575	3	17.5	106			1.6
6RA4-1000-TSK	208/230	3	43.6	240	21.8	140	0.259
6RA4-1000-TSK	460	3	21.8	120			1.036
6RA4-100A-TSK	208/230	3	43.6	240	21.8	140	0.259
6RA4-100A-TSK	460	3	21.8	120			1.036
6RA4-2000-FSD	460	3	38.9	135	19.4	82	0.757
6RA4-2000-TSE	575	3	28.2	135	14.1	74	2.2
6RA4-2000-TSK	208/230	3	67.4	308	33.7	188	0.173
6RA4-2000-TSK	460	3	33.7	154			0.69

† ‡ See Section F Introduction for more information.

FE70

### Electrical Data - Copelametic Large Refrigerant-Cooled Compressors

Model †‡	Volts	PH	Across the Line		Part Winding Start		Winding Resistance Line to Line (Ohms) †
			Max RLA	LRA	Max RLA	LRA	
6RA4-200A-TSK	208/230	3	67.4	308	33.7	188	0.173
6RA4-200A-TSK	460	3	33.7	154			0.69
6RA4-200L-TSK	208/230	3	67.4	308	33.7	188	0.173
6RA4-200L-TSK	460	3	33.7	154			0.69
6RA4-3000-ESX	220	3	NA	432			0.108
6RA4-3000-ESX	380	3	NA	249			0.324
6RA4-3000-FSD	460	3	50.6	200	25.3	121	0.475
6RA4-3000-TSE	575	3	42.9	200	21.5	130	1.46
6RA4-3000-TSK	208/230	3	104.3	470	52.5	292	0.108
6RA4-3000-TSK	460	3	52.1	235			0.43
6RA4-300A-TSK	208/230	3	104.3	470	52.5	292	0.108
6RA4-300A-TSK	460	3	52.1	235			0.43
6RA4-300L-TSK	208/230	3	104.3	470	52.5	292	0.108
6RA4-300L-TSK	460	3	52.1	235			0.43
6RA5-1000-TSK	208/230	3	43.6	240	21.8	140	0.259
6RA5-1000-TSK	460	3	21.8	120			1.036
6RA5-2000-TSK	208/230	3	67.4	308	33.7	188	0.173
6RA5-2000-TSK	460	3	33.7	154			0.69
6RB2-1000-TSK	208/230	3	43.3	240	21.7	140	0.259
6RB2-1000-TSK	460	3	21.6	120			1.036
6RB2-2000-FSD	460	3	28.9	135	14.5	82	0.757
6RB2-2000-TSE	575	3	25.4	135	12.7	74	2.2

† ‡ See Section F Introduction for more information.

FE71

### Electrical Data - Copelametic Large Refrigerant-Cooled Compressors

Model †‡	Volts	PH	Across the Line		Part Winding Start		Winding Resistance Line to Line (Ohms) †
			Max RLA	LRA	Max RLA	LRA	
6RB2-2000-TSK	208/230	3	61.4	308	30.7	188	0.173
6RB2-2000-TSK	460	3	30.7	154			0.69
6RB2-200A-TSK	208/230	3	61.4	308	30.7	188	0.173
6RB2-200A-TSK	460	3	30.7	154			0.69
6RE2-2000-FSD	460	3	38.9	135	19.4	82	0.757
6RE2-2000-TSE	575	3	26.8	135	14.1	74	2.2
6RE2-2000-TSK	208/230	3	65.4	308	33.7	188	0.173
6RE2-2000-TSK	460	3	32.5	154			0.69
6RE2-200A-TSK	208/230	3	65.4	308	33.7	188	0.173
6RE2-200A-TSK	460	3	32.5	154			0.69
6RE2-3000-ESX	220	3	NA	432			0.108
6RE2-3000-ESX	380	3	NA	249			0.324
6RE2-3000-FSD	460	3	50	200	25.3	121	0.475
6RE2-3000-TSE	575	3	42.9	200	21.5	130	1.46
6RE2-3000-TSK	208/230	3	104.3	470	52.5	292	0.108
6RE2-3000-TSK	460	3	52.1	235			0.43
6RE2-300A-TSK	208/230	3	104.3	470	52.5	292	0.108
6RE2-300A-TSK	460	3	52.1	235			0.43
6RF5-2000-FSD	460	3	38.9	135	19.4	82	0.757
6RF5-2000-TSE	575	3	28.2	135	14.1	74	2.2
6RH1-2000-TSE	575	3	28.8	135	14.4	74	2.2
6RH1-2000-TSK	208/230	3	72	308	36	188	0.174

† ‡ See Section F Introduction for more information.

FE72

### Electrical Data - Copelametic Large Refrigerant-Cooled Compressors

Model †‡	Volts	PH	Across the Line		Part Winding Start		Winding Resistance Line to Line (Ohms) †
			Max RLA	LRA	Max RLA	LRA	
6RH1-2000-TSK	460	3	36	154			0.696
6RH1-200A-TSK	208/230	3	72	308	36	188	0.174
6RH1-200A-TSK	460	3	36	154			0.696
6RH1-3500-ES8	200/220	3	145.9	633		212	0.225
6RH1-3500-ES8	380	3	85.9	365			0.075
6RH1-3500-FSD	460	3	67.5	225	33.8	150	0.4
6RH1-3500-TSE	575	3	50.2	230	25.1	138	1.16
6RH1-3500-TSK	208/230	3	134.3	565	67.5	340	0.087
6RH1-3500-TSK	460	3	67.1	283			0.348
6RH1-350A-FSD	460	3	67.5	225	33.8	150	0.4
6RH1-350A-TSK	208/230	3	134.3	565	67.5	340	0.087
6RH1-350A-TSK	460	3	67.1	283			0.348
6RH5-2000-TSK	208/230	3	72	308	36	188	0.174
6RH5-2000-TSK	460	3	36	154			0.696
6RH5-3500-FSD	460	3	67.5	225	33.8	150	0.4
6RH5-3500-TSE	575	3	50.2	230	25.1	138	1.16
6RJ1-3000-FSD	460	3	57.5	200	28.8	121	0.475
6RJ1-4000-ES8	200/220	3	160	633		212	0.225
6RJ1-4000-ES8	380	3	89.6	365			0.075
6RJ1-4000-FSD	460	3	64.3	239	32.2	147	0.375
6RJ1-4000-FSU	200	3	170	625	85	388	0.066
6RJ1-4000-TSE	575	3	53.6	225	26.8	140	1.14

† ‡ See Section F Introduction for more information.

FE73

### Electrical Data - Copelametic Large Refrigerant-Cooled Compressors

Model †‡	Volts	PH	Across the Line		Part Winding Start		Winding Resistance Line to Line (Ohms) †
			Max RLA	LRA	Max RLA	LRA	
6RJ1-4000-TSN	230	3	141.4	594	71	340	0.085
6RJ1-4000-TSN	460	3	70.7	297			0.34
6RJ1-400A-FSD	460	3	64.3	239	32.2	147	0.375
6RJ1-400A-FSU	200	3	170	625	85	388	0.066
6RJ1-400A-TSN	230	3	141.4	594	71	340	0.085
6RJ1-400A-TSN	460	3	70.7	297			0.34
6RK2-2000-TSE	575	3	28.8	135	14.4	74	2.2
6RK2-2000-TSK	208/230	3	72	308	36	188	0.174
6RK2-2000-TSK	460	3	36	154			0.696
6RK2-3500-ES8	200/220	3	145.9	633		212	0.225
6RK2-3500-ES8	380	3	82.7	365			0.075
6RK2-3500-FSD	460	3	67.5	225	33.8	150	0.4
6RK2-3500-TSE	575	3	50.2	230	25.1	138	1.16
6RK2-3500-TSK	208/230	3	134.3	565	67.5	340	0.087
6RK2-3500-TSK	460	3	67.1	283			0.348
6RK2-350A-TSK	208/230	3	134.3	565	67.5	340	0.087
6RK2-350A-TSK	460	3	67.1	283			0.348
6RK5-3500-FSD	460	3	67.5	225	33.8	150	0.4
6RK5-3500-TSK	208/230	3	134.3	565	67.5	340	0.087
6RK5-3500-TSK	460	3	67.1	283			0.348
6RL1-2500-ES8	200/220	3	102.3	438		142	0.345
6RL1-2500-ES8	380	3	59.3	251			0.115

† ‡ See Section F Introduction for more information.

FE74

### Electrical Data - Copelametic Large Refrigerant-Cooled Compressors

Model †‡	Volts	PH	Across the Line		Part Winding Start		Winding Resistance Line to Line (Ohms) †
			Max RLA	LRA	Max RLA	LRA	
6RL1-2500-TSE	575	3	34.9	160	17.4	113	1.76
6RL1-2500-TSK	208/230	3	96.9	428	48.5	250	0.132
6RL1-2500-TSK	460	3	48.5	214			0.528
6RL1-250A-TSK	208/230	3	96.9	428	48.5	250	0.132
6RL1-250A-TSK	460	3	48.5	214			0.528
6RL1-250L-TSK	208/230	3	96.9	428	48.5	250	0.132
6RL1-250L-TSK	460	3	48.5	214			0.528
6RL5-2500-TSE	575	3	34.9	160	17.4	113	1.76
6RN2-2000-FSD	460	3	38.9	135	19.4	82	0.757
6RN2-2000-TSE	575	3	26.8	135	14.1	74	2.2
6RN2-2000-TSK	208/230	3	65.4	308	33.7	188	0.173
6RN2-2000-TSK	460	3	32.7	154			0.69
6RN2-200A-TSK	208/230	3	65.4	308	33.7	188	0.173
6RN2-200A-TSK	460	3	32.7	154			0.69
6RN2-3000-ESX	220	3	NA	432			0.108
6RN2-3000-ESX	380	3	NA	249			0.324
6RN2-3000-FSD	460	3	50	200	25.3	121	0.475
6RN2-3000-TSE	575	3	42.9	200	21.5	130	1.46
6RN2-3000-TSK	208/230	3	104.3	470	52.5	292	0.108
6RN2-3000-TSK	460	3	52.1	235			0.43
6RN2-300A-TSK	208/230	3	104.3	470	52.5	292	0.108
6RN2-300A-TSK	460	3	52.1	235			0.43

† ‡ See Section F Introduction for more information.

FE75



### Electrical Data - Copelametic Large Refrigerant-Cooled Compressors

Model †‡	Volts	PH	Across the Line		Part Winding Start		Winding Resistance Line to Line (Ohms) †
			Max RLA	LRA	Max RLA	LRA	
6RN5-3000-TSK	208/230	3	104.3	470	52.5	292	0.108
6RN5-3000-TSK	460	3	52.1	235			0.43
6RP2-2000-TSE	575	3	28.8	135	14.4	74	2.2
6RP2-2000-TSK	208/230	3	72	308	36	188	0.174
6RP2-2000-TSK	460	3	36	154			0.696
6RP2-200A-TSK	208/230	3	72	308	36	188	0.174
6RP2-200A-TSK	460	3	36	154			0.696
6RP2-3500-ES8	200/220	3	145.9	633		212	0.225
6RP2-3500-ES8	380	3	82.7	365			0.075
6RP2-3500-FSD	460	3	67.5	225	33.8	150	0.4
6RP2-3500-TSE	575	3	50.2	230	25.1	138	1.16
6RP2-3500-TSK	208/230	3	134.3	565	67.5	340	0.087
6RP2-3500-TSK	460	3	67.1	283			0.348
6RP2-350A-FSD	460	3	67.5	225	33.8	150	0.4
6RP2-350A-TSK	208/230	3	134.3	565	67.5	340	0.087
6RP2-350A-TSK	460	3	67.1	283			0.348
6RP5-3500-FSD	460	3	67.5	225	33.8	150	0.4
6RP5-3500-TSK	208/230	3	134.3	565	67.5	340	0.087
6RP5-3500-TSK	460	3	67.1	283			0.348
6RR2-4000-ES8	200/220	3	160	633		212	0.225
6RR2-4000-ES8	380	3	89.6	365			0.075
6RR2-4000-FSD	460	3	62	239	32.2	147	0.375

† ‡ See Section F Introduction for more information.

FE76

### Electrical Data - Copelametic Large Refrigerant-Cooled Compressors

Model †‡	Volts	PH	Across the Line		Part Winding Start		Winding Resistance Line to Line (Ohms) †
			Max RLA	LRA	Max RLA	LRA	
6RR2-4000-FSU	200	3	170	625	85	388	0.066
6RR2-4000-TSE	575	3	53.6	225	26.8	140	1.14
6RR2-4000-TSN	230	3	141.4	594	71	340	0.085
6RR2-4000-TSN	460	3	70.7	297			0.34
6RR2-400A-FSD	460	3	62	239	32.2	147	0.375
6RR2-400A-FSU	200	3	170	625	85	388	0.066
6RR2-400A-TSN	230	3	141.4	594	71	340	0.085
6RR2-400A-TSN	460	3	70.7	297			0.34
6RS2-4000-ES8	200/220	3	160	633		212	0.225
6RS2-4000-ES8	380	3	89.6	365			0.075
6RS2-4000-FSD	460	3	62	239	32.2	147	0.375
6RS2-4000-FSU	200	3	170	625	85	388	0.066
6RS2-4000-TSE	575	3	53.6	225	26.8	140	1.14
6RS2-4000-TSN	230	3	141.4	594	71	340	0.085
6RS2-4000-TSN	460	3	70.7	297			0.34
6RS2-400A-FSD	460	3	62	239	32.2	147	0.375
6RS2-400A-FSU	200	3	170	625	85	388	0.066
6RS2-400A-TSN	230	3	141.4	594	71	340	0.085
6RS2-400A-TSN	460	3	70.7	297			0.34
6RT1-3000-FSD	460	3	60.6	200	30	121	0.475
6RT1-3000-TSE	575	3	40	200	20	130	1.46
6RT1-3000-TSK	208/230	3	110.9	470	55.5	292	0.108

† ‡ See Section F Introduction for more information.

FE77

### Electrical Data - Copelametic Large Refrigerant-Cooled Compressors

Model †‡	Volts	PH	Across the Line		Part Winding Start		Winding Resistance Line to Line (Ohms) †
			Max RLA	LRA	Max RLA	LRA	
6RT1-3000-TSK	460	3	55.5	235			0.43
6RT1-300A-TSK	208/230	3	110.9	470	55.5	292	0.108
6RT1-300A-TSK	460	3	55.5	235			0.43
6RT1-300L-TSK	208/230	3	110.9	470	55.5	292	0.108
6RT1-300L-TSK	460	3	55.5	235			0.43
6TM1-2000-TSE	575	3	28.2	135	14.1	74	2.2
6TM1-2000-TSK	208/230	3	65.7	308	32.9	188	0.174
6TM1-2000-TSK	460	3	32.9	154			0.696
8DP1R56M0-FSD	460	3	90.7	510	45.5	330	0.147
8DP1R56M0-TS7	380	3	114	740			0
8DP1R56M0-TSE	575	3	75	405	37.5	262	0.456
8DP1R56M0-TSK	208/230	3	180	1070	90	654	0.039
8DP1R56M0-TSK	460	3	90	535			0.156
8DP3R56M0-FSD	460	3	90.7	510	45.5	330	0.147
8DP3R56M0-TSE	575	3	75	405	37.5	262	0.456
8DP3R56M0-TSK	208/230	3	180	1070	90	654	0.039
8DP3R56M0-TSK	460	3	90	535			0.156
8DP3R56ME-FSD	460	3	90.7	510	45.5	330	0.147
8DP3R56ME-TSE	575	3	75	405	37.5	262	0.456
8DP3R56ME-TSK	208/230	3	180	1070	90	654	0.039
8DP3R56ME-TSK	460	3	90	535			0.156
8DP3R56ML-FSD	460	3	90.7	510	45.5	330	0.147

† ‡ See Section F Introduction for more information.

FE78

### Electrical Data - Copelametic Large Refrigerant-Cooled Compressors

Model †‡	Volts	PH	Across the Line		Part Winding Start		Winding Resistance Line to Line (Ohms) †
			Max RLA	LRA	Max RLA	LRA	
8DP3R56ML-TSE	575	3	75	405	37.5	262	0.456
8DP3R56ML-TSK	208/230	3	180	1070	90	654	0.039
8DP3R56ML-TSK	460	3	90	535			0.156
8DS1R67M0-FSD	460	3	96.4	510	48.3	330	0.147
8DS1R67M0-TS7	380	3	130	740			0
8DS1R67M0-TSE	575	3	80	405	40	262	0.456
8DS1R67M0-TSK	208/230	3	224.3	1070	112	654	0.039
8DS1R67M0-TSK	460	3	112.1	535			0.156
8DS3R67M0-FSD	460	3	96.4	510	48.3	330	0.147
8DS3R67M0-TS7	380	3	130	740			0
8DS3R67M0-TSE	575	3	80	405	40	262	0.456
8DS3R67M0-TSK	208/230	3	224.3	1070	112	654	0.039
8DS3R67M0-TSK	460	3	112.1	535			0.156
8DS3R67ME-FSD	460	3	96.4	510	48.3	330	0.147
8DS3R67ME-TS7	380	3	130	740			0
8DS3R67ME-TSE	575	3	80	405	40	262	0.456
8DS3R67ME-TSK	208/230	3	224.3	1070	112	654	0.039
8DS3R67ME-TSK	460	3	112.1	535			0.156
8DS3R67ML-FSD	460	3	96.4	510	48.3	330	0.147
8DS3R67ML-TSE	575	3	80	405	40	262	0.456
8DS3R67ML-TSK	208/230	3	224.3	1070	112	654	0.039
8DS3R67ML-TSK	460	3	112.1	535			0.156

† ‡ See Section F Introduction for more information.

FE79

### Electrical Data - Copelametic Large Refrigerant-Cooled Compressors

Model †‡	Volts	PH	Across the Line		Part Winding Start		Winding Resistance Line to Line (Ohms) †
			Max RLA	LRA	Max RLA	LRA	
9RS1-1015-TSU	200	3	NA	203			0
9RS1-1505-TSC	208/230	3	56.4	284			0
9RS1-150A-TSC	208/230	3	56.4	284			0
9RS3-1015-TSU	200	3	NA	203			0
9RT1-1505-TSC	208/230	3	56.4	284			0
MRH4-0760-FSC	230	3	NA	130	16.3	85	0.41

† ‡ See Section F Introduction for more information.

FE80

**Electrical Data - Copeland Scroll®**

Model	Volts	PH	Max RLA	LRA	Winding Resistance		Run Cap PN ‡
					Start or Line/Line †	Run	
ZB10KCE-PFJ	265	1	8.2	38	3.4	2.16	014-0064-07
ZB10KCE-PFV	208/230	1	10	41	2.73	1.77	014-0064-06
ZB114KCE-TFD	460	3	28.6	179	0.833	0	
ZB114KCE-TW5	200/230	3	65	340	0.226	0	
ZB114KCE-TW7	380	3	42.9	196	0.56	0	
ZB114KCE-TWD	460	3	32.1	173	0.833	0	
ZB114KCE-TWE	575	3	25.7	132	1.268	0	
ZB114KQ-TFD	460	3	27.9	179	0.833	0	
ZB114KQ-TW5	200/230	3	58.6	340	0.226	0	
ZB114KQ-TW7	380	3	35.7	196	0.56	0	
ZB114KQ-TWD	460	3	28.6	173	0.833	0	
ZB114KQ-TWE	575	3	23.6	132	1.268	0	
ZB114KQE-TFD	460	3	28.6	179	0.833	0	
ZB114KQE-TW5	200/230	3	65	340	0.226	0	
ZB114KQE-TW7	380	3	42.9	196	0.56	0	
ZB114KQE-TWD	460	3	32.1	173	0.833	0	
ZB114KQE-TWE	575	3	25.7	132	1.268	0	
ZB11KCE-PFJ	265	1	8.6	39	3.24	1.81	014-0064-07
ZB11KCE-PFV	208/230	1	10	45	2.27	1.81	014-0064-07
ZB11MA-TW7	380	3	36.4	239	0.52	0	
ZB11MA-TWC	208/230	3	53.6	425	0.19	0	
ZB11MA-TWD	460	3	26.4	187	0.72	0	
ZB11MA-TWE	575	3	23.6	148	1.08	0	
ZB11MC-TW7	380	3	27.9	239	0.52	0	
ZB11MC-TWC	208/230	3	51.6	425	0.19	0	
ZB11MC-TWD	460	3	24.3	187	0.72	0	

‡ † See Section F Introduction for more information.

FF1

**Electrical Data - Copeland Scroll®**

Model	Volts	PH	Max RLA	LRA	Winding Resistance		Run Cap PN ‡
					Start or Line/Line †	Run	
ZB11MC-TWE	575	3	19.4	148	1.08	0	
ZB11MCE-TW7	380	3	32.5	239	0.52	0	
ZB11MCE-TWC	208/230	3	60	425	0.19	0	
ZB11MCE-TWD	460	3	28.2	187	0.72	0	
ZB11MCE-TWE	575	3	22.5	148	1.08	0	
ZB13KCE-PFJ	265	1	10	55	2.75	1.81	014-0064-25
ZB13KCE-PFV	208/230	1	12.9	54	2.67	1.31	014-0064-07
ZB14KCE-PFJ	265	1	11.1	52	2.86	1.5	014-0064-25
ZB14KCE-PFV	208/230	1	13.6	63	2.45	1.17	014-0064-07
ZB15KC-PFJ	265	1	11.4	58	3.34	1.26	014-0064-08
ZB15KC-PFV	208/230	1	13.6	61	2.28	1.01	014-0064-08
ZB15KC-TF5	200/230	3	8.9	55	1.79	0	
ZB15KC-TFD	460	3	4.3	27	7.1	0	
ZB15KCE-PFJ	265	1	13.2	58	3.34	1.26	014-0064-08
ZB15KCE-PFV	208/230	1	15.7	61	2.28	1.01	014-0064-08
ZB15KCE-TF5	200/230	3	8.9	55	1.79	0	
ZB15KCE-TFD	460	3	5	27	7.1	0	
ZB15KQ-PFJ	265	1	11.4	58	3.34	1.26	014-0064-08
ZB15KQ-PFV	208/230	1	13.6	61	2.28	1.01	014-0064-08
ZB15KQ-TF5	200/230	3	8.9	55	1.79	0	
ZB15KQ-TF7	380	3	5	23	7.1	0	
ZB15KQ-TFD	460	3	4.3	27	7.1	0	
ZB15KQE-PFJ	265	1	13.2	58	3.34	1.26	014-0064-08
ZB15KQE-PFV	208/230	1	15.7	61	2.28	1.01	014-0064-08
ZB15KQE-TF5	200/230	3	8.9	55	1.79	0	
ZB15KQE-TF7	380	3	5.1	27	7.1	0	

‡ † See Section F Introduction for more information.

FF2

**Electrical Data - Copeland Scroll®**

Model	Volts	PH	Max RLA	LRA	Winding Resistance		Run Cap PN ‡
					Start or Line/Line †	Run	
ZB15KQE-TFD	460	3	5	27	7.1	0	
ZB19KC-PFJ	265	1	12.9	61	2.23	1.2	014-0064-15
ZB19KC-PFV	208/230	1	15.7	73	2.71	0.908	014-0064-25
ZB19KC-TF5	200/230	3	8.2	63	1.46	0	
ZB19KC-TFD	460	3	4.3	31	5.94	0	
ZB19KCE-PFJ	265	1	13.2	61	2.23	1.2	014-0064-15
ZB19KCE-PFV	208/230	1	17.9	73	2.71	0.908	014-0064-25
ZB19KCE-TF5	200/230	3	8.2	63	1.46	0	
ZB19KCE-TFD	460	3	5	31	5.94	0	
ZB19KQ-PFJ	265	1	12.9	61	2.23	1.2	014-0064-15
ZB19KQ-PFV	208/230	1	15	72.5	1.72	0.905	014-0064-25
ZB19KQ-TF5	200/230	3	10	63	1.46	0	
ZB19KQ-TFD	460	3	4.3	31	5.94	0	
ZB19KQE-PFJ	265	1	14.6	61	2.23	1.2	014-0064-15
ZB19KQE-PFV	208/230	1	17.1	72.5	1.72	0.905	014-0064-25
ZB19KQE-TF5	200/230	3	10	63	1.46	0	
ZB19KQE-TFD	460	3	5	31	5.94	0	
ZB21KC-PFJ	265	1	16.4	83	1.84	0.887	014-0064-16
ZB21KC-PFV	208/230	1	17.9	100	2.82	0.64	014-0064-29
ZB21KC-TF5	200/230	3	11.4	77	1.234	0	
ZB21KC-TFD	460	3	5.7	39	4.83	0	
ZB21KCE-PFJ	265	1	16.4	83	1.84	0.887	014-0064-16
ZB21KCE-PFV	208/230	1	20.7	100	2.82	0.64	014-0064-29
ZB21KCE-TF5	200/230	3	12.1	77	1.234	0	
ZB21KCE-TFD	460	3	6.1	39	4.83	0	
ZB21KQ-PFJ	265	1	16.4	83	1.84	0.887	014-0064-29

‡ † See Section F Introduction for more information.

FF3



**Electrical Data - Copeland Scroll®**

Model	Volts	PH	Max RLA	LRA	Winding Resistance		Run Cap PN ‡
					Start or Line/Line †	Run	
ZB21KQ-PFV	208/230	1	18.4	95	1.39	0.65	014-0064-29
ZB21KQ-TF5	200/230	3	11.4	77	1.234	0	
ZB21KQ-TF7	380	3	7.5	39	4.83	0	
ZB21KQ-TFD	460	3	5.7	39	4.83	0	
ZB21KQE-PFJ	265	1	16.4	83	1.84	0.887	014-0064-29
ZB21KQE-PFV	208/230	1	20.7	95	1.39	0.65	014-0064-29
ZB21KQE-TF5	200/230	3	12.1	77	1.234	0	
ZB21KQE-TF7	380	3	7.4	39	4.83	0	
ZB21KQE-TFD	460	3	7.4	39	4.83	0	
ZB26KC-PFJ	265	1	17.1	98	1.65	0.691	014-0064-18
ZB26KC-PFV	208/230	1	20.7	127	2.15	0.506	014-0064-26
ZB26KC-TF5	200/230	3	13.9	88	0.995	0	
ZB26KC-TFD	460	3	7.1	44	4.03	0	
ZB26KCE-PFJ	265	1	18.9	98	1.65	0.691	014-0064-18
ZB26KCE-PFV	208/230	1	23.6	127	2.15	0.506	014-0064-26
ZB26KCE-TF5	200/230	3	13.9	88	0.995	0	
ZB26KCE-TFD	460	3	7.1	44	4.03	0	
ZB26KQ-PFJ	265	1	17.1	98	1.65	0.691	014-0064-18
ZB26KQ-PFV	208/230	1	20.4	109	1.28	0.54	014-0064-26
ZB26KQ-TF5	200/230	3	13.9	88	0.995	0	
ZB26KQ-TFD	460	3	7.1	44	4.03	0	
ZB26KQE-PFJ	265	1	18.9	98	1.65	0.691	014-0064-18
ZB26KQE-PFV	208/230	1	23.6	109	1.28	0.54	014-0064-26
ZB26KQE-TF5	200/230	3	13.2	88	0.995	0	
ZB26KQE-TFD	460	3	6.4	44	4.03	0	
ZB29KQ-PFJ	265	1	19.3	113	1.67	0.586	014-0064-18

‡ † See Section F Introduction for more information.

FF4

### Electrical Data - Copeland Scroll®

Model	Volts	PH	Max RLA	LRA	Winding Resistance		Run Cap PN ‡
					Start or Line/Line †	Run	
ZB29KQ-PFV	208/230	1	22.1	137	1.34	0.46	014-0064-18
ZB29KQ-TF5	200/230	3	16.4	91	0.994	0	
ZB29KQ-TF7	380	3	9.3	54	2.76	0	
ZB29KQ-TFD	460	3	7.9	50	3.88	0	
ZB29KQE-PFJ	265	1	20	113	1.67	0.586	014-0064-18
ZB29KQE-PFV	208/230	1	25	137	1.34	0.46	014-0064-18
ZB29KQE-TF5	200/230	3	17.1	91	0.994	0	
ZB29KQE-TF7	380	3	9.6	54	2.76	0	
ZB29KQE-TFD	460	3	7.9	50	3.88	0	
ZB30KC-PFV	208/230	1	25	132	2.089	0.454	014-0064-26
ZB30KC-TF5	200/230	3	15	115	0.808	0	
ZB30KC-TF7	380	3	8.6	57	2.77	0	
ZB30KC-TFD	460	3	7.4	47.5	3.58	0	
ZB30KC-TFE	575	3	6.4	40	5.72	0	
ZB30KCE-PFV	208/230	1	26.8	132	2.089	0.454	014-0064-26
ZB30KCE-TF5	200/230	3	15.7	115	0.808	0	
ZB30KCE-TF7	380	3	8.8	57	2.77	0	
ZB30KCE-TFD	460	3	7.5	47.5	3.58	0	
ZB30KCE-TFE	575	3	6.4	40	5.72	0	
ZB30KQ-PFV	208/230	1	25	132	2.089	0.454	014-0064-26
ZB30KQ-TF5	200/230	3	15	115	0.808	0	
ZB30KQ-TFD	460	3	7.4	47.5	3.65	0	
ZB30KQE-PFV	208/230	1	26.8	132	2.089	0.454	014-0064-26
ZB30KQE-TF5	200/230	3	15.7	115	0.808	0	
ZB30KQE-TFD	460	3	8.6	47.5	3.65	0	
ZB38KC-PFV	208/230	1	30.1	175	1.204	0.327	014-0064-27

‡ † See Section F Introduction for more information.

FF5

**Electrical Data - Copeland Scroll®**

Model	Volts	PH	Max RLA	LRA	Winding Resistance		Run Cap PN ‡
					Start or Line/Line †	Run	
ZB38KC-TF5	200/230	3	20.7	115	0.671	0	
ZB38KC-TF7	380	3	10.4	64	2.3	0	
ZB38KC-TFD	460	3	8.9	63	2.65	0	
ZB38KC-TFE	575	3	7.1	50	4.31	0	
ZB38KCE-PFV	208/230	1	31.1	175	1.204	0.327	014-0064-27
ZB38KCE-TF5	200/230	3	22.1	115	0.671	0	
ZB38KCE-TF7	380	3	10.4	64	2.3	0	
ZB38KCE-TFD	460	3	9.6	63	2.65	0	
ZB38KCE-TFE	575	3	7.1	50	4.31	0	
ZB38KQ-PFV	208/230	1	30.1	144	1.328	0.383	014-0064-27
ZB38KQ-TF5	200/230	3	20.7	128	0.726	0	
ZB38KQ-TF7	380	3	10.7	64	2.3	0	
ZB38KQ-TFD	460	3	9.6	63	2.72	0	
ZB38KQE-PFV	208/230	1	30.8	144	1.328	0.383	014-0064-27
ZB38KQE-TF5	200/230	3	24	128	0.726	0	
ZB38KQE-TF7	380	3	12.4	64	2.3	0	
ZB38KQE-TFD	460	3	10	63	2.72	0	
ZB42KC-PFJ	265	1	28.2	160	1.921	0.415	014-0064-16
ZB42KC-PFV	208/230	1	27.9	129	0.779	0.432	014-0064-16
ZB42KCE-PFJ	265	1	31.4	160	1.921	0.415	014-0064-16
ZB42KCE-PFV	208/230	1	31.4	129	0.779	0.432	014-0064-16
ZB45KC-TF5	200/230	3	20.7	156	0.562	0	
ZB45KC-TFD	460	3	11.5	70	2.27	0	
ZB45KC-TFE	575	3	7.9	54	3.56	0	
ZB45KCE-TF5	200/230	3	22.5	156	0.562	0	
ZB45KCE-TFD	460	3	11.5	70	2.27	0	

‡ † See Section F Introduction for more information.

FF6

**Electrical Data - Copeland Scroll®**

Model	Volts	PH	Max RLA	LRA	Winding Resistance		Run Cap PN ‡
					Start or Line/Line †	Run	
ZB45KCE-TFE	575	3	7.9	54	3.56	0	
ZB45KQ-TF5	200/230	3	20.7	156	0.562	0	
ZB45KQ-TF7	380	3	10.7	70	1.92	0	
ZB45KQ-TFD	460	3	11.5	75	2.27	0	
ZB45KQE-TF5	200/230	3	23.1	156	0.562	0	
ZB45KQE-TF7	380	3	12.6	70	1.92	0	
ZB45KQE-TFD	460	3	10.1	75	2.27	0	
ZB48KQ-TF5	200/230	3	25	164	0.501	0	
ZB48KQ-TF7	380	3	12.1	100	1.79	0	
ZB48KQ-TFD	460	3	12.1	100	1.79	0	
ZB48KQE-TF5	200/230	3	26	164	0.501	0	
ZB48KQE-TFD	460	3	13.6	100	1.79	0	
ZB50KC-TF5	200/230	3	28.6	196	0.44	0	
ZB50KC-TF7	380	3	15.7	135	1.174	0	
ZB50KC-TFD	460	3	14.3	100	1.764	0	
ZB50KC-TFE	575	3	9.6	90	2.989	0	
ZB50KCE-TF5	200/230	3	28.6	196	0.44	0	
ZB50KCE-TF7	380	3	18.2	135	1.174	0	
ZB50KCE-TFD	460	3	15	100	1.764	0	
ZB50KCE-TFE	575	3	9.6	90	2.989	0	
ZB50KQ-TF5	200/230	3	28.6	196	0.44	0	
ZB50KQ-TF7	380	3	15.7	135	1.174	0	
ZB50KQ-TFD	460	3	14.3	100	1.764	0	
ZB50KQ-TFE	575	3	9.6	90	2.989	0	
ZB50KQE-TF5	200/230	3	28.6	196	0.44	0	
ZB50KQE-TF7	380	3	18.2	135	1.174	0	

‡ † See Section F Introduction for more information.

FF7

**Electrical Data - Copeland Scroll®**

Model	Volts	PH	Max RLA	LRA	Winding Resistance		Run Cap PN ‡
					Start or Line/Line †	Run	
ZB50KQE-TFD	460	3	15	100	1.764	0	
ZB50KQE-TFE	575	3	9.6	90	2.989	0	
ZB56KA-TW7	380	3	16.6	112	1.03	0	
ZB56KA-TWC	208/230	3	26.4	189	0.37	0	
ZB56KA-TWD	460	3	13.9	99	1.41	0	
ZB56KA-TWE	575	3	10.1	74	2.3	0	
ZB56KC-TW7	380	3	16	112	1.03	0	
ZB56KC-TWC	208/230	3	25.8	189	0.37	0	
ZB56KC-TWD	460	3	13.5	99	1.41	0	
ZB56KC-TWE	575	3	9.9	74	2.3	0	
ZB56KCE-TW7	380	3	18.6	112	1.03	0	
ZB56KCE-TWC	208/230	3	30	189	0.37	0	
ZB56KCE-TWD	460	3	15.7	99	1.41	0	
ZB56KCE-TWE	575	3	9.9	74	2.3	0	
ZB58KC-TF5	200/230	3	32.1	195	0.4	0	
ZB58KC-TF7	380	3	16.7	123	1.051	0	
ZB58KC-TFD	460	3	16.4	95	1.799	0	
ZB58KC-TFE	575	3	12	80	2.55	0	
ZB58KCE-TF5	200/230	3	32.1	195	0.4	0	
ZB58KCE-TF7	380	3	17.1	123	1.051	0	
ZB58KCE-TFD	460	3	16.4	95	1.799	0	
ZB58KCE-TFE	575	3	12.9	80	2.55	0	
ZB58KQ-TF5	200/230	3	32.1	195	0.4	0	
ZB58KQ-TF7	380	3	16.7	123	1.051	0	
ZB58KQ-TFD	460	3	16.4	95	1.799	0	
ZB58KQ-TFE	575	3	12	80	2.55	0	

‡ † See Section F Introduction for more information.

FF8

**Electrical Data - Copeland Scroll®**

Model	Volts	PH	Max RLA	LRA	Winding Resistance		Run Cap PN ‡
					Start or Line/Line †	Run	
ZB58KQE-TF5	200/230	3	32.1	195	0.4	0	
ZB58KQE-TF7	380	3	17.1	123	1.051	0	
ZB58KQE-TFD	460	3	16.4	95	1.799	0	
ZB58KQE-TFE	575	3	12.9	80	2.55	0	
ZB66KC-TF5	200/230	3	33.6	225	0.347	0	
ZB66KC-TF7	380	3	18.6	140	0.93	0	
ZB66KC-TFD	460	3	17.3	114	1.36	0	
ZB66KC-TFE	575	3	13.5	80	2.55	0	
ZB66KCE-TF5	200/230	3	33.6	225	0.347	0	
ZB66KCE-TF7	380	3	20.7	140	0.93	0	
ZB66KCE-TFD	460	3	17.5	114	1.36	0	
ZB66KCE-TFE	575	3	13.5	80	2.55	0	
ZB66KQ-TF5	200/230	3	33.6	225	0.347	0	
ZB66KQ-TF7	380	3	18.6	140	0.93	0	
ZB66KQ-TFD	460	3	17.3	114	1.36	0	
ZB66KQ-TFE	575	3	13.5	80	2.55	0	
ZB66KQE-TF5	200/230	3	33.6	225	0.347	0	
ZB66KQE-TF7	380	3	20.7	140	0.93	0	
ZB66KQE-TFD	460	3	17.5	114	1.36	0	
ZB66KQE-TFE	575	3	13.5	80	2.55	0	
ZB68KA-TW7	380	3	20.7	144	0.78	0	
ZB68KA-TWC	208/230	3	33.3	232	0.29	0	
ZB68KA-TWD	460	3	17	125	1.11	0	
ZB68KA-TWE	575	3	12.9	100	1.86	0	
ZB75KA-TW7	380	3	25.4	151	0.72	0	
ZB75KA-TWC	208/230	3	37.4	278	0.26	0	

‡ † See Section F Introduction for more information.

FF9

**Electrical Data - Copeland Scroll®**

Model	Volts	PH	Max RLA	LRA	Winding Resistance		Run Cap PN ‡
					Start or Line/Line †	Run	
ZB75KA-TWD	460	3	18.4	127	1.02	0	
ZB75KA-TWE	575	3	15.2	100	1.7	0	
ZB75KC-TW7	380	3	20.6	151	0.72	0	
ZB75KC-TWC	208/230	3	37.5	278	0.26	0	
ZB75KC-TWD	460	3	18.1	127	1.02	0	
ZB75KC-TWE	575	3	13.9	100	1.7	0	
ZB75KCE-TW7	380	3	23.9	151	0.72	0	
ZB75KCE-TWC	208/230	3	43.6	278	0.26	0	
ZB75KCE-TWD	460	3	21.1	127	1.02	0	
ZB75KCE-TWE	575	3	16.1	100	1.7	0	
ZB76KC-TF5	200/230	3	41.4	239	0.306	0	
ZB76KC-TF7	380	3	23.6	145	0.85	0	
ZB76KC-TFD	460	3	19.2	125	1.227	0	
ZB76KC-TFE	575	3	13.8	80	2.55	0	
ZB76KCE-TF5	200/230	3	41.4	239	0.306	0	
ZB76KCE-TF7	380	3	23.6	145	0.85	0	
ZB76KCE-TFD	460	3	20	125	1.227	0	
ZB76KCE-TFE	575	3	13.8	80	2.55	0	
ZB76KQ-TF5	200/230	3	41.4	239	0.306	0	
ZB76KQ-TF7	380	3	23.6	145	0.85	0	
ZB76KQ-TFD	460	3	19.2	125	1.227	0	
ZB76KQ-TFE	575	3	13.8	80	2.55	0	
ZB76KQE-TF5	200/230	3	41.4	239	0.306	0	
ZB76KQE-TF7	380	3	23.6	145	0.85	0	
ZB76KQE-TFD	460	3	20	125	1.227	0	
ZB76KQE-TFE	575	3	13.8	80	2.55	0	

‡ † See Section F Introduction for more information.

FF10

**Electrical Data - Copeland Scroll®**

Model	Volts	PH	Max RLA	LRA	Winding Resistance		Run Cap PN ‡
					Start or Line/Line †	Run	
ZB88KC-TF5	200/230	3	47.1	245	0.282	0	
ZB88KC-TF7	380	3	24.4	145	0.85	0	
ZB88KC-TFD	460	3	19.6	125	1.227	0	
ZB88KC-TFE	575	3	15.9	100	1.87	0	
ZB88KCE-TF5	200/230	3	47.1	245	0.282	0	
ZB88KCE-TF7	380	3	24.4	145	0.85	0	
ZB88KCE-TFD	460	3	20.7	125	1.227	0	
ZB88KCE-TFE	575	3	15.9	100	1.87	0	
ZB88KQ-TF5	200/230	3	47.1	245	0.282	0	
ZB88KQ-TF7	380	3	24.4	145	0.85	0	
ZB88KQ-TFD	460	3	20.7	125	1.227	0	
ZB88KQ-TFE	575	3	15.9	100	1.87	0	
ZB88KQE-TF5	200/230	3	47.1	245	0.282	0	
ZB88KQE-TF7	380	3	24.4	145	0.85	0	
ZB88KQE-TFD	460	3	20.7	125	1.227	0	
ZB88KQE-TFE	575	3	15.9	100	1.87	0	
ZB92KA-TW7	380	3	27.9	195	0.57	0	
ZB92KA-TWC	208/230	3	45.7	350	0.22	0	
ZB92KA-TWD	460	3	24.3	158	0.83	0	
ZB92KA-TWE	575	3	19.3	125	1.28	0	
ZB92KC-TW7	380	3	24.3	195	0.57	0	
ZB92KC-TWC	208/230	3	45.4	350	0.22	0	
ZB92KC-TWD	460	3	21.5	158	0.83	0	
ZB92KC-TWE	575	3	17.2	125	1.28	0	
ZB92KCE-TW7	380	3	28.2	195	0.57	0	
ZB92KCE-TWC	208/230	3	52.9	350	0.22	0	

‡ † See Section F Introduction for more information.

FF11



**Electrical Data - Copeland Scroll®**

Model	Volts	PH	Max RLA	LRA	Winding Resistance		Run Cap PN ‡
					Start or Line/Line †	Run	
ZB92KCE-TWD	460	3	25	158	0.83	0	
ZB92KCE-TWE	575	3	20	125	1.28	0	
ZB95KCE-TFD	460	3	26.4	150	1.1	0	
ZB95KCE-TW5	200/230	3	61.4	300	0.227	0	
ZB95KCE-TW7	380	3	35	139	0.853	0	
ZB95KCE-TWD	460	3	31.4	150	1.108	0	
ZB95KCE-TWE	575	3	22.9	109	1.518	0	
ZB95KQ-TFD	460	3	25	150	1.1	0	
ZB95KQ-TW5	200/230	3	53.6	300	0.227	0	
ZB95KQ-TW7	380	3	28.6	139	0.853	0	
ZB95KQ-TWD	460	3	24.3	150	1.108	0	
ZB95KQ-TWE	575	3	20.7	109	1.518	0	
ZB95KQE-TFD	460	3	26.4	150	1.1	0	
ZB95KQE-TW5	200/230	3	61.4	300	0.227	0	
ZB95KQE-TW7	380	3	35	139	0.853	0	
ZB95KQE-TWD	460	3	31.4	150	1.108	0	
ZB95KQE-TWE	575	3	22.9	109	1.518	0	
ZBD30KC-TF5	200/230	3	15	99	0.911	0	
ZBD30KC-TF7	380	3	8	57	2.78	0	
ZBD30KC-TFD	460	3	7.4	47.5	3.64	0	
ZBD30KCE-TF5	200/230	3	15.7	99	0.911	0	
ZBD30KCE-TFD	460	3	7.4	47.5	3.64	0	
ZBD45KC-TF5	200/230	3	20.7	156	0.562	0	
ZBD45KC-TF7	380	3	12.5	70	1.92	0	
ZBD45KC-TFD	460	3	10	70	2.27	0	
ZBD45KCE-TF5	200/230	3	22.5	156	0.562	0	

‡ † See Section F Introduction for more information.

FF12

**Electrical Data - Copeland Scroll®**

Model	Volts	PH	Max RLA	LRA	Winding Resistance		Run Cap PN ‡
					Start or Line/Line †	Run	
ZBD45KCE-TFD	460	3	10	70	2.27	0	
ZBH30KJE-TF5	200/230	3	15	99	0.911	0	
ZBH30KJE-TF7	380	3	8.2	57	0.911	0	
ZBH30KJE-TFD	460	3	8.2	49.5	3.64	0	
ZBH30KJE-TFE	575	3	6.4	40	5.72	0	
ZBH38KJE-TF5	200/230	3	21.4	123	0.686	0	
ZBH38KJE-TF7	380	3	11.4	64	0.686	0	
ZBH38KJE-TFD	460	3	9.6	62	2.75	0	
ZBH45KJE-TF5	200/230	3	23.9	156	0.501	0	
ZBH45KJE-TF7	380	3	12.9	70	2.27	0	
ZBH45KJE-TFD	460	3	9.3	70	2.27	0	
ZC40C1G-TF5	200/230	3	12.9	108	0.803	0	
ZC40C1G-TFD	460	3	6.9	47.5	3.65	0	
ZC60C1G-TF5	200/230	3	21.4	156	0.501	0	
ZC60C1G-TFD	460	3	8.9	70	2.27	0	
ZCH22C1G-PFJ	265	1	10.7	47	2.85	1.62	014-0064-14
ZCH22C1G-PFV	208/230	1	12.9	47	2.06	1.18	014-0064-25
ZCH48C2G-TF5	200/230	3	16.4	91	0.994	0	
ZCH48C2G-TFD	460	3	7.9	50	3.88	0	
ZCH68C1G-TF5	200/230	3	24.3	164	0.501	0	
ZCH68C1G-TFD	460	3	10	75	2.27	0	
ZCH68C2G-TFD	460	3	10	75	2.27	0	
ZCH72C2G-TF5	200/230	3	22.9	156	0.501	0	
ZCH72C2G-TFD	460	3	10	75	2.27	0	
ZCH81C2G-TF5	200/230	3	23.6	164	0.501	0	
ZCH81C2G-TFD	460	3	13.6	100	1.79	0	

‡ † See Section F Introduction for more information.

FF13

**Electrical Data - Copeland Scroll®**

Model	Volts	PH	Max RLA	LRA	Winding Resistance		Run Cap PN ‡
					Start or Line/Line †	Run	
ZCH94C1G-TF5	200/230	3	NA	195	1.979	0.553	
ZCH94C1G-TFD	460	3	NA	95	1.799	0	
ZF06K4-PFV	208/230	1	13.6	61	2.28	1.01	014-0064-08
ZF06K4-TF5	200/230	3	7.9	55	1.79	0	
ZF06K4-TFD	460	3	3.6	27	7.1	0	
ZF06K4E-PFV	208/230	1	13.6	61	2.28	1.01	014-0064-08
ZF06K4E-TF5	200/230	3	9.3	55	1.79	0	
ZF06K4E-TFD	460	3	4.3	27	7.1	0	
ZF08K4-PFV	208/230	1	16.4	73	1.72	0.833	014-0064-25
ZF08K4-TF5	200/230	3	7.9	63	1.46	0	
ZF08K4-TFD	460	3	3.9	31	5.94	0	
ZF08K4E-PFV	208/230	1	16.4	73	1.72	0.833	014-0064-25
ZF08K4E-TF5	200/230	3	9.6	63	1.46	0	
ZF08K4E-TFD	460	3	5	31	5.94	0	
ZF09K4-PFV	208/230	1	17.9	88	1.46	0.691	014-0064-29
ZF09K4-TF5	200/230	3	10	77	1.234	0	
ZF09K4-TFD	460	3	5	39	4.83	0	
ZF09K4-TFE	575	3	4.3	31	7.89	0	
ZF09K4E-PFV	208/230	1	16.4	88	1.46	0.691	014-0064-29
ZF09K4E-TF5	200/230	3	9.6	77	1.234	0	
ZF09K4E-TFD	460	3	5.7	39	4.83	0	
ZF09K4E-TFE	575	3	4.3	31	7.89	0	
ZF11K4-PFV	208/230	1	20.7	109	1.28	0.54	014-0064-26
ZF11K4-TF5	200/230	3	12.5	88	0.995	0	
ZF11K4-TFD	460	3	6.4	44	4.03	0	
ZF11K4E-PFV	208/230	1	20.7	109	1.28	0.54	014-0064-26

‡ † See Section F Introduction for more information.

FF14

**Electrical Data - Copeland Scroll®**

Model	Volts	PH	Max RLA	LRA	Winding Resistance		Run Cap PN ‡
					Start or Line/Line †	Run	
ZF11K4E-TF5	200/230	3	8.9	88	0.995	0	
ZF11K4E-TFD	460	3	7.1	44	4.03	0	
ZF11K4E-TFE	575	3	5	34	6.28	0	
ZF13K4-TF5	200/230	3	15	99	0.911	0	
ZF13K4-TF7	380	3	7.1	57	2.78	0	
ZF13K4-TFD	460	3	6.8	49.5	3.64	0	
ZF13K4E-PFV	208/230	1	26.8	129	0.779	0.432	014-0064-26
ZF13K4E-TF5	200/230	3	15	99	0.911	0	
ZF13K4E-TF7	380	3	8.2	57	2.78	0	
ZF13K4E-TFD	460	3	8.2	49.5	3.64	0	
ZF13K4E-TFE	575	3	8.2	40	5.72	0	
ZF13KVE-TF5	200/230	3	19.3	123	0.686	0	
ZF13KVE-TF7	380	3	10.7	64	2.28	0	
ZF13KVE-TFD	460	3	9.3	62	2.75	0	
ZF13KVE-TFE	575	3	7.9	50	4.31	0	
ZF15K4-TF5	200/230	3	16.4	123	0.686	0	
ZF15K4-TF7	380	3	9.5	64	2.28	0	
ZF15K4-TFD	460	3	8.6	62	2.75	0	
ZF15K4E-PFV	208/230	1	31.8	169	0.605	0.329	014-0064-27
ZF15K4E-TF5	200/230	3	21.4	123	0.686	0	
ZF15K4E-TF7	380	3	9.5	64	2.28	0	
ZF15K4E-TFD	460	3	9.6	62	2.75	0	
ZF15K4E-TFE	575	3	7.9	50	4.31	0	
ZF18K4-TF5	200/230	3	20	156	0.501	0	
ZF18K4-TF7	380	3	11.3	70	1.92	0	
ZF18K4-TFD	460	3	8.9	70	2.27	0	

‡ † See Section F Introduction for more information.

FF15

**Electrical Data - Copeland Scroll®**

Model	Volts	PH	Max RLA	LRA	Winding Resistance		Run Cap PN ‡
					Start or Line/Line †	Run	
ZF18K4-TFE	575	3	7.1	54	3.56	0	
ZF18K4E-TF5	200/230	3	23.9	156	0.501	0	
ZF18K4E-TF7	380	3	12.6	70	1.92	0	
ZF18K4E-TFD	460	3	9.3	70	2.27	0	
ZF18K4E-TFE	575	3	7.9	54	3.56	0	
ZF18KVE-TF5	200/230	3	23.9	156	0.562	0	
ZF18KVE-TF7	380	3	12.9	70	1.92	0	
ZF18KVE-TFD	460	3	9.3	70	2.27	0	
ZF18KVE-TFE	575	3	9.3	54	3.56	0	
ZF24K4-TW7	380	3	14.3	112	1.03	0	
ZF24K4-TWC	208/230	3	22.9	189	0.37	0	
ZF24K4-TWD	460	3	11.4	99	1.41	0	
ZF24K4-TWE	575	3	8.9	74	2.3	0	
ZF24K4E-TW7	380	3	18.6	112	1.03	0	
ZF24K4E-TWC	208/230	3	30	189	0.37	0	
ZF24K4E-TWD	460	3	15.7	99	1.41	0	
ZF24K4E-TWE	575	3	8.9	74	2.3	0	
ZF24KVE-TW7	380	3	18.6	112	1.03	0	
ZF24KVE-TWC	208/230	3	30	189	0.37	0	
ZF24KVE-TWD	460	3	15.7	99	1.41	0	
ZF24KVE-TWE	575	3	11.4	74	2.3	0	
ZF33K4-TW7	380	3	16.6	151	0.72	0	
ZF33K4-TWC	208/230	3	30.1	278	0.26	0	
ZF33K4-TWD	460	3	16.4	127	1.02	0	
ZF33K4-TWE	575	3	11.6	100	1.7	0	
ZF33K4E-TW7	380	3	23.9	151	0.72	0	

‡ † See Section F Introduction for more information.

FF16

**Electrical Data - Copeland Scroll®**

Model	Volts	PH	Max RLA	LRA	Winding Resistance		Run Cap PN ‡
					Start or Line/Line †	Run	
ZF33K4E-TWC	208/230	3	43.6	278	0.26	0	
ZF33K4E-TWD	460	3	21.1	127	1.02	0	
ZF33K4E-TWE	575	3	16.1	100	1.7	0	
ZF33KVE-TW7	380	3	23.9	151	0.72	0	
ZF33KVE-TWC	208/230	3	43.6	278	0.26	0	
ZF33KVE-TWD	460	3	21.1	127	1.02	0	
ZF33KVE-TWE	575	3	16.1	100	1.7	0	
ZF40K4-TW7	380	3	22.9	195	0.57	0	
ZF40K4-TWC	208/230	3	40.7	350	0.22	0	
ZF40K4-TWD	460	3	20	158	0.83	0	
ZF40K4-TWE	575	3	15.4	125	1.28	0	
ZF40K4E-TW7	380	3	28.2	195	0.57	0	
ZF40K4E-TWC	208/230	3	52.9	350	0.22	0	
ZF40K4E-TWD	460	3	25	158	0.83	0	
ZF40K4E-TWE	575	3	20	125	1.28	0	
ZF40KVE-TW7	380	3	28.2	195	0.57	0	
ZF40KVE-TWC	208/230	3	52.9	350	0.22	0	
ZF40KVE-TWD	460	3	25	158	0.83	0	
ZF40KVE-TWE	575	3	20	125	1.28	0	
ZF48K4-TW7	380	3	25	239	0.52	0	
ZF48K4-TWC	208/230	3	48.2	425	0.19	0	
ZF48K4-TWD	460	3	22.1	187	0.72	0	
ZF48K4-TWE	575	3	17.9	148	1.1	0	
ZF48K4E-TW7	380	3	32.5	239	0.52	0	
ZF48K4E-TWC	208/230	3	60	425	0.19	0	
ZF48K4E-TWD	460	3	28.2	187	0.72	0	

‡ † See Section F Introduction for more information.

FF17

**Electrical Data - Copeland Scroll®**

Model	Volts	PH	Max RLA	LRA	Winding Resistance		Run Cap PN ‡
					Start or Line/Line †	Run	
ZF48K4E-TWE	575	3	22.5	148	1.1	0	
ZF48KVE-TW7	380	3	32.5	239	0.52	0	
ZF48KVE-TWC	208/230	3	60	425	0.19	0	
ZF48KVE-TWD	460	3	28.2	187	0.72	0	
ZF48KVE-TWE	575	3	22.5	148	1.1	0	
ZFD18KVE-TF5	200/230	3	24.3	156	0.501	0	
ZFD18KVE-TF7	380	3	12.5	70	1.92	0	
ZFD18KVE-TFD	460	3	10.7	70	2.27	0	
ZH09KVE-TFD	460	3	NA	39	4.83	0	
ZH11M4E-TWD	460	3	30.7	187	0.72	0	
ZH13KVE-PFJ	265	1	NA	NA	1.224	0.417	014-0064-26
ZH13KVE-TFD	460	3	9.6	62	2.75	0	
ZH15K4E-PFJ	265	1	12.1	58	3.34	1.26	014-0064-14
ZH15K4E-TFD	460	3	4.3	27	7.1	0	
ZH18KVE-TF5	200/230	3	21.4	156	0.562	0	
ZH18KVE-TFD	460	3	10.4	100	1.79	0	
ZH19K4E-PFJ	265	1	16.8	76	1.89	0.981	014-0064-15
ZH19K4E-TFD	460	3	5	31	5.94	0	
ZH21K4E-PFJ	265	1	16.1	75	2.07	0.937	014-0064-16
ZH21K4E-TFD	460	3	5.7	35	2.74	0	
ZH24KVE-TWD	460	3	17.7	99	1.394	0	
ZH26K4E-PFJ	265	1	19.6	98	1.65	0.691	014-0064-18
ZH26K4E-TFD	460	3	7.1	44	1.85	0	
ZH30K4E-PFJ	265	1	19.3	110	1.947	0.599	014-0064-15
ZH30K4E-TFD	460	3	8.2	49.5	3.64	0	
ZH33KVE-TWD	460	3	20.1	127	1.002	0	

‡ † See Section F Introduction for more information.

FF18

**Electrical Data - Copeland Scroll®**

Model	Volts	PH	Max RLA	LRA	Winding Resistance		Run Cap PN ‡
					Start or Line/Line †	Run	
ZH38K4E-TFD	460	3	9.6	62	2.75	0	
ZH40KVE-TWD	460	3	23.1	158	0.83	0	
ZH45K4E-TFD	460	3	9.6	70	2.27	0	
ZH48KVE-TWD	460	3	27.1	198	0.72	0	
ZH56K4E-TWD	460	3	16.4	94	1.394	0	
ZH75K4E-TWD	460	3	22.9	127	1.002	0	
ZH92K4E-TWD	460	3	27.1	158	0.83	0	
ZM18K4E-TFD	460	3	9.3	70	2.27	0	
ZMD18KVE-TFD	460	3	10.7	70	2.27	0	
ZMD26KVE-TFD	460	3	10.4	75	2.26	0	
ZNH13C2A-KXX	275	3	NA	125	0.458	0	
ZNH16C2A-KXX	275	3	NA	125	0.458	0	
ZNH22C2A-KXX	275	3	NA	125	0.458	0	
ZNH22C3A-KXX	275	3	NA	110	0.571	0	
ZNH28C2A-KXX	275	3	NA	125	0.458	0	
ZO104KCE-TFD	460	3	NA	NA	2.26	0	
ZO34K3E-TFD	460	3	NA	27	7.15	0	
ZO45K3E-TFD	460	3	NA	35	5.35	0	
ZO58K3E-TFD	460	3	NA	46	3.88	0	
ZP103KCE-TF5	200/230	3	33.6	225	0.347	0	
ZP103KCE-TFD	460	3	18.6	114	1.36	0	
ZP103KCE-TFE	575	3	13.6	80	2.55	0	
ZP120KCE-TF5	200/230	3	37.1	239	0.306	0	
ZP120KCE-TF7	380	3	26.4	145	0.85	0	
ZP120KCE-TFD	460	3	20	125	1.227	0	
ZP120KCE-TFE	575	3	14.3	80	2.55	0	

‡ † See Section F Introduction for more information.

FF19



**Electrical Data - Copeland Scroll®**

Model	Volts	PH	Max RLA	LRA	Winding Resistance		Run Cap PN ‡
					Start or Line/Line †	Run	
ZP137KCE-TF5	200/230	3	53.6	245	0.282	0	
ZP137KCE-TF7	380	3	26.4	145	0.85	0	
ZP137KCE-TFD	460	3	20.7	125	1.227	0	
ZP137KCE-TFE	575	3	16.4	100	1.87	0	
ZP154KCE-TF7	380	3	27.1	138	0.845	0	
ZP154KCE-TFD	460	3	25	150	1.1	0	
ZP154KCE-TW5	200/230	3	57.1	300	0.227	0	
ZP154KCE-TW7	380	3	30	139	0.853	0	
ZP154KCE-TWD	460	3	25.7	150	1.108	0	
ZP154KCE-TWE	575	3	22.1	109	1.518	0	
ZP16K3E-PFV	208/230	1	11.4	51	1.87	1.32	014-0064-08
ZP16K5E-PFJ	265	1	7.9	43	1.79	1.79	014-0064-07
ZP16K5E-PFV	208/230	1	10	48	2.303	1.53	014-0064-06
ZP180KCE-TW7	380	3	40.1	239	0.52	0	
ZP180KCE-TWC	208/230	3	59.1	425	0.19	0	
ZP180KCE-TWD	460	3	26.4	187	0.72	0	
ZP180KCE-TWE	575	3	26	148	1.1	0	
ZP182KCE-TFD	460	3	29.3	179	0.833	0	
ZP182KCE-TW5	200/230	3	62.1	340	0.226	0	
ZP182KCE-TW7	380	3	37.9	196	0.56	0	
ZP182KCE-TWD	460	3	30	173	0.833	0	
ZP182KCE-TWE	575	3	26.4	132	1.268	0	
ZP20K3E-PFJ	265	1	12.1	58	3.34	1.26	014-0064-08
ZP20K3E-PFV	208/230	1	14.3	60	1.856	1.073	014-0064-07
ZP20K3E-TF5	200/230	3	8.6	55	1.79	0	
ZP20K3E-TFD	460	3	4.4	22.4	8.64	0	

‡ † See Section F Introduction for more information.

FF20

**Electrical Data - Copeland Scroll®**

Model	Volts	PH	Max RLA	LRA	Winding Resistance		Run Cap PN ‡
					Start or Line/Line †	Run	
ZP20K5E-PFJ	265	1	10	54	2.17	1.48	014-0064-08
ZP20K5E-PFV	208/230	1	15	58.3	1.47	1.23	014-0064-07
ZP21K5E-PFJ	265	1	10.7	54	2.17	1.48	014-0064-08
ZP21K5E-PFV	208/230	1	14.3	58.3	1.47	1.23	014-0064-08
ZP22KCE-PFV	208/230	1	15	61	2.28	1.01	014-0064-08
ZP235KCE-TW5	200/230	3	82.4	505	0.14	0	
ZP235KCE-TW7	380	3	42.6	290	0.44	0	
ZP235KCE-TWC	230	3	82.4	505	0.14	0	
ZP235KCE-TWD	460	3	33.9	225	0.63	0	
ZP235KCE-TWE	575	3	27.4	180	0.97	0	
ZP23K3E-PFJ	265	1	12.1	58	3.34	1.26	014-0064-14
ZP23K3E-PFV	208/230	1	15	61	2.28	1.01	014-0064-08
ZP23K3E-TF5	200/230	3	9.3	63	1.46	0	
ZP23K3E-TFD	460	3	5	27	7.1	0	
ZP24K5E-PFJ	265	1	12.1	60	2.6	1.33	014-0064-08
ZP24K5E-PFV	208/230	1	14.3	64	1.57	1.12	014-0064-08
ZP24K5E-TF5	200/230	3	9.3	58			
ZP24K5E-TFD	460	3	5.7	28			
ZP24K5E-TFE	575	3	3.7	22.5			
ZP25K5E-PFJ	265	1	12.5	60	2.6	1.33	014-0064-08
ZP25K5E-PFV	208/230	1	15.7	73	1.78	0.98	014-0064-08
ZP25K5E-TF5	200/230	3	9.9	58			
ZP25K5E-TFE	575	3	3.9	24			
ZP26K3E-PFJ	265	1	13.9	61	2.23	1.2	014-0064-15
ZP26K3E-PFV	208/230	1	16.4	72.5	1.72	0.905	014-0064-25
ZP26K3E-TF5	200/230	3	11.6	63	1.46	0	

‡ † See Section F Introduction for more information.

FF21

**Electrical Data - Copeland Scroll®**

Model	Volts	PH	Max RLA	LRA	Winding Resistance		Run Cap PN ‡
					Start or Line/Line †	Run	
ZP26KCE-PFV	208/230	1	17.1	73	2.71	0.908	014-0064-13
ZP285KCE-TW5	200/230	3	99.3	500	0.112	0	
ZP285KCE-TW7	380	3	60.7	305	0.311	0	
ZP285KCE-TWC	208/230	3	99.3	500	0.112	0	
ZP285KCE-TWD	460	3	47.9	250	0.45	0	
ZP285KCE-TWE	575	3	35.7	198	0.701	0	
ZP28K5E-PFV	208/230	1	17.9	77	1.44	0.9	014-0064-25
ZP28K5E-TF5	200/230	3	11.1	71			
ZP295KCE-TW7	380	3	57.9	353	0.36	0	
ZP295KCE-TWC	208/230	3	95	605	0.12	0	
ZP295KCE-TWD	460	3	46.7	272	0.51	0	
ZP295KCE-TWE	575	3	38.7	240	0.805	0	
ZP29K5E-PFJ	265	1	13.6	72	1.22	1.15	014-0064-26
ZP29K5E-PFV	208/230	1	15.7	77	1.44	0.9	014-0064-25
ZP29K5E-TF5	200/230	3	10	71			
ZP29K5E-TFD	460	3	6.3	38			
ZP29K5E-TFE	575	3	4.2	36.5			
ZP31K5E-PFJ	265	1	15	72	1.22	1.15	014-0064-26
ZP31K5E-PFV	208/230	1	18.6	79	1.465	0.869	014-0064-25
ZP31K5E-TF5	200/230	3	11.6	73			
ZP31K5E-TFD	460	3	6.4	38			
ZP31K5E-TFE	575	3	4.2	36.5			
ZP32K3E-PFJ	265	1	17.1	83	1.84	0.887	014-0064-16
ZP32K3E-PFV	208/230	1	17.1	83	1.69	0.722	014-0064-25
ZP32K3E-TF5	200/230	3	12.9	77	1.38	0	
ZP32K3E-TFD	460	3	5.7	35	5.35	0	

‡ † See Section F Introduction for more information.

FF22

**Electrical Data - Copeland Scroll®**

Model	Volts	PH	Max RLA	LRA	Winding Resistance		Run Cap PN ‡
					Start or Line/Line †	Run	
ZP32K3E-TFE	575	3	4.8	31	7.89	0	
ZP32KCE-PFV	208/230	1	20	100	2.82	0.64	014-0064-14
ZP34K5E-PFV	208/230	1	20	112	1.253	0.556	014-0064-25
ZP34K5E-TF5	200/230	3	14.7	88	0.995	0	
ZP34K5E-TFD	460	3	6.6	44	4.03	0	
ZP36K3E-PFJ	265	1	20	98	1.65	0.691	014-0064-18
ZP36K3E-PFV	208/230	1	20.7	105	1.36	0.605	014-0064-28
ZP36K3E-TF5	200/230	3	15	88	0.995	0	
ZP36K3E-TFD	460	3	7.1	39	4.83	0	
ZP36K3E-TFE	575	3	5.7	34	6.28	0	
ZP36K5E-PFJ	265	1	17.9	87	1.167	0.719	014-0064-26
ZP36K5E-PFV	208/230	1	20	112	1.253	0.556	014-0064-25
ZP36K5E-TF5	200/230	3	15.1	88	0.995	0	
ZP36K5E-TFD	460	3	6.6	44	4.03	0	
ZP36K5E-TFE	575	3	5.5	34	6.28	0	
ZP385KCE-TW5	200/230	3	122.1	599	0.096	0	
ZP385KCE-TW7	380	3	77.1	358	0.244	0	
ZP385KCE-TWC	208/230	3	122.1	599	0.096	0	
ZP385KCE-TWD	460	3	60.7	310	0.349	0	
ZP385KCE-TWE	575	3	55	239	0.555	0	
ZP38K3E-PFV	208/230	1	21.4	104	1.38	0.57	014-0064-28
ZP38K3E-TF5	200/230	3	15	88	0.995	0	
ZP38K3E-TFD	460	3	7.9	46	3.88	0	
ZP38K3E-TFE	575	3	5.6	34	6.28	0	
ZP38K5E-PFV	208/230	1	22.1	109	1.215	0.552	014-0064-25
ZP38K5E-TF5	200/230	3	15.1	83.1	1.034	0	

‡ † See Section F Introduction for more information.

FF23

### Electrical Data - Copeland Scroll®

Model	Volts	PH	Max RLA	LRA	Winding Resistance		Run Cap PN ‡
					Start or Line/Line †	Run	
ZP38K5E-TFD	460	3	6.8	41	4.17	0	
ZP38KCE-PFV	208/230	1	22.1	131	1.78	0.525	014-0064-14
ZP39K5E-PFV	208/230	1	22.1	109	1.215	0.552	014-0064-25
ZP39K5E-TF5	200/230	3	14.6	83.1	1.034	0	
ZP39K5E-TFD	460	3	6.8	41	4.17	0	
ZP41K3E-PFJ	265	1	20	98	1.65	0.691	014-0064-18
ZP41K3E-PFV	208/230	1	22.9	109	1.28	0.54	014-0064-26
ZP41K3E-TF5	200/230	3	16.2	91	0.994	0	
ZP41K3E-TFD	460	3	7.9	46	3.88	0	
ZP41K3E-TFE	575	3	5.7	34	6.28	0	
ZP42K5E-PFJ	265	1	18.1	98	0.885	0.701	014-0064-27
ZP42K5E-PFV	208/230	1	24.3	117	0.817	0.517	014-0064-34
ZP42K5E-TF5	200/230	3	15.3	83.1	1.034	0	
ZP42K5E-TFD	460	3	6.9	41	4.17	0	
ZP44K3E-PFV	208/230	1	25.7	134	1.45	0.49	014-0064-26
ZP44K3E-TF5	200/230	3	17.9	91	0.994	0	
ZP44K3E-TFD	460	3	7.9	46	3.88	0	
ZP44K3E-TFE	575	3	6.2	37	6.21	0	
ZP44KCE-PFV	208/230	1	27.1	131	1.85	0.475	014-0064-29
ZP50K3E-PFJ	265	1	23.6	133	0.76	0.49	014-0064-27
ZP50K3E-PFV	208/230	1	30	145	0.593	0.398	014-0064-27
ZP50K3E-TF5	200/230	3	19.6	123	0.686	0	
ZP50K3E-TFD	460	3	10.7	62	2.8	0	
ZP50K3E-TFE	575	3	6.8	40	5.72	0	
ZP51K5E-PFV	208/230	1	29.4	134	0.792	0.453	014-0064-34
ZP51K5E-TF5	200/230	3	17.8	110	0.68	0	

‡ † See Section F Introduction for more information.

FF24

**Electrical Data - Copeland Scroll®**

Model	Volts	PH	Max RLA	LRA	Winding Resistance		Run Cap PN ‡
					Start or Line/Line †	Run	
ZP51K5E-TFD	460	3	8.6	52	3.199	0	
ZP51K5E-TFE	575	3	6.4	38.9	5.4	0	
ZP54K3E-PFV	208/230	1	30.7	158	0.553	0.37	014-0064-27
ZP54K3E-TF5	200/230	3	20.2	137	0.612	0	
ZP54K3E-TFD	460	3	10	62	2.8	0	
ZP54K3E-TFE	575	3	7.6	50	4.31	0	
ZP54K5E-PFV	208/230	1	29.3	134	0.792	0.453	014-0064-27
ZP54K5E-TF5	200/230	3	17.4	110	0.68	0	
ZP54K5E-TFD	460	3	8.6	52	3.199	0	
ZP54K5E-TFE	575	3	6.5	38.9	5.4	0	
ZP57K3E-PFJ	265	1	27.3	157	1.17	0.4	014-0064-16
ZP57K3E-PFV	208/230	1	33.6	158	0.553	0.37	014-0064-27
ZP57K3E-TF5	200/230	3	22.9	155	0.58	0	
ZP57K3E-TFD	460	3	10.7	75	2.27	0	
ZP57K3E-TFE	575	3	8.5	54	3.56	0	
ZP57KCE-PFV	208/230	1	33.6	172	0.58	0.34	014-0064-27
ZP61KCE-TF5	200/230	3	21.2	123	0.686	0	
ZP61KCE-TFD	460	3	10.9	62	2.8	0	
ZP61KCE-TFE	575	3	8.3	50	4.31	0	
ZP67KCE-TF5	200/230	3	25	149	0.562	0	
ZP67KCE-TFD	460	3	11.8	75	2.27	0	
ZP67KCE-TFE	575	3	8.6	54	3.56	0	
ZP70KWE-PFJ	265	1	34.6	170	0.667	0.362	014-0064-35
ZP70KWE-PFV	208/230	1	35.7	148	0.667	0.362	014-0064-27
ZP72KCE-TF5	200/230	3	25.9	164	0.501	0	
ZP72KCE-TF7	380	3	13.6	73	1.96	0	

‡ † See Section F Introduction for more information.

FF25

**Electrical Data - Copeland Scroll®**

Model	Volts	PH	Max RLA	LRA	Winding Resistance		Run Cap PN ‡
					Start or Line/Line †	Run	
ZP72KCE-TFD	460	3	12.5	75	2.26	0	
ZP83KCE-TF5	200/230	3	27.9	164	0.501	0	
ZP83KCE-TF7	380	3	15.5	94.3	1.64	0	
ZP83KCE-TFD	460	3	13.6	100	1.79	0	
ZP83KCE-TFE	575	3	10	78	2.76	0	
ZP83KWE-PFV	208/230	1	35.7	185	0.874	0.312	014-0064-35
ZP90KCE-TF5	200/230	3	32.9	195	0.4	0	
ZP90KCE-TF7	380	3	18.6	123	1.051	0	
ZP90KCE-TFD	460	3	16.4	95	1.59	0	
ZP90KCE-TFE	575	3	13.6	80	2.55	0	
ZPD61KCE-TF5	200/230	3	22.7	156	0.562	0	
ZPD61KCE-TF7	380	3	12.1	64	2.3	0	
ZPD61KCE-TFD	460	3	10.9	62	2.8	0	
ZPD72KCE-TF5	200/230	3	25.9	164	0.501	0	
ZPD72KCE-TF7	380	3	13.6	73	1.96	0	
ZPD72KCE-TFD	460	3	12.5	75	2.26	0	
ZPD83KCE-TF7	380	3	15.9	94.3	1.64	0	
ZPD83KCE-TFD	460	3	14.1	100	1.79	0	
ZPDT14MCE-TF7	380	3					
ZPDT14MCE-TFD	460	3					
ZPDT16MCE-TFD	460	3					
ZPDU13MCE-TFD	460	3					
ZPS20K4E-PFV	208/230	1	11.4	52	1.4	1.32	014-0064-07
ZPS26K4E-PFV	208/230	1	15.7	70	1.249	0.891	014-0064-08
ZPS30K4E-PFV	208/230	1	18.6	82	1.29	0.892	014-0064-08
ZPS30K4E-TF5	200/230	3	12.4	58	1.562	0	

‡ † See Section F Introduction for more information.

FF26

**Electrical Data - Copeland Scroll®**

Model	Volts	PH	Max RLA	LRA	Winding Resistance		Run Cap PN ‡
					Start or Line/Line †	Run	
ZPS30K4E-TFD	460	3	5	29	6.02	0	
ZPS35K4E-PFV	208/230	1	18.6	96	1.547	0.621	014-0064-25
ZPS35K4E-TF5	200/230	3	15	88	0.995	0	
ZPS35K4E-TFD	460	3	6.8	44	4.03	0	
ZPS40K4E-PFV	208/230	1	23.6	96	1.52	0.635	014-0064-25
ZPS40K4E-TF5	200/230	3	15	88	0.995	0	
ZPS40K4E-TFD	460	3	7.1	41	4.17	0	
ZPS49K4E-PFV	208/230	1	25.6	118	0.601	0.49	014-0064-27
ZPS49K4E-TF5	200/230	3	19.6	123	0.686	0	
ZPS49K4E-TFD	460	3	10.3	62	2.8	0	
ZPS51K4E-PFV	208/230	1	28.6	118	0.601	0.49	014-0064-27
ZPS51K4E-TF5	200/230	3	19.6	123	0.686	0	
ZPS51K4E-TFD	460	3	10	62	2.8	0	
ZPS51K4E-TFE	575	3	8.2	50	4.31	0	
ZPS60K4E-PFV	208/230	1	30.4	150	0.533	0.37	014-0064-27
ZPT100K3E-TF5	200/230	3					
ZPT100K3E-TF5	200/230	3					
ZPT100K3E-TFD	460	3					
ZPT100K3E-TFD	460	3					
ZPT100K3E-TFE	575	3					
ZPT100K3E-TFE	575	3					
ZPT108K3E-TF5	200/230	3					
ZPT108K3E-TF5	200/230	3					
ZPT108K3E-TFD	460	3					
ZPT108K3E-TFD	460	3					
ZPT114K3E-PFV	208/230	1					

‡ † See Section F Introduction for more information.

FF27



**Electrical Data - Copeland Scroll®**

Model	Volts	PH	Max RLA	LRA	Winding Resistance		Run Cap PN ‡
					Start or Line/Line †	Run	
ZPT114K3E-TF5 200/230		3					
ZPT114K3E-TF5 200/230		3					
ZPT114K3E-TFD 460		3					
ZPT114K3E-TFD 460		3					
ZPT122KCE-TF5 200/230		3					
ZPT122KCE-TF5 200/230		3					
ZPT122KCE-TFD 460		3					
ZPT122KCE-TFD 460		3					
ZPT134KCE-TF5 200/230		3					
ZPT134KCE-TF5 200/230		3					
ZPT134KCE-TFD 460		3					
ZPT134KCE-TFD 460		3					
ZPT144KCE-TF5 200/230		3					
ZPT144KCE-TF5 200/230		3					
ZPT144KCE-TF7 380		3					
ZPT144KCE-TF7 380		3					
ZPT144KCE-TFD 460		3					
ZPT144KCE-TFD 460		3					
ZPT166KCE-TF5 200/230		3					
ZPT166KCE-TF5 200/230		3					
ZPT166KCE-TF7 380		3					
ZPT166KCE-TF7 380		3					
ZPT166KCE-TFD 460		3					
ZPT166KCE-TFD 460		3					
ZPT166KCE-TFE 575		3					
ZPT166KCE-TFE 575		3					

‡ † See Section F Introduction for more information.

FF28

**Electrical Data - Copeland Scroll®**

Model	Volts	PH	Max RLA	LRA	Winding Resistance		Run Cap PN ‡
					Start or Line/Line †	Run	
ZPT180KCE-TF5 200/230		3					
ZPT180KCE-TF5 200/230		3					
ZPT180KCE-TFD 460		3					
ZPT180KCE-TFD 460		3					
ZPT180KCE-TFE 575		3					
ZPT180KCE-TFE 575		3					
ZPT206KCE-TF5 200/230		3					
ZPT206KCE-TF5 200/230		3					
ZPT206KCE-TFD 460		3					
ZPT206KCE-TFD 460		3					
ZPT206KCE-TFE 575		3					
ZPT206KCE-TFE 575		3					
ZPT240KCE-TF5 200/230		3					
ZPT240KCE-TF5 200/230		3					
ZPT240KCE-TFD 460		3					
ZPT240KCE-TFD 460		3					
ZPT240KCE-TFE 575		3					
ZPT240KCE-TFE 575		3					
ZPT274KCE-TF5 200/230		3					
ZPT274KCE-TF5 200/230		3					
ZPT274KCE-TFD 460		3					
ZPT274KCE-TFD 460		3					
ZPT274KCE-TFE 575		3					
ZPT274KCE-TFE 575		3					
ZPT308KCE-TFD 460		3					
ZPT308KCE-TW5200/230		3					

‡ † See Section F Introduction for more information.

FF29

**Electrical Data - Copeland Scroll®**

Model	Volts	PH	Max RLA	LRA	Winding Resistance		Run Cap PN ‡
					Start or Line/Line †	Run	
ZPT308KCE-TWD	460	3					
ZPT308KCE-TWE	575	3					
ZPT360KCE-TW7	380	3					
ZPT360KCE-TWC208/230	380	3					
ZPT360KCE-TWD	460	3					
ZPT360KCE-TWE	575	3					
ZPT364KCE-TW5200/230	380	3					
ZPT364KCE-TWD	460	3					
ZPT364KCE-TWE	575	3					
ZPT470KCE-TW7	380	3					
ZPT470KCE-TWC	230	3					
ZPT470KCE-TWD	460	3					
ZPT470KCE-TWE	575	3					
ZPT570KCE-TW5200/230	380	3					
ZPT570KCE-TW7	380	3					
ZPT570KCE-TWC208/230	380	3					
ZPT570KCE-TWD	460	3					
ZPT570KCE-TWE	575	3					
ZPT590KCE-TW7	380	3					
ZPT590KCE-TWC208/230	380	3					
ZPT590KCE-TWD	460	3					
ZPT590KCE-TWE	575	3					
ZPT770KCE-TW5200/230	380	3					
ZPT770KCE-TW5200/230	380	3					
ZPT770KCE-TW7	380	3					
ZPT770KCE-TW7	380	3					

‡ † See Section F Introduction for more information.

FF30

**Electrical Data - Copeland Scroll®**

Model	Volts	PH	Max RLA	LRA	Winding Resistance		Run Cap PN ‡
					Start or Line/Line †	Run	
ZPT770KCE-TWC208/230		3					
ZPT770KCE-TWC208/230		3					
ZPT770KCE-TWD 460		3					
ZPT770KCE-TWD 460		3					
ZPT770KCE-TWE 575		3					
ZPT770KCE-TWE 575		3					
ZPU223KCE-TFD 460		3					
ZPU240KCE-TFD 460		3					
ZPU257KCE-TFD 460		3					
ZPU272KCE-TFD 460		3					
ZPU272KCE-TXD 460		3					
ZPU272KCE-TXE 575		3					
ZPU274KCE-TFD 460		3					
ZPU274KCE-TX5 200/230		3					
ZPU274KCE-TXD 460		3					
ZPU274KCE-TXE 575		3					
ZPU285KCE-TFD 460		3					
ZPU285KCE-TX5 200/230		3					
ZPU285KCE-TXD 460		3					
ZPU285KCE-TXE 575		3					
ZPU302KCE-TFD 460		3					
ZPU302KCE-TX5 200/230		3					
ZPU302KCE-TXD 460		3					
ZPU302KCE-TXE 575		3					
ZPU319KCE-TFD 460		3					
ZPU319KCE-TX5 200/230		3					

‡ † See Section F Introduction for more information.

FF31

**Electrical Data - Copeland Scroll®**

Model	Volts	PH	Max RLA	LRA	Winding Resistance		Run Cap PN ‡
					Start or Line/Line †	Run	
ZPU319KCE-TXD	460	3					
ZPU319KCE-TXE	575	3					
ZPU336KCE-TFD	460	3					
ZPU336KCE-TW5200/230		3					
ZPU336KCE-TW7	380	3					
ZPU336KCE-TWD	460	3					
ZPU336KCE-TWE	575	3					
ZPU417KCE-TWC200/230		3					
ZPU417KCE-TWC	230	3					
ZPU417KCE-TWD	460	3					
ZPU417KCE-TWE	575	3					
ZPU520KCE-TWD	460	3					
ZPU680KCE-TW7	380	3					
ZPU680KCE-TWC208/230		3					
ZPU680KCE-TWD	460	3					
ZPU680KCE-TWE	575	3					
ZPY115MCE-TW5200/230		3					
ZPY115MCE-TW7	380	3					
ZPY115MCE-TWC208/230		3					
ZPY115MCE-TWD	460	3					
ZPY115MCE-TWE	575	3					
ZPY309KCE-TF5 200/230		3					
ZPY309KCE-TFD	460	3					
ZPY309KCE-TFE	575	3					
ZPY360KCE-TF5 200/230		3					
ZPY360KCE-TFD	460	3					

‡ † See Section F Introduction for more information.

FF32

**Electrical Data - Copeland Scroll®**

Model	Volts	PH	Max RLA	LRA	Winding Resistance		Run Cap PN ‡
					Start or Line/Line †	Run	
ZPY360KCE-TFE	575	3					
ZPY411KCE-TF5	200/230	3					
ZPY411KCE-TFD	460	3					
ZPY411KCE-TFE	575	3					
ZPY462KCE-TFD	460	3					
ZPY462KCE-TW5200/230		3					
ZPY462KCE-TW7	380	3					
ZPY462KCE-TWD	460	3					
ZPY462KCE-TWE	575	3					
ZPY546KCE-TFD	460	3					
ZPY546KCE-TW5200/230		3					
ZPY546KCE-TW7	380	3					
ZPY546KCE-TWD	460	3					
ZPY546KCE-TWE	575	3					
ZPY705KCE-TW7	380	3					
ZPY705KCE-TWC	230	3					
ZPY705KCE-TWD	460	3					
ZPY705KCE-TWE	575	3					
ZPY855KCE-TW5200/230		3					
ZPY855KCE-TW7	380	3					
ZPY855KCE-TWC208/230		3					
ZPY855KCE-TWD	460	3					
ZPY855KCE-TWE	575	3					
ZR108KC-TF5	200/230	3	33.6	225	0.347	0	
ZR108KC-TF7	380	3	18.6	140	0.93	0	
ZR108KC-TFD	460	3	17.3	114	1.36	0	

‡ † See Section F Introduction for more information.

FF33

**Electrical Data - Copeland Scroll®**

Model	Volts	PH	Max RLA	LRA	Winding Resistance		Run Cap PN ‡
					Start or Line/Line †	Run	
ZR108KC-TFE	575	3	13.5	80	2.55	0	
ZR108KCE-TF5	200/230	3	33.6	225	0.347	0	
ZR108KCE-TF7	380	3	18.6	140	0.93	0	
ZR108KCE-TFD	460	3	17.3	114	1.36	0	
ZR108KCE-TFE	575	3	13.5	80	2.55	0	
ZR11M3-TW7	380	3	20.7	144	0.78	0	
ZR11M3-TWC	208/230	3	33.3	232	0.29	0	
ZR11M3-TWD	460	3	17	125	1.11	0	
ZR11M3-TWE	575	3	12.9	100	1.86	0	
ZR11M3E-TW7	380	3	24.9	144	0.78	0	
ZR11M3E-TWC	208/230	3	38.2	232	0.29	0	
ZR11M3E-TWD	460	3	18.6	125	1.11	0	
ZR11M3E-TWE	575	3	15.4	100	1.86	0	
ZR125KC-TF5	200/230	3	41.4	239	0.306	0	
ZR125KC-TF7	380	3	23.6	145	0.85	0	
ZR125KC-TFD	460	3	19.2	125	1.227	0	
ZR125KC-TFE	575	3	13.8	80	2.55	0	
ZR125KCE-TF5	200/230	3	41.4	239	0.306	0	
ZR125KCE-TF7	380	3	23.6	145	0.85	0	
ZR125KCE-TFD	460	3	20	125	1.227	0	
ZR125KCE-TFE	575	3	13.8	80	2.55	0	
ZR12M3-TW5	200/230	3	37.4	278	0.26	0	
ZR12M3-TW7	380	3	25.4	151	0.72	0	
ZR12M3-TWC	208/230	3	37.4	278	0.26	0	
ZR12M3-TWD	460	3	18.4	127	1.02	0	
ZR12M3-TWE	575	3	15.2	100	1.7	0	

‡ † See Section F Introduction for more information.

FF34

**Electrical Data - Copeland Scroll®**

Model	Volts	PH	Max RLA	LRA	Winding Resistance		Run Cap PN ‡
					Start or Line/Line †	Run	
ZR12M3E-TW5	200/230	3	41.1	278	0.26	0	
ZR12M3E-TW7	380	3	30.3	151	0.72	0	
ZR12M3E-TWC	208/230	3	41.1	278	0.26	0	
ZR12M3E-TWD	460	3	22.1	127	1.02	0	
ZR12M3E-TWE	575	3	18.3	100	1.7	0	
ZR144KC-TF5	200/230	3	47.1	245	0.282	0	
ZR144KC-TF7	380	3	24.4	145	0.85	0	
ZR144KC-TFD	460	3	19.6	125	1.227	0	
ZR144KC-TFE	575	3	15.9	100	1.87	0	
ZR144KCE-TF5	200/230	3	47.1	245	0.282	0	
ZR144KCE-TF7	380	3	24.6	145	0.85	0	
ZR144KCE-TFD	460	3	20.7	125	1.227	0	
ZR144KCE-TFE	575	3	15.9	100	1.87	0	
ZR160KC-TF7	380	3	27.1	138	0.845	0	
ZR160KC-TFD	460	3	25	150	1.1	0	
ZR160KC-TW5	200/230	3	53.6	300	0.227	0	
ZR160KC-TW7	380	3	28.6	139	0.853	0	
ZR160KC-TWD	460	3	24.3	150	1.108	0	
ZR160KC-TWE	575	3	20.7	109	1.518	0	
ZR160KCE-TF7	380	3	27.1	138	0.845	0	
ZR160KCE-TFD	460	3	25	150	1.1	0	
ZR160KCE-TW5	200/230	3	55	300	0.227	0	
ZR160KCE-TW7	380	3	30.7	139	0.853	0	
ZR160KCE-TWD	460	3	25.7	150	1.108	0	
ZR160KCE-TWE	575	3	21.4	109	1.518	0	
ZR16K4-PFJ	265	1	8.6	38	3.4	2.16	014-0064-07

‡ † See Section F Introduction for more information.

FF35



**Electrical Data - Copeland Scroll®**

Model	Volts	PH	Max RLA	LRA	Winding Resistance		Run Cap PN ‡
					Start or Line/Line †	Run	
ZR16K4-PFV	208/230	1	10	41	2.73	1.77	014-0064-06
ZR16K4E-PFJ	265	1	8.6	38	3.4	2.16	014-0064-07
ZR16K4E-PFV	208/230	1	10	41	2.73	1.77	014-0064-06
ZR16KA-PFV	208/230	1	8.6	40.3	2.61	1.74	014-0064-06
ZR16M3-TW5	200/230	3	45.7	350	0.22	0	
ZR16M3-TW7	380	3	27.9	195	0.57	0	
ZR16M3-TWC	208/230	3	45.7	350	0.22	0	
ZR16M3-TWD	460	3	24.3	158	0.83	0	
ZR16M3-TWE	575	3	19.3	125	1.28	0	
ZR16M3E-TW5	200/230	3	48.9	350	0.22	0	
ZR16M3E-TW7	380	3	30	195	0.57	0	
ZR16M3E-TWC	208/230	3	48.9	350	0.22	0	
ZR16M3E-TWD	460	3	27.2	158	0.83	0	
ZR16M3E-TWE	575	3	19.3	125	1.28	0	
ZR18K3-PFV	208/230	1	9.3	47	2.67	1.43	014-0064-06
ZR18K3E-PFV	208/230	1	9.3	47	2.67	1.43	014-0064-06
ZR18K4-PFJ	265	1	8.6	39	3.24	1.81	014-0064-13
ZR18K4-PFV	208/230	1	10.7	45	2.27	1.81	014-0064-07
ZR18K4E-PFJ	265	1	8.6	39	3.24	1.81	014-0064-13
ZR18K4E-PFV	208/230	1	10.7	45	2.27	1.81	014-0064-07
ZR18KC-PFV	208/230	1	10.7	47	3.48	1.56	014-0064-06
ZR190KC-TFD	460	3	27.9	179	0.833	0	
ZR190KC-TW5	200/230	3	58.6	340	0.226	0	
ZR190KC-TW7	380	3	35.7	196	0.56	0	
ZR190KC-TWD	460	3	28.6	173	0.833	0	
ZR190KC-TWE	575	3	23.6	132	1.268	0	

‡ † See Section F Introduction for more information.

FF36

**Electrical Data - Copeland Scroll®**

Model	Volts	PH	Max RLA	LRA	Winding Resistance		Run Cap PN ‡
					Start or Line/Line †	Run	
ZR190KCE-TFD	460	3	27.9	179	0.833	0	
ZR190KCE-TW5	200/230	3	60	340	0.226	0	
ZR190KCE-TW7	380	3	37.1	196	0.56	0	
ZR190KCE-TWD	460	3	31.4	173	0.833	0	
ZR190KCE-TWE	575	3	25	132	1.268	0	
ZR19M3-TW5	200/230	3	53.6	425	0.19	0	
ZR19M3-TW7	380	3	36.4	239	0.52	0	
ZR19M3-TWC	208/230	3	53.6	425	0.19	0	
ZR19M3-TWD	460	3	26.4	187	0.72	0	
ZR19M3-TWE	575	3	23.6	148	1.1	0	
ZR19M3E-TW5	200/230	3	55	425	0.19	0	
ZR19M3E-TW7	380	3	37.1	239	0.52	0	
ZR19M3E-TWC	208/230	3	55	425	0.19	0	
ZR19M3E-TWD	460	3	32.1	187	0.72	0	
ZR19M3E-TWE	575	3	25.7	148	1.1	0	
ZR21KA-PFV	208/230	1	11.6	54	2.14	1.27	014-0064-07
ZR22K3-PFJ	265	1	9.6	47	2.85	1.62	014-0064-14
ZR22K3-PFV	208/230	1	11.4	56	2.06	1.18	014-0064-25
ZR22K3-TF5	200/230	3	7.9	45	2.15	0	
ZR22K3-TFD	460	3	3.9	22.4	8.64	0	
ZR22K3E-PFJ	265	1	9.6	47	2.85	1.62	014-0064-14
ZR22K3E-PFV	208/230	1	11.4	56	2.06	1.18	014-0064-25
ZR22K3E-TF5	200/230	3	7.9	45	2.15	0	
ZR22K3E-TFD	460	3	3.9	22.4	8.64	0	
ZR22K4-PFJ	265	1	10	55	2.75	1.81	014-0064-25
ZR22K4-PFV	208/230	1	12.1	54	2.67	1.31	014-0064-07

‡ † See Section F Introduction for more information.

FF37

**Electrical Data - Copeland Scroll®**

Model	Volts	PH	Max RLA	LRA	Winding Resistance		Run Cap PN ‡
					Start or Line/Line †	Run	
ZR22K4E-PFJ	265	1	10	55	2.75	1.81	014-0064-25
ZR22K4E-PFV	208/230	1	12.1	54	2.67	1.31	014-0064-07
ZR24K3-PFJ	265	1	11.4	58	3.34	1.26	014-0064-14
ZR24K3-PFV	208/230	1	13.6	61	2.28	1.01	014-0064-08
ZR24K3-TF5	200/230	3	8.6	55	1.79	0	
ZR24K3-TFD	460	3	4.3	27	7.1	0	
ZR24K3E-PFJ	265	1	11.4	58	3.34	1.26	014-0064-14
ZR24K3E-PFV	208/230	1	13.6	61	2.28	1.01	014-0064-08
ZR24K3E-TF5	200/230	3	8.6	55	1.79	0	
ZR24K3E-TFD	460	3	4.3	27	7.1	0	
ZR24K4-PFJ	265	1	10.4	52	2.86	1.5	014-0064-25
ZR24K4-PFV	208/230	1	13.6	63	2.45	1.17	014-0064-07
ZR24K4E-PFJ	265	1	10.4	52	2.86	1.5	014-0064-25
ZR24K4E-PFV	208/230	1	13.6	63	2.45	1.17	014-0064-07
ZR24KL-PFV	208/230	1	13.6	61	2.28	1.01	014-0064-08
ZR250KC-TW5	200/230	3	81.4	505	0.14	0	
ZR250KC-TW7	380	3	42.1	280	0.44	0	
ZR250KC-TWC	208/230	3	81.4	505	0.14	0	
ZR250KC-TWD	460	3	33.6	225	0.63	0	
ZR250KC-TWE	575	3	27.1	180	0.97	0	
ZR250KCE-TW5	200/230	3	81.4	505	0.14	0	
ZR250KCE-TW7	380	3	42.1	280	0.44	0	
ZR250KCE-TWC	208/230	3	81.4	505	0.14	0	
ZR250KCE-TWD	460	3	37.9	225	0.63	0	
ZR250KCE-TWE	575	3	32.1	180	0.97	0	
ZR26K3-PFJ	265	1	12.1	58	2.94	1.23	014-0064-14

‡ † See Section F Introduction for more information.

FF38

**Electrical Data - Copeland Scroll®**

Model	Volts	PH	Max RLA	LRA	Winding Resistance		Run Cap PN ‡
					Start or Line/Line †	Run	
ZR26K3-PFV	208/230	1	13.6	67	1.96	0.94	014-0064-08
ZR26K3-TF5	200/230	3	8.6	55	1.79	0	
ZR26K3-TFD	460	3	4.3	27	7.1	0	
ZR26K3E-PFJ	265	1	12.1	58	2.94	1.23	014-0064-14
ZR26K3E-PFV	208/230	1	13.6	67	1.96	0.94	014-0064-08
ZR26K3E-TF5	200/230	3	8.6	55	1.79	0	
ZR26KA-PFV	208/230	1	15.7	68	1.34	0.92	014-0064-25
ZR26KA-TF5	200/230	3	8.6	58			
ZR26KC-PFV	208/230	1	15	73	3.16	0.99	014-0064-12
ZR26KL-PFV	208/230	1	13.6	67	1.96	0.94	014-0064-08
ZR28K3-PFJ	265	1	12.9	61	2.23	1.2	014-0064-15
ZR28K3-PFV	208/230	1	15	72.5	1.72	0.905	014-0064-25
ZR28K3-TF5	200/230	3	10	63	1.46	0	
ZR28K3-TFD	460	3	5	31	5.94	0	
ZR28K3E-PFJ	265	1	12.9	61	2.23	1.2	014-0064-15
ZR28K3E-PFV	208/230	1	15	72.5	1.72	0.905	014-0064-25
ZR28K3E-TF5	200/230	3	10	63	1.46	0	
ZR28K3E-TFD	460	3	5	31	5.94	0	
ZR28KA-PFV	208/230	1	15.7	68	1.34	0.92	014-0064-25
ZR28KC-PFV	208/230	1	15.7	73	2.71	0.908	014-0064-13
ZR300KC-TW5	208/230	3	87.9	500	0.112	0	
ZR300KC-TW7	380	3	54.3	305	0.311	0	
ZR300KC-TWC	208/230	3	87.9	500	0.112	0	
ZR300KC-TWD	460	3	42.9	250	0.45	0	
ZR300KC-TWE	575	3	34.3	198	0.701	0	
ZR300KCE-TW5	208/230	3	81.4	500	0.112	0	

‡ † See Section F Introduction for more information.

FF39

**Electrical Data - Copeland Scroll®**

Model	Volts	PH	Max RLA	LRA	Winding Resistance		Run Cap PN ‡
					Start or Line/Line †	Run	
ZR300KCE-TW7	380	3	61.4	305	0.311	0	
ZR300KCE-TWC	208/230	3	81.4	500	0.112	0	
ZR300KCE-TWD	460	3	48.6	250	0.45	0	
ZR300KCE-TWE	575	3	36.4	198	0.701	0	
ZR30K3-PFJ	265	1	14.3	76	1.89	0.981	014-0064-15
ZR30K3-PFV	208/230	1	15	73	1.72	0.833	014-0064-25
ZR30K3-TF5	200/230	3	10.7	63	1.46	0	
ZR30K3-TFD	460	3	5	31	5.94	0	
ZR30K3-TFE	575	3	4.3	24	9.2	0	
ZR30K3E-PFJ	265	1	14.3	76	1.89	0.981	014-0064-15
ZR30K3E-PFV	208/230	1	15	73	1.72	0.833	014-0064-25
ZR30K3E-TF5	200/230	3	10.7	63	1.46	0	
ZR30K3E-TFD	460	3	5	31	5.94	0	
ZR30K3E-TFE	575	3	4.3	24	9.2	0	
ZR30KC-PFV	208/230	1	16.4	84	2.51	0.787	014-0064-07
ZR30KS-TFD	460	3	5.7	44.4			
ZR310KC-TW7	380	3	55.7	353	0.36	0	
ZR310KC-TWC	208/230	3	93.6	605	0.12	0	
ZR310KC-TWD	460	3	41.4	272	0.51	0	
ZR310KCE-TW7	380	3	55.7	353	0.36	0	
ZR310KCE-TWC	208/230	3	87.1	605	0.12	0	
ZR310KCE-TWD	460	3	43.6	272	0.51	0	
ZR32K3-PFJ	265	1	14.3	76	1.89	0.981	014-0064-15
ZR32K3-PFV	208/230	1	16.4	83	1.69	0.722	014-0064-25
ZR32K3-TF5	200/230	3	10.7	77	1.38	0	
ZR32K3-TFD	460	3	5.4	35	5.35	0	

‡ † See Section F Introduction for more information.

FF40

**Electrical Data - Copeland Scroll®**

Model	Volts	PH	Max RLA	LRA	Winding Resistance		Run Cap PN ‡
					Start or Line/Line †	Run	
ZR32K3-TFE	575	3	3.9	28	8.38	0	
ZR32K3E-PFJ	265	1	14.3	76	1.89	0.981	014-0064-15
ZR32K3E-PFV	208/230	1	16.4	83	1.69	0.722	014-0064-25
ZR32K3E-TF5	200/230	3	10.7	77	1.38	0	
ZR32K3E-TFD	460	3	5.4	35	5.35	0	
ZR32K3E-TFE	575	3	3.9	28	8.38	0	
ZR32KA-PFV	208/230	1	16.1	77	1.07	0.839	014-0064-29
ZR32KA-TF5	200/230	3	10.7	73			
ZR32KA-TFD	460	3	6.4	38			
ZR32KA-TFE	575	3	4.5	28			
ZR32KS-TFD	460	3	5.7	44.4			
ZR34K3-PFJ	265	1	14.3	75	2.07	0.937	014-0064-16
ZR34K3-PFV	208/230	1	17.9	88	1.46	0.691	014-0064-29
ZR34K3-TF5	200/230	3	11.4	77	1.234	0	
ZR34K3-TF7	380	3	6.8	39	4.83	0	
ZR34K3-TFD	460	3	5.7	39	4.83	0	
ZR34K3-TFE	575	3	4.7	31	7.89	0	
ZR34K3E-PFJ	265	1	14.3	75	2.07	0.937	014-0064-16
ZR34K3E-PFV	208/230	1	17.9	88	1.46	0.691	014-0064-29
ZR34K3E-TF5	200/230	3	11.4	77	1.234	0	
ZR34K3E-TF7	380	3	6.8	39	4.83	0	
ZR34K3E-TFD	460	3	5.7	39	4.83	0	
ZR34K3E-TFE	575	3	4.7	31	7.89	0	
ZR34KA-PFV	208/230	1	16.4	77	1.07	0.839	014-0064-26
ZR34KA-TF5	200/230	3	12.1	73			
ZR34KA-TFD	460	3	6.4	38			

‡ † See Section F Introduction for more information.

FF41

**Electrical Data - Copeland Scroll®**

Model	Volts	PH	Max RLA	LRA	Winding Resistance		Run Cap PN ‡
					Start or Line/Line †	Run	
ZR34KA-TFE	575	3	3.9	36.5			
ZR34KC-PFV	208/230	1	15.7	93	1.9	0.74	014-0064-08
ZR34KH-PFJ	265	1	17.1	102	1.81	0.753	014-0064-17
ZR34KH-TFD	460	3	7.1	39	4.83	0	
ZR34KL-PFV	208/230	1	17.9	88	1.46	0.691	014-0064-29
ZR34KL-TF5	200/230	3	11.4	77	1.234	0	
ZR36K3-PFJ	265	1	16.4	83	1.84	0.887	014-0064-16
ZR36K3-PFV	208/230	1	18.4	95	1.39	0.65	014-0064-29
ZR36K3-TF5	200/230	3	11.4	77	1.234	0	
ZR36K3-TFD	460	3	5.7	39	4.83	0	
ZR36K3-TFE	575	3	4.7	31	7.89	0	
ZR36K3E-PFJ	265	1	16.4	83	1.84	0.887	014-0064-16
ZR36K3E-PFV	208/230	1	18.4	95	1.39	0.65	014-0064-29
ZR36K3E-TF5	200/230	3	11.4	77	1.234	0	
ZR36K3E-TFD	460	3	5.7	39	4.83	0	
ZR36K3E-TFE	575	3	4.7	31	7.89	0	
ZR36KC-PFV	208/230	1	17.9	100	2.82	0.64	014-0064-14
ZR36KH-PFJ	265	1	17.1	96	1.81	0.753	014-0064-17
ZR36KH-TFD	460	3	6.4	39	4.83	0	
ZR380KC-TW5	200/230	3	111.4	599	0.096	0	
ZR380KC-TW7	380	3	63.6	358	0.244	0	
ZR380KC-TWC	208/230	3	111.4	599	0.096	0	
ZR380KC-TWD	460	3	54.3	310	0.349	0	
ZR380KC-TWE	575	3	43.6	239	0.555	0	
ZR380KCE-TW5	200/230	3	121.4	599	0.096	0	
ZR380KCE-TW7	380	3	68.6	358	0.244	0	

‡ † See Section F Introduction for more information.

FF42

**Electrical Data - Copeland Scroll®**

Model	Volts	PH	Max RLA	LRA	Winding Resistance		Run Cap PN ‡
					Start or Line/Line †	Run	
ZR380KCE-TWC	208/230	3	121.4	599	0.096	0	
ZR380KCE-TWD	460	3	59.3	310	0.349	0	
ZR380KCE-TWE	575	3	47.1	239	0.555	0	
ZR38KA-PFV	208/230	1	21.4	104	1.38	0.57	014-0064-28
ZR38KA-TF5	200/230	3	13.6	88	0.995	0	
ZR38KA-TFD	460	3	6.4	44	4.03	0	
ZR38KA-TFE	575	3	4.6	33	6.32	0	
ZR39KH-PFJ	265	1	22.9	113	1.67	0.586	014-0064-18
ZR39KH-TFD	460	3	7.9	44	4.03	0	
ZR40K3-PFJ	265	1	17.1	96	1.81	0.753	014-0064-17
ZR40K3-PFV	208/230	1	20	104	1.38	0.57	014-0064-28
ZR40K3-TF5	200/230	3	13.9	88	0.995	0	
ZR40K3-TFD	460	3	6.4	44	4.03	0	
ZR40K3-TFE	575	3	5.4	34	6.28	0	
ZR40K3E-PFJ	265	1	17.1	96	1.81	0.753	014-0064-17
ZR40K3E-PFV	208/230	1	20	104	1.38	0.57	014-0064-28
ZR40K3E-TF5	200/230	3	13.9	88	0.995	0	
ZR40K3E-TFD	460	3	6.4	44	4.03	0	
ZR40K3E-TFE	575	3	5.4	34	6.28	0	
ZR40KC-PFV	208/230	1	20	103	2.94	0.598	014-0064-14
ZR42K3-PFJ	265	1	17.1	98	1.65	0.691	014-0064-18
ZR42K3-PFV	208/230	1	20.4	109	1.28	0.54	014-0064-26
ZR42K3-TF5	200/230	3	13.9	88	0.995	0	
ZR42K3-TFD	460	3	7.1	44	4.03	0	
ZR42K3-TFE	575	3	5.4	34	6.28	0	
ZR42K3E-PFJ	265	1	17.1	98	1.65	0.691	014-0064-18

‡ † See Section F Introduction for more information.

FF43



**Electrical Data - Copeland Scroll®**

Model	Volts	PH	Max RLA	LRA	Winding Resistance		Run Cap PN ‡
					Start or Line/Line †	Run	
ZR42K3E-PFV	208/230	1	20.4	109	1.28	0.54	014-0064-26
ZR42K3E-TF5	200/230	3	13.9	88	0.995	0	
ZR42K3E-TFD	460	3	7.1	44	4.03	0	
ZR42K3E-TFE	575	3	5.4	34	6.28	0	
ZR42KA-PFV	208/230	1	21.4	97	1.374	0.595	014-0064-28
ZR42KA-TF5	200/230	3	13.6	88	0.995	0	
ZR42KA-TFD	460	3	6.4	44	4.03	0	
ZR42KA-TFE	575	3	5.1	37	6.21	0	
ZR42KC-PFV	208/230	1	20.7	127	2.15	0.506	014-0064-14
ZR44KA-PFV	208/230	1	22.5	137	1.34	0.46	014-0064-26
ZR44KA-TF5	200/230	3	13.6	83.1	1.034	0	
ZR44KA-TFD	460	3	6.8	41	4.17	0	
ZR44KA-TFE	575	3	4.6	33	6.32	0	
ZR45K3-PFJ	265	1	19.3	113	1.67	0.586	014-0064-18
ZR45K3-PFV	208/230	1	23.6	137	1.34	0.46	014-0064-18
ZR45K3-TF5	200/230	3	15.4	91	0.994	0	
ZR45K3-TFD	460	3	7.9	46	3.88	0	
ZR45K3E-PFJ	265	1	19.3	113	1.67	0.586	014-0064-18
ZR45K3E-PFV	208/230	1	23.6	137	1.34	0.46	014-0064-18
ZR45KC-PFV	208/230	1	24.3	131	1.85	0.475	014-0064-08
ZR45KC-TF5	200/230	3	14.3	91	0.994	0	
ZR45KC-TFD	460	3	7.1	46	3.88	0	
ZR45KC-TFE	575	3	5.7	37	6.21	0	
ZR45KCE-TFD	460	3	7.1	46	3.88	0	
ZR46K3-PFV	208/230	1	26.4	129	0.765	0.475	014-0064-26
ZR46K3-TF5	200/230	3	15	120	0.797	0	

‡ † See Section F Introduction for more information.

FF44

**Electrical Data - Copeland Scroll®**

Model	Volts	PH	Max RLA	LRA	Winding Resistance		Run Cap PN ‡
					Start or Line/Line †	Run	
ZR46K3-TFD	460	3	8.2	49.5	3.64	0	
ZR46K3-TFE	575	3	6.4	40	5.72	0	
ZR46KC-TF5	200/230	3	15	108	0.803	0	
ZR46KC-TF7	380	3	8	57	2.77	0	
ZR46KC-TFD	460	3	7.4	47.5	3.58	0	
ZR46KCE-TF5	200/230	3	16.1	115	0.808	0	
ZR47K3-PFJ	265	1	19.3	113	1.67	0.586	014-0064-18
ZR47K3-PFV	208/230	1	21.4	137	1.34	0.46	014-0064-18
ZR47K3-TF5	200/230	3	16.4	91	0.994	0	
ZR47K3-TFD	460	3	7.9	50	3.88	0	
ZR47K3-TFE	575	3	5.7	37	6.21	0	
ZR47K3E-PFJ	265	1	19.3	113	1.67	0.586	014-0064-18
ZR47K3E-PFV	208/230	1	21.4	137	1.34	0.46	014-0064-18
ZR47K3E-TF5	200/230	3	16.4	91	0.994	0	
ZR47K3E-TFD	460	3	7.9	50	3.88	0	
ZR47K3E-TFE	575	3	5.7	37	6.21	0	
ZR47KC-PFV	208/230	1	24.3	131	1.85	0.475	014-0064-25
ZR47KC-TF5	200/230	3	14.3	91	0.994	0	
ZR47KC-TF7	380	3	9.3	54	2.76	0	
ZR47KC-TFD	380/460	3	7.1	46	3.88	0	
ZR47KC-TFE	575	3	5.7	37	6.21	0	
ZR47KCE-TF5	200/230	3	14.3	91	0.994	0	
ZR47KCE-TF7	380	3	9.3	54	2.76	0	
ZR47KCE-TFD	380/460	3	7.1	46	3.88	0	
ZR47KCE-TFE	575	3	5.7	37	6.21	0	
ZR48K3-PFJ	265	1	19.3	113	1.67	0.586	014-0064-18

‡ † See Section F Introduction for more information.

FF45

**Electrical Data - Copeland Scroll®**

Model	Volts	PH	Max RLA	LRA	Winding Resistance		Run Cap PN ‡
					Start or Line/Line †	Run	
ZR48K3-PFV	208/230	1	22.1	137	1.34	0.46	014-0064-18
ZR48K3-TF5	200/230	3	16.4	91	0.994	0	
ZR48K3-TFD	460	3	7.9	50	3.88	0	
ZR48K3-TFE	575	3	5.7	37	6.21	0	
ZR48K3E-PFJ	265	1	19.3	113	1.67	0.586	014-0064-18
ZR48K3E-PFV	208/230	1	22.1	137	1.34	0.46	014-0064-18
ZR48K3E-TF5	200/230	3	16.4	91	0.994	0	
ZR48K3E-TFD	460	3	7.9	50	3.88	0	
ZR48K3E-TFE	575	3	5.7	37	6.21	0	
ZR48KC-PFV	208/230	1	23.6	132	2.75	0.437	014-0064-14
ZR48KC-TF5	200/230	3	16.4	91	0.994	0	
ZR48KC-TF7	380	3	9.3	54	2.76	0	
ZR48KC-TFD	460	3	7.9	50	3.88	0	
ZR48KC-TFE	575	3	6.4	37	6.21	0	
ZR48KCE-PFV	208/230	1	23.6	132	2.75	0.437	014-0064-14
ZR48KCE-TF5	200/230	3	16.4	91	0.994	0	
ZR48KCE-TF7	380	3	9.3	54	2.76	0	
ZR48KCE-TFD	460	3	7.9	50	3.88	0	
ZR48KCE-TFE	575	3	6.4	37	6.21	0	
ZR49K3-PFV	208/230	1	26.4	129	0.779	0.432	014-0064-26
ZR49K3-TF5	200/230	3	15	120	0.797	0	
ZR49K3-TFD	460	3	8.2	49.5	3.64	0	
ZR49K3-TFE	575	3	6.4	40	5.72	0	
ZR49K3E-TFD	460	3	8.2	49.5	3.64	0	
ZR49KC-PFV	208/230	1	25	132	2.089	0.454	014-0064-15
ZR49KC-TF5	200/230	3	15	115	0.808	0	

‡ † See Section F Introduction for more information.

FF46

**Electrical Data - Copeland Scroll®**

Model	Volts	PH	Max RLA	LRA	Winding Resistance		Run Cap PN ‡
					Start or Line/Line †	Run	
ZR49KC-TF7	380	3	8.8	57	2.77	0	
ZR49KC-TFD	460	3	7.4	47.5	3.58	0	
ZR49KC-TFE	575	3	5.9	37.5	6.26	0	
ZR49KCE-PFV	208/230	1	25	132	2.089	0.454	014-0064-15
ZR49KCE-TF5	200/230	3	15	115	0.808	0	
ZR49KCE-TF7	380	3	8.8	57	2.77	0	
ZR49KCE-TFD	460	3	7.4	47.5	3.58	0	
ZR49KCE-TFE	575	3	5.9	37.5	6.26	0	
ZR52K3-PFV	208/230	1	27.9	148	0.572	0.406	014-0064-27
ZR52K3-TF5	200/230	3	17.1	128	0.686	0	
ZR52K3-TFD	460	3	7.5	49.5	3.64	0	
ZR52K3-TFE	575	3	5.7	40	5.72	0	
ZR54K3-PFV	208/230	1	27.9	148	0.572	0.406	014-0064-27
ZR54K3-TF5	200/230	3	19.3	123	0.686	0	
ZR54K3-TFD	460	3	7.5	49.5	3.64	0	
ZR54K3-TFE	575	3	6.4	40	5.72	0	
ZR54K3E-TF5	200/230	3	19.3	123	0.686	0	
ZR54K3E-TFD	460	3	7.5	49.5	3.64	0	
ZR54K3E-TFE	575	3	6.4	40	5.72	0	
ZR54KA-PFV	208/230	1	28.2	141	0.768	0.461	014-0064-27
ZR54KA-TF5	200/230	3	17.1	110	0.68	0	
ZR54KA-TFD	460	3	7.9	52	3.199	0	
ZR54KA-TFE	575	3	5.9	38.9	5.4	0	
ZR54KC-PFV	208/230	1	28.6	150	1.12	0.386	014-0064-26
ZR54KC-TF5	200/230	3	16.4	124	0.735	0	
ZR54KC-TF7	380	3	9.3	65.8	2.46	0	

‡ † See Section F Introduction for more information.

FF47

**Electrical Data - Copeland Scroll®**

Model	Volts	PH	Max RLA	LRA	Winding Resistance		Run Cap PN ‡
					Start or Line/Line †	Run	
ZR54KC-TFD	460	3	8.3	59.6	2.9	0	
ZR54KC-TFE	575	3	6.6	49.4	4.74	0	
ZR54KCE-TF5	200/230	3	16.4	124	0.735	0	
ZR54KCE-TF7	380	3	9.3	65.8	2.46	0	
ZR54KCE-TFD	460	3	8.3	59.6	2.9	0	
ZR54KCE-TFE	575	3	6.6	49.4	4.74	0	
ZR54KS-TF5	200/230	3	18.3	125	0.69	0	
ZR54KS-TF7	380	3	9.9	65	2.13	0	
ZR54KS-TFD	460	3	10	59	2.78	0	
ZR54KSE-TF5	200/230	3	18.3	125	0.69	0	
ZR54KSE-TFD	460	3	10	59	2.78	0	
ZR57K3-PFV	208/230	1	32.1	148	0.667	0.362	014-0064-27
ZR57K3-TF5	200/230	3	19.3	123	0.686	0	
ZR57K3-TFD	460	3	9.1	62	2.75	0	
ZR57K3-TFE	575	3	7.9	50	4.31	0	
ZR57K3E-TF5	200/230	3	19.3	123	0.686	0	
ZR57K3E-TFD	460	3	9.1	62	2.75	0	
ZR57K3E-TFE	575	3	7.9	50	4.31	0	
ZR57KC-PFV	208/230	1	27.9	150	1.12	0.386	014-0064-26
ZR57KC-TF5	200/230	3	17.2	124	0.735	0	
ZR57KC-TF7	380	3	10.7	75	1.98	0	
ZR57KC-TFD	380/460	3	8.3	59.6	2.9	0	
ZR57KC-TFE	575	3	6.6	49.4	4.74	0	
ZR57KCE-TF5	200/230	3	17.2	124	0.735	0	
ZR57KCE-TFD	380/460	3	8.3	59.6	2.9	0	
ZR57KCE-TFE	575	3	6.6	49.4	4.74	0	

‡ † See Section F Introduction for more information.

FF48

**Electrical Data - Copeland Scroll®**

Model	Volts	PH	Max RLA	LRA	Winding Resistance		Run Cap PN ‡
					Start or Line/Line †	Run	
ZR57KH-TFD	460	3	10	62	2.75	0	
ZR57KS-TF5	200/230	3	18	125	0.69	0	
ZR57KS-TF7	380	3	10.9	65	2.13	0	
ZR57KS-TFD	460	3	NA	59	2.78	0	
ZR57KSE-TF5	200/230	3	18	125	0.69	0	
ZR57KSE-TFD	460	3	NA	59	2.78	0	
ZR61K3-PFV	208/230	1	32.1	148	0.654	0.355	014-0064-27
ZR61K3-TF5	200/230	3	19.3	137	0.612	0	
ZR61K3-TFD	460	3	9.1	62	2.75	0	
ZR61K3-TFE	575	3	7.9	50	4.31	0	
ZR61K3E-PFV	208/230	1	32.1	148	0.654	0.355	014-0064-27
ZR61K3E-TF5	200/230	3	19.3	137	0.612	0	
ZR61K3E-TFD	460	3	9.1	62	2.75	0	
ZR61K3E-TFE	575	3	7.9	50	4.31	0	
ZR61KC-PFV	208/230	1	30.1	144	1.328	0.383	014-0064-34
ZR61KC-TF5	200/230	3	20.7	128	0.726	0	
ZR61KC-TF7	380	3	10.7	64	2.3	0	
ZR61KC-TFD	460	3	10	63	2.72	0	
ZR61KC-TFE	575	3	7.4	49	4.44	0	
ZR61KCE-PFV	208/230	1	26.4	144	1.328	0.383	014-0064-34
ZR61KCE-TF5	200/230	3	20.7	128	0.726	0	
ZR61KCE-TF7	380	3	10.7	64	2.3	0	
ZR61KCE-TFD	460	3	10	63	2.72	0	
ZR61KCE-TFE	575	3	7.4	49	4.44	0	
ZR61KH-TFD	460	3	11.4	68	2.673	0	
ZR61KS-TF5	200/230	3	22.9	125	0.69	0	

‡ † See Section F Introduction for more information.

FF49

**Electrical Data - Copeland Scroll®**

Model	Volts	PH	Max RLA	LRA	Winding Resistance		Run Cap PN ‡
					Start or Line/Line †	Run	
ZR61KS-TF7	380	3	11.8	65	2.13	0	
ZR61KS-TFD	460	3	10	56	2.78	0	
ZR61KSE-TFD	460	3	10	56	2.78	0	
ZR67KW-PFV	208/230	1	27.9	129	0.779	0.432	014-0064-26
ZR68KC-PFJ	265	1	30.7	160	1.921	0.415	014-0064-16
ZR68KC-PFV	208/230	1	32.1	176	1.408	0.346	014-0064-35
ZR68KC-TF5	200/230	3	20.7	156	0.562	0	
ZR68KC-TF7	380	3	10.7	70	1.92	0	
ZR68KC-TFD	460	3	10	75	2.27	0	
ZR68KC-TFE	575	3	8.2	54	3.56	0	
ZR68KCE-PFJ	265	1	30.7	160	1.921	0.415	014-0064-16
ZR68KCE-PFV	208/230	1	32.1	176	1.408	0.346	014-0064-35
ZR68KCE-TF5	200/230	3	20.7	156	0.562	0	
ZR68KCE-TF7	380	3	10.7	70	1.92	0	
ZR68KCE-TFD	460	3	10	75	2.27	0	
ZR68KCE-TFE	575	3	8.2	54	3.56	0	
ZR72KC-TF5	200/230	3	20.7	156	0.562	0	
ZR72KC-TF7	380	3	10.7	70	1.92	0	
ZR72KC-TFD	460	3	10	75	2.27	0	
ZR72KC-TFE	575	3	8.2	54	3.56	0	
ZR72KCE-TF5	200/230	3	20.7	156	0.562	0	
ZR72KCE-TF7	380	3	10.7	70	1.92	0	
ZR72KCE-TFD	460	3	10	75	2.27	0	
ZR72KCE-TFE	575	3	8.2	54	3.56	0	
ZR72KS-TFD	380/460	3	10	75	2.27	0	
ZR80KW-PFV	208/230	1	31.4	176	1.408	0.346	014-0064-35

‡ † See Section F Introduction for more information.

FF50

**Electrical Data - Copeland Scroll®**

Model	Volts	PH	Max RLA	LRA	Winding Resistance		Run Cap PN ‡
					Start or Line/Line †	Run	
ZR81KC-TF5	200/230	3	25	164	0.501	0	
ZR81KC-TF7	380	3	12.1	100	1.79	0	
ZR81KC-TFD	460	3	12.1	100	1.79	0	
ZR81KC-TFE	575	3	9.3	78	2.76	0	
ZR81KCE-TF5	200/230	3	25	164	0.501	0	
ZR81KCE-TF7	380	3	12.1	100	1.79	0	
ZR81KCE-TFD	460	3	12.1	100	1.79	0	
ZR81KCE-TFE	575	3	9.3	78	2.76	0	
ZR84KC-TF5	200/230	3	28.6	196	0.44	0	
ZR84KC-TF7	380	3	15.7	135	1.174	0	
ZR84KC-TFD	460	3	14.3	100	1.764	0	
ZR84KC-TFE	575	3	9.6	90	2.989	0	
ZR84KCE-TF5	200/230	3	28.6	196	0.44	0	
ZR84KCE-TF7	380	3	15.7	135	1.174	0	
ZR84KCE-TFD	460	3	14.3	100	1.764	0	
ZR84KCE-TFE	575	3	9.6	90	2.989	0	
ZR90K3-TW5	200/230	3	26.4	189	0.348	0	
ZR90K3-TW7	380	3	16.6	112	1.03	0	
ZR90K3-TWC	208/230	3	26.4	189	0.37	0	
ZR90K3-TWD	460	3	13.9	99	1.41	0	
ZR90K3-TWE	575	3	10.1	74	2.3	0	
ZR90K3E-TW5	200/230	3	33.6	189	0.348	0	
ZR90K3E-TW7	380	3	16.6	112	1.03	0	
ZR90K3E-TWC	208/230	3	33.6	189	0.37	0	
ZR90K3E-TWD	460	3	15.4	99	1.41	0	
ZR90K3E-TWE	575	3	11.4	74	2.3	0	

‡ † See Section F Introduction for more information.

FF51



**Electrical Data - Copeland Scroll®**

Model	Volts	PH	Max RLA	LRA	Winding Resistance		Run Cap PN ‡
					Start or Line/Line †	Run	
ZR94KC-TF5	200/230	3	32.1	195	0.4	0	
ZR94KC-TF7	380	3	16.7	123	1.051	0	
ZR94KC-TFD	460	3	16.4	95	1.799	0	
ZR94KC-TFE	575	3	12	80	2.55	0	
ZR94KCE-TF5	200/230	3	32.1	195	0.4	0	
ZR94KCE-TF7	380	3	17.1	123	1.051	0	
ZR94KCE-TFD	460	3	16.4	95	1.799	0	
ZR94KCE-TFE	575	3	12	80	2.55	0	
ZRD125KC-TF5	200/230	3	41.4	239	0.306	0	
ZRD125KC-TF7	380	3	23.6	145	0.85	0	
ZRD125KC-TFD	460	3	19.2	125	1.227	0	
ZRD125KC-TFE	575	3	13.8	80	2.55	0	
ZRD125KCE-TF5	200/230	3	41.4	239	0.306	0	
ZRD125KCE-TF7	380	3	23.6	145	0.85	0	
ZRD125KCE-TFD	460	3	19.2	125	1.227	0	
ZRD125KCE-TFE	575	3	13.8	80	2.55	0	
ZRD36KC-PFV	208/230	1	18.6	95	1.39	0.65	014-0064-29
ZRD36KC-TF5	200/230	3	12.1	77	1.234	0	
ZRD36KCE-PFV	208/230	1	18.6	95	1.39	0.65	014-0064-29
ZRD36KCE-TF5	200/230	3	11.4	77	1.234	0	
ZRD42KC-TFD	460	3	7.1	44	4.03	0	
ZRD42KCE-PFJ	265	1	19.3	98	1.65	0.691	014-0064-18
ZRD42KCE-TFD	460	3	7.1	44	4.03	0	
ZRD48KC-PFV	208/230	1	22.9	137	1.339	0.462	014-0064-26
ZRD48KC-TF5	200/230	3	17.1	110	0.432	0	
ZRD48KC-TF7	380	3	9.3	54	2.76	0	

‡ † See Section F Introduction for more information.

FF52

**Electrical Data - Copeland Scroll®**

Model	Volts	PH	Max RLA	LRA	Winding Resistance		Run Cap PN ‡
					Start or Line/Line †	Run	
ZRD48KC-TFD	460	3	7.9	46	3.88	0	
ZRD48KCE-PFV	208/230	1	22.9	137	1.339	0.462	014-0064-26
ZRD48KCE-TF5	200/230	3	17.1	110	0.432	0	
ZRD48KCE-TF7	380	3	9.3	54	2.76	0	
ZRD48KCE-TFD	460	3	7.9	46	3.88	0	
ZRD49KC-PFV	208/230	1	26.4	129	0.779	0.432	014-0064-26
ZRD49KC-TF5	200/230	3	15	115	0.911	0	
ZRD49KC-TF7	380	3	8	57	2.78	0	
ZRD49KC-TFD	460	3	7.4	47.5	3.64	0	
ZRD49KCE-TF5	200/230	3	15.7	115	0.911	0	
ZRD49KCE-TF7	380	3	8	57	2.78	0	
ZRD49KCE-TFD	460	3	7.4	47.5	3.64	0	
ZRD61KC-PFV	208/230	1	32.1	148	0.667	0.362	014-0064-27
ZRD61KC-TF5	200/230	3	20.7	137	0.612	0	
ZRD61KC-TF7	380	3	10.7	64	2.3	0	
ZRD61KC-TFD	460	3	10	62	2.8	0	
ZRD61KCE-TFE	575	3	7.1	53	4.333	0	
ZRD61KCE-PFV	208/230	1	32.1	148	0.667	0.362	014-0064-27
ZRD61KCE-TF5	200/230	3	20.7	137	0.612	0	
ZRD61KCE-TF7	380	3	10.7	64	2.3	0	
ZRD61KCE-TFD	460	3	9.1	62	2.8	0	
ZRD68KC-TFD	460	3	11.1	75	2.27	0	
ZRD68KCE-TFD	460	3	11.1	75	2.27	0	
ZRD72KC-TF5	200/230	3	20.7	156	0.562	0	
ZRD72KC-TF7	380	3	12.5	70	1.92	0	
ZRD72KC-TFD	460	3	10	70	2.27	0	

‡ † See Section F Introduction for more information.

FF53

**Electrical Data - Copeland Scroll®**

Model	Volts	PH	Max RLA	LRA	Winding Resistance		Run Cap PN ‡
					Start or Line/Line †	Run	
ZRD72KCE-TF5	200/230	3	20.7	156	0.562	0	
ZRD72KCE-TF7	380	3	12.5	70	1.92	0	
ZRD72KCE-TFD	460	3	10	70	2.27	0	
ZRD81KC-TF7	380	3	14.3	78	1.79	0	
ZRD81KC-TFD	460	3	12.1	100	1.79	0	
ZRD81KCE-TF7	380	3	14.3	78	1.79	0	
ZRD81KCE-TFD	460	3	12.1	100	1.79	0	
ZRD94KC-TF5	200/230	3	32.1	195	0.4	0	
ZRD94KC-TF7	380	3	16.7	123	1.051	0	
ZRD94KC-TFD	460	3	16.4	95	1.799	0	
ZRD94KC-TFE	575	3	12	80	2.55	0	
ZRD94KCE-TF5	200/230	3	32.1	195	0.4	0	
ZRD94KCE-TF7	380	3	16.7	123	1.051	0	
ZRD94KCE-TFD	460	3	16.4	95	1.799	0	
ZRD94KCE-TFE	575	3	12	80	2.55	0	
ZRDT12MC-TF5	200/230	3					
ZRDT12MC-TF7	380	3					
ZRDT12MC-TFD	460	3					
ZRDT12MCE-TF5200/230		3					
ZRDT12MCE-TF7	380	3					
ZRDT12MCE-TFD	460	3					
ZRDT14MC-TF5	200/230	3					
ZRDT14MC-TF7	380	3					
ZRDT14MC-TFD	460	3					
ZRDT14MCE-TF5200/230		3					
ZRDT14MCE-TF7	380	3					

‡ † See Section F Introduction for more information.

FF54

### Electrical Data - Copeland Scroll®

Model	Volts	PH	Max RLA	LRA	Winding Resistance		Run Cap PN ‡
					Start or Line/Line †	Run	
ZRDT14MCE-TFD	460	3					
ZRDT16MC-TF7	380	3					
ZRDT16MC-TFD	460	3					
ZRDT16MCE-TF7	380	3					
ZRDT16MCE-TFD	460	3					
ZRDT96KC-TF7	380	3					
ZRDT96KC-TFD	460	3					
ZRDT96KCE-TF7	380	3					
ZRDT96KCE-TFD	460	3					
ZRDU11MC-TF5	200/230	3					
ZRDU11MC-TF5	200/230	3					
ZRDU11MC-TF7	380	3					
ZRDU11MC-TF7	380	3					
ZRDU11MC-TFD	460	3					
ZRDU11MC-TFD	460	3					
ZRDU11MCE-TF5200/230		3					
ZRDU11MCE-TF7	380	3					
ZRDU11MCE-TFD	460	3					
ZRDU13MC-TF5	200/230	3					
ZRDU13MC-TF5	200/230	3					
ZRDU13MC-TF7	380	3					
ZRDU13MC-TF7	380	3					
ZRDU13MC-TFD	460	3					
ZRDU13MC-TFD	460	3					
ZRDU13MCE-TF5200/230		3					
ZRDU13MCE-TF5200/230		3					

‡ † See Section F Introduction for more information.

FF55

**Electrical Data - Copeland Scroll®**

Model	Volts	PH	Max RLA	LRA	Winding Resistance		Run Cap PN ‡
					Start or Line/Line †	Run	
ZRDU13MCE-TF7	380	3					
ZRDU13MCE-TF7	380	3					
ZRDU13MCE-TFD	460	3					
ZRDU13MCE-TFD	460	3					
ZRH49KJE-TF5	200/230	3	15	99	0.911	0	
ZRH49KJE-TF7	380	3	8.6	57	0.911	0	
ZRH49KJE-TFD	460	3	8.2	49.5	3.64	0	
ZRH49KJE-TFE	575	3	6.4	40	5.72	0	
ZRH61KJE-TF5	200/230	3	21.4	123	0.686	0	
ZRH61KJE-TF7	380	3	11.4	64	0.686	0	
ZRH61KJE-TFD	460	3	9.6	62	2.75	0	
ZRH72KJE-TF5	200/230	3	23.9	156	0.501	0	
ZRH72KJE-TF7	380	3	12.9	70	2.27	0	
ZRH72KJE-TFD	460	3	9.3	70	2.27	0	
ZRI108KC-TF7	380	3	19.6	140	0.93	0	
ZRI125KC-TF7	380	3	23.9	145	0.85	0	
ZRI144KC-TF7	380	3	24.3	145	0.85	0	
ZRI61KC-TFD	460	3	10.4	62	2.75	0	
ZRJ61KC-TFD	460	3	10.7	62	2.75	0	
ZRJ72KC-TFD	460	3	12.5	100	1.79	0	
ZRJU13MC-TFD	460	3					
ZRS43K4-PFV	208/230	1	23.9	116	1.227	0.517	014-0064-25
ZRS43K4-TF5	200/230	3	14.3	91	0.994	0	
ZRS43K4-TFD	460	3	6.8	46	3.88	0	
ZRS52K4-PFV	208/230	1	24.6	118	0.601	0.49	014-0064-27
ZRS52K4-TF5	200/230	3	18.9	123	0.686	0	

‡ † See Section F Introduction for more information.

FF56

**Electrical Data - Copeland Scroll®**

Model	Volts	PH	Max RLA	LRA	Winding Resistance		Run Cap PN ‡
					Start or Line/Line †	Run	
ZRS52K4-TFD	460	3	9.4	62	2.8	0	
ZRT108K3-PFV	208/230	1					
ZRT108K3-PFV	208/230	1					
ZRT108K3-TF5	200/230	3					
ZRT108K3-TF5	200/230	3					
ZRT108K3-TFD	460	3					
ZRT108K3-TFD	460	3					
ZRT108K3-TFE	575	3					
ZRT108K3-TFE	575	3					
ZRT108K3E-TFD	460	3					
ZRT108K3E-TFD	460	3					
ZRT108K3E-TFE	575	3					
ZRT108K3E-TFE	575	3					
ZRT108KC-TF7	380	3					
ZRT108KC-TF7	380	3					
ZRT108KS-TFD	460	3					
ZRT108KSE-TFD	460	3					
ZRT114K3-PFV	208/230	1					
ZRT114K3-PFV	208/230	1					
ZRT114K3-TF5	200/230	3					
ZRT114K3-TF5	200/230	3					
ZRT114K3-TFD	460	3					
ZRT114K3-TFD	460	3					
ZRT114K3-TFE	575	3					
ZRT114K3-TFE	575	3					
ZRT114KS-TFD	460	3					

‡ † See Section F Introduction for more information.

FF57

**Electrical Data - Copeland Scroll®**

Model	Volts	PH	Max RLA	LRA	Winding Resistance		Run Cap PN ‡
					Start or Line/Line †	Run	
ZRT114KSE-TFD	460	3					
ZRT122K3-PFV	208/230	1					
ZRT122K3-PFV	208/230	1					
ZRT122K3-TF5	200/230	3					
ZRT122K3-TF5	200/230	3					
ZRT122K3-TFD	460	3					
ZRT122K3-TFD	460	3					
ZRT122K3-TFE	575	3					
ZRT122K3-TFE	575	3					
ZRT122K3E-PFV	208/230	1					
ZRT122K3E-PFV	208/230	1					
ZRT122K3E-TF5	200/230	3					
ZRT122K3E-TF5	200/230	3					
ZRT122K3E-TFD	460	3					
ZRT122K3E-TFD	460	3					
ZRT122KCE-TFD	460	3					
ZRT122KCE-TFD	460	3					
ZRT122KS-TF5	200/230	3					
ZRT122KS-TFD	460	3					
ZRT122KSE-TF5	200/230	3					
ZRT122KSE-TFD	460	3					
ZRT136KC-TF5	200/230	3					
ZRT136KC-TF5	200/230	3					
ZRT136KC-TF7	380	3					
ZRT136KC-TF7	380	3					
ZRT136KC-TFD	460	3					

‡ † See Section F Introduction for more information.

FF58

**Electrical Data - Copeland Scroll®**

Model	Volts	PH	Max RLA	LRA	Winding Resistance		Run Cap PN ‡
					Start or Line/Line †	Run	
ZRT136KC-TFD	460	3					
ZRT136KC-TFE	575	3					
ZRT136KC-TFE	575	3					
ZRT136KCE-TF5 200/230		3					
ZRT136KCE-TFD	460	3					
ZRT136KCE-TFD	460	3					
ZRT136KCE-TFE	575	3					
ZRT136KCE-TFE	575	3					
ZRT144KC-TF5 200/230		3					
ZRT144KC-TF5 200/230		3					
ZRT144KC-TF7	380	3					
ZRT144KC-TF7	380	3					
ZRT144KC-TFD	460	3					
ZRT144KC-TFD	460	3					
ZRT144KC-TFE	575	3					
ZRT144KC-TFE	575	3					
ZRT144KCE-TF5 200/230		3					
ZRT144KCE-TF5 200/230		3					
ZRT144KCE-TFD	460	3					
ZRT144KCE-TFD	460	3					
ZRT144KCE-TFE	575	3					
ZRT144KCE-TFE	575	3					
ZRT162KC-TF5 200/230		3					
ZRT162KC-TF5 200/230		3					
ZRT162KC-TF7	380	3					
ZRT162KC-TFD	460	3					

‡ † See Section F Introduction for more information.

FF59



### Electrical Data - Copeland Scroll®

Model	Volts	PH	Max RLA	LRA	Winding Resistance		Run Cap PN ‡
					Start or Line/Line †	Run	
ZRT162KC-TFD	460	3					
ZRT162KCE-TF5	200/230	3					
ZRT162KCE-TF5	200/230	3					
ZRT162KCE-TF7	380	3					
ZRT162KCE-TF7	380	3					
ZRT162KCE-TFD	460	3					
ZRT162KCE-TFD	460	3					
ZRT168KC-TF5	200/230	3					
ZRT168KC-TF5	200/230	3					
ZRT168KC-TF7	380	3					
ZRT168KC-TF7	380	3					
ZRT168KC-TFD	460	3					
ZRT168KC-TFD	460	3					
ZRT168KC-TFE	575	3					
ZRT168KC-TFE	575	3					
ZRT168KCE-TF5	200/230	3					
ZRT168KCE-TF5	200/230	3					
ZRT168KCE-TF7	380	3					
ZRT168KCE-TF7	380	3					
ZRT168KCE-TFD	460	3					
ZRT168KCE-TFD	460	3					
ZRT168KCE-TFE	575	3					
ZRT168KCE-TFE	575	3					
ZRT180K3-TW5	200/230	3					
ZRT180K3-TW7	380	3					
ZRT180K3-TWC	208/230	3					

‡ † See Section F Introduction for more information.

FF60

### Electrical Data - Copeland Scroll®

Model	Volts	PH	Max RLA	LRA	Winding Resistance		Run Cap PN ‡
					Start or Line/Line †	Run	
ZRT180K3-TWD	460	3					
ZRT180K3-TWE	575	3					
ZRT180K3E-TWC208/230		3					
ZRT180K3E-TWD	460	3					
ZRT180K3E-TWE	575	3					
ZRT188KC-TF5	200/230	3					
ZRT188KC-TF5	200/230	3					
ZRT188KC-TF7	380	3					
ZRT188KC-TF7	380	3					
ZRT188KC-TFD	460	3					
ZRT188KC-TFD	460	3					
ZRT188KC-TFE	575	3					
ZRT188KC-TFE	575	3					
ZRT188KCE-TF5	200/230	3					
ZRT188KCE-TF5	200/230	3					
ZRT188KCE-TF7	380	3					
ZRT188KCE-TF7	380	3					
ZRT188KCE-TFD	460	3					
ZRT188KCE-TFD	460	3					
ZRT188KCE-TFE	575	3					
ZRT188KCE-TFE	575	3					
ZRT216KC-TF5	200/230	3					
ZRT216KC-TF5	200/230	3					
ZRT216KC-TF7	380	3					
ZRT216KC-TF7	380	3					
ZRT216KC-TFD	460	3					

‡ † See Section F Introduction for more information.

FF61

### Electrical Data - Copeland Scroll®

Model	Volts	PH	Max RLA	LRA	Winding Resistance		Run Cap PN ‡
					Start or Line/Line †	Run	
ZRT216KC-TFD	460	3					
ZRT216KC-TFE	575	3					
ZRT216KC-TFE	575	3					
ZRT216KCE-TF5 200/230		3					
ZRT216KCE-TF5 200/230		3					
ZRT216KCE-TF7	380	3					
ZRT216KCE-TF7	380	3					
ZRT216KCE-TFD	460	3					
ZRT216KCE-TFD	460	3					
ZRT216KCE-TFE	575	3					
ZRT216KCE-TFE	575	3					
ZRT220K3-TW7	380	3					
ZRT220K3-TWC 208/230		3					
ZRT220K3-TWD	460	3					
ZRT220K3-TWE	575	3					
ZRT220K3E-TW7	380	3					
ZRT220K3E-TWC208/230		3					
ZRT220K3E-TWD	460	3					
ZRT240K3-TW5 200/230		3					
ZRT240K3-TW7	380	3					
ZRT240K3-TWC 208/230		3					
ZRT240K3-TWD	460	3					
ZRT240K3-TWE	575	3					
ZRT240K3E-TWC208/230		3					
ZRT240K3E-TWD	460	3					
ZRT240K3E-TWE	575	3					

‡ † See Section F Introduction for more information.

FF62

### Electrical Data - Copeland Scroll®

Model	Volts	PH	Max RLA	LRA	Winding Resistance		Run Cap PN ‡
					Start or Line/Line †	Run	
ZRT250KC-TF5	200/230	3					
ZRT250KC-TF5	200/230	3					
ZRT250KC-TF7	380	3					
ZRT250KC-TF7	380	3					
ZRT250KC-TFD	460	3					
ZRT250KC-TFD	460	3					
ZRT250KC-TFE	575	3					
ZRT250KC-TFE	575	3					
ZRT250KCE-TF5	200/230	3					
ZRT250KCE-TF5	200/230	3					
ZRT250KCE-TF7	380	3					
ZRT250KCE-TF7	380	3					
ZRT250KCE-TFD	460	3					
ZRT250KCE-TFD	460	3					
ZRT250KCE-TFE	575	3					
ZRT250KCE-TFE	575	3					
ZRT288KC-TF5	200/230	3					
ZRT288KC-TF5	200/230	3					
ZRT288KC-TF7	380	3					
ZRT288KC-TF7	380	3					
ZRT288KC-TFD	460	3					
ZRT288KC-TFD	460	3					
ZRT288KC-TFE	575	3					
ZRT288KC-TFE	575	3					
ZRT320K3-TW5	200/230	3					
ZRT320K3-TW7	380	3					

‡ † See Section F Introduction for more information.

FF63

### Electrical Data - Copeland Scroll®

Model	Volts	PH	Max RLA	LRA	Winding Resistance		Run Cap PN ‡
					Start or Line/Line †	Run	
ZRT320K3-TWC	208/230	3					
ZRT320K3-TWD	460	3					
ZRT320K3-TWE	575	3					
ZRT320K3E-TWC208/230		3					
ZRT320K3E-TWD	460	3					
ZRT320K3E-TWE	575	3					
ZRT320KC-TFD	460	3					
ZRT320KC-TW5	200/230	3					
ZRT320KC-TW7	380	3					
ZRT320KC-TWD	460	3					
ZRT320KC-TWE	575	3					
ZRT320KCE-TFD	460	3					
ZRT320KCE-TW5200/230		3					
ZRT320KCE-TW7	380	3					
ZRT320KCE-TWD	460	3					
ZRT320KCE-TWE	575	3					
ZRT380K3-TW5	200/230	3					
ZRT380K3-TW7	380	3					
ZRT380K3-TWC	208/230	3					
ZRT380K3-TWD	460	3					
ZRT380K3-TWE	575	3					
ZRT380K3E-TWC208/230		3					
ZRT380K3E-TWD	460	3					
ZRT380K3E-TWE	575	3					
ZRT380KC-TFD	460	3					
ZRT380KC-TW5	200/230	3					

‡ † See Section F Introduction for more information.

FF64

**Electrical Data - Copeland Scroll®**

Model	Volts	PH	Max RLA	LRA	Winding Resistance		Run Cap PN ‡
					Start or Line/Line †	Run	
ZRT380KC-TW7	380	3					
ZRT380KC-TWD	460	3					
ZRT380KC-TWE	575	3					
ZRT380KCE-TFD	460	3					
ZRT380KCE-TW5200/230	380	3					
ZRT380KCE-TW7	380	3					
ZRT380KCE-TWD	460	3					
ZRT380KCE-TWE	575	3					
ZRT500KC-TW5	200/230	3					
ZRT500KC-TW5	200/230	3					
ZRT500KC-TW7	380	3					
ZRT500KC-TW7	380	3					
ZRT500KC-TWC	208/230	3					
ZRT500KC-TWC	208/230	3					
ZRT500KC-TWD	460	3					
ZRT500KC-TWD	460	3					
ZRT500KC-TWE	575	3					
ZRT500KC-TWE	575	3					
ZRT500KCE-TW5200/230	380	3					
ZRT500KCE-TW5200/230	380	3					
ZRT500KCE-TW7	380	3					
ZRT500KCE-TW7	380	3					
ZRT500KCE-TWC208/230	380	3					
ZRT500KCE-TWC208/230	380	3					
ZRT500KCE-TWD	460	3					
ZRT500KCE-TWD	460	3					

‡ † See Section F Introduction for more information.

FF65

**Electrical Data - Copeland Scroll®**

Model	Volts	PH	Max RLA	LRA	Winding Resistance		Run Cap PN ‡
					Start or Line/Line †	Run	
ZRT500KCE-TWE	575	3					
ZRT500KCE-TWE	575	3					
ZRT600KC-TW5	208/230	3					
ZRT600KC-TW5	208/230	3					
ZRT600KC-TW7	380	3					
ZRT600KC-TW7	380	3					
ZRT600KC-TWC	208/230	3					
ZRT600KC-TWC	208/230	3					
ZRT600KC-TWD	460	3					
ZRT600KC-TWD	460	3					
ZRT600KC-TWE	575	3					
ZRT600KC-TWE	575	3					
ZRT600KCE-TW5208/230		3					
ZRT600KCE-TW5208/230		3					
ZRT600KCE-TW7	380	3					
ZRT600KCE-TW7	380	3					
ZRT600KCE-TWC208/230		3					
ZRT600KCE-TWC208/230		3					
ZRT600KCE-TWD	460	3					
ZRT600KCE-TWD	460	3					
ZRT600KCE-TWE	575	3					
ZRT600KCE-TWE	575	3					
ZRT760KC-TW5	200/230	3					
ZRT760KC-TW5	200/230	3					
ZRT760KC-TW7	380	3					
ZRT760KC-TW7	380	3					

‡ † See Section F Introduction for more information.

FF66

### Electrical Data - Copeland Scroll®

Model	Volts	PH	Max RLA	LRA	Winding Resistance		Run Cap PN ‡
					Start or Line/Line †	Run	
ZRT760KC-TWC 208/230	208/230	3					
ZRT760KC-TWC 208/230	208/230	3					
ZRT760KC-TWD 460	460	3					
ZRT760KC-TWD 460	460	3					
ZRT760KC-TWE 575	575	3					
ZRT760KC-TWE 575	575	3					
ZRT760KCE-TW5200/230	208/230	3					
ZRT760KCE-TW5200/230	208/230	3					
ZRT760KCE-TW7 380	380	3					
ZRT760KCE-TW7 380	380	3					
ZRT760KCE-TWC208/230	208/230	3					
ZRT760KCE-TWC208/230	208/230	3					
ZRT760KCE-TWD 460	460	3					
ZRT760KCE-TWD 460	460	3					
ZRT760KCE-TWE 575	575	3					
ZRT760KCE-TWE 575	575	3					
ZRT90K3-PFV 208/230	208/230	1					
ZRT90K3-PFV 208/230	208/230	1					
ZRT90K3-TF5 200/230	200/230	3					
ZRT90K3-TF5 200/230	200/230	3					
ZRT90K3-TFD 460	460	3					
ZRT90K3-TFD 460	460	3					
ZRT90K3E-PFV 208/230	208/230	1					
ZRT90KC-PFV 208/230	208/230	1					
ZRT90KC-PFV 208/230	208/230	1					
ZRT90KC-TF5 200/230	200/230	3					

‡ † See Section F Introduction for more information.

FF67



**Electrical Data - Copeland Scroll®**

Model	Volts	PH	Max RLA	LRA	Winding Resistance		Run Cap PN ‡
					Start or Line/Line †	Run	
ZRT90KC-TF5	200/230	3					
ZRT90KC-TFD	460	3					
ZRT90KC-TFD	460	3					
ZRT90KC-TFE	575	3					
ZRT90KC-TFE	575	3					
ZRT92K3-PFV	208/230	1					
ZRT92K3-PFV	208/230	1					
ZRT92K3-TF5	200/230	3					
ZRT92K3-TF5	200/230	3					
ZRT92K3-TFD	460	3					
ZRT92K3-TFD	460	3					
ZRT92K3-TFE	575	3					
ZRT92K3-TFE	575	3					
ZRT96K3-PFV	208/230	1					
ZRT96K3-PFV	208/230	1					
ZRT96K3-TF5	200/230	3					
ZRT96K3-TF5	200/230	3					
ZRT96K3-TFD	460	3					
ZRT96K3-TFD	460	3					
ZRT96K3-TFE	575	3					
ZRT96K3E-PFV	208/230	1					
ZRT96K3E-PFV	208/230	1					
ZRT96K3E-TF5	200/230	3					
ZRT96K3E-TF5	200/230	3					
ZRT96K3E-TFD	460	3					

‡ † See Section F Introduction for more information.

FF68

### Electrical Data - Copeland Scroll®

Model	Volts	PH	Max RLA	LRA	Winding Resistance		Run Cap PN ‡
					Start or Line/Line †	Run	
ZRT96K3E-TFD	460	3					
ZRT96K3E-TFE	575	3					
ZRT96KC-PFV	208/230	1					
ZRT96KC-PFV	208/230	1					
ZRT96KC-TF5	200/230	3					
ZRT96KC-TF5	200/230	3					
ZRT96KC-TFD	460	3					
ZRT96KC-TFD	460	3					
ZRT96KCE-TF5	200/230	3					
ZRT96KCE-TF5	200/230	3					
ZRT96KCE-TFD	460	3					
ZRT96KCE-TFD	460	3					
ZRT98K3-PFV	208/230	1					
ZRT98K3-PFV	208/230	1					
ZRT98K3-TF5	200/230	3					
ZRT98K3-TF5	200/230	3					
ZRT98K3-TFD	460	3					
ZRT98K3-TFD	460	3					
ZRT98K3-TFE	575	3					
ZRT98K3-TFE	575	3					
ZRU103K3-TF5	200/230	3					
ZRU103K3-TF5	200/230	3					
ZRU103K3-TFD	460	3					
ZRU103K3-TFD	460	3					
ZRU103K3-TFE	575	3					
ZRU103K3-TFE	575	3					

‡ † See Section F Introduction for more information.

FF69

### Electrical Data - Copeland Scroll®

Model	Volts	PH	Max RLA	LRA	Winding Resistance		Run Cap PN ‡
					Start or Line/Line †	Run	
ZRU140KC-TF5	200/230	3					
ZRU140KC-TF5	200/230	3					
ZRU140KC-TF7	380	3					
ZRU140KC-TF7	380	3					
ZRU140KC-TFD	460	3					
ZRU140KC-TFD	460	3					
ZRU140KC-TFE	575	3					
ZRU140KC-TFE	575	3					
ZRU178KC-TF5	200/230	3					
ZRU178KC-TF5	200/230	3					
ZRU178KC-TF7	380	3					
ZRU178KC-TF7	380	3					
ZRU178KC-TFD	460	3					
ZRU178KC-TFD	460	3					
ZRU178KC-TFE	575	3					
ZRU178KC-TFE	575	3					
ZRU280K3-TW5	200/230	3					
ZRU280K3-TW7	380	3					
ZRU280K3-TWC	208/230	3					
ZRU280K3-TWD	460	3					
ZRU280K3-TWE	575	3					
ZRU280K3E-TWC208/230		3					
ZRU280K3E-TWD	460	3					
ZRU280K3E-TWE	575	3					
ZRU285KC-TFD	460	3					
ZRU285KC-TX5	200/230	3					

‡ † See Section F Introduction for more information.

FF70

**Electrical Data - Copeland Scroll®**

Model	Volts	PH	Max RLA	LRA	Winding Resistance		Run Cap PN ‡
					Start or Line/Line †	Run	
ZRU285KC-TX7	380	3					
ZRU285KC-TXD	460	3					
ZRU285KC-TXE	575	3					
ZRU285KCE-TFD	460	3					
ZRU285KCE-TX5200/230		3					
ZRU285KCE-TX7	380	3					
ZRU285KCE-TXD	460	3					
ZRU285KCE-TXE	575	3					
ZRU310K3-TW5	200/230	3					
ZRU310K3-TW7	380	3					
ZRU310K3-TWC	208/230	3					
ZRU310K3-TWD	460	3					
ZRU310K3-TWE	575	3					
ZRU310K3E-TWC208/230		3					
ZRU310K3E-TWD	460	3					
ZRU310K3E-TWE	575	3					
ZRU315KC-TFD	460	3					
ZRU315KC-TX5	200/230	3					
ZRU315KC-TX7	380	3					
ZRU315KC-TXD	460	3					
ZRU315KC-TXE	575	3					
ZRU315KCE-TFD	460	3					
ZRU315KCE-TX5200/230		3					
ZRU315KCE-TX7	380	3					
ZRU315KCE-TXD	460	3					
ZRU315KCE-TXE	575	3					

‡ † See Section F Introduction for more information.

FF71

### Electrical Data - Copeland Scroll®

Model	Volts	PH	Max RLA	LRA	Winding Resistance		Run Cap PN ‡
					Start or Line/Line †	Run	
ZRU334KC-TFD	460	3					
ZRU334KC-TX5	200/230	3					
ZRU334KC-TX7	380	3					
ZRU334KC-TXD	460	3					
ZRU334KC-TXE	575	3					
ZRU334KCE-TFD	460	3					
ZRU334KCE-TX5	200/230	3					
ZRU334KCE-TX7	380	3					
ZRU334KCE-TXD	460	3					
ZRU334KCE-TXE	575	3					
ZRU350K3-TW5	200/230	3					
ZRU350K3-TW7	380	3					
ZRU350K3-TWC	208/230	3					
ZRU350K3-TWD	460	3					
ZRU350K3-TWE	575	3					
ZRU350K3E-TWC	208/230	3					
ZRU350K3E-TWD	460	3					
ZRU350K3E-TWE	575	3					
ZRU350KC-TFD	460	3					
ZRU350KC-TW5	200/230	3					
ZRU350KC-TW7	380	3					
ZRU350KC-TWD	460	3					
ZRU350KC-TWE	575	3					
ZRU350KCE-TFD	460	3					
ZRU350KCE-TW5	200/230	3					
ZRU350KCE-TW7	380	3					

‡ † See Section F Introduction for more information.

FF72

### Electrical Data - Copeland Scroll®

Model	Volts	PH	Max RLA	LRA	Winding Resistance		Run Cap PN ‡
					Start or Line/Line †	Run	
ZRU350KCE-TWD 460	460	3					
ZRU350KCE-TWE 575	575	3					
ZRU440KC-TW7 380	380	3					
ZRU440KC-TW7 380	380	3					
ZRU440KC-TWC 208/230	208/230	3					
ZRU440KC-TWC 208/230	208/230	3					
ZRU440KC-TWD 460	460	3					
ZRU440KC-TWD 460	460	3					
ZRU440KC-TWE 575	575	3					
ZRU440KC-TWE 575	575	3					
ZRU440KCE-TWD 460	460	3					
ZRU440KCE-TWE 575	575	3					
ZRU550KC-TW5 200/230	200/230	3					
ZRU550KC-TW5 208/230	208/230	3					
ZRU550KC-TW7 380	380	3					
ZRU550KC-TWC 208/230	208/230	3					
ZRU550KC-TWD 460	460	3					
ZRU550KC-TWE 575	575	3					
ZRU550KCE-TW5200/230	5200/230	3					
ZRU550KCE-TW5208/230	5208/230	3					
ZRU550KCE-TW7 380	380	3					
ZRU550KCE-TWC208/230	208/230	3					
ZRU550KCE-TWD 460	460	3					
ZRU550KCE-TWE 575	575	3					
ZRY114MC-TWD 460	460	3					
ZRY114MCE-TWD 460	460	3					

‡ † See Section F Introduction for more information.

FF73

**Electrical Data - Copeland Scroll®**

Model	Volts	PH	Max RLA	LRA	Winding Resistance		Run Cap PN ‡
					Start or Line/Line †	Run	
ZRY324KC-TF5	200/230	3					
ZRY324KC-TF7	380	3					
ZRY324KC-TFD	460	3					
ZRY324KC-TFE	575	3					
ZRY324KCE-TF5	200/230	3					
ZRY324KCE-TF7	380	3					
ZRY324KCE-TFD	460	3					
ZRY324KCE-TFE	575	3					
ZRY375KC-TF5	200/230	3					
ZRY375KC-TF7	380	3					
ZRY375KC-TFD	460	3					
ZRY375KC-TFE	575	3					
ZRY375KCE-TF5	200/230	3					
ZRY375KCE-TF7	380	3					
ZRY375KCE-TFD	460	3					
ZRY375KCE-TFE	575	3					
ZRY432KC-TF5	200/230	3					
ZRY432KC-TF7	380	3					
ZRY432KC-TFD	460	3					
ZRY432KC-TFE	575	3					
ZRY432KCE-TF5	200/230	3					
ZRY432KCE-TF7	380	3					
ZRY432KCE-TFD	460	3					
ZRY432KCE-TFE	575	3					
ZRY480K3-TW5	200/230	3					
ZRY480K3-TW7	380	3					

‡ † See Section F Introduction for more information.

FF74

**Electrical Data - Copeland Scroll®**

Model	Volts	PH	Max RLA	LRA	Winding Resistance		Run Cap PN ‡
					Start or Line/Line †	Run	
ZRY480K3-TWC 208/230		3					
ZRY480K3-TWD 460		3					
ZRY480K3-TWE 575		3					
ZRY480K3E-TW5200/230		3					
ZRY480K3E-TW7 380		3					
ZRY480K3E-TWC208/230		3					
ZRY480K3E-TWD 460		3					
ZRY480K3E-TWE 575		3					
ZRY480KC-TFD 460		3					
ZRY480KC-TW5 200/230		3					
ZRY480KC-TW7 380		3					
ZRY480KC-TWD 460		3					
ZRY480KC-TWE 575		3					
ZRY480KCE-TFD 460		3					
ZRY480KCE-TW5200/230		3					
ZRY480KCE-TW7 380		3					
ZRY480KCE-TWD 460		3					
ZRY480KCE-TWE 575		3					
ZRY570K3-TW5 200/230		3					
ZRY570K3-TW7 380		3					
ZRY570K3-TWC 208/230		3					
ZRY570K3-TWD 460		3					
ZRY570K3-TWE 575		3					
ZRY570K3E-TW5200/230		3					
ZRY570K3E-TW7 380		3					
ZRY570K3E-TWC208/230		3					

‡ † See Section F Introduction for more information.

FF75



### Electrical Data - Copeland Scroll®

Model	Volts	PH	Max RLA	LRA	Winding Resistance		Run Cap PN ‡
					Start or Line/Line †	Run	
ZRY570K3E-TWD	460	3					
ZRY570KC-TFD	460	3					
ZRY570KC-TW5	200/230	3					
ZRY570KC-TW7	380	3					
ZRY570KC-TWD	460	3					
ZRY570KC-TWE	575	3					
ZRY570KCE-TFD	460	3					
ZRY570KCE-TW5200/230		3					
ZRY570KCE-TW7	380	3					
ZRY570KCE-TWD	460	3					
ZRY570KCE-TWE	575	3					
ZRY750KC-TW5	200/230	3					
ZRY750KC-TW7	380	3					
ZRY750KC-TWC	208/230	3					
ZRY750KC-TWD	460	3					
ZRY750KC-TWE	575	3					
ZRY750KCE-TW5200/230		3					
ZRY750KCE-TW7	380	3					
ZRY750KCE-TWC208/230		3					
ZRY750KCE-TWD	460	3					
ZRY750KCE-TWE	575	3					
ZRY900KC-TW5	208/230	3					
ZRY900KC-TW7	380	3					
ZRY900KC-TWC	208/230	3					
ZRY900KC-TWD	460	3					
ZRY900KC-TWE	575	3					

‡ † See Section F Introduction for more information.

FF76

**Electrical Data - Copeland Scroll®**

Model	Volts	PH	Max RLA	LRA	Winding Resistance		Run Cap PN ‡
					Start or Line/Line †	Run	
ZRY900KCE-TW5208/230		3					
ZRY900KCE-TW7 380		3					
ZRY900KCE-TWC208/230		3					
ZRY900KCE-TWD 460		3					
ZRY900KCE-TWE 575		3					
ZRY930KC-TW7 380		3					
ZRY930KC-TWC 208/230		3					
ZRY930KC-TWD 460		3					
ZRY930KCE-TW7 380		3					
ZRY930KCE-TWC208/230		3					
ZRY930KCE-TWD 460		3					
ZS11M4-TW7 380		3	25	239	0.52	0	
ZS11M4-TWC 208/230		3	48.2	425	0.19	0	
ZS11M4-TWD 460		3	22.1	187	0.72	0	
ZS11M4-TWE 575		3	17.9	148	1.1	0	
ZS11M4E-TW7 380		3	32.5	239	0.52	0	
ZS11M4E-TWC 208/230		3	60	425	0.19	0	
ZS11M4E-TWD 460		3	28.2	187	0.72	0	
ZS11M4E-TWE 575		3	22.5	148	1.1	0	
ZS15K4-PFV 208/230		1	13.6	61	2.28	1.01	014-0064-08
ZS15K4-TF5 200/230		3	7.9	55	1.79	0	
ZS15K4-TFD 460		3	3.6	27	7.1	0	
ZS15K4E-PFV 208/230		1	13.6	61	2.28	1.01	014-0064-08
ZS15K4E-TF5 200/230		3	9.3	55	1.79	0	
ZS15K4E-TFD 460		3	4.3	27	7.1	0	
ZS19K4-PFV 208/230		1	16.4	73	1.72	0.833	014-0064-25

‡ † See Section F Introduction for more information.

FF77

**Electrical Data - Copeland Scroll®**

Model	Volts	PH	Max RLA	LRA	Winding Resistance		Run Cap PN ‡
					Start or Line/Line †	Run	
ZS19K4-TF5	200/230	3	7.9	63	1.46	0	
ZS19K4-TFD	460	3	3.9	31	5.94	0	
ZS19K4E-PFV	208/230	1	16.4	73	1.72	0.833	014-0064-25
ZS19K4E-TF5	200/230	3	9.6	63	1.46	0	
ZS19K4E-TFD	460	3	5	31	5.94	0	
ZS21K4-PFV	208/230	1	17.9	88	1.46	0.691	014-0064-29
ZS21K4-TF5	200/230	3	10	77	1.234	0	
ZS21K4-TFD	460	3	5	39	4.83	0	
ZS21K4E-PFV	208/230	1	16.4	88	1.46	0.691	014-0064-29
ZS21K4E-TF5	200/230	3	11.1	77	1.234	0	
ZS21K4E-TFD	460	3	5.7	39	4.83	0	
ZS21K4E-TFE	575	3	4.3	31	7.89	0	
ZS26K4-PFV	208/230	1	20.7	109	1.28	0.54	014-0064-26
ZS26K4-TF5	200/230	3	12.5	88	0.995	0	
ZS26K4-TFD	460	3	6.4	44	1.85	0	
ZS26K4E-PFV	208/230	1	20.7	109	1.28	0.54	014-0064-26
ZS26K4E-TF5	200/230	3	13.6	88	0.995	0	
ZS26K4E-TFD	460	3	7.1	44	1.85	0	
ZS26K4E-TFE	575	3	5	34	6.28	0	
ZS30K4-PFV	208/230	1	26.4	129	0.779	0.432	014-0064-26
ZS30K4-TF5	200/230	3	15	99	0.911	0	
ZS30K4-TFD	460	3	6.8	49.5	3.64	0	
ZS30K4E-PFV	208/230	1	26.8	129	0.779	0.432	014-0064-26
ZS30K4E-TF5	200/230	3	15	99	0.911	0	
ZS30K4E-TF7	380	3	8.2	57	2.78	0	
ZS30K4E-TFD	460	3	8.2	49.5	3.64	0	

‡ † See Section F Introduction for more information.

FF78

**Electrical Data - Copeland Scroll®**

Model	Volts	PH	Max RLA	LRA	Winding Resistance		Run Cap PN ‡
					Start or Line/Line †	Run	
ZS30K4E-TFE	575	3	8.2	40	5.72	0	
ZS38K4-PFJ	265	1	22.9	160	1.224	0.417	014-0064-26
ZS38K4-TF5	200/230	3	16.4	123	0.686	0	
ZS38K4-TFD	460	3	8.6	62	2.75	0	
ZS38K4E-PFJ	265	1	26.4	160	1.224	0.417	014-0064-26
ZS38K4E-PFV	208/230	1	31.8	169	0.605	0.329	014-0064-27
ZS38K4E-TF5	200/230	3	21.4	123	0.686	0	
ZS38K4E-TF7	380	3	11.4	64	2.28	0	
ZS38K4E-TFD	460	3	9.6	62	2.75	0	
ZS38K4E-TFE	575	3	7.9	50	4.31	0	
ZS45K4-TF5	200/230	3	20	156	0.501	0	
ZS45K4-TFD	460	3	8.9	70	2.27	0	
ZS45K4E-TF5	200/230	3	23.9	156	0.501	0	
ZS45K4E-TF7	380	3	12.6	70	1.92	0	
ZS45K4E-TFD	460	3	9.3	70	2.27	0	
ZS45K4E-TFE	575	3	7.9	54	3.56	0	
ZS56K4-TW7	380	3	14.3	112	1.03	0	
ZS56K4-TWC	208/230	3	22.9	189	0.37	0	
ZS56K4-TWD	460	3	11.4	99	1.41	0	
ZS56K4-TWE	575	3	8.9	74	2.3	0	
ZS56K4E-TW7	380	3	18.6	112	1.03	0	
ZS56K4E-TWC	208/230	3	30	189	0.37	0	
ZS56K4E-TWD	460	3	15.7	99	1.41	0	
ZS56K4E-TWE	575	3	8.9	74	2.3	0	
ZS75K4-TW7	380	3	16.6	151	0.72	0	
ZS75K4-TWC	208/230	3	30.1	278	0.26	0	

‡ † See Section F Introduction for more information.

FF79

**Electrical Data - Copeland Scroll®**

Model	Volts	PH	Max RLA	LRA	Winding Resistance		Run Cap PN ‡
					Start or Line/Line †	Run	
ZS75K4-TWD	460	3	16.4	127	1.02	0	
ZS75K4-TWE	575	3	11.6	100	1.7	0	
ZS75K4E-TW7	380	3	23.9	151	0.72	0	
ZS75K4E-TWC	208/230	3	43.6	278	0.26	0	
ZS75K4E-TWD	460	3	21.1	127	1.02	0	
ZS75K4E-TWE	575	3	16.1	100	1.7	0	
ZS92K4-TW7	380	3	22.9	195	0.57	0	
ZS92K4-TWC	208/230	3	40.7	350	0.22	0	
ZS92K4-TWD	460	3	20	158	0.83	0	
ZS92K4-TWE	575	3	15.4	125	1.28	0	
ZS92K4E-TW7	380	3	28.2	195	0.57	0	
ZS92K4E-TWC	208/230	3	52.9	350	0.22	0	
ZS92K4E-TWD	460	3	25	158	0.83	0	
ZS92K4E-TWE	575	3	20	125	1.28	0	
ZX15KC-TFD	460	3	4.3	27	7.1	0	
ZX15KCE-TFD	460	3	5	27	7.1	0	
ZX21KC-TFD	460	3	5.7	39	4.83	0	
ZX21KCE-TFD	460	3	6.1	39	4.83	0	
ZX30KC-TFD	460	3	7.4	47.5	3.65	0	
ZX30KCE-TFD	460	3	7.5	47.5	3.65	0	
ZX38KC-TFD	460	3	8.9	63	2.72	0	
ZX38KCE-TFD	460	3	9.6	63	2.72	0	
ZX45KC-TFD	460	3	11.5	70	2.27	0	
ZX45KCE-TFD	460	3	10.1	70	2.27	0	
ZX51KC-TFD	460	3	12.1	100	1.79	0	
ZX51KCE-TFD	460	3	11.8	100	1.79	0	

‡ † See Section F Introduction for more information.

FF80

**Electrical Data - Copeland Scroll®**

Model	Volts	PH	Max RLA	LRA	Winding Resistance		Run Cap PN ‡
					Start or Line/Line †	Run	
ZXI09KC-TFD	460	3	5.7	41			
ZXI09KCE-TFD	460	3	6	41			
ZXI18KC-TFD	460	3	11.1	70	2.26	0	
ZXI18KCE-TFD	460	3	11.1	70	2.26	0	

‡ † See Section F Introduction for more information.

FF81

### Electrical Data - Copeland Screw™

Model	Voltage	PH	Max RLA	LRA	Half Wdg.RLA	Half Wdg.LRA
SCA2-11HE-FWC	208/230	3	265	1807		1250
SCA2-11HE-FWD	460	3	132.9	814		563
SCA2-11HE-TWE	575	3	105.7	648		449
SCA2-12HE-FWC	208/230	3	325	2072		1434
SCA2-12HE-FWD	460	3	162.1	958		663
SCA2-12HE-TWE	575	3	130	766		530
SCA2-14HE-FWC	208/230	3	312.9	2336		1612
SCA2-14HE-FWD	460	3	175.7	1036		716
SCA2-14HE-TWE	575	3	140	835		577
SCA2-16HE-EWD	460	3	NA	1364		786
SCA2-16HE-EWE	575	3	NA	1091	224	628
SCA2-18HE-EWD	460	3	NA	1442		831
SCA2-18HE-EWE	575	3	NA	1153		664
SCA2-21HE-EWD	460	3	NA	1853		1068
SCA2-21HE-EWE	575	3	NA	1482		854
SCA2-24HE-EWD	460	3	NA	2029		1169
SCA2-24HE-EWE	575	3	NA	1623		935
SCA2-350E-FWC	208/230	3	90	535		286
SCA2-350E-FWD	460	3	44.9	254		136
SCA2-350E-TWE	575	3	35.9	203		108
SCA2-400E-FWC	208/230	3	120	737		394
SCA2-400E-FWD	460	3	60	329		176
SCA2-400E-TWE	575	3	48	263		141
SCA2-500E-FWC	208/230	3	165	743		466
SCA2-500E-FWD	460	3	82.1	359		226
SCA2-500E-TWE	575	3	66	296		186
SCA2-600E-FWC	208/230	3	179.3	939		559

FG1

### Electrical Data - Copeland Screw™

Model	Voltage	PH	Max RLA	LRA	Half Wdg.RLA	Half Wdg.LRA
SCA2-600E-FWD	460	3	89.3	449		267
SCA2-600E-TWE	575	3	71.4	357		212
SCA2-700E-FWC	208/230	3	192.1	1021		669
SCA2-700E-FWD	460	3	96.4	485		303
SCA2-700E-TWE	575	3	77.1	412		259
SCA2-800E-FWC	208/230	3	218.6	1416		966
SCA2-800E-FWD	460	3	109.3	632		433
SCA2-800E-TWE	575	3	87.9	505		346
SCA2-801E-FWC	208/230	3	202.9	1386		845
SCA2-801E-FWD	460	3	94.3	556		339
SCA2-801E-TWE	575	3	80	483		295
SCA2-900E-FWC	208/230	3	231.4	1522		1053
SCA2-900E-FWD	460	3	115.7	690		477
SCA2-900E-TWE	575	3	92.1	555		384
SCA2-901E-FWC	208/230	3	241.4	1506		918
SCA2-901E-FWD	460	3	112.9	703		426
SCA2-901E-TWE	575	3	96.4	603		367
SCH1-5000-FWC	208/230	3	153.6	743		431
SCH1-5000-FWD	460	3	74	355		206
SCH1-5000-TWE	575	3	59.3	281		180
SCH1-6000-FWC	208/230	3	198.6	939		559
SCH1-6000-FWD	460	3	95	449		267
SCH1-6000-TWE	575	3	75.7	322		208
SCH1-7000-FWC	208/230	3	200	1015		607
SCH1-7000-FWD	460	3	95.7	485		290
SCH1-7000-TWE	575	3	76.4	404		260
SCH1-8000-FWC	208/230	3	209.3	1224		732

FG2



### Electrical Data - Copeland Screw™

Model	Voltage	PH	Max RLA	LRA	Half Wdg.RLA	Half Wdg.LRA
SCH1-8000-FWD	460	3	100	585		350
SCH1-8000-TWE	575	3	80	433		279
SCH1-9000-FWC	208/230	3	243.6	1435		885
SCH1-9000-FWD	460	3	116.4	686		423
SCH1-9000-TWE	575	3	92.9	546		358
SCH2-11H0-FWC	208/230	3	284.3	1988		1375
SCH2-11H0-FWD	460	3	142.1	895		619
SCH2-11H0-TWE	575	3	113.6	713		494
SCH2-11HE-FWC	208/230	3	272.9	1988		1375
SCH2-11HE-FWD	460	3	136.4	895		619
SCH2-11HE-TWE	575	3	109.3	713		494
SCH2-12H0-FWC	208/230	3	317.1	2279		1577
SCH2-12H0-FWD	460	3	158.6	1054		729
SCH2-12H0-TWE	575	3	127.1	843		583
SCH2-12HE-FWC	208/230	3	302.1	2279		1577
SCH2-12HE-FWD	460	3	151.4	1054		729
SCH2-12HE-TWE	575	3	120.7	843		583
SCH2-14H0-FWC	208/230	3	359.3	2569		1773
SCH2-14H0-FWD	460	3	179.3	1139		788
SCH2-14H0-TWE	575	3	143.6	918		635
SCH2-14HE-FWC	208/230	3	330.7	2569		1773
SCH2-14HE-FWD	460	3	165.7	1139		788
SCH2-14HE-TWE	575	3	132.1	918		635
SCH2-18H0-EWD	460	3	NA	1546		515
SCH2-18H0-EWE	575	3	NA	1236		412
SCH2-18HE-EWD	460	3	NA	1546		515
SCH2-18HE-EWE	575	3	NA	1236		412

FG3

**Electrical Data - Copeland Screw™**

Model	Voltage	PH	Max RLA	LRA	Half Wdg.RLA	Half Wdg.LRA
SCH2-21H0-EWD	460	3	NA	1742		584
SCH2-21H0-EWE	575	3	NA	1393		467
SCH2-21HE-EWD	460	3	NA	1742		584
SCH2-21HE-EWE	575	3	NA	1393		467
SCH2-24H0-EWD	460	3	NA	2000		667
SCH2-24H0-EWE	575	3	NA	1600		534
SCH2-24HE-EWD	460	3	NA	2000		667
SCH2-24HE-EWE	575	3	NA	1600		534
SCH2-28H0-EWD	460	3	NA	2520		805
SCH2-28H0-EWE	575	3	NA	2016		644
SCH2-28HE-EWD	460	3	NA	2520		805
SCH2-28HE-EWE	575	3	NA	2016		644
SCH2-30H0-EWD	460	3	NA	2520		805
SCH2-30H0-EWE	575	3	NA	2016		644
SCH2-30HE-EWD	460	3	NA	2520		805
SCH2-30HE-EWE	575	3	NA	2016		644
SCH2-5000-FWC	208/230	3	115.7	939		498
SCH2-5000-FWD	460	3	57.9	411		218
SCH2-5000-TWE	575	3	46.4	329		174
SCH2-500E-FWC	208/230	3	137.1	939		498
SCH2-500E-FWD	460	3	68.6	411		218
SCH2-500E-TWE	575	3	55	329		174
SCH2-6000-FWC	208/230	3	164.3	1162		616
SCH2-6000-FWD	460	3	82.1	508		269
SCH2-6000-TWE	575	3	65.7	406		215
SCH2-600E-FWC	208/230	3	164.3	1162		616
SCH2-600E-FWD	460	3	82.1	508		269

FG4

### Electrical Data - Copeland Screw™

Model	Voltage	PH	Max RLA	LRA	Half Wdg.RLA	Half Wdg.LRA
SCH2-600E-TWE	575	3	65.7	406		215
SCH2-7000-FWC	208/230	3	200	1015	125.5	607
SCH2-7000-FWD	460	3	95.7	485	60	290
SCH2-7000-TWE	575	3	76.4	404		260
SCH2-700E-FWC	208/230	3	188.6	1015	125.5	607
SCH2-700E-FWD	460	3	90.7	485	60	290
SCH2-700E-TWE	575	3	72.9	404	48	260
SCH2-8000-FWC	208/230	3	209.3	1224	131.5	732
SCH2-8000-FWD	460	3	100	585	63	350
SCH2-8000-TWE	575	3	80	433		279
SCH2-800E-FWC	208/230	3	225.7	1224	131.5	732
SCH2-800E-FWD	460	3	108.6	585	63	350
SCH2-800E-TWE	575	3	87.1	433	50.5	279
SCH2-9000-FWC	208/230	3	243.6	1435	152.5	885
SCH2-9000-FWD	460	3	116.4	686	73	423
SCH2-9000-TWE	575	3	92.9	546		358
SCH2-900E-FWC	208/230	3	250.7	1435	152.5	885
SCH2-900E-FWD	460	3	120.7	686	73	423
SCH2-900E-TWE	575	3	97.1	546	58	358
SHL1-12H0-FWC	208/230	3	NA	943		612
SHL1-12H0-FWD	460	3	NA	943		612
SHL1-12H0-TWE	575	3	NA	943		612
SHL1-2000-TWE	575	3	32.9	183		127
SHL1-2000-TWK	208/230	3	81.4	492	40.5	164
SHL1-2000-TWK	460	3	40.7	246		
SHL1-2500-TWE	575	3	34.3	166		94
SHL1-2500-TWK	208/230	3	85.7	436	42.5	150

FG5

### Electrical Data - Copeland Screw™

Model	Voltage	PH	Max RLA	LRA	Half Wdg.RLA	Half Wdg.LRA
SHL1-2500-TWK	460	3	42.9	218		
SHL1-3000-TWE	575	3	41.4	204		131
SHL1-3000-TWK	208/230	3	84.3	532	52	184
SHL1-3000-TWK	460	3	52.1	266		
SHL1-4000-FWC	208/230	3	162.9	655		391
SHL1-4000-FWD	460	3	77.9	313		187
SHL1-4000-TWE	575	3	62.1	222		147
SHL1-5000-FWC	208/230	3	171.4	743		431
SHL1-5000-FWD	460	3	82.1	355		206
SHL1-5000-TWE	575	3	70.7	281		180
SHL1-6000-FWC	208/230	3	176.4	939		559
SHL1-6000-FWD	460	3	91.4	449		267
SHL1-6000-TWE	575	3	84.3	322		208
SHL1-7000-FWC	208/230	3	213.6	1015		607
SHL1-7000-FWD	460	3	82.9	485		290
SHL1-7000-TWE	575	3	80.7	404		260
SHL1-7500-FWC	208/230	3	224.3	1224		732
SHL1-7500-FWD	460	3	95	585		350
SHL1-7500-TWE	575	3	85.7	433		279
SHL2-2000-TWE	575	3	32.9	183		127
SHL2-2000-TWK	208/230	3	81.4	492	40.5	164
SHL2-2000-TWK	460	3	40.7	246		
SHL2-2500-FWD	460	3	42.9	218		
SHL2-2500-TWE	575	3	34.3	166		94
SHL2-2500-TWK	208/230	3	85.7	436	42.5	150
SHL2-2500-TWK	460	3	42.9	218		
SHL2-3000-TWE	575	3	41.4	204		131

FG6

### Electrical Data - Copeland Screw™

Model	Voltage	PH	Max RLA	LRA	Half Wdg.RLA	Half Wdg.LRA
SHL2-3000-TWK	208/230	3	84.3	532	52	184
SHL2-3000-TWK	460	3	52.1	266		
SHM1-11H0-FWC	208/230	3	NA	801		520
SHM1-11H0-FWD	460	3	NA	801		520
SHM1-11H0-TWE	575	3	NA	801		520
SHM1-12H0-FWC	208/230	3	NA	943		612
SHM1-12H0-FWD	460	3	NA	943		612
SHM1-12H0-TWE	575	3	NA	943		612
SHM1-14H0-FWC	208/230	3	NA	1023		665
SHM1-14H0-FWD	460	3	NA	1023		665
SHM1-14H0-TWE	575	3	NA	1023		665
SHM1-3000-TWE	575	3	37.1	166		94
SHM1-3000-TWK	208/230	3	92.9	436	46	150
SHM1-3000-TWK	460	3	46.4	218		
SHM1-3500-TWE	575	3	48.6	204		131
SHM1-3500-TWK	208/230	3	98.6	532	60	184
SHM1-3500-TWK	460	3	60.7	266		
SHM1-4000-TWE	575	3	52.1	255		166
SHM1-4000-TWK	208/230	3	130	622	65	218
SHM1-4000-TWK	460	3	65	311		
SHM1-5000-FWC	208/230	3	184.3	743		431
SHM1-5000-FWD	460	3	88.6	355		206
SHM1-5000-TWE	575	3	70.7	281		180
SHM1-6000-FWC	208/230	3	238.6	939		559
SHM1-6000-FWD	460	3	95	449		267
SHM1-6000-TWE	575	3	91.4	322		208
SHM1-7000-FWC	208/230	3	210.7	1015		607

FG7

**Electrical Data - Copeland Screw™**

Model	Voltage	PH	Max RLA	LRA	Half Wdg.RLA	Half Wdg.LRA
SHM1-7000-FWD	460	3	95.7	485		290
SHM1-7000-TWE	575	3	80.7	404		260
SHM1-8000-FWC	208/230	3	245	1224		732
SHM1-8000-FWD	460	3	117.1	585		350
SHM1-8000-TWE	575	3	93.6	433		279
SHM1-9000-FWC	208/230	3	255.7	1435		885
SHM1-9000-FWD	460	3	122.1	686		423
SHM1-9000-TWE	575	3	97.9	546		358
SHM2-3000-TWE	575	3	37.1	166		94
SHM2-3000-TWK	208/230	3	92.9	436	46	150
SHM2-3000-TWK	460	3	46.4	218		
SHM2-3500-TWE	575	3	48.6	204		131
SHM2-3500-TWK	208/230	3	98.6	532	60	184
SHM2-3500-TWK	460	3	60.7	266		
SHM2-4000-TWE	575	3	52.1	255		166
SHM2-4000-TWK	208/230	3	130	622	65	218
SHM2-4000-TWK	460	3	65	311		
SHMS-4000-FWD	460	3	88.6	313		187

FG8

## SECTION G

### WIRING DIAGRAMS

The wiring diagram guide lists compressors by model designation. These are indexed against an Electrical Characteristics code. (The third group of numbers in the model number.) The third letter of third group of the model number may be missing. It may be any one of a number of letters representing electrical characteristics.

These diagrams represent typical wiring connections for the compressors listed but may not be identical to the diagram in the compressor terminal box.

Discontinued wiring diagrams listed in the back of this section are for compressors that are no longer available by Emerson Climate Technologies, Inc. The replacement wiring diagram is not necessarily the same as the old wiring diagram show in the front of this section. Use caution when selecting the appropriate wiring diagram.

This section contains current information on Copeland® brand products. Information on obsolete models can be obtained from your local Emerson Climate Technologies wholesaler.

## WELDED COMPRESSORS DIAGRAMS

MODEL	TF*	ES8	TS*	(2) PF*	CSV
<b>CR , CS</b>	(5) 0770 (1,5) 005-1211-01			(1,5) 005-1211 (5) 0782 (1,3) 005-1210 (1,3) 005-1212	
<b>CT</b>			1319		1318
<b>R</b>	0833 0778/0779			0865 (1) 005-0670 0768	

MODEL	IA*	SAA	CA*	(2) PA*	CF*	TF*
<b>R</b>	0831/0832 0776/0777 0780 0769		0767 0818/0819 0820	0774/0775 0834 0781		
<b>A-LINE</b>	0929 1223	0930	0932	0932	0931	0980

- (1) DIAGRAM MOLDED IN COMPRESSOR TERMINAL BOX.
- (2) MAY REQUIRE PTC THERMISTOR
- (3) 59 FRAME
- (4) 70 FRAME
- (5) 63 FRAME
- (6) 4 PIN SENSOR CONNECTION

NOTE: ASTERISK AFTER FIRST TWO LETTERS INDICATES MAY BE ANY LETTER DEPENDING ON ELECTRICAL CHARACTERISTICS.



## SCROLL DIAGRAMS

MODEL	TF*	(2) PF*	TW*
ZB30-45K, ZF13-18K, ZS30-45K, ZMD18K, ZBD30-45K, ZBH30-45K (REFR) ZR46-81K, ZRD49-72K, ZP54-57K (AC)	(3) 0880	(1,3) 005-1213	
ZF6-11K, ZS15-26K, ZB15-26K, ZBH21K (REFR) ZR28-48K, ZP32-44K (AC)	(1,4,5) 005-1270	(1,4,5) 005-1270	
ZB50-88K (REFR) ZR84-144K (AC)	(1) 005-1271		
ZC40,60C CRYO	(3) 0880	(1,3) 005-1213	
ZR90K, ZR11-19M ZP180K (AC)			1201
ZF24-48K, ZB,ZS56-92K, ZB,ZS11M (REFR)			0906
ZB10-14K, ZBH11-14K (REFR) ZR16-24K, ZP16-23K (AC)	(1,4,5)005-1270	(1,4,5) 005-1270	
ZP235- ZP295K, ZR250,300K, ZR310,380K Large Commercial Scroll (LCS)			0953
ZR22 - ZR 61, ZF09 - 11, ZX21, ZS21-26, VR61	1199		

- (1) DIAGRAM MOLDED IN COMPRESSOR TERMINAL BOX.
- (2) MAY REQUIRE PTC THERMISTOR
- (3) 70 FRAME
- (4) 63 FRAME
- (5) FOR PROPER WIRING SEE SYSTEM WIRING DIAGRAM

NOTE: ASTERISK AFTER FIRST TWO LETTERS INDICATES MAY BE ANY LETTER DEPENDING ON ELECTRICAL CHARACTERISTICS.

## COPELAMETIC DIAGRAMS

MODEL	TF*	ES*	ESM	TS*
<b>M</b>	0803		(6) 0900	
<b>N</b>	0803			
<b>2D</b>	0803	(5,6) 0897		
<b>3D</b>	0803, 0816 (4) 0840 0837	(5,6) 0897		
<b>4</b>		(5,6) 0897	(6) 0900	(6) 2169 (7) 1851
<b>6</b>		(5,6) 0897	(6) 0900	(6) 2169
<b>8</b>				(6) 2169
<b>9</b>	0803 0837	(5,6) 0897	(6) 0900	

MODEL	XAA	IA*	SAA	CAF/CAG
<b>H</b>	0809	0809	0809	(3) 0822
<b>K</b>	0809	0809		(3) 0822

- (1) SIX LEAD MOTOR
- (2) THREE LEAD MOTOR
- (3) 50 HERTZ APPLICATIONS
- (4) VDE GROUNDING
- (5) SMALLER VERSION OF 0899
- (6) DUAL VOLTAGE MODULE
- (7) 24 VOLT MODULE

NOTE: ASTERISK AFTER FIRST TWO LETTERS INDICATES MAY BE ANY LETTER DEPENDING ON ELECTRICAL CHARACTERISTICS.

## COPELAMETIC DIAGRAMS

MODEL	CA*	CFB	(1) FS* (1) TSE (1) TSU	TA*	(2)TSE (2) TS7 (2)TSU (2) TSC
<b>E</b>	0807 0821			0806	
<b>H</b>	0807			0810	
<b>K</b>	0807			0810	
<b>L</b>	0802			0805	
<b>M</b>		0804	(6) 2170 (5,6) 0914		
<b>N</b>		0804			
<b>2D</b>		0804	(6) 2170		
<b>3</b>	0807			0806	
<b>3D</b>			(6) 2170		
<b>4</b>			(6) 2170 (6) 0902 (7)1852		(6) 2167
<b>6</b>			(6) 2170 (6) 0902		(6) 2167
<b>8</b>			(6) 2170		(6) 2167
<b>9</b>		0804	(6) 2170		(6) 2167

- (1) SIX LEAD MOTOR
- (2) THREE LEAD MOTOR
- (3) 50 HERTZ APPLICATIONS
- (4) VDE GROUNDING
- (5) SMALLER VERSION OF 0899
- (6) DUAL VOLTAGE MODULE
- (7) 24 VOLT MODULE

NOTE: ASTERISK AFTER FIRST TWO LETTERS INDICATES MAY BE ANY LETTER DEPENDING ON ELECTRICAL CHARACTERISTICS.

The following tables lists discontinued wiring diagrams and their replacements.

<b>MODEL</b>	<b>VOLTAGE</b>	<b>OLD DIAGRAM</b>	<b>NEW DIAGRAM</b>
JR	IFA	0784	No Replacement
J,XH	IA*	005-0655 005-0697	No Replacement
J,XH	SAA	0813	No Replacement
J,XH	CA*	0820	No Replacement
J,XH	PA*	0781	No Replacement
BR/QR	ES*	0758	0875
BR/QR	TS*	0716	0875
BR/QR	EW8	0825	0875 (ES8)
BR/QR	TS*	0874	0948
BR/QR	ES8	0875	0949
BR/QR	TF*	005-0492	005-0922
BR/QR	TF*	005-0637	005-0922
BR/QR	ES*	0815	0875
BR/QR	TF*	005-0922	005-1043
BR/QR	TF*	005-1043	No Replacement
BR/QR	ES8	0883	No Replacement
BR/QR	TS*	0882	No Replacement
BR/QR	TS*	0948	No Replacement
CR	ES*	0757	0875
CR	EW8	0825	0875
CR	ES*	0876	0875
CR	EW8	0823	No Replacement
CR	ES*	0811	0875

<b>MODEL</b>	<b>VOLTAGE</b>	<b>OLD DIAGRAM</b>	<b>NEW DIAGRAM</b>
<b>CR</b>	EW8	0824	0875
<b>CR, CS</b>	ES*	0801	No Replacement
<b>CT</b>	CSV	0751	0884
<b>CT</b>	TS*	0752	0885
<b>CR 63FR</b>	PF*	005-0678	005-0799
<b>CR</b>	PF*	005-0679	005-0799
<b>CV</b>	TF*	0770	No Replacement
<b>CR</b>	ES8	0875	0917
<b>CT</b>	CSV	0884	0918
<b>CT</b>	TS*	0885	0919
<b>CR</b>	ES8	0917	0949
<b>CT</b>	TS*	0919	1319
<b>CT</b>	CSV	0918	1318
<b>ZF,ZS,ZB, ZR,ZP,ZB</b>	TF*	0826	0880
<b>ASPEN</b>	PF*	005-0838	No Replacement
<b>ASPEN</b>	TF*	1196	No Replacement
<b>ASPEN</b>	PF*	005-0706	No Replacement
<b>ZF,ZS,ZB</b>	PF*	005-0788	005-0837
<b>ZF,ZS,ZB</b>	PF*	005-0777	005-0819
<b>ZF,ZS,ZB</b>	PF*	005-0819	005-0840
<b>ASPEN</b>	PF*	0756	No Replacement
<b>ZB</b>	PF*	005-0788	005-0837
<b>ZB</b>	PF*	005-0837	005-0860
<b>ZB,ZF</b>	PF*	005-0777	005-0819
<b>ZB,ZF,ZS</b>	PF*	005-0819	005-0840
<b>ZR (AC)</b>	TW*	1825	1201

<b>MODEL</b>	<b>VOLTAGE</b>	<b>OLD DIAGRAM</b>	<b>NEW DIAGRAM</b>
<b>ZF,ZS,ZB (REFR)</b>	TW*	1825	0906
<b>ZB</b>	PF*	005-0840	005-1062
<b>ZB,ZR</b>	TF*	005-0868	005-0922
<b>ZB,ZR</b>	TF*	005-0922	005-1043
<b>ZB, ZS, ZF, ZRD, ZP</b>	PF*	005-0860	005-1071
<b>9</b>	THC,TLC	0748	0853 (TSC)
<b>9</b>	THC,TLC	0748	0803 (TFC)
<b>9</b>	THD,TLD	0748	0803 (TFD)
<b>9</b>	THE,TLE	0748	0803 (TFE)
<b>9</b>	FS*	0856	0899, See note 2
<b>9</b>	ESM	0858	0900, See note 2
<b>9</b>	TS*	0853	0896, See note 2
<b>9</b>	TSE,TSU,TSC,TS7	0896	2167
<b>9</b>	FS*,TSE,TSU	0899	2170
<b>4/6</b>	TSE	0759	No Replacement
<b>4/6</b>	FS*,TSE, TSU	0841	0857
<b>4/6</b>	TSE,TSU, TS7	0760	0853, See note 1
<b>4/6</b>	ES*	0762	0854, See note 1
<b>4/6</b>	ESM	0848	0858, See note 1
<b>4/6,8</b>	TS*	0763	0855, See note 1
<b>4/6,8</b>	FS*	0765	0856, See note 1

<b>MODEL</b>	<b>VOLTAGE</b>	<b>OLD DIAGRAM</b>	<b>NEW DIAGRAM</b>
<b>4/6,8</b>	TS*	0898	2169
<b>4/6,8</b>	TSE,TSU,TSC,TS7	0896	2167
<b>4/6,8</b>	FS*,TSE,TSU	0899	2170
<b>4/6</b>	TSE/TSU	0765	0856, See note 1
<b>4DK6, 4DS6</b>	FSD	0902	1299, See note 2
<b>4DK6, 4DS6</b>	FSD	1299	2177, See note 2
<b>4,6</b>	FS*	0857	0902, See note 2
<b>4,6</b>	TSE	0853	0896, See note 2
<b>4,6</b>	TS*	0855	0898, See note 2
<b>4,6</b>	ESM	0858	0900, See note 2
<b>8</b>	TS*	0855	0898, See note 2
<b>8</b>	TS7	0853	0896, See note 2
<b>M</b>	FSC	0849	0859, See Note 1
<b>M</b>	FS*	0856	0899, See note 2
<b>M</b>	FS*	0859	0914, See note 2
<b>M</b>	ES*	0854	0897, See note 2
<b>2D</b>	FS*	0856	0899, See note 2
<b>2D</b>	ES*	0854	0897, See note 2
<b>3D</b>	ES*	0854	0897, See note 2

Notes:

1. Models replaced with dual voltage 31aa module.  
(Requires a jumper wire from L2 to LO for 120V and L2 to HI for 240V)
2. Models replaced with dual voltage 41aa module.  
(Jumper wire not required)

USE COPPER CONDUCTORS ONLY.  
 USE THIS EQUIPMENT ON A  
 GROUNDED SYSTEM ONLY.  
 USE MINIMUM 60 °C WIRE FOR  
 AMPACITY DETERMINATION.  
 INTERNAL MOTOR PROTECTION-  
 ALLOW TIME FOR RESET.  
 CRANKCASE HEATER, WHEN  
 APPLIED, MUST BE CONNECTED  
 ONLY TO ITS RATED VOLTAGE.  
 OVERCURRENT PROTECTION  
 DEVICE RATING AND TYPE MUST  
 BE IN ACCORDANCE WITH  
 REGULATORY AGENCY END  
 PRODUCT APPROVALS-SEE  
 SYSTEM NAMEPLATE.

2-92

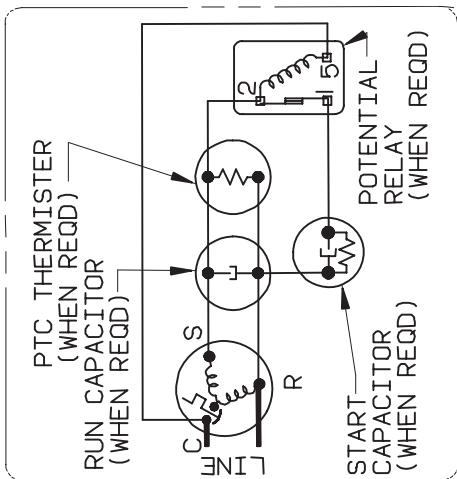

**Wiring Diagram 005-0670**



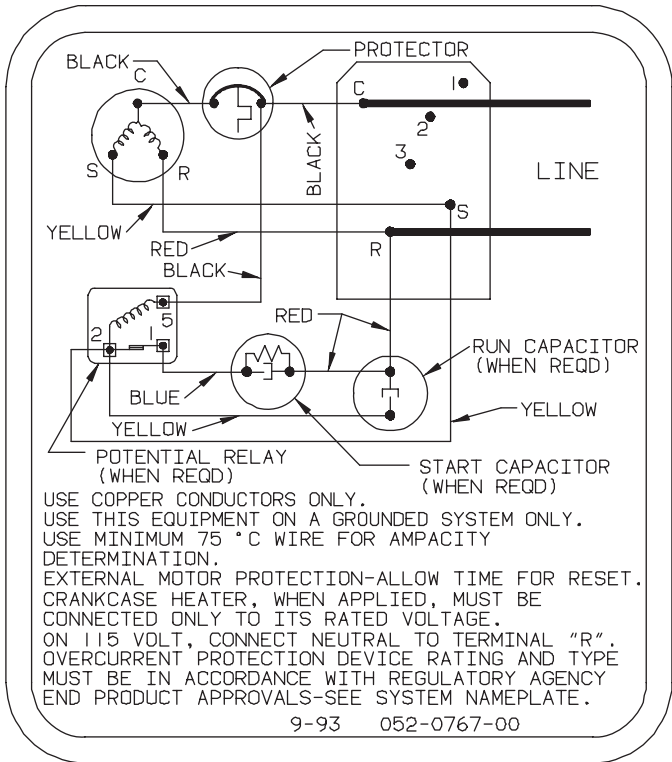

**Wiring Diagram 0767**

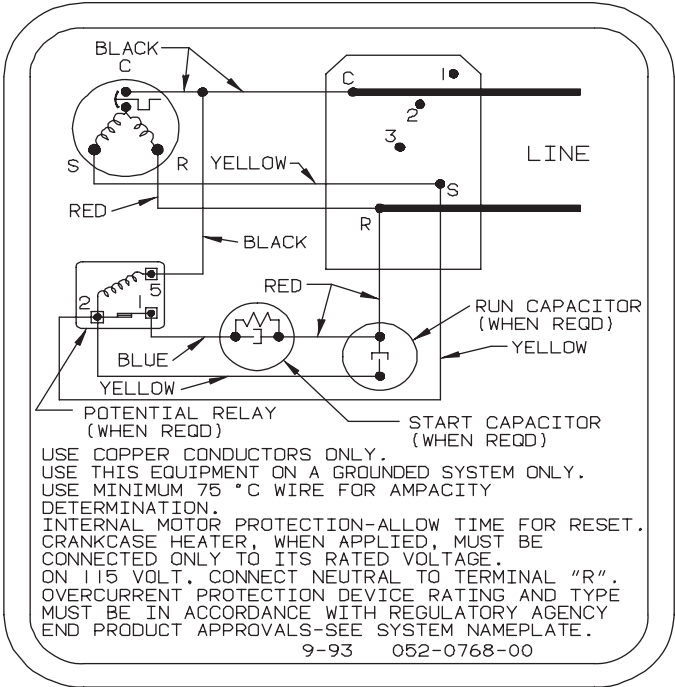

**Wiring Diagram 0768**

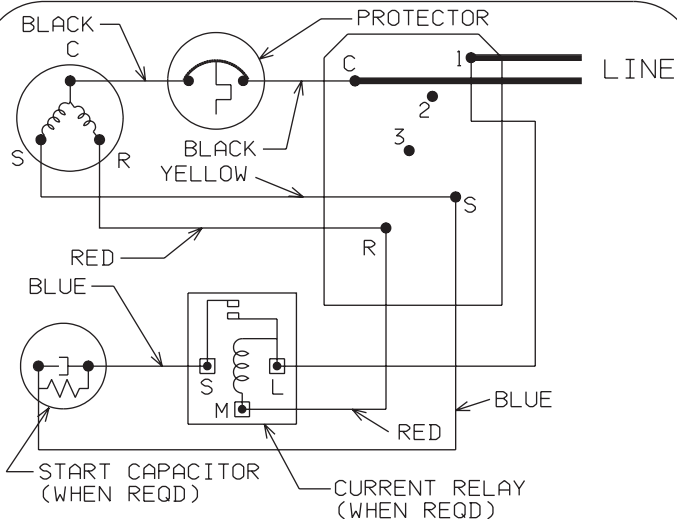

USE COPPER CONDUCTORS ONLY.  
 USE THIS EQUIPMENT ON A GROUNDED SYSTEM ONLY.  
 USE MINIMUM 75 °C WIRE FOR AMPACITY DETERMINATION.  
 EXTERNAL MOTOR PROTECTION-ALLOW TIME FOR RESET.  
 CRANKCASE HEATER, WHEN APPLIED, MUST BE CONNECTED ONLY TO ITS RATED VOLTAGE.  
 ON 115 VOLT, CONNECT NEUTRAL TO TERMINAL "1".  
 OVERCURRENT PROTECTION DEVICE RATING AND TYPE MUST BE IN ACCORDANCE WITH REGULATORY AGENCY END PRODUCT APPROVALS-SEE SYSTEM NAMEPLATE.

9-93 052-0769-00

**Wiring Diagram 0769**

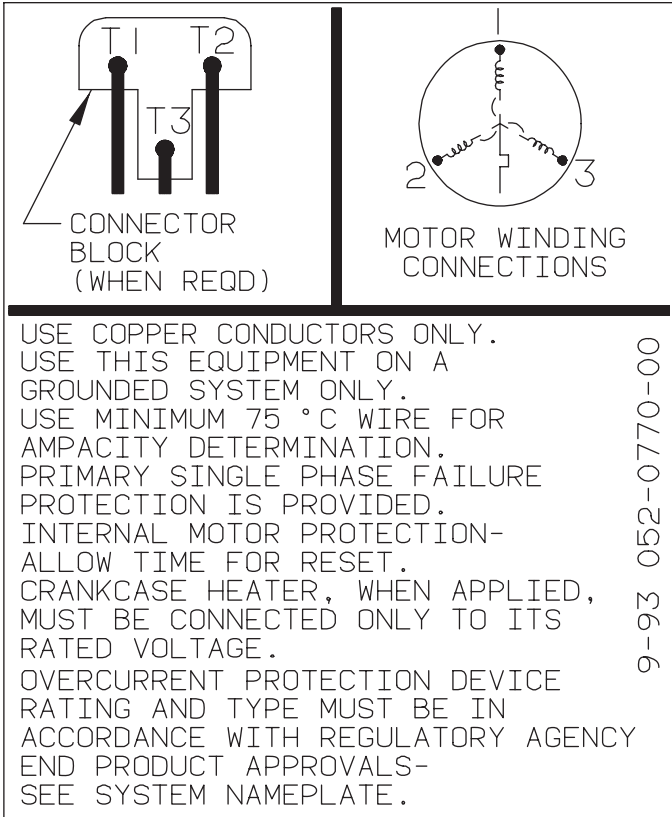

**Wiring Diagram 0770**

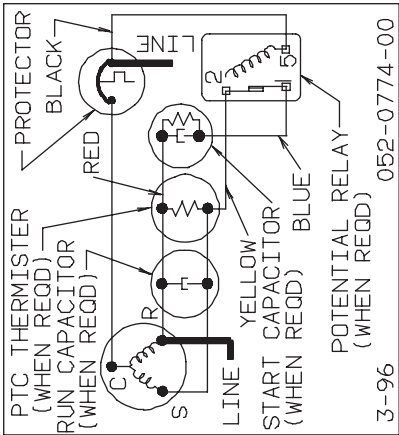

3-96

052-0774-00

USE COPPER CONDUCTORS ONLY.  
 USE THIS EQUIPMENT ON A GROUNDING SYSTEM ONLY.  
 USE MINIMUM 75 °C WIRE FOR AMPACITY DETERMINATION.  
 EXTERNAL MOTOR PROTECTION-ALLOW TIME FOR RESET.  
 CRANKCASE HEATER, WHEN APPLIED, MUST BE CONNECTED ONLY TO ITS RATED VOLTAGE.  
 ON 115 VOLT, CONNECT NEUTRAL TO TERMINAL "R".  
 OVERCURRENT PROTECTION DEVICE RATING AND TYPE MUST BE IN ACCORDANCE WITH REGULATORY AGENCY END PRODUCT APPROVALS-SEE SYSTEM NAMEPLATE.

9-93 052-0775-00

**Wiring Diagram 0774/0775**

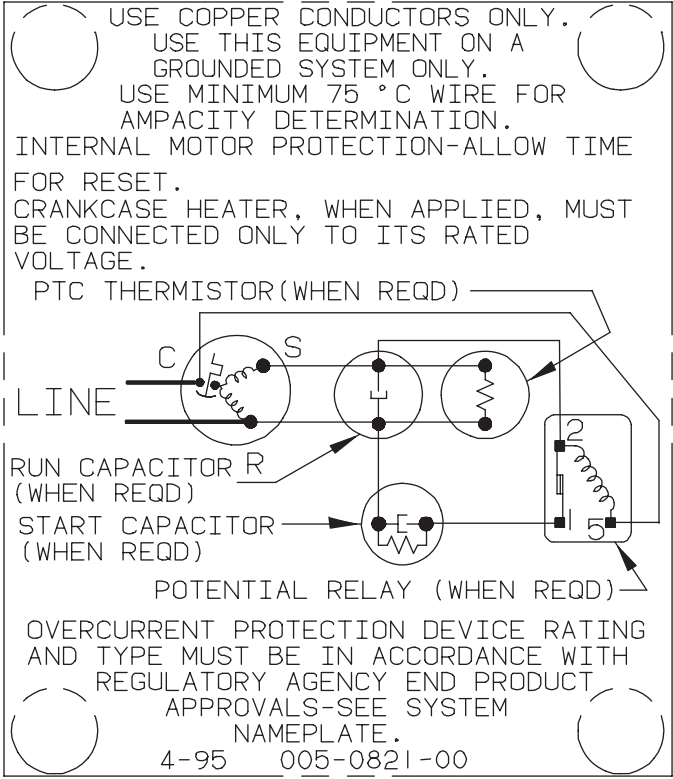

**Wiring Diagram 005-0776, 005-0821**

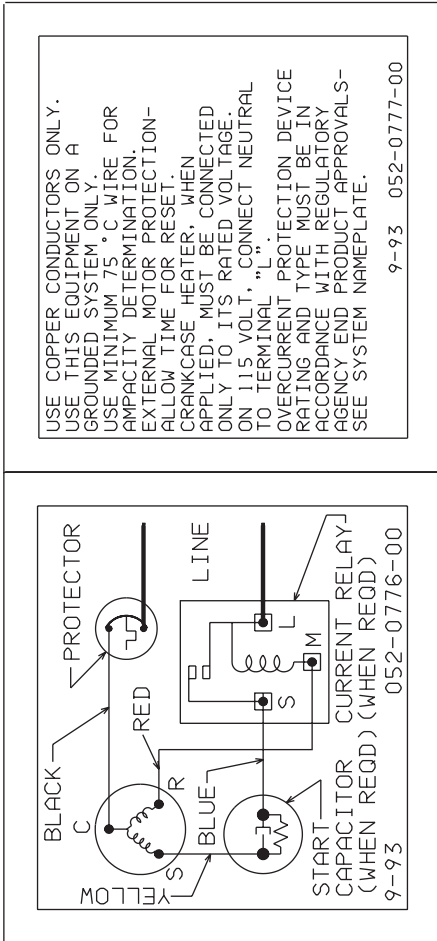

USE COPPER CONDUCTORS ONLY.  
 USE THIS EQUIPMENT ON A  
 GROUNDED SYSTEM ONLY.  
 USE MINIMUM 75 °C WIRE FOR  
 AMPACITY DETERMINATION.  
 EXTERNAL MOTOR PROTECTION-  
 ALLOW TIME FOR RESET.  
 CRANKCASE HEATER, WHEN  
 APPLIED, MUST BE CONNECTED  
 ONLY TO ITS RATED VOLTAGE.  
 ON 115 VOLT, "L", CONNECT NEUTRAL  
 TO TERMINAL "L".  
 OVERCURRENT PROTECTION DEVICE  
 RATING AND TYPE MUST BE IN  
 ACCORDANCE WITH REGULATORY  
 AGENCY END PRODUCT APPROVALS-  
 SEE SYSTEM NAMEPLATE.

9-93 052-0777-00

**Wiring Diagram 0776/0777**

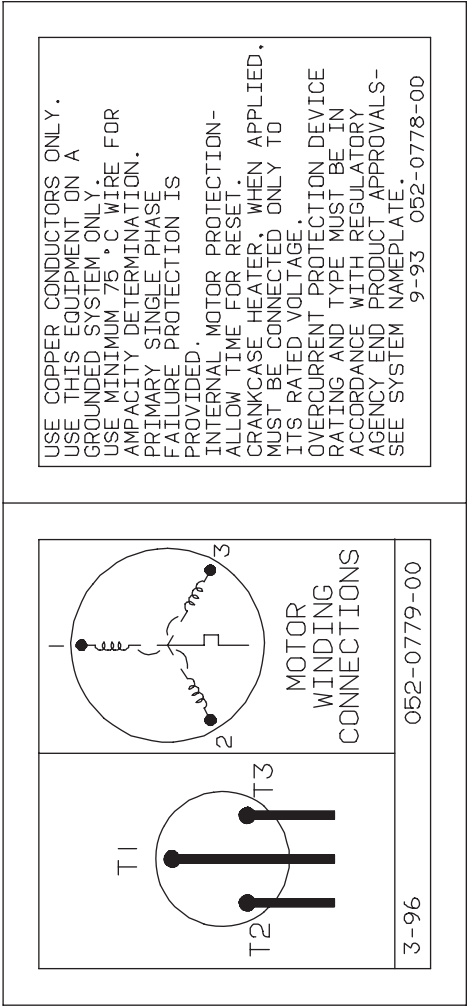

**Wiring Diagram 0778/0779**



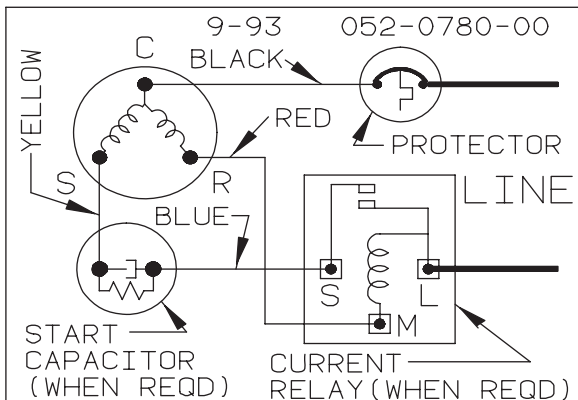

USE COPPER CONDUCTORS ONLY.  
 USE THIS EQUIPMENT ON A  
 GROUNDED SYSTEM ONLY.  
 USE MINIMUM 75 °C WIRE FOR  
 AMPACITY DETERMINATION.  
 EXTERNAL MOTOR PROTECTION-  
 ALLOW TIME FOR RESET.  
 CRANKCASE HEATER, WHEN  
 APPLIED, MUST BE CONNECTED  
 ONLY TO ITS RATED VOLTAGE.  
 ON 115 VOLT, CONNECT NEUTRAL  
 TO TERMINAL "L".  
 OVERCURRENT PROTECTION DEVICE  
 RATING AND TYPE MUST BE IN  
 ACCORDANCE WITH REGULATORY  
 AGENCY END PRODUCT APPROVALS-  
 SEE SYSTEM NAMEPLATE.

**Wiring Diagram 0780**

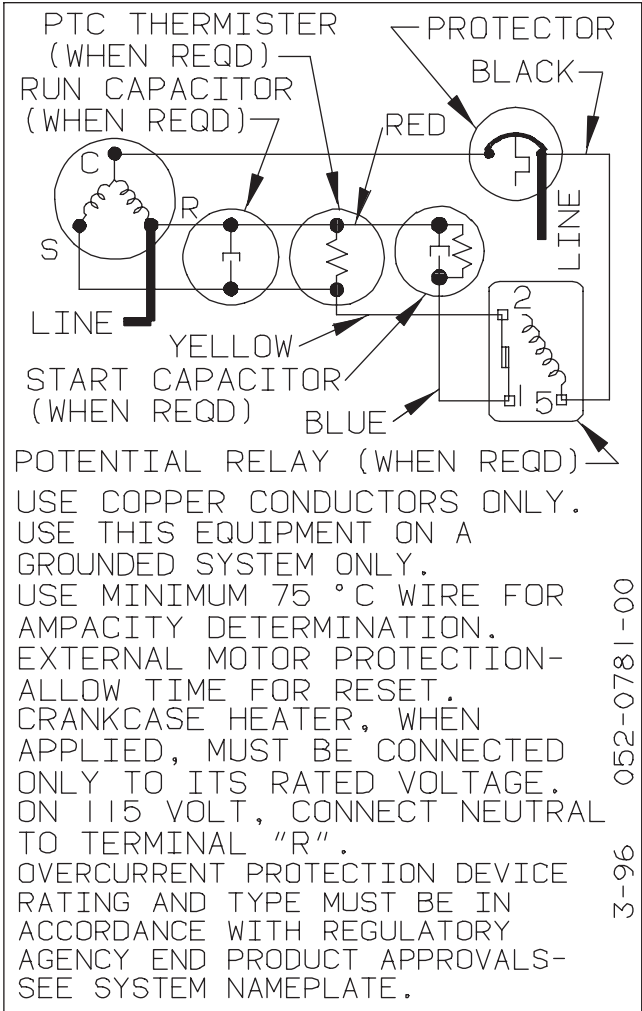

052-0781-00  
3-96

**Wiring Diagram 0781**

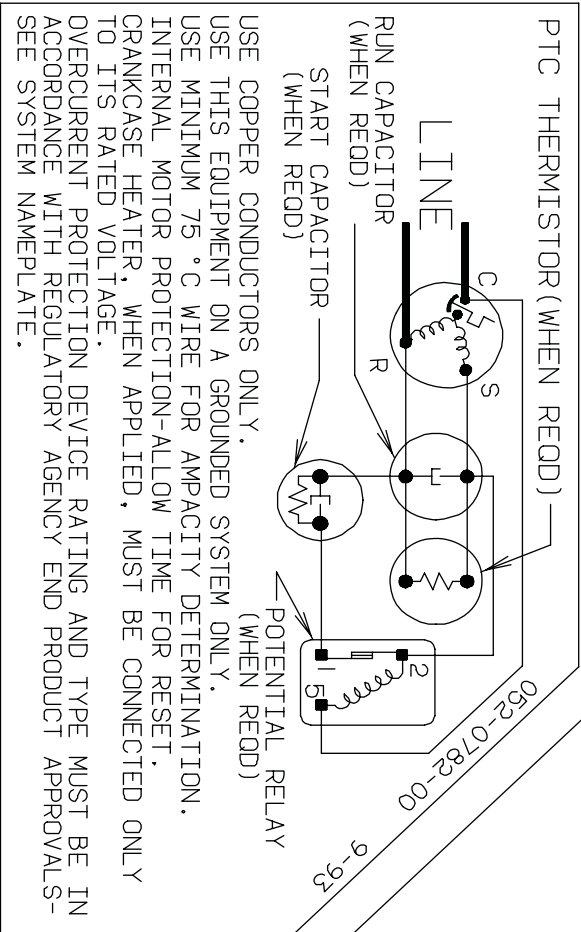

USE COPPER CONDUCTORS ONLY.

USE THIS EQUIPMENT ON A GROUNDED SYSTEM ONLY.

USE MINIMUM 75 °C WIRE FOR AMPACITY DETERMINATION.

INTERNAL MOTOR PROTECTION-ALLOW TIME FOR RESET.

CRANKCASE HEATER, WHEN APPLIED, MUST BE CONNECTED ONLY TO ITS RATED VOLTAGE.

OVERCURRENT PROTECTION DEVICE RATING AND TYPE MUST BE IN ACCORDANCE WITH REGULATORY AGENCY END PRODUCT APPROVALS-SEE SYSTEM NAMEPLATE.

**Wiring Diagram 0782**

USE COPPER CONDUCTORS ONLY.  
 USE THIS EQUIPMENT ON A GROUNDED SYSTEM ONLY.  
 USE MINIMUM 75 °C WIRE FOR AMPACITY DETERMINATION.  
 EXTERNAL MOTOR PROTECTION-ALLOW TIME FOR RESET.  
 CRANKCASE HEATER, WHEN APPLIED, MUST BE CONNECTED ONLY  
 TO ITS RATED VOLTAGE.  
 OVERCURRENT PROTECTION DEVICE RATING AND TYPE MUST BE IN  
 ACCORDANCE WITH REGULATORY AGENCY END PRODUCT APPROVALS-  
 SEE SYSTEM NAMEPLATE.

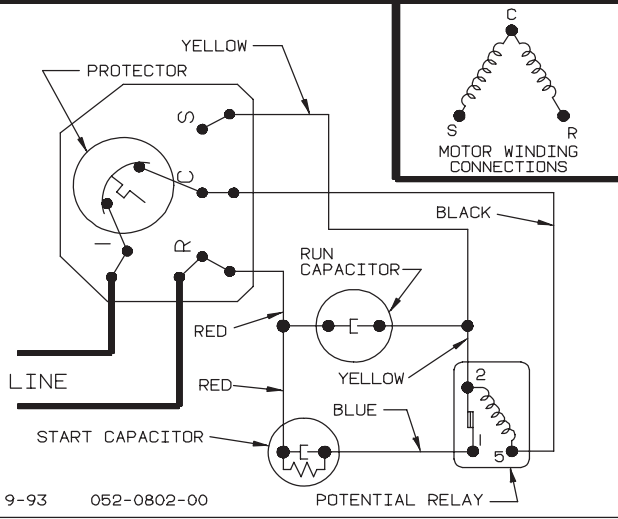

**Wiring Diagram 0802**

USE COPPER CONDUCTORS ONLY.  
USE THIS EQUIPMENT ON A GROUNDING SYSTEM ONLY.  
USE MINIMUM 75 °C WIRE FOR AMPACITY DETERMINATION.  
PRIMARY SINGLE PHASE FAILURE PROTECTION IS PROVIDED.  
INTERNAL MOTOR PROTECTION-ALLOW TIME FOR RESET.  
CRANKCASE HEATER, WHEN APPLIED, MUST BE CONNECTED ONLY TO ITS RATED VOLTAGE.  
OVERCURRENT PROTECTION DEVICE RATING AND TYPE MUST BE IN ACCORDANCE WITH REGULATORY AGENCY END PRODUCT APPROVALS-SEE SYSTEM NAMEPLATE.

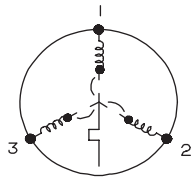

MOTOR WINDING CONNECTIONS

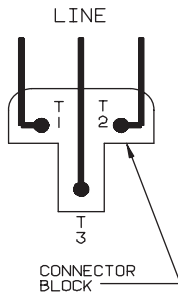

9-93 052-0803-00

### Wiring Diagram 0803

USE COPPER CONDUCTORS ONLY.  
 USE THIS EQUIPMENT ON A GROUND SYSTEM ONLY.  
 USE MINIMUM 75 °C WIRE FOR AMPACITY DETERMINATION.  
 INTERNAL MOTOR PROTECTION-ALLOW TIME FOR RESET.  
 CRANKCASE HEATER, WHEN APPLIED, MUST BE CONNECTED ONLY TO ITS RATED VOLTAGE.  
 OVERCURRENT PROTECTION DEVICE RATING AND TYPE MUST BE IN ACCORDANCE WITH REGULATORY AGENCY END PRODUCT APPROVALS-SEE SYSTEM NAMEPLATE.

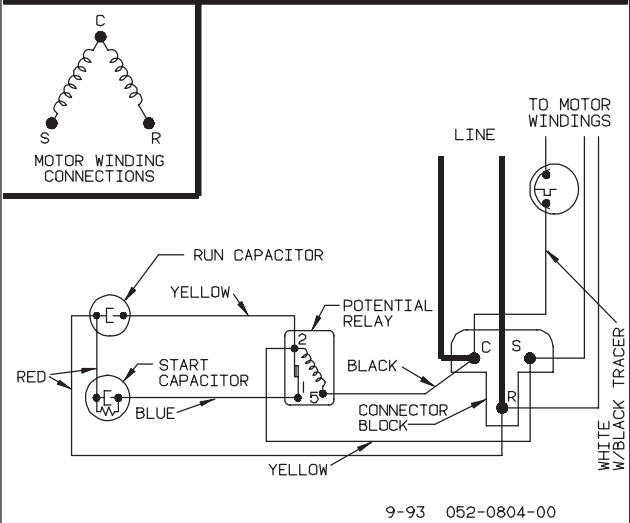

**Wiring Diagram 0804**

USE COPPER CONDUCTORS ONLY.  
 USE THIS EQUIPMENT ON A GROUNDING SYSTEM ONLY.  
 USE MINIMUM 75 °C WIRE FOR AMPACITY DETERMINATION.  
 PRIMARY SINGLE PHASE FAILURE PROTECTION IS PROVIDED.  
 EXTERNAL MOTOR PROTECTION-ALLOW TIME FOR RESET.  
 CRANKCASE HEATER, WHEN APPLIED, MUST BE CONNECTED ONLY TO ITS RATED VOLTAGE.  
 OVERCURRENT PROTECTION DEVICE RATING AND TYPE MUST BE IN ACCORDANCE WITH  
 REGULATORY AGENCY END PRODUCT APPROVALS-SEE SYSTEM NAMEPLATE.

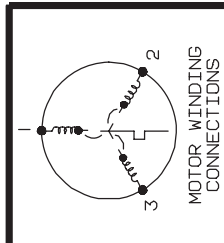
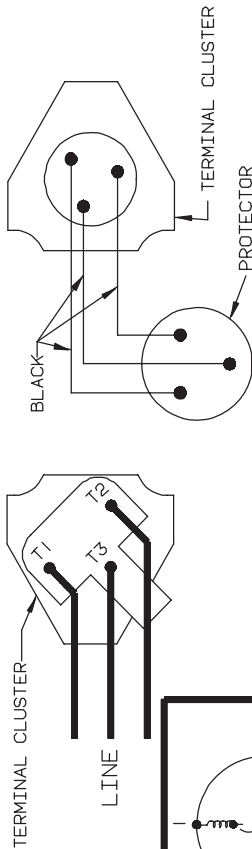

9-93 052-0805-00

Wiring Diagram 0805

USE COPPER CONDUCTORS ONLY.  
 USE THIS EQUIPMENT ON A GROUNDING SYSTEM ONLY.  
 USE MINIMUM 75 °C WIRE FOR AMPACITY DETERMINATION.  
 EXTERNAL MOTOR PROTECTION-ALLOW TIME FOR RESET.  
 PRIMARY SINGLE PHASE FAILURE PROTECTION IS PROVIDED.  
 CRANKCASE HEATER, WHEN APPLIED, MUST BE CONNECTED ONLY TO ITS RATED VOLTAGE.  
 OVERCURRENT PROTECTION DEVICE RATING AND TYPE MUST BE IN ACCORDANCE WITH  
 REGULATORY AGENCY END PRODUCT APPROVALS-SEE SYSTEM NAMEPLATE.

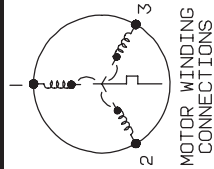
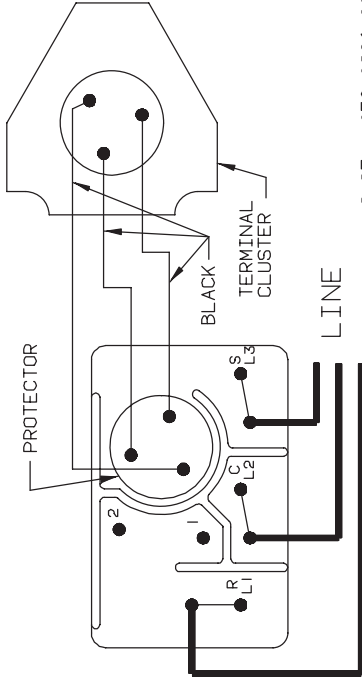

MOTOR WINDING  
 CONNECTIONS

9-93 052-0806-00

Wiring Diagram 0806



USE COPPER CONDUCTORS ONLY.  
 USE THIS EQUIPMENT ON A GROUND SYSTEM ONLY.  
 USE MINIMUM 75 °C WIRE FOR AMPACITY DETERMINATION.  
 EXTERNAL MOTOR PROTECTION-ALLOW TIME FOR RESET.  
 CRANKCASE HEATER, WHEN APPLIED, MUST BE CONNECTED ONLY  
 TO ITS RATED VOLTAGE.  
 ON 115 VOLT, CONNECT NEUTRAL TO TERMINAL "R".  
 OVERCURRENT PROTECTION DEVICE RATING AND TYPE MUST BE  
 IN ACCORDANCE WITH REGULATORY AGENCY END PRODUCT  
 APPROVALS-SEE SYSTEM NAMEPLATE.

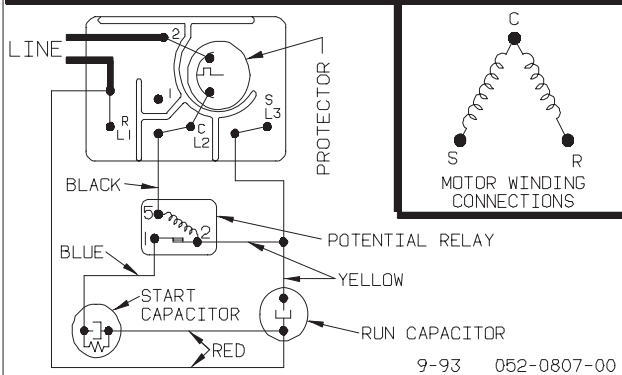

**Wiring Diagram 0807**

USE COPPER CONDUCTORS ONLY  
 USE THIS EQUIPMENT ON A GROUNDING SYSTEM ONLY  
 USE MINIMUM 75 °C WIRE FOR AMPACITY DETERMINATION.  
 EXTERNAL MOTOR PROTECTION-ALLOW TIME FOR RESET  
 ON 115 VOLT, CONNECT NEUTRAL TO TERMINAL "R" OR "1" AS SHOWN.  
 CRANKCASE HEATER, WHEN APPLIED, MUST BE CONNECTED ONLY TO ITS RATED VOLTAGE.  
 OVERCURRENT PROTECTION DEVICE RATING AND TYPE MUST BE IN ACCORDANCE WITH  
 REGULATORY AGENCY END PRODUCT APPROVALS-SEE SYSTEM NAMEPLATE.

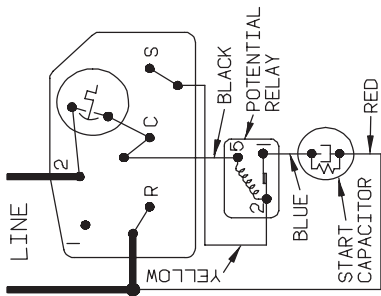
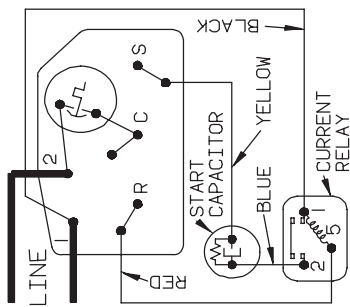
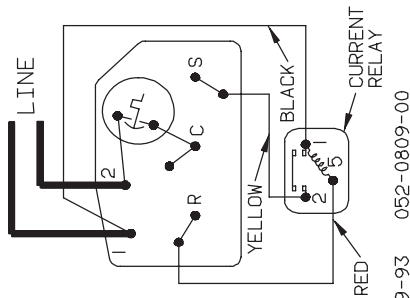

9-93 052-0809-00

Wiring Diagram 0809

USE COPPER CONDUCTORS ONLY.  
 USE THIS EQUIPMENT ON A GROUNDING SYSTEM ONLY.  
 USE MINIMUM 75 °C WIRE FOR AMPACITY DETERMINATION.  
 EXTERNAL MOTOR PROTECTION-ALLOW TIME FOR RESET.  
 PRIMARY SINGLE PHASE FAILURE PROTECTION IS PROVIDED.  
 CRANKCASE HEATER, WHEN APPLIED, MUST BE CONNECTED ONLY TO ITS RATED VOLTAGE.  
 OVERCURRENT PROTECTION DEVICE RATING AND TYPE MUST BE IN ACCORDANCE WITH  
 REGULATORY AGENCY END PRODUCT APPROVALS-SEE SYSTEM NAMEPLATE.

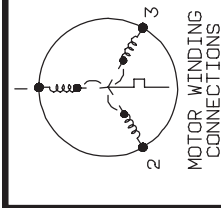
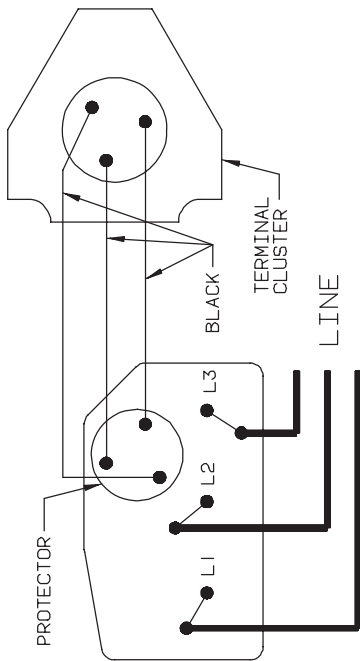

9-93 052-0810-00

Wiring Diagram 0810

USE COPPER CONDUCTORS ONLY.  
USE MINIMUM 75 °C WIRE FOR AMPACITY DETERMINATION.  
USE THIS EQUIPMENT ON A GROUNDED SYSTEM ONLY.  
PRIMARY SINGLE PHASE FAILURE PROTECTION IS PROVIDED.  
INTERNAL MOTOR PROTECTION-ALLOW TIME FOR RESET.  
CAPACITY CONTROL VALVE(S), FAN OR CRANKCASE HEATER,  
WHEN APPLIED, MUST BE CONNECTED ONLY TO THEIR RATED  
VOLTAGE.  
OVERCURRENT PROTECTION DEVICE RATING AND TYPE MUST BE  
IN ACCORDANCE WITH REGULATORY AGENCY END PRODUCT  
APPROVALS-SEE SYSTEM NAMEPLATE.

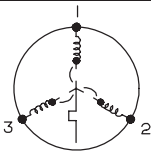
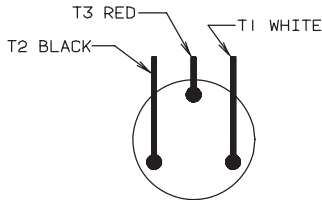

MOTOR WINDING CONNECTIONS

9-93 052-0816-00

## Wiring Diagram 0816

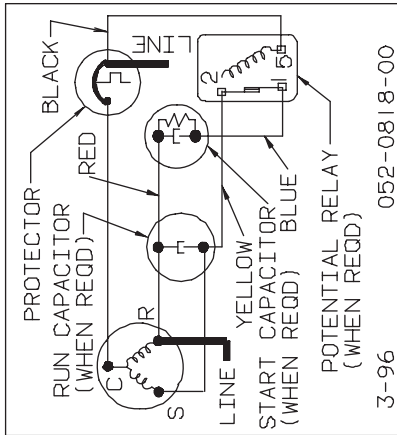

USE COPPER CONDUCTORS ONLY.  
 USE THIS EQUIPMENT ON A  
 GROUNDED SYSTEM ONLY.  
 USE MINIMUM 75 °C WIRE FOR  
 AMPACITY DETERMINATION.  
 EXTERNAL MOTOR PROTECTION-  
 ALLOW TIME FOR RESET.  
 CRANKCASE HEATER, WHEN  
 APPLIED, MUST BE CONNECTED  
 ONLY TO ITS RATED VOLTAGE.  
 ON 115 VOLT, CONNECT NEUTRAL  
 TO TERMINAL "R"  
 OVERCURRENT PROTECTION DEVICE  
 RATING AND TYPE MUST BE IN  
 ACCORDANCE WITH REGULATORY  
 AGENCY END PRODUCT APPROVALS-  
 SEE SYSTEM NAMEPLATE.

3-96 052-0819-00

**Wiring Diagram 0818/0819**

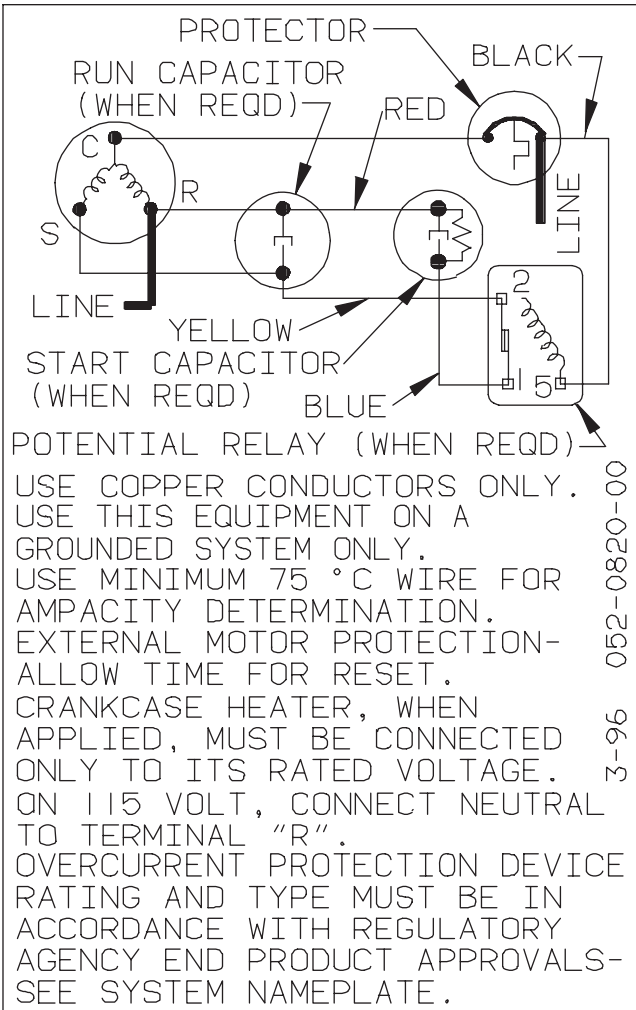

**Wiring Diagram 0820**

USE COPPER CONDUCTORS ONLY.  
 USE MINIMUM 75 °C WIRE FOR AMPACITY DETERMINATION.  
 USE THIS EQUIPMENT ON A GROUNDED SYSTEM ONLY.  
 EXTERNAL MOTOR PROTECTION-ALLOW TIME FOR RESET.  
 CRANKCASE HEATER, WHEN APPLIED, MUST BE CONNECTED  
 ONLY TO ITS RATED VOLTAGE.  
 OVERCURRENT PROTECTION DEVICE RATING AND TYPE MUST BE  
 IN ACCORDANCE WITH REGULATORY AGENCY END PRODUCT  
 APPROVALS-SEE SYSTEM NAMEPLATE.

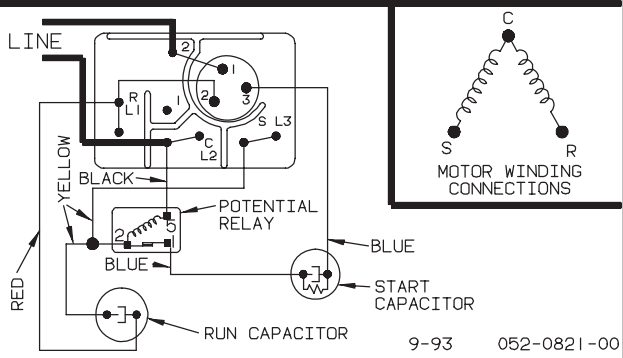

9-93 052-0821-00

Wiring Diagram 0821

USE COPPER CONDUCTORS ONLY.  
 USE THIS EQUIPMENT ON A GROUNDING SYSTEM ONLY.  
 USE MINIMUM 75 C WIRE FOR AMPACITY DETERMINATION.  
 EXTERNAL MOTOR PROTECTION-ALLOW TIME FOR RESET.  
 CRANKCASE HEATER, WHEN APPLIED, MUST BE CONNECTED  
 ONLY TO ITS RATED VOLTAGE.  
 ON 115 VOLT, CONNECT NEUTRAL TO TERMINAL "1".  
 OVERCURRENT PROTECTION DEVICE RATING AND TYPE MUST BE  
 IN ACCORDANCE WITH REGULATORY AGENCY END PRODUCT  
 APPROVALS-SEE SYSTEM NAMEPLATE.

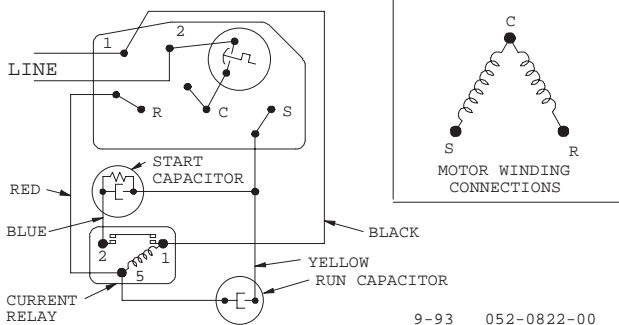

**Wiring Diagram 0822**



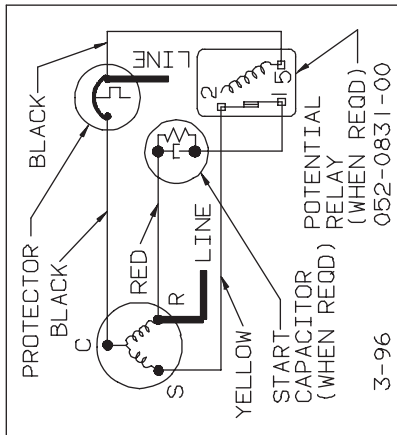

USE COPPER CONDUCTORS ONLY.  
 USE THIS EQUIPMENT ON A GROUNDING SYSTEM ONLY.  
 USE MINIMUM 75 ° C WIRE FOR AMPACITY DETERMINATION.  
 EXTERNAL MOTOR PROTECTION-ALLOW TIME FOR RESET.  
 CRANKCASE HEATER, WHEN APPLIED, MUST BE CONNECTED ONLY TO ITS RATED VOLTAGE.  
 ON 115 VOLT, CONNECT NEUTRAL TO TERMINAL "R".  
 OVERCURRENT PROTECTION DEVICE RATING AND TYPE MUST BE IN ACCORDANCE WITH REGULATORY AGENCY END PRODUCT APPROVALS-SEE SYSTEM NAMEPLATE.

9-93 052-0832-00

**Wiring Diagram 0831/0832**

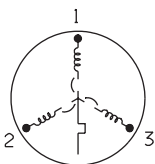

MOTOR WINDING CONNECTIONS

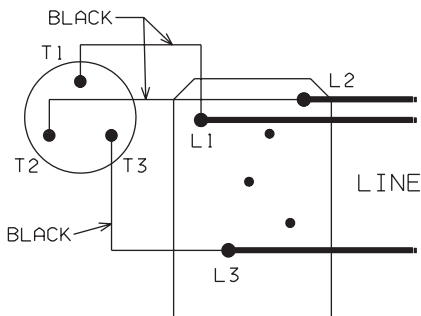

USE COPPER CONDUCTORS ONLY.

USE THIS EQUIPMENT ON A GROUNDED SYSTEM ONLY.

USE MINIMUM 75 °C WIRE FOR AMPACITY DETERMINATION.

PRIMARY SINGLE PHASE FAILURE PROTECTION IS PROVIDED.

INTERNAL MOTOR PROTECTION- ALLOW TIME FOR RESET.

CRANKCASE HEATER, WHEN APPLIED, MUST BE CONNECTED ONLY TO ITS RATED VOLTAGE.

OVERCURRENT PROTECTION DEVICE RATING AND TYPE MUST BE IN ACCORDANCE WITH REGULATORY AGENCY END PRODUCT APPROVALS-SEE SYSTEM NAMEPLATE.

9-93 052-0833-00

### Wiring Diagram 0833

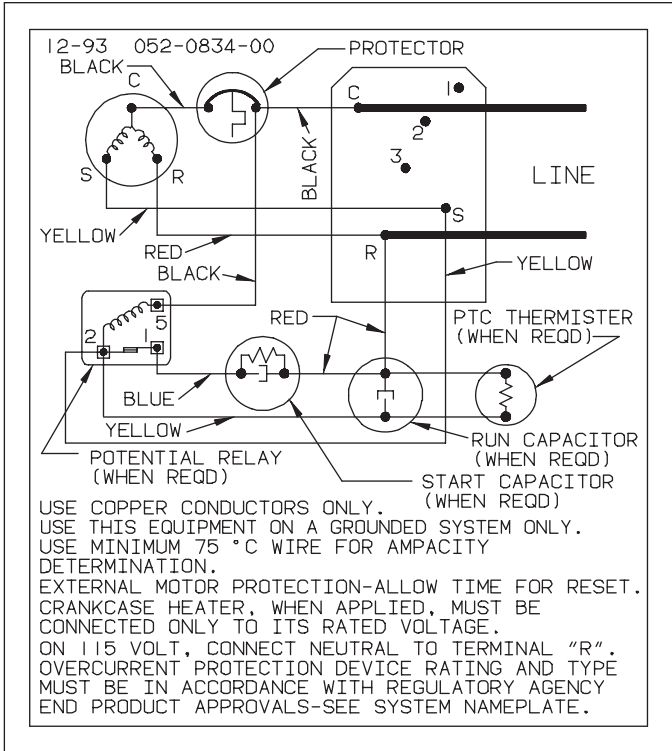

**Wiring Diagram 0834**

USE COPPER CONDUCTORS ONLY.  
USE THIS EQUIPMENT ON A GROUNDING SYSTEM ONLY.  
USE MINIMUM 75 °C WIRE FOR AMPACITY DETERMINATION.  
PRIMARY SINGLE PHASE FAILURE PROTECTION IS PROVIDED.  
INTERNAL MOTOR PROTECTION-ALLOW TIME FOR RESET.  
CRANKCASE HEATER, WHEN APPLIED, MUST BE CONNECTED ONLY  
TO ITS RATED VOLTAGE.  
OVERCURRENT PROTECTION DEVICE RATING AND TYPE MUST BE IN  
ACCORDANCE WITH REGULATORY AGENCY END PRODUCT APPROVALS-  
SEE SYSTEM NAMEPLATE.

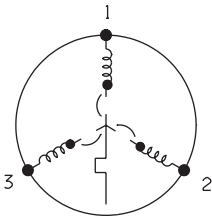

MOTOR WINDING CONNECTIONS

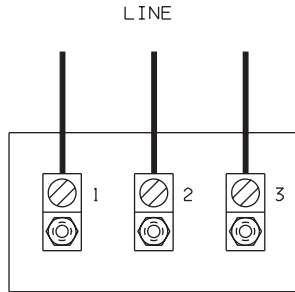

9-93 052-0837-00

## Wiring Diagram 0837

USE COPPER CONDUCTORS ONLY.

11-93 052-0840-00

USE THIS EQUIPMENT ON A GROUNDED SYSTEM ONLY.

USE MINIMUM 75 °C WIRE FOR AMPACITY DETERMINATION.

PRIMARY SINGLE PHASE FAILURE PROTECTION IS PROVIDED.

INTERNAL MOTOR PROTECTION-ALLOW TIME FOR RESET.

CRANKCASE HEATER, WHEN APPLIED, MUST BE CONNECTED ONLY TO ITS RATED VOLTAGE.

OVERCURRENT PROTECTION DEVICE RATING AND TYPE MUST BE IN ACCORDANCE WITH REGULATORY AGENCY END PRODUCT APPROVALS-SEE SYSTEM NAMEPLATE.

N'UTILISER QUE DES CONDUCTEURS EN CUIVRE.

UTILISER CE MATERIEL SEULEMENT DANS UN RESEAU MIS A LA TERRE.

UTILISER UN FIL D'AU MOINS 75 °C POUR DETERMINER LE COURANT ADMISSIBLE.

PROTECTION PRIMAIRE MONOPHASEE FOURNIE.

PROTECTION INTERNE DU MOTEUR: PREVOIR UN DELAI POUR LE REARMEMENT.

LE CHAUFFE-CARTER NE DOIT ETRE CONNECTE QU'A UN RESEAU DE MEME TENSION NOMINALE.

LE TYPE ET LES CARACTERISTIQUES NOMINALES DU DISPOSITIF DE PROTECTION CONTRE LES SURINTENSITES DOIVENT ETRE CONFORMES AUX EXIGENCES DES POUVOIRS DE REGLEMENTATION VISANT LE PRODUIT FINI. VOIR LA PLAQUE SIGNALETIQUE.

NUR KUPFERVERBINDUNGEN VERWENDEN.

ANLAGE NUR MIT ERDUNG VERWENDEN.

ZUR BESTIMMUNG DES BETRIEBSSTROMES MÜSSEN KABEL VERWENDET WERDEN, DIE FÜR EINE BELASTUNG VON MINDESTENS 75 °C GEEIGNET SIND.

SCHUTZ BEI PHASENAUSFALL AUF DER PRIMARSEITE IST GEWAHRLEISTET.

INTERNER MOTORSCHUTZ-BENÖTIGT ZEIT ZUM RÜCKSCHALTEN.

BEI VERWENDUNG EINES KURBELGEHAUSEHEIZERS DIESEN NUR MIT NENNSPANNUNG BETREIBEN.

NENNLEISTUNG UND TYP DES ÜBERSTROMSCHUTZSCHALTERS MÜSSEN IN ÜBEREINSTIMMUNG MIT ZUTREFFENDEN VORSCHRIFTEN SEIN-BITTE TYPSCHEID BEACHTEN.

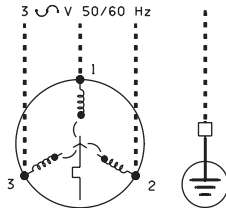

Wiring Diagram 0840

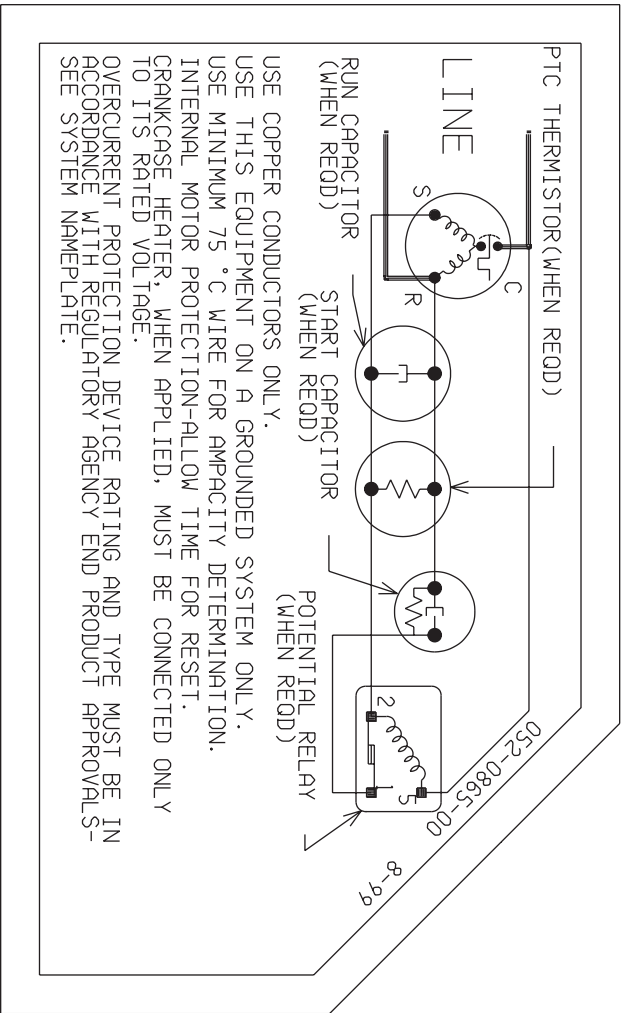

USE COPPER CONDUCTORS ONLY.

USE THIS EQUIPMENT ON A GROUNDDED SYSTEM ONLY.

USE MINIMUM 75 °C WIRE FOR AMPACITY DETERMINATION.

INTERNAL MOTOR PROTECTION-ALLOW TIME FOR RESET.

CRANKCASE HEATER, WHEN APPLIED, MUST BE CONNECTED ONLY TO ITS RATED VOLTAGE.

OVERCURRENT PROTECTION DEVICE RATING AND TYPE MUST BE IN ACCORDANCE WITH REGULATORY AGENCY END PRODUCT APPROVALS-SEE SYSTEM NAMEPLATE.

**Wiring Diagram 0865**

USE COPPER CONDUCTORS ONLY. USE THIS EQUIPMENT ON A GROUNDED SYSTEM ONLY. USE MINIMUM 75 °C WIRE FOR AMPACITY DETERMINATION. INTERNAL MOTOR PROTECTION-ALLOW TIME FOR RESET. PRIMARY SINGLE PHASE FAILURE PROTECTION IS PROVIDED. CRANKCASE HEATER, WHEN APPLIED, MUST BE CONNECTED ONLY TO ITS RATED VOLTAGE. OVERCURRENT PROTECTION DEVICE RATING AND TYPE MUST BE IN ACCORDANCE WITH REGULATORY AGENCY END PRODUCT APPROVALS -SEE SYSTEM NAMEPLATE. TO CORRECT IMPROPER MOTOR ROTATION, SWITCH ANY TWO SUPPLY LINES.

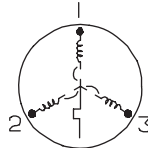
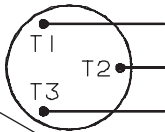

MOTOR  
WINDING CONNECTION  
03-96 052-0880-00

**Wiring Diagram 0880**

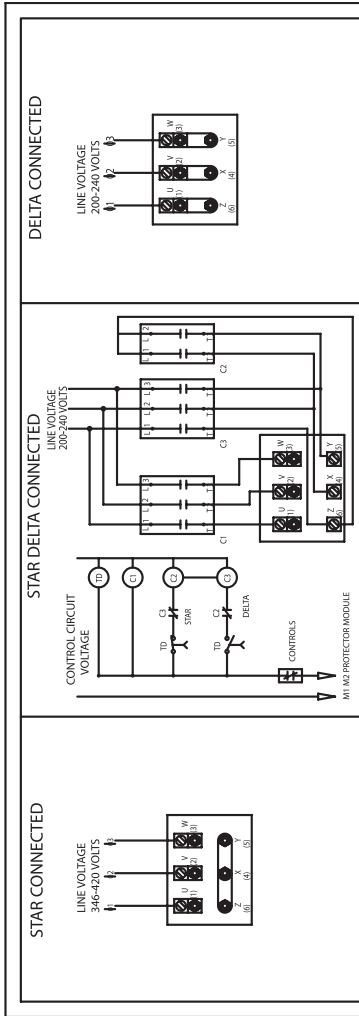

Wiring Diagram 0897 (Top)



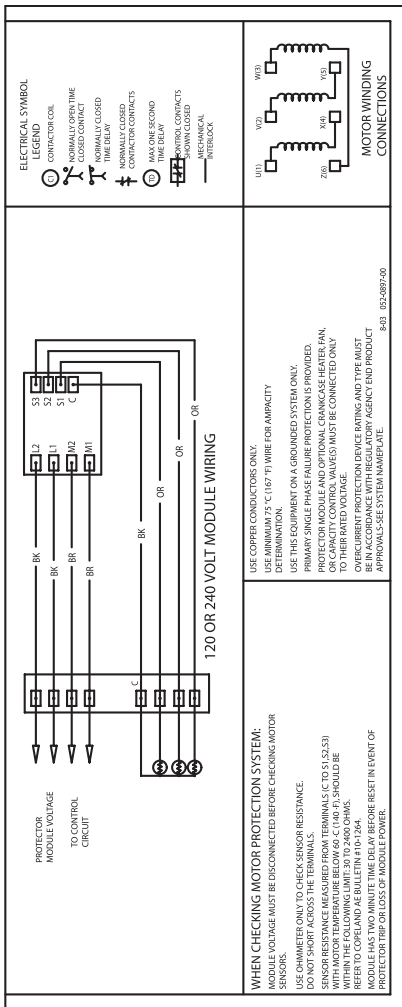

**Wiring Diagram 0897 (Bottom)**

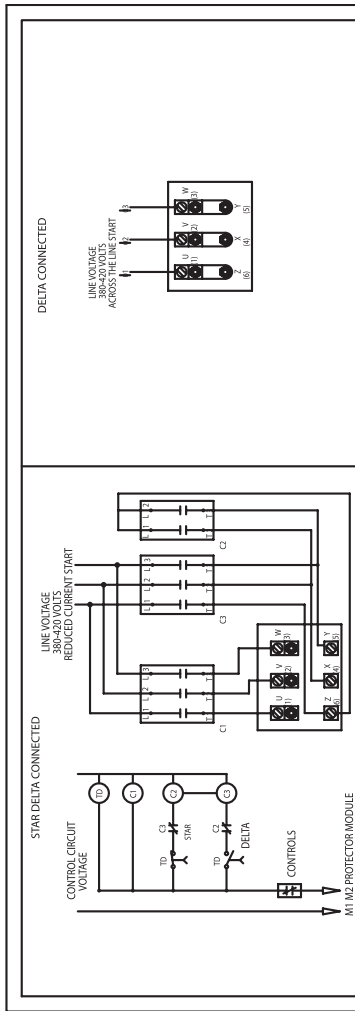

**Wiring Diagram 0900 (Top)**

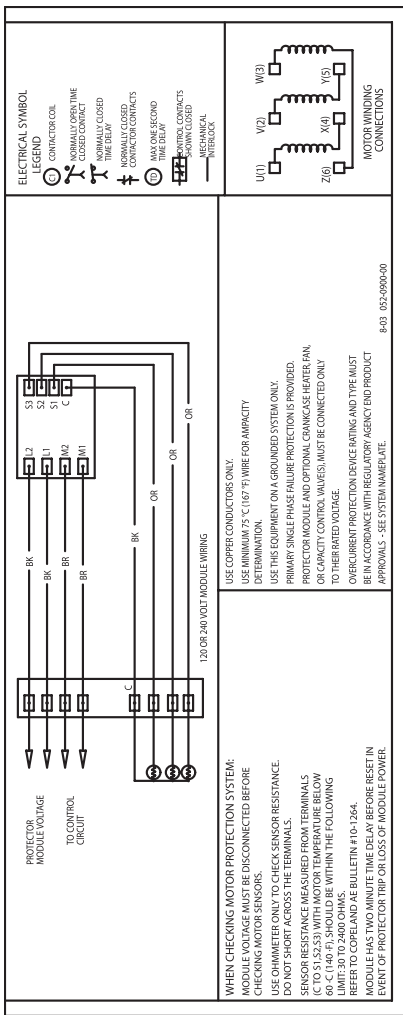

**Wiring Diagram 0900 (Bottom)**

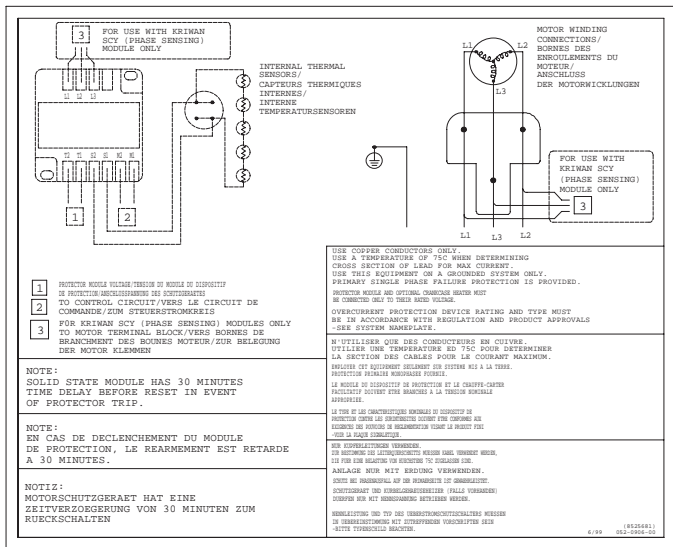

Wiring Diagram 0906

**This page is left blank intentionally.**

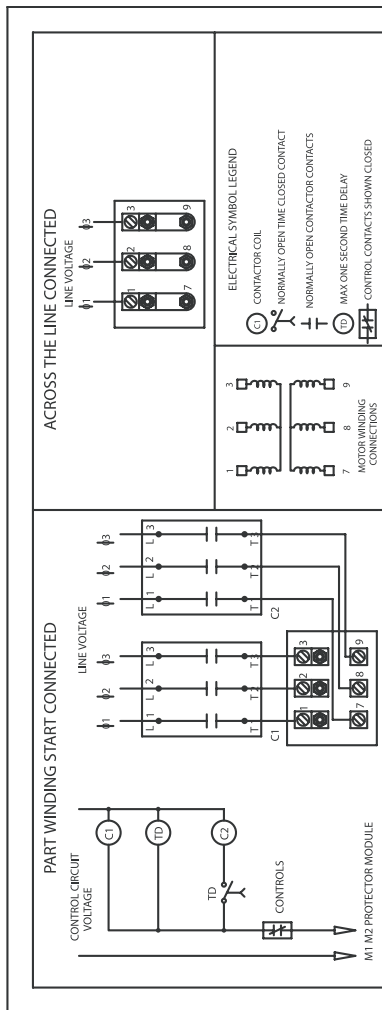

**Wiring Diagram 0914 (Top)**

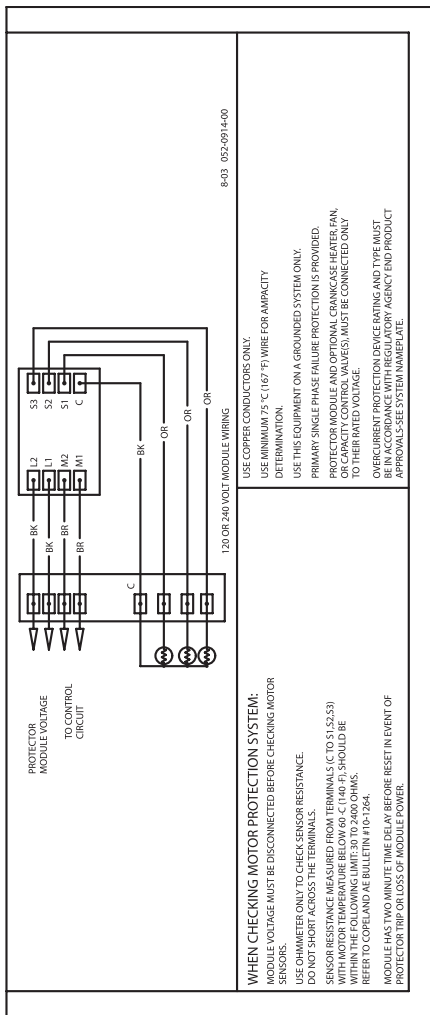

**WHEN CHECKING MOTOR PROTECTION SYSTEM:**

- MODULE VOLTAGE MUST BE DISCONNECTED BEFORE CHECKING MOTOR SENSORS.
- USE OHMMETER ONLY TO CHECK SENSOR RESISTANCE. DO NOT SHORT ACROSS THE TERMINALS.
- SENSOR RESISTANCE MEASURED FROM TERMINALS (C TO S1, S2, S3) WITH MOTOR TEMPERATURE BELOW 60 °C (140 °F), SHOULD BE WITHIN THE FOLLOWING LIMIT: 30 TO 2400 OHMS. REFER TO COPELAND AE BULLETIN #10-1264.
- MODULE HAS TWO MINUTE TIME DELAY BEFORE RESET IN EVENT OF PROTECTOR TRIP OR LOSS OF MODULE POWER.

USE COPPER CONDUCTORS ONLY.  
USE MINIMUM 75 °C (167 °F) WIRE FOR AMPACITY DETERMINATION.

USE THIS EQUIPMENT ON A GROUNDING SYSTEM ONLY.  
PRIMARY SINGLE PHASE FAILURE PROTECTION IS PROVIDED.  
PROTECTOR MODULE AND OPTIONAL CRANKCASE HEATER FAN, OR CAPACITY CONTROL VALVES, MUST BE CONNECTED ONLY TO THEIR RATED VOLTAGE.  
OVERCURRENT PROTECTION DEVICE RATING AND TYPE MUST BE DETERMINED BY AGENCY END PRODUCT APPROVALS-SEE SYSTEM NAMEPLATE.

**Wiring Diagram 0914 (Bottom)**

## Wiring Diagram 0929

USE MINIMUM 75C COPPER

WIRE FOR AMPACITY

DETERMINATION. WHEN PROVIDED,

CRANKCASE HEATER AND FAN

MUST BE CONNECTED ONLY TO

THEIR RATED VOLTAGE.

SYSTEM OVERCURRENT

PROTECTION DEVICE RATING

AND TYPE MUST BE IN

ACCORDANCE WITH REGULATORY

AGENCY END PRODUCT

APPROVALS - SEE SYSTEM

NAMEPLATE. FAN LEADS

ARE FACTORY PROVIDED

ON CONDENSING UNITS.

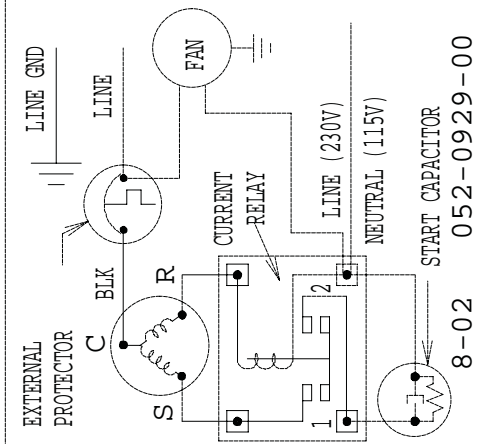

8-02 052-0929-00



USE MINIMUM 75°C COPPER WIRE FOR AMPACITY DETERMINATION. WHEN PROVIDED, CRANKCASE HEATER AND FAN MUST BE CONNECTED ONLY TO THEIR RATED VOLTAGE. SYSTEM OVERCURRENT PROTECTION DEVICE RATING AND TYPE MUST BE IN ACCORDANCE WITH REGULATORY AGENCY END PRODUCT APPROVALS - SEE SYSTEM NAMEPLATE. FAN LEADS ARE FACTORY PROVIDED ON CONDENSING UNITS

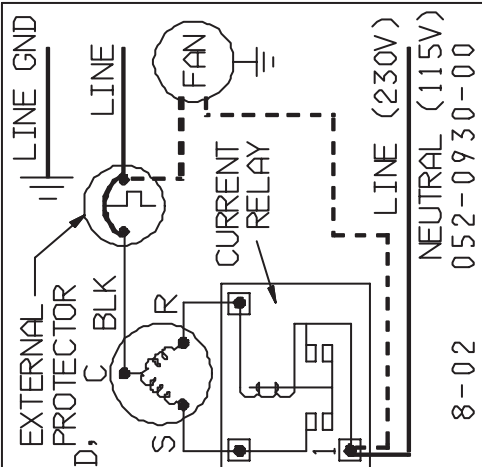

Wiring Diagram 0930

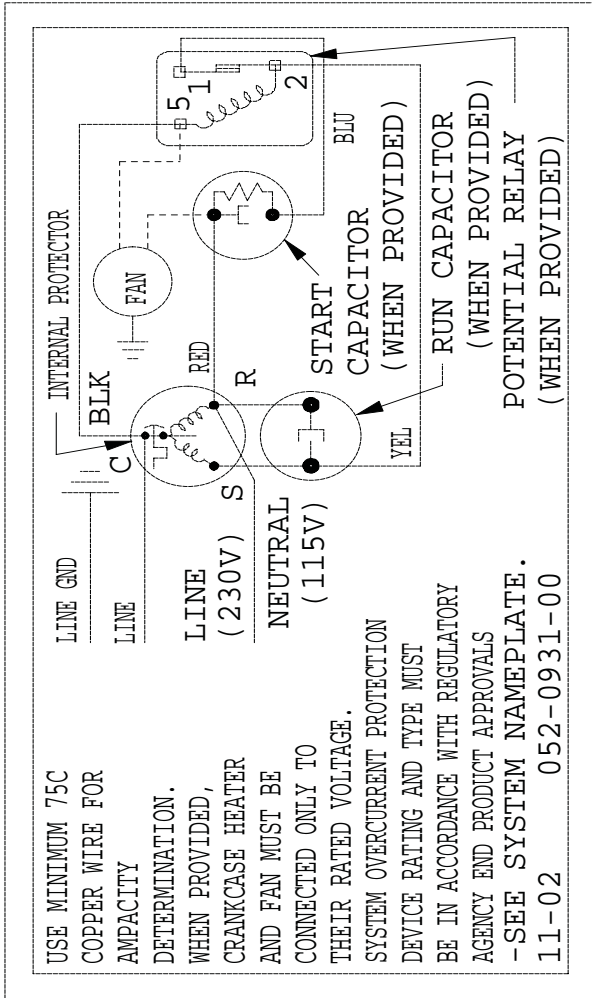

Wiring Diagram 0931

USE MINIMUM 75C COPPER WIRE FOR AMPACITY DETERMINATION. WHEN PROVIDED, CRANKCASE HEATER AND FAN MUST BE CONNECTED ONLY TO THEIR RATED VOLTAGE. SYSTEM OVERCURRENT PROTECTION DEVICE RATING AND TYPE MUST BE IN ACCORDANCE WITH REGULATORY AGENCY END PRODUCT APPROVALS (WHEN PROVIDED) -SEE SYSTEM NAMEPLATE.

11-02 052-0932-00

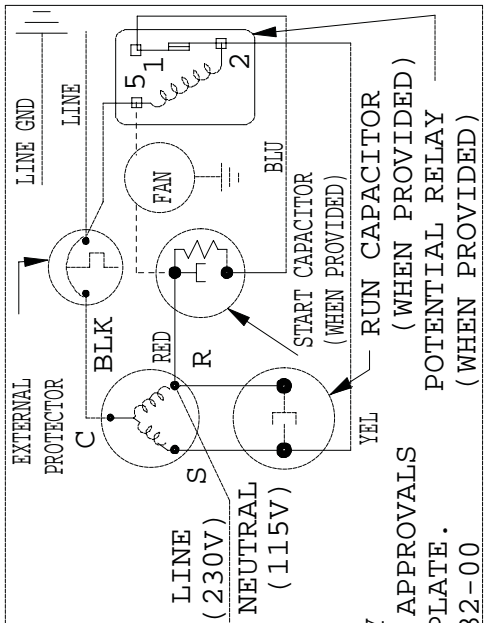

Wiring Diagram 0932

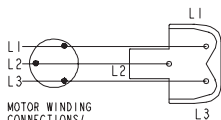

MOTOR WINDING  
CONNECTIONS/  
BORNES DES  
ENROULEMENTS DU  
MOTEUR/ANSCHLUSS  
DER MOTORWICKLUNGEN

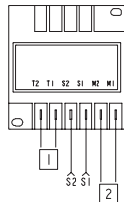
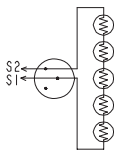

**SYMBOLS/SYMBOLS/SYMBOL**

⊕ THERMAL SENSORS/CAPTEURS THERMIQUES

/TEMPERATURSENSOREN

1] PROTECTOR MODULE VOLTAGE/TENSION DU MODULE DISPOSITIF

DE PROTECTION/ANSCHLUSSPANNUNG DES SCHUTZGERÄTES

2] TO CONTROL CIRCUIT/VERS LE CIRCUIT DE

COMMANDE/ZUM STEUERSTRONKREIS

USE COPPER CONDUCTORS ONLY.

USE MINIMUM 75° C WIRE FOR ANPCACITY DETERMINATION.

USE THIS EQUIPMENT ON A GROUNDED SYSTEM ONLY.

PRIMARY SINGLE PHASE FAILURE PROTECTION IS PROVIDED.

PROTECTOR MODULE AND OPTIONAL CRANKCASE HEATER MUST

BE CONNECTED ONLY TO THEIR RATED VOLTAGE.

OVERCURRENT PROTECTION DEVICE RATING AND TYPE MUST

BE IN ACCORDANCE WITH REGULATORY AGENCY END PRODUCT APPROVALS

-SEC SYSTEM NAMEPLATE.

**WHEN CHECKING SOLID STATE MODULE:**

DO NOT SHORT ACROSS S1 AND S2 SENSOR TERMINALS

MODULE HAS 30 MINUTES TIME DELAY BEFORE RESET IN  
EVENT OF PROTECTOR TRIP.

N'UTILISER QUE DES CONDUCTEURS EN CUIVRE.

UTILISER UN FIL D'AU MOINS 75° C POUR DETERMINER LE COURANT ADMISSIBLE.

EMPLOYER CET EQUIPEMENT SEULEMENT SUR SYSTEME MIS A LA TERRE.

PROTECTION PRIMAIRE MONOPHASE FOURNIE.

LE MODULE DU DISPOSITIF DE PROTECTION ET LE CHAUFFE-CARTER

FACULTATIF DOIVENT ETRE BRANCHEES A LA TENSION NOMINALE

APPROPRIEE.

LE TYPE ET LES CARACTERISTIQUES NOMINALES DU DISPOSITIF DE

PROTECTION CONTRE LE SURINTENSITES DOIVENT ETRE CONFORMES AUX

EXIGENCES DES POUVOIRS DE REGLEMENTATION VISANT LE PRODUIT FINI

-VOIR LA PLAQUE SIGNALÉTIQUE.

**LORS DE LA VÉRIFICATION DU MODULE ÉLECTRONIQUE:**

EN CAS DÉCLENCHEMENT DU MODULE DISPOSITIF DE  
PROTECTION, LE REARMEMENT EST RETARDÉ A 30 MINUTES.

**BEI PRÜFUNG DES MOTORSCHUTZGERÄTES:**

DIE SENSORANSCHLÜSSE S1 UND S2 DÜRFEN NICHT  
ÜBERBRÜCKT WERDEN.

WENN DAS SCHUTZSYSTEM ABSCHALTET, HAT DAS SCHUTZGERÄT  
EINE ZEITVERZÖGERUNG VON 30 MINUTEN ZUM RÜCKSCHALTEN.

NUR KUPFERLEITUNGEN VERWENDEN.

ZUR BESTIMMUNG DES BETRIEBSSTROMES MÜSSEN KABEL VERWENDET WERDEN,

DIE FÜR EINE BELASTUNG VON MINDESTENS 75° C GEEIGNET SIND.

ANLAGE NUR MIT ERDUNG VERWENDEN.

SCHUTZ BEI PHASENSCHWUND AUF DER PRIMÄRSEITE IST GEWÄHRLEISTET.

SCHUTZGERÄT UND KORBELGEHÄUSEHEIZER (FALLS VORHANDEN)

DÜRFEN NUR MIT NENNSPANNUNG BETRIEBEN WERDEN.

NENNLEISTUNG UND TYP DES ÜBERSCHUTZSCHALTERS MÜSSEN

IN ÜBEREINSTIMMUNG MIT ZUTREFFENDEN VORSCHRIFTEN SEIN

-BITTE TYPENSCHILD BEACHTEN.

6-02 052-0953-00

**Wiring Diagram 0953**

USE MINIMUM 75 °C COPPER WIRE FOR AMPACITY DETERMINATION.  
 CRANKCASE HEATER, OR FAN MUST BE CONNECTED ONLY TO ITS RATED VOLTAGE.

OVERCURRENT PROTECTION DEVICE RATING AND TYPE MUST BE IN ACCORDANCE WITH REGULATORY AGENCY END PRODUCT APPROVALS—SEE SYSTEM NAMEPLATE.

PRIMARY SINGLE PHASE FAILURE PROTECTION IS PROVIDED.  
 INTERNAL MOTOR PROTECTION—ALLOW TIME FOR RESET.

4-01 052-0980-00

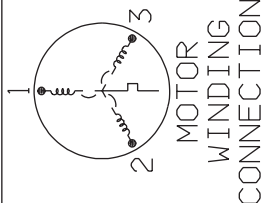
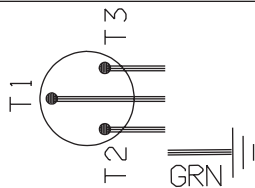

MOTOR WINDING CONNECTIONS

**Wiring Diagram 0980**

USE COPPER CONDUCTORS ONLY. USE THIS EQUIPMENT ON A GROUNDED SYSTEM ONLY. USE MINIMUM 75 °C WIRE FOR AMPACITY DETERMINATION. INTERNAL MOTOR PROTECTION-ALLOW TIME FOR RESET. PRIMARY SINGLE PHASE FAILURE PROTECTION IS PROVIDED. CRANKCASE HEATER, WHEN APPLIED, MUST BE CONNECTED ONLY TO ITS RATED VOLTAGE. OVERCURRENT PROTECTION DEVICE RATING AND TYPE MUST BE IN ACCORDANCE WITH REGULATORY AGENCY END PRODUCT APPROVALS -SEE SYSTEM NAMEPLATE. TO CORRECT IMPROPER MOTOR ROTATION. SWITCH ANY TWO SUPPLY LINES.

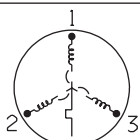

MOTOR  
WINDING CONNECTION  
2-94 052-1199-00

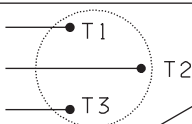

## Wiring Diagram 1199

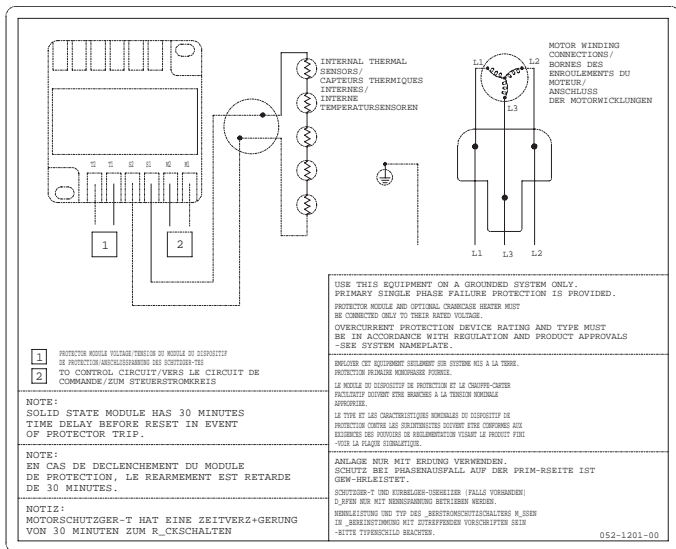

Wiring Diagram 1201

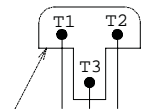

**CONNECTOR  
BLOCK  
(WHEN REQD)**

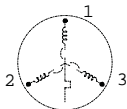

**MOTOR WINDING  
CONNECTIONS**

**USE COPPER CONDUCTORS  
ONLY.**

**USE THIS EQUIPMENT ON A  
GROUNDED SYSTEM ONLY.**

**USE MINIMUM 75 C WIRE FOR  
AMPACITY DETERMINATION.**

**PRIMARY SINGLE PHASE FAILURE  
PROTECTION IS PROVIDED.**

**INTERNAL MOTOR PROTECTION-ALLOW  
TIME FOR RESET.**

**CRANKCASE HEATER, WHEN APPLIED,  
MUST BE CONNECTED ONLY TO ITS  
RATED VOLTAGE.**

**OVERCURRENT PROTECTION DEVICE  
RATING AND TYPE MUST BE IN  
ACCORDANCE WITH REGULATORY AGENCY  
END PRODUCT APPROVALS- SEE SYSTEM  
NAMEPLATE.**

005-1211-01 8-06

## Wiring Diagram 005-1211-01



USE COPPER CONDUCTORS ONLY. USE MINIMUM  
75° C WIRE FOR AMPACITY DETERMINATION.  
INTERNAL MOTOR PROTECTION - ALLOW TIME  
FOR RESET OVERCURRENT PROTECTION  
DEVICE RATING AND TYPE MUST BE IN  
ACCORDANCE WITH REGULATORY AGENCY END  
PRODUCT APPROVALS-SEE SYSTEM NAMEPLATE  
CRANKCASE HEATER, WHEN APPLIED,  
MUST BE CONNECTED ONLY TO ITS RATED  
VOLTAGE. TO CORRECT IMPROPER ROTATION  
OF THREE PHASE MODELS, SWITCH ANY  
TWO SUPPLY LINES. REFER TO THE  
APPLICABLE SYSTEM WIRING DIAGRAM.

XX

8-06 005-1213-00

**Wiring Diagram 005-1213**

USE MINIMUM 75C COPPER WIRE FOR AMPACITY DETERMINATION. WHEN PROVIDED, CRANKCASE HEATER AND FAN MUST BE CONNECTED ONLY TO THEIR RATED VOLTAGE. SYSTEM OVERCURRENT PROTECTION DEVICE RATING AND TYPE MUST BE IN ACCORDANCE WITH REGULATORY AGENCY END PRODUCT APPROVALS -SEE SYSTEM NAMEPLATE.

8-02 052-1223-00

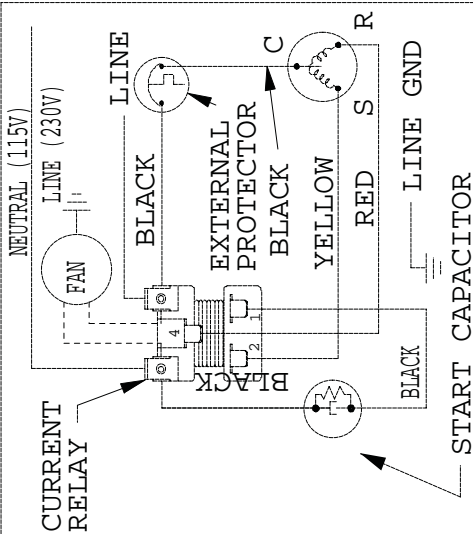

Wiring Diagram 1223

USE COPPER CONDUCTORS ONLY. USE MINIMUM  
75°C WIRE FOR AMPACITY DETERMINATION.  
INTERNAL MOTOR PROTECTION-ALLOW TIME  
FOR RESET. OVERCURRENT PROTECTION  
DEVICE RATING AND TYPE MUST BE IN  
ACCORDANCE WITH REGULATORY AGENCY END  
PRODUCT APPROVALS-SEE SYSTEM NAMEPLATE.  
CRANKCASE HEATER, WHEN APPLIED,  
MUST BE CONNECTED ONLY TO ITS RATED  
VOLTAGE. TO CORRECT IMPROPER ROTATION  
OF THREE PHASE MODELS, SWITCH ANY  
TWO SUPPLY LINES. REFER TO THE  
APPLICABLE SYSTEM WIRING DIAGRAM.

XX

005-1270-00

8-06

**Wiring Diagram 005-1270**

USE COPPER CONDUCTORS ONLY. USE THIS EQUIPMENT ON A GROUNDED SYSTEM ONLY. USE MINIMUM 75°C WIRE FOR AMPACITY DETERMINATION. INTERNAL MOTOR PROTECTION-ALLOW TIME FOR RESET. PRIMARY SINGLE PHASE FAILURE PROTECTION IS PROVIDED. CRANKCASE HEATER, WHEN APPLIED, MUST BE CONNECTED ONLY TO ITS RATED VOLTAGE. OVERCURRENT PROTECTION DEVICE RATING AND TYPE MUST BE IN ACCORDANCE WITH REGULATORY AGENCY END PRODUCT APPROVALS -SEE SYSTEM NAMEPLATE. TO CORRECT IMPROPER MOTOR ROTATION. SWITCH ANY TWO SUPPLY LINES. XX

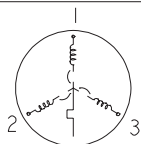

MOTOR  
WINDING CONNECTION

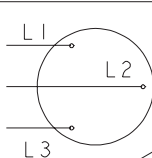

005-1271-00

8-06

### Wiring Diagram 005-1271

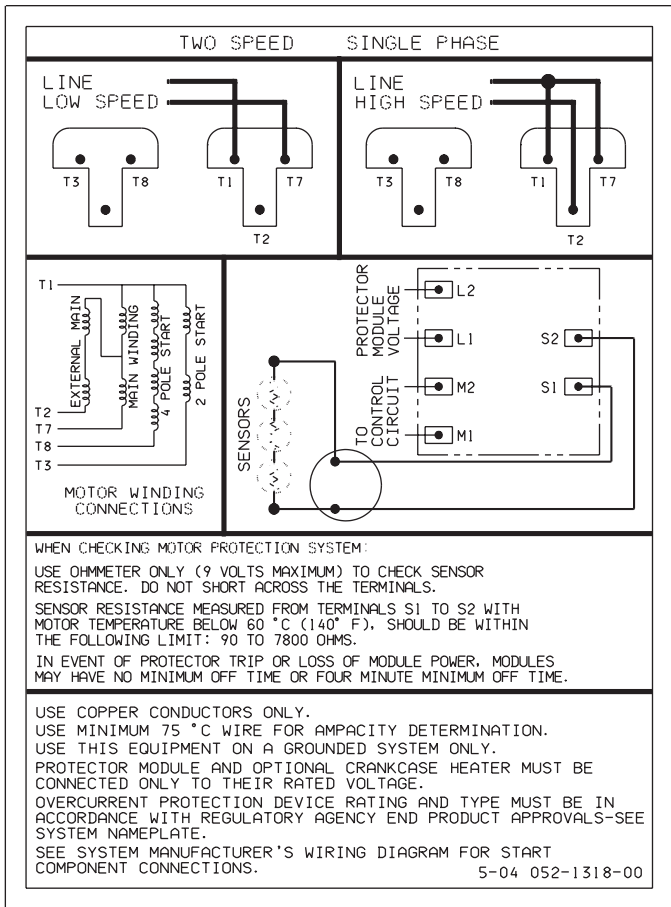

**Wiring Diagram 1318**

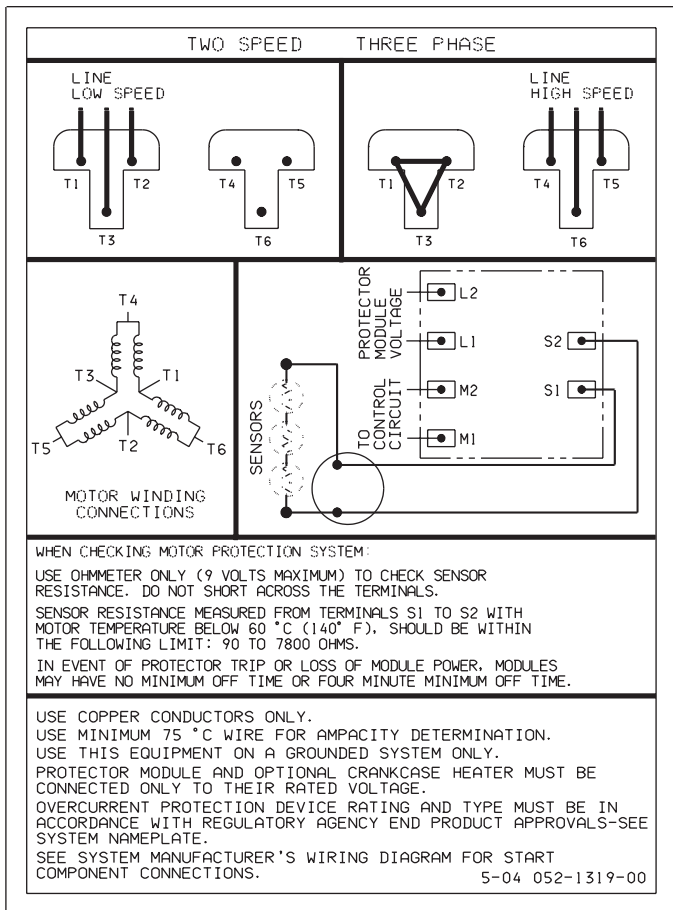

**Wiring Diagram 1319**

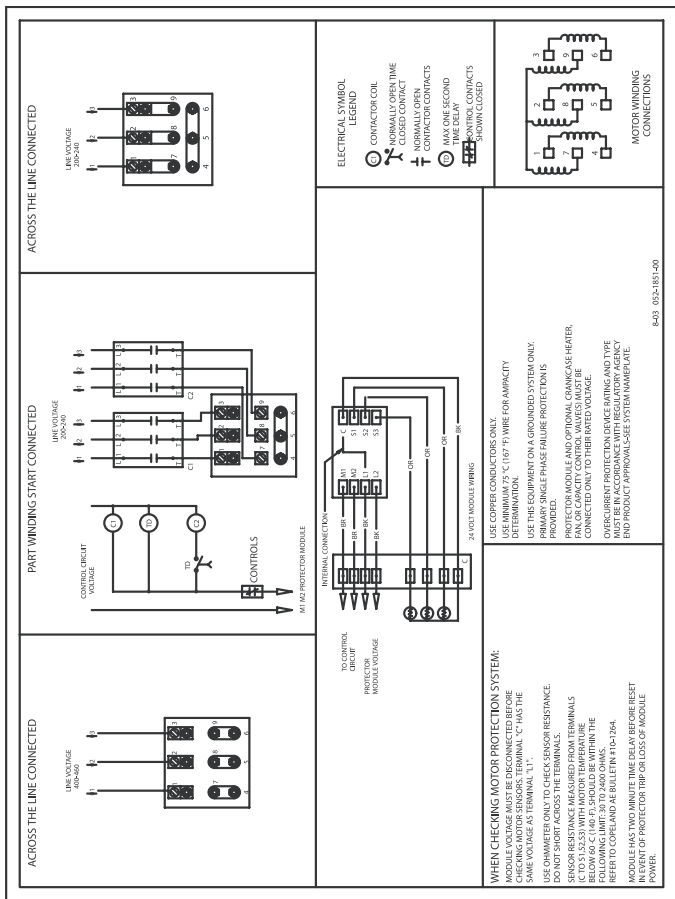

Wiring Diagram 1851

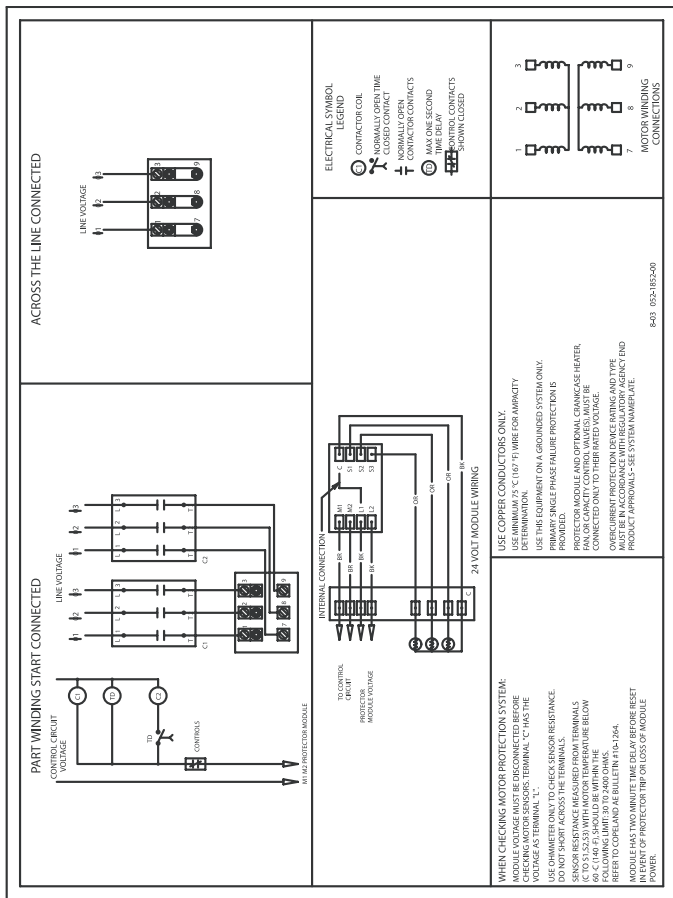

Wiring Diagram 1852



**This page is left blank intentionally.**

## WHEN CHECKING MOTOR PROTECTION SYSTEM:

MODULE VOLTAGE MUST BE DISCONNECTED BEFORE CHECKING MOTOR SENSORS.

USE OHMMETER ONLY TO CHECK SENSOR RESISTANCE.  
DO NOT SHORT ACROSS THE TERMINALS.

SENSOR RESISTANCE MEASURED FROM TERMINALS (C TO S1,S2,S3) WITH MOTOR TEMPERATURE BELOW 60 °C (140 °F), SHOULD BE WITHIN THE FOLLOWING LIMIT: 30 TO 2400 OHMS.

REFER TO EMERSON CLIMATE TECHNOLOGIES, INC.  
AE BULLETIN #10-1264.

MODULE HAS TWO MINUTE TIME DELAY BEFORE RESET IN EVENT OF PROTECTOR TRIP OR LOSS OF MODULE POWER.

USE COPPER CONDUCTORS ONLY.

USE MINIMUM 75 °C (167 °F) WIRE FOR AMPACITY DETERMINATION.

USE THIS EQUIPMENT ON A GROUNDED SYSTEM ONLY.

PRIMARY SINGLE PHASE FAILURE PROTECTION IS PROVIDED.

PROTECTOR MODULE AND OPTIONAL CRANKCASE HEATER, FAN, OR CAPACITY CONTROL VALVE(S) MUST BE CONNECTED ONLY TO THEIR RATED VOLTAGE.

OVERCURRENT PROTECTION DEVICE RATING AND TYPE MUST BE IN ACCORDANCE WITH REGULATORY AGENCY END PRODUCT APPROVALS-SEE SYSTEM NAMEPLATE.

7-06

052-2167-00

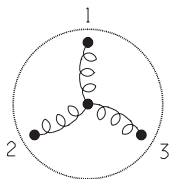

MOTOR WINDING CONNECTIONS

## Wiring Diagram 2167 (Left Side)

# ACROSS THE LINE CONNECTED

LINE VOLTAGE

$\phi 1$     $\phi 2$     $\phi 3$

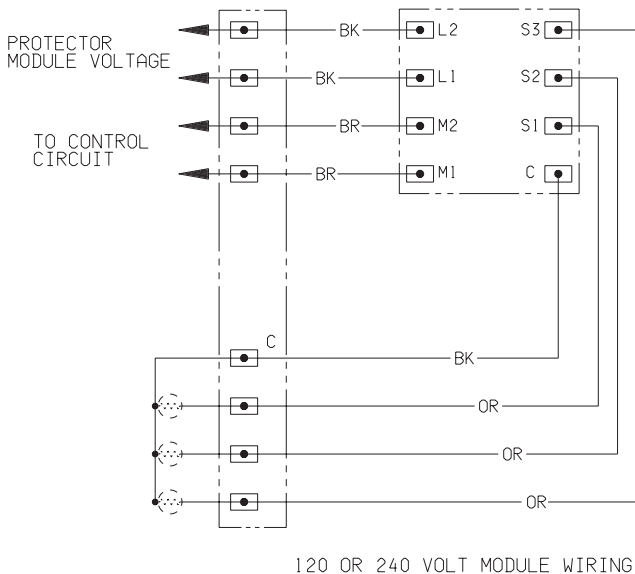
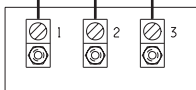

**Wiring Diagram 2167 (Right Side)**

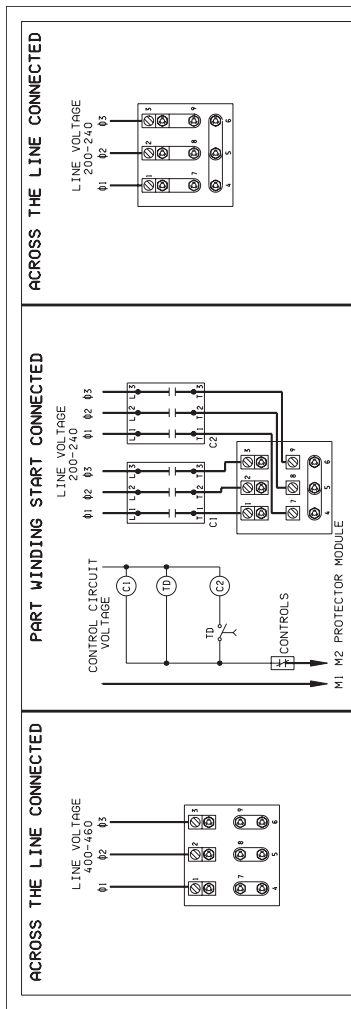

Wiring Diagram 2169 (Top)

## Wiring Diagram 2169 (Bottom)

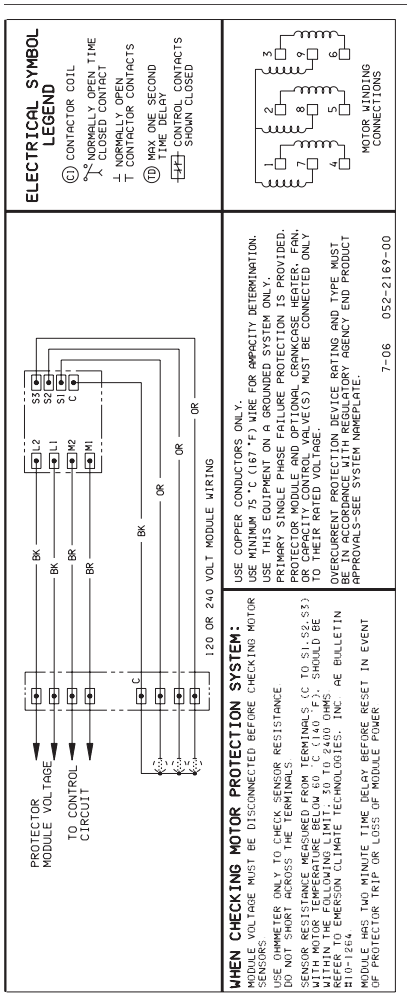

**Wiring Diagram 2170 (Top)**

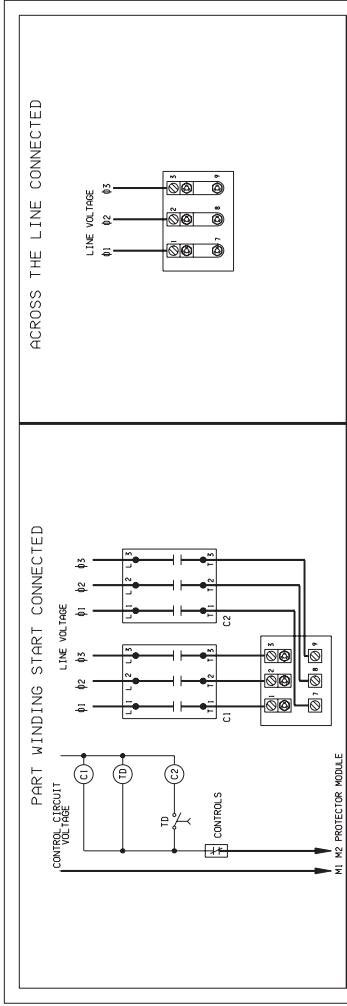

## Wiring Diagram 2170 (Bottom)

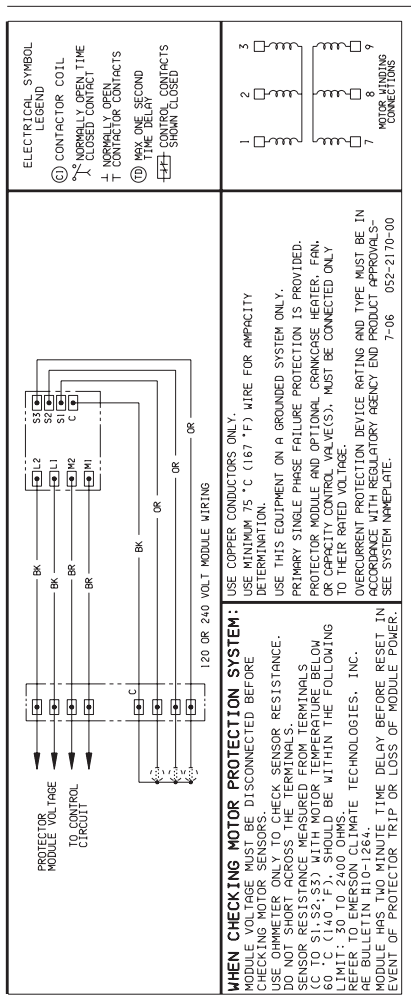

PROTECTOR MODULE VOLTAGE  
TENSION DU MODULE DE PROTECTION  
VOLTAJE DEL MODULO PROTECTOR

TO CONTROL CIRCUIT  
VERS LE CIRCUIT DE CONTROLE  
AL CIRCUITO DE CONTROL

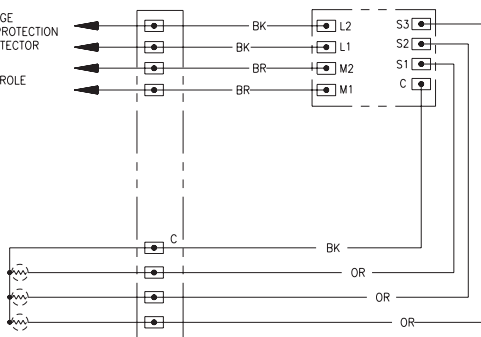

120 OR 240 VOLT MODULE WIRING

**WHEN CHECKING MOTOR PROTECTION SYSTEM:**

MODULE VOLTAGE MUST BE DISCONNECTED BEFORE CHECKING MOTOR SENSORS.  
USE OHMMETER ONLY TO CHECK SENSOR RESISTANCE.  
DO NOT SHORT ACROSS THE TERMINALS.

SENSOR RESISTANCE MEASURED FROM TERMINALS (C TO S1,S2,S3) WITH MOTOR TEMPERATURE BELOW 60 °C (140 °F), SHOULD BE WITHIN THE FOLLOWING LIMIT: 30 TO 2400 OHMS.  
REFER TO EMERSON CLIMATE TECHNOLOGIES, INC. AE BULLETIN #10-1264.

MODULE HAS TWO MINUTE TIME DELAY BEFORE RESET IN EVENT OF PROTECTOR TRIP OR LOSS OF MODULE POWER.

**POUR VÉRIFIER LE SYSTÈME DE PROTECTION DU MOTEUR:**

LA TENSION DU MODULE DOIT ÊTRE DECONNECTÉE AVANT DE VÉRIFIER LES CAPTEURS DU MOTEUR.

UTILISER UNIQUEMENT UN OHMMÈTRE POUR VÉRIFIER LA RÉSISTANCE DE CAPTEUR.  
NE PAS CAUSER DE COURT-CIRCUIT ENTRE LES BORNES.

LA RÉSISTANCE DE CAPTEUR MESURÉE ENTRE LES BORNES (C À S1,S2,S3) AVEC LA TEMPÉRATURE DU MOTEUR INFÉRIEURE À 60 °C (140 °F), DOIT ÊTRE DANS LA PLAGE SUIVANTE: 30 À 2400 OHMS.

SE REPORTER AU BULLETIN EMERSON CLIMATE TECHNOLOGIES, INC. AE N° 10-1264.

LE MODULE A UN TEMPS D'ATTENTE DE DEUX MINUTES AVANT DE SE REINITIALISER EN CAS DE DÉCLANCHEMENT DE LA PROTECTION OU DE COUPEURE DE L'ALIMENTATION DU MODULE.

**AL VERIFICAR EL SISTEMA DE PROTECCIÓN DEL MOTOR:**

DEBE DESCONECTAR EL VOLTAJE DEL MODULO ANTES DE VERIFICAR LOS SENSORES DEL MOTOR.  
UTILICE EL OHMETRO UNICAMENTE PARA VERIFICAR LA RESISTENCIA DEL SENSOR.

NO HAGA UN CORTO CON LAS TERMINALES.

LA RESISTENCIA DEL SENSOR MEDIDA EN LAS TERMINALES (C A S1,S2,S3) CON LA TEMPERATURA DEL MOTOR POR DEBAJO DE 60 °C (140 °F), DEBE ESTAR DENTRO DEL SIGUIENTE LÍMITE: 30 A 2400 OHMS.

CONSULTE EL BOLETIN EMERSON CLIMATE TECHNOLOGIES, INC. AE #10-1264.

EL MODULO TIENE UNA DEMORA DE DOS MINUTOS ANTES DE RESTABLECERSE, EN CASO DE QUE SE DISPARE EL PROTECTOR O SE PIERDA LA ENERGIA EN EL MODULO.

**Wiring Diagram 2177 (Left Side)**



## PART WINDING START CONNECTED

CONTROL CIRCUIT VOLTAGE  
TENSION DU CIRCUIT DE CONTROLE  
VOLTAGE DEL CIRCUITO DE CONTROL

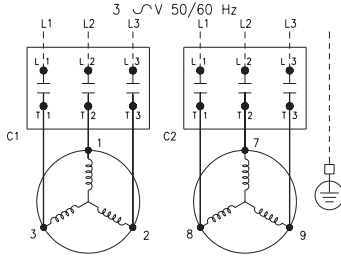
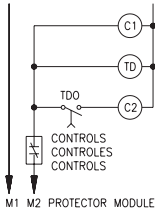

## ACROSS THE LINE CONNECTED

7-06 052-2177-00

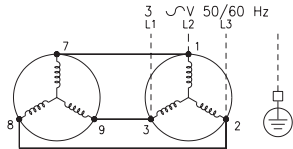

USE COPPER CONDUCTORS ONLY.  
USE MINIMUM 75 °C (167 °F) WIRE FOR AMPACITY DETERMINATION.  
USE THIS EQUIPMENT ON A GROUNDED SYSTEM ONLY.  
PRIMARY SINGLE PHASE FAILURE PROTECTION IS PROVIDED.  
PROTECTOR MODULE AND OPTIONAL CRANKCASE HEATER, FAN, OR CAPACITY CONTROL VALVE(S), MUST BE CONNECTED ONLY TO THEIR RATED VOLTAGE.  
OVERCURRENT PROTECTION DEVICE RATING AND TYPE MUST BE IN ACCORDANCE WITH REGULATORY AGENCY END PRODUCT APPROVALS—SEE SYSTEM NAMEPLATE.

UTILISER UNIQUEMENT DES CONDUCTEURS EN COUVRE.  
UTILISER CET EQUIPEMENT UNIQUEMENT AVEC UN SYSTEME MIS A LA MASSE.  
UTILISER UN FIL DE 75 °C (167 °F) MINIMUM POUR DETERMINER LE COURANT ADMISSIBLE.  
LA PROTECTION CONTRE LES DEFAILLANCES PRIMAIRES A PHASE UNIQUE EST FOURNIE.  
PROTECTION INTERNE DU MOTEUR — ATTENDRE SUFFISAMMENT DE TEMPS AVANT LA REINITIALISATION.  
LORSQUE LE RECHAUFFEUR DU CARTER MOTEUR EST UTILISE, IL DOIT ETRE RACCORDE UNIQUEMENT A SA TENSION NOMINALE.  
LA VALEUR NOMINALE ET LE TYPE DU DISPOSITIF DE PROTECTION CONTRE LA SURINTENSITE DOIVENT ETRE CONFORMES AUX APPROBATIONS DE PRODUIT FINAL DES AGENCES DE RELEMENTATION — VOIR LA PLAQUE SIGNALETIQUE DU SYSTEME.

UTILICE UNICAMENTE CONDUCTORES DE COBRE.  
USE ESTE EQUIPO UNICAMENTE EN UN SISTEMA CON TIERRAS.  
UTILICE CABLE CON UN MINIMO DE 75 °C (167 °F) PARA LA DETERMINACION DE LA CAPACIDAD EN AMPERES.  
INCLUYE PROTECCION PRIMARIA CONTRA FALLAS MONOFASICAS.  
PROTECCION INTERNA DEL MOTOR — DEJE PASAR UNOS MOMENTOS PARA QUE SE RESTABLEZCA.  
CUANDO SE UTILICE EL CALENTADOR DEL CARTER DEBE ESTAR CONECTADO UNICAMENTE AL VOLTAJE CORRESPONDIENTE A SU CAPACIDAD.  
LA CAPACIDAD Y TIPO DEL DISPOSITIVO DE PROTECCION DE SOBRECORRIENTE DEBEN ESTAR DE CONFORMIDAD CON LO APROBADO POR LA AGENCIA REGULADORA DE PRODUCTOS FINALES — CONSULTE LA PLACA CON LOS DATOS DEL SISTEMA.

## Wiring Diagram 2177 (Right Side)

## PART WINDING START CONNECTED

CONTROL CIRCUIT VOLTAGE  
TENSION DU CIRCUIT DE CONTROLE  
VOLTAJE DEL CIRCUITO DE CONTROL

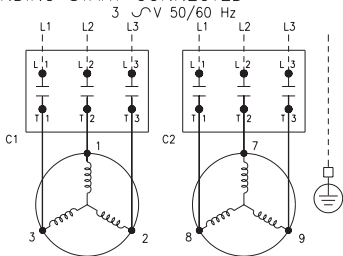
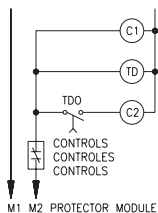

## ACROSS THE LINE CONNECTED

7-06 052-2177-00

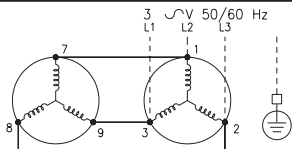

USE COPPER CONDUCTORS ONLY.  
USE MINIMUM 75 °C (167 °F) WIRE FOR AMPACITY DETERMINATION.  
USE THIS EQUIPMENT ON A GROUNDED SYSTEM ONLY.  
PRIMARY SINGLE PHASE FAILURE PROTECTION IS PROVIDED.  
PROTECTOR MODULE AND OPTIONAL CRANKCASE HEATER, FAN, OR CAPACITY CONTROL VALVE(S), MUST BE CONNECTED ONLY TO THEIR RATED VOLTAGE.  
OVERCURRENT PROTECTION DEVICE RATING AND TYPE MUST BE IN ACCORDANCE WITH REGULATORY AGENCY END PRODUCT APPROVALS—SEE SYSTEM NAMEPLATE.

UTILISER UNIQUEMENT DES CONDUCTEURS EN CUIVRE.  
UTILISER CET EQUIPEMENT UNIQUEMENT AVEC UN SYSTEME MIS A LA MASSE.  
UTILISER UN FIL DE 75 °C (167 °F) MINIMUM POUR DETERMINER LE COURANT ADMISSIBLE.  
LA PROTECTION CONTRE LES DEFAILLANCES PRIMAIRES A PHASE UNIQUE EST FOURNIE.  
PROTECTION INTERNE DU MOTEUR — ATTENDRE SUFFISAMMENT DE TEMPS AVANT LA REINITIALISATION.  
LORSQUE LE RECHAUFFEUR DU CARTER MOTEUR EST UTILISE, IL DOIT ETRE RACCORDE UNIQUEMENT A SA TENSION NOMINALE.  
LA VALEUR NOMINALE ET LE TYPE DU DISPOSITIF DE PROTECTION CONTRE LA SURINTENSITE DOIVENT ETRE CONFORMES AUX APPROBATIONS DE PRODUIT FINAL DES AGENCES DE REGLEMENTATION — VOIR LA PLAQUE SIGNALETIQUE DU SYSTEME.

UTILICE UNICAMENTE CONDUCTORES DE COBRE.  
USE ESTE EQUIPO UNICAMENTE EN UN SISTEMA CON TIERRAS.  
UTILICE CABLE CON UN MINIMO DE 75 °C (167 °F) PARA LA DETERMINACION DE LA CAPACIDAD EN AMPERES.  
INCLUYE PROTECCION PRIMARIA CONTRA FALLAS MONOFASICAS.  
PROTECCION INTERNA DEL MOTOR — DEJE PASAR UNOS MOMENTOS PARA QUE SE RESTABLEZCA.  
CUANDO SE UTILICE EL CALENTADOR DEL CARTER DEBE ESTAR CONECTADO UNICAMENTE AL VOLTAJE CORRESPONDIENTE A SU CAPACIDAD.  
LA CAPACIDAD Y TIPO DEL DISPOSITIVO DE PROTECCION DE SOBRECORRIENTE DEBEN ESTAR DE CONFORMIDAD CON LO APROBADO POR LA AGENCIA REGULADORA DE PRODUCTOS FINALES — CONSULTE LA PLACA CON LOS DATOS DEL SISTEMA.

**Discontinued**  
**Wiring Diagram 005-0492, 0637**

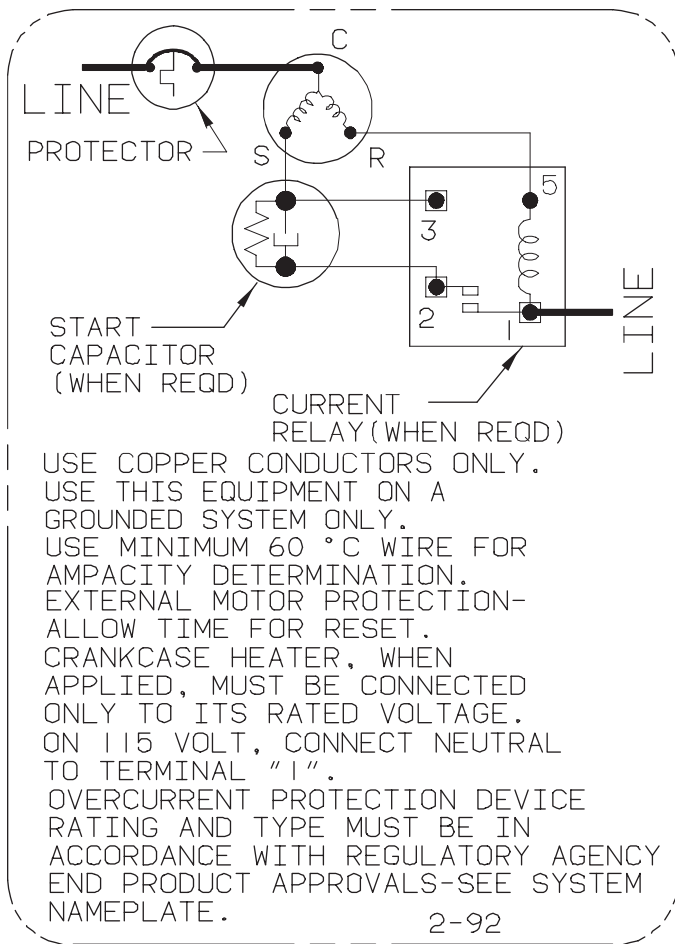

**Discontinued**  
**Wiring Diagram 005-0655, 0697**

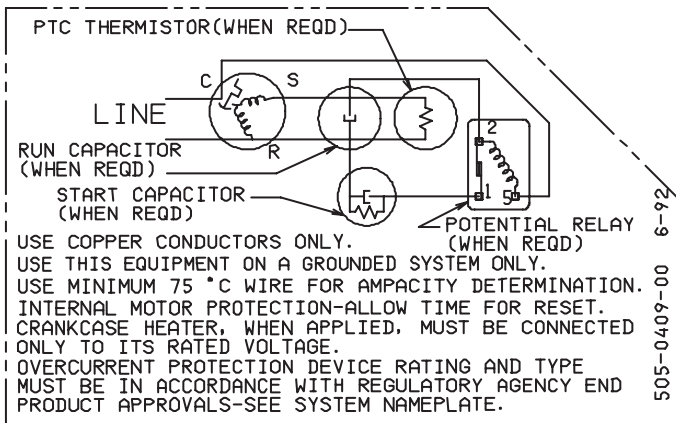

USE COPPER CONDUCTORS ONLY.  
 USE THIS EQUIPMENT ON A GROUND SYSTEM ONLY.  
 USE MINIMUM 75 °C WIRE FOR AMPACITY DETERMINATION.  
 INTERNAL MOTOR PROTECTION-ALLOW TIME FOR RESET.  
 CRANKCASE HEATER, WHEN APPLIED, MUST BE CONNECTED ONLY TO ITS RATED VOLTAGE.  
 OVERCURRENT PROTECTION DEVICE RATING AND TYPE MUST BE IN ACCORDANCE WITH REGULATORY AGENCY END PRODUCT APPROVALS-SEE SYSTEM NAMEPLATE.

**Discontinued**  
**Wiring Diagram 005-0678-00, 005-0679-00**

USE COPPER CONDUCTORS ONLY.  
 USE THIS EQUIPMENT ON A  
 GROUNDED SYSTEM ONLY.  
 USE MINIMUM 75 °C WIRE FOR  
 AMPACITY DETERMINATION. INTERNAL MOTOR  
 PROTECTION-ALLOW TIME FOR RESET.  
 OVERCURRENT PROTECTION DEVICE RATING  
 AND TYPE MUST BE IN ACCORDANCE  
 WITH REGULATORY AGENCY END PRODUCT  
 APPROVALS-SEE SYSTEM NAMEPLATE.  
 EXTERNAL THERMOSTAT, WHEN PROVIDED  
 MUST BE FIELD CONNECTED TO 24 VOLT  
 COMPRESSOR CONTROL CIRCUIT.

005-0706-00  
 X  
 X

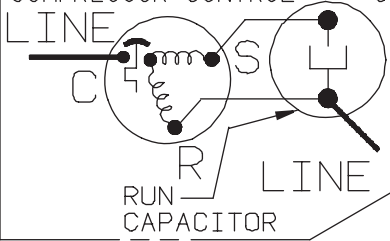

**Discontinued**  
**Wiring Diagram 005-0706**

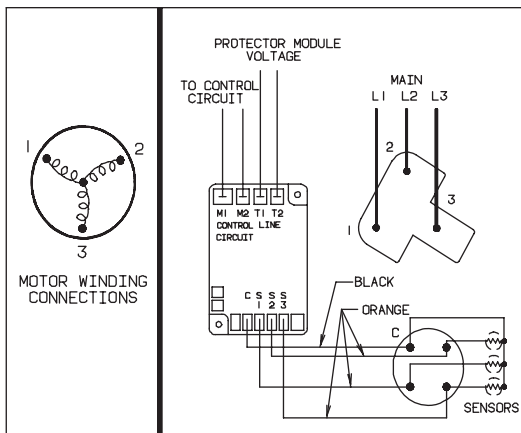

WHEN CHECKING SOLID STATE MODULE :

USE OHMMETER ONLY (6 VOLTS MAXIMUM) TO CHECK SENSOR RESISTANCE. DO NOT SHORT ACROSS THE TERMINALS.

RESISTANCE ACROSS EACH MOTOR SENSOR SHOULD BE APPROXIMATELY 500 TO 2400 OHMS WITH A MOTOR TEMPERATURE BELOW 60 °C.

MODULE HAS TWO MINUTE TIME DELAY BEFORE RESET IN EVENT OF PROTECTOR TRIP OR LOSS OF MODULE POWER.

USE COPPER CONDUCTORS ONLY.

USE MINIMUM 75 °C WIRE FOR AMPACITY DETERMINATION.

USE THIS EQUIPMENT ON A GROUNDED SYSTEM ONLY.

PRIMARY SINGLE PHASE FAILURE PROTECTION IS PROVIDED.

PROTECTOR MODULE AND OPTIONAL CRANKCASE HEATER MUST BE CONNECTED ONLY TO THEIR RATED VOLTAGE.

OVERCURRENT PROTECTION DEVICE RATING AND TYPE MUST BE IN ACCORDANCE WITH REGULATORY AGENCY END PRODUCT APPROVALS-SEE SYSTEM NAMEPLATE.

9-93

052-0716-00

**Discontinued**  
**Wiring Diagram 0716**

**This page is left blank intentionally.**

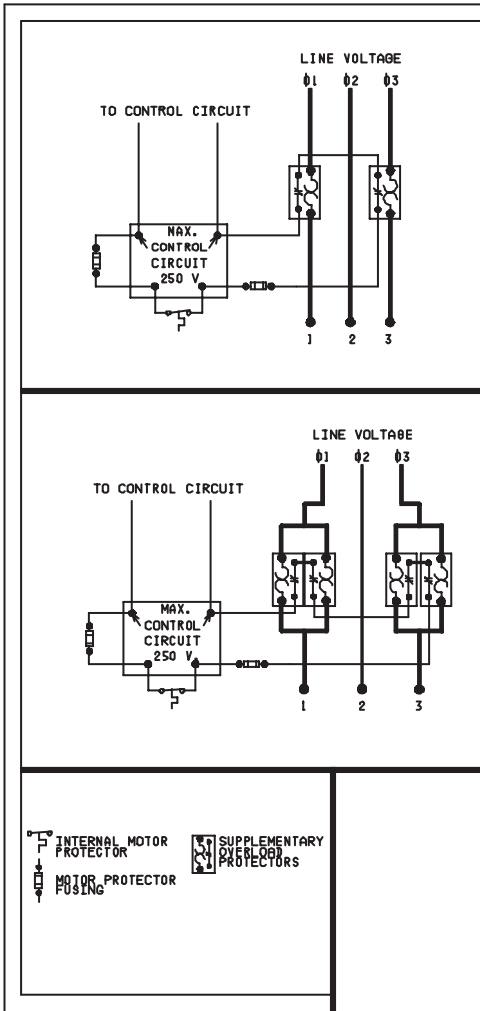

**Discontinued**  
**Wiring Diagram 0748 (Left Side)**



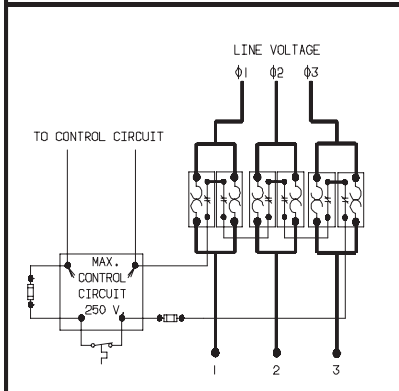
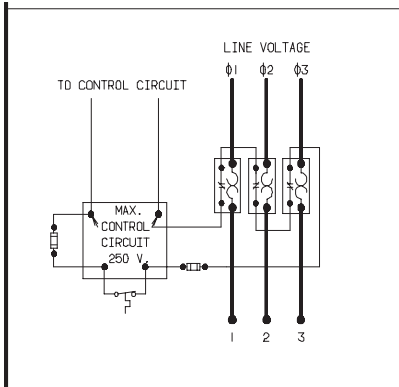

USE COPPER CONDUCTORS ONLY.  
 USE MINIMUM 75 °C WIRE FOR AMPACITY DETERMINATION.  
 USE THIS EQUIPMENT ON A GROUNDED SYSTEM ONLY.  
 PRIMARY SINGLE PHASE FAILURE PROTECTION IS PROVIDED.  
 OVERCURRENT PROTECTION DEVICE RATING AND TYPE MUST  
 BE IN ACCORDANCE WITH REGULATORY AGENCY END PRODUCT  
 APPROVALS-SEE SYSTEM NAMEPLATE.  
 COMPRESSOR HAS INTERNAL/EXTERNAL MOTOR PROTECTION-  
 ALLOW TIME FOR RESET  
 OVERLOAD PROTECTOR, AND OPTIONAL CRANKCASE HEATER  
 OR CAPACITY CONTROL VALVE(S) MUST BE CONNECTED  
 ONLY TO THEIR RATED VOLTAGE.  
 MAXIMUM MOTOR THERMOSTAT FUSE SIZE:  
 24 VOLTS-5 AMPS      200-240 VOLTS-2 AMPS  
 100-120 VOLTS-4 AMPS      9-93    062-0748-00

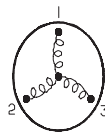

MOTOR WINDING CONNECTIONS

## Discontinued Wiring Diagram 0748 (Right Side)

TWO SPEED

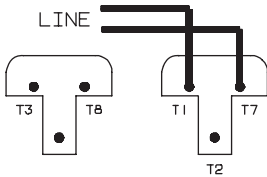

LOW SPEED

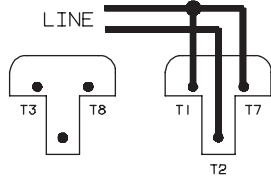

HIGH SPEED

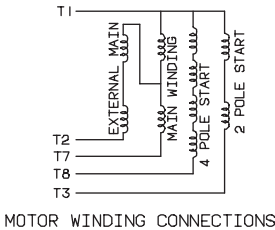

MOTOR WINDING CONNECTIONS

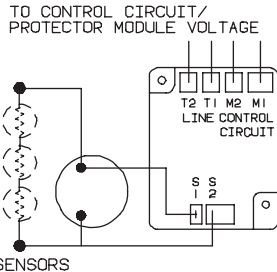

SENSORS

USE COPPER CONDUCTORS ONLY.  
 USE MINIMUM 75 °C WIRE FOR AMPACITY DETERMINATION.  
 USE THIS EQUIPMENT ON A GROUND SYSTEM ONLY.  
 PROTECTOR MODULE AND OPTIONAL CRANKCASE HEATER MUST BE  
 CONNECTED ONLY TO THEIR RATED VOLTAGE.  
 OVERCURRENT PROTECTION DEVICE RATING AND TYPE MUST BE IN  
 ACCORDANCE WITH REGULATORY AGENCY END PRODUCT APPROVALS-SEE  
 SYSTEM NAMEPLATE.  
 SEE SYSTEM MANUFACTURER'S WIRING DIAGRAM FOR START  
 COMPONENT CONNECTIONS. 5-95 052-0751-00

**Discontinued**  
**Wiring Diagram 0751**

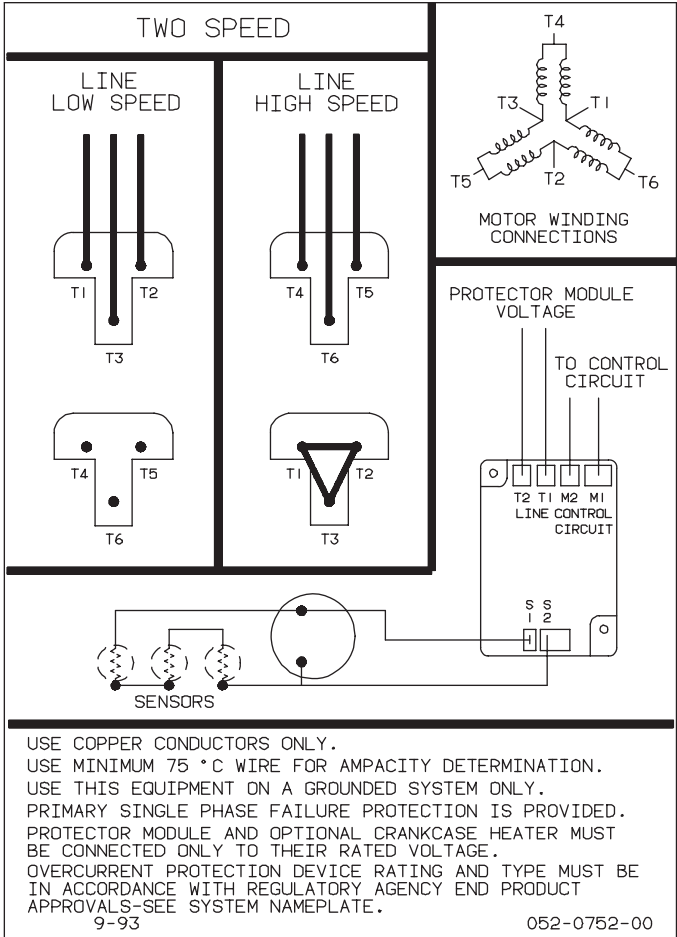

**Discontinued**  
**Wiring Diagram 0752**

USE COPPER CONDUCTORS ONLY.  
 USE THIS EQUIPMENT ON A GROUND  
 SYSTEM ONLY. USE MINIMUM 75 °C  
 WIRE FOR AMPACITY DETERMINATION.  
 INTERNAL MOTOR CONNECTION—ALLOW  
 TIME FOR RESET. OVERCURRENT PRO-  
 TECTION DEVICE RATING AND TYPE MUST  
 BE IN ACCORDANCE WITH REGULATORY AGENCY  
 END PRODUCT APPROVALS - SEE SYSTEM NAME-  
 PLATE. EXTERNAL THERMOSTAT, WHEN PROVIDED  
 MUST BE FIELD CONNECTED TO 24 VOLT  
 COMPRESSOR CONTROL CIRCUIT.

052-0756-00

10-93

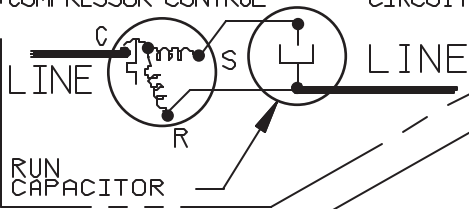

**Discontinued  
 Wiring Diagram 0756**

## DELTA CONNECTED

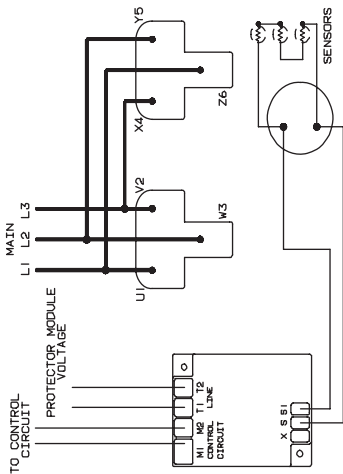

## STAR CONNECTED

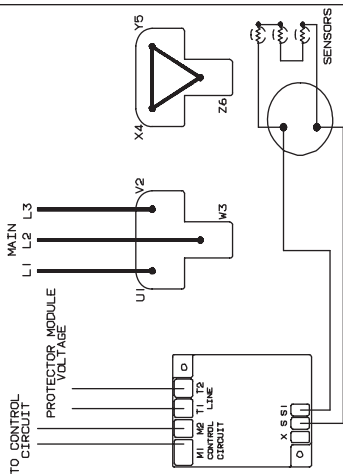

WHEN CHECKING SOLID STATE MODULE:  
USE OHMMETER ONLY (6 VOLTS MAXIMUM) TO  
CHECK SENSOR RESISTANCE. DO NOT SHORT  
ACROSS THE TERMINALS.

RESISTANCE ACROSS MOTOR SENSORS SHOULD  
BE APPROXIMATELY 1500 TO 7800 OHMS  
WITH A MOTOR TEMPERATURE BELOW 60 °C.  
MODULE HAS FOUR MINUTE TIME  
DELAY BEFORE RESET IN EVENT  
PROTECTOR TRIP OR LOSS OF MODULE POWER.

USE COPPER CONDUCTORS ONLY.  
USE MINIMUM 75 °C WIRE FOR  
AMPACITY DETERMINATION.  
USE THIS EQUIPMENT ON A GROUNDED  
SYSTEM ONLY.

PRIMARY SINGLE PHASE FAILURE  
PROTECTION IS PROVIDED.  
PROTECTOR MODULE AND OPTIONAL  
CRANKCASE HEATER MUST BE CONNECTED  
ONLY TO THEIR RATED VOLTAGE.  
OVERCURRENT PROTECTION DEVICE  
RATING AND TYPE MUST BE IN  
ACCORDANCE WITH REGULATORY AGENCY  
END PRODUCT APPROVALS-SEE SYSTEM  
NAMEPLATE.



MOTOR WINDING  
CONNECTIONS

9-93

062-0757-00

Discontinued  
Wiring Diagram 0757

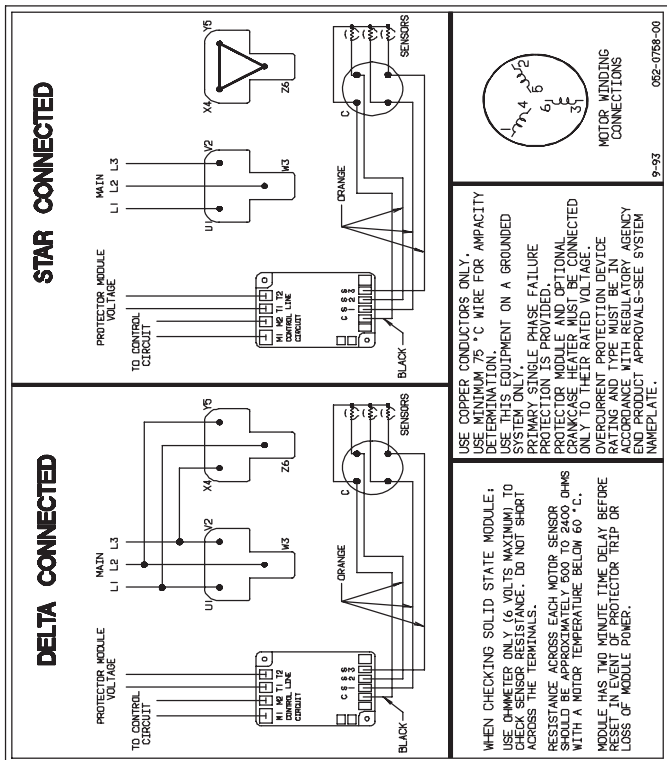

## Discontinued Wiring Diagram 0758

USE COPPER CONDUCTORS ONLY.  
 USE 60 °C WIRE FOR AMPACITY DETERMINATION.  
 USE THIS EQUIPMENT ON A GROUNDED SYSTEM ONLY.

PRIMARY SINGLE PHASE FAILURE PROTECTION IS PROVIDED.

CAPACITY CONTROL VALVE(S), FAN(S), CRANKCASE HEATER(S), WHEN PROVIDED, MUST BE FIELD CONNECTED TO SEPARATE VOLTAGE SOURCE.

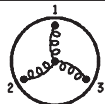

INTERNAL MOTOR WINDING CONNECTION

### ELECTRICAL SYMBOL LEGEND

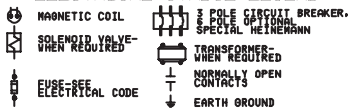

### ACROSS THE LINE CONNECTED

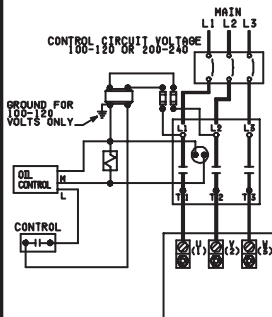

9-89 052-0759-00

Discontinued  
 Wiring Diagram 0759

WHEN CHECKING SOLID STATE MODULE:  
 USE OHMMETER ONLY (6 VOLTS MAXIMUM.) TO CHECK  
 SENSOR RESISTANCE. DO NOT SHORT ACROSS THE  
 TERMINALS.

RESISTANCE ACROSS EACH MOTOR SENSOR SHOULD BE  
 APPROXIMATELY 500 TO 2400 OHMS WITH A MOTOR  
 TEMPERATURE BELOW 60 °C.

MODULE HAS TWO MINUTE TIME DELAY BEFORE RESET  
 IN EVENT OF PROTECTOR TRIP OR LOSS OF MODULE  
 POWER.

USE COPPER CONDUCTORS ONLY.

USE MINIMUM 75 °C WIRE FOR AMPACITY  
 DETERMINATION.

USE THIS EQUIPMENT ON A GROUNDED SYSTEM ONLY.  
 PRIMARY SINGLE PHASE FAILURE PROTECTION  
 IS PROVIDED.

PROTECTOR MODULE AND OPTIONAL CRANKCASE  
 HEATER, FAN OR CAPACITY CONTROL VALVE(S)  
 MUST BE CONNECTED ONLY TO THEIR RATED  
 VOLTAGE.

OVERCURRENT PROTECTION DEVICE RATING AND  
 TYPE MUST BE IN ACCORDANCE WITH REGULATORY  
 AGENCY END PRODUCT APPROVALS-SEE SYSTEM  
 NAMEPLATE.

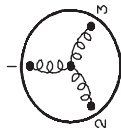

MOTOR WINDING CONNECTIONS

## ACROSS THE LINE CONNECTED

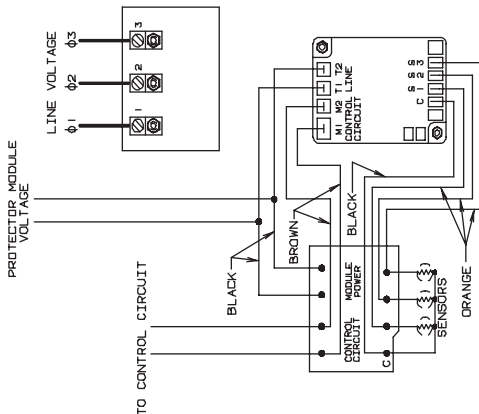

## Discontinued Wiring Diagram 0760



**This page is left blank intentionally.**

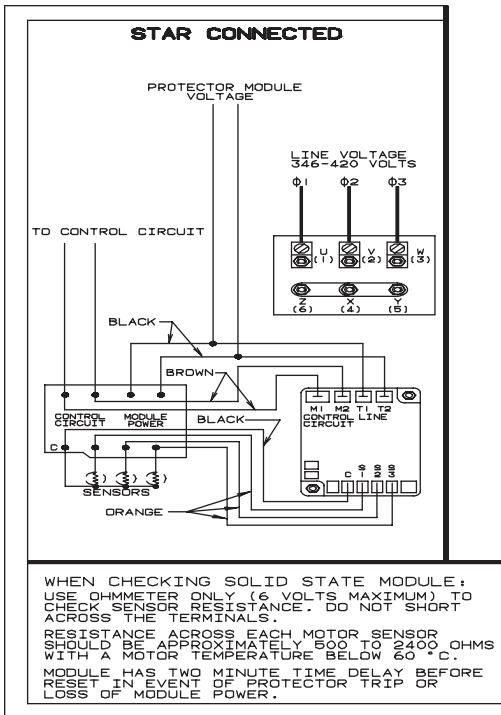

**Discontinued**  
**Wiring Diagram 0762 (Left Side)**

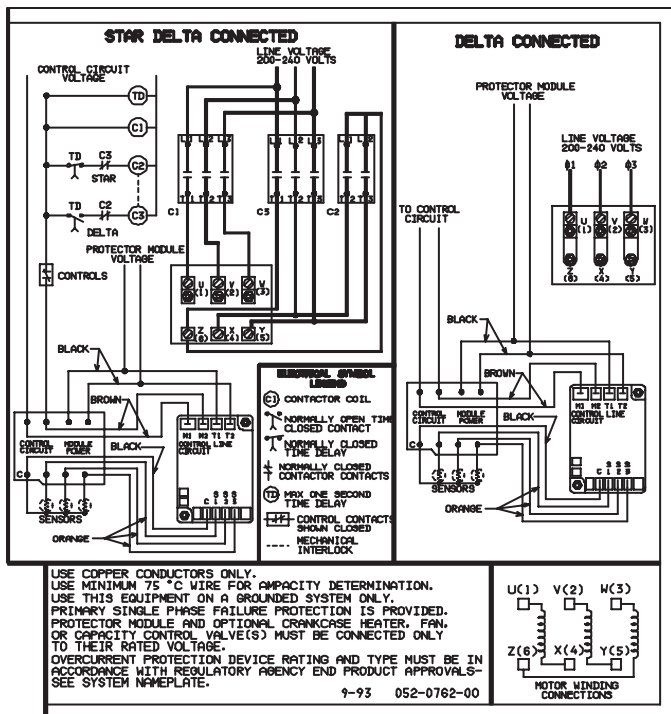

**Discontinued**  
**Wiring Diagram 0762 (Right Side)**

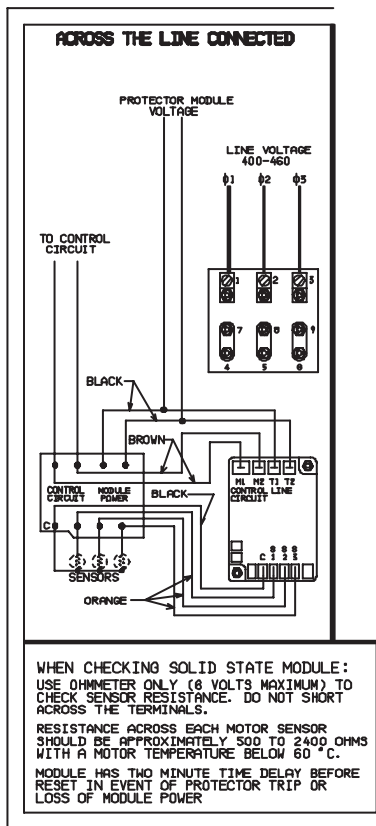

**Discontinued**  
**Wiring Diagram 0763 (Left Side)**

### PART WINDING START CONNECTED

### ACROSS THE LINE CONNECTED

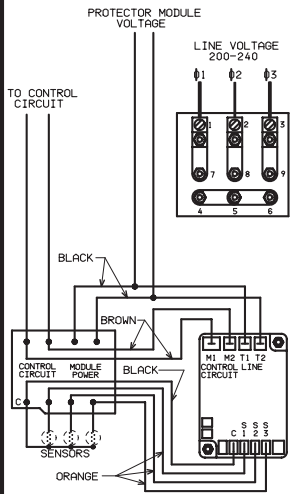
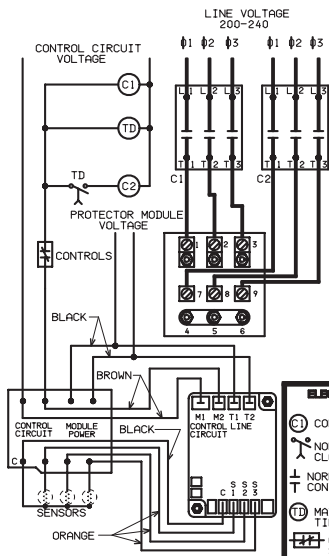

- ELECTRICAL SYMBOL LEGEND**
- (C) CONTACTOR COIL
  - ⏏ NORMALLY OPEN TIME CLOSED CONTACT
  - ⏏ NORMALLY OPEN CONTACTOR CONTACTS
  - (TD) MAX ONE SECOND TIME DELAY
  - ⏏ CONTROL CONTACTS SHOWN CLOSED

USE COPPER CONDUCTORS ONLY.  
 USE MINIMUM 75 °C WIRE FOR AMPACITY DETERMINATION.  
 USE THIS EQUIPMENT ON A GROUNDING SYSTEM ONLY.  
 PRIMARY SINGLE PHASE FAILURE PROTECTION IS PROVIDED.  
 PROTECTOR MODULE AND OPTIONAL CRANKCASE HEATER, FAN,  
 OR CAPACITY CONTROL VALVE(S) MUST BE CONNECTED ONLY  
 TO THEIR RATED VOLTAGE.  
 OVERCURRENT PROTECTION DEVICE RATING AND TYPE MUST BE  
 IN ACCORDANCE WITH REGULATORY AGENCY END PRODUCT  
 APPROVALS-SEE SYSTEM NAMEPLATE.

9-93 052-0763-00

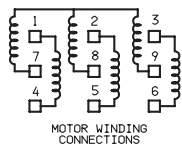

**Discontinued**  
**Wiring Diagram 0763 (Right Side)**

### PART WINDING START CONNECTED

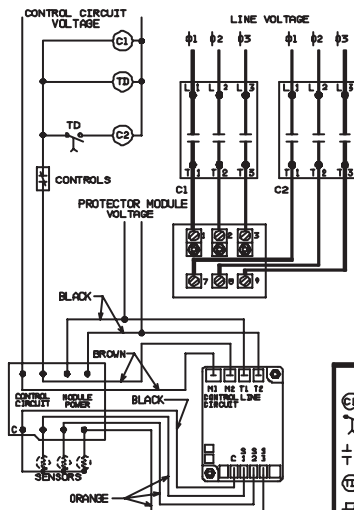

ELECTRICAL SYMBOL LEGEND	
(C1)	CONTACTOR COIL
	NORMALLY OPEN TIME CLOSED CONTACT
	NORMALLY OPEN CONTACTOR CONTACTS
(TD)	MAX ONE SECOND TIME DELAY
	CONTROL CONTACTS SHOWN CLOSED

WHEN CHECKING SOLID STATE MODULE:  
USE OHMMETER ONLY (6 VOLTS MAXIMUM) TO  
CHECK SENSOR RESISTANCE. DO NOT SHORT  
ACROSS THE TERMINALS.

RESISTANCE ACROSS EACH MOTOR SENSOR  
SHOULD BE APPROXIMATELY 500 TO 2400 OHMS  
WITH A MOTOR TEMPERATURE BELOW 60 °C.

MODULE HAS TWO MINUTE TIME DELAY BEFORE  
RESET IN EVENT OF PROTECTOR TRIP OR  
LOSS OF MODULE POWER

**Discontinued**  
**Wiring Diagram 0765 (Left Side)**

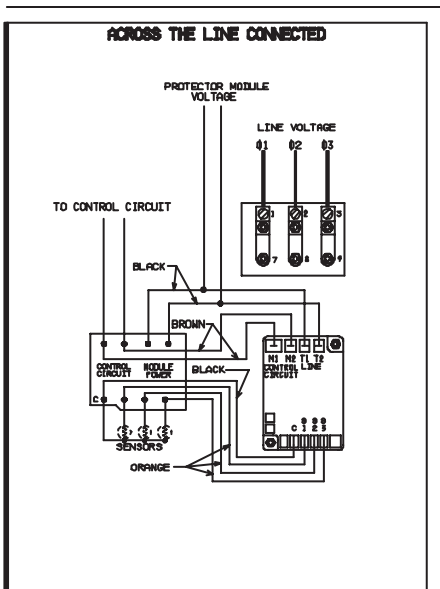

USE COPPER CONDUCTORS ONLY.  
 USE MINIMUM 75 °C WIRE FOR AMPACITY DETERMINATION.  
 USE THIS EQUIPMENT ON A GROUNDING SYSTEM ONLY.  
 PRIMARY SINGLE PHASE FAILURE PROTECTION IS PROVIDED.  
 PROTECTOR MODULE AND OPTIONAL CRANKCASE HEATER, FAN,  
 OR CAPACITY CONTROL VALVE(S), MUST BE CONNECTED ONLY  
 TO THEIR RATED VOLTAGE  
 OVERCURRENT PROTECTION DEVICE RATING AND TYPE MUST BE IN  
 ACCORDANCE WITH REGULATORY AGENCY END PRODUCT APPROVALS—  
 SEE SYSTEM NAMEPLATE.

9-93 052-0765-00

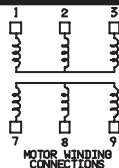

**Discontinued**  
**Wiring Diagram 0765 (Right Side)**

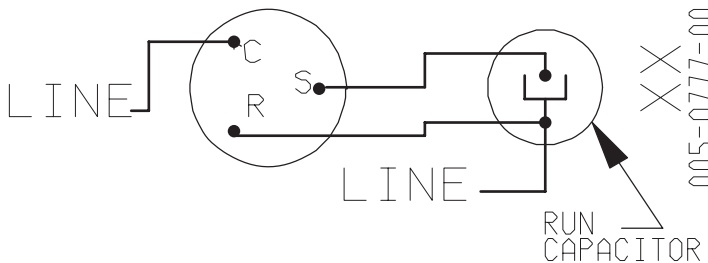

USE COPPER CONDUCTORS ONLY.  
 USE THIS EQUIPMENT ON A  
 GROUNDED SYSTEM ONLY  
 INTERNAL MOTOR PROTECTION-  
 ALLOW TIME FOR RESET.  
 USE MINIMUM 60°C WIRE FOR

△ AMPACITY DETERMINATION  
 FUSING OR CIRCUIT BREAKERS  
 WHERE APPLICABLE. MUST  
 BE IN ACCORDANCE WITH  
 ALL ELECTRICAL CODES.

7-91

**Discontinued**  
**Wiring Diagram 005-0777**



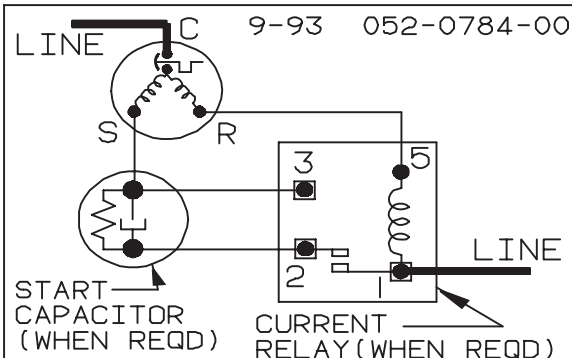

USE COPPER CONDUCTORS ONLY.  
 USE THIS EQUIPMENT ON A GROUND  
 ED SYSTEM ONLY.  
 USE MINIMUM 75 °C WIRE FOR  
 AMPACITY DETERMINATION.  
 INTERNAL MOTOR PROTECTION-  
 ALLOW TIME FOR RESET  
 CRANKCASE HEATER, WHEN  
 APPLIED, MUST BE CONNECTED  
 ONLY TO ITS RATED VOLTAGE.  
 ON 115 VOLT, CONNECT NEUTRAL  
 TO TERMINAL "1".  
 OVERCURRENT PROTECTION DEVICE  
 RATING AND TYPE MUST BE IN  
 ACCORDANCE WITH REGULATORY  
 AGENCY END PRODUCT APPROVALS-  
 SEE SYSTEM NAMEPLATE.

**Discontinued**  
**Wiring Diagram 0784**

USE COPPER CONDUCTORS ONLY. USE THIS EQUIPMENT ON A GROUNDING SYSTEM ONLY. USE MINIMUM 75°C WIRE FOR AMPACITY DETERMINATION. INTERNAL MOTOR PROTECTION-ALLOW TIME FOR RESET. OVERCURRENT PROTECTION DEVICE RATING AND TYPE MUST BE IN ACCORDANCE WITH REGULATORY AGENCY END PRODUCT APPROVALS-SEE SYSTEM NAMEPLATE.

005-0788-00

XX

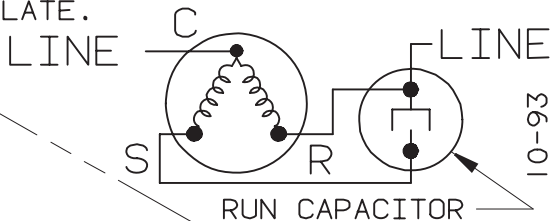

10-93

**Discontinued**  
**Wiring Diagram 005-0788**

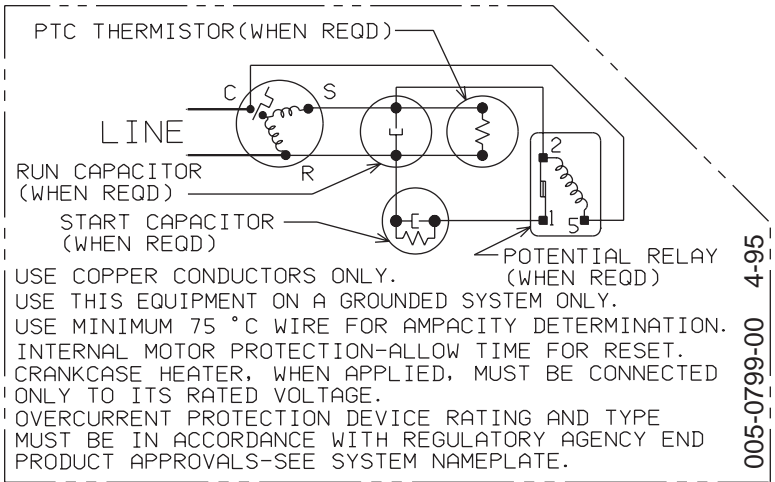

**Discontinued**  
**Wiring Diagram 005-0799-00, 005-0800-00**

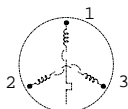
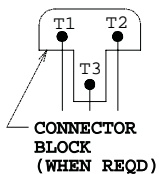

**USE COPPER CONDUCTORS  
ONLY.**

**USE THIS EQUIPMENT ON A  
GROUNDED SYSTEM ONLY.**

**USE MINIMUM 75 C WIRE FOR  
AMPACITY DETERMINATION.**

**PRIMARY SINGLE PHASE FAILURE  
PROTECTION IS PROVIDED.**

**INTERNAL MOTOR PROTECTION-ALLOW  
TIME FOR RESET.**

**CRANKCASE HEATER, WHEN APPLIED,  
MUST BE CONNECTED ONLY TO ITS  
RATED VOLTAGE.**

**OVERCURRENT PROTECTION DEVICE  
RATING AND TYPE MUST BE IN  
ACCORDANCE WITH REGULATORY AGENCY  
END PRODUCT APPROVALS- SEE SYSTEM  
NAMEPLATE.**

005-0800-01 4-95

**Discontinued  
Wiring Diagram 005-0800-01**

## DELTA CONNECTED

FIELD CONNECTIONS

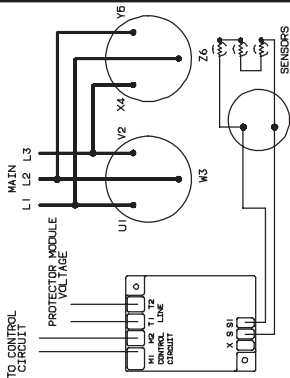

## STAR CONNECTED

FIELD CONNECTIONS

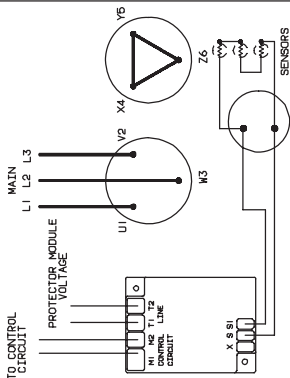

WHEN CHECKING SOLID STATE MODULE:  
USE OHMMETER ONLY (6 VOLTS MAXIMUM). TO CHECK SENSOR RESISTANCE. DO NOT SHORT ACROSS THE TERMINALS.

RESISTANCE ACROSS MOTOR SENSORS SHOULD BE APPROXIMATELY 1500 TO 7800 OHMS WITH A MOTOR TEMPERATURE BELOW 60 °C.  
MODULE HAS FOUR MINUTE TIME DELAY BEFORE RESET IN EVENT OF PROTECTOR TRIP OR LOSS OF MODULE POWER

USE COPPER CONDUCTORS ONLY.  
USE MINIMUM 75 °C WIRE FOR AMPACITY DETERMINATION.  
USE THIS EQUIPMENT ON A GROUNDED SYSTEM ONLY.  
PRIMARY SINGLE PHASE FAILURE PROTECTION IS PROVIDED.  
PROTECTOR MODULE AND OPTIONAL CRANKCASE HEATER MUST BE CONNECTED ONLY TO THEIR RATED VOLTAGE.  
OVERCURRENT PROTECTION DEVICE RATING AND TYPE MUST BE IN ACCORDANCE WITH REGULATIONS OR AGENCY LISTED PRODUCT APPROVALS-SEE SYSTEM NAMEPLATE.

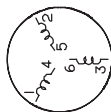

MOTOR WINDING CONNECTIONS

9-93 052-0801-00

Discontinued  
Wiring Diagram 0801

### DELTA CONNECTED

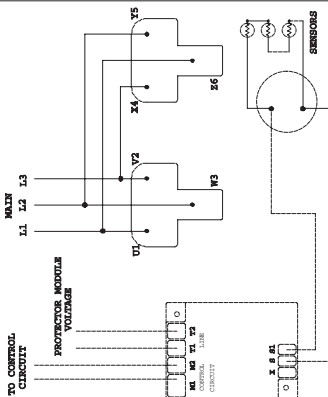

### STAR CONNECTED

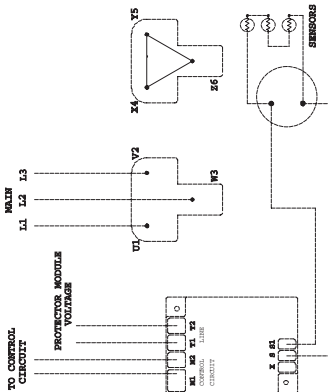

WHEN CHECKING SOLID STATE MODULE:  
USE OHMMETER ONLY (6 VOLTS MAXIMUM) TO  
CHECK SENSOR RESISTANCE. DO NOT SHORT  
ACROSS THE TERMINALS.

RESISTANCE ACROSS MOTOR SENSORS SHOULD  
BE APPROXIMATELY 1500 TO 7800 OHMS  
WITH A MOTOR TEMPERATURE BELOW 60 C.

USE COPPER CONDUCTORS ONLY.  
USE MINIMUM 75 C WIRE FOR  
AMPACITY DETERMINATION.  
USE THIS EQUIPMENT ON A GROUND  
SYSTEM ONLY.

PRIMARY SINGLE PHASE FAILURE  
PROTECTION IS PROVIDED.  
PROTECTOR MODULE AND OPTIONAL  
CRANKCASE HEATER MUST BE CONNECTED  
ONLY TO THEIR RATED VOLTAGE.  
OVERCURRENT PROTECTION DEVICE  
RATING AND TYPE MUST BE IN  
ACCORDANCE WITH REGULATORY  
AGENCY END PRODUCT APPROVALS-  
SEE SYSTEM NAMEPLATE.



MOTOR WINDING  
CONNECTIONS

9-93 052-0811-00

Discontinued  
Wiring Diagram 0811

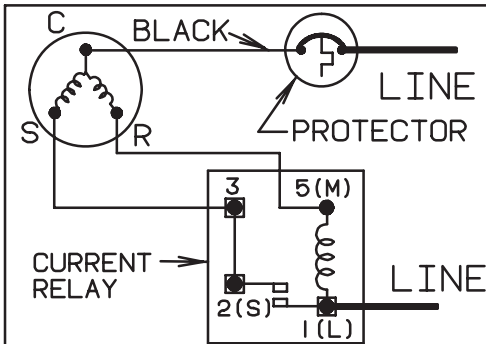

USE COPPER CONDUCTORS ONLY.  
 USE THIS EQUIPMENT ON A  
 GROUNDED SYSTEM ONLY.  
 USE MINIMUM 75 °C WIRE FOR  
 AMPACITY DETERMINATION.  
 CRANKCASE HEATER, WHEN  
 APPLIED, MUST BE CONNECTED  
 ONLY TO ITS RATED VOLTAGE.  
 CONNECT NEUTRAL TO  
 TERMINAL "1(L)".  
 EXTERNAL MOTOR PROTECTION  
 -ALLOW TIME FOR RESET.  
 OVERCURRENT PROTECTION DEVICE  
 RATING AND TYPE MUST BE IN  
 ACCORDANCE WITH REGULATORY  
 AGENCY END PRODUCT APPROVALS-  
 SEE SYSTEM NAMEPLATE.

9-93 052-0813-00

**Discontinued**  
**Wiring Diagram 0813**

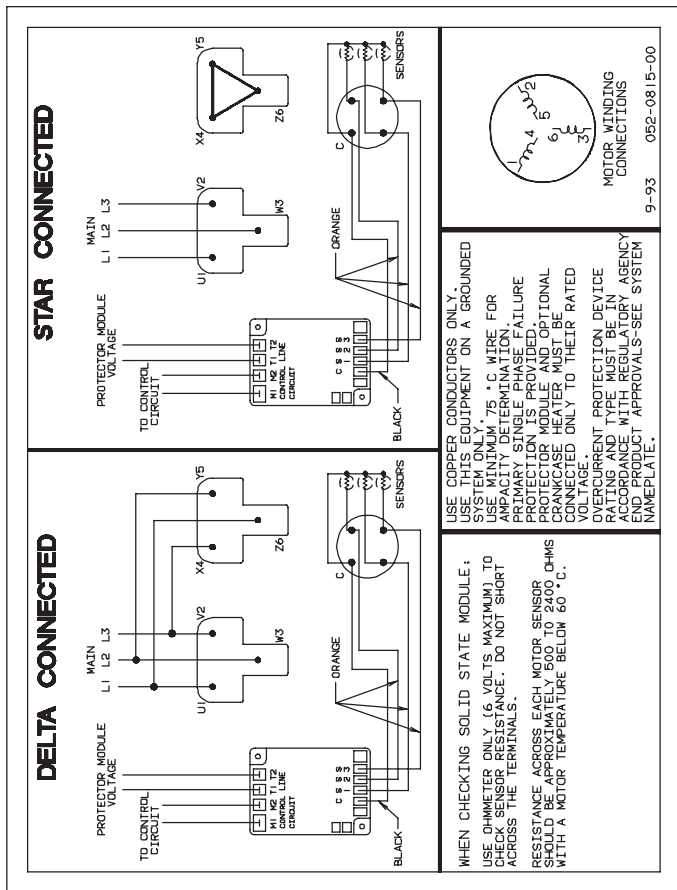

## Discontinued Wiring Diagram 0815



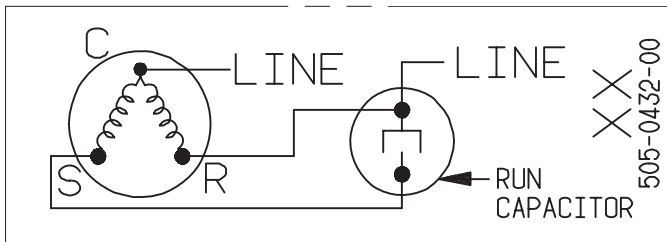

USE COPPER CONDUCTORS ONLY. USE THIS EQUIPMENT ON A GROUNDED SYSTEM ONLY. USE MINIMUM 60°C WIRE FOR AMPACITY DETERMINATION. INTERNAL MOTOR PROTECTION-ALLOW TIME FOR RESET. OVERCURRENT PROTECTION DEVICE RATING AND TYPE MUST BE IN ACCORDANCE WITH REGULATORY AGENCY END PRODUCT APPROVALS-SEE SYSTEM NAMEPLATE.

10-93

**Discontinued**  
**Wiring Diagram 005-0819**

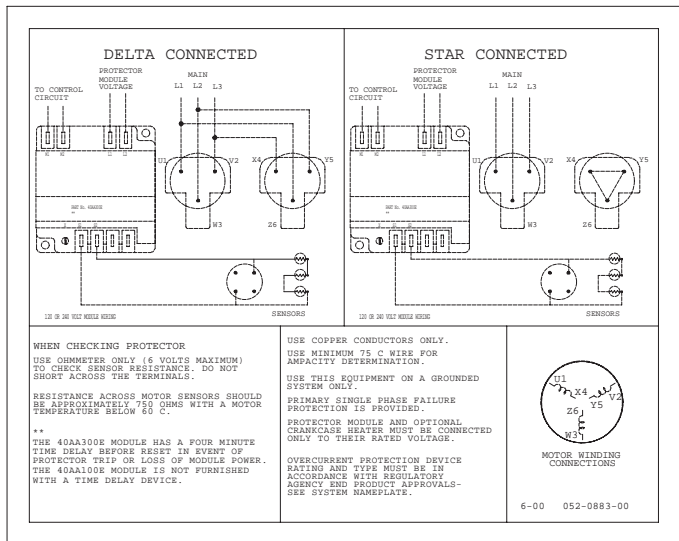

**Discontinued**  
**Wiring Diagram 0823**

## DELTA CONNECTED FIELD CONNECTIONS

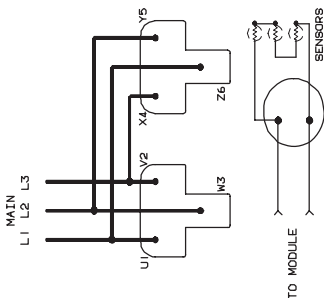

## STAR CONNECTED FIELD CONNECTIONS

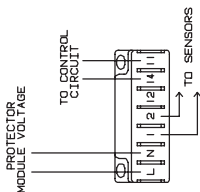
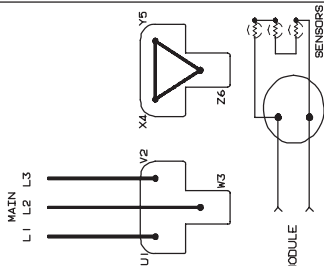

WHEN CHECKING PROTECTOR  
USE OHMMETER ONLY (2.5 VOLTS MAXIMUM)  
TO CHECK SENSOR RESISTANCE. DO NOT  
SHORT ACROSS THE TERMINALS.  
RESISTANCE ACROSS MOTOR SENSORS SHOULD  
BE APPROXIMATELY 75 OHMS WITH A MOTOR  
TEMPERATURE BELOW 60 °C.

USE COPPER CONDUCTORS ONLY.  
USE MINIMUM 75 °C WIRE FOR AMPACITY  
DETERMINATION.  
USE THIS EQUIPMENT ON A GROUNDED  
SYSTEM ONLY.  
PRIMARY SINGLE PHASE FAILURE  
PROTECTION IS PROVIDED.  
PROTECTOR MODULE AND OPTIONAL  
CRANKCASE HEATER MUST BE CONNECTED  
ONLY TO THEIR RATED VOLTAGE.  
OVERCURRENT PROTECTION DEVICE  
RATING AND TYPE MUST BE IN  
ACCORDANCE WITH REGULATORY AGENCY  
END PRODUCT APPROVALS-SEE SYSTEM  
NAMEPLATE.



MOTOR WINDING  
CONNECTIONS

9-93 052-0824-00

Discontinued  
Wiring Diagram 0824

## DELTA CONNECTED FIELD CONNECTIONS

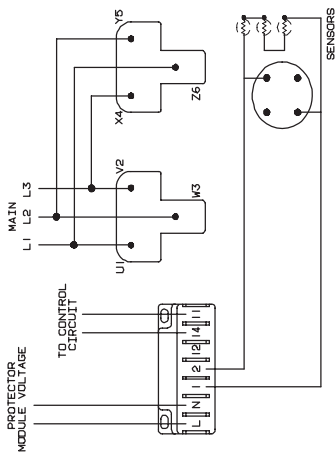

## STAR CONNECTED FIELD CONNECTIONS

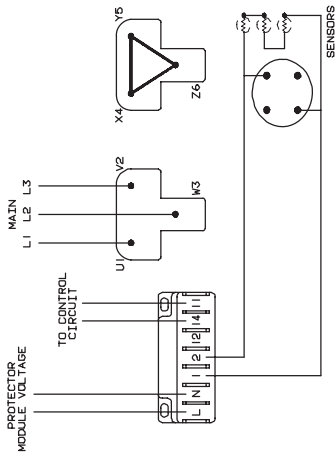

WHEN CHECKING PROTECTOR  
USE OHMMETER ONLY (2.5 VOLTS MAXIMUM) TO  
CHECK SENSOR RESISTANCE. DO NOT SHORT  
ACROSS THE TERMINALS.

RESISTANCE ACROSS MOTOR SENSORS SHOULD  
BE APPROXIMATELY 750 OHMS WITH A MOTOR  
TEMPERATURE BELOW 60 °C.

USE COPPER CONDUCTORS ONLY.  
USE MINIMUM 75 °C WIRE FOR AMPACITY  
DETERMINATION.  
USE THIS EQUIPMENT ON A GROUNDED  
SYSTEM ONLY.  
PRIMARY SINGLE PHASE FAILURE  
PROTECTION IS PROVIDED.  
PROTECTOR MODULE AND OPTIONAL  
CRANKCASE HEATER MUST BE CONNECTED  
ONLY TO THEIR RATED VOLTAGE.  
OVERCURRENT PROTECTION DEVICE  
RATING AND TYPE MUST BE IN  
ACCORDANCE WITH REGULATORY AGENCY  
END PRODUCT APPROVALS-SEE SYSTEM  
NAMEPLATE.

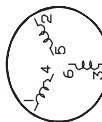

MOTOR WINDING  
CONNECTIONS

9-93

052-0825-00

Discontinued  
Wiring Diagram 0825

USE COPPER CONDUCTORS ONLY. USE THIS EQUIPMENT ON A GROUNDED SYSTEM ONLY. USE MINIMUM 75 °C WIRE FOR AMPACITY DETERMINATION. INTERNAL MOTOR PROTECTION- ALLOW TIME FOR RESET. PRIMARY SINGLE PHASE FAILURE PROTECTION IS PROVIDED. CRANKCASE HEATER, WHEN APPLIED, MUST BE CONNECTED ONLY TO ITS RATED VOLTAGE. OVERCURRENT PROTECTION DEVICE RATING AND TYPE MUST BE IN ACCORDANCE WITH REGULATORY AGENCY END PRODUCT APPROVALS -SEE SYSTEM NAMEPLATE. TO CORRECT IMPROPER MOTOR ROTATION, SWITCH ANY TWO SUPPLY LINES.

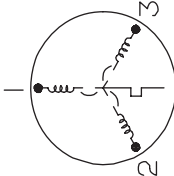
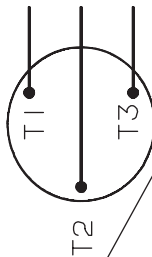

MOTOR WINDING CONNECTIONS

10-93 052-0826-00

**Discontinued  
Wiring Diagram 0826**

USE COPPER CONDUCTORS ONLY. USE THIS EQUIPMENT ON A GROUNDING SYSTEM ONLY. USE MINIMUM 75°C WIRE FOR AMPACITY DETERMINATION. INTERNAL MOTOR PROTECTION-ALLOW TIME FOR RESET. OVERCURRENT PROTECTION DEVICE RATING AND TYPE MUST BE IN ACCORDANCE WITH REGULATORY AGENCY END PRODUCT APPROVALS-SEE SYSTEM NAMEPLATE.

XX

005-0837-00

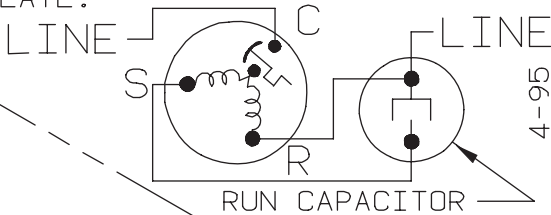

4-95

**Discontinued  
Wiring Diagram 005-0837**

USE COPPER CONDUCTORS ONLY.  
 USE THIS EQUIPMENT ON A  
 GROUNDED SYSTEM ONLY.  
 USE MINIMUM 75 °C WIRE FOR  
 AMPACITY DETERMINATION. INTERNAL MOTOR  
 PROTECTION-ALLOW TIME FOR RESET.  
 OVERCURRENT PROTECTION DEVICE RATING X  
 AND TYPE MUST BE IN ACCORDANCE X  
 WITH REGULATORY AGENCY END PRODUCT  
 APPROVALS-SEE SYSTEM NAMEPLATE.  
 EXTERNAL THERMOSTAT, WHEN PROVIDED  
 MUST BE FIELD CONNECTED TO 24 VOLT  
 COMPRESSOR CONTROL CIRCUIT.

005-0838-00

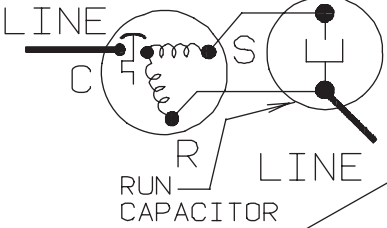

4-95

**Discontinued**  
**Wiring Diagram 005-0838**

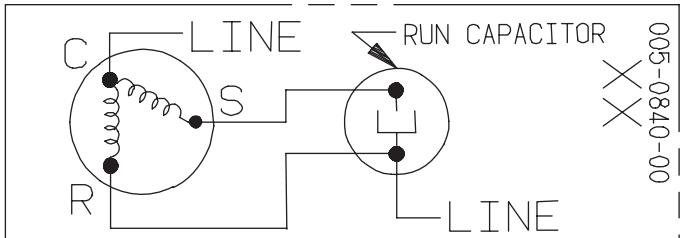

USE COPPER CONDUCTORS ONLY. USE THIS EQUIPMENT ON A GROUNDING SYSTEM ONLY. USE MINIMUM 75°C WIRE FOR AMPACITY DETERMINATION. INTERNAL MOTOR PROTECTION-ALLOW TIME FOR RESET. OVERCURRENT PROTECTION DEVICE RATING AND TYPE MUST BE IN ACCORDANCE WITH REGULATORY AGENCY END PRODUCT APPROVALS-SEE SYSTEM NAMEPLATE.

11-95

**Discontinued**  
**Wiring Diagram 005-0840**



**This page is left blank intentionally.**

### PART WINDING START CONNECTED

CONTROL CIRCUIT VOLTAGE  
TENSION DU CIRCUIT DE COMMANDE  
STEUERSTROMKREISSPANNUNG

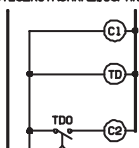

CONTROLS  
KONTROLLES  
COMMANDES

PROTECTOR MODULE VOLTAGE  
TENSION DU MODULE DU DISPOSITIF DE PROTECTION  
SCHUTZGERÄTSPANNUNG

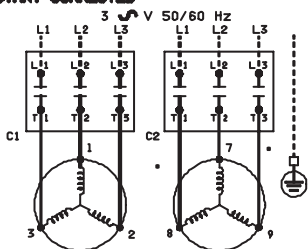
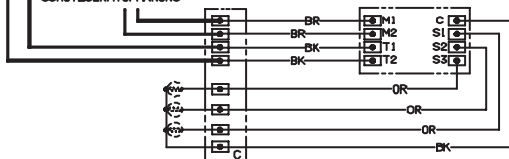

WHEN CHECKING SOLID STATE MODULE:

USE OHMMETER ONLY TO CHECK SENSOR RESISTANCE.

DO NOT SHORT ACROSS THE TERMINALS.

RESISTANCE ACROSS EACH MOTOR SENSOR SHOULD BE APPROXIMATELY 500 TO

2400 OHMS WITH A MOTOR TEMPERATURE BELOW 60 °C.

MODULE HAS TWO MINUTE TIME DELAY BEFORE RESET IN EVENT OF

PROTECTOR TRIP OR LOSS OF MODULE POWER.

LORS DE LA VERTIFICATION DU MODULE ELECTRONIQUE,

UTILISER SEULEMENT UN OHMMETRE POUR VERIFIER LA RESISTANCE

DE LA SONDE NE PAS COURT-CIRCUITER LES BORNES.

LA RESISTANCE ENTRE LES BORNES DE CHAQUE SONDE D'UN MOTEUR DEVRAIT

ETRE APPROXIMATIVEMENT DE 500 A 2400 OHMS LORSQUE LA TEMPERATURE

DU MOTEUR EST INFERIEURE A 60 °C.

LE MODULE MET DEUX MINUTES A SE REARMER S'IL MANQUE DE COURANT OU

SI LE DISPOSITIF DE PROTECTION EST DECLENCHE.

BEI PRUFUNG DES MOTORSCHUTZGERÄTES.

ZUM PRUFEN DER SENSORWIDERSTÄNDE NUR EIN OHMMETER VERWENDEN.

DIE SENSORANSCHLÜSSE DÜRFEN NICHT ÜBERBRÜCKT WERDEN

DER SENSORWIDERSTAND SOLITE CIRCA 500 BIS 2400 OHM BETRAGEN BEI

EINER MOTORTEMPERATUR UNTER 60 °C.

WENN GERÄT ABGESCHALTET ODER DIE SPANNUNGSVERSORGUNG UNTERBROCHEN

WÄR, HAT DAS SCHUTZGERÄT EINE ZEITVERZÖGERUNG VON ZWEI MINUTEN ZUM

RÜCKSCHALTEN.

**Discontinued**  
**Wiring Diagram 0841 (Left Side)**

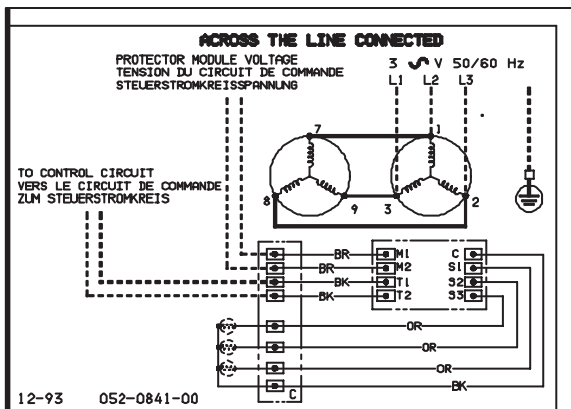

USE COPPER CONDUCTORS ONLY.

USE MINIMUM 75 °C WIRE FOR AMPACITY DETERMINATION.

USE THIS EQUIPMENT ON A GROUND SYSTEM ONLY.

PRIMARY SINGLE PHASE FAILURE PROTECTION IS PROVIDED.

PROTECTOR MODULE AND OPTIONAL CRANKCASE HEATER, FAN, OR CAPACITY CONTROL VALVE(S), MUST BE CONNECTED ONLY TO THEIR RATED VOLTAGE. OVERCURRENT PROTECTION DEVICE RATING AND TYPE MUST BE IN ACCORDANCE WITH REGULATORY AGENCY END PRODUCT APPROVALS-SEE SYSTEM NAMEPLATE.

N'UTILISER QUE DES CONDUCTEURS EN CUIVRE.

UTILISER UN FIL D'AU MOINS 75 °C POUR DETERMINER LE COURANT ADMISSIBLE.

UTILISER CE MATERIEL SEULEMENT DANS UN RESEAU MIS A LA TERRE.

PROTECTION PRIMAIRE MONOPHASEE FOURNIE

LE MODULE DU DISPOSITIF DE PROTECTION ET LE CHAUFFE-CARTER, LE VENTILATEUR OU LES DISPOSITIFS DE VARIATION DE PUISSANCE FACULTATIFS NE DOIVENT ETRE CONNECTES QU'A UN RESEAU DE MEME TENSION NOMINALE. LE TYPE ET LES CARACTERISTIQUES NOMINALES DU DISPOSITIF DE PROTECTION CONTRE LES SURINTENSITES DOIVENT ETRE CONFORMES AUX EXIGENCES DES POUVOIRS DE REGLEMENTATION VISANT LE PRODUIT FINI, VOIR LA PLAQUE SIGNALÉTIQUE.

NUR KUPFERVERBINDUNGEN VERWENDEN.

ZUR BESTIMMUNG DES BETRIEBSSTROMES MÜSSEN KABEL VERWENDET WERDEN, DIE FÜR EINE BELASTUNG VON MINDESTENS 75 °C GEEIGNET SIND.

ANLAGE NUR MIT ERDUNG VERWENDEN.

SCHUTZ BEI PHASENAUSFALL AUF DER PRIMARSEITE IST GEWAHRLEISTET.

SCHUTZGERÄT, KURBELGEHÄUSEHEIZER, ZUSATZLUFTER ODER LEISTUNGSREGELVENTIL(E) DÜRFEN NUR MIT NENNSPANUNG BETRIEBEN WERDEN. NENNLEISTUNG UND TYP DES ÜBERSTROMSCHUTZSCHALTERS MÜSSEN IN ÜBEREINSTIMMUNG MIT ZUTREFFENDEN VORSCHRIFTEN SEIN-BITTE TYPSCILD BEACHTEN.

**Discontinued**  
**Wiring Diagram 0841 (Right Side)**

### STAR DELTA CONNECTED

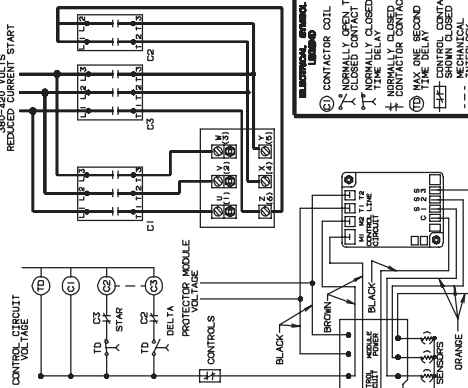

### DELTA CONNECTED

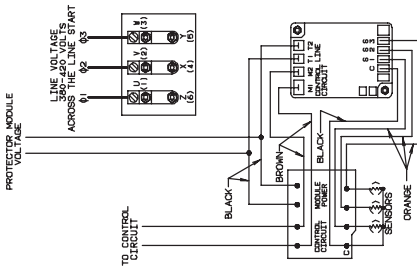

WHEN CHECKING SOLID STATE MODULE: USE OF SPIDER ORS (6 VOLTS MAXIMUM) TO TEST THE MODULE IS PERMITTED. DO NOT SHORT ACROSS THE TERMINALS.

RESISTANCE ACROSS EACH MOTOR SENSOR SHOULD BE APPROXIMATELY 500 TO 2400 OHMS WITH A MOTOR TEMPERATURE BELOW 60 °C.

MODULE HAS TWO MINUTE TIME DELAY BEFORE RESET IN EVENT OF PROTECTOR TRIP OR LOSS OF MODULE POWER.

USE COPPER CONDUCTORS ONLY.

USE MINIMUM 75 °C WIRE FOR AMPACITY DETERMINATION.

USE THIS EQUIPMENT ON A GROUNDED SYSTEM ONLY.

PRIMARY SINGLE PHASE FAILURE PROTECTION IS PROVIDED.

PROTECTOR MODULES WITH CAPACITY CONTROL VALVE(S) ONLY OR CAPACITY CONTROL VALVE(S) MUST BE CONNECTED TO THEIR RATED VOLTAGE.

OVERCURRENT PROTECTION, DEVICE RATING AND TYPE MUST BE IN ACCORDANCE WITH REGULATORY AGENCY END APPROVALS-SEE SYSTEM NAMEPLATE.

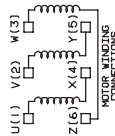

### PART WINDING START CONNECTED

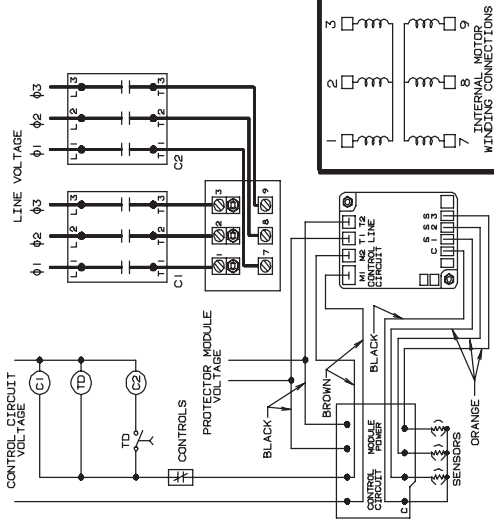

WHEN CHECKING SOLID STATE MODULE: USE OHMMETER ONLY (6 VOLTS MAXIMUM) TO CHECK TERMINALS RESISTANCE. DO NOT SHORT ACROSS THE RESISTANCE ACROSS EACH MOTOR SENSOR SHOULD BE APPROXIMATELY 600 TO 2400 OHMS WITH A MOTOR TEMPERATURE BELOW 60 C. A SHORTING OF THE LINE DELAY BEFORE RESET IN EVENT OF PROTECTOR TRIP OR LOSS OF MODULE POWER.

### ACROSS THE LINE CONNECTED

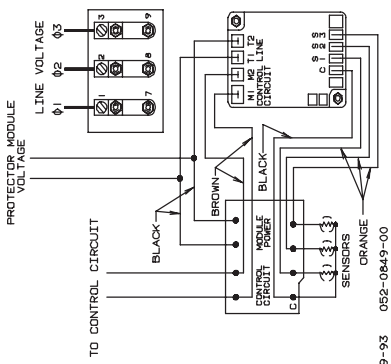

USE COPPER CONDUCTORS ONLY.  
USE MINIMUM 75 ° C WIRE FOR AMPACITY DETERMINATION.  
USE THIS EQUIPMENT ON A GROUNDED SYSTEM ONLY.  
PRIMARY SINGLE PHASE FAILURE PROTECTION IS PROVIDED.  
PROTECTOR MODULE AND OPTIONAL CRANKCASE HEATER FAN OR CAPACITY OVERCURRENT PROTECTION DEVICE RATING AND TYPE MUST BE IN ACCORDANCE WITH REGULATORY AGENCY END PRODUCT APPROVALS-SEE SYSTEM NAMEPLATE.

### ELECTRICAL SYMBOL LEGEND

- (C) CONTACTOR COIL
- (TD) MAX ONE SECOND TIME DELAY
- ⌘ NORMALLY OPEN TIME CLOSED CONTACT
- ⌘ NORMALLY OPEN CONTACTS
- ⌘ CONTROL CONTACTS SHOWN CLOSED

9-93 052-0849-00

Discontinued  
Wiring Diagram 0849

**WHEN CHECKING SOLID STATE MODULE:  
MODULE VOLTAGE MUST BE DISCONNECTED BEFORE  
CHECKING MOTOR SENSORS. TERMINAL "C" HAS THE  
SAME VOLTAGE AS TERMINAL "LI".**

USE OHMMETER ONLY TO CHECK SENSOR RESISTANCE.  
DO NOT SHORT ACROSS THE TERMINALS.

RESISTANCE ACROSS EACH MOTOR SENSOR SHOULD BE  
APPROXIMATELY 500 TO 2400 OHMS WITH A MOTOR  
TEMPERATURE BELOW 60 °C.

MODULE HAS TWO MINUTE TIME DELAY BEFORE RESET  
IN EVENT OF PROTECTOR TRIP OR LOSS OF MODULE  
POWER.

USE COPPER CONDUCTORS ONLY.

USE MINIMUM 75 °C WIRE FOR AMPACITY  
DETERMINATION.

USE THIS EQUIPMENT ON A GROUNDING SYSTEM ONLY.

PRIMARY SINGLE PHASE FAILURE PROTECTION  
IS PROVIDED.

PROTECTOR MODULE AND OPTIONAL CRANKCASE  
HEATER, FAN, OR CAPACITY CONTROL VALVE(S)  
MUST BE CONNECTED ONLY TO THEIR RATED  
VOLTAGE.

OVERCURRENT PROTECTION DEVICE RATING AND  
TYPE MUST BE IN ACCORDANCE WITH REGULATORY  
AGENCY END PRODUCT APPROVALS-SEE SYSTEM  
NAMEPLATE.

10-94 052-0853-00

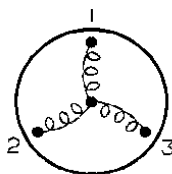

MOTOR WINDING CONNECTIONS

**Discontinued  
Wiring Diagram 0853 (Left Side)**

## ACROSS THE LINE CONNECTED

LINE VOLTAGE

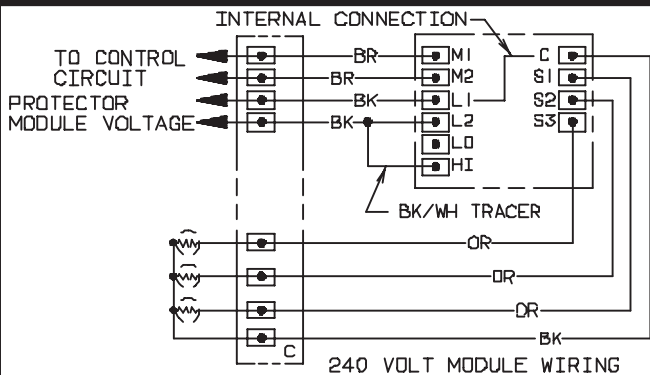
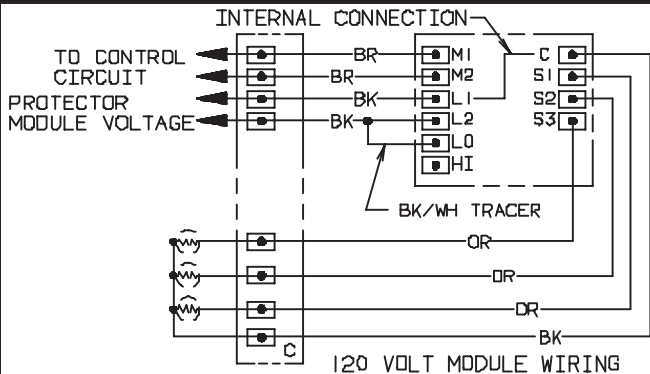
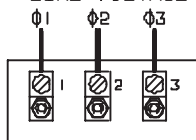

**Discontinued**  
**Wiring Diagram 0853 (Right Side)**

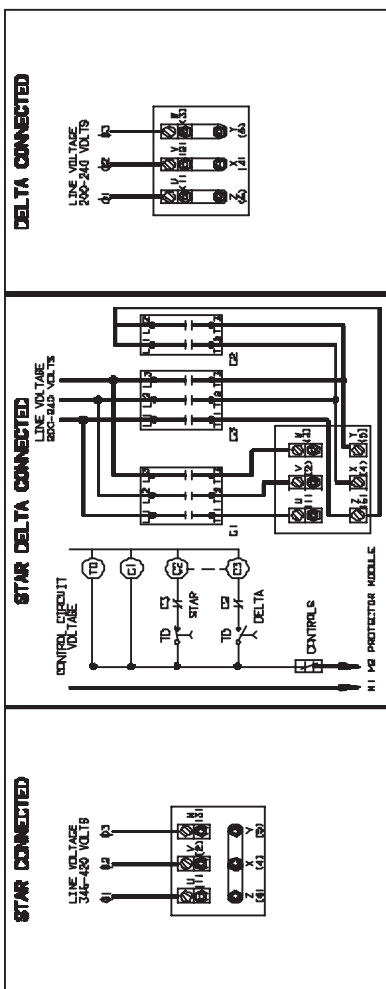

Discontinued  
Wiring Diagram 0854 (Top)



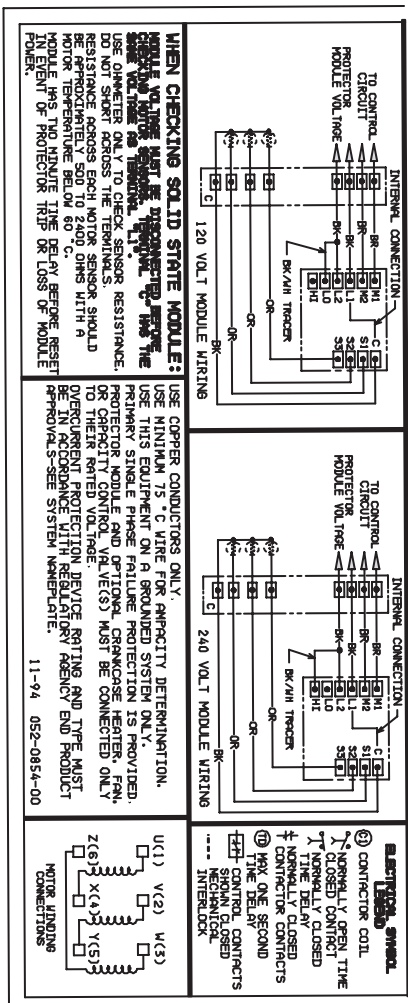

**Discontinued**  
**Wiring Diagram 0854 (Bottom)**

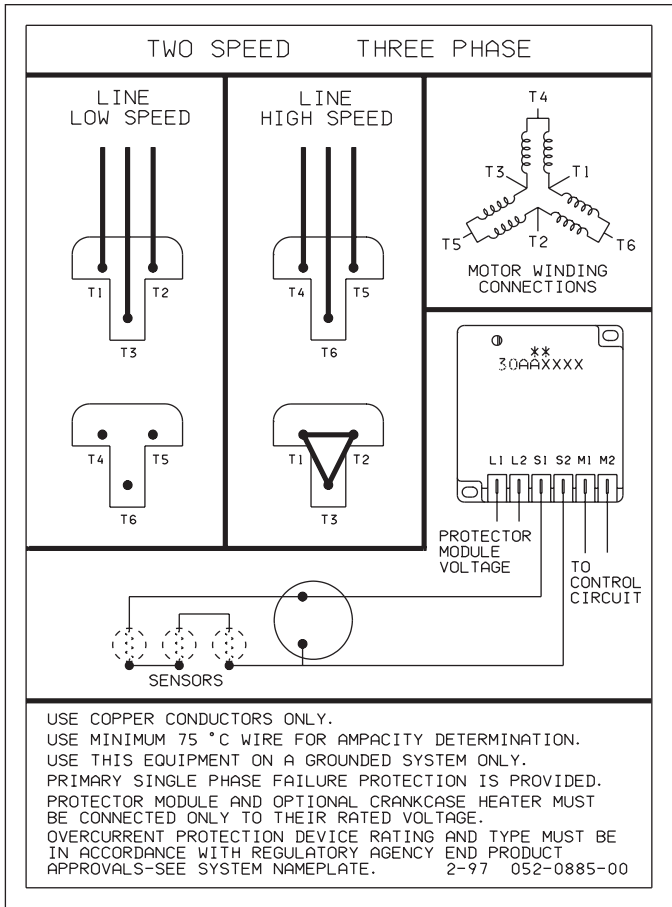

**Discontinued**  
**Wiring Diagram 0855**

**This page is left blank intentionally.**

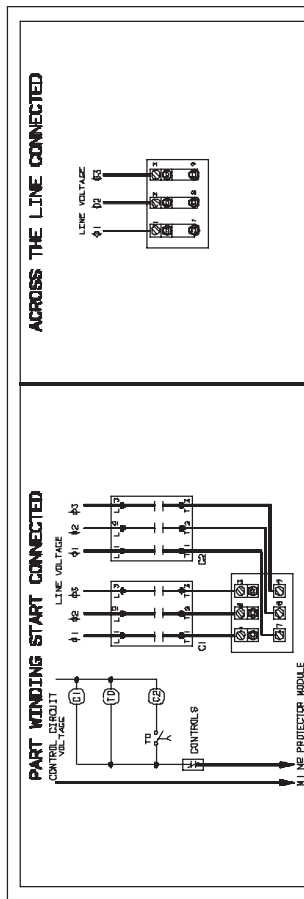

Discontinued  
 Wiring Diagram 0856 (Top)

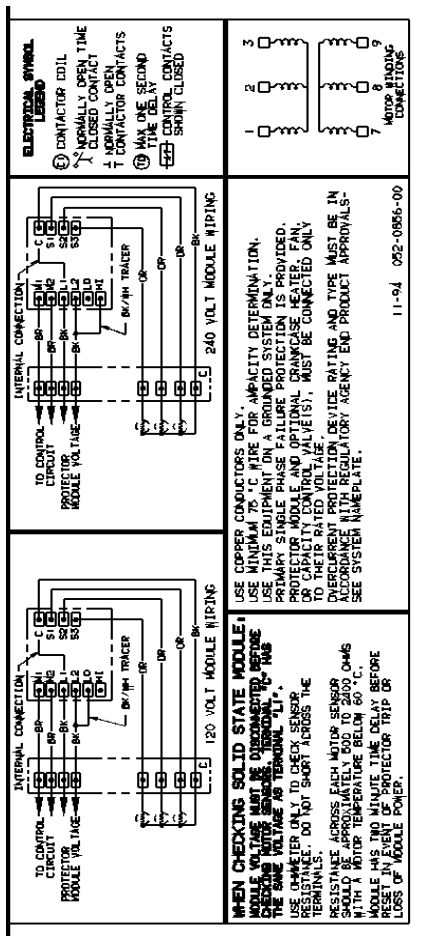

Discontinued  
Wiring Diagram 0856 (Bottom)

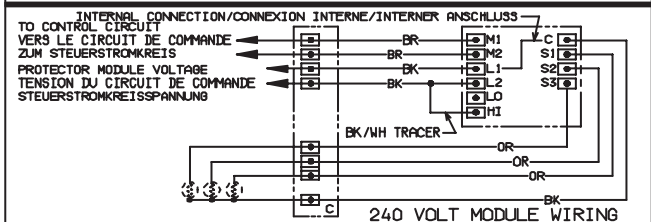
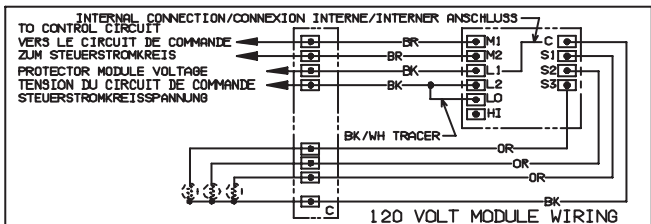

**WHEN CHECKING SOLID STATE MODULE:**  
**MODULE VOLTAGE MUST BE DISCONNECTED BEFORE CHECKING MOTOR SENSORS.**  
**TERMINAL "C" HAS THE SAME VOLTAGE AS TERMINAL "L1".**  
 USE OHMMETER ONLY TO CHECK SENSOR RESISTANCE.  
 DO NOT SHORT ACROSS THE TERMINALS.  
 RESISTANCE ACROSS EACH MOTOR SENSOR SHOULD BE APPROXIMATELY 500 TO 2400 OHMS WITH A MOTOR TEMPERATURE BELOW 60 °C.  
 MODULE HAS TWO MINUTE TIME DELAY BEFORE RESET IN EVENT OF PROTECTOR TRIP OR LOSS OF MODULE POWER.

**LORS DE LA VERTIFICATION DU MODULE ELECTRONIQUE.**  
**LE MODULE DOIT ETRE MIS hors TENSION AVANT DE VERIFIER LES CAPTEURS DU MOTEUR. LES BORNES "C" ET "L1" SONT A LA MEME TENSION.**  
 UTILISER SEULEMENT UN OHMMETRE POUR VERIFIER LA RESISTANCE DE LA SONDE. NE PAS COURT-CIRCUITER LES BORNES.  
 LA RESISTANCE ENTRE LES BORNES DE CHAQUE SONDE D'UN MOTEUR DEVRAIT ETRE APPROXIMATIVEMENT DE 500 A 2400 OHMS LORSQUE LA TEMPERATURE DU MOTEUR EST INFERIEURE A 60 °C.  
 LE MODULE MET DEUX MINUTES A SE REARMER S'IL MANQUE DE COURANT OU SI LE DISPOSITIF DE PROTECTION EST DECLENCHE.

**BEI PRUFUNG DES MOTORSCHUTZGERATES:**  
**VOR PRUFUNG DER MOTORSSENSOREN MUSS DIE SPANNUNGSVERSORGUNG ZUM MODUL UNTERBROCHEN WERDEN. ANSCHLUSS "C" HAT DIE GLEICHIGE SPANNUNG WIE ANSCHLUSS "L1".**  
 ZUM PRUFEN DER SENSORWIDERSTANDE NUR EIN OHMMETER VERWENDEN.  
 DIE SENSORANSCHLUSSE DUFREN NICHT UBERBRUCKT WERDEN.  
 DER SENSORWIDERSTAND SOLITE CIRCA 500 BIS 2400 OHM BETRAGEN BEI EINER MOTORTEMPORATUR UNTER 60 °C.  
 WENN GERAT ABGESCHALTET ODER DIE SPANNUNGSVERSORGUNG UNTERBROCHEN WAR, HAT DAS SCHUTZGERAT EINE ZEITVERZOGERUNG VON ZWEI MINUTEN ZUM RUCKSCHALTEN.

Discontinued  
 Wiring Diagram 0857 (Left Side)

### PART WINDING START CONNECTED

CONTROL CIRCUIT VOLTAGE  
TENSION DU CIRCUIT DE COMMANDE  
STEUERSTROMKREISSPANNUNG

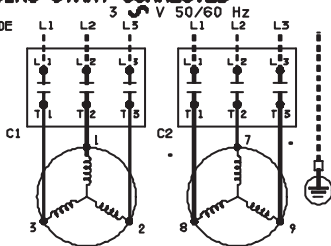
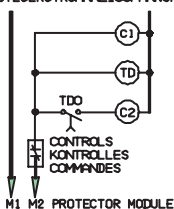

### ACROSS THE LINE CONNECTED

11-94 052-0857-00

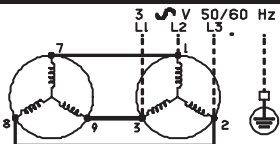

USE COPPER CONDUCTORS ONLY.

USE MINIMUM 75 °C WIRE FOR AMPACITY DETERMINATION

USE THIS EQUIPMENT ON A GROUNDED SYSTEM ONLY.

PRIMARY SINGLE PHASE FAILURE PROTECTION IS PROVIDED.

PROTECTOR MODULE AND OPTIONAL CRANKCASE HEATER, FAN, OR CAPACITY CONTROL VALVE(S), MUST BE CONNECTED ONLY TO THEIR RATED VOLTAGE.

OVERCURRENT PROTECTION DEVICE RATING AND TYPE MUST BE IN ACCORDANCE WITH REGULATORY AGENCY END PRODUCT APPROVALS-SEE SYSTEM NAMEPLATE.

N'UTILISER QUE DES CONDUCTEURS EN CUIVRE.

UTILISER UN FIL D'AU MOINS 75 °C POUR DETERMINER LE COURANT ADMISSIBLE.

UTILISER CE MATERIEL SEULEMENT DANS UN RESEAU MIS A LA TERRE.

PROTECTION PRIMAIRE MONOPHASEE FOURNIE.

LE MODULE DU DISPOSITIF DE PROTECTION ET LE CHAUFFE-CARTER, LE VENTILATEUR OU LES DISPOSITIFS DE VARIATION DE PUISSANCE FACULTATIFS NE DOIVENT ETRE CONNECTES QU'A UN RESEAU DE MEME TENSION NOMINALE.

LE TYPE ET LES CARACTERISTIQUES NOMINALES DU DISPOSITIF DE PROTECTION CONTRE LES SURINTENSITES DOIVENT ETRE CONFORMES AUX EXIGENCES DES POUVOIRS DE REGLEMENTATION VISANT LE PRODUIT FINI, VOIR LA PLAQUE SIGNALIETIQUE.

NUR KUPFERVERBINDUNGEN VERWENDEN.

ZUR BESTIMMUNG DES BETRIEBSSTROMES MUSSEN KABEL VERWENDET WERDEN. DIE FUEREINE BELASTUNG VON MINDESTENS 75 °C GEEIGNET SIND.

ANLAGE NUR MIT ERDUNG VERWENDEN.

SCHUTZ BEI PHASENAUSFALL AUF DER PRIMARSEITE IST GEWAHRLEISTET

SCHUTZGERAT, KURBELGEHAUSEHEIZER, ZUSATZLUFTER ODER LEISTUNGSREGELVENTIL(E) DURFEN NUR MIT NENNSPANNUNG BETRIEBEN WERDEN.

NENNLEISTUNG UND TYP DES UBERSTROMSCHUTZSCHALTERS MUSSEN IN UBEREINSTIMMUNG MIT ZUTREFFENDEN VORSCHRIFTEN SEIN-BITTE TYPSCILD BEACHTEN.

Discontinued  
Wiring Diagram 0857 (Right Side)

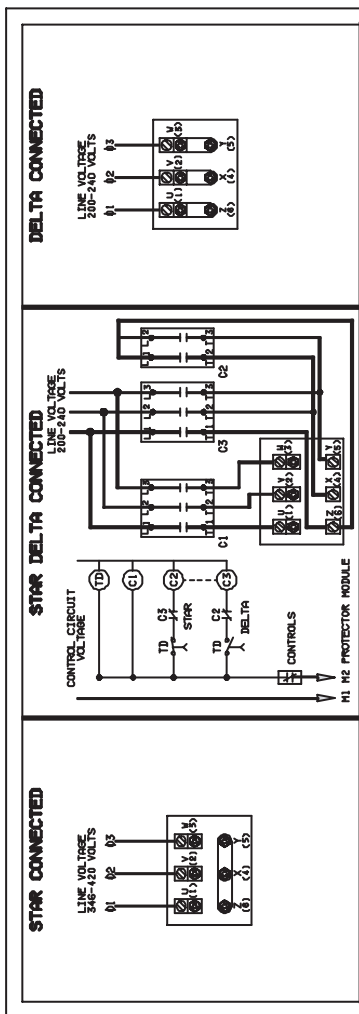

Discontinued  
Wiring Diagram 0858 (Top)



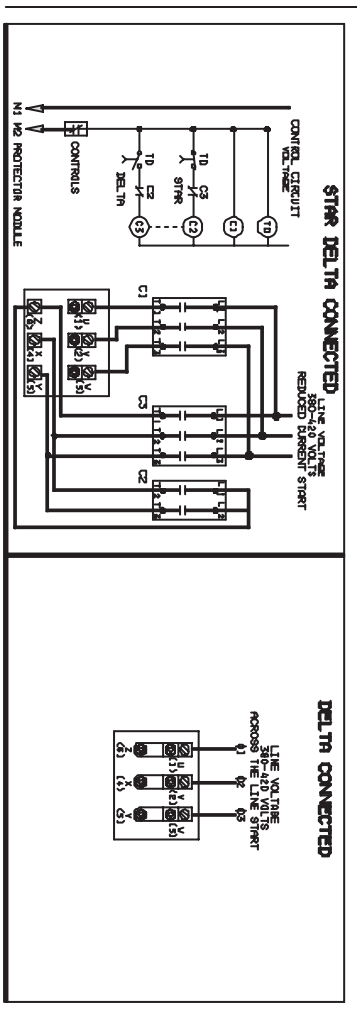

**Discontinued**  
**Wiring Diagram 0858 (Bottom)**

## PART WINDING START CONNECTED

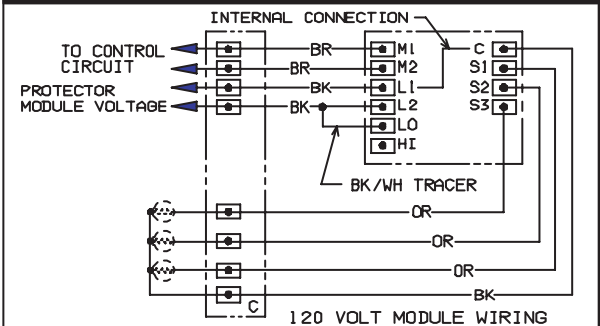
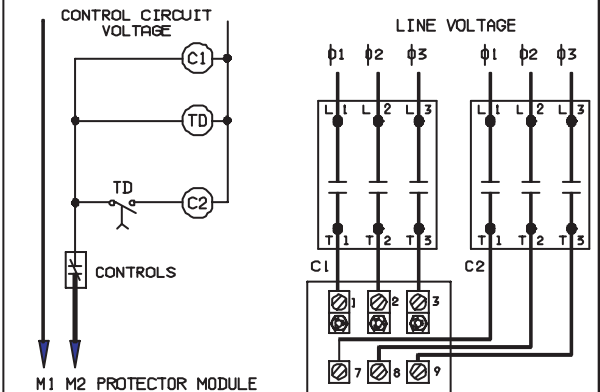

### WHEN CHECKING SOLID STATE MODULE:

**MODULE VOLTAGE MUST BE DISCONNECTED BEFORE CHECKING MOTOR SENSORS. TERMINAL "C" HAS THE SAME VOLTAGE AS TERMINAL "L1".**

USE OHMMETER ONLY TO CHECK SENSOR RESISTANCE. DO NOT SHORT ACROSS THE TERMINALS.

RESISTANCE ACROSS EACH MOTOR SENSOR SHOULD BE APPROXIMATELY 500 TO 2400 OHMS WITH A MOTOR TEMPERATURE BELOW 60 °C.

MODULE HAS TWO MINUTE TIME DELAY BEFORE RESET IN EVENT OF PROTECTOR TRIP OR LOSS OF MODULE POWER.

**Discontinued**  
**Wiring Diagram 0859 (Left Side)**

## ACROSS THE LINE CONNECTED

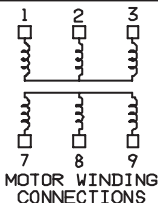
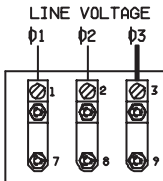

### ELECTRICAL SYMBOL LEGEND

- CONTACTOR COIL
- NORMALLY OPEN TIME CLOSED CONTACT
- NORMALLY OPEN CONTACTOR CONTACTS
- MAX ONE SECOND TIME DELAY
- CONTROL CONTACTS SHOWN CLOSED

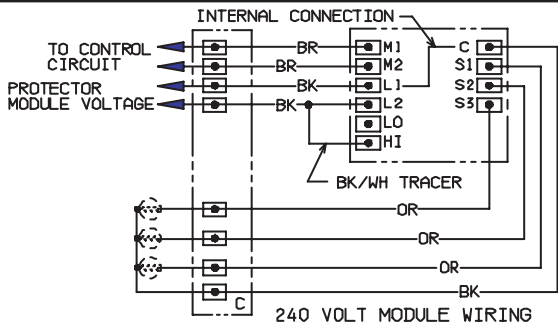

USE COPPER CONDUCTORS ONLY.  
 USE MINIMUM 75 °C WIRE FOR AMPACITY DETERMINATION.  
 USE THIS EQUIPMENT ON A GROUNDED SYSTEM ONLY.  
 PRIMARY SINGLE PHASE FAILURE PROTECTION IS PROVIDED.  
 PROTECTOR MODULE AND OPTIONAL CRANKCASE HEATER, FAN, OR  
 CAPACITY CONTROL VALVE(S), MUST BE CONNECTED ONLY TO  
 THEIR RATED VOLTAGE.  
 OVERCURRENT PROTECTION DEVICE RATING AND TYPE MUST BE  
 IN ACCORDANCE WITH REGULATORY AGENCY END PRODUCT  
 APPROVALS-SEE SYSTEM NAMEPLATE.      11-94 052-0859-00

**Discontinued**  
**Wiring Diagram 0859 (Right Side)**

USE COPPER CONDUCTORS ONLY. USE THIS EQUIPMENT ON A GROUNDING SYSTEM ONLY. USE MINIMUM 75C WIRE FOR AMPACITY DETERMINATION. INTERNAL MOTOR PROTECTION-ALLOW TIME FOR RESET. OVERCURRENT PROTECTION DEVICE RATING AND TYPE MUST BE IN ACCORDANCE WITH REGULATORY AGENCY END PRODUCT APPROVALS-SEE SYSTEM NAMEPLATE.

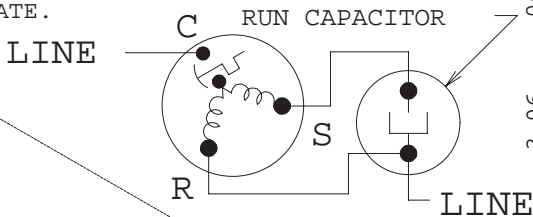

XX

005-0860-00

3-96

**Discontinued**  
**Wiring Diagram 005-0860**

USE COPPER CONDUCTORS ONLY. USE THIS EQUIPMENT ON A GROUNDED SYSTEM ONLY. USE MINIMUM 75 °C WIRE FOR AMPACITY DETERMINATION. INTERNAL MOTOR PROTECTION-ALLOW TIME FOR RESET. PRIMARY SINGLE PHASE FAILURE PROTECTION IS PROVIDED. CRANKCASE HEATER, WHEN APPLIED, MUST BE CONNECTED ONLY TO ITS RATED VOLTAGE. OVERCURRENT PROTECTION DEVICE RATING AND TYPE MUST BE IN ACCORDANCE WITH REGULATORY AGENCY END PRODUCT APPROVALS -SEE SYSTEM NAMEPLATE. TO CORRECT IMPROPER MOTOR ROTATION. SWITCH ANY TWO SUPPLY LINES. XX

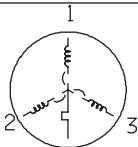

MOTOR  
WINDING CONNECTION

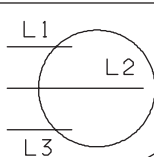

005-0868-00

7-96

**Discontinued**  
**Wiring Diagram 005-0868**

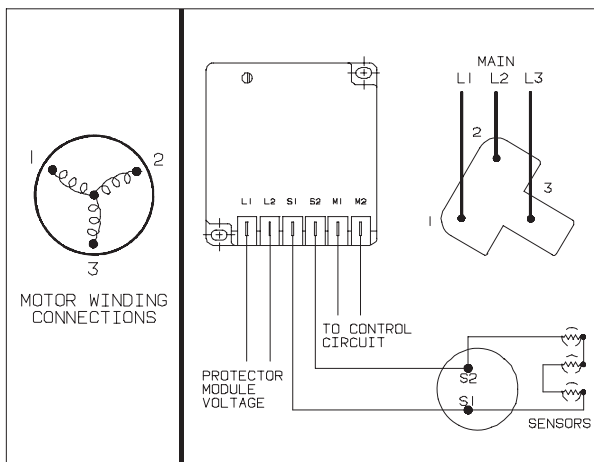

WHEN CHECKING SOLID STATE MODULE:

USE OHMMETER ONLY (6 VOLTS MAXIMUM) TO CHECK SENSOR RESISTANCE. DO NOT SHORT ACROSS THE TERMINALS.

RESISTANCE ACROSS MOTOR SENSORS SHOULD BE APPROXIMATELY 1500 TO 7800 OHMS WITH A MOTOR TEMPERATURE BELOW 60 °C.

USE COPPER CONDUCTORS ONLY.

USE MINIMUM 75 °C WIRE FOR AMPACITY DETERMINATION.

USE THIS EQUIPMENT ON A GROUNDED SYSTEM ONLY.

PRIMARY SINGLE PHASE FAILURE PROTECTION IS PROVIDED.

PROTECTOR MODULE AND OPTIONAL CRANKCASE HEATER MUST BE CONNECTED ONLY TO THEIR RATED VOLTAGE.

OVERCURRENT PROTECTION DEVICE RATING AND TYPE MUST BE IN ACCORDANCE WITH REGULATORY AGENCY END PRODUCT APPROVALS-SEE SYSTEM NAMEPLATE.

4-96

052-0874-00

**Discontinued**  
**Wiring Diagram 0874**

### DELTA CONNECTED

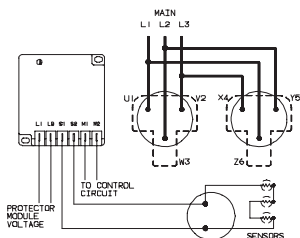

### STAR CONNECTED

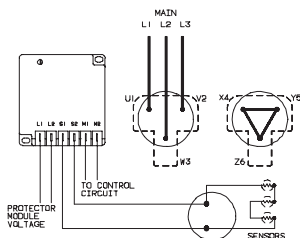

#### WHEN CHECKING PROTECTOR

USE OHMMETER ONLY (6 VOLTS MAXIMUM) TO CHECK SENSOR RESISTANCE. DO NOT SHORT ACROSS THE TERMINALS.

RESISTANCE ACROSS MOTOR SENSORS SHOULD BE APPROXIMATELY 750 OHMS WITH A MOTOR TEMPERATURE BELOW 60 °C.

USE COPPER CONDUCTORS ONLY.  
USE MINIMUM 75 °C WIRE FOR AMPACITY DETERMINATION.

USE THIS EQUIPMENT ON A GROUNDED SYSTEM ONLY.

PRIMARY SINGLE PHASE FAILURE PROTECTION IS PROVIDED.

PROTECTOR MODULE AND OPTIONAL CRANKCASE HEATER MUST BE CONNECTED ONLY TO THEIR RATED VOLTAGE.

OVERCURRENT PROTECTION DEVICE RATING AND TYPE MUST BE IN ACCORDANCE WITH REGULATORY AGENCY END PRODUCT APPROVALS-SEE SYSTEM NAMEPLATE.



MOTOR WINDING CONNECTIONS

10-95 052-0875-00

**Discontinued**  
**Wiring Diagram 0875**

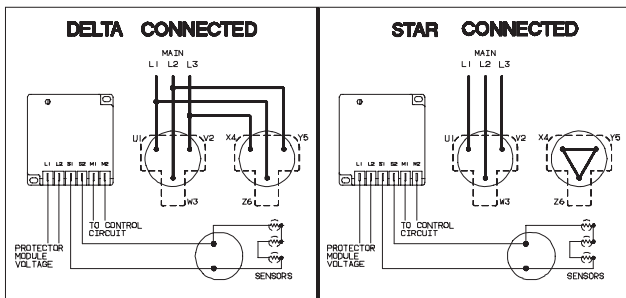

WHEN CHECKING PROTECTOR  
USE OHMMETER ONLY (6 VOLTS MAXIMUM)  
TO CHECK SENSOR RESISTANCE. DO NOT  
SHORT ACROSS THE TERMINALS.

RESISTANCE ACROSS MOTOR SENSORS SHOULD  
BE APPROXIMATELY 750 OHMS WITH A MOTOR  
TEMPERATURE BELOW 60 °C.

MODULE HAS FOUR MINUTE TIME DELAY  
BEFORE RESET IN EVENT OF PROTECTOR  
TRIP OR LOSS OF MODULE POWER.

USE COPPER CONDUCTORS ONLY.  
USE MINIMUM 75 °C WIRE FOR  
AMPACITY DETERMINATION.

USE THIS EQUIPMENT ON A GROUND  
SYSTEM ONLY.

PRIMARY SINGLE PHASE FAILURE  
PROTECTION IS PROVIDED.

PROTECTOR MODULE AND OPTIONAL  
CRANKCASE HEATER MUST BE CONNECTED  
ONLY TO THEIR RATED VOLTAGE.

OVERCURRENT PROTECTION DEVICE  
RATING AND TYPE MUST BE IN  
ACCORDANCE WITH REGULATORY  
AGENCY END PRODUCT APPROVALS-  
SEE SYSTEM NAMEPLATE.



MOTOR WINDING  
CONNECTIONS

10-95 052-0876-00

**Discontinued**  
**Wiring Diagram 0876**



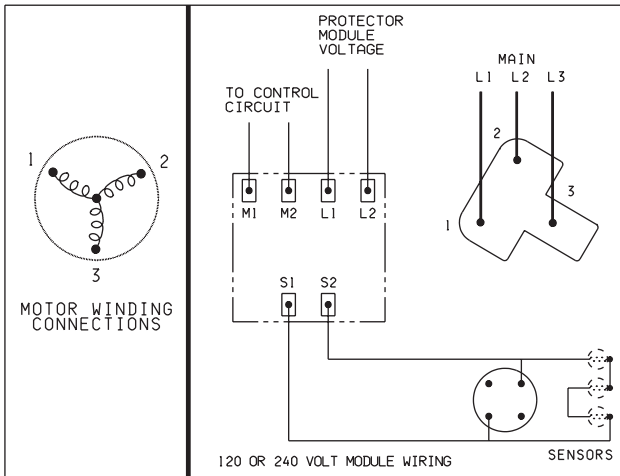

### WHEN CHECKING PROTECTOR

USE OHMMETER ONLY (6 VOLTS MAXIMUM) TO CHECK SENSOR RESISTANCE. DO NOT SHORT ACROSS THE TERMINALS.

SENSOR RESISTANCE MEASURED FROM TERMINALS S1 TO S2 WITH MOTOR TEMPERATURE BELOW 60 °C (140° F), SHOULD BE WITHIN THE FOLLOWING LIMIT: 90 TO 7800 OHMS.

IN EVENT OF PROTECTOR TRIP OR LOSS OF MODULE POWER, MODULES MAY HAVE NO MINIMUM OFF TIME OR FOUR MINUTE MINIMUM OFF TIME.

USE COPPER CONDUCTORS ONLY.

USE MINIMUM 75 °C WIRE FOR AMPACITY DETERMINATION.

USE THIS EQUIPMENT ON A GROUNDED SYSTEM ONLY.

PRIMARY SINGLE PHASE FAILURE PROTECTION IS PROVIDED.

PROTECTOR MODULE AND OPTIONAL CRANKCASE HEATER MUST BE CONNECTED ONLY TO THEIR RATED VOLTAGE.

OVERCURRENT PROTECTION DEVICE RATING AND TYPE MUST BE IN ACCORDANCE WITH REGULATORY AGENCY END PRODUCT APPROVALS-SEE SYSTEM NAMEPLATE.

1-04

052-0882-00

**Discontinued**  
**Wiring Diagram 0882**

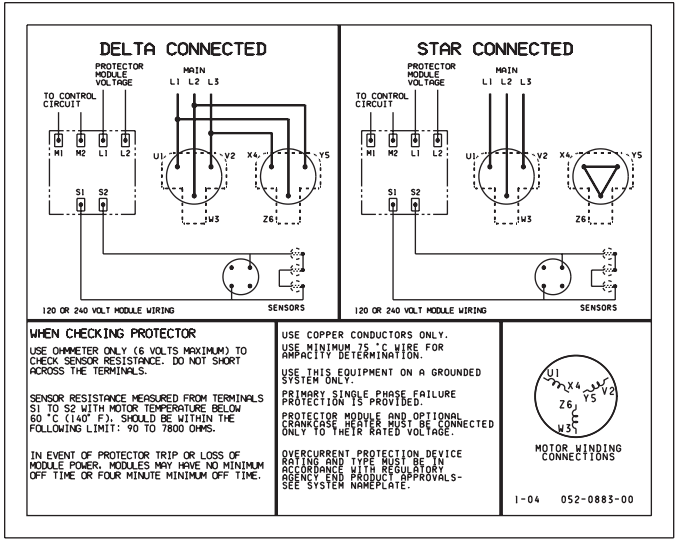

**Discontinued**  
**Wiring Diagram 0883**

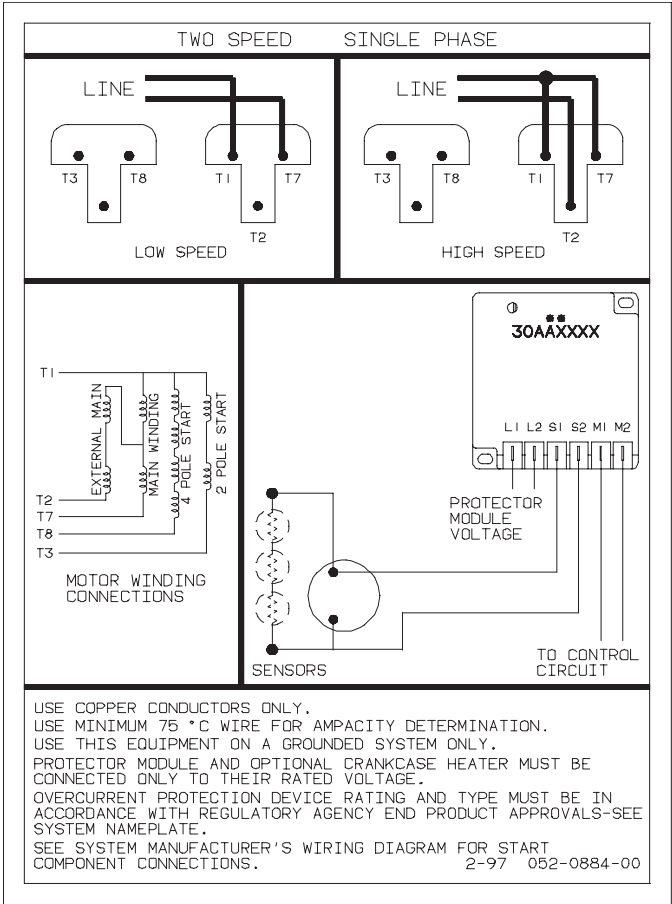

**Discontinued**  
**Wiring Diagram 0884**

TWO SPEED THREE PHASE

LINE  
LOW SPEED

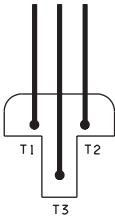

LINE  
HIGH SPEED

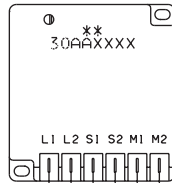
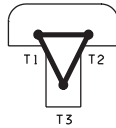
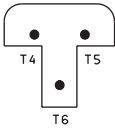
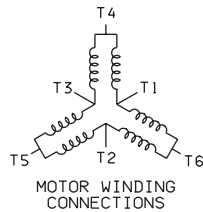
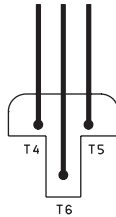

PROTECTOR  
MODULE  
VOLTAGE

TO CONTROL  
CIRCUIT

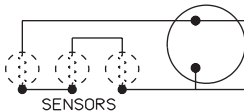

USE COPPER CONDUCTORS ONLY.  
 USE MINIMUM 75 °C WIRE FOR AMPACITY DETERMINATION.  
 USE THIS EQUIPMENT ON A GROUNDED SYSTEM ONLY.  
 PRIMARY SINGLE PHASE FAILURE PROTECTION IS PROVIDED.  
 PROTECTOR MODULE AND OPTIONAL CRANKCASE HEATER MUST  
 BE CONNECTED ONLY TO THEIR RATED VOLTAGE.  
 OVERCURRENT PROTECTION DEVICE RATING AND TYPE MUST BE  
 IN ACCORDANCE WITH REGULATORY AGENCY END PRODUCT  
 APPROVALS-SEE SYSTEM NAMEPLATE. 2-97 052-0885-00

**Discontinued**  
**Wiring Diagram 0885**

**This page is left blank intentionally.**

### WHEN CHECKING MOTOR PROTECTION SYSTEM:

MODULE VOLTAGE MUST BE DISCONNECTED BEFORE CHECKING MOTOR SENSORS.

USE OHMMETER ONLY TO CHECK SENSOR RESISTANCE.  
DO NOT SHORT ACROSS THE TERMINALS.

SENSOR RESISTANCE MEASURED FROM TERMINALS  
(C TO S1,S2,S3) WITH MOTOR TEMPERATURE BELOW  
60 °C (140 °F), SHOULD BE WITHIN THE FOLLOWING  
LIMIT: 30 TO 2400 OHMS.

REFER TO COPELAND AE BULLETIN #10-1264.

MODULE HAS TWO MINUTE TIME DELAY BEFORE RESET IN  
EVENT OF PROTECTOR TRIP OR LOSS OF MODULE POWER.

### USE COPPER CONDUCTORS ONLY.

USE MINIMUM 75 °C (167 °F) WIRE FOR AMPACITY  
DETERMINATION.

USE THIS EQUIPMENT ON A GROUNDED SYSTEM ONLY.

PRIMARY SINGLE PHASE FAILURE PROTECTION  
IS PROVIDED.

PROTECTOR MODULE AND OPTIONAL CRANKCASE  
HEATER, FAN, OR CAPACITY CONTROL VALVE(S)  
MUST BE CONNECTED ONLY TO THEIR RATED  
VOLTAGE.

OVERCURRENT PROTECTION DEVICE RATING AND  
TYPE MUST BE IN ACCORDANCE WITH REGULATORY  
AGENCY END PRODUCT APPROVALS-SEE SYSTEM  
NAMEPLATE.

8-03 052-0896-00

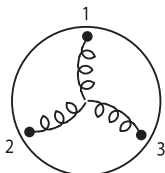

MOTOR WINDING CONNECTIONS

**Discontinued**  
**Wiring Diagram 0896 (Left Side)**

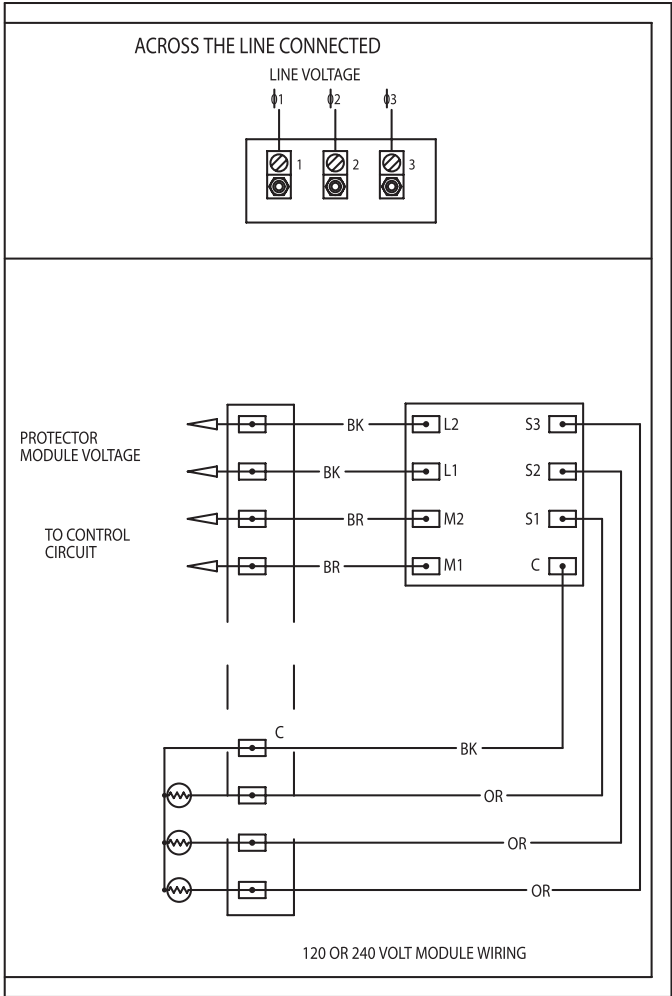

**Discontinued**  
**Wiring Diagram 0896 (Right Side)**

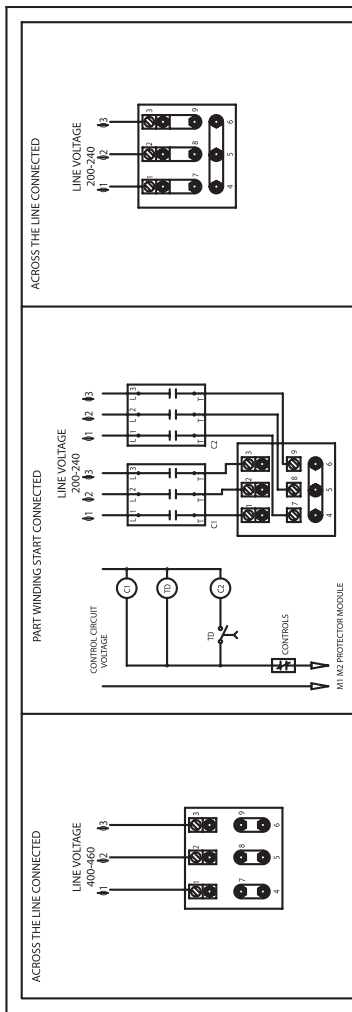

**Discontinued**  
**Wiring Diagram 0898 (Top)**



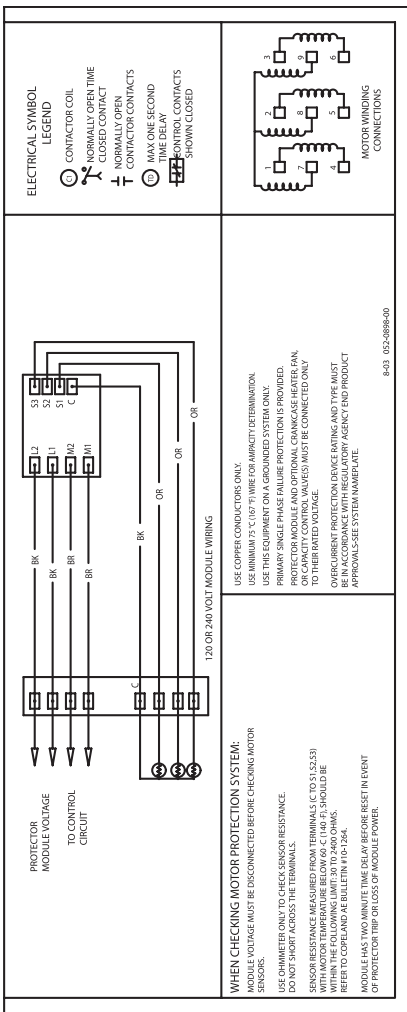

**Discontinued**  
**Wiring Diagram 0898 (Bottom)**

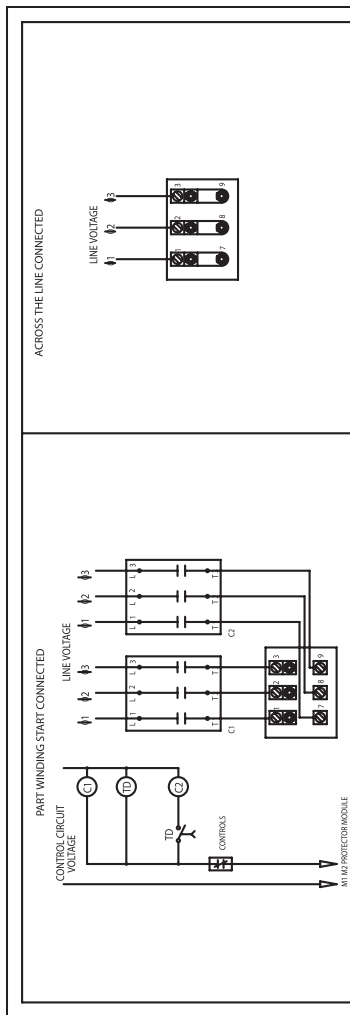

**Discontinued**  
**Wiring Diagram 0899 (Top)**

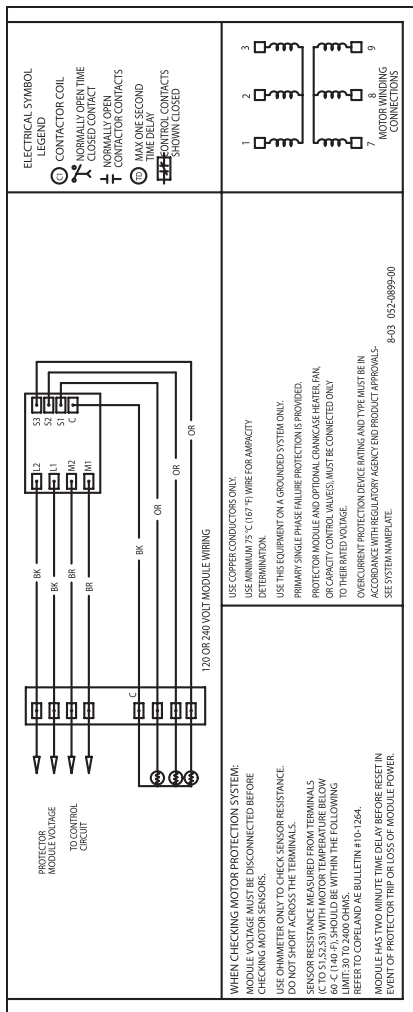

**Discontinued**  
**Wiring Diagram 0899 (Bottom)**

PROTECTOR MODULE VOLTAGE  
TENSION DU CIRCUIT DE COMMANDE  
STEUERSTROMKREISSPANNUNG

TO CONTROL CIRCUIT  
VERS LE CIRCUIT DE COMMANDE  
ZUM STEUERSTROMKREIS

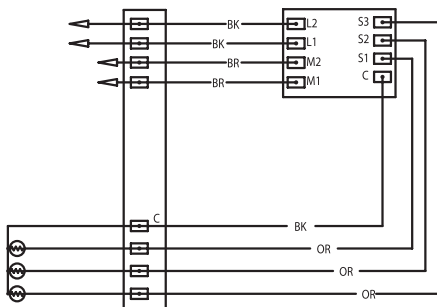

120 OR 240 VOLT MODULE WIRING

**WHEN CHECKING MOTOR PROTECTION SYSTEM:**

MODULE VOLTAGE MUST BE DISCONNECTED BEFORE CHECKING MOTOR SENSORS.  
USE OHMMETER ONLY TO CHECK SENSOR RESISTANCE.  
DO NOT SHORT ACROSS THE TERMINALS.

SENSOR RESISTANCE MEASURED FROM TERMINALS (C TO S1,S2,S3) WITH MOTOR TEMPERATURE BELOW 60 °C (140 °F), SHOULD BE WITHIN THE FOLLOWING LIMIT: 30 TO 2400 OHMS.  
REFER TO COPELAND AE BULLETIN #10-1264.

MODULE HAS TWO MINUTE TIME DELAY BEFORE RESET IN EVENT OF PROTECTOR TRIP OR LOSS OF MODULE POWER.

**INSTRUCTIONS POUR CONTROLER LE SYSTEME DE PROTECTION**

**DU MOTEUR:**

L'ALIMENTATION DU MODULE DOIT ETRE DISCONNECTEE AVANT DE CONTROLER LES CAPTEURS DU MOTEUR.

UTILISEZ SEULEMENT UN OHMMETER POUR CONTROLER LA RESISTANCE DU CAPTEUR.  
NE COURT-CIRCUITEZ PAS LES TERMINAISONS DES CAPTEURS.

LA VALEUR DE RESISTANCE D'UN CAPTEUR ENTRE TERMINAISONS (ENTRE C ET S1,S2,S3) LORSQUE LA TEMPERATURE DU MOTEUR EST INFIEURIE A 60 °C (140 °F), DOIT ETRE COMPRISE ENTRE 30 ET 2400 OHMS.

CONSULTEZ LE BULLETIN D'APPLICATION NUMERO 10-1264 DES PRODUITS COPELAND.

LE MODULE A UN DELAI DE RE-INITIALISATION DE DEUX MINUTES APRES DECLANCHEMENT DE LA PROTECTION, OU APRES UNE COUPEURE D'ALIMENTATION DU MODULE.

**BEIM UEBERPRUEFEN DES MOTORSCHUTZES:**

VOR UEBERPRUEFUNG DES MOTORSCHUTZES, MODULSTROMZUFUEHRUNG ABSCHALTEN.

SCHUTZWIDERSTAND NUR MIT OHMMETER MESSEN.  
ANSCHLUESSE NICHT KURZSCHLIESSEN.

GRENZWERTE DER SCHUTZWIDERSTANDE GEMESSEN AN DEN ANSCHLUESSEN (C ZU S1,S2,S3) BEI MOTORTEMPERATUR UNTER 60 °C (140 °F): 30 BIS 2400 OHM.

SIEHE COPELAND TECHNISCHE MITTEILUNG NR. 10-1264.

MODUL HAT ZWEI MINUTEN VERZOEGERUNG VOR RUECKSCHALTUNG IM FALLE EINER SCHUTZAUSLOESUNG ODER EINES MODULSTROMAUSFALLS.

**Discontinued  
Wiring Diagram 0902 (Left Side)**

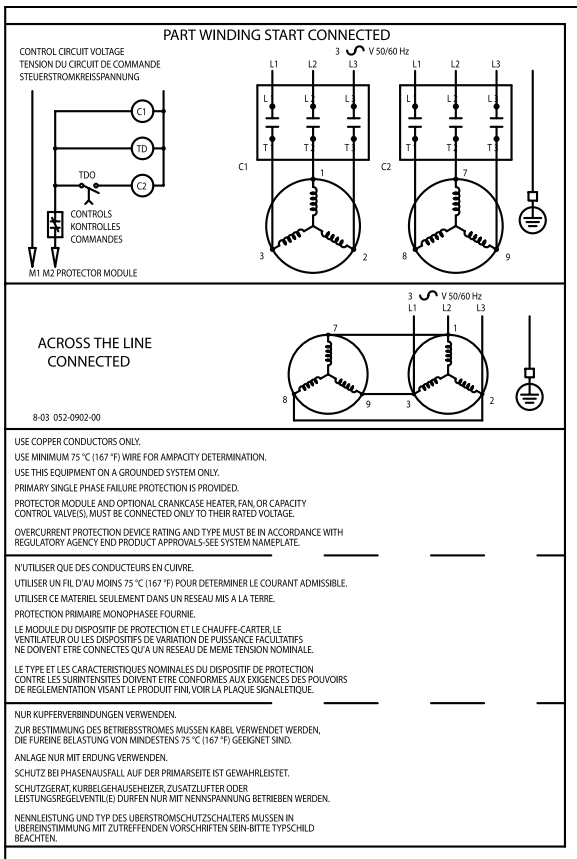

**Discontinued**  
**Wiring Diagram 0902 (Right Side)**

### DELTA CONNECTED

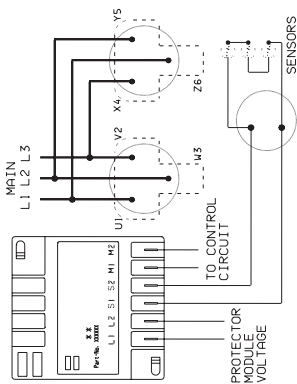

#### WHEN CHECKING PROTECTOR

USE OHMMETER ONLY (6 VOLTS MAXIMUM) TO CHECK SENSOR RESISTANCE. DO NOT SHORT ACROSS THE TERMINALS.

SENSOR RESISTANCE MEASURED FROM TERMINALS S1 TO S2 WITH MOTOR TEMPERATURE BELOW 60° C (140° F) SHOULD BE WITHIN THE FOLLOWING LIMIT 1500 TO 7800 OHMS.

IN EVENT OF PROTECTOR TRIP OR LOSS OF MODULE POWER, MODULES MAY HAVE NO MINIMUM OFF TIME OR FOUR MINUTE MINIMUM OFF TIME.

### STAR CONNECTED

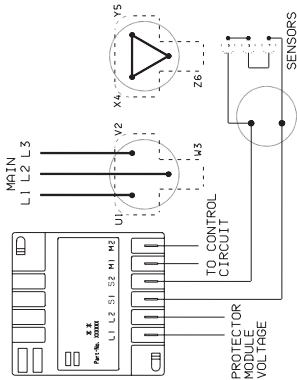

#### USE COPPER CONDUCTORS ONLY.

USE MINIMUM 75 °C WIRE FOR AMPACITY DETERMINATION.

USE THIS EQUIPMENT ON A GROUNDED SYSTEM ONLY.

PRIMARY SINGLE PHASE FAILURE PROTECTION IS PROVIDED.

PROTECTOR MODULE AND OPTIONAL CRANKCASE HEATER MUST BE CONNECTED ONLY TO THEIR RATED VOLTAGE.

OVERCURRENT PROTECTION DEVICE RATING AND TYPE MUST BE IN ACCORDANCE WITH REGULATORY AGENCY END PRODUCT APPROVALS—SEE SYSTEM NAMEPLATE.



MOTOR WINDING CONNECTIONS

1-04 052-0917-00

## Discontinued Wiring Diagram 0917

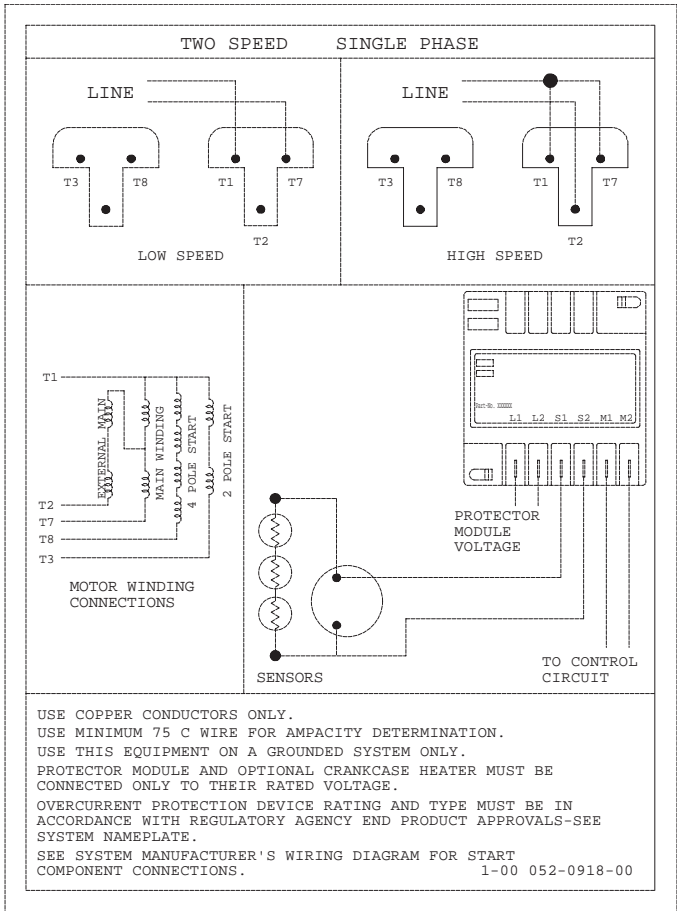

**Discontinued**  
**Wiring Diagram 0918**

## TWO SPEED THREE PHASE

LINE  
LOW SPEED

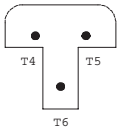
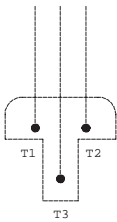

LINE  
HIGH SPEED

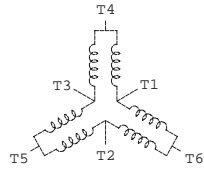
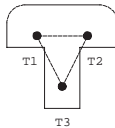
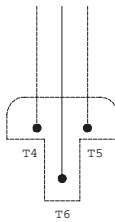

MOTOR WINDING  
CONNECTIONS

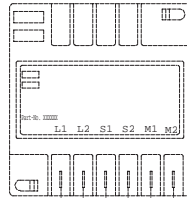

PROTECTOR  
MODULE  
VOLTAGE

TO  
CONTROL  
CIRCUIT

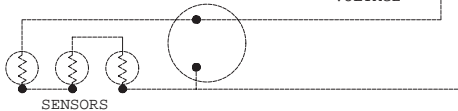

USE COPPER CONDUCTORS ONLY.  
 USE MINIMUM 75 C WIRE FOR AMPACITY DETERMINATION.  
 USE THIS EQUIPMENT ON A GROUNDED SYSTEM ONLY.  
 PRIMARY SINGLE PHASE FAILURE PROTECTION IS PROVIDED.  
 PROTECTOR MODULE AND OPTIONAL CRANKCASE HEATER MUST  
 BE CONNECTED ONLY TO THEIR RATED VOLTAGE.  
 OVERCURRENT PROTECTION DEVICE RATING AND TYPE MUST BE  
 IN ACCORDANCE WITH REGULATORY AGENCY END PRODUCT  
 APPROVALS-SEE SYSTEM NAMEPLATE. 1-00 052-0919-00

**Discontinued**  
**Wiring Diagram 0919**



USE COPPER CONDUCTORS ONLY. USE THIS EQUIPMENT ON A GROUNDED SYSTEM ONLY. USE MINIMUM 75°C WIRE FOR AMPACITY DETERMINATION. INTERNAL MOTOR PROTECTION-ALLOW TIME FOR RESET. PRIMARY SINGLE PHASE FAILURE PROTECTION IS PROVIDED. CRANKCASE HEATER, WHEN APPLIED, MUST BE CONNECTED ONLY TO ITS RATED VOLTAGE. OVERCURRENT PROTECTION DEVICE RATING AND TYPE MUST BE IN ACCORDANCE WITH REGULATORY AGENCY END PRODUCT APPROVALS -SEE SYSTEM NAMEPLATE. TO CORRECT IMPROPER MOTOR ROTATION. SWITCH ANY TWO SUPPLY LINES. XX

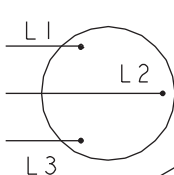
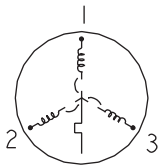

005-0922-00  
3-98

MOTOR WINDING CONNECTION

**Discontinued**  
**Wiring Diagram 005-0922**

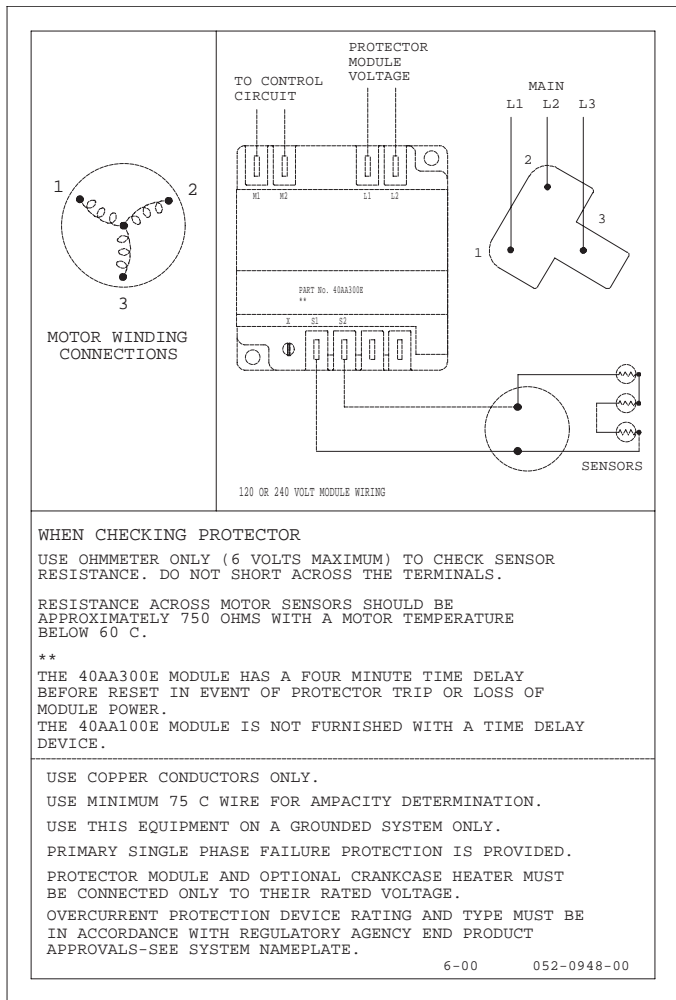

**Discontinued**  
**Wiring Diagram 0948**

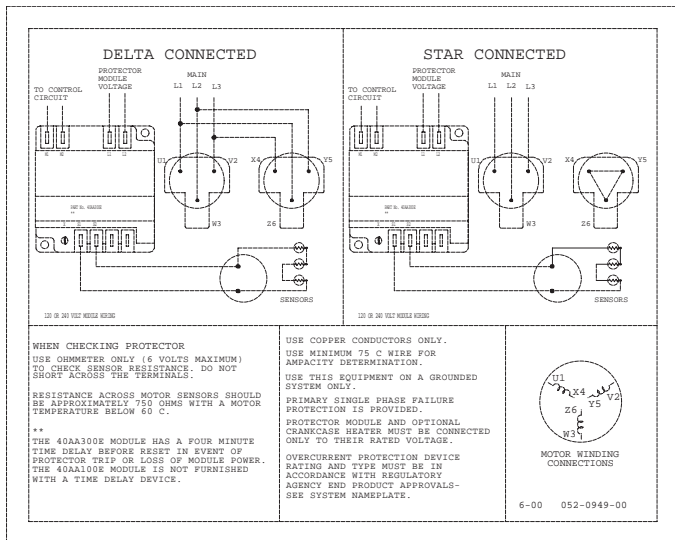

**Discontinued**  
**Wiring Diagram 0949**

USE COPPER CONDUCTORS ONLY. USE THIS EQUIPMENT ON A GROUNDED SYSTEM ONLY. USE MINIMUM 75 °C WIRE FOR AMPACITY DETERMINATION. INTERNAL MOTOR PROTECTION-ALLOW TIME FOR RESET. PRIMARY SINGLE PHASE FAILURE PROTECTION IS PROVIDED. CRANKCASE HEATER, WHEN APPLIED, MUST BE CONNECTED ONLY TO ITS RATED VOLTAGE. OVERCURRENT PROTECTION DEVICE RATING AND TYPE MUST BE IN ACCORDANCE WITH REGULATORY AGENCY END PRODUCT APPROVALS - SEE SYSTEM NAMEPLATE. TO CORRECT IMPROPER MOTOR ROTATION, SWITCH ANY TWO SUPPLY LINES

XX

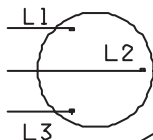
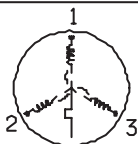

005-1043-00

10-01

MOTOR  
WINDING CONNECTION

**Discontinued**  
**Wiring Diagram 005-1043**

USE COPPER CONDUCTORS ONLY. USE MINIMUM  
75°C WIRE FOR AMPACITY DETERMINATION.  
INTERNAL MOTOR PROTECTION-ALLOW TIME  
FOR RESET. OVERCURRENT PROTECTION  
DEVICE RATING AND TYPE MUST BE IN  
ACCORDANCE WITH REGULATORY AGENCY END  
PRODUCT APPROVALS-SEE SYSTEM NAMEPLATE.  
CRANKCASE HEATER, WHEN APPLIED,  
MUST BE CONNECTED ONLY TO ITS RATED  
VOLTAGE. TO CORRECT IMPROPER ROTATION  
OF THREE PHASE MODELS, SWITCH ANY  
TWO SUPPLY LINES. REFER TO THE  
APPLICABLE SYSTEM WIRING DIAGRAM.

XX

005-1062-00

7-02

**Discontinued**  
**Wiring Diagram 005-1062**

USE COPPER CONDUCTORS ONLY. USE MINIMUM  
75° C WIRE FOR AMPACITY DETERMINATION.  
INTERNAL MOTOR PROTECTION - ALLOW TIME  
FOR RESET OVERCURRENT PROTECTION  
DEVICE RATING AND TYPE MUST BE IN  
ACCORDANCE WITH REGULATORY AGENCY END  
PRODUCT APPROVALS-SEE SYSTEM NAMEPLATE  
CRANKCASE HEATER, WHEN APPLIED,  
MUST BE CONNECTED ONLY TO ITS RATED  
VOLTAGE. TO CORRECT IMPROPER ROTATION  
OF THREE PHASE MODELS, SWITCH ANY  
TWO SUPPLY LINES. REFER TO THE  
APPLICABLE SYSTEM WIRING DIAGRAM.

XX

005-1071-00

2-03

**Discontinued**  
**Wiring Diagram 005-1071**

USE COPPER CONDUCTORS ONLY. USE THIS EQUIPMENT ON A GROUNDED SYSTEM ONLY. USE MINIMUM 75 °C WIRE FOR AMPACITY DETERMINATION. INTERNAL MOTOR PROTECTION-ALLOW TIME FOR RESET. PRIMARY SINGLE PHASE FAILURE PROTECTION IS PROVIDED.

CRANKCASE HEATER, WHEN APPLIED, MUST BE CONNECTED ONLY TO ITS RATED VOLTAGE. OVERCURRENT PROTECTION DEVICE RATING AND TYPE MUST BE IN ACCORDANCE WITH REGULATORY END PRODUCT APPROVALS-SEE SYSTEM NAMEPLATE. EXTERNAL THERMOSTAT, WHEN PROVIDED, MUST BE FIELD CONNECTED TO 24 VOLT COMPRESSOR CONTROL CIRCUIT. TO CORRECT IMPROPER MOTOR ROTATION, SWITCH ANY TO SUPPLY LINES.

052-1196-00

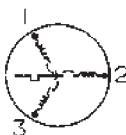

MOTOR

WINDING CONNECTION

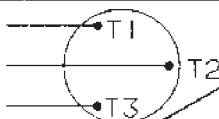

A-95

**Discontinued**  
**Wiring Diagram 1196**

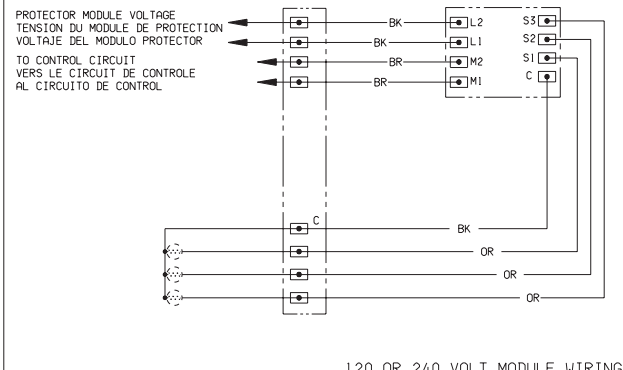

120 OR 240 VOLT MODULE WIRING

**WHEN CHECKING MOTOR PROTECTION SYSTEM:**

MODULE VOLTAGE MUST BE DISCONNECTED BEFORE CHECKING MOTOR SENSORS.  
 USE OHMMETER ONLY TO CHECK SENSOR RESISTANCE.  
 DO NOT SHORT ACROSS THE TERMINALS.  
 SENSOR RESISTANCE MEASURED FROM TERMINALS (C TO S1,S2,S3) WITH MOTOR TEMPERATURE BELOW 60 °C (140 °F), SHOULD BE WITHIN THE FOLLOWING LIMIT: 30 TO 2400 OHMS.  
 REFER TO COPELAND AE BULLETIN #10-1264.  
 MODULE HAS TWO MINUTE TIME DELAY BEFORE RESET IN EVENT OF PROTECTOR TRIP OR LOSS OF MODULE POWER.

**POUR VÉRIFIER LE SYSTÈME DE PROTECTION DU MOTEUR:**

LA TENSION DU MODULE DOIT ÊTRE DECONNECTÉE AVANT DE VÉRIFIER LES CAPTEURS DU MOTEUR.  
 UTILISER UNIQUEMENT UN OHMMÈTRE POUR VÉRIFIER LA RÉSISTANCE DE CAPTEUR.  
 NE PAS CAUSER DE COURT-CIRCUIT ENTRE LES BORNES.  
 LA RÉSISTANCE DE CAPTEUR MESURÉE ENTRE LES BORNES (C À S1,S2,S3) AVEC LA TEMPÉRATURE DU MOTEUR INFÉRIEURE À 60 °C (140 °F), DOIT ÊTRE DANS LA PLAGE SUIVANTE: 30 À 2400 OHMS.  
 SE REPORTER AU BULLETIN COPELAND AE N° 10-1264.  
 LE MODULE A UN TEMPS D'ATTENTE DE DEUX MINUTES AVANT DE SE REINITIALISER EN CAS DE DÉCLENCHEMENT DE LA PROTECTION OU DE COUPURE DE L'ALIMENTATION DU MODULE.

**AL VERIFICAR EL SISTEMA DE PROTECCIÓN DEL MOTOR:**

DEBE DESCONECTAR EL VOLTAJE DEL MODULO ANTES DE VERIFICAR LOS SENSORES DEL MOTOR.  
 UTILICE EL OHMETRO ÚNICAMENTE PARA VERIFICAR LA RESISTENCIA DEL SENSOR.  
 NO HAGA UN CORTO CON LAS TERMINALES.  
 LA RESISTENCIA DEL SENSOR MEDIDA EN LAS TERMINALES (C A S1,S2,S3) CON LA TEMPERATURA DEL MOTOR POR DEBAJO DE 60 °C (140 °F), DEBE ESTAR DENTRO DEL SIGUIENTE LÍMITE: 30 A 2400 OHMS.  
 CONSULTE EL BOLETIN COPELAND AE #10-1264.  
 EL MODULO TIENE UNA DEMORA DE DOS MINUTOS ANTES DE RESTABLECERSE, EN CASO DE QUE SE DISPARE EL PROTECTOR O SE PIERDA LA ENERGÍA EN EL MODULO.

**Discontinued  
 Wiring Diagram 1299 (Left Side)**



### PART WINDING START CONNECTED

CONTROL CIRCUIT VOLTAGE  
TENSION DU CIRCUIT DE CONTROLE  
VOLTAJE DEL CIRCUITO DE CONTROL

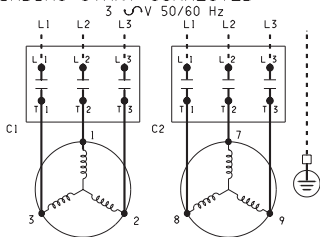
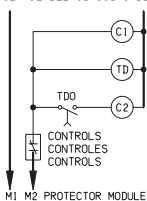

### ACROSS THE LINE CONNECTED

09-04 052-1299-00

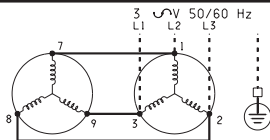

USE COPPER CONDUCTORS ONLY.  
USE MINIMUM 75 °C (167 °F) WIRE FOR AMPACITY DETERMINATION.  
USE THIS EQUIPMENT ON A GROUND SYSTEM ONLY.  
PRIMARY SINGLE PHASE FAILURE PROTECTION IS PROVIDED.  
PROTECTOR MODULE AND OPTIONAL CRANKCASE HEATER, FAN, OR CAPACITY CONTROL VALVE(S), MUST BE CONNECTED ONLY TO THEIR RATED VOLTAGE.  
OVERCURRENT PROTECTION DEVICE RATING AND TYPE MUST BE IN ACCORDANCE WITH REGULATORY AGENCY END PRODUCT APPROVALS-SEE SYSTEM NAMEPLATE.

UTILISER UNIQUEMENT DES CONDUCTEURS EN CUIVRE.  
UTILISER CET EQUIPEMENT UNIQUEMENT AVEC UN SYSTEME MIS A LA MASSE.  
UTILISER UN FIL DE 75 °C (167 °F) MINIMUM POUR DETERMINER LE COURANT ADMISSIBLE.  
LA PROTECTION CONTRE LES DEFAILLANCES PRIMAIRES A PHASE UNIQUE EST FOURNIE.  
PROTECTION INTERNE DU MOTEUR - ATTENDRE SUFFISAMMENT DE TEMPS AVANT LA REINITIALISATION.  
LORSQUE LE RECHAUFFEUR DU CARTER MOTEUR EST UTILISE, IL DOIT ETRE RACCORDE UNIQUEMENT A SA TENSION NOMINALE.  
LA VALEUR NOMINALE ET LE TYPE DU DISPOSITIF DE PROTECTION CONTRE LA SURINTENSITE DOIVENT ETRE CONFORMES AUX APPROBATIONS DE PRODUIT FINAL DES AGENCES DE REGLEMENTATION - VOIR LA PLAQUE SIGNALETIQUE DU SYSTEME.

UTILICE UNICAMENTE CONDUCTORES DE COBRE.  
USE ESTE EQUIPO UNICAMENTE EN UN SISTEMA CON TIERRAS.  
UTILICE CABLE CON UN MINIMO DE 75 °C (167 °F) PARA LA DETERMINACION DE LA CAPACIDAD EN AMPERES.  
INCLUDE PROTECCION PRIMARIA CONTRA FALLAS MONOFASICAS.  
PROTECCION INTERNA DEL MOTOR - DEJE PASAR UNOS MOMENTOS PARA QUE SE RESTABLEZCA.  
CUANDO SE UTILICE EL CALENTADOR DEL CARTER DEBE ESTAR CONECTADO UNICAMENTE AL VOLTAJE CORRESPONDIENTE A SU CAPACIDAD.  
LA CAPACIDAD Y TIPO DEL DISPOSITIVO DE PROTECCION DE SOBRECORRIENTE DEBEN ESTAR DE CONFORMIDAD CON LO APROBADO POR LA AGENCIA REGULADORA DE PRODUCTOS FINALES - CONSULTE LA PLACA CON LOS DATOS DEL SISTEMA.

**Discontinued**  
**Wiring Diagram 1299 (Right Side)**

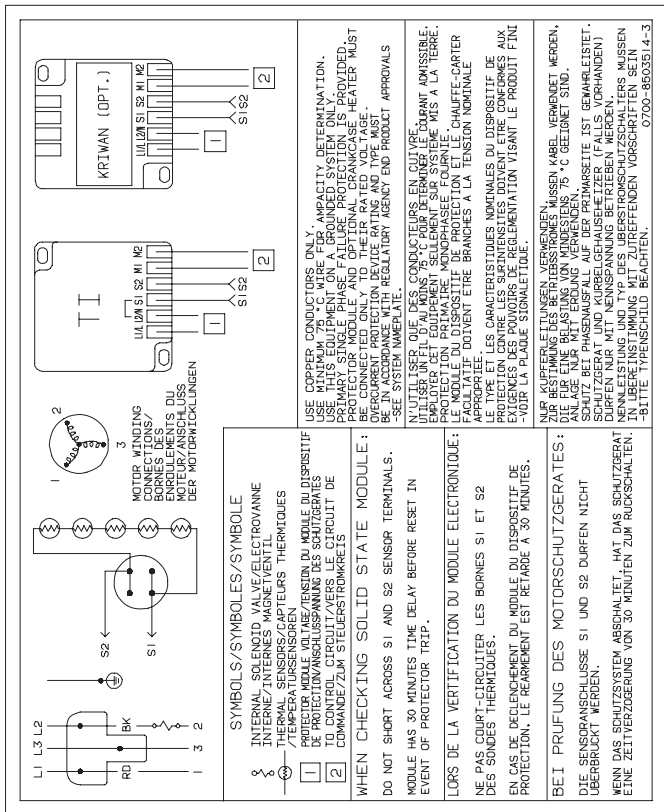

**Discontinued**  
**Wiring Diagram 1825, 0700-8503514**

# SECTION H

## ELECTRICAL TROUBLESHOOTING PROCEDURES

### TOPICS

If The Compressor Will Not Run..... H2

If The Compressor Starts But Trips Repeatedly ..... H5

If The Compressor Runs But Will Not Refrigerate.... H8

### CAUTION

*Before attempting any electrical trouble-shooting, make sure all grounds are connected and secure and there is ground continuity throughout the compressor system. Also ensure the compressor system is correctly grounded to the power supply. If you are not a qualified service person familiar with electrical troubleshooting techniques, DO NOT PROCEED until a qualified service person is available.*

## **IF THE COMPRESSOR WILL NOT RUN**

If a compressor fails to start and run properly, it is important that the compressor be tested to determine its condition. It is possible that external electrical components may be defective, the protector may be open, a safety device may be tripped, or other conditions may be preventing compressor operation. If the compressor is not the source of the malfunction, replacing the compressor will only result in the unnecessary expenditure of time and money while the basic problem remains.

1. If there is no voltage at the compressor terminals, follow the wiring diagram and check back from the compressor to the power supply to find where the circuit is interrupted.

Check the controls (low pressure, high pressure, thermostat, oil pressure safety, etc.) to see if the contact points are closed. If a contactor is used, check to see if the contacts are closed. Check for a blown fuse, open disconnect switch, or loose connections.

2. If voltage is available at the compressor terminals and it is below 90 percent of the nameplate voltage, it is possible the motor may not develop sufficient starting torque. Check to determine if wire sizes are adequate, electrical connections are loose, the circuit is overloaded, or if the power supply is adequate.
3. On units with single phase PSC motors, the suction and discharge pressures must be equalized before starting because of the low starting torque of the motor. Any change in the refrigerant metering device,

the addition of a drier, or other changes in the system components may delay pressure equalization and create difficulties. If PSC motor starting problems are being encountered, the addition of a hard start kit is recommended.

4. On single phase compressors, a defective start capacitor or relay may prevent the compressor from starting. If the compressor attempts to start, but is unable to do so or if there is a humming sound, check the relay to see if the relay contacts are damaged or its coil opened. The relay contacts should be closed during the initial starting cycle, but should open as the compressor comes up to speed.

Remove the wires from the start relay and check continuity through the relay coil. Replace the relay if there is no continuity. Use an ohmmeter to check across the relay contacts. Potential relay contacts are normally closed when the relay is not energized, while current relay contacts are normally open. If either gives an incorrect reading, replace the relay.

Do not attempt to run a compressor that has a capacitor that is bulging, leaking, or damaged. It must be replaced.

Make sure capacitors are electrically discharged before checking. Start capacitors should have bleed resistors. Check for continuity between the capacitor terminals and between the capacitor terminals and the case. Continuity indicates a short, and the capacitor should be replaced.

Substitute “a known to be good” start capacitor if available. If the compressor then starts and runs properly, replace the original start capacitor. On

PSC motors, substitute a “a known to be good” run capacitor if available. If the compressor then starts and run properly, replace the original run capacitor. If a capacitor tester is not available, an ohmmeter may be used to check run and start capacitors for shorts or open circuits. Use an ohmmeter set to its highest resistance scale and connect probes to capacitor terminals.

- a. With a good capacitor, the indicator should first move towards zero and then increase towards infinity.
  - b. If there is no movement of the ohmmeter indicator, an open circuit is indicated.
  - c. If the ohmmeter indicator moves to zero and remains there or on a low resistance reading, a short circuit is indicated. Defective capacitors should be replaced.
5. If the correct voltage is available at the compressor terminals and no current is drawn, remove power. Then remove all wires from the terminals and check for continuity through the motor winding. On single phase compressors, check for continuity from terminals C to R, and C to S and R to S. On three phase compressors, check for continuity between the terminals for connections to phases 1 and 2, 2 and 3, and 1 and 3. On compressors with line break inherent (internal) protectors, an open overload protector can cause a lack of continuity. If the compressor is warm, it may require consider-able time to cool down. If continuity cannot be established through all motor winding, the compressor should be replaced.

Check the motor for ground by means of a continuity check between the common terminal and the compressor shell. If there is a ground, replace the

compressor.

6. If the compressor has an external protector, check for continuity through the protector or protectors. All external and internal inherent protectors on Copelametic compressor can be replaced in the field. On larger compressors with thermostats, thermotectors, or solid state sensors in the motor windings; H,L,S protection (see Section D for compressor nomenclature), the internal protective devices cannot be replaced, and the compressor must be changed if the internal protectors are defective or damaged.

## **IF THE COMPRESSOR STARTS BUT TRIPS REPEATEDLY ON THE OVERLOAD PROTECTOR**

1. Check the compressor suction and discharge pressures while the compressor is operating. Be sure the refrigerant is compatible with the compressor and the temperature range is within the limitations of the compressor. If pressures are excessive, it may be necessary to clean the condenser, remove non-condensables from the system, add a crankcase pressure regulating valve, modify the system control, or take such other action as may be necessary to avoid excessive pressures. If the fan motor is three phase, make sure it is running in the right direction.

An excessively low suction pressure may indicate a loss of charge, and a suction gas cooled compressor may not be getting enough refrigerant vapor across the motor for proper cooling.

On units with no service gauge ports where pressures can't be checked, check the condenser to be sure it is

clean and fan is running. Excessive temperatures on suction and discharge lines may also indicate abnormal operating conditions.

2. Check the line voltage at the motor terminals while the compressor is operating. The voltage should be within 10 percent of the nameplate voltage rating. If outside those limits, the voltage supply must be brought within the proper range, or a compressor with different electrical characteristics must be used.
3. Check the amperage drawn while the compressor is operating. The amperage drawn should be within  $\pm 10$  percent of the published compressor curve data for the given pressures the compressor is operating under. High amperage can be caused by low voltage, high head pressure, high suction pressure, high oil level, mechanical compressor damage, defective run capacitors, or a defective starting relay.

On three phase compressors, check amperage in each line. One or two high amperage legs on a three phase motor indicates an unbalanced voltage supply, or a winding imbalance, which can cause motor overheating. If all three legs are not drawing approximately equal amperage, temporarily switch the leads to the motor to determine if the high leg stays with the line or stays with the terminal. If the high amperage reading stays with the line, the problem is in the line voltage supply. If the high amperage reading stays with the terminal, the problem is in the motor.

If the amperage is sufficiently unbalanced to cause a protector trip (approximately 10%) and the voltage supply is unbalanced, check with the power company to see if the condition can be corrected. If the voltage supply is balanced, indicating a defective motor phase,

H6 the compressor should be replaced.



4. Check for a defective run capacitor or starting relay in the same manner described in the previous section.
5. Check for wiring against the wiring diagram in the terminal box. On dual voltage motors, check the location of the terminal jumper bars to be sure phases are properly connected.
6. Overheating of the cylinders and head can be caused by a leaking valve plate or relief valve. To check, front seat the suction service valve and briefly pump the compressor into a vacuum. Stop the compressor and open the suction valve to allow the pressure on the suction gauge to build up to 0 psig. Again, close the valve. If the pressure on the gauge continues to increase steadily, the valve plate or relief valve is leaking. Remove the head and check the valve plate. Replace if necessary.
7. If all operating conditions are normal, the voltage supply at the compressor terminals balanced and within limits, the compressor crank-case temperature within normal limits, the amperage drawn within the specified range, the motor protector may be defective and should be replaced.

If the operating conditions are normal and the compressor is running excessively hot for no observable reason, or if the amperage drawn is above the normal range and sufficient to repeatedly trip the protector, the compressor has internal damage and should be replaced.

## **IF THE COMPRESSOR RUNS BUT WILL NOT REFRIGERATE**

1. Check the refrigerant charge and the operating pressures. Any abnormal operating conditions must be corrected.
2. If the suction pressure is high and the evaporator and condenser are functioning normally, check the compressor amperage draw. An amperage draw within  $\pm 5$  percent of published rating data, corrected for actual measured voltage, indicates normal compressor operation. An amperage draw considerably below the published rating data indicates a possible broken suction valve, discharge valve, broken connecting rod blown gasket, or worn rings in the compressor. Check the pistons and valve plate on an accessible compressor. If no other reason for lack of capacity and low amperage can be found, replace a welded compressor.

An amperage draw considerably above published rating data for the given operating pressures indicates possible bearing damage, and the compressor should be replaced.

Published compressor rating data for each model can be obtained by your Emerson Climate Technologies Wholesaler.

## **SECTION I**

### **IDENTIFYING COMPRESSOR FAILURES**

Most compressors fail due to system malfunctions which must be corrected to prevent repeat failures. After a compressor fails, field examination of the failed compressor often will reveal symptoms of system problems. Proper corrections will help eliminate future failures. Field examination does not affect warranty as long as all access plates and heads are reinstalled with all internal components put back inside the compressor.

<b>REFRIGERANT FLOODBACK</b>	<p>This is a result of liquid refrigerant returning to the compressor during the running cycle. The oil is diluted with refrigerant to the point it cannot properly lubricate the load bearing surfaces.</p>
<ul style="list-style-type: none"> <li>• <b>Air Cooled Compressors</b></li> <li>• Worn pistons and cylinders</li> <li>• No evidence of overheating</li> </ul>	<p>The liquid washes the oil off the pistons and cylinder walls during the suction stroke causing them to wear during the compression stroke.</p>

<ul style="list-style-type: none"> <li>• <b>Refrigerant Cooled Compressors</b></li> <li>• Center and rear bearings worn or seized</li> <li>• Dragging rotor, shorted stator</li> <li>• Progressively scored crankshaft</li> <li>• Worn or broken rods</li> </ul>	<p>The liquid dilutes the oil in the crankcase and the refrigerant rich oil will be pumped to the rods and the bearings through the crankshaft.</p> <p>As the refrigerant boils off, there will not be enough oil for sufficient lubrication at bearings furthest from the oil pump.</p> <p>The center and rear bearings may seize or may wear enough to allow the rotor to drop and drag on the stator causing a short.</p>
<ul style="list-style-type: none"> <li>• Corrections</li> </ul>	<ol style="list-style-type: none"> <li>1. Maintain proper evaporator and compressor superheat.</li> <li>2. Correct abnormal low load conditions.</li> <li>3. Install accumulators to stop uncontrolled liquid return.</li> </ol>

<p><b>FLOODED STARTS</b></p> <ul style="list-style-type: none"> <li>• Worn or scored rods or bearings</li> <li>• Rods broken from seizure</li> <li>• Erratic wear of crankshaft</li> </ul>	<p>This is the result of refrigerant migrating to the crankcase oil during the off cycle. When the compressor starts, the diluted oil cannot properly lubricate the load bearing surfaces causing an erratic wear or seizure pattern.</p>
<ul style="list-style-type: none"> <li>• Corrections</li> </ul>	<ol style="list-style-type: none"> <li>1. Locate compressor in warm ambient or install pump down.</li> <li>2. Check crankcase heater operation.</li> </ol>
<p><b>SLUGGING</b></p> <ul style="list-style-type: none"> <li>• Broken reeds, rods, or crankshaft</li> <li>• Loose or broken backer bolts</li> <li>• Blown head gaskets</li> </ul>	<p>This is the result of trying to compress liquid refrigerant and/or oil in the cylinders. Slugging is caused by floodback on air cooled compressors and severe flooded starts on refrigerant cooled compressors.</p>
<ul style="list-style-type: none"> <li>• Corrections</li> </ul>	<ol style="list-style-type: none"> <li>1. Maintain proper evaporator and compressor superheat.</li> <li>2. Correct abnormal low load conditions.</li> <li>3. Install accumulators to stop uncontrolled liquid return.</li> <li>4. Locate compressor in warm ambient or install pump down.</li> </ol>

<p><b>HIGH DISCHARGE TEMPERATURE</b></p> <ul style="list-style-type: none"> <li>• Discolored valve plate</li> <li>• Burned valve reeds</li> <li>• Worn pistons, rings, and cylinders</li> <li>• Stator spot burn from metal debris</li> </ul>	<p>This is the result of temperatures in the compressor head and cylinders becoming so hot that the oil loses its ability to lubricate properly. This causes rings, pistons, and cylinders to wear resulting in blow by, leaking valves, and metal debris in the oil.</p>
<ul style="list-style-type: none"> <li>• Corrections</li> </ul>	<ol style="list-style-type: none"> <li>1. Correct abnormal low load conditions.</li> <li>2. Correct high discharge pressure conditions.</li> <li>3. Insulate suction lines.</li> <li>4. Provide proper compressor cooling.</li> </ol>

<p><b>LOSS OF OIL</b></p> <ul style="list-style-type: none"> <li>• All rods and bearings worn or scored.</li> <li>• Crankshaft uniformly scored.</li> <li>• Rods broken from seizure.</li> <li>• Little or no oil in crankcase.</li> </ul>	<p>This is a result of insufficient oil in the crankcase to properly lubricate the load bearing surfaces. When there is not enough refrigerant mass flow in the system to return oil to the compressor as fast as it is pumped out, there will be a uniform wearing or scoring of all load bearing surfaces.</p>
--	--

<ul style="list-style-type: none"> <li>• Corrections</li> </ul>	<ol style="list-style-type: none"> <li>1. Check oil failure control operation if applicable.</li> <li>2. Check system refrigerant charge.</li> <li>3. Correct abnormally low load conditions or short cycling.</li> <li>4. Check for incorrect pipe sizes and/or oil traps.</li> <li>5. Check for inadequate defrosts.</li> </ol>
---	---

<p><b>ELECTRICAL</b></p>	<p>Many motors fail as a result of mechanical failure. Others are true electrical failures.</p>
--------------------------	---

<p><b>GENERAL OR UNIFORM BURN</b></p>	<p>All windings are uniformly overheated or burned.</p>
<ul style="list-style-type: none"> <li>• Corrections</li> </ul>	<ol style="list-style-type: none"> <li>1. Check for proper voltage.</li> <li>2. Check for unbalanced voltage.</li> <li>3. Check for inadequate motor cooling.</li> </ol>



<p><b>SINGLE PHASE BURN</b> Two phases of a three phase motor are overheated or burned.</p>	<p>This is the result of high current through two of the three phases.</p>
<p>• Corrections</p>	<ol style="list-style-type: none"> <li>1. Replace contactors.</li> <li>2. Check for proper motor protection.</li> </ol>

<p><b>HALF WINDING SINGLE PHASE BURN</b></p>	<p>Half of two phases of a three phase motor overheated or burned due to one contactor opening one of its contacts on a two contactor application.</p>
<p>• Correction</p>	<ol style="list-style-type: none"> <li>1. Replace contactors.</li> </ol>

<p><b>HALF WINDING BURN</b></p>	<p>Half of all phases of a two contactor three phase motor are over heated or burned.</p>
<p>• Corrections</p>	<ol style="list-style-type: none"> <li>1. Replace contactors</li> <li>2. Check for feedback circuit holding one contactor closed</li> </ol>

<b>PRIMARY SINGLE PHASE BURN</b>	Only one phase of a three phase motor is overheated or burned as the result of opening one phase on the primary side of a delta to wye transformer.
• Correction	1. Check primary side of a delta to wye mainpower transformer.

<b>START WINDING BURN</b>	Only the start winding of a single phase motor is uniformly overheated or burned.
• Corrections	<ol style="list-style-type: none"> <li>1. Check for proper wiring of compressor.</li> <li>2. Check starting capacitor and/or starting relay.</li> <li>3. Check compressor overloading.</li> </ol>

<b>SPOT BURN</b>	A localized burn within a winding, between windings, or from windings to ground.
• Corrections	1. If not the result of mechanical problems, check for spikes or surges of high current flow.

<b>SHORTED TERMINALS</b>	A breakdown of the insulation between terminals and compressor body.
• Correction	1. Check for over torquing of terminals.