

**Central
Hydraulics®**
Model 66150

HYDRAULIC WIRE CRIMPING TOOL

INSTRUCTIONS AND PRECAUTIONS



Distributed exclusively by Harbor Freight Tools®.
3491 Mission Oaks Blvd., Camarillo, CA 93011

Visit our website at: <http://www.harborfreight.com>

SAVE THESE INSTRUCTIONS.

READ ALL INSTRUCTIONS AND PRECAUTIONS.

Copyright© 2008 by Harbor Freight Tools®. All rights reserved. No portion of this document or any artwork contained herein may be reproduced in any shape or form without the express written consent of Harbor Freight Tools. Diagrams within this document may not be drawn proportionally. Due to continuing improvements, actual product may differ slightly from the product described herein. Tools required for assembly and service may not be included.

For technical questions or replacement parts, please call 1-800-444-3353.

UNPACKING

When unpacking, check to make sure that the item is intact and undamaged. If any parts are missing or broken, please call Harbor Freight Tools at the number shown on the cover of this document as soon as possible.

IMPORTANT SAFETY INFORMATION

1. Use this product only according to these instructions. *Improper use can create hazards.*
2. Wear ANSI-approved safety goggles and heavy duty work gloves during use.
3. **CAUTION!** Keep hands and fingers away from the Crimping Dies (7) when using this product. *This tool creates approximately eight tons of crimping force.*
4. **CAUTION!** Do not use extension for added leverage on the Fixed Handle (14) of this tool.
5. **WARNING!** NEVER attempt to crimp wires that are plugged into an outlet and are electrically charged (“live”).
6. Refer to the wire manufacturer’s instruction manual for specific wire crimping instructions prior to using this product.
7. Keep work area clean and well lit.
8. Do not overreach. Keep proper footing and balance at all times. *This enables better control of the product in unexpected situations.*
9. Keep bystanders out of the area during product assembly and use.
10. Do not assemble or operate when tired or when under the influence of drugs or medication.
11. This product is not a toy. *Do not allow children to play with or near this product.*
12. Use for intended purpose(s) only.
13. Inspect before use. *Do not use if parts are missing or damaged.*
14. Maintain product labels and nameplates. These carry important safety information. *If unreadable or missing, contact Harbor Freight Tools for a replacement.*

PRODUCT FEATURES

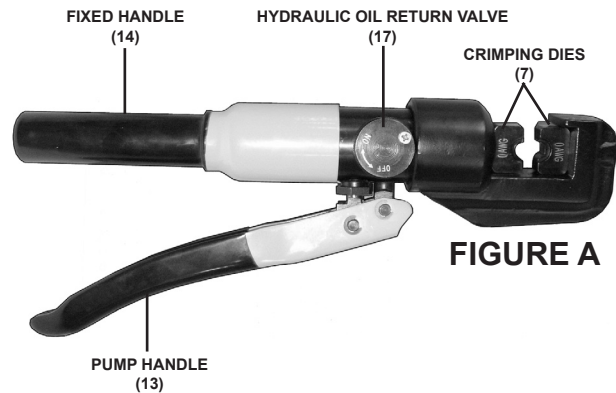

FIGURE A

OPERATING INSTRUCTIONS



Read the **ENTIRE IMPORTANT SAFETY INFORMATION** including all text under subheadings therein before set up or use of this product.

1. Check to make sure the Hydraulic Oil Return Valve (17) is in its “OFF” position. **(See Figure A.)**
2. Provided with this product are *nine* matching sets of Crimping Dies (7). Select the size of Dies (**AWG**) **00-0-2-4-6-7-8-10-12** you wish to use and insert them into the Pincers Head (8) of the tool. **(See Figure A.)**
3. Insert an electrical terminal (not included) onto the bare end of a wire. Then place the terminal with its wire between the set of Crimping Dies (7) on the tool. **(See Figure A.)**
4. Turn the Hydraulic Oil Return Valve (17) to its “ON” position. **(See Figure A.)**
5. Grip the tool firmly. Then slowly squeeze the Pump Handle (13) as many times as necessary to fully crimp the terminal onto the wire. **(See Figure A.)**
6. Once the terminal is crimped, turn the Hydraulic Oil Return Valve (17) to its “OFF” position to fully retract the Crimping Dies. Then remove the crimped assembly. **(See Figure A.)**
7. Make sure to store the Hydraulic Wire Crimping Tool in its Carrying Case and keep the Case in a clean, dry, safe location out of

reach of children and other unauthorized persons.



INSPECTION & CLEANING

WARNING

Procedures not specifically explained in this manual must be performed only by a qualified technician.

TO PREVENT SERIOUS INJURY FROM ACCIDENTAL OPERATION: Turn the Oil Return Valve (17) of the tool to its "OFF" position before performing any inspection, maintenance, or cleaning procedures.

TO PREVENT SERIOUS INJURY FROM TOOL FAILURE:

Do not use damaged equipment. If abnormal noise or vibration occurs, have the problem corrected before further use.

1. BEFORE EACH USE: Inspect the general condition of the Hydraulic Wire Crimping Tool. Check for misalignment or binding of moving parts, cracked or broken parts, and any other condition that may affect its safe operation.
2. TO REPLACE THE O-RINGS (3) AND PLASTIC RINGS (4): Only a qualified service technician should attempt to replace the O-Rings and/or Plastic Ring.
3. TO CLEAN THE HYDRAULIC WIRE CRIMPING TOOL: Use a clean cloth with a mild detergent. Then dry. Do not use solvents.

PARTS LIST & ASSEMBLY DIAGRAM

Part #	Description	Qty.	Part #	Description	Qty.
1	Hydraulic Cylinder	1	10	Handle Pin	2
2	Piston	1	11	Circlip	4
3	O-Ring (30 x 3.1)	2	12	Injection Piston	1
4	Plastic Ring (30 x 2)	1	13	Pump Handle	1
5	Piston Spring	1	14	Fixed Handle	1
6	Magnet	2	15	Faucet	1
7	Crimping Dies	18	16	Fount	1
8	Pincers Head	1	17	Hydraulic Oil Return Valve	1
9	Plank	1	18	Carrying Case	1

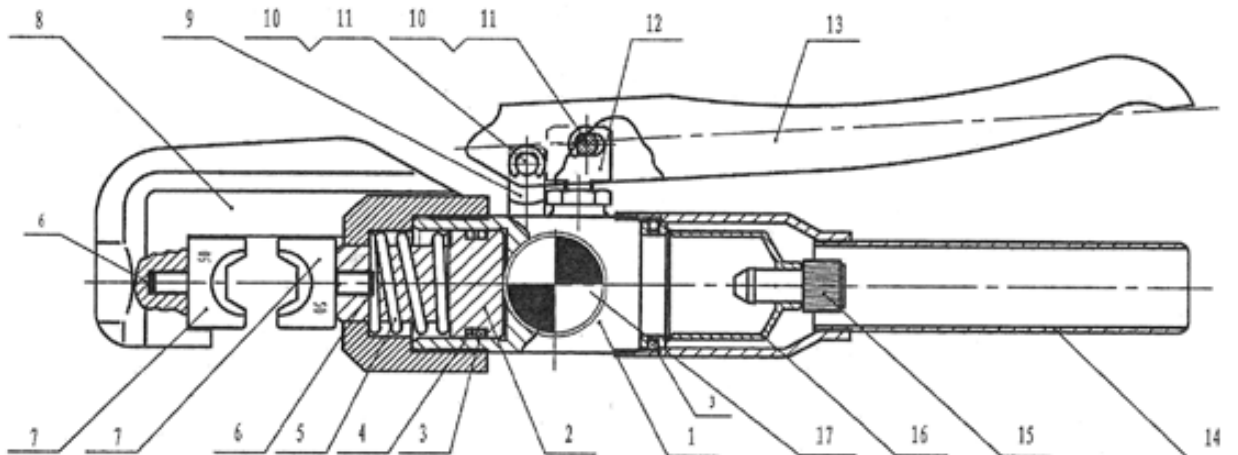

LIMITED 90 DAY WARRANTY

Harbor Freight Tools Co. makes every effort to assure that its products meet high quality and durability standards, and warrants to the original purchaser that this product is free from defects in materials and workmanship for the period of 90 days from the date of purchase. This warranty does not apply to damage due directly or indirectly, to misuse, abuse, negligence or accidents, repairs or alterations outside our facilities, criminal activity, improper installation, normal wear and tear, or to lack of maintenance. We shall in no event be liable for death, injuries to persons or property, or for incidental, contingent, special or consequential damages arising from the use of our product. Some states do not allow the exclusion or limitation of incidental or consequential damages, so the above limitation of exclusion may not apply to you. THIS WARRANTY IS EXPRESSLY IN LIEU OF ALL OTHER WARRANTIES, EXPRESS OR IMPLIED, INCLUDING THE WARRANTIES OF MERCHANTABILITY AND FITNESS.

To take advantage of this warranty, the product or part must be returned to us with transportation charges prepaid. Proof of purchase date and an explanation of the complaint must accompany the merchandise. If our inspection verifies the defect, we will either repair or replace the product at our election or we may elect to refund the purchase price if we cannot readily and quickly provide you with a replacement. We will return repaired products at our expense, but if we determine there is no defect, or that the defect resulted from causes not within the scope of our warranty, then you must bear the cost of returning the product.

This warranty gives you specific legal rights and you may also have other rights which vary from state to state.

3491 Mission Oaks Blvd. • PO Box 6009 • Camarillo, CA 93011 • (800) 444-3353

PLEASE READ THE FOLLOWING CAREFULLY

THE MANUFACTURER AND/OR DISTRIBUTOR HAS PROVIDED THE PARTS LIST AND ASSEMBLY DIAGRAM IN THIS DOCUMENT AS A REFERENCE TOOL ONLY. NEITHER THE MANUFACTURER OR DISTRIBUTOR MAKES ANY REPRESENTATION OR WARRANTY OF ANY KIND TO THE BUYER THAT HE OR SHE IS QUALIFIED TO MAKE ANY REPAIRS TO THE PRODUCT, OR THAT HE OR SHE IS QUALIFIED TO REPLACE ANY PARTS OF THE PRODUCT. IN FACT, THE MANUFACTURER AND/OR DISTRIBUTOR EXPRESSLY STATES THAT ALL REPAIRS AND PARTS REPLACEMENTS SHOULD BE UNDERTAKEN BY CERTIFIED AND LICENSED TECHNICIANS, AND NOT BY THE BUYER. THE BUYER ASSUMES ALL RISK AND LIABILITY ARISING OUT OF HIS OR HER REPAIRS TO THE ORIGINAL PRODUCT OR REPLACEMENT PARTS THERETO, OR ARISING OUT OF HIS OR HER INSTALLATION OF REPLACEMENT PARTS THERETO.

Record Serial Number Here: _____

Note: If product has no serial number, record month and year of purchase instead.

Note: Some parts are listed and shown for illustration purposes only, and are not available individually as replacement parts.