

## Terminal Pin Orientation

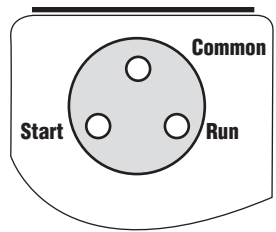

## Electrical Wiring Diagrams

### RSIR

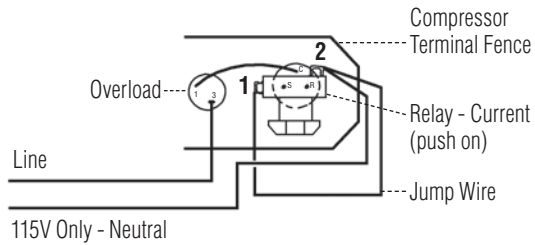

### CSIR

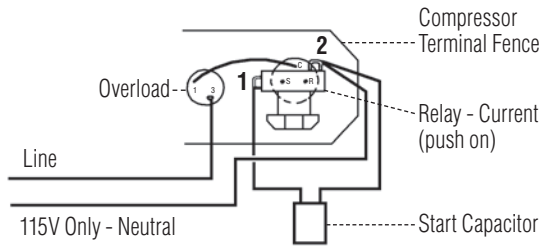

### ELECTRICAL COMPONENTS

Use only new electrical components specific for this compressor model.



Tecumseh

## AE<sup>2</sup> Compressor Installation Instructions

Typical CSIR Application

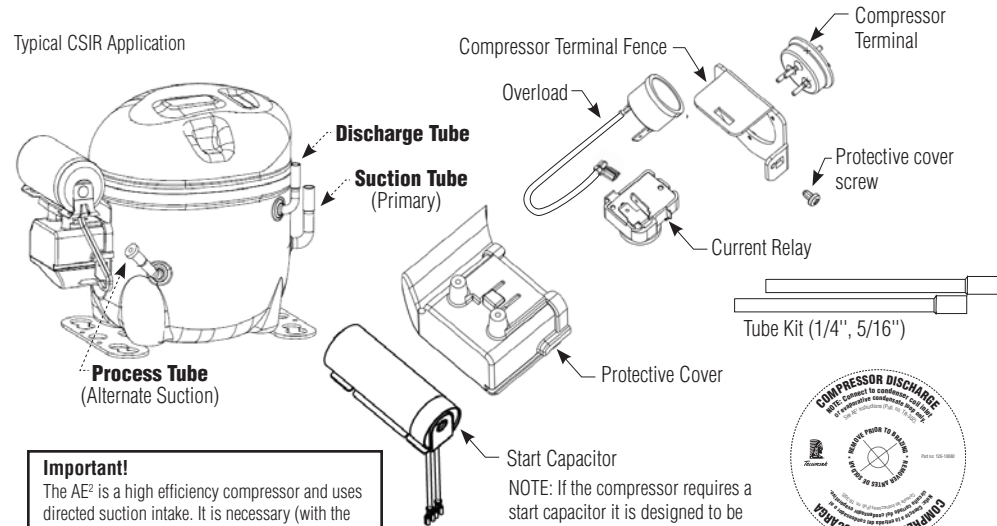

### Important!

The AE<sup>2</sup> is a high efficiency compressor and uses directed suction intake. It is necessary (with the exception of ice cube machine applications) to use the designated suction tube.  
For ice cube machines: Tecumseh recommends to use the process (alternate suction tube) as the suction tube.

Start Capacitor

NOTE: If the compressor requires a start capacitor it is designed to be mounted on the protective cover. Use two (2) washer head screws to attach the capacitor mounting bracket to the protective cover. The capacitor mounting bracket will flex to allow the removal or assembly of the start capacitor.



Discharge Tube Hang Tag

### Removal of the Protective Cover

- 1 Use a Phillips screwdriver, remove the protective cover screw.
- 2 Use a flat-head screwdriver, lift up slightly on the flange on the top side of the protective cover to release the cover and,
- 3 At the same time, from both sides of the cover, pull firmly away from the compressor housing to remove the protective cover.

### WARNING

Never service, repair, or troubleshoot unless you are qualified to perform these functions. Improper servicing can lead to serious injury or death from fire, electrical shock, or explosion.

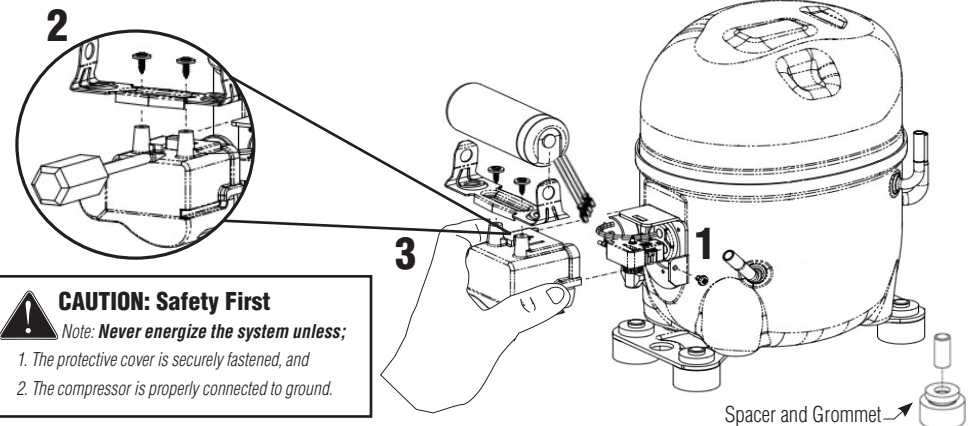

### CAUTION: Safety First

Note: **Never energize the system unless;**

1. The protective cover is securely fastened, and
2. The compressor is properly connected to ground.



## GENERAL INSTALLATION INSTRUCTIONS

- \* Prior to removal of current compressor please refer to Tecumseh's Service Handbook to verify compressor requires replacement. The Service Handbook is available online at [www.tecumseh.com](http://www.tecumseh.com).
- \* Tubing sizes and orientation may vary between compressors and applications. For your ease of installation, we have included copper tubing kit swaged at one end in a lengths of 1/4" OD and 5/16" OD.
- \* Use only electrical start components supplied with this replacement compressor.  
**Do Not Reuse Electrical Components! Use Only New Electrical Components.**
- \* Tecumseh recommends using provided replacement mounting grommets and hardware.
- \* Install a properly sized filter-drier for the system being serviced.
- \* Evacuate to a minimum of 500 microns. Always use a vacuum gauge to measure vacuum levels.



### CAUTION: SAFETY FIRST

- \* DO NOT INSTALL, service, repair, or troubleshoot an air conditioning or refrigeration system without proper certification and approval from authorities (Local, State, Federal).
- \* YOU MUST have the necessary knowledge, training and equipment.
- \* DISCONNECT ELECTRICAL POWER before removing the protective cover of any electrical terminal.
- \* DO NOT RE-CONNECT electrical power unless the protective covers of all electrical terminals are in place and securely fastened.
- \* DO NOT OPERATE compressor or connect electrical power, unless it is connected to ground.
- \* DO NOT RESET A BREAKER or replace a fuse without first checking for ground fault (short circuit to ground).
- \* An open fuse or tripped circuit breaker is a strong indication of a ground fault, also known as a short circuit to ground.
- \* If a ground fault does exist, keep the power off and find and repair. Use only a Mega Ohmmeter ("megger") or a Hi-potential ground tester ("Hi-Pot") to check for a ground fault. A conventional ohmmeter will not reliably detect an insulation breakdown causing the ground fault.
- \* Never expose system to leak test pressures greater than 150 psig (11.4 bar abs).
- \* Never overcharge system with refrigerant. Overcharging with refrigerant may lead to excessive pressures and rupture of terminal block may occur. Always use proper charging techniques and limit charge amounts to those specified on the system equipment serial label or in the original equipment manufacturer's service information.
- \* Contact with refrigerant, mixtures of refrigerant and oil, or other chemicals can cause a variety of injuries including burns and frostbite.
- \* Oil and refrigerant can spray from compressor electrical terminals and be ignited by electricity or other sources of ignition causing serious INJURY or DEATH.

## NEW INSTALLATION TIPS

- \* Upon receipt of your new compressor check for damage from shipping. Report any damage immediately to your local Tecumseh dealer.
- \* Check the name plate for correct voltage, phase, frequency, and refrigerant for the intended use BEFORE installation.
- \* Check compressor windings for correct ohm's readings and short circuit to ground BEFORE installation. Keep the following in mind:
  - Power to unit must be off
  - Removing wires to expose terminals can lead to mis-wiring, replace correctly
  - Securely replace protective cover

- \* Warning labels are provided to inform and protect persons servicing Tecumseh equipment. Care must be taken not to damage or destroy labels during installation. Damaged or missing labels should be replaced with approved labels from your Tecumseh dealer.
- \* This compressor is shipped with a holding charge of nitrogen or dry air. Remove the holding charge only after the equipment has been installed with connecting tubing and a new filter-drier installed. Purge the holding charge thru a service port. DO NOT leave the unit open to the atmosphere for an extended period of time, to do so will contaminate the oil and cause excessive evacuation time, and could cause premature failure.
- \* Be sure to use clean, refrigeration tubing with both ends sealed.
- \* Remove discharge tube hang tag prior to brazing. Cut, form and braze tubes carefully to avoid getting dirt and/or metal filings into the lines. When sizing suction and liquid lines, consult the refrigerant line sizing section of the Tecumseh Hermetic Service Handbook, or use the Tecumseh refrigerant line sizing app located at <http://boxload.tecumseh.com/> Whenever possible, pitch the suction line downward in the direction of flow, approximately 1/2" for each 10 ft length, to aid in oil drainage. Avoid line lengths in excess of 100 ft. Contact Tecumseh Technical Service for assistance.
- \* When you open the system, complete the service operation as quickly as possible so it will not be exposed to the air longer than necessary.
- \* Once all connections have been made, leak test with regulated dry nitrogen or other approved gas to a pressure not to exceed 150 psig (11.4 bar abs). Repair any leaks and leak test again.
- \* When system is leak free, connect a vacuum pump capable of at least 500 microns vacuum to both sides of the system. Evacuate to at least 500 microns for a minimum of 30 min. Vacuum levels should be measured with an electronic gauge.
- \* Do not operate the compressor without a charge in the system. Operating the compressor without a charge in the system can damage the hermetic terminals. To avoid serious injury or death from terminal venting with ignition, DO NOT energize the compressor unless the protective cover is securely fastened.
- \* CAUTION!!! Only use refrigerant indicated on serial label when charging the system. Using a different refrigerant can lead to excessive system pressure and/or an explosion. Use of a refrigerant other than the serial label refrigerant will void the warranty.

## COMPRESSOR REPLACEMENT TIPS

- \* Disconnect all electrical power supplies to the system, making sure all power legs are open. (note: The system may have more than one power supply.)
- \* Be sure all refrigerant is recovered before removing the compressor. Attempting to remove the compressor before removing all refrigerant from the system can cause a sudden release of refrigerant and oil. Among other things, this can cause a variety of injuries including burns and frostbite, a fire, and expose the service person to toxic gas.
- \* Install a properly sized filter-drier for the system being serviced.
- \* Use only regulated dry nitrogen or dry nitrogen with trace amounts of the serial label refrigerant to purge and/or leak test the system to a pressure not to exceed 150 psig (11.4 bar abs).

## QUESTIONS AND SUPPORT

**Tecumseh Tech Support: 800.211.3427 or Email: [technical.service@tecumseh.com](mailto:technical.service@tecumseh.com)**

Tecumseh reserves the right to change any information in this publication at any time.

This document is not intended to replace the training required for professional service personnel, or replace other information available from refrigeration and air conditioning equipment manufacturers. The information in this document is intended to assist service personnel in safely installing and servicing Tecumseh AE<sup>2</sup> compressor. Mounting and tubing connections are likely to differ from original installation. Careful review of current application requirements is essential. IT IS THE RESPONSIBILITY OF THE SERVICE PERSON TO ASSURE THEY HAVE PURCHASED A REPLACEMENT PRODUCT WHICH MEETS THE NEED OF THE APPLICATION. Failure to do so may result in misapplication requiring immediate or subsequent additional compressor replacement.

