

---

# Uses and Misuses of Duct Board: Understanding the New High-Performance Materials

Brad Oberg, AIA

## ABSTRACT

*This paper is based on a white paper developed at the author's firm, which discusses the appropriate uses for fibrous glass duct board for residential HVAC applications. Here the author describes the characteristics and benefits of fibrous glass duct board and addresses issues specific to fibrous glass duct construction, including the concern that fiberglass ducts collect water and support growth of mold.*

---

## INTRODUCTION

High-performance homes inherently have green characteristics because, when appropriately engineered, they use less material, consume less energy, and are more durable, comfortable, and safe. Because duct board already has thermal insulation and does not require additional external insulation as metal duct does, it provides a good option for developing duct systems for high-performance homes. However, there has been resistance to the use of duct board in residential applications due to concerns about moisture retention and mold growth. Uncoated or unfaced duct board has high moisture absorbing potential and a large amount of fiber surface area that increases surface friction, but newer generation products that include a matte coating or laminated facing on the inside face of the board reduce these negative characteristics.

Why is an engineered duct system that incorporates high-quality products important to system and home performance? Homes built to code require heating and cooling air capacities as high as 1 cfm per square foot of floor area. With even moderate influence of newer codes, and the introduction of better window systems, double glazing, and low-emmissivity coatings, a home built to code can use as little as 0.4 cfm per square foot of floor area. Homes built to Energy Star® levels, or meeting state energy codes such as California Title 24, or

those in Wisconsin, New York, and Florida, can require as little as 0.2 cfm of air delivery per square foot of floor area.

These reduced airflow demands allow the use of smaller ducts but also reduce the margin for error in duct installation. Critical performance needs of the distribution system are airtightness and an engineered environment with predictable performance characteristics. Sheet metal ducts are a consistent engineering material with well-documented flow characteristics; however, they are difficult to adequately seal, require additional insulation, and are not easily fabricated in the field. Flexible duct materials are pre-insulated and, with care, can be sealed adequately but are inconsistent in flow characteristics because of inconsistent care in installation. Duct board trunks and large branches may be field- or shop-fabricated to create pre-insulated airtight duct sections with consistent and predictable flow characteristics.

## QUALITY AND PERFORMANCE CHANGES IN CURRENT PRODUCTS

The latest generation of duct boards are semi-structural insulated fibrous glass boards, with a vapor retarder facing on the exterior and a laminated matte liner in the interior, providing a smooth cleanable airstream face on the air side. In recent years, all of the major duct board producers have added coated or laminated products to their lines, while maintaining the

---

**Brad Oberg** is the co-founder and chief technology officer of IBACOS, Inc., Pittsburgh, Pa.

basic duct board products. Fibrous glass ducts now provide an engineered air delivery environment with predictable design characteristics of structure, pressures, friction, and thermal properties.

## **KEY CRITERIA FOR SELECTING A DUCT CONSTRUCTION METHOD**

### **Physical Strength: Self-Supporting Structure and High Overpressure Capacity**

The following test results have been documented in the “Fibrous Glass HVAC Duct Systems: Proven Performance” report by North American Insulation Manufacturers Association (NAIMA 1996). The tests were performed by NAIMA using Underwriters’ Laboratories’ (UL) test procedures for structural integrity, where duct samples were subjected to a variety of tests. Based on test data, fibrous glass duct board is a strong and durable material system.

In one test procedure where a duct sample is subjected to the impact of a two-pound rod dropped in several locations, including joints, fibrous glass duct was found to be puncture-resistant. In another test, a duct span was subjected to static load. The test result was that the structural integrity of fibrous glass duct exceeds that required in actual installations. In a third test, where sealed duct sections are subjected to 2.5 times rated positive and negative pressures, fibrous glass ducts successfully withstood positive and negative test pressure 2.5 times higher than rated operating pressures. This surpasses the 50% margin required in most installations.

### **System Application**

Fibrous glass duct board may be used in a variety of residential purposes. It can be used in applications ranging from straight duct sections, elbows, and tees, to offsets and other system elements. There are some specific areas within the duct system where fibrous glass duct board may not always be the recommended product because of the high potential for exposure to water. These applications will be discussed in detail in the “Issues Specific to Fibrous Glass Duct Construction” section. Also, fibrous glass duct board should not be used in concrete, buried below grade, or any other location where it may be directly exposed to weather or physical abuse.

### **Pressure Loss and Sizing**

When sizing fibrous glass duct board systems, there are two key considerations. First, make sure that the fabrication drawings clearly state interior dimensions, as many new fabricators will measure to the outside and have restricted flow. Second, design the ducts for the appropriate friction rate associated with the material specified. The new duct boards all have a facing and have significantly reduced the friction of the air side finish of the duct board.

Standard uncoated fibrous glass duct board is classified as a medium-rough surface by ASHRAE (2001), while laminated and coated fibrous glass duct boards have surfaces that

are less rough. When sizing fibrous glass duct board, the manufacturer’s literature and design criteria should always be consulted. IBACOS has created a set of friction curves that we use to design the duct systems. These three curves are shown in Figure 1. The blue curve is the sheet metal curve, the green curve is that of unfaced or finished duct board, and the yellow is our best estimate of the design values for the laminate-faced new generation duct board product. Sheet metal friction is based on surface and joint configurations. The uncoated duct board, classified as a medium roughness, is controlled by higher surface friction. The faced/coated duct board behaves only slightly rougher than sheet metal but does not have joint interruptions, so we estimated it as overall slightly 5% rougher.

### **Installation and Fittings**

Fibrous duct construction should conform to the Sheet Metal and Air Conditioning Contractors' National Association (SMACNA) Fibrous Glass Duct Construction Standards or NAIMA Fibrous Glass Duct Construction Standards and include predictable cross sections and transitions, as well as traditional take-offs and pressure regain regions.

Installation of the supply trunk and main return duct are done using straight duct modules fabricated from flat sections of fibrous glass duct board. Joints and longitudinal seams need to be sealed using a UL 181 approved closure system, as outlined in *NAIMA’S Fibrous Glass Duct Construction Standards*, 2nd edition (NAIMA 1997). Fibrous glass ducts are light and can be supported with a typical number of hangers, again following SMACNA or NAIMA standards.

Attachment of insulated flex duct to fibrous glass ducts is as simple as spinning in a collar, sealing the pressure liner, and securing the vapor-retarding covering to the facing of the fibrous glass duct board.

When building elbows or installing volume or zoning dampers, adequate support must be provided. Exterior bracing sections may be added, or short sections of metal frame may be inserted inside the duct. All but heavy accessories may be supported within the fibrous glass duct board sections. These accessories can still be used with fibrous glass duct board but will simply need to be independently supported, as is the case with all duct material. Turning vanes and duct offsets are achieved without added bracing.

### **Condensation Control**

In insulated duct systems, condensation on the surface of the ductwork is a concern during the cooling and heating seasons. The inherent attributes of ductwork constructed of fibrous glass duct board provide solutions to these conditions:

1. During heating mode, the air inside the ductwork is hot and dry with little potential for condensation on the backside of the exterior surface. In northern attics, additional insulation should be considered outside the duct board structure itself, equal to the insulation value of the duct board. If the duct serves cooling only, the ducts should be sealed during winter operation to minimize condensation.

## Friction Comparison

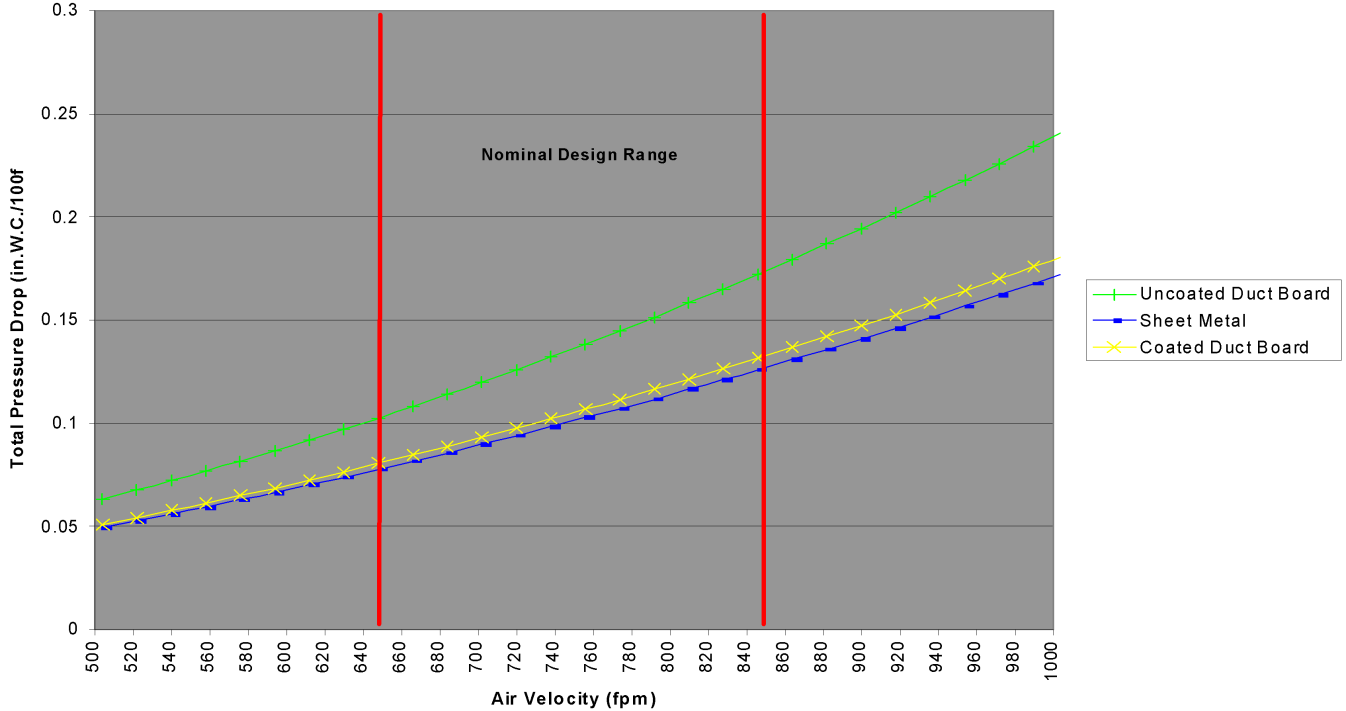

Figure 1 Duct material friction comparison.

- When ductwork is located in an unconditioned space during heating mode, all of the energy is focused on drying, and there is little potential for condensation except in far northern climates. Additional insulation outside the duct board will be needed if interior RH is maintained at levels exceeding 50%, or where ducts are used only for cooling, and air is not circulated through the ducts in the winter.
- During cooling mode, condensation potential from the interior is limited because the saturated air exiting the cooling coil increases in temperature, which increases the capacity to hold moisture and the relative humidity drops, again limiting the potential for condensation.
- When ductwork is located in an unconditioned space during cooling mode, an adequate thickness of insulation will prevent the cold interior air from lowering the exterior surface of the fibrous glass duct board to a temperature suitable for condensation. This is the one mode where condensation can occur on the exterior of the ducts, and similar performance can be seen in fibrous glass duct board as well as insulated sheet metal ducts. Humid attic air will condense on cold surfaces. Increasing the insulation levels will raise the exterior surface temperature, reducing condensation. Southern homes in hot and humid environments with attics that are vented to exterior humid conditions may need to use an R-8.5 insulation level, accomplished by fabricating with

thicker duct board, not to conserve cooling energy, but to control condensation. If the attics are not vented then the dew point will be closer to the conditioned space and additional insulation will not be needed.

### Mold Growth Potential

According to NAIMA (1996) studies, it has been incorrectly thought that microbes will use the resin bonding and the glass fibers in fibrous glass duct board as a food source to support mold growth. Further, the glass fibers that make up the core of fibrous glass duct board are inorganic and, therefore, do not support mold growth. Many fibrous glass duct boards are now produced with antimicrobial agents integrated into the surface to act as a preventive agent against the growth of mold on the airstream surface. In fact, the dust that accumulates in ductwork during normal system operation provides the food source to support mold growth. Fibrous glass duct board has passed the UL 181 tests for long-term durability. Using the UL test procedure, duct samples containing mold mycelia and bread spores were placed in a dark chamber with high humidity for 60 days. The test result confirmed that fibrous glass duct insulations do not support microbial growth.

Mold growth studies conducted by researchers Thomann and Tulis (1996) show that mold growth is not surface specific. Under similar conditions of temperature, water, and food (dust) availability, both fibrous glass duct board and galva-

nized metal ducts showed equal mold growth. Studies have shown that the presence of available water and food (dust) becomes the determining factor to mold growth, not the type of duct material. Researchers found that fungal growth was rarely observed on many different duct surfaces subjected to high-humidity air, even when exposed over extended periods of time. In contrast, fungal amplification was regularly observed where liquid water was introduced to the duct surfaces. Therefore, wherever liquid water was introduced to the system, microbial growth was observed on all surface types of ducts, including circular metal “flex” duct, the flat surfaces of metal ducts, plastic-lined flex duct, caulks and sealant, conditioning coils, metal sound attenuators, and internal duct liners.

Thomann and Tulis (1996) conclude that incidents of mold growth in ducts are not a duct material issue, but, rather, an operation and maintenance issue of the space conditioning system. Because eliminating all dust from the equation is impossible, it is imperative that the system be properly designed to eliminate water.

Operation of the HVAC systems may create conditions that are suitable for mold growth on any duct material. HVAC ducts fabricated from all types of materials will become contaminated with dust and dirt from normal system operation. Air carrying dust is continually returned through the system and filtration systems. Even when properly maintained, HVAC and filtration systems do not stop all of this dust transfer from occurring. This dust will continually travel through the HVAC unit and the ductwork and will be deposited throughout the systems. Dust and dirt collect in areas of roughness. Unfaced duct board, poorly fabricated joints between duct sections of any materials, and areas of low pressure found with abrupt increase or decrease in size will collect more dirt than smooth well-fabricated ducts. This dust and dirt provides the food source for mold growth when combined with water. For this reason, it is essential that HVAC systems be designed and fabricated with care and that ductwork be inspected yearly and cleaned as needed.

## Leakage

According to the International Code Council (ICC 2000), all joints and seams should be made airtight by means of an approved closure system. Closure systems used with rigid fibrous glass duct systems should comply with UL 181A.

Leakage of conditioned air out of supply ducts or non-conditioned air into return ducts can severely compromise the overall energy efficiency of an HVAC system. Fibrous glass duct systems, when installed according to manufacturer’s recommendations, have minimal leakage. In a NAIMA test using a UL test procedure (NAIMA 1996), a flow meter measured leakage under positive pressure in an eight-foot fibrous glass duct section with both ends capped. A test was conducted on duct samples already exposed to static load, impact, pressure, or collapse tests. The result was that leakage in fibrous glass ducts does not exceed 20 times the static

volume of the duct in a one-hour period, the maximum permitted by the UL standard.

The fact that the trunks and continuous sections of duct can be made tight does not eliminate the need to properly fabricate connections and transitions. Metal collars should be a spin-in type, designed for fibrous glass ductwork, and the collar should be sealed with mastic to the facing of the duct-board. Duct board sections are fabricated into full cross sections and are tested to two-and-a-half times the rated operating pressure of 2 in. w.c. (498 Pa). In overpressure, the seal may not slip, and, in underpressure, the cross section may not collapse more than 20% of the cross section.

## Acoustic Performance

Noise in ductwork is created by the furnace blower, the blower turbulence, mechanical noise, and blower and motor vibration, as well as from the turbulence that is created from the movement of air through the ductwork. The attributes of fibrous glass duct board reduce these noises more than sheet metal when common design techniques are used. (Sheet metal can regenerate or amplify the noise and transmits vibration to the house structure via hangers and other contact points.)

Based on NAIMA (2002) studies, fibrous glass duct board reduces the noise associated with the blower, as well as the air turbulence within the duct. Also, fibrous glass duct board does not create duct noise by popping or booming due to expansion and contraction. It also helps to reduce room-to-room noise transfer.

## Cleaning

As NAIMA (1998) reports, fibrous glass duct board may be cleaned with conventional methods. The three most popular methods are air sweeping, vacuuming, and rotary brush. Never use steam or any cleaning method that involves water to clean fibrous glass duct board. With air sweeping, a nozzle is inserted into the duct, and the accumulated dust is lifted by a compressed airstream and carried away by a general flow of air induced by a vacuum downstream. Contact cleaning is achieved by a vacuum cleaner with a low stiffness brush used to vacuum the inside surface of the duct. With a low stiffness rotary brush, a powered head is inserted into the duct with long bristles that lift the dirt by direct impact on the surface.

The concern about duct cleaning is the issue of fiber erosion. However, the only aggressive method is the rotary brush, where poor attention may allow the brush to stay in one location too long and damage the surface. The newest generation of internally faced products addresses this concern, but also ensuring that the brush is kept moving and using a softer whisker brush would eliminate these issues, according to NAIMA (1998).

Access to the duct for cleaning is achieved by using a knife to cut access panels into the fibrous glass duct board. There are several different ways to cut these accesses, and each cut piece can easily be replaced and sealed back into the duct after the cleaning is complete. Guidelines are available from

the “NAIMA Cleaning Fibrous Glass Insulated Air Duct Systems Recommended Practice” brochure (NAIMA 1998).

If adequate care is given to keeping ductwork clean during the construction process, fibrous glass duct board should not need initial cleaning. For off-site fabrication, it is important that the fibrous glass duct board be swept out after fabrication to remove any loose fibers that may be left inside the duct from cutting the fibrous glass duct board. Care should be taken during transportation of the duct fabricated off-site to keep it clean and free of contaminants. It is essential that the ducts be protected and kept dry during transit so as to prevent moisture entering the duct system prior to its installation. If the fibrous glass duct board is fabricated on the job site, it will also need to be properly cleaned out prior to it being installed. The additional challenge of on-site fabrication is that the work area must be kept clean and dry throughout the process. This is sometimes difficult on a construction site, but it is essential for ensuring that the integrity of the fibrous glass duct board be maintained prior to its installation.

For condensation control according to NAIMA (1996), the fibrous glass duct’s outer jacket acts as a vapor retarder to help control moisture condensation in the air-handling system, thus reducing the opportunity for water damage or for microbial growth and amplification.

## ISSUES SPECIFIC TO FIBROUS GLASS DUCT CONSTRUCTION

One of the concerns with fibrous glass duct board is its interior surface. Its interior composition of glass fibers is rough when compared to smooth steel and has caused many industry contractors to question whether fibrous glass duct board is a safe and durable option. Testing using UL test procedures, however, has proven that fibrous glass duct board is a safe and durable duct fabrication material. Discussed below are issues specific to fibrous glass duct construction, as well as testing results and industry research that address these concerns. This section also discusses, in particular, horizontal air-handling units, downflow systems, and bottom return systems, which require careful attention in installation.

### Proper Installation and Maintenance of Air-Handling Units

If air-handling systems are properly installed and maintained, the availability of water inside the ductwork is remote. Frequent and significant amounts of surface water does not collect in ductwork from condensation. Water does collect from poor drainage of condensate and blow-off from a coil. Under normal conditions, the velocity of air passing through the coil is low enough to not lift off water droplets from the wet surface of a cooling coil. As the air velocity across the coil increases, water drops may be ripped free and carried down the supply airstream to ductwork beyond. Several design and maintenance conditions could result in conditions that result in water blow-off. These conditions are independent of duct

material construction and result in similar wetting of both metal and fibrous glass ducts:

1. ***Improper sizing of the cooling coil.*** When the cooling coil is undersized, when compared to the furnace, it reduces the free area and increases the velocity of the air as it goes through the coil. This condition creates the potential for blow-off.
2. ***Restriction of airflow, allowing buildup of ice on the coil.*** This can occur with an improperly sized cooling coil and/or restrictive ductwork in the plenum. These conditions restrict airflow across the cooling coil. When the cooling coil does not have adequate airflow across it, it becomes too cold, and ice buildup occurs.
3. ***Restriction in free area of the coil due to dirt buildup on the coil surface.*** This results from lack of proper maintenance on the system over time, allowing dirt to build up and reduce free area. This reduction of free area creates increased velocities and potential for ice buildup.
4. ***Air bypassing the coil, picking up water from a poorly drained condensate pan.*** When the coil is restricted, particularly in horizontal flow units, the air is delivered past the coil and picks water up from the pan. In severe conditions, the pan simply overflows.

Wetting of duct surfaces in the return plenum of upflow systems can also be a problem. Many styles of air-handling units have supplied return air either through the sides of the fan section or through the bottom of the unit, such as when the unit is set over a return box plenum. Wetting of these plenums directly below the air-handling unit occurs in several ways.

1. After a cooling cycle, cool air drops off the coil above and chills surfaces. In poorly sealed ductwork, humid exterior air can be introduced and cause some condensation. The solution is to use sealed ductwork on both supply and return and to build in a vapor retarder and insulation to isolate the cool interior from a moist exterior. Fibrous glass duct board does this as an inherent aspect, while metal duct requires the addition of well-executed insulation and vapor retarder application. The use of framing materials and gypsum wall-board should be avoided in upflow return plenums, as they cannot be made airtight or insulated to control vapor access to cold surfaces.
2. Inadequate maintenance or drainage of the condensate pan can also result in flooding of the return plenum. Provision for coil maintenance and assurance of adequate drainage is required for elimination of these issues.
3. Fall back of suspended water droplets. Water droplets may be lifted off the coil for the same reasons as described for wetting of supply ducts downstream from air-handling units. In upflow systems, the droplet will build up and wet the sides of the coil plenum and run down into the blower section of the system, eventually dropping into the plenum. This only happens with poorly designed or maintained systems. Construction of the return plenum from well-

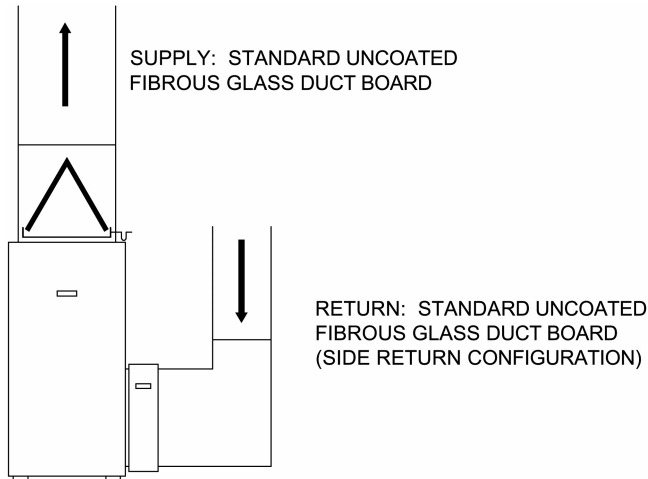

**Figure 2** Construction details for an upflow configuration and an upflow configuration with a side return.

sealed and insulated metal, or using faced or coated fibrous glass duct board, will allow a greater opportunity to identify and correct the air-handling unit issue before other damage occurs.

**Application and Construction Detail: Upflow Condition, Side Return.** While upflow systems may still experience wetting due to improper design, they are not as susceptible as the other two configurations because gravity does not play a significant role. As shown in Figure 2, in an up-flow configuration, standard uncoated fibrous glass duct board may be used adjacent to the coil.

In an upflow configuration with a side return, as detailed in Figure 2, standard uncoated fibrous glass duct board may be used in the return adjacent to the furnace fan.

**Application and Construction Detail: Upflow Condition, Bottom Return.** For upflow furnaces with a bottom return, sheet metal should be used in the return ductwork directly below the unit, as presented in Figure 3. In addition, the return boot should also be fabricated from sheet metal to prevent any water that may enter the system from collecting in the boot. From the return boot, standard uncoated fibrous glass duct board may be used for the rest of the return.

**Application and Construction Detail: Horizontal Flow Condition.** In horizontal-flow units, the force of gravity is neutral relative to the airflow, but the force of the airflow is enough to push unwanted condensate into the ductwork. This water may show up as a leak in addition to wetting the duct.

There are two options that may be considered, as shown in Figure 4. Metal duct, installed so that it slopes back to the furnace, may be used for the first four feet of duct adjacent to the coil. To prevent air infiltration, all seams and connections must be sealed with a UL 181 approved closure system at ductwork joints. In addition, exterior insulation is to be used on the

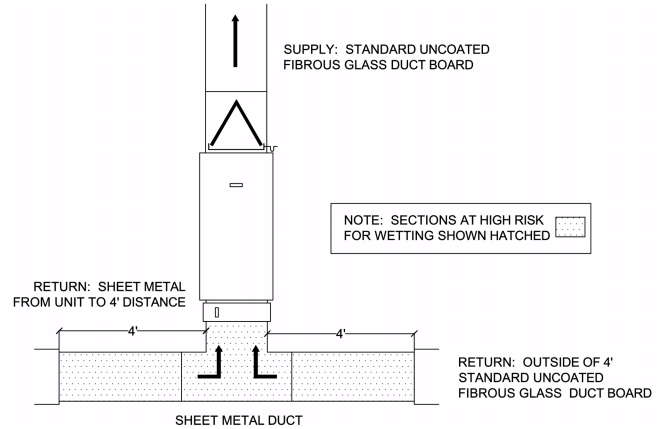

**Figure 3** Construction detail for upflow furnaces with a bottom return.

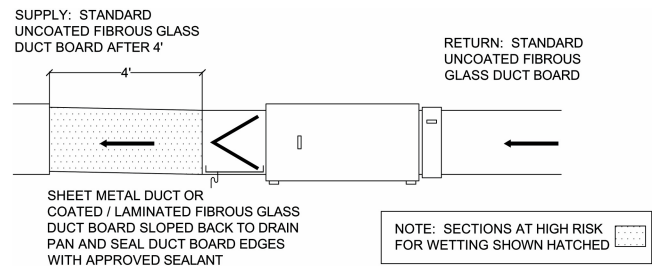

**Figure 4** Construction details for a horizontal supply system and a horizontal supply system with a horizontal return.

metal duct to prevent condensation potential. After four feet, the ductwork may be transitioned to standard uncoated fibrous glass duct board.

The other option is to use coated or laminated fibrous glass duct board adjacent to the coil for the first four feet. Again, this ductwork should be sloped back toward the furnace to prevent water from lying in the duct or running out through the duct system. All board edges must be sealed with a UL 181 approved closure system prior to fabrication to reduce the surface area of the exposed edge at seams. Standard uncoated fibrous glass duct board may be used after the first four feet of coated duct.

For a horizontal supply system with a horizontal return, again, standard uncoated fibrous glass duct board may be used in the return adjacent to the furnace fan, as shown in Figure 4.

**Application and Construction Detail: Downflow Condition.** The worst condition is in a downflow unit, where gravity carries the condensate in the direction of the airflow.

Any condensate that is carried over from the coil or leaks from the drain pan goes directly into the ductwork. For downflow furnaces, sheet metal should be used directly below the coil and then for four feet in the ductwork adjacent to the coil. After four feet, the ductwork may be transitioned to standard uncoated fibrous glass duct board. This application is demonstrated in Figure 5.

## CONCLUSION

This paper recommends the use of fibrous glass duct board in many locations. One main advantage of fibrous glass duct systems is that the duct has thermal insulation and does not require external insulation. Another advantage is acoustical performance; the material does not transmit vibration and attenuates mid-to-high-frequency equipment and airflow noises effectively. When following the SMACNA's (1992) recommendations for installation, ducts constructed of fibrous glass duct board will be airtight, durable, resistant to microbial growth, and quite effective at attenuation of duct-borne noise at high frequencies.

And a final recommendation—with the increasing availability of the coated and laminated duct boards and the clearly improved performance characteristics in cleaning and friction reduction, the choice should be easy to fabricate all future fibrous glass duct from the new generation of product.

## REFERENCES

- ASHRAE. 2001. *2001 ASHRAE Handbook—Fundamentals*. Atlanta: American Society of Heating, Refrigerating and Air-Conditioning Engineers, Inc.
- ICC. 2000. *International residential code for one- and two-family dwellings*. Falls Church, Va.: International Code Council.
- NAIMA. 1996. *Fibrous glass HVAC duct systems: Proven performance*. Pub. no. AH100, September. Alexandria, Va.: NAIMA.

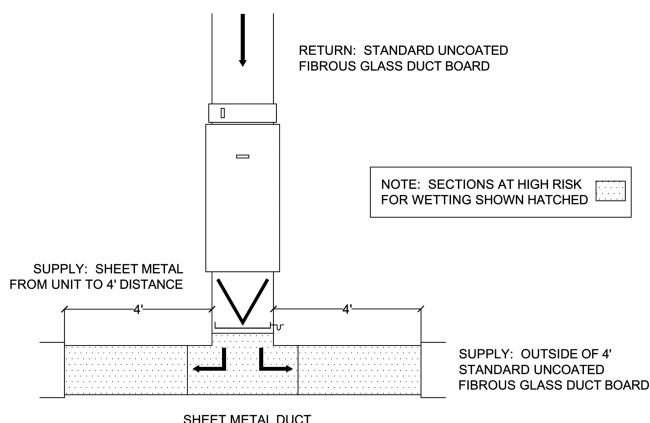

**Figure 5** Construction detail for downflow furnaces.

- NAIMA. 1997. *A guide to insulated air duct systems*. Pub. no. AH121, January. Alexandria, Va.: NAIMA.
- NAIMA. 1998. *Cleaning fibrous glass insulated air duct systems recommended practice*. Pub. no. AH122, March. Alexandria, Va.: NAIMA.
- NAIMA. 2002. *Fibrous glass duct construction standards*, 5th ed. Alexandria, Va.: NAIMA.
- SMACNA. 1992. *Fibrous glass duct construction standards*, 6th ed. Chantilly, Va.: Sheet Metal and Air Conditioning Contractors' National Association.
- Thomann, W.R., and J.J. Tulis. 1996. Fungal contamination of HVAC surfaces: The role of the dew point in microbial amplification. *IAQ 96, Path to Better Building Environments*, pp 25-29. Atlanta: American Society of Heating, Refrigerating and Air-Conditioning Engineers, Inc.