

30DSERIES

turbofan[®]

E32D5
(Digital Operation)

Installation and Operation Manual

turbofan
CONVECTION OVEN SYSTEMS



MANUFACTURED BY

Moffat Limited

Christchurch
New Zealand

INTERNATIONAL CONTACTS

AUSTRALIA

Moffat Pty Limited

E.Mail: vsales@moffat.com.au
Main Office: (tel) (03) 9518 3888
(fax) (03) 9518 3833
Service: (tel): 1800 622 216
Spares: (tel): 1800 337 963
Customer Service: (tel): 1800 335 315
(fax): 1800 350 281

CANADA

Serve Canada

Web: www.servecanada.com
E.Mail: info@servecanada.com
Sales: (tel): 800 551 8795 (Toll Free)
Service: (tel): 800 263 1455 (Toll Free)

NEW ZEALAND

Moffat Limited

Web: www.moffat.co.nz
E.Mail: sales@moffat.co.nz
Main Office: (tel): 0800 663328

UNITED KINGDOM

Blue Seal

Web: www.blue-seal.co.uk
E.Mail: sales@blue-seal.co.uk
Sales: (tel): 0121 327 5575
(fax): 0121 327 9711
Spares: (tel): 0121 322 6640
(fax): 0121 327 9201
Service: (tel): 0121 322 6644
(fax): 0121 327 6257

UNITED STATES

Moffat

Web: www.moffat.com
Sales: (tel): 800 551 8795 (Toll Free)
(tel): 336 661 1556
(fax): 336 661 9546
Service: (tel): 800 858 4477 (Toll Free)
(tel): 366 661 1556
(fax): 336 661 1660

REST OF WORLD

Moffat Limited

Web: www.moffat.co.nz
E.Mail: export@moffat.co.nz

The reproduction or copying of any part of this manual by any means whatsoever is strictly forbidden unless authorized previously in writing by the manufacturer.

In line with policy to continually develop and improve its products, Moffat Ltd. reserves the right to change the specifications and design without prior notice.

Contents List

E32 Turbofan Convection Oven.

Model Numbers Covered in this Manual

E32D5 - Turbofan Oven - 5 Tray Convection Oven.

Introduction	2
Safety Information	
Specifications	3
Installation	4
Installation Requirements	
Unpacking	
Location	
Clearances	
Stand Mounted Ovens	
Electrical Connection	
Water Connection	
Positioning and Levelling of Oven	
Initial Start-Up	
Commissioning	
Reversing the Oven Door	
Operation	8
Operation Guide	
Oven Control Panel	
Using the Oven - Manual Mode	
Cooking in Program Mode	
Setting the Oven Programs	
Oven Racks	
Operator Accessible Parameters	13
Setting the Operator Accessible Parameters	
Table of Operator Accessible Parameters	
Cleaning	14
Cleaning Guidelines	
Oven Cleaning	
Fault Finding	17
Electrical Schematics	18
Replacement Parts List	19

Introduction

Before using your new oven, please read this instruction manual carefully, pay particular attention to any information labelled '**WARNING**', '**CAUTION**', '**IMPORTANT**' or '**NOTE**' in this manual.



Warning

Indicates a hazardous situation which, if not avoided, will result in death or serious injury.



Caution

Indicates a hazardous situation which, if not avoided, will result in minor or moderate injury.

If you are unsure of any aspect of the installation, instructions or performance of your oven, contact your TURBOFAN dealer promptly. In many cases a phone call could answer your question.

Should you contact your TURBOFAN dealer on any matter concerning this oven, please have the information provided opposite, readily available.

This manual must be kept by the owner for future reference.

A record of the **Date of Purchase**, **Date of Installation** and **Serial Number of the oven** should be recorded in the area provided below.

The serial number of this oven can be found on the Technical Data Plate located on the front right hand side panel, see diagram in 'Installation Section'.

Model Number:

Serial Number:

Dealer:

Service Provider:

Date Purchased:

Date Installed:

Safety Information

For your safety, please pay attention to the following symbols marked on the appliance.

- Risk of electric shock.



No user serviceable parts inside.

Qualified service person access only.

Disconnect from power before servicing.

Specifications

E32D5

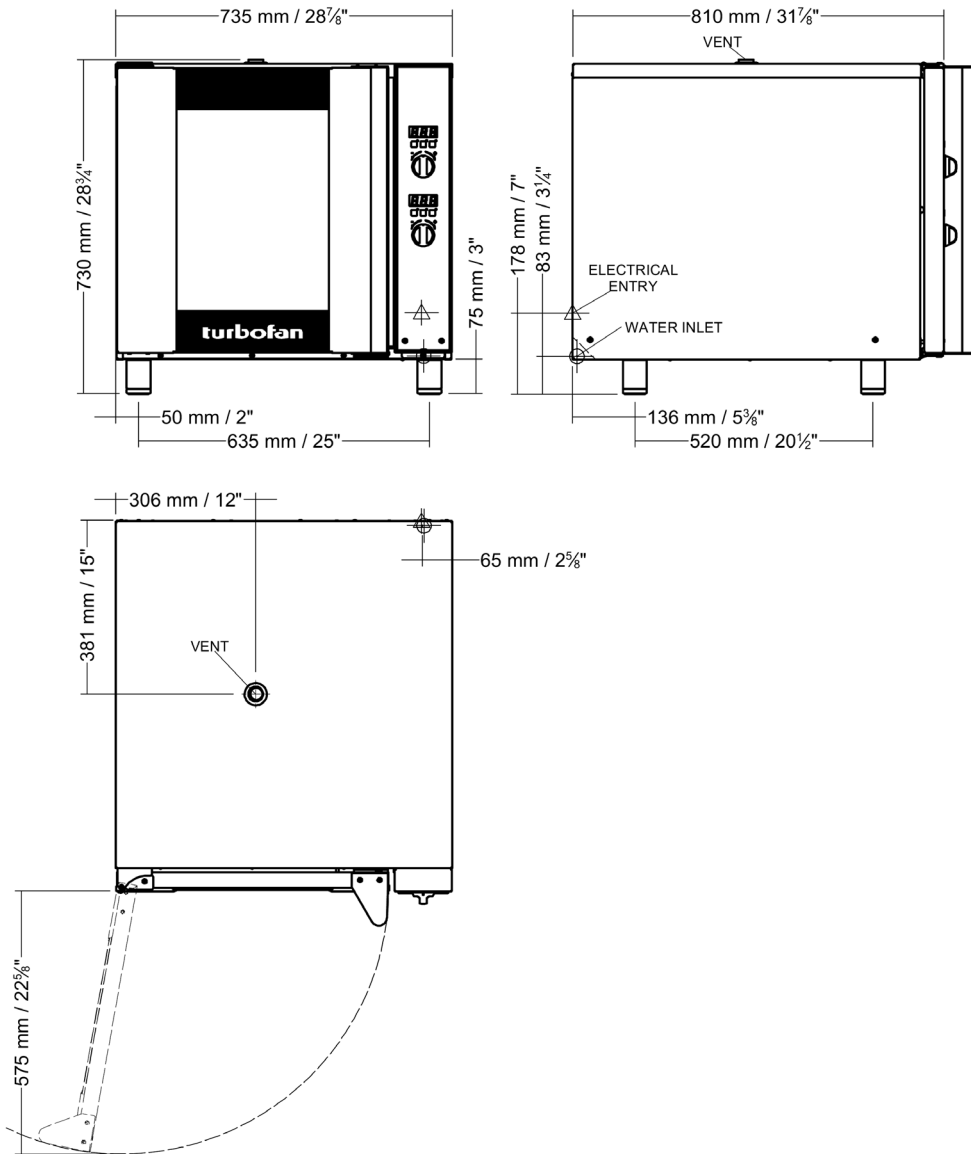

Oven Power Ratings		208V, 50/60Hz, 5.8 kW 220 - 240V, 50/60Hz, 6.5 kW
Oven Tray Details	Tray Capacity	5 x US Full Pan
	Tray Spacing	85 mm / 3 1/3"
Water Connection	Max Water Pressure	80 psi / 550 kPa.
	Connection Size	3/4" BSP

Installation

Installation Requirements

Important:

- Installation shall comply with local electrical, health and safety requirements.
- It is most important that this oven is installed correctly and that oven operation is correct before use.
- If you have any questions regarding the proper installation and / or operation of this oven, please contact your local Turbofan distributor.

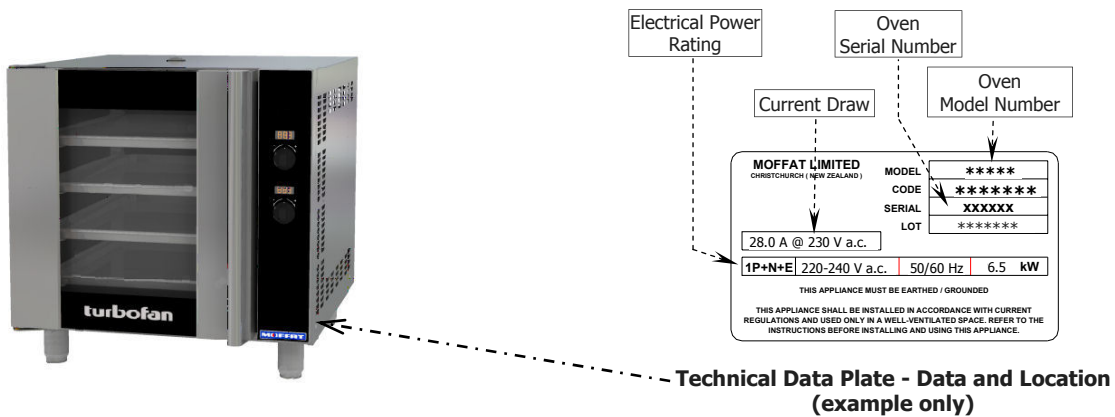

Unpacking

1. Remove all packaging and transit protection including all protective plastic coating from the exterior stainless steel panels.
2. Check the oven and supplied parts for damage. Report any damage immediately to the carrier and distributor.
3. Check that the following parts have been supplied with your oven:-
 - 4 x Leg Adjustable.
 - Water Connection Elbow.
4. Report any deficiencies to the distributor who supplied your oven.
5. Securely fit the 4 legs supplied with the oven.
6. Check that the available electrical supply is correct to that shown on the Technical Data Plate located on the front right hand side panel.

- Refer to 'Specifications' section, 'Oven Specifications Tables'.

Location

1. Position the oven in its approximate working position.
2. The unit should be positioned so that the control panel and oven shelves are easily reachable for loading and unloading.

Clearances

To ensure correct ventilation for the motor and controls, the following minimum installation clearances are to be adhered to:-

Top	200 mm / 8"
Rear	75 mm / 3"
Left-hand side	75 mm / 3"
Right-hand side	75 mm / 3"

NOTE: Fixed installations require at least 500 mm - 20" clearance at the right hand side of oven for service access.

Important:

The vent located on the top of the oven must NOT be obstructed.

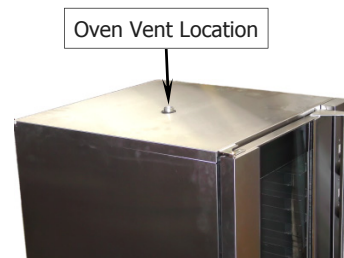

Stand Mounted Oven

For ovens that are to be mounted to a stand, the oven feet are used to level the oven on the stand. Refer to the instructions supplied with separately ordered stands for mounting details.

Installation

Electrical Connection



Warning

This oven must be earthed / grounded.

Each oven should be connected to an adequately protected power supply with an appropriate three wire power cord. An isolation switch must be mounted adjacent to, but not behind the oven and must be readily accessible to the operator. This switch must be clearly marked and readily accessible in case of fire.

Check the electricity supply is correct to as shown on the Technical Data Plate on the front right hand corner of the oven side panel.

NOTE: All electrical connections must only be carried out by a suitably qualified person.

1. Remove oven right hand side panel.
2. Bring the supply cable up through the grommet at the back of oven and through the compression gland on the electrical switchgear panel.
3. Connect the mains supply to the appropriately marked terminals on the terminal block.

Water Connection - Optional (not required for main oven operation)

1. If the manual addition of water into the oven for humidification or steaming effect on baked product is required, the unit's water connection can be used.
2. A cold water supply should be fitted to the water inlet ($\frac{3}{4}$ " BSP hose connection) which is located on the rear of the right hand side of the oven.
3. Alternately, a connection elbow and sealing washer is supplied with this unit for direct connection of a $\frac{1}{2}$ " ID hose, and is recommended for easy installation and service.
4. Connect to the water supply.

- Max Inlet Pressure 80psi / 550kPa.

5. Turn 'On' the water supply and check for leaks.

Positioning and Levelling of Oven

1. Correctly locate the oven into its final operating position and using a spirit level, adjust the oven feet so that the oven is level and at the correct height.

Initial Start-Up

Before using the new oven;

1. For first time use of the oven, operate the oven for about 1 hour at 200°C / 400°F to remove any fumes or odours which may be present.
2. Please refer to the Operation Section of this manual for details on how to correctly operate and shutdown the oven.

Commissioning

Before leaving the new installation;

Check the oven functions in accordance with the operating instructions specified in the 'Operation' section of this manual.

Ensure that the operator has been instructed in the areas of correct operation and shutdown procedure for the appliance.

NOTE: If for some reason it is not possible to get the appliance to operate correctly, turn off the power supply at the mains supply and contact the supplier of this appliance.

Installation

Reversing the Oven Door

NOTE: This operation should only be carried out by a suitably competent person.

Remove the Oven Door Inner Glass.

1. Open the oven door and open the door inner glass.
2. Remove the screw securing the inner glass retaining clip and remove the clip.
3. Lift up the inner glass and remove, ensuring that the pivot spacer is removed from the lower inner glass pivot and retained.

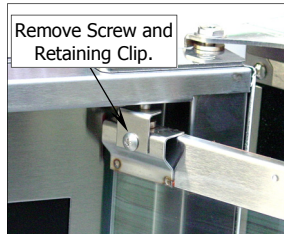

4. Remove the black plastic plugs from the top and bottom of the door and fit to the holes where the inner glass pivots were removed from.

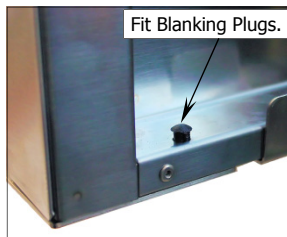

Remove the Oven Door.

5. Remove the door roller catch and blanking plate from the inside of the door and swap these over.

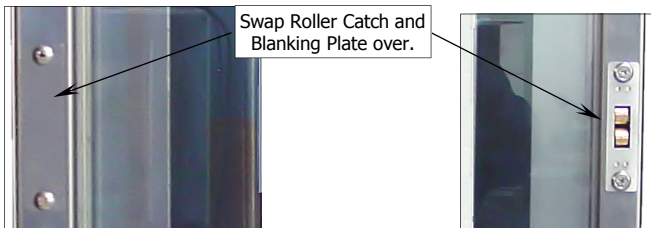

6. Whilst supporting the door, unscrew and remove the top door pivot bolt from the top door hinge assembly.
7. Remove the door and lay on a flat surface or workbench.

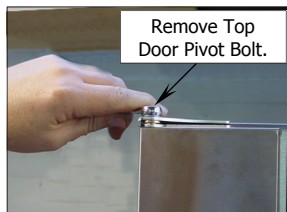

8. Unscrew the screws securing the door handle and remove the door handle.



9. Remove the top door hinge and fit to the bottom opposite corner of the door.
10. Remove the bottom door hinge and fit to the top opposite corner of the door.

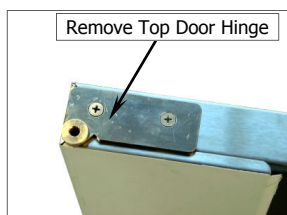

11. Remove the inner glass latching studs and fit to opposite side of door using Loctite 243 to secure.



12. Turn the door handle over and fit to the other end of the door where the hinges were removed from. Ensure flat of handle is to the outside.

Remove the Upper and Lower Door Hinges and Door Catch.

13. Remove the bottom door pivot bolt and spacers and fit the pivot bolt to the top door hinge assembly (as this will be swapped over and fitted to the bottom of the other side of the oven).

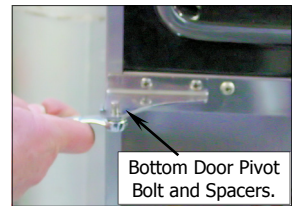

14. Remove the 4 blanking screws from the front of the oven.

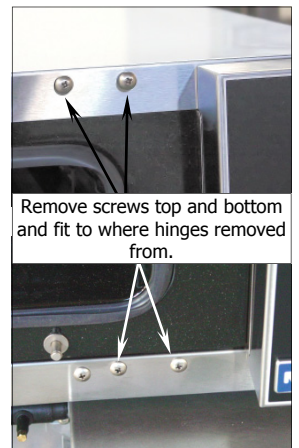

15. Remove the Hinge Plate from the top of the oven and fit diagonally opposite, to the lower corner.



16. Remove the Hinge Plate from the bottom of the oven and fit diagonally opposite, to the upper corner.

17. Fit the screws removed at Item 14 above to where the hinges were fitted.



Installation

16. Remove the Blanking Screw and Door Catch from the front of the oven and swap around.

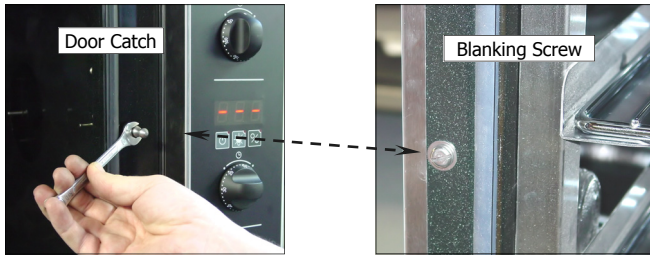

17. Fit the door spacers removed at Item 13 opposite to the lower hinge pivot bolt.

Oven Door Re-Fitting

Fit the Door.

1. Refit the oven door by locating the bottom of the door onto the bottom hinge plate pivot bolt and spacers.
2. Fit the top of the door into the top hinge plate and secure with the top pivot bolt.

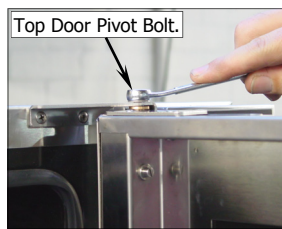

Fit Inner Glass to Door.

NOTE: It is important to ensure that the inner glass is fitted correctly and that the glass pivots at the hinge end of the door and not the handle end.

3. Fit the pivot spacer removed at Item 3 on the previous page, to the lower inner glass pivot and locate the inner glass lower pivot into position on the inside of the door.
4. Locate the top pivot of the inner glass into the top of the door and secure in position with the inner glass retaining clip.

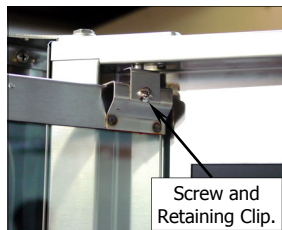

5. Lift the inner glass up onto the locking catch to lock into position.



Adjust the Door for Correct Alignment.

Check the operation of the door. Ensure that the door roller catch correctly retains the door in the closed position.

To adjust, slightly loosen the screws securing the roller catch and close the door. The roller catch will centralise itself. Open the door and tighten the roller catch securing screws.

Operation

Operation Guide



Warning

Some parts of this oven will become **VERY HOT** during use and could cause burns if touched.



Warning

Take care when opening the oven door during baking. Let hot air and steam escape before removing or replacing food as the steam produced can cause steam burns.

- Turbofan Ovens have been designed to provide simple operation.
- This oven is intended for use in a commercial kitchen and must only be put to the use for which it was intended, i.e. cooking food product. To use this oven correctly please read the following sections carefully:-

Oven Control Panel

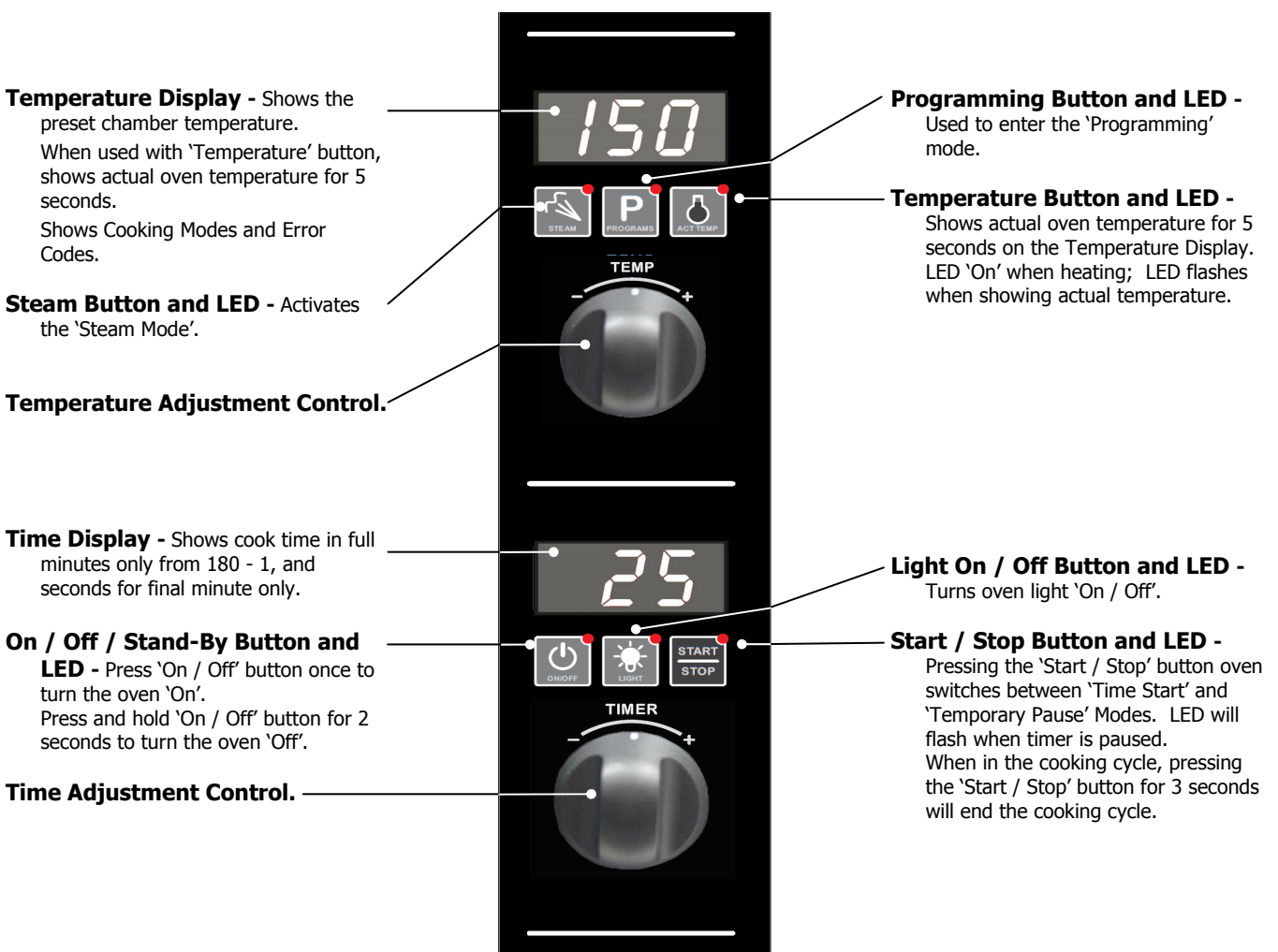

Starting the Oven

1. Turn 'On' electrical power to the oven. The controller will carry out a self check of the LED's.
2. Press the 'On/Off' Button.
3. The Heating Indicator will illuminate.

Oven Shut-Down

1. To turn 'Off' the oven, press and hold the 'On/Off' button for 3 seconds, the oven controller will go to 'Stand-By' mode.

Operation

Using the Oven - Manual Mode

1. TURN 'ON'.

Press 'On-Off' button.



Temperature Display.

Temperature Display will show actual temperature.

2. SET TEMPERATURE.

- + to increase the temperature.
- to decrease the temperature.

Time Display.

Time Display will show actual time set.

3. SET TIME.

- + to increase the time.
- to decrease the time.

4. START TIMER.

Press 'Start / Stop' button to start timer operation.

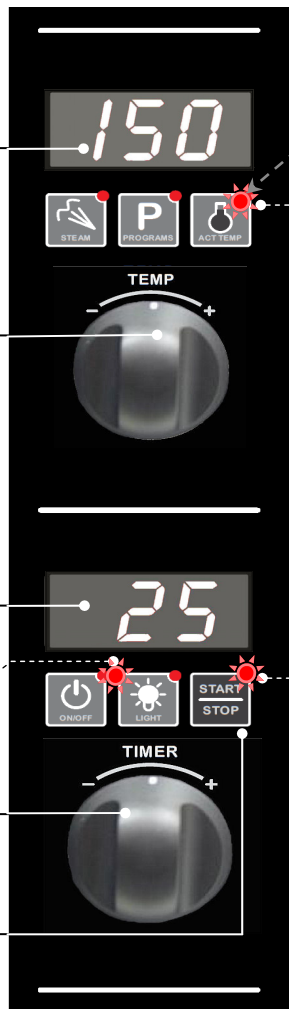

To check actual oven temperature during preheat or cooking, press 'Temperature' button. Actual temperature will display briefly on 'Temperature Display' before the display reverts to the pre-set temperature.

Heating 'On' Indicator

At any time during cooking, time and temperature can be adjusted by using the 'Time' / 'Temperature' controls.

Timer 'On' Indicator

This oven can be used without using the 'Timer', as it is purely a timer and does not control the baking operation of the oven.

If the 'Timer' is set to the 'Infinity' setting **Inf**, the timer will count elapsed time to a maximum of 999 minutes.

Opening the oven door during a cooking cycle will pause the cooking time. To continue cooking, close the oven door.

- Press any button, to cancel the 'Alarm'.



- Press 'Steam' button, to select the Steam mode.



- Press 'Act Temp' button, to check 'Actual' temperature of oven at any time during cooking.



- Press 'Light' button, to turn 'On' oven light. (refer - 'Operator Accessible Parameters').



- Press 'Program' button, to program the Oven refer to the 'Installation and Operation Manual'.



- Press and hold 'On / Off' button, for 3 seconds to turn 'Off' the Oven.

Steam; - Steam function can be selected at any time during the Manual Mode by pressing the 'Steam' button. Steam will be injected for the pre-set time and the 'Steam' LED will illuminate.

Operation

Cooking in Program Mode

1. TURN 'ON'.

Press 'On-Off' button.



Press 'Programs' button.



Temperature Display.

Temperature Display will show program selected.

2. SELECT A PROGRAM.

+ to scroll forward through programs.
- to scroll backward through programs.

Time Display.

Time Display will show 'Pre-Heating'.
Program cannot be started until pre-heating is completed.

Load Oven.

'Time' display will show 'Ready'.

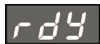

3. START PROGRAM.

Press 'Start / Stop' button to start cooking program.



Program Mode Indicator

Heating 'On' Indicator

To check actual oven temperature during preheat or cooking, press 'Temperature' button. Actual temperature will display briefly on 'Temperature Display' before the display reverts to the pre-set temperature.

When cooking in 'Program' mode, the oven light will remain 'On' until cooking is completed.

Opening the oven door during a cooking cycle will pause the cooking time. To continue cooking, close the oven door.

- Press any button, to cancel the 'Alarm'.



- Press 'Steam' button, to select the Steam mode.



- Press 'Act Temp' button, to check 'Actual' temperature of oven at any time during cooking.



- Press 'Program' button, to program the Oven refer to 'Setting the Oven Programs' overleaf.



- Press and hold 'On / Off' button, for 3 seconds to turn 'Off' the Oven.

Steam; - Steam function can be selected at any time during the Program Mode by pressing the 'Steam' button. Steam will be injected for the pre-set time and the 'Steam' LED will illuminate.

Refer to 'Operator Accessible Parameters' for steam options.

Operation

Setting the Oven Programs

Oven can be pre-programmed with up to 20 Program's. When you receive your oven, the controller is not programmed. To set programs, carry out the following for each program required:-

1. ENTER PROGRAMMING MODE.

Press '**Programs**' button to enter 'Programming' mode.



2. SELECT PROGRAM REQUIRED.

Rotate '**Temperature Control**' to program required.

Temperature Display will show program selected.

Press and hold '**Temperature**' button until '**Time**' and '**Temperature**' displays and '**Temperature**' LED flashes.



Change time and temperature parameters.

3. ENTER COOK TEMPERATURE.

Rotate '**Temperature Control**' to set cook temperature.

- + to increase the temperature.
- to decrease the temperature.

'**Temperature**' Display will show temperature selected.



4. ENTER COOK TIME.

Rotate '**Timer Control**' to set cook time.

- + to increase the time.
- to decrease the time.

'**Time**' Display will show time selected.



'**Time**' and '**Temperature**' displays and '**Temperature**' LED flash.



Press '**Temperature**' button to confirm '**Time**' and '**Temperature**' settings.

5. SET STEAM OPTION.

Hold '**Steam**' button pressed until '**Steam**' LED flashes and present setting displays in '**Temperature**' display.



Rotate '**Temperature Control**' to set steam time required.

- + to increase steam time.
- to decrease steam time.

Press '**Steam**' button to confirm '**Steam**' settings.



Operation

Oven Racks

The oven is supplied with four general purpose oven racks.

- **Self Supporting:** When fitted, the oven racks are self supporting and will not drop or angle down when the racks are withdrawn during operation, when loading and unloading products onto racks or when attending to the product being cooked during it's cook cycle.

NOTE: Ensure that the racks are correctly fitted to the oven with the raised part of the rack to the rear of the oven and the hooks on the underside of the rack engaged below the rack runner.

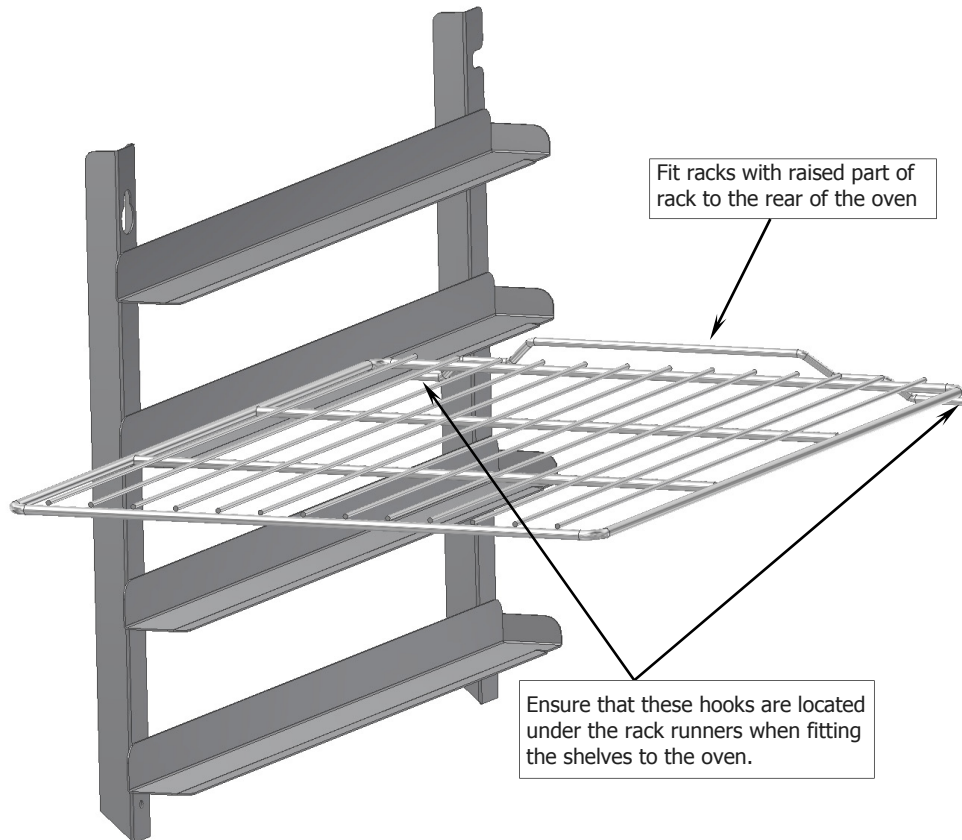

Operator Accessible Parameters

Setting the Operator Accessible Parameters

1. ENTER THE OPERATOR PARAMETER MODE.

Press 'Steam' and 'Start / Stop' buttons together.

'Temperature' Display will show 'PAS'.

The 'Time' Display will flash.



2. SET PASSWORD.

Rotate 'Timer Control' to set password;
(123) (Operator Password).

Press 'Light On / Off' button to confirm password.

'Temperature' Display will show one of Parameter Codes.

'Time' Display will show value of the parameter.



3. SETTING THE PARAMETERS.

Rotate 'Timer Control' to parameter required.

Press 'Light' button to confirm parameter. 'Time' display will flash.

While 'Time' display is flashing, rotate 'Timer Control' to select value required.

Press 'Light' button to confirm value. 'Time' display will stop flashing.



4. EXITING THE PARAMETER MODE.

Press 'On-Off' button, to return to 'Stand-By' mode.



Table of Operator Accessible Parameters

Parameter Number	Description	Default Setting
	Turn -On Pre-Heating temperature - (60 - 260°C).	150
	Light Auto 'Off' Setting Time - 0 = 'On/Off'. 1 = 1 minute auto 'Off'. 2 = 2 minutes auto 'Off', etc.	1
	Steam Injection setting time - 0 = Steam will be emitted for as long as 'Steam' button is pressed. 1 = Steam will be emitted for 1 second. 2 = Steam will be emitted for 2 seconds, etc.	1
	Buzzer Volume - Can be adjusted from '0' to '10'.	5
	Program Pre-Heating Condition - (Can be adjusted from 0 to 30 degrees above pre-heat temperature).	10

Cleaning

Cleaning Guidelines



Caution

Always turn off electrical power at the mains supply before commencing cleaning.

This oven is not water proof. Do not use water jet spray to clean interior or exterior of the appliance.

To achieve the best results, cleaning must be regular and thorough. If any small faults occur, have them looked at promptly. Don't wait until they cause a complete breakdown.

NOTE:

- Carefully read and follow the safety instructions on the label of the cleaning product to be used.
- **DO NOT** use harsh abrasive scouring pads or abrasive detergents as they could damage the oven.
- Ensure that any detergent or cleaning material has been completely removed after each cleaning.

To keep your oven clean and operating at peak efficiency, follow the procedures shown below:-

Oven Cleaning

NOTE:

- If oven usage is very high, the cleaning procedure should be carried out on a more frequent basis.
- Allow the oven interior to cool to approx 50°C / 120°F before commencing cleaning.

Stainless Steel Surfaces

- Thoroughly clean the exterior surfaces of the oven with, a damp cloth moistened with a mild detergent solution, or a soft bristled brush.
- Baked on deposits or discolouration may require a good quality stainless steel cleaner. Always apply cleaner when the oven is cold and rub in the direction of the grain.

Side Racks Removal

Right Rack / Fan Baffle

- Undo and remove the rack securing screw securing the front of the RH side rack. The fan baffle is an integral part of the RH Side Rack.

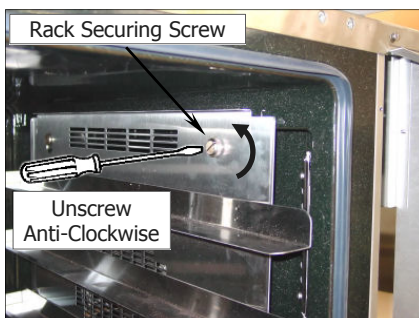

- Lift up and unhook the rear of the rack from the locating peg at the rear of the oven.

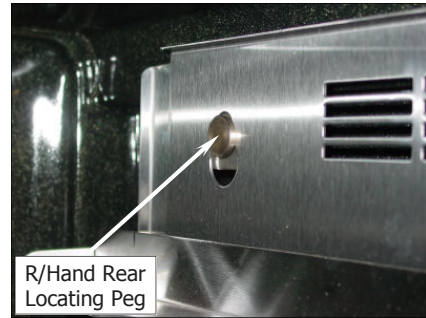

- Tilt the top of the rack inwards and lift the rack off the lower mounting brackets.

Left Rack

- Lift the LH rack off the front locating peg.

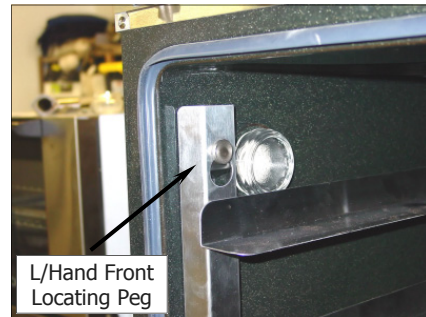

- Pull the rack forward out of the oven to disengage the rear of the rack from the rear location peg and remove the rack from the oven.



- Clean the racks with a mild anti bacterial detergent and hot water, using a soft bristled brush.
- Dry the racks thoroughly with a dry cloth.

Cleaning

Side Racks Re-Fitting

Right Rack

- Align the bottom of the rack with the 2 brackets in the bottom RH side of the oven.

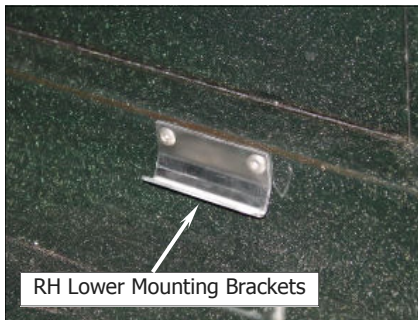

- Tilt the rack upwards and hook the top rear of the rack onto the locating peg in the top rear of the oven.

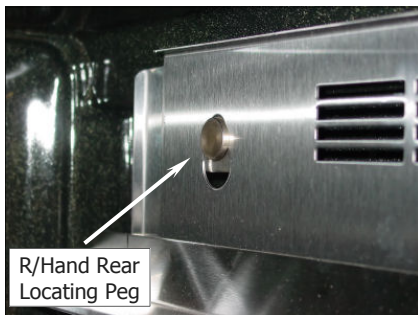

- Fit and tighten the rack securing screw to secure the front of the RH rack.

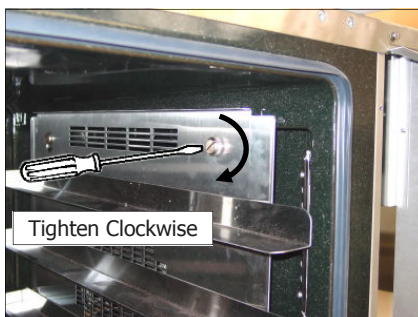

Left Rack

- Locate the top rear of the rack onto the locating peg at the top rear LH side of the oven.



- Locate the top front of the rack over the locating peg at the top front LH side of the oven.

Lamp Glass

- Remove the LH side rack as shown previously.
- Unscrew (anti-clockwise) and remove the lamp glass from the oven.

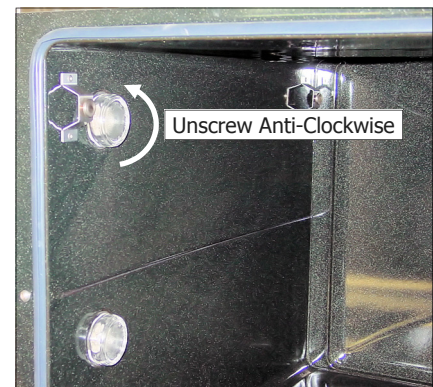
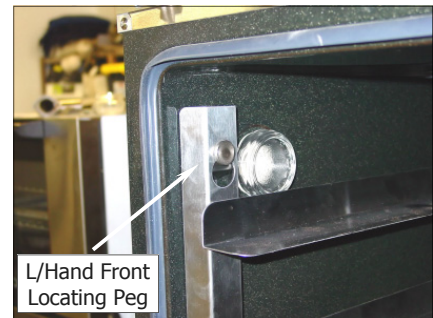

- Remove seal fitted between lamp glass and holder.



- Wash the lamp glass and seal with a soft sponge using warm water and a detergent solution. Rinse with clean, warm water and dry off.
- Dry the lamp glass thoroughly with a dry cloth.

NOTE: The lamp glass seal must be fitted with the flat face of the seal towards the lamp glass.

- Refit the lamp glass, screw the glass in clockwise to secure. **Do not over tighten lamp glass.**
- Refit the LH side rack as shown previously.

Cleaning

Door Seal

- a. To remove the door seal, pull the 1 piece seal forward until it pulls out of the location groove around the oven. **Note the way the seal is fitted to the oven, with the lip facing inwards.**



- b. Check the door seal for wear and damage and replace as required.
- c. Wash the door seal in a sink, taking care not to cut or damage the seal.
- d. Dry the door seal thoroughly.
- e. Refit the door seal with lip facing into centre of the oven.



- f. Press the door seal into the locating groove in the front face of the oven until the seal is properly located all around the oven.

Oven Interior

- **Allow the oven interior to cool to approx 50°C / 120°F before commencing cleaning.**
 - a. Remove the oven racks as shown previously.
 - b. Clean any build up of grease from the oven interior, using a soft bristled brush with a solution of hot water and a mild anti bacterial detergent.
 - c. Dry the oven thoroughly with a soft dry cloth.
 - d. Clean the oven regularly with a good quality oven cleaner.

Door Glass Cleaning

- **Ensure that the oven door is cool before cleaning the oven door glass.**

- a. Open the oven door.
- b. Lift up the bottom of the inner glass at the centre of the door to unlock from the inner glass retaining catches and swing the glass inwards towards the oven.

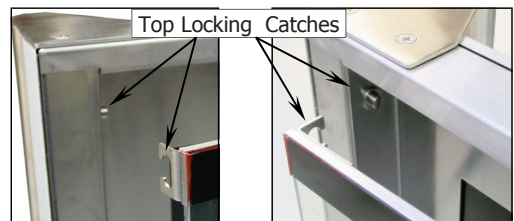
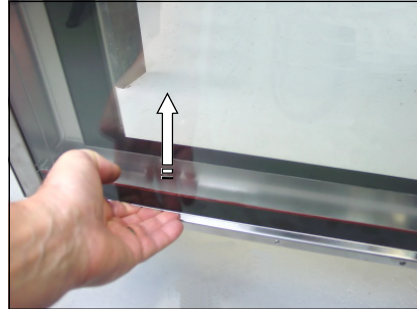

- c. Clean both sides of the inner glass and the inner side of the outer door glass with a conventional glass cleaner.
- d. Dry the oven door thoroughly with a soft dry cloth.
- e. Swing the inner glass back towards the outer door.
- f. Whilst holding the outer door, lift the inner glass back onto the locking catches until the inner glass is securely held.

Fault Finding

This section provides a reference to the more common problems that may occur during the operation of your oven. This fault finding guide is intended to help you correct and accurately diagnose problems with your oven.

You may encounter a problem not covered in this section, please contact your service provider who will require the following information:-

When fault finding a problem, always use a process of elimination starting with the simplest solution and working through to the most complex. Never overlook the obvious.

- **The Model and Serial Number of the oven, can be found on the Technical Data Plate located on the front right hand side panel of the oven.**

Fault	Possible Causes	Remedy
Oven does not operate.	Mains isolating switch, circuit breaker or fuses are 'Off' at the power board.	Turn 'On'.
	Overtemp tripped (No lights, no power light).	Call for service.
	Overtemp faulty.	Call for service.
	Digital Controller faulty	Call for service.
Oven Controller operates but No Heat in Oven.	Element faulty.	Call for service.
	Digital Controller faulty	Refer to 'Digital Controller Fault Codes'. Call for service.
	Door not closed fully.	Close door. (Refer 'Door does not close fully').
	Door Switch faulty.	Call for service.
Oven heats up but fan does not operate.	Heating Relay faulty.	Call for service.
	Fan motor faulty.	Call for service.
	Fan or fan motor obstructed.	Call for service.
Oven does not Steam.	Injector Nozzle blocked.	Call for service.
	Water Solenoid faulty.	Call for service.
	Controller faulty.	Call for service.
Door does not close fully.	Tray in way of door.	Correctly position tray in rack.
	Door mis-aligned.	Re-align door.
	Door seal obstruction.	Correctly install door seal. (Refer to the 'Cleaning' Section).
Oven light not illuminating.	Blown bulb.	Replace bulb.
	Blown Fuse	Call for service.
Uneven cooking.	Too high a temperature selected.	Select a lower temperature.
	Oven or racks not level.	Check oven racks and level.
	Insufficient air space around trays or baking tins.	Ensure oven racks are spaced to allow air flow around baking on all shelves.
	Oven overloaded with too much product.	Re-load oven.
	Opening oven door un-necessarily.	Ensure oven door remains closed during the baking process.
	Oven door seal damaged or faulty.	Check seals and replace if damaged.
	Oven vent restricted.	Ensure oven vent not blocked or shrouded.
'Err 001' on display.	Probe error.	Call for service.
'Err 003' on display.	Digital input error.	Call for service.

Electrical Schematics

Electrical Schematic E32D5 Turbofan Oven

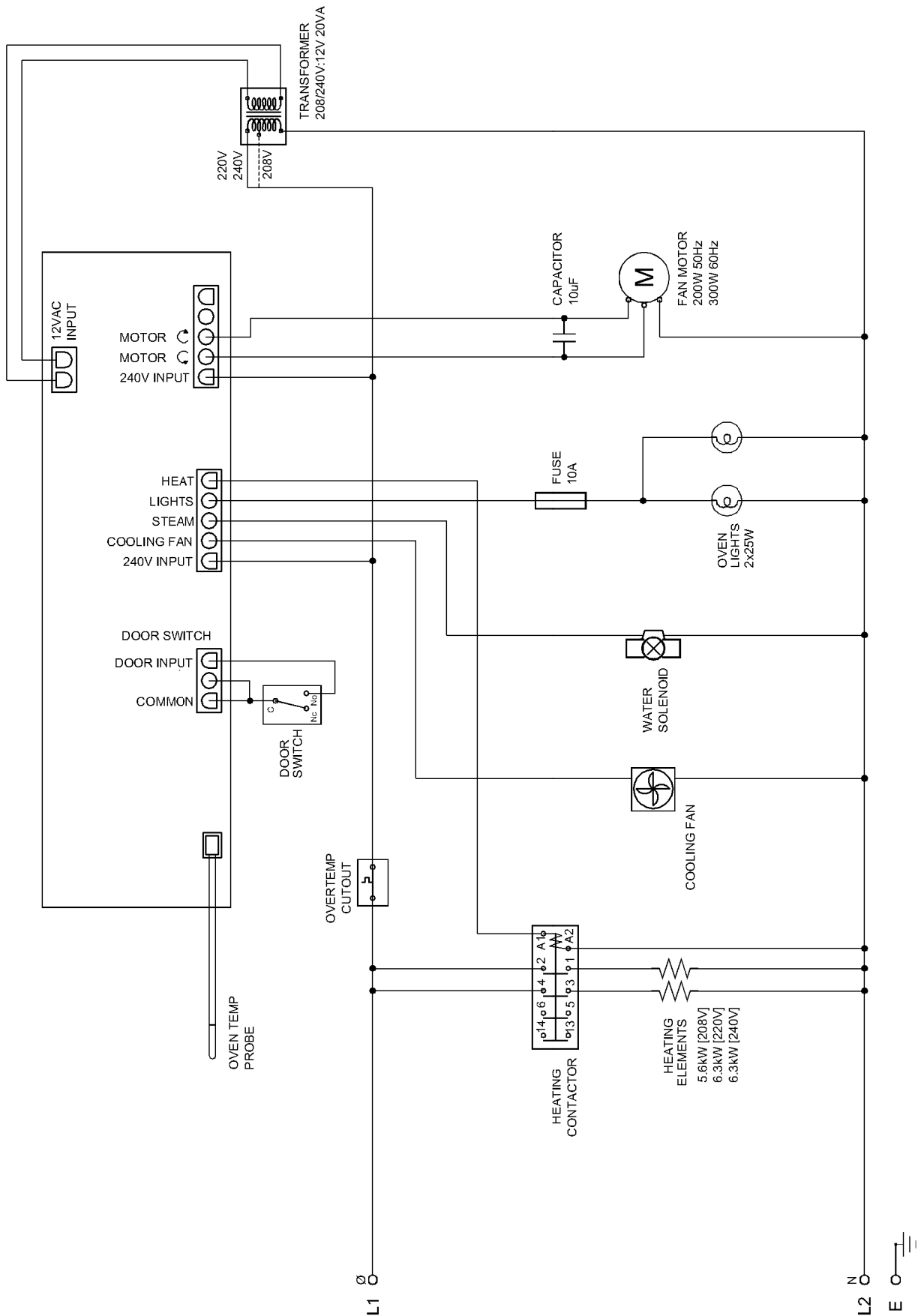

Replacement Parts List

Important:

**Only genuine authorized replacement parts should be used for the servicing and repair of this oven. The instructions supplied with the parts should be followed when replacing components.
For further information and servicing instructions, contact your nearest authorized service provider or Turbofan Dealer.**

When ordering replacement parts, please quote the part number and the description as listed below. If the part required is not listed below, request the part by description and quote model number and serial number which is shown on the Technical Data Plate.

Item	Description
234632	Digital Control Board Kit E32D
234429	Transformer 208 / 240V x 12V AC SEC, 20VA
234460	Cooling Fan 208 - 230V, 50 / 60Hz
234450	Encoder
234434	Temperature Probe 20 mm PT1000 1 mtr
231738	Contactora 25A, 3P + 1NO, 230V, 50 / 60Hz
234105	Oven Element, 6300W, 208 - 220V
234106	Oven Element, 6300W, 230 - 240V
234468	Fan Motor, 200W, 220 - 240V, 50Hz
234595	Fan Motor, 200W, 220 - 240V, 60Hz
025400	Overtemp, 360°C - 680°F
024802	Door Microswitch E32
234252	Capacitor 10uF
020851	Water Solenoid 90° Outlet, 240V
234447	Knob Indexed
233115	Oven Lamp Lens
231814	Lamp Bulb G9 25W, Halogen, 230V
234802	Fuse Holder
TBA	Fuse
234580	Door Roller Catch
234582	Door Catch Strike
234626	Door Hinge Top
234627	Door Hinge Bottom
232666	Door Seal - E32
232379	Foot Adjustable (73 - 80 mm)
234658	Side Rack LH, 5 tray,
234659	Side Rack RH, 5 tray,
233649	Oven Rack E32D
233552	Rack Securing Screw

