

Operating and Installation Instructions Gas cooktop

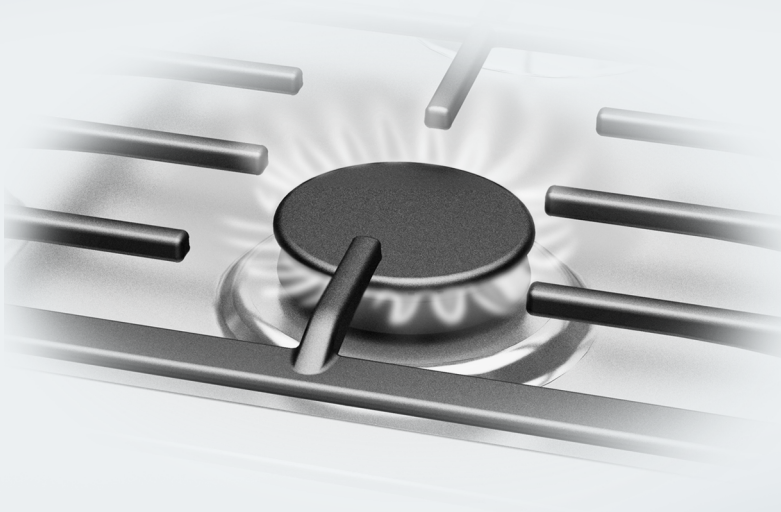

To prevent accidents and machine damage, read the Operating Manual **before** installation or use.

WARNING:

If the information in this manual is not followed exactly, a fire or explosion may result causing property damage, personal injury or death.

- Do not store or use gasoline or other flammable vapors and liquids in the vicinity of this or any other appliance.
- **WHAT TO DO IF YOU SMELL GAS**
 - Do not try to light any appliance.
 - Do not touch any electrical switch.
 - Do not use any phone in your building.
 - Immediately call your gas supplier from a neighbor's phone. Follow the gas supplier's instructions.
 - If you cannot reach your gas supplier, call the fire department.
- Installation and service must be performed by a qualified installer, service agency or the gas supplier.
(In Massachusetts installation must be performed by a licensed plumber / gas fitter.)
- Note to the installer:
Please leave this instruction book with the consumer for the local electrical / gas inspector's use.



IMPORTANT SAFETY INSTRUCTIONS	4
Description of the appliance	8
Before the first use	11
Using the cooktop	12
Control knobs.....	12
Turning on.....	13
Regulating.....	14
Turning off.....	14
Cookware	15
Energy saving tips	16
Safety feature	17
Cleaning and care	18
Frequently asked questions	21
Technical Service	23
IMPORTANT INSTALLATION SAFETY INSTRUCTIONS	26
Installation dimensions	29
Installation	30
Securing the appliance	33
After installation.....	33
Electrical connection	34
Wiring diagram.....	35
Gas connection	36
Gas pressure regulator.....	37
Conversion to another type of gas	38
Burner performance	39
Help protect our environment	40

IMPORTANT SAFETY INSTRUCTIONS

WARNING - When using your gas appliance follow basic precautions, including the following:

This gas cooktop conforms to all uniform safety codes and regulations.

Read all instructions before installation or use to prevent injury and appliance damage.

These instructions contain important information on installation, safety, use and maintenance of this appliance. They will help you avoid injury and damage to the appliance.

Keep these operating instructions in a safe place and pass them on to any future user.

SAVE THESE INSTRUCTIONS

Correct usage

- ▶ This appliance is intended for use in domestic households and in similar working and residential environments.
- ▶ Only use this gas cooktop for residential purposes such as cooking and keeping food warm. Other uses are not permitted and can be dangerous.
- ▶ This appliance is not intended for outdoor use.
- ▶ Persons who lack physical, sensory or mental abilities, or experience with the appliance should not use it without supervision or instruction by a responsible person.

Children

- ▶ Children should not be left unattended in an area where the appliance is in use. Never allow children to sit or stand on any part of the appliance.
- Caution:** Do not store items of interest to children in cabinets above the appliance. Children climbing on the appliance to reach these items could be injured.
- ▶ The appliance is hot during use and remains so for some time after being switched off. Keep children away from the appliance.
- ▶ Keep all pots and pans out of the reach of children. Danger of burning or scalding.
- ▶ Ensure that any packing material, is disposed of safely and kept out of the reach of children. Danger of suffocation!

IMPORTANT SAFETY INSTRUCTIONS

Technical safety

► Installation, repair and maintenance work should be performed by a Miele authorized service technician in accordance with local building and safety codes. Work by unqualified persons could be dangerous and may void the warranty.

► Before installing the cooktop, check for externally visible damage. **Do not** operate a damaged appliance. A damaged gas cooktop is a hazard.

► Be certain your appliance is properly installed and grounded by a qualified technician.

► To guarantee the electrical safety of this appliance, continuity must exist between the appliance and an effective grounding system. It is imperative that this basic safety requirement be met. If there is any doubt, have the electrical system of the house checked by a qualified electrician.

► Before installation, make sure that the voltage and frequency listed on the rating label correspond with the household electrical supply. This data must correspond to prevent injury and appliance damage. Consult a qualified electrician if in doubt.

► Do not operate the appliance until it has been properly installed in the countertop.

► Under no circumstance open the outer casing of the appliance. This is a safety hazard and may damage the appliance.

► Before servicing, turn off the gas valve and disconnect the power supply by either removing the fuse, unplugging the unit or manually "tripping" the circuit breaker.

► While the appliance is under warranty repairs should only be performed by a Miele authorized service technician. Otherwise the warranty is void.

► Defective components should be replaced by Miele original spare parts only. Only with these parts can the manufacturer guarantee the safety of the appliance.

► The appliance is not designed for use with an external timer or a remote control system.

► Do not operate any appliance with a damaged cord or plug, or if the appliance has been damaged in any manner. Contact Miele's Technical Service Department.

► Do not use an extension cord to connect this appliance to electricity. Extension cords do not guarantee the required safety of the appliance.

► In the event of damage or defect, turn off the appliance immediately. Turn off the gas shut off valve and disconnect completely from the electrical supply. Contact the Miele Technical Service Department.

Do not use the appliance until it has been repaired.

Ensure power is not supplied to the appliance while repair work is carried out.

IMPORTANT SAFETY INSTRUCTIONS

Safety

▶ The appliance is hot during use and remains so for some time after being switched off. Be careful not to touch the appliance if it may still be hot.

▶ Do not heat empty pots or pans. This may cause damage to the cookware and the surrounding area. Danger of fire.

▶ Do not leave the cooktop unattended while in use. Boil-overs cause smoking, and greasy spill-overs may ignite.

▶ Do not use water on grease fires. Smother any fire or flame using a lid, or use a dry chemical or foam-type extinguisher.

 **WARNING** - NEVER use this appliance as a space heater to heat or warm the room. Doing so may result in carbon monoxide poisoning and overheating.

▶ Protect your hands with oven mitts or potholders when using the appliance. Use only dry, heat resistant potholders. Moist or damp potholders used on hot surfaces can result in steam burns. Do not let the potholder touch the hot heating elements. Do not use towels or other bulky items near the appliance.

▶ Do not flambé under an exhaust hood. Flames could be drawn up into the hood by the suction or the grease filters may ignite.

▶ Spills containing salt or sugar should be removed immediately.

▶ Do not store items on the appliance when not in use. Items could melt or catch fire from residual heat or if the appliance is turned on inadvertently. Always switch the burner(s) off after use.

▶ Do not store aerosols, combustibles or any other easily flammable materials underneath or adjacent to the appliance.

▶ Do not use plastic or aluminium foil on any part of the cooktop. It melts at high temperatures. Fire hazard.

▶ Do not heat unopened containers. Built-up pressure may cause the container to burst and result in injury.

▶ Make sure all components of the gas burner are assembled correctly before using the cooktop.

▶ Do not use pans that extend past the burner grate. Using larger pans may cause the flames to spread out and damage the surrounding countertop or other countertop appliances.

▶ For safety and stability, do not use pans with a bottom diameter smaller than the burner grate.

IMPORTANT SAFETY INSTRUCTIONS

- ▶ Only certain types of glass, ceramic or other glazed cookware are suitable for use on a cooktop without breaking due to the sudden temperature change.
- ▶ Do not use containers made of plastic or aluminium. They may melt at high temperatures.
- ▶ The burner grates supplied with the appliance must always be used. Never place a pan on the burner by itself.
- ▶ Do not let cooking grease or other flammable materials accumulate on the appliance. Fire Hazard.
- ▶ Place the grates on vertically to prevent any scratches.
- ▶ The use of a gas cooktop leads to the formation of heat, moisture and combustion products in the room where the appliance is installed. Ensure proper attention is paid to the ventilation of the installation area: windows kept open or a ventilation hood installed and running.
- ▶ When using a portable appliance near the cooktop, make sure that its power cord does not come in contact with the cooktop.
- ▶ If there is a drawer directly underneath the appliance without a wooden base in between, ensure that no aerosols, combustible liquids or other easily flammable materials are kept in it. If cutlery inserts are to be placed in the drawer, they must be made of a heat-resistant material.
- ▶ Do not use roasting pans, frying pans or grill stones large enough to cover several burners. The resulting heat accumulation can damage the appliance.
- ▶ If the gas cooktop is installed behind a cabinet door, it must only be used with the door open. Only close the cabinet door when the appliance is switched off.
- ▶ If the gas cooktop has not been used for an unusually long time, it should be thoroughly cleaned before using it again and checked that it is working properly by an authorized expert.
- ▶ Before discarding an old appliance, disconnect it from the gas and electrical supply, and cut off the power cord to prevent it from becoming a hazard.

**SAVE THESE INSTRUCTIONS
AND REVIEW THEM
PERIODICALLY**

Description of the appliance

Cooktop

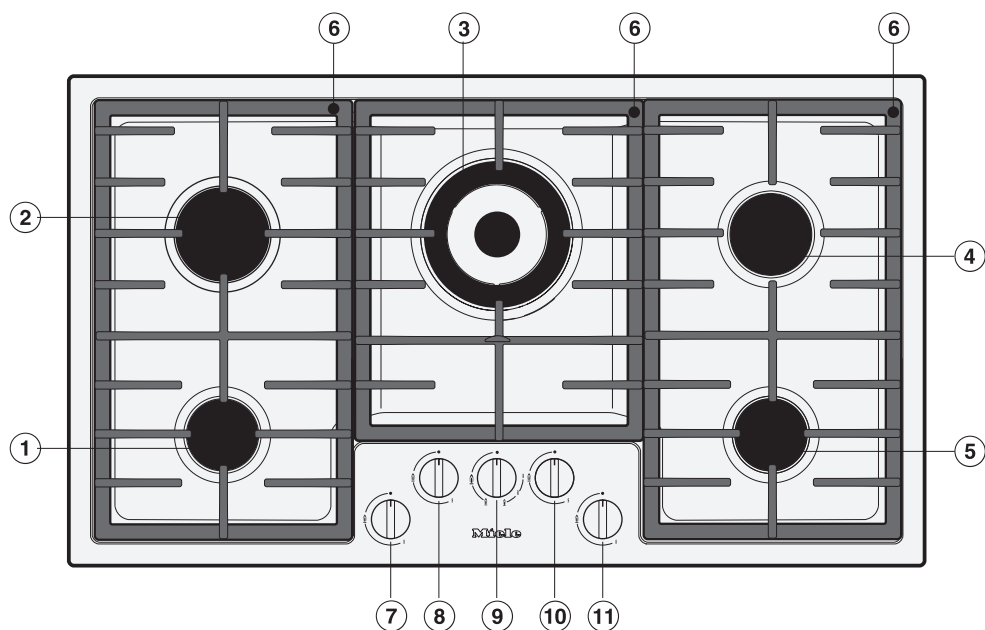

- ① Auxiliary burner
- ② High-speed burner
- ③ Double-insert super burner
- ④ Normal burner
- ⑤ Normal burner
- ⑥ Grate (three pieces)

- Controls:
- ⑦ Front left
 - ⑧ Back left
 - ⑨ Middle
 - ⑩ Back right
 - ⑪ Front right

Description of the appliance

Burners

Double-insert super burner

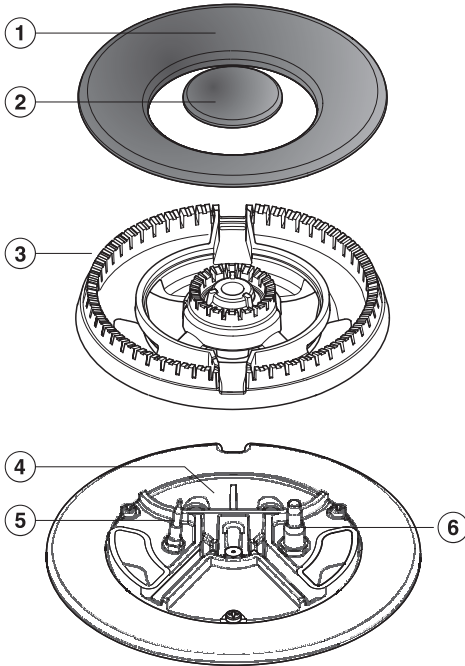

- ① Outer burner cap
- ② Inner burner cap
- ③ Burner head
- ④ Burner base
- ⑤ Ignition safety device
- ⑥ Ignitor

Auxiliary, normal and high-speed burners

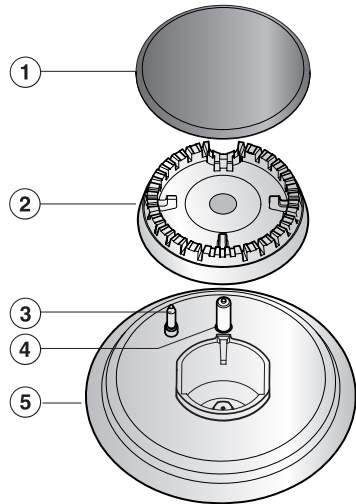

- ① Burner cap
- ② Burner head
- ③ Ignition safety device
- ④ Ignitor
- ⑤ Burner base

Description of the appliance

Standard accessories

You can re-order standard accessories and optional accessories as needed.

Wok ring

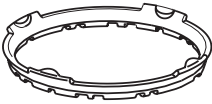

The wok ring (supplied) is included for added stability, especially for woks with round bases.

Trivet



For small and large pans, see "Cookware".

Adhere the data plate sticker, which is included with the appliance documents, on the appropriate place marked in "Technical Service".

Cleaning the cooktop

- Remove any protective films.
- Wash the removable parts of the gas burner in a mild solution of warm water and liquid dish soap.
- Dry and reassemble the parts in the correct order (see "Cleaning and care").
- Wipe the cooktop with a damp cloth and dry thoroughly.

Metal components have a protective coating which may give off a slight odor the first time your new appliance is heated.

The harmless odor will dissipate after a short time and does not indicate a faulty connection or appliance defect.

Using the cooktop

To turn the burner on, press and turn the knob toward the LEFT only. To turn the burner off, turn the knob to the RIGHT only. The outer burner of the double-insert super burner requires you to press the knob down while turning it in order to get from the high flame to the low flame zone.

The appliance can be **damaged** if you:

- turn the knob without pressing,
- turn to the right to turn on,
- turn to the left to turn off.

Control knobs

With the control knob you ignite the burner and adjust the size of the flame.

Auxiliary, normal and high-speed burners

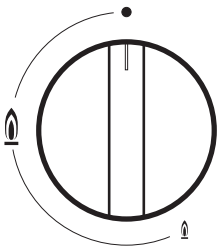

- The gas supply is turned off
- 🔥 Strongest flame
- 🔥 Weakest flame

Double-insert super burner

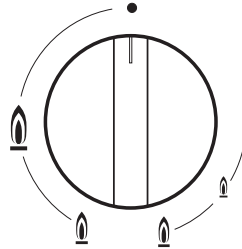

- The gas supply is turned off
- 🔥 Strongest flame:
The inner and outer burners operate at the highest setting.
- 🔥 Strong flame:
The outer burner operates at the lowest setting, the inner burner at the highest setting.
- 🔥 Weak flame:
The outer burner is switched off, the inner burner operates at the highest setting.
- 🔥 Weakest flame:
The outer burner is switched off, the inner burner operates at the lowest setting.

Turning on

 Do not leave the appliance unattended whilst it is being used.

- To light the burner, press the corresponding burner control knob and turn it to the left to the largest flame symbol.

Pressing a burner control knob automatically generates a spark at all burners on the cooktop. This is normal and does not indicate a faulty appliance.

- When a flame is visible, keep the burner control knob pressed for 8 - 10 seconds, then release it.
- If the flame goes out prematurely, turn the burner control knob to "●". Wait at least 1 minute before attempting to reignite. You may have to keep the burner control knob pressed a little longer.
- If the burner does not ignite even at the second attempt, turn the burner control knob to "●" and read the chapter on "Frequently asked questions".

Turning on in the event of a power failure

If there is a power loss, you can ignite the flame manually, e.g. with a match.

- Press the burner control knob and turn it to the left to the largest flame symbol.
- Keep the knob pressed and ignite the escaping gas-air mixture with a match.
- Keep the knob pressed for a further approx. 8 - 10 seconds and then release it.

Using the cooktop

Regulating

The inner and outer burners of the **double-insert super burner** are both controlled by one control knob. There is a stop at the 6 o'clock position that requires you to press the knob down while turning it in order to get from the high flame to the low flame zone.

- To reduce the flames from a high to a low setting, turn the burner control knob counterclockwise until resistance is felt. Press the knob down until you pass the stop, and release the pressure and set the cooktop the desired setting.
- To increase the flames from a low to a high setting, turn the burner control knob clockwise until resistance is felt. Press the knob down until you pass the stop, and release the pressure and set the cooktop the desired setting.



The flame should be regulated so that it never protrudes beyond the pot. Since the outer part of the gas flame is much hotter than the center of the flame, the flame tips should remain under the base of the pot. Protruding flame tips give off unnecessary heat into the air and can damage pot handles and increase the risk of burning.

The burner can be continuously regulated between the highest and lowest flame. Exception: double-insert super burner.

Turning off

- Turn the burner control knob clockwise to "●".

The gas supply is stopped and the flame goes out.

Do not turn the burner control knob clockwise beyond "●".

Pan size

- Select the cookware to match the burner:
large diameter = large burner
small diameter = small burner.
- Using oversized pans may cause the flames to spread out and damage the surrounding countertop or other countertop appliances. The proper pan size will also improve efficiency.
- Pots with a smaller diameter than the grate(s) and pots that do not sit securely (without wobbling) are hazardous and should not be used.

Suitable pans

- Unlike pans used on an electric cooktop, the bases do not need to be even for good results.
- When buying pots and pans, keep in mind that it is generally not the base diameter but the upper diameter which is specified.
- Only use heat-resistant cookware.
- Thick pan bases will give more even results, as hot spots are reduced due to better heat distribution.
Thin pan bases will conduct the heat faster but not as evenly as thick pan bases. Stir the food frequently to prevent burning.



- Do not use pots or pans with edge-supported bases. between the burner and the base of the wok pan above it.

Pan placement

- Always place the cookware on the grate. The cookware must not be placed directly on the burner.
- Position the cookware on the grate so that it cannot tip over. A minimum amount of wobbling can never be completely ruled out.

Wok ring

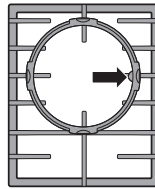

For added stability, especially for wok pans with round bases, use the wok ring (supplied).

Make sure the wok ring is properly in place, so that it won't move around. (See illustration.)

Trivet

The trivet must be used on the **double-insert super burner**, if using

- very small cookware. Prevents it from tipping over.
- very large cookware. Using the insert will prevent the flames from spreading, causing the cooktop to discolor and the surrounding countertop to be damaged.

Energy saving tips

- If possible, cook in covered pots or pans. This prevents unnecessary heat loss.
- Cook with less water.
- The cooking time can be significantly reduced by using a pressure cooker.
- After cooking or frying, promptly set to a lower flame.

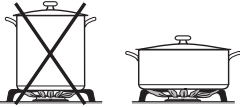

- Generally, wide / shallow pans will heat quicker and cook more evenly than narrow / tall ones.

Ignition safety control

The appliance is equipped with an Ignition safety control. This control cuts the gas supply if the flame goes out, e.g. from a boilover or a draft. Any further escape of gas is prevented.

- To reignite the burner knob clockwise to "●" and then turn it on as usual.

The Ignition safety control works independently of the power supply. It is active if the appliance is in use during a power failure.

Cleaning and care

 Never use a steam cleaner to clean this cooktop. Pressurized steam could cause permanent damage to the surface and to components.

Keep the ignitor in the burner dry. If it gets wet it will not spark.

- Clean the appliance after each use. Let the appliance cool to a safe temperature before cleaning.
- Dry your cooktop thoroughly after cleaning it to prevent lime deposits.
- Soak baked or hardened spills.
- **Remove any soiling immediately!** Spilled food may discolor the burners or the stainless steel.
- The surfaces of the burner parts and grates become slightly duller over time. This is normal and does not indicate any impairment of the material.

To better maintain your appliance avoid the following:

- cleaners containing soda, ammonia, thinners, or chlorides,
- cleaners containing descaling agents or lime removers,
- stain and rust removers,
- abrasive cleaners,
- cleaners containing solvents,
- dishwasher soap,
- caustic (oven) cleaners,
- glass cleaners,
- scouring pads, steel wool, hard brushes, metal scrapers.
- sharp objects (they could damage the seals between the frame and the countertop).

Cleaning and care

	Cleaning	Tips
Stainless steel	<p>Clean with a sponge and a mild solution of liquid dish soap and warm water.</p> <p>If necessary, use the rough side of the sponge and the Miele Ceramic and stainless steel cleaner. Make sure to only use the product in the direction of the grain.</p> <p>To keep the surfaces from quickly becoming soiled again, we recommend treatment with the Miele stainless steel care product. Using a soft cloth, apply the product in a thin, even layer.</p>	<p>Printed surfaces (flame symbols)</p> <p>Remove any soiling which comes into contact with the printed flame symbols and the Miele logo right away. Soiling, particularly salty food or liquid and olive oil, can cause damage if left on the printed surfaces for too long. Do not use stainless steel cleaning agents on the printed surfaces. This can rub off the print.</p>
Grates	<p>Take off the grates.</p> <p>Clean in the dishwasher or with a sponge and a mild solution of liquid dish soap and warm water.</p> <p>If necessary, use the rough side of the sponge.</p>	<p>Lighter spots on the grates may be caused from soap residue or from the rubbing of pot or pan bottoms. Clean as indicated in the adjacent column.</p>
Burner control knobs	<p>Clean with a sponge and a mild solution of liquid dish soap and warm water.</p>	Not dishwasher-safe.
Burner caps	<p>Clean with a sponge cloth, a mild solution of liquid dish soap and warm water.</p> <p>If necessary, use the rough side of the sponge</p>	Not dishwasher-safe.
Burner head	<p>Clean with a sponge and a mild solution of liquid dish soap and warm water.</p> <p>If necessary, use the rough side of the sponge</p>	<p>Not dishwasher-safe.</p> <p>Make sure that the flame openings are completely dry after cleaning.</p>
Ignitor Ignition safety control	<p>Wipe carefully with a damp cloth.</p>	<p>Do not allow the Ignitor to get wet, otherwise it will not spark.</p>

Cleaning and care

Auxiliary, normal and high-speed burners

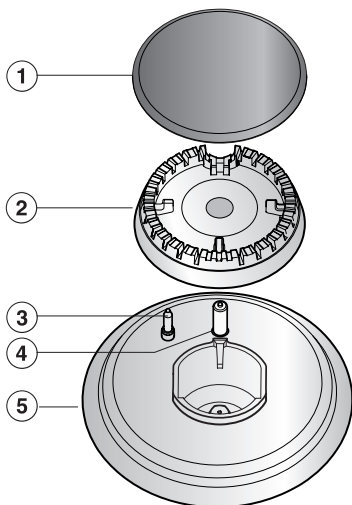

- Place the burner head ② on to the burner base ⑤ so that the ignition safety device ③ and the ignitor ④ extend through their respective holes in the burner head. The burner head must click into place correctly.
- Place burner cap ① flat over burner head ②. When correctly positioned it will not slide about.

To assemble the double-insert super burner

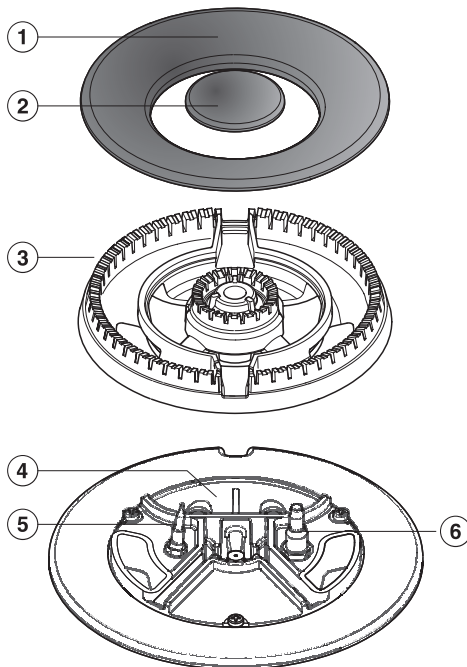

- Place burner head ③ onto burner base ④ so that the ignition safety device ⑤ and the ignitor ⑥ extend through their respective holes in the burner head. The burner head must click into place correctly.
- Place the burner caps ① and ② in position.

Important: replace parts in the correct order after cleaning.

Frequently asked questions

 Repairs should only be carried out by an authorized technician in accordance with local and national safety regulations. Unauthorized repairs could cause injury or appliance damage.

Problem	Cause and solution
The burner doesn't ignite when lit for the first time, or when it has not been used for an unusually long time.	There might be air in the gas pipe. ■ Repeat lighting several times Wait at least 1 minute before attempting to reignite. You may have to keep the burner control knob pressed a little longer.
The burner does not ignite after several attempts	The burner is not assembled correctly. ■ Assemble the burner correctly.
	The gas valve is closed. ■ Open the gas valve.
	The burner is wet and/or soiled. ■ Clean and dry the burner.
	The flame holes in the burners are soiled and clogged. ■ Clean and dry the flame holes.

Frequently asked questions

Problem	Cause and solution
Gas flame goes out after ignition.	<p>The flames don't reach the ignition safety device, it doesn't get hot enough.</p> <ul style="list-style-type: none">– The burner is assembled incorrectly. <p>■ Position the burner parts correctly.</p> <ul style="list-style-type: none">– The ignition safety device is soiled. <p>■ Remove the soiling.</p>
The shape of the gas flame varies	<p>The burner parts are not positioned correctly.</p> <p>■ Position the burner parts correctly.</p>
	<p>The burner head or the flame holes are soiled.</p> <p>■ Remove the soiling.</p>
Gas flame goes out	<p>The burner parts are not positioned correctly.</p> <p>■ Position the burner parts correctly.</p>
The burner ignitor is not working	<p>The circuit breaker has tripped.</p> <p>■ Contact Miele Technical Service.</p>
	<ul style="list-style-type: none">– There is food residue between the ignitor and the burner cap.– There is food residue at the ignition safety device. <p>■ Remove the soiling.</p>

In the event of a fault which you cannot easily fix yourself, please contact the Miele Technical Service Department at the address on the back of this booklet. When contacting Technical Service please quote the serial number and model of the cooktop. This information is visible on the silver data plate supplied with the cooktop. Adhere the data plate sticker to the box below:

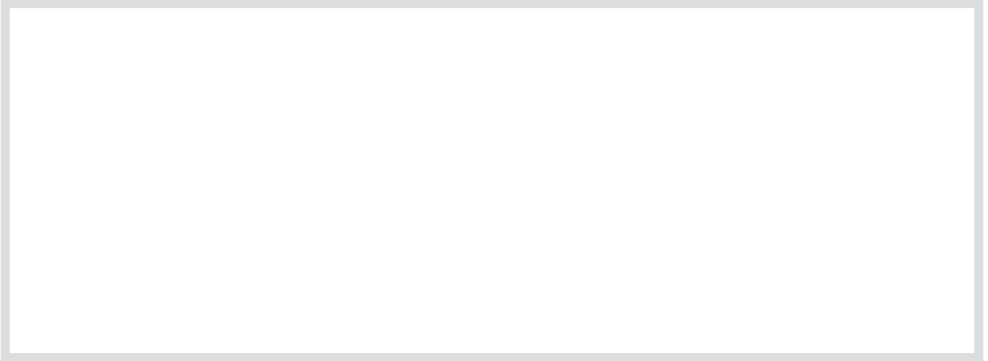

MieleCare

MieleCare, our Extended ServiceContract program; gives you the assurance of knowing that yourappliance investment is covered by 5 years of worry free ownership. **MieleCare** is the only Extended Service Contract in the industry that guarantees repairs by a Miele Authorized Service Provider using genuine Miele parts. Only genuine Miele parts installed by factory trained professionals can guarantee the safety, reliability and longevity of your Miele appliance.

Please note that unless expressly approved in writing by the Miele Service department, Extended Service Contracts offered by other providers for Miele products will not be recognized by Miele. Our goal is to prevent unauthorized (and untrained) service personnel from working on your Miele products, possibly doing further damage to them, you and/or your home.

To learn more about **MieleCare** Extended Service Contracts, please contact your appliance dealer or visit us online at:

<http://mieleusa.com/mielecare>

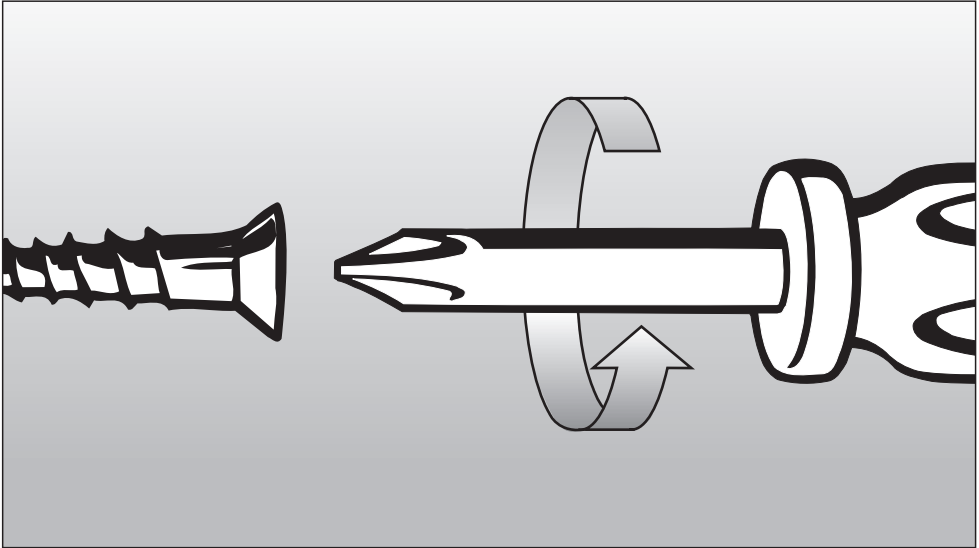

Installation Instructions

IMPORTANT: SAVE FOR THE LOCAL ELECTRICAL INSPECTOR'S USE

Information is subject to change. Please refer to our website to obtain the most current product specification, technical & warranty information.

To prevent accidents
and appliance damage
read these instructions
before
installation or use.

IMPORTANT INSTALLATION SAFETY INSTRUCTIONS

Installation

The minimum distances given in these Installation instructions are to combustible surfaces, and must be observed to ensure safe operation. Failure to do so increases the risk of fire.

The cabinetry and venting hood should be installed first to prevent damage to the cooktop.

- ▶ Gas appliances should only be installed in a well ventilated area.
- ▶ The countertop must be bonded with heat resistant (212°F/100°C) adhesive to prevent distortion or dissolving. Any wall coverings must be heat resistant as well.
- ▶ This appliance must not be used in a non-stationary location (e.g. on a ship).
- ▶ Deep fat fryers must not be installed directly next to gas cooktops. Gas flames can ignite splattering oil. A distance of at least 11 $\frac{3}{4}$ " (300 mm) should be maintained between these two appliances.
- ▶ The cooktop must not be installed over a dishwasher, washer, dryer, refrigerator or freezer. Heat radiated by the cooktop may damage the appliances.
- ▶ Install the appliance so that the power cord or gas piping does not come into contact with any portion of the cooktop which may become hot during use.

▶ The power cord and a flexible gas connection line must be attached in such a way that they are not in contact with moving parts of kitchen elements (e.g. a drawer) and are not subject to mechanical stress.

▶ The safety distances listed on the following pages must be carefully maintained.

▶ Never use a sealant unless expressly stipulated. The sealing tape of the appliance ensures adequate sealing to the countertop.

This appliance must be installed with its own shut off valve and the included gas pressure regulator. Both the valve and the regulator must be easily accessible to the consumer after the appliance is installed.

This appliance must be disconnected from the gas supply during any pressure testing of the system performed in excess of $\frac{1}{2}$ psi (3.5 kPa). This appliance must be isolated at test pressures equal to or less than $\frac{1}{2}$ psi (3.5 kPa).

Any pipe connections must be made using a thread sealant approved for gas connections. Failure to correctly install these items could lead to a gas leak and subsequent explosion.

In Massachusetts installation must be performed by a licensed plumber/gas fitter.

IMPORTANT INSTALLATION SAFETY INSTRUCTIONS

Safety distances above the appliance

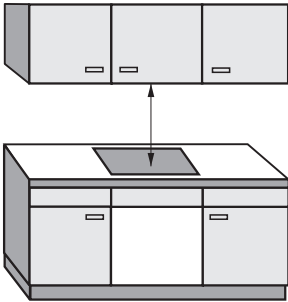

If there are several appliances beneath a hood, and they have different minimum safety distances always observe the greatest distance.

The minimum safety distance given by the hood manufacturer must be maintained between the cooktop and the hood above it. See the installation instructions of the hood for these safety measurements.

If the hood manufacturer's instructions are not available or if flammable objects are installed over the cooktop (e.g. cabinets, utensil rail, etc.), a minimum safety distance of 30" (760 mm) must be maintained.

IMPORTANT INSTALLATION SAFETY INSTRUCTIONS

Safety distances

When installing a gas cooktop, there may be cupboard or room walls of any size on the rear side and on one side (right **or** left) (see illustrations).

The following minimum safety distances must be maintained:

- ① 2" (50 mm) minimum distance at the **rear** of the countertop cutout to the rear edge of the countertop.
- ② 5 7/8" (150 mm) minimum distance to the **right** of the countertop cutout to an adjacent piece of furniture (e. g. tall cabinet) or room wall.
- ③ 5 7/8" (150 mm) minimum distance to the **left** of the countertop cutout to an adjacent piece of furniture (e. g. tall cabinet) or room wall.

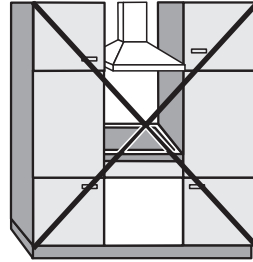

Not allowed

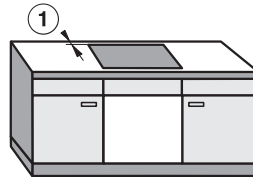

Recommended

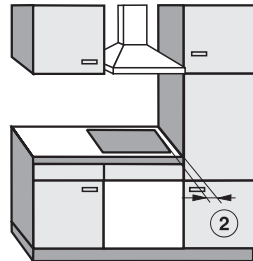

Not recommended

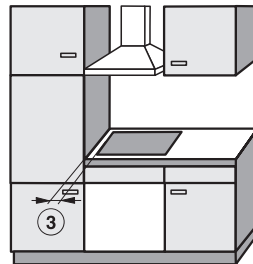

Not recommended

Installation dimensions

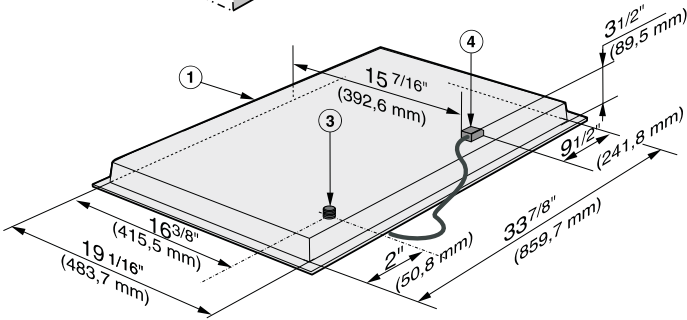
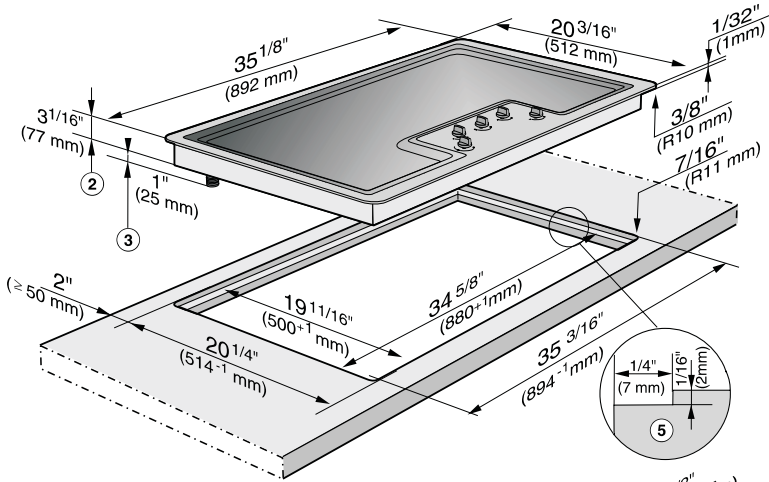

- ① Appliance front
- ② Installation height
- ③ Gas connection
- ④ Power supply box with connection cable, L = 4 ft (1.2 m)
- ⑤ Stepped cut-out for granite or marble worktops

Please take careful note of the detailed diagrams for the cut-out dimensions in granite and marble countertops.

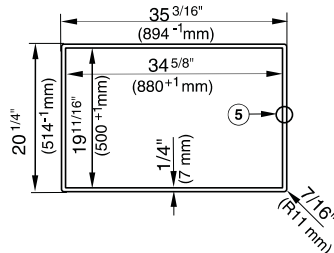

Installation

Flush mounted gas cooktops are only suitable for installation in granite, marble, tiled or solid wood countertops.

If installing into a countertop made from any other material, please check first with the countertop manufacturer that it is suitable for installing a flush mounted cooktop.

This appliance requires a 36 7/16" (900 mm) wide base unit for installation.

The cooktop must be accessible from below for servicing purposes and to ensure that the seal around it is not dislodged.

The cooktop may be installed:

- in a suitable cut-out in a granite or marble countertop.
- in a suitable cut-out in a tiled or solid wood countertop with a wooden support frame. The frame must be provided on site, and is not supplied with the appliance.

Granite and marble countertops

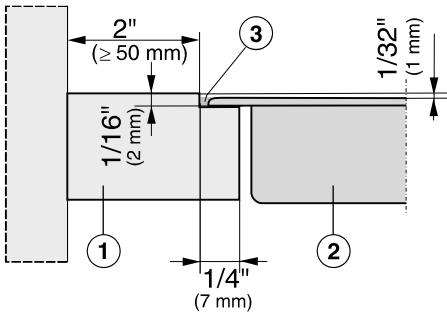

- ① Countertop
- ② Cooktop
- ③ Gap

As the ceramic glass and the countertop cut-out have a certain dimensional tolerances, the size of gap ③ can vary.

- Make the countertop cut-out as shown in "Installation dimensions". Remember to maintain the **minimum safety distances** (see "IMPORTANT INSTALLATION SAFETY INSTRUCTIONS").
- Feed the power cord down through the cut-out.
- Center the cooktop ② in the cut-out.
- Connect the cooktop to the mains (see "Electrical connection").
- Connect the appliance to the gas supply (see "Gas connection").
- Secure the appliance at the back and front using the brackets supplied. See "Securing the appliance".
- Check that the cooktop works.
- Seal the remaining gap ③ with a silicone sealant that is heat-resistant to at least 320 °F (160 °C).

For granite and marble countertops, only use silicone sealant that is especially formulated for granite and marble, and observe the sealant manufacturer's instructions.

Installation

Solid wood and tiled worktops

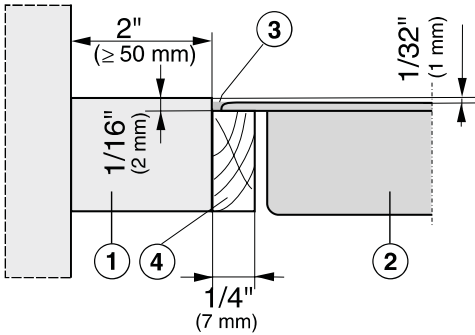

- ① Countertop
- ② Cooktop
- ③ Gap
- ④ Wooden frame 1/4" (7 mm)
(to be provided on site)

As the ceramic glass and the countertop cut-out have a certain dimensional tolerance, the size of gap ③ can vary.

- Make the countertop cut-out as shown in "Building-in dimensions". Remember to maintain the **minimum safety distances** (see "IMPORTANT INSTALLATION SAFETY INSTRUCTIONS").
- Fix the wooden frame ④ 1/16" (2 mm) below the top edge of the countertop (see diagram).
- Feed the power cord down through the cut-out.
- Center the cooktop ② in the cut-out.
- Connect the cooktop to the mains (see "Electrical connection").
- Connect the appliance to the gas supply (see "Gas connection").
- Secure the appliance at the back and front using the brackets supplied. See "Securing the appliance".
- Check that the cooktop works.
- Seal the remaining gap ③ with a silicone sealant that is heat-resistant to at least 320 °F (160 °C).

Please follow the manufacturer's instructions.
For **granite and marble tiles** only use a silicone sealant that is specifically formulated for granite and marble, and observe the sealant manufacturer's instructions.

Securing the appliance

Secure the appliance as shown, using the fixing brackets supplied.

3/4" (20 mm) countertop

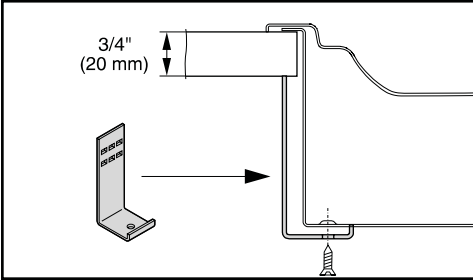

1 1/4" (30 mm) countertop

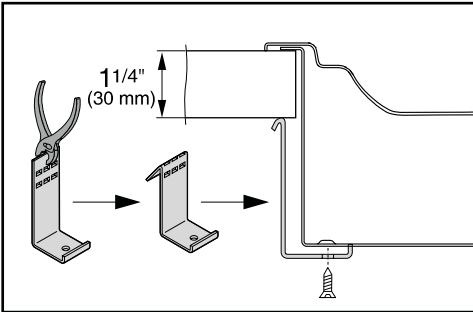

1 1/2" (40 mm) countertop

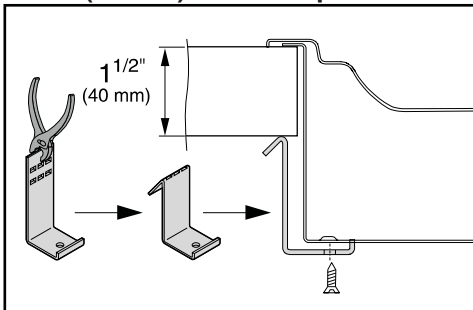

After installation

Check that all the burners are operating correctly.

The flame must not go out on the lowest setting, or when the control is turned quickly from a high to a low setting.

On the highest setting, the flame must have a distinctive and visible core.

Electrical connection

This appliance must be grounded according to local or national codes.

All electrical work should be performed by a qualified electrician in accordance with local codes and with the:

- National Electrical Code ANSI / NFPA No. 70 for the USA

or

- Canadian Electrical Code Part I for Canada (CSA Standard C 22.1).

This appliance is equipped with a three-prong grounding plug to prevent shock hazards. It should be plugged directly into a properly grounded outlet. Do not cut or remove the grounding prong from the plug. If the plug does not fit the outlet, have the proper outlet installed by a licensed electrician.

To guarantee the electrical safety of this appliance, continuity must exist between the appliance and an effective grounding system. It is imperative that this basic safety requirement be met. If there is any doubt, have the electrical system of the house checked by a qualified electrician.

WARNING

Disconnect the appliance from the main power supply before installation or service. To reduce the risk of electric shock, make sure that the appliance is properly grounded after installation.

Note to the installer

Please leave these instructions with the consumer or the appliance.

Power supply

The automatic ignition requires that the appliance be connected to a 120 VAC, 60 Hz power supply. The supply line should be protected by a 15 A fuse.

Actual power consumption (during ignition only) is 25 W.

This appliance is equipped with a 4 ft (1.2 m) long power cord that is ready for connection to the appropriate outlet.

Place the power outlet so that it is accessible after the appliance has been installed in the countertop.

Wiring diagram

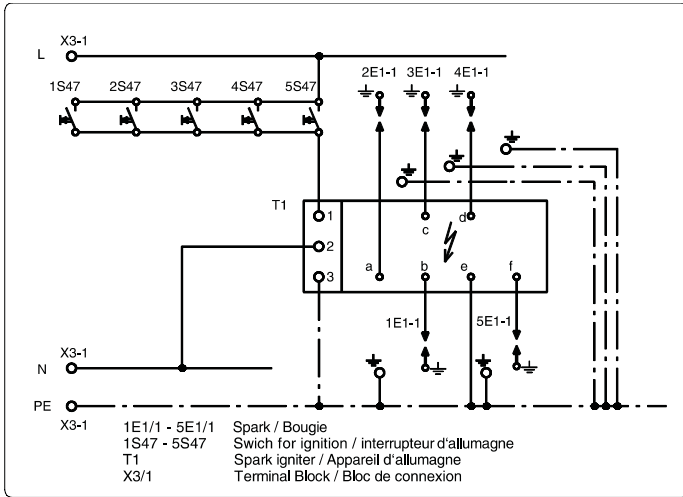

⚠ Caution: Label all wires prior to disconnection when servicing controls. Wiring errors can cause improper and dangerous operation. Verify proper operation after servicing.

Gas connection

Installation and service must be performed by a qualified installer, service agency or gas supplier.

In Massachusetts installation must be performed by a licensed plumber/gas fitter.

This appliance must be installed with its own shut off valve and the included gas pressure regulator. Both the valve and the regulator must be easily accessible to the consumer to turn on or shut off the gas supply after the appliance is installed.

This appliance and its individual shut off valve must be disconnected from the gas supply during any pressure testing of that system performed in excess of ½ psi (3.5 kPa). The appliance must be isolated from the gas supply line by closing its individual manual shut off valve at test pressures equal to or less than ½ psi (3.5 kPa).

Any pipe connections must be made using a thread sealant approved for gas connections. Failure to correctly install these items could lead to a gas leak and subsequent explosion.

Leak testing of the appliance shall be conducted according to the manufacturer's instructions.

The gas connection must be made in accordance with local codes or, in the absence of local codes, with

- the National Fuel Gas Code, ANSI Z 21.1 / NFPA 54 for the USA
- or
- the current Can / CGA B 149.1 and .2 Installation Codes for gas burning appliances for Canada.

Make sure that the maximum gas supply pressure before the gas pressure regulator is never more than ½ psi for both natural gas or LP gas.

The minimum required gas supply pressure to get the required gas input is
6" w.c. for natural gas
10" w.c. for LP gas.

Gas pressure regulator

A pressure regulator that is convertible from natural to LP gas (Propane) or vice versa is included with the appliance. The included regulator corresponds with the gas type of the appliance. Verify before installing.

The adjusted pressure is:
natural gas - 4" w.c.
LP gas - 10" w.c.

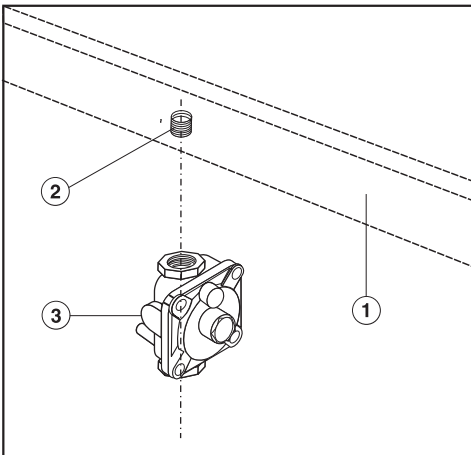

- ① Appliance
- ② 1/2" NPT
- ③ Regulator

As shown in the above diagram, the included regulator **must** be used when connecting the Miele appliance to your gas supply. This item has been customized by Miele to meet all applicable safety requirements. Make sure the regulator is easily accessible for adjustment after the appliance has been installed.

For convenience, an AGA or CGA approved flexible stainless steel gas hose (accordion type) may be used between the gas connection and the regulator. This will allow the appliance to be lifted out of the countertop for cleaning or servicing. Make sure that any drawers, cabinet doors, etc., do not rub on this gas hose.

Do not use any regulator unless it has been supplied by Miele. Doing so may cause a gas leak.

If there is any doubt concerning installation contact the Miele Technical Service Department.

After connecting the appliance check all fittings for gas leaks e.g. with soapy water.

When installed properly, the flame will be steady and quiet. It will also have a sharp, blue inner core that will vary in length proportional to the burner size. Flame adjustment will not be necessary.

Conversion to another type of gas

The appliance should have been ordered for connection to either natural gas or LP gas (propane).

If the appliance is not configured for the proper type of gas connection please contact your Miele Dealer.

If the appliance is to be connected to a type of gas other than it was originally configured for, both the regulator and burners must be converted. A conversion kit is available as an optional accessory from the Miele Technical Service Department.

Burner performance

Rated load at high setting

Burner	Type of gas	KM 2355	
		BTU/hr	kW
Auxiliary burner	Natural gas (NG)	3,900	1.14
	Liquid gas (LP)	3,000	0.88
Normal burner	Natural gas (NG)	5,900	1.73
	Liquid gas (LP)	6,000	1.76
High-speed burner	Natural gas (NG)	9,800	2.87
	Liquid gas (LP)	9,500	2.78
Double-insert super burner	Natural gas (NG)	13,000	3.81
	Liquid gas (LP)	15,000	4.40
Total	Natural gas (NG)	38,500	11.3
	Liquid gas (LP)	39,500	11.6

Rated load at low setting

Burner	Type of gas	KM 2355	
		BTU/h	kW
Auxiliary burner	Natural gas (NG)	1,200	0.35
	Liquid gas (LP)	650	0.19
Normal burner	Natural gas (NG)	1,200	0.35
	Liquid gas (LP)	1,100	0.32
High-speed burner	Natural gas (NG)	1,700	0.50
	Liquid gas (LP)	1,800	0.53
Double-insert super burner	Natural gas (NG)	750	0.22
	Liquid gas (LP)	700	0.21

Help protect our environment

Disposal of packing materials

The cardboard box and packing materials are biodegradable and recyclable. Please recycle.

Ensure that any plastic wrappings, bags, etc. are disposed of safely and kept out of the reach of children.

Danger of suffocation!

Disposal of an old appliance

Old appliances contain materials that can be recycled. Please contact your local recycling authority about the possibility of recycling these materials.

Before discarding an old appliance disconnect it from the electrical supply and cut off the power cord to prevent it from becoming a hazard.

Please have the model and serial number of your appliance available before contacting Technical Service.



U.S.A.
Miele, Inc.

National Headquarters

9 Independence Way
Princeton, NJ 08540
Phone: 800-843-7231
609-419-9898
Fax: 609-419-4298
www.mieleusa.com

Technical Service & Support
Nationwide

Phone: 800-999-1360
Fax: 888-586-8056

TechnicalService@mieleusa.com

Canada
Miele Limited

Headquarters and Showroom

161 Four Valley Drive
Vaughan, ON L4K 4V8
Phone: 800-643-5381
Fax: 905-532-2290
www.miele.ca
professional@miele.ca
(commercial enquiries)

MieleCare National Service

Phone: 800-565-6435
905-532-2272
Fax: 905-532-2292
customercare@miele.ca
(general and technical enquiries)



www.miele-shop.com

KM 2355



en - US

M.-Nr. 09 596 090 / 00