

FISHER & PAYKEL

CLICK ANYWHERE On THIS PAGE to RETURN to GAS COOKTOP INSTALLATION GUIDES at [InspectApedia.com](https://www.inspectapedia.com)

Installation Instructions

Last updated: Nov 7, 2018



Preparing for the Installation

Be sure to read the section on the proper ventilation requirements before you begin.

1. Unpack the unit, the regulator, and remove all packing between all the burners, rings, and caps. Remove the grates from their boxes.
2. With the necessary tools and hardware ready, measure the distance from the back and sides of the countertop and cabinet to locate the position of the cooktop Cutout.
3. Make your Cutout according to the dimensions in section 'Cutout and Cabinetry Dimensions'. Square the cutout to the countertop.
4. Lower the cooktop into the countertop cutout, being careful not to damage the counter, inlet pipe threads, or the power cord of the cooktop.
5. Square the cooktop to the cutout and install the (4) retaining brackets onto the 8 holes for CDV2-365 and (2) retaining brackets onto 4 holes for CDV2-304 located at the bottom of the unit (See Figure 1 below). If the retaining brackets are not installed, the cooktop will not pull down to countertop.
6. Tighten the 4 preloaded thumb screws which will keep the unit secured. Do Not Over-tighten (See Figure 2 detail below).





Some installations may not have adequate clearance at the front for the 'Z'-shaped retaining bracket. In those cases, use the 'L'-bracket provided. Fasten the bracket to the bottom of the cooktop chassis using one of the screw holes provided for the retaining brackets. Make sure the bracket extends out far enough to contact the inside of the cabinet face. While pushing down on the front edge of the cooktop from above, attach the bracket to the cabinet.

This step will insure that the edge of the cooktop is flush with the counter surface. Plug the adjacent unused hole in the cooktop chassis with a screw. See Figure 3.

-
7. Install the regulator with the arrow in the direction of the gas flow (towards the cooktop) using a sealant on the male pipe threads. Put burner rings and burner caps in place.
 8. Connect the gas line to the unit. Refer to section 'Gas hook-up'.
 9. Open the manual valve to let the gas flow. Check for gas leak.



Leak-testing of the appliance shall be conducted according to the manufacturer's instructions. See section 'Leak testing' for instructions.

-
10. Plug the unit into a wall outlet.
 11. Turn the front burner knob on first and apply a match to the burner until the gas lights, being cautious not to burn your hand or other parts of your body. When the gas is first activated, there is air present in the gas lines. The match applied to the burner makes it easier and safer to clear the air/gas mixture. Use Caution to avoid burn injury.
 12. Put grates in place.

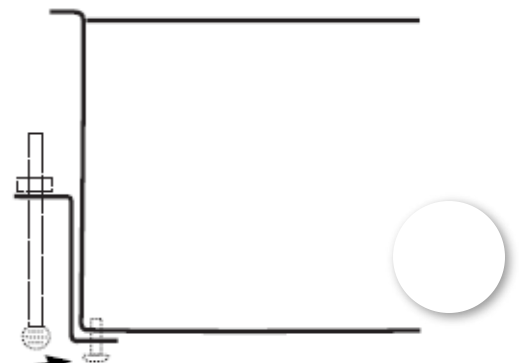
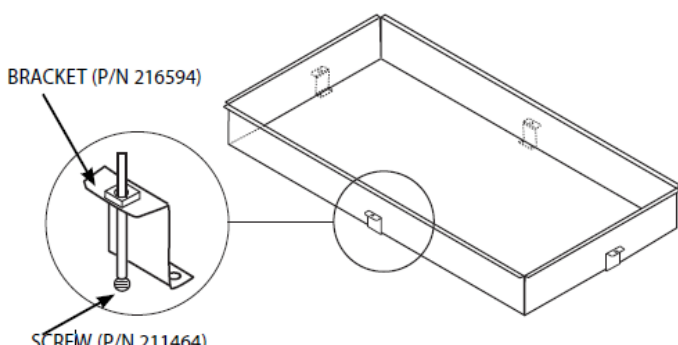

SCREW (P/N 211241)

Fig. 1

Fig. 2

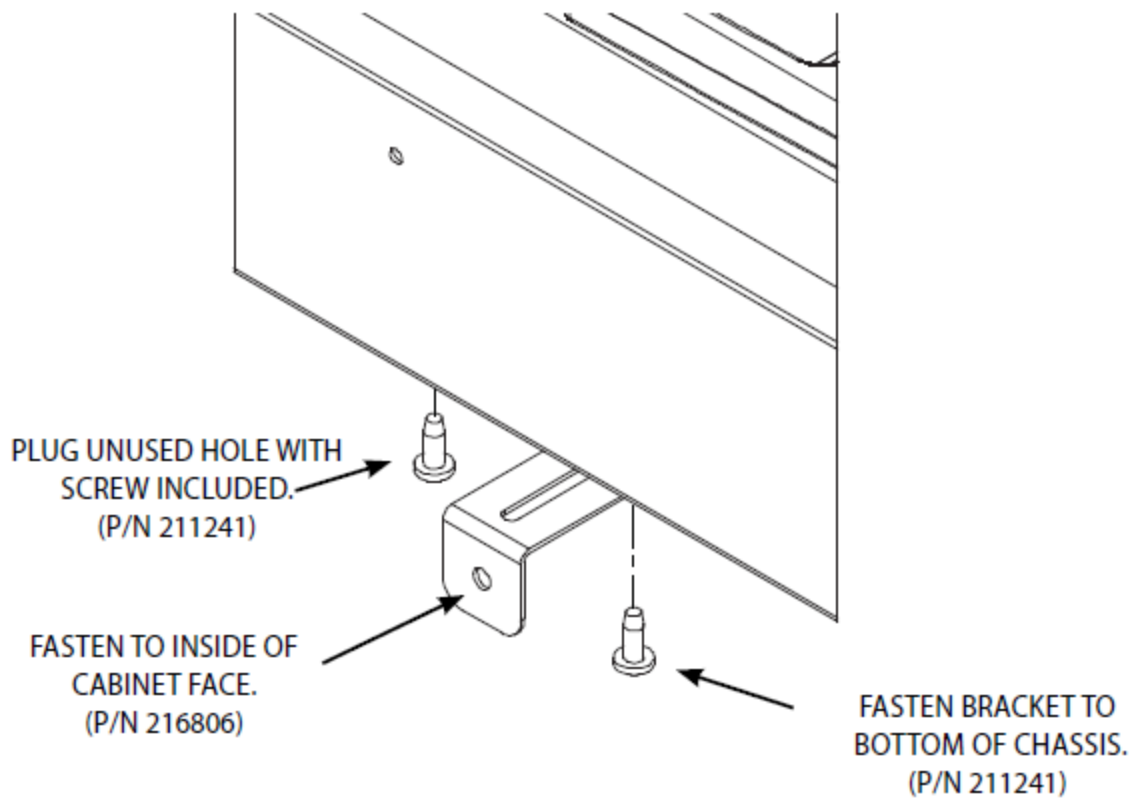

Fig. 3

Cabinet Preparation

For a snug and secure fit, it is critical that the cabinet cutout matches the cutout dimensions provided for the cooktop. See the relevant illustrations in section 'Cutout and Cabinetry Dimensions' for specifications.



- For proper performance, the Drop-In Cooktop must be level. To achieve a flush fit of the cooktop, it will be necessary to have a flat countertop (front to back and left to right).
- Be sure to check local building codes for the proper method of installation. Local codes may vary. Installation, electrical connections, and grounding must comply with all applicable codes.
- To eliminate the risk of burns or fire by reaching over heated surface units, cabinet storage space located above the surface units should be avoided. If cabinet storage is to be provided, the risk can be reduced by installing a rangehood that projects horizontally a minimum of 5 inches beyond the bottom of the overhead cabinets.
- The maximum depth of overhead cabinets installed above the cooktop or on either side of a ventilation hood is 13".



The cooktop must be completely removed from the cutout for service. The cooktop chassis is not supported by the counter. Instructions for removal for service are included in the service summary, attached to the bottom of the cooktop chassis.

Product Dimensions

Top View

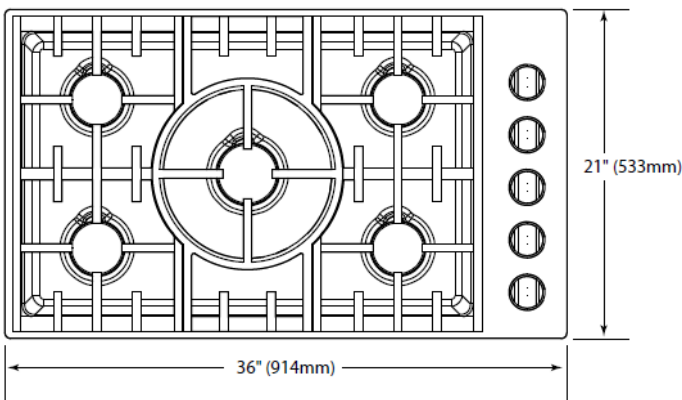

Top View

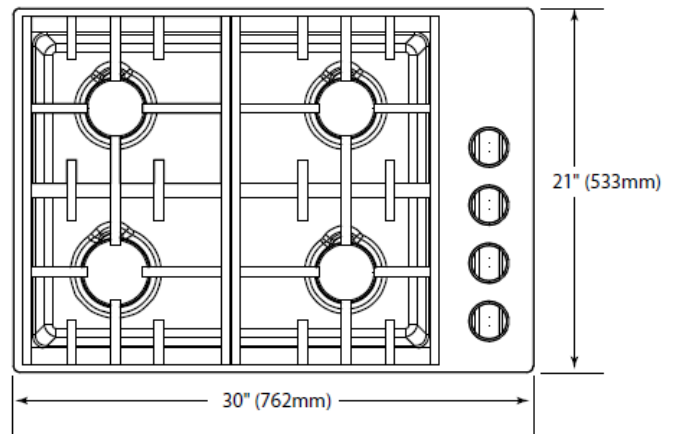

Front View

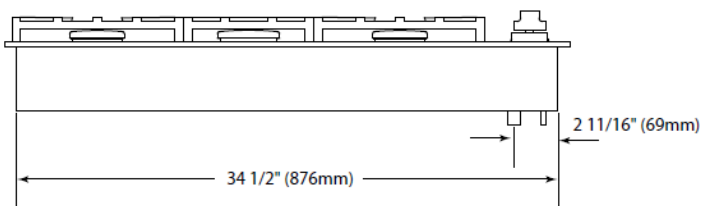

Front View

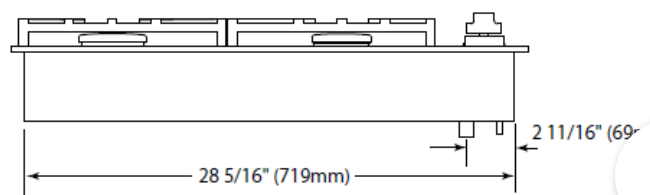

Right Side View

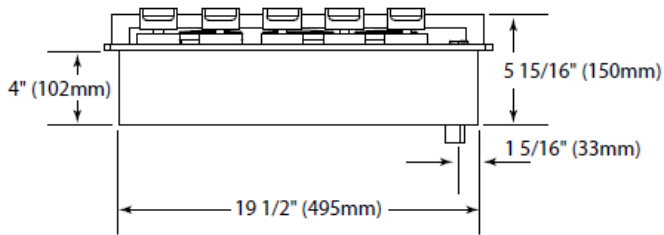

Right Side View

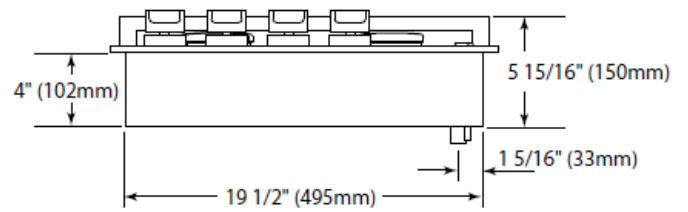

Cutout & Cabinetry

When Installing with a Rangehood

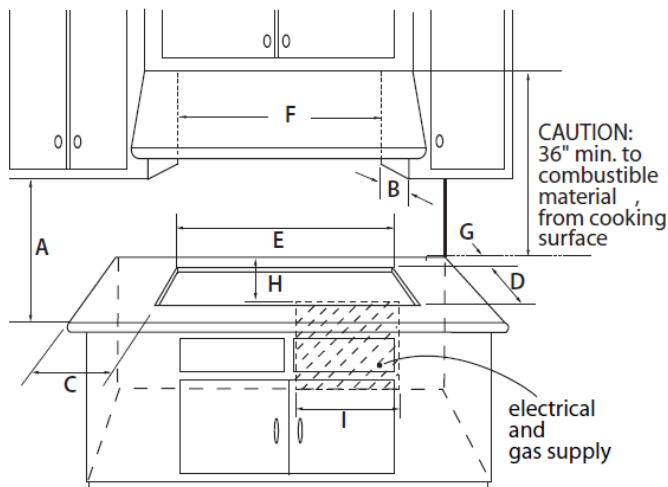

- A) 18" MIN.
- B) 13" MAX.
- C) 12" MIN. TO COMBUSTIBLES FOR ALL MODELS
- D) 19-3/4" DEPTH
- E) 34-3/4" FOR CDV2-365 MODELS
28-5/8" FOR CDV2-304 MODELS
- F) 36" HOOD WIDTH MIN. FOR CDV2-365 MODELS
30" HOOD WIDTH MIN. FOR CDV2-304 MODELS
- G) 7" TO COMBUSTIBLES FOR ALL MODELS
- H) 5"
- I) 18"



*Non-combustible Surfaces

as defined in 'National Fuel Gas Code' (ANSI Z223.1, Current Edition). Clearances from non-combustible materials are not part of the ANSI Z21.1 scope and are not certified by UL. Clearances must be approved by the local codes and/or by the local authority having jurisdiction. See manufacturer's recommendations for ducting specifications.



When Installing with a Fisher & Paykel DD-36 or DD30 Downdraft Ventilation System

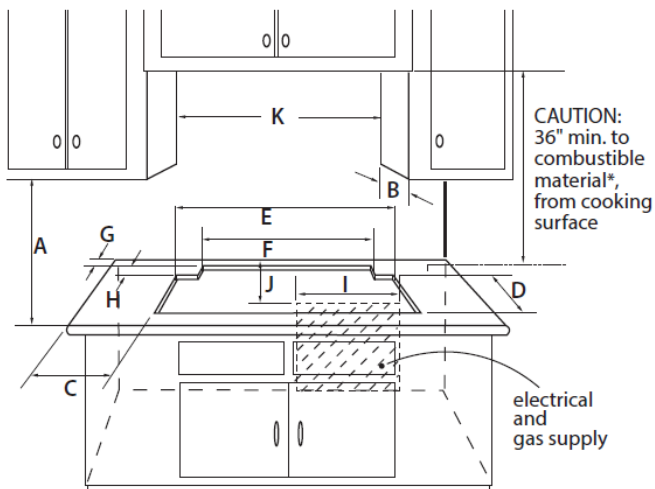

- A) 18" MIN.
- B) 13" MAX.
- C) 12" MIN. TO COMBUSTIBLES FOR ALL MODELS
- D) 19-3/4" DEPTH
- E) 34-3/4" WIDTH FOR CDV2-365 MODELS
28-5/8" WIDTH FOR CDV2-304 MODELS
- F) 33-1/2" WIDTH FOR DD36
27-1/2" WIDTH FOR DD30
- G) 1/2" MIN. TO COMBUSTIBLES FOR ALL MODELS
- H) 2-5/8"
- I) 9"
- J) 26-1/2"
- K) MIN. 36" FOR CDV2-365 MODELS
MIN. 30" FOR CDV2-304 MODELS



**Non-combustible Surfaces*

*as defined in 'National Fuel Gas Code' (ANSI Z223.1, Current Edition).
Clearances from non-combustible materials are not part of the ANSI*



Z21.1 scope and are not certified by UL.

Clearances must be approved by the local codes and/or by the local authority having jurisdiction.

Notes:

- See manufacturer's recommendations for ducting specifications.
 - The horizontal surfaces of the cooktop trim must NOT BE below countertop level.
 - When installing a 30" Cooktop with a Downdraft (DD-30SS), a minimum of a 26" cabinetry depth is required.
-
-

Gas Hook Up

- The gas supply connections should be made by a qualified technician and in accordance with local codes and ordinances.
- Before connecting the appliance to the gas supply, make sure that the gas supply is turned off at the wall valve.
- See the diagrams further below for gas connection details.
- The cooktop and gas pressure regulator are shipped from the factory set for Natural gas or LP (Propane), depending on the specific model ordered. Check the gas type label on the underside of the chassis. Before proceeding any further, check the type of gas supplied to the site of installation and verify that the cooktop is compatible with it. If the cooktop is not set for the type of gas supplied to the site of installation, return it to the dealer.
- The cooktop is designed to operate on:
 - Natural gas LP (Propane)
 - Manifold pressure 4.0" W.C. 10.0" W.C.
 - Incoming line pressure 6.0"–9.0" W.C. 11.0–14.0" W.C.
 - Check the rating label on the underside of the cooktop chassis.
- The supplied gas pressure regulator can withstand a maximum incoming line pressure of 14.0" W.C. If the line pressure is higher, a step-down regulator will be required.
- A gas pressure regulator must be used. Never connect an unregulated gas line to this cooktop. Failure to use a regulator can result in damage or personal injury.
- For checking the regulator setting, the incoming line pressure must be at least 5" W.C. for Natural gas and 11.0" W.C for LP (Propane), ie at least 1.0" W.C. higher than the manifold pressure.
- A manual shut-off valve (supplied by the installer) must be installed in an accessible location in the gas line external to the appliance for the purpose of turning on or shutting off gas to the appliance. (In Massachusetts, such shut-off devices should be approved by the Board of State Examiners of Plumbers & Gas Fitters).
- The appliance and its individual shut-off valve must be disconnected from the gas supply piping system during any pressure testing of that system at test pressures in excess of ½ psi (3.5 kPa).
- The appliance must be isolated from the gas supply piping system by closing its individual shut-off valve during pressure testing of the gas supply piping system at test pressures equal to or less than ½ psi (3.5 kPa).
- The flex line for the gas supply must be new, made of metal, and approved for appliance use by a certifying agency

(CSA, CGA, or UL). Never use an old hose or a hose made of rubber or other synthetic material, as the heat may cause the hose to melt and develop leaks.

- The flex line for the gas supply must be 1/2" NPT, with a minimum diameter of 5/8".

Leak Test

- After final gas connection is made, turn on manual gas valve and test all connections in gas supply piping for gas leaks with a soapy water solution. During this test all appliance gas valves have to be closed.
- In order to avoid property damage or serious personal injury, never use a lighted match or open flame. If a leak is present, tighten joint or unscrew, apply more joint compound, tighten again and retest connection for leak.

Gas Connection for CDV2-365 Models

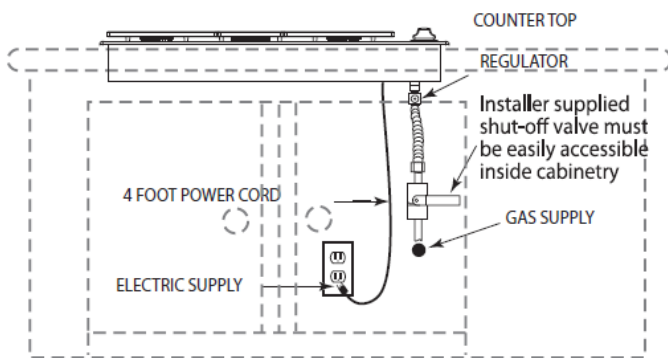

Gas Connection for CDV2-304 Models

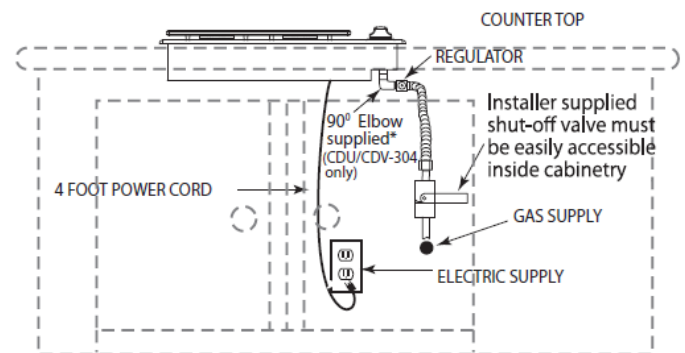

* Required when unit is installed over Wall Oven

Power Requirements

120 VAC, 60 Hz., single phase.

CDV2-365 & CDV2-304 models: 0.10 Amp. Max.

(Use 15 Amp. circuit minimum)

- Always disconnect the electric supply cord from the wall outlet or turn off the electricity at the service disconnect before servicing this appliance.
- Observe all governing codes and ordinances when grounding, in the absence of which, observe National Electrical Code ANSI/NFPA No. 70-1990.
- Wiring diagrams are included in the service summary, attached to the bottom of the cooktop chassis.
- The rating label is located on the bottom of the cooktop chassis, towards the front on the right-hand side.



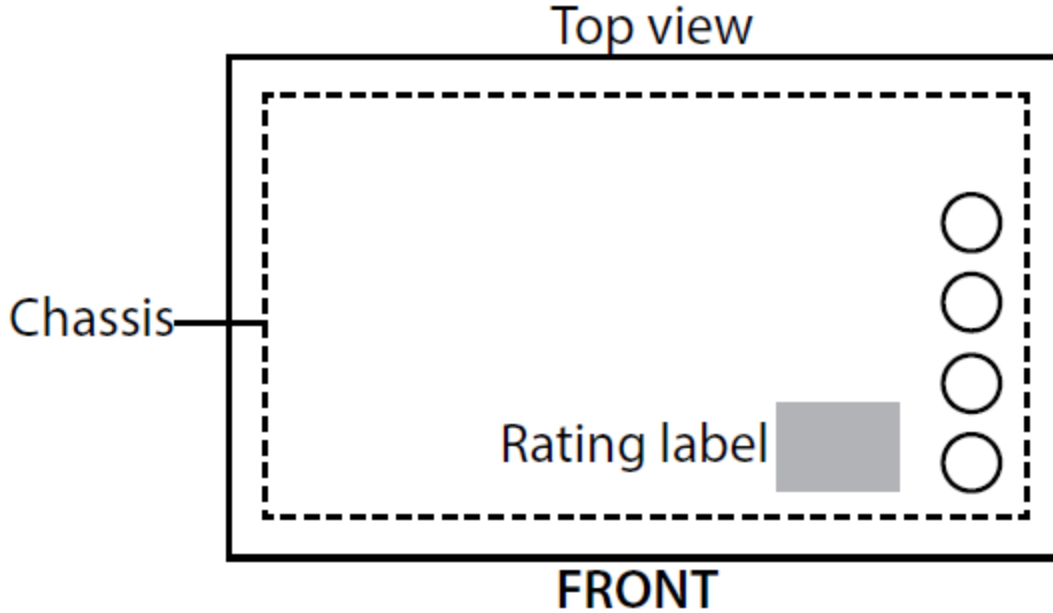

Required Grounding Method

This appliance is factory equipped with a power supply cord with a three-prong grounding plug (with polarized parallel blades) It must be plugged into a mating grounding-type receptacle, connected to a correctly polarized 120 Volt circuit. If the circuit does not have a grounding type receptacle, it is the responsibility and obligation of the installer or user to have the existing receptacle changed to a properly grounded and polarized receptacle in accordance with all applicable local codes and ordinances by a qualified electrician. In the absence of local codes and ordinances, the receptacle replacement shall be in accordance with the National Electrical Code.

THE THIRD GROUND PRONG SHOULD NOT, UNDER ANY CIRCUMSTANCES, BE CUT OR REMOVED. The electrical supply must be a 120 volt, 60 Hz single phase, 15 AMP circuit. The power receptacle must be a NEMA 5-15R device to accept the three prong plug supplied with the unit.

