

# DESIGN GUIDE FOR STRUCTURAL BRICK VENEER

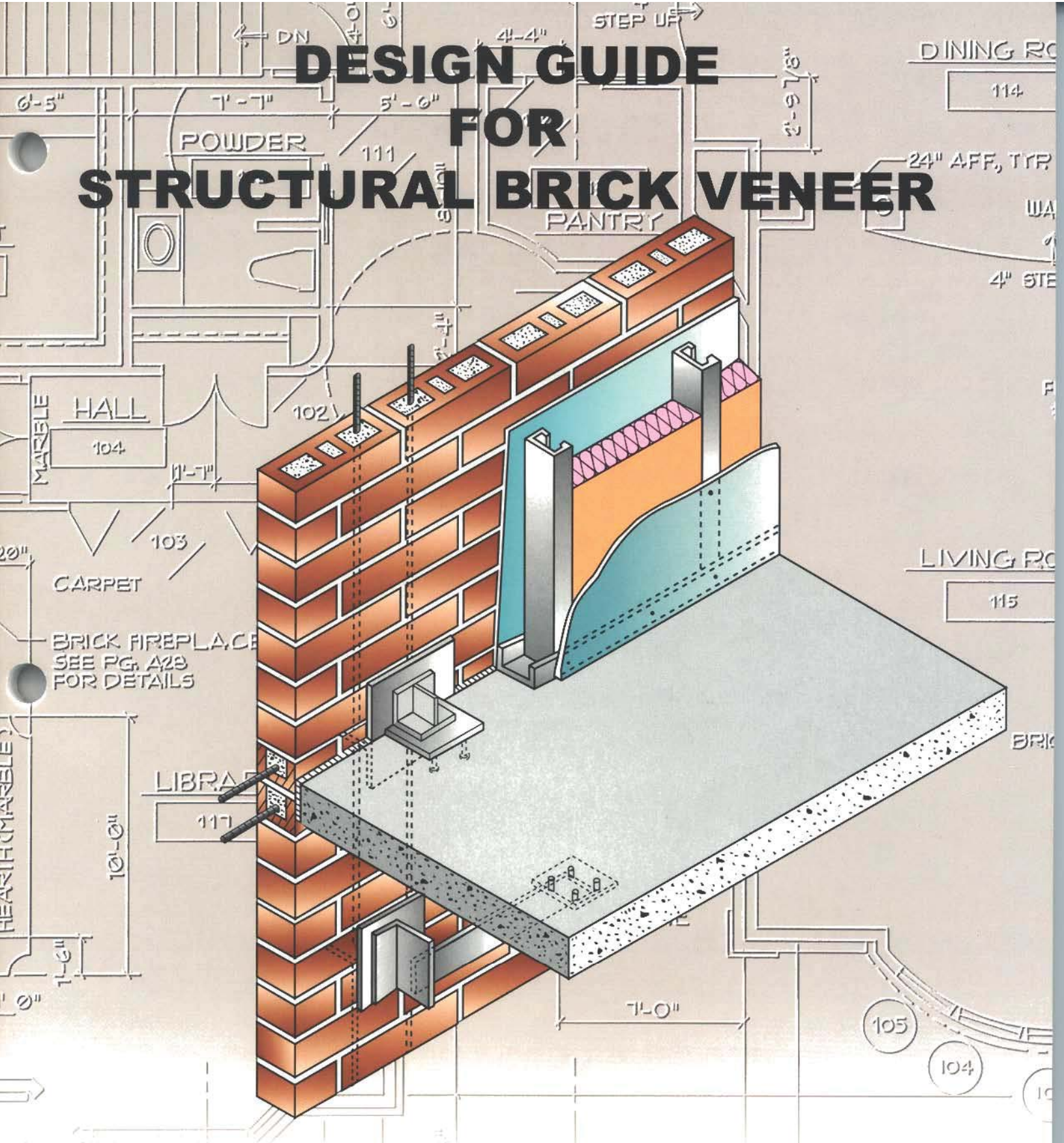

prepared for

**Western States Clay Products Association**

by

**KPFF Consulting Engineers**

**DESIGN GUIDE**

**FOR**

**STRUCTURAL BRICK VENEER**

Prepared for:

Western States Clay Products Association  
[www.wscpa.us](http://www.wscpa.us)

Submitted by:

KPFF Consulting Engineers  
1601 5<sup>th</sup> Ave. Suite 1600  
Seattle, WA 98101

Second Edition, July 2004

### *Acknowledgments*

The Design Guide for Structural Brick Veneer was sponsored by Western States Clay Products Association and written by KPFF Consulting Engineers. Principal-in-Charge for KPFF was John G. Tawresey. The preparation of the report was directed by the Technical Committee of the Western States Clay Products Association. The authors are appreciative of the help provided by Jim Anderegg, Mutual Materials Company, James Amrhein, Gregg Borchelt, Brick Institute of America, Jeff Elder, Interstate Brick Company and Don Wakefield.

John G. Tawresey, KPFF Consulting Engineers prepared the 2004 Second Edition.

The material presented in this publication, including technical and engineering data, figures, drawings and tables, is for general information only. It should not under any circumstances be relied upon for specific applications of the Structural Brick Veneer without independent evaluation by a licensed design professional familiar with its specific use and application. Anyone making use of this material does so at their own risk and assumes any and all liability resulting from such use.

Copyright 2004 by Western States Clay Products Association,

All rights reserved. No part of this publication may be reproduced, stored in a computer or retrieval system or transmitted in any form or by any means, electronic, mechanical, photocopy, fax, recording or otherwise, without the prior written consent of the author or Western States Clay Products Association.



### Summary

Structural Brick Veneer is a unique approach to the design and construction of brick exterior walls. Strengthening the brick with steel reinforcement provides new opportunities for reducing the cost of the wall, increasing design flexibility and improving wall performance. In use for more than thirty years, the approach has been used extensively in the Pacific Northwest.

The Structural Brick Veneer system is similar to conventional brick veneer except that the brick is reinforced to allow it to span further between ties and supports. The system allows the architect a variety of opportunities to create traditional walls or dramatic brick forms. Sloping windowsills, brick soffits, lintels without exposed ledger angles and precast concrete bands and inserts are only a few examples of the design opportunities available.

In areas of high seismic exposure, the Structural Brick Veneer system can be easily isolated from the primary structure making “immediate occupancy” performance more cost effective.

The following document will provide the structural engineer and the architect with an introduction to the design and specification of the Structural Brick Veneer system. It includes some design examples and dialogue on our experiences with the system over the past 20 years.



## List of Figures

FIGURE 1 TYPICAL HOLLOW BRICK .....	8
FIGURE 2 TYPICAL STRUCTURAL BRICK VENEER CONNECTOR.....	8
FIGURE 3 BRICK SUPPORTED ON A LEDGER.....	8
FIGURE 4 TYPICAL STRUCTURAL BRICK VENEER DEADLOAD CONNECTOR.....	8
FIGURE 5 DEAD LOAD ON THE FOUNDATION.....	9
FIGURE 6 FLEXIBLE CONNECTORS.....	9
FIGURE 7 SLOPING SILL BRICK SOFFITS .....	10
FIGURE 8 BRICK SOFFIT .....	10
FIGURE 9 PRECAST IN STRUCTURAL BRICK VENEER .....	11
FIGURE 10 BRICK EXPANDING RESISTED BY THE REINFORCEMENT .....	12
FIGURE 11 CRACKED BRICK.....	17
FIGURE 12 DIFFERENTIAL VERTICAL DEFLECTION.....	18
FIGURE 13 HORIZONTAL DRIFT JOINT .....	18
FIGURE 14 CORNER CONNECTED TO THE STRUCTURE.....	19
FIGURE 15 CORNER NOT CONNECTED TO THE STRUCTURE.....	19
FIGURE 16 HOSPITAL - PROJECT 1 .....	21
FIGURE 17 PROJECT 1 – PIER CONCEPT BETWEEN WINDOWS .....	22
FIGURE 18 LATERAL CONNECTION.....	22
FIGURE 19 DRIFT JOINT BEFORE LEDGER INSTALLATION .....	23
FIGURE 20 LEDGER INSTALLATION .....	23
FIGURE 21 PROJECT 2.....	23
FIGURE 22 HOSPITAL WITH MANY CORNERS .....	24
FIGURE 23 TEMPORARY RIGID FOAM BOARD SUPPORT .....	24
FIGURE 24 CONSTRUCTION SEQUENCE.....	25
FIGURE 25 BUILDING WITH ANTICIPATED DIFFERENTIAL SETTLEMENT.....	25
FIGURE 26 CONCEPT FOR SETTLEMENT .....	26
FIGURE 27 STIFFNESS OF BRICK MASONRY.....	27
FIGURE 28 STRIP SYSTEM EXAMPLE .....	29
FIGURE 29 SUPPORT FOR THE WALL .....	29
FIGURE 30 BRICK USED IN THE EXAMPLE .....	30
FIGURE 31 PLAN VIEW OF CONNECTOR.....	32
FIGURE 32 SIMPLE LATERAL CONNECTOR .....	34
FIGURE 33 FINAL DESIGN.....	36
FIGURE 34 LOCATION OF CONNECTORS .....	36
FIGURE 35 PLAN VIEW OF CONNECTOR.....	37
FIGURE 36 DEAD LOAD CONNECTOR .....	38
FIGURE 37 DEAD LOAD MOMENT .....	38
FIGURE 38 RESISTING MOMENT .....	39
FIGURE 39 WARPING CORNER.....	41
FIGURE 40 FLUID GROUT .....	43
FIGURE 41 PROTRUDING FLASHING DETAIL.....	45
FIGURE 42 FLUSH FLASHING DETAIL .....	45
FIGURE 43 VARIATION OF FIELD MORTAR TESTS .....	54
FIGURE 44 MORTAR 7 DAY AND 28 DAY TESTS .....	54
FIGURE 45 VARIATION OF FIELD GROUT TESTS .....	54
FIGURE 46 SEVEN DAY AND 28 DAY GROUT STRENGTH.....	55

**List of Figures ..... 4**

**1.0 Introduction ..... 6**

    1.1 Purpose & Scope..... 6

    1.2 History of the System..... 6

**2.0 System Description ..... 7**

    2.1 Structural Concept..... 7

    2.2 Concept Configurations ..... 9

    2.3 Weather Protection ..... 11

**3.0 Design..... 12**

    3.1 Who Designs the Wall? ..... 12

    3.2 Design Criteria ..... 13

    3.3 Designing the Wall ..... 21

    3.4 Design Examples ..... 29

**4.0 Specification ..... 42**

    4.1 Quality Control and Assurance..... 42

    4.2 Masonry ..... 43

    4.3 Steel for Connectors ..... 44

    4.4 Flashing/Weeps ..... 44

    4.5 Sealants ..... 45

    4.6 Water Repellents..... 45

    4.7 Backup Wall ..... 47

    4.8 Cavity ..... 47

    4.9 Expansion Joints ..... 47

    4.10 Window Anchorage..... 48

**5.0 Construction ..... 48**

    5.1 General..... 48

    5.2 Construction Sequence ..... 49

    5.3 Pre-Construction ..... 49

    5.4 Submittal Review..... 51

    5.5 Site Visits..... 52

    5.6 Non-Conforming Quality Control Tests..... 53

    5.7 Troubleshooting During Construction ..... 56

**6.0 Testing ..... 60**

    6.1 Air..... 60

    6.2 Water ..... 60

    6.3 Structural..... 60

### 1.0 Introduction

Structural Brick Veneer is the name that we have chosen to describe hollow reinforced clay brick curtainwall systems. These systems commonly replace brick veneer walls.

The Structural Brick Veneer system is similar to conventional brick veneer because it supports no gravity loads other than its own weight, the weight of windows, and possibly other miscellaneous loads. The difference is that in the Structural Brick Veneer system the masonry is reinforced to allow the brick to span further between ties and provide structural capacity to create more intricately shaped walls.

Structural Brick Veneer can be laid in place similar to conventional brick veneer, or they can be prefabricated at another location and lifted and installed to their final position.

The system has many advantages over conventional brick veneer. Some of these advantages are:

1. Greater design flexibility.
2. Reduced backup requirements.
3. Enhanced design life through heavier connections.
4. Reduced tie connections, which provides more continuous moisture barrier.
5. Greater seismic resistance and more ductility.
6. Less restrictive deflection requirements of the backup structure.
7. Reduced cost of the backup system.
8. Often lower construction cost.

9. Greater resistance to cracking.
10. Greater water resistance.

The system has been used on more than 100 projects over the last 20 years.

### 1.1 Purpose & Scope

The purpose of this guide is to provide the architect, structural engineer and owner with information about the design and construction of Structural Brick Veneers. It is intended to be easily understood by someone experienced with reinforced brick masonry design and construction. For those not familiar with the design of reinforced brick masonry, the Western States Clay Products Publication, "*Notes on the Selection, Design and Construction of Reinforced Hollow Clay Masonry*" is recommended.

As the design and construction of reinforced brick masonry varies from location to location, so does the design and construction of Structural Brick Veneer vary from location to location. The information and recommendations in this guide are based on the design and construction of projects in the Pacific Northwest and are not intended to replace local experience and engineering judgment.

### 1.2 History of the System

The origin of Structural Brick Veneer dates back to the early sixties. In 1962, a mechanical equipment penthouse was built on top of the nine-story United Fund office building in Denver, Colorado. The 15-foot high, load

bearing, 4-inch thick clay brick prefabricated panels supported long span, prestressed, twin-tee concrete slabs that were the roof structure of the penthouse. This construction was made possible by the use of a new "tensile strength intensive" exotic mortar and some backup steel reinforcing.

This 4-inch brick and exotic mortar system was used for several years thereafter in the Colorado area in prefabricated and in situ, hand-laid brick panel and curtainwall applications on many commercial buildings designed by George Hanson, P.E. of the firm of Sallada & Hanson, Engineers. This strong thin-wall system intrigued the designers who used this system on horizontal soffits, cantilevered balcony railings, post-tensioned panels, load-bearing and non-load-bearing walls on schools, office buildings, hospitals, the walls in vehicular tunnels, highway rest area toilet modules and picnic shelters. Even though this brick curtainwall system was very successful, it was relatively expensive due to the use of the high tensile strength mortar.

In the middle 1960's, Donald A. Wakefield, P.E. of the Structural Clay Products Institute developed, in Colorado, a new clay unit and method of construction that reduced the cost and allowed for the use of regular reinforcing and standard mortar and grout. This unit was a 3-1/2" x 3-1/2" x 11-1/2" hollow clay brick using ASTM C-212 recommendations. This system accommodated both horizontal and vertical reinforcing and permitted high-lift grouting.

This thinner reinforceable, hollow clay unit was more economical, ductile, flexible and more predictable; thus expanding its use in commercial curtainwall systems as well as load-bearing residences, four-story load-bearing apartment buildings, and prefabricated panels.

During the 1970's, a similar system was developed and perfected by Barkshire Panel Systems, Seattle, WA. Barkshire's system used a 3 1/2-inch thick hollow clay brick similar to the one mentioned earlier and verified by testing conducted by Western States Clay Products Association under the direction of John G. Tawresey.

The secret to Barkshire's system was advancements in the connections to the frame, and the technical knowledge of the overall building's physical needs.

As a consequence, the system is found on multi-story high-rise office buildings, schools, apartment buildings, residences and many other applications throughout the Northwest.

## **2.0 System Description**

The system relies on a simple structural concept that will be described, followed by the presentation of some typical configurations and a brief discussion of weather protection.

### **2.1 Structural Concept**

Structural Brick Veneer is essentially the same as conventional brick veneers except that the brick is reinforced. Hollow bricks that can be reinforced are a necessary part of the system.



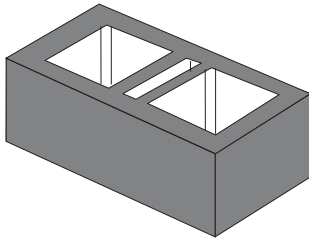

Figure 1 Typical Hollow Brick

The reinforcement increases the structural capacity of the brick wall. The spacing of the ties, typical in conventional veneers, can be increased and in most cases, the spacing can be increased to the distance between building floors or columns. The conventional veneer ties are eliminated and are replaced by more substantial connectors. The connectors are usually attached to the primary structural system of the building instead of a separate backup wall.

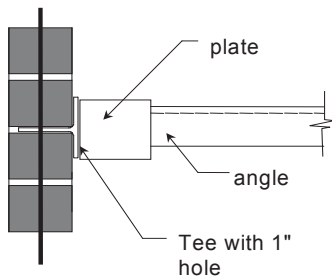

Figure 2 Typical Structural Brick Veneer Connector

Ledgers very similar to the ledgers of more conventional veneers can support

the dead load of the Structural Brick Veneer.



Figure 3 Brick Supported on a Ledger

Or, separate discontinuous connectors can be used to support the dead load. These connectors are similar in design to those used to support precast concrete panels.

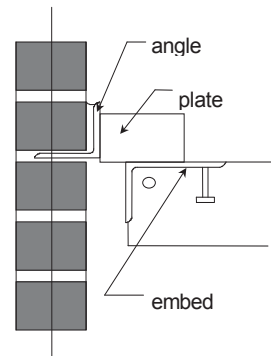

Figure 4 Typical Structural Brick Veneer Deadload Connector

Another available option is to support the dead load of the Structural Brick Veneer on the building foundation. Because the Structural Brick Veneer is designed in accordance with the

structural chapters of the code, height limitations are generally more liberal.

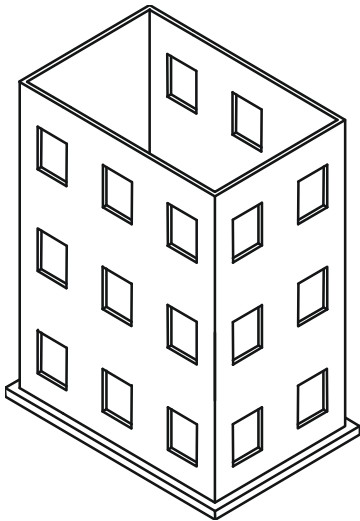

Figure 5 Dead Load on the Foundation

The connectors of the Structural Brick Veneer are designed and constructed to be flexible in one or more directions and rigid in other directions. Thus, the Structural Brick Veneer can be isolated from the movements of the building.

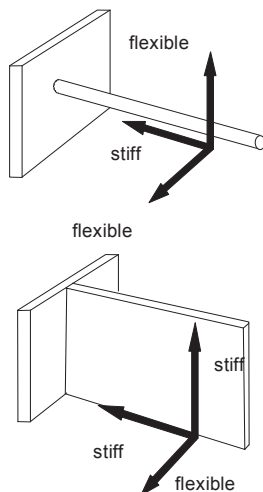

Figure 6 Flexible Connectors

The design of the Structural Brick Veneer is based on the following principles:

1. The Structural Brick Veneer is designed to be isolated from the primary building structure. For non-essential facilities, the isolation should be adequate to insure that the brick will not be damaged by a moderate earthquake. For essential facilities, the isolation should be adequate to insure that the brick will not be damaged by a maximum considered earthquake. The Structural Brick Veneer must not support the building or provide any assistance to the stability of the building as a whole.
2. Structural Brick Veneer is commonly designed to have **mortar joint** cracks at service wind and seismic loading. However, **brick cracking** should not occur. Cracking should be limited to the cracking of the horizontal bed joints at the brick to mortar interface. This is an aesthetic design criteria rather than a structural performance criteria. Experience has shown that cracking of the brick unit is considered by most owners to be a failure of the system.
3. The Structural Brick Veneer is designed to transfer the loading to the connectors and the connectors are designed to transfer the loading to the primary structure.

### 2.2 Concept Configurations

Structural Brick Veneer buildings can be configured in limitless ways. Because the brick wall has more capacity to resist

loading, the designer has more choices to configure and attach the wall. The number of different forms is controlled only by the designer's imagination.

The Structural Brick Veneer system offers the architect a variety of opportunities to create dramatic brick forms. Sloping windowsills, brick soffits, lintels without exposed ledger angles and precast concrete bands are only a few examples.

### Sloping Sills

Sloped sills are a common accent in brick construction. Small slopes created from special brick shapes can be readily incorporated into the Structural Brick Veneer wall. Larger, more dramatically sloped sills may require shoring to construct.

Where the depth of the slope does not allow the weight of the brick veneer to cantilever from the vertical wall, then adding connections or spanning horizontally to column supports can provide alternative support.

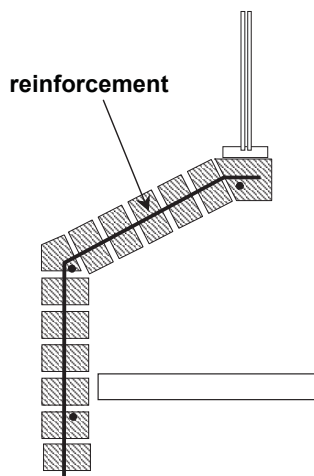

Figure 7 Sloping Sill Brick Soffits

Brick soffits can be designed and constructed similar to the conditions at a sloping sill.

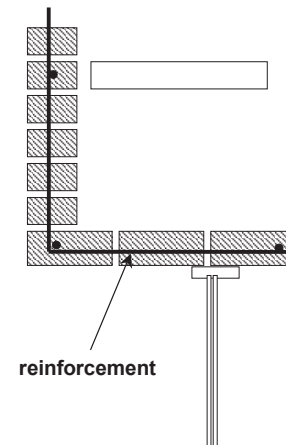

Figure 8 Brick Soffit

### Brick with Concrete Masonry

Another architectural variation is to combine concrete masonry with Structural Brick Veneer. This commonly takes the form of banding, either horizontal or vertical, or as an accent pattern. In some circumstances, concrete masonry may be used instead of brick where it doesn't show. In either arrangement, concrete masonry can be incorporated into the Structural Brick Veneer with ease. The designer should recognize however that the spacing of reinforcement in brick might not match the cells in the concrete masonry. Some effort should be made to space the reinforcement to match both modules. Also, when using horizontal brick and concrete masonry bands, the designers must recognize the opposing behavior and strengths of the two materials and detail accordingly with movement joints and reinforcement. Brick will expand with exposure to moisture while concrete masonry is more dynamic and

will shrink with drying and expand with moisture. Extra reinforcement may be added to reduce the impact of this effect.

### Brick with Precast Concrete

Precast concrete window sills and heads as well as accents can be successfully included in a Structural Brick Veneer System. Where the precast elements are small, they can be added by providing holes through the precast for the reinforcement. Large precast components may require separate connectors to the building frame or to the Structural Brick Vener.

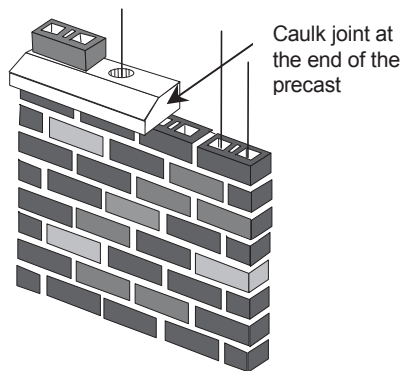

Figure 9 Precast in Structural Brick Veneer

Also, precast concrete elements shrink with time and drying, and expand with moisture. Again, the designer should consider the compatibility of the expanding brick and shrinking concrete.

### 2.3 Weather Protection

The primary function of the exterior wall is to protect the interior of the building from the weather.

The Structural Brick Veneer System provides two methods of weather protection. The exterior brick veneer, caulking, and windows act as the primary barrier. The interior cavity, flashing, weeps, window channels and other elements act as the secondary barrier.

The system performance depends to a large extent on the prevention of water leakage through the reinforced brick. Reinforced brick is more water-resistant than unreinforced brick. The most obvious reason is that the cracks are smaller and more evenly distributed due to the resistance provided by the reinforcement.

Another reason is that brick expands with age. When the brick is made, it contains no water. With time, the brick absorbs water and reaches equilibrium with its moist environment. The clay expands (just like unfired clay). The moisture can come from the humidity in the air. This expansion can take years.

ACI 530-02/ASCE 5-02/TMS 402-02 *Building Code Requirements for Masonry Structures* recommends a value of .0003 inch/inch for moisture expansion of clay masonry.

When the brick expands, the reinforcement tends to resist the expansion. The reinforcement is stretched in tension and the brick masonry compressed. The consequence is smaller and sometimes there are fewer cracks.



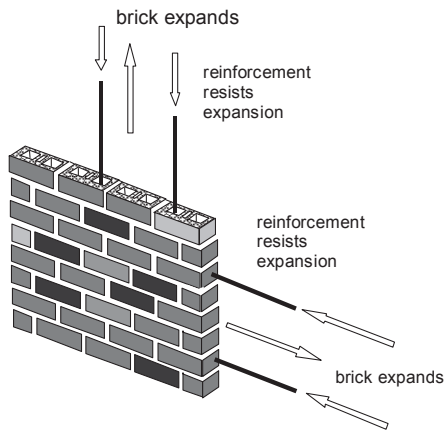

Figure 10 Brick Expanding Resisted by the Reinforcement

Even with smaller cracks, leakage can still occur. Wind-driven water flows in sheets in all directions over the wall and concentrates at discontinuities such as joints. Lateral movement of water is greatest near the windward corners. Movement upward is greatest near the top of the building. Tall buildings have greater accumulation of water flow. Greater distances between irregularities will result in larger flows.

It should be assumed that all masonry might leak and allow water to penetrate. Masonry leaks more through the mortar and brick interface than through the masonry unit itself. If the mortar and brick interface is cracked, leakage may increase.

There are two concepts used to control the water. The first is the drainage wall, and the second is the “rainscreen” principle.

A drainage wall consists of a secondary method of removing the moisture once it

has penetrated the outside wall. Flashing is an example.

The principle of the rainscreen consists of providing a cavity behind the wall that equalizes the outside pressure thus preventing the water from penetrating the outside surface. A properly proportioned rainscreen wall needs no caulk on the outside barrier. Unfortunately, the available technology for designing rainscreen walls is limited and while many walls use some of the principles, most installations rely on a drainage wall system. For more information on the rainscreen walls, see Western States Clay Products publication “*Design Guide for Anchored Brick Veneer Over Steel Studs*”.

### 3.0 Design

Once the decision to use Structural Brick Veneer is made, the next step is to provide for a design. The Structural Brick Veneer is not part of the primary structural system and, consequently, may, or may not be designed by the building design team. It may not be in their scope of services. Thus the first issue to address is who designs the wall? Whether designed by the building design team or by a designer working for the contractor or sub-contractor, the design criteria and methods of analysis are the same. In the next paragraphs, these methods are described followed by three design examples.

#### 3.1 Who Designs the Wall?

Structural Brick Veneer, like other wall systems, can be designed by either the design team and bid, or it can be specified as a bidder-designed item. It is done both ways.

Some owners complain to their architect that the design is incomplete without drawings and specifications to bid the exterior wall. It is like “buying a car without the wheels.” Yet, contractors design most exterior walls because they have special knowledge necessary to complete the task.

Questions that should be addressed early in the design of any wall system include the following. How much of the design of the wall should be shown on the design drawings? Where does the designer of record’s responsibilities end and the contractor’s responsibilities begin?

Often, the structural engineer of record does not show bracing because he is unaware of the wall system to be used and the method of attachment is left to the contractor. The designer should clearly identify on the drawings the responsibility for the design and construction of each component of the wall system, including bracing.

In some locations, it is common for brick veneer supports to be shown on the design drawings. In Seattle, it is common for the structural engineer of record to design precast concrete panels as part of the “standard services”. In most locations, including Seattle, the contractor prepares the design of Structural Brick Veneer.

These examples are presented to illustrate that there is no consensus about who should design an exterior wall. The “*National Practice Guidelines for the Structural Engineer of Record*” published by the Council of American Structural Engineers clearly states that

the design of curtainwall systems is not considered part of Basic Services. It is considered Additional Services under Special Services. Unfortunately, the document does not provide us with help for the bracing and stiffening problem. Nor does it show where to draw the line of responsibility between the contractor and the structural engineer of record.

No matter who designs the wall, the contractor or the engineer of record, the following information about the design criteria and methods applies.

### **3.2 Design Criteria**

The design criteria for Structural Brick Veneer includes the applicable code sections, the appropriate design life, seismic performance, loads, allowable stresses, code prescriptive requirements and special connection requirements.

#### **3.2.1 The Applicable Code Sections**

The term “Structural Brick Veneer” may cause some confusion when applying the building code. The use of the term “Veneer” implies “non-structural”. However, the structural analysis of the Structural Brick Veneer uses the structural portions of the masonry design codes. But, they are used in combination with the performance criteria of the masonry veneer sections of the code.

#### **3.2.2 Design Life**

Design life is an important quantitative measure that defines the quality of the project. Buildings will not last forever. The owner and designer should establish a reasonable design life for each project. This requires consideration of

the economic factors such as initial cost and maintenance costs. The design life will have an impact on the selection of materials, maintenance procedures, and the selected factors of safety.

The expected performance is also an important qualitative measure for the design of the project. The minimum performance level is set by the building code, however, there are aspects of a Structural Brick Veneer System performance that are not explicitly covered by the code and require judgment.

It has been useful to define two distinct levels of expected life and performance:

Level 1 (institutional) is intended to signify a high level of quality and long life. Buildings of this type might include public or institutional buildings. Specifically, these are buildings where the additional costs associated with higher quality are judged to be necessary in meeting the overall project requirements.

Level 2 (commercial) is intended to signify a good level of quality and an average design life. Buildings of this type might include general office, industrial, and residential buildings. These are buildings where the additional cost of Level 1 (institutional) quality is not economically justified or necessary.

Increasing the quality of the connectors, improving the weather resistance of the materials and expanding on the amount of inspection and testing are the normal means to increase the design life.

### 3.2.3 Seismic Performance

Seismic performance of Structural Brick Veneer is a complex subject since under certain levels of seismic shaking, damage can occur to the veneer. There are currently several organizations preparing standards for seismic design. The National Earthquake Hazards Reduction Program (NEHRP-2000) divides the performance of structures into four levels:

1. Operational: "Structures meeting this level when responding to an earthquake are expected to experience only negligible damage to their structural systems and minor damage to nonstructural systems" (the structural brick veneer). "Repairs if necessary can be conducted at the convenience of the owner." "The risk to life is negligible."
2. Immediate occupancy: "Structures meeting this level are expected to sustain more damage to nonstructural systems" (the structural brick veneer). "Exterior nonstructural wall elements and roof elements continue to provide a weather barrier, and are otherwise serviceable" (although they may be damaged).
3. Life safety: "Significant structural and nonstructural damage has occurred." "Nonstructural elements of the structure, while secured and not presenting falling hazards, are severely damaged and can not function" (the structural brick veneer).
4. Collapse prevention: "The structure has sustained nearly complete damage. Nonstructural elements of the structure have experienced substantial damage and may have become dislodged creating falling hazards" (the structural brick veneer).

The NEHRP provisions also distinguish between building uses by assigning each structure a Seismic Use Group.

1. Group III are essential facilities requiring post-earthquake use.
2. Group II are facilities with a large number of occupants.
3. Group I are all other facilities.

Combining the performance classification with the occupancy distinction results in the following chart describing expected seismic performance.

	Operational	Immediate Occupancy	Life Safety	Near Collapse
Frequent Earthquakes (50% in 50 years)				
Design Earthquake (2/3 of MCE)				
Maximum Considered Earthquake (2% in 50 years)				

The chart is a 3x4 grid. The columns are labeled 'Operational', 'Immediate Occupancy', 'Life Safety', and 'Near Collapse'. The rows are labeled 'Frequent Earthquakes (50% in 50 years)', 'Design Earthquake (2/3 of MCE)', and 'Maximum Considered Earthquake (2% in 50 years)'. Three diagonal lines represent performance levels for different building groups:
 

- Group I buildings:** A line starting from the top-left cell (Operational, Frequent) and ending at the bottom-right cell (Near Collapse, Maximum Considered).
- Group II buildings:** A line starting from the top-left cell (Operational, Frequent) and ending at the bottom-right cell (Life Safety, Maximum Considered).
- Group III buildings:** A line starting from the top-left cell (Operational, Frequent) and ending at the bottom-right cell (Immediate Occupancy, Maximum Considered).

The building code is not specific about the seismic performance of curtainwall and Structural Brick Veneer. Judgment is required on the part of the engineer to develop appropriate seismic criteria based on the project performance objective. For example, failure of a Structural Brick Veneer over the firehouse door during a major earthquake is not acceptable. Whereas, complete separation of a Structural Brick Veneer from the frame on a suburban office building with surrounding planters may be acceptable.

Because of the nature of the connections, Structural Brick Veneer can be designed to perform to a higher seismic performance level than conventional veneer. For buildings with operational performance or immediate occupancy

criteria, Structural Brick Veneer offers significant advantages. If high seismic performance criteria are combined with a complex geometry, sills, soffits and articulated surfaces, it is likely that Structural Brick Veneer will be the least costly system.

### 3.2.4 Design Loads

Loads applied to a Structural Brick Veneer include dead load, wind load, and seismic load. The Structural Brick Veneer should support no vertical load other than its own weight. In normal practice, it may also support the weight of window systems, small air handling units and possibly some ornamentation.

Most modern building codes contain two levels of loading, service loads (allowable stress design) and ultimate loads (strength design). Both levels of loading are used in the design of Structural Brick Veneer. Local jurisdictions must be consulted for the correct design load criteria.

### 3.2.5 Design Assumptions and Allowable Stresses

#### Working Stress Design

Working stress design methods are recommended. Strength or limit states design methods are still in the development stage and have not been extensively used for the design of structural brick or Structural Brick Veneer. The ACI 530-02/ASCE 5-02/TMS 402-02 *Building Code Requirements for Masonry Structures* contains a new strength design section, Chapter 3. It may offer less conservative designs for Structural Brick Veneers resisting out-of-plane



wind and seismic loading particularly when compared to allowable stress design that does not allow a one-third increase in allowable stress for load combinations, including wind or seismic loading.

### Allowable Stresses

The allowable stresses permitted in the Structural Brick Veneer are the same as those allowed for structural reinforced masonry. The one-third increase in allowable stress is typically used for load combinations, including wind and seismic loads.

The design of connectors requires additional allowable stresses not typically included in the building codes. These additional required allowables are as follows:

1. The shear cone capacity of masonry for pull-out is typically taken as the beam allowable shear stress ( $1.0 \times (f'_m)^{1/2} \leq 50$  psi).
2. The shear cone angle is conservatively assumed to be 20 degrees instead of the more commonly used 45 degrees.
3. The torsion allowable stresses are assumed equal to the beam shear allowable stress ( $1.0 \times (f'_m)^{1/2} \leq 50$  psi). Unpublished testing on several projects has confirmed the validity of this assumption for several projects. The tests consisted of square panels fixed on three corners and lifted on the fourth corner. Failure stresses were typically 2.5 times the allowable values.
4. The concrete shear friction equation is assumed to apply with a friction factor of 0.4, ( $A_v = V_u / \phi F_y$ ). The ultimate shear is taken as 2.0 times the design shear.
5. The tension allowable stress of the brick mortar interface is typically neglected.
6. The tensile capacity of the brick is assumed to be 10% of the compression capacity. The allowable stress is determined by applying an appropriate factor of safety for the load condition being considered. This allowable is for the brick, not the masonry. The code provides allowable tension values for the masonry in tension parallel and perpendicular to the bed joints and for different bonding patterns and mortars.
7. The allowable bond stress to plane steel is assumed to be 60 psi. or the same value as the allowable bond stress to plane bars.

### Cracking of Brick

At service loads, the brick units should not crack. Cracking of the interface between the brick and mortar is acceptable. However, a cracked brick could be an aesthetic problem even though the structural capacity may be adequate. The engineer should decide the appropriate service design loading and the factor of safety to be applied.

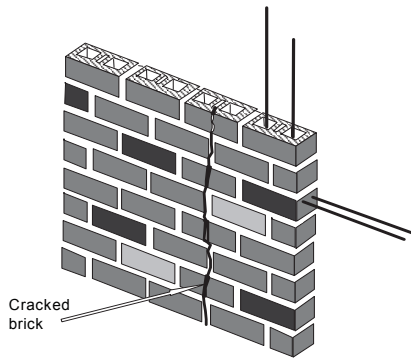

Figure 11 Cracked Brick

### Code Minimum Requirements

It could be interpreted that because the Structural Brick Veneer is not classified as structural in the code, the prescriptive minimums of most structural codes do not apply. An example is that the usual minimum reinforcement spacing does not apply. However, the practice is to conform to these minimum requirements as though the Structural Brick Veneer is structural reinforced masonry.

### Connector Requirements

Most seismic codes have special minimum criteria for the design of curtainwall connections. These provisions are principally directed towards precast concrete panels used as curtain wall and it is reasonable to assume they apply to Structural Brick Veneer.

One example is IBC 2003 Chapter 16, Section 1621 which references ASCE 7 (2002) Section 9.6.2.4:

1. Connection and panel joints shall allow for the story drift caused by relative seismic displacements ( $D_p$ ) determined in Section 9.6.1.4, or  $\frac{1}{2}$  in. whichever is greatest.

2. Connections to permit movement in the plane of the panel for story drift shall be sliding connections using slotted or oversize holes, connections that permit movement by bending of steel, and other connections providing equivalent sliding and ductility capacity.

3. The connecting member itself shall have sufficient ductility and rotation capacity so as to preclude fracture of the concrete (masonry) or brittle failures at or near welds.

4. All fasteners in the connecting system such as bolts, inserts, welds and dowels and the body of the connectors shall be designed for the force ( $F_p$ ) determined by Eq. 9.6.1.3-2 with values of  $R_p$  and  $a_p$  taken from Table 9.6.2.2 applied at the center of mass of the panel.

5. Anchorage using flat straps embedded in concrete or masonry shall be attached to or hooked around reinforcing steel or otherwise terminated so as to effectively transfer forces to the reinforcing steel or to assure that pullout of anchorage is not the initial failure mechanism.

### 3.2.5 Isolation from the Building

The most challenging part of the design is to isolate the Structural Brick Veneer from the building frame. There are many ways that this can be accomplished and a few will be discussed.

The amount of isolation is an important factor and the code does not provide precise criteria. There are three directions in space: vertical, horizontal in the plane of the wall, and horizontal perpendicular to the plane of the wall. The building behind

the wall, while seemingly static, is in fact subject to a variety of different movements in all three directions.

### Vertical Isolation

The vertical movement can result from several different sources. The following figure shows one source.

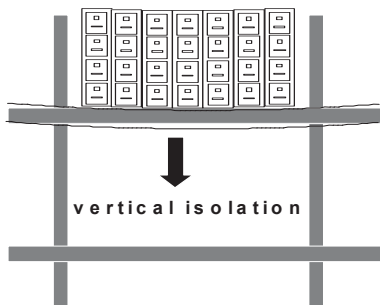

Figure 12 Differential Vertical Deflection

The different amount of vertical loading on the floors will result in a shortening of the distance between the floors. In many buildings, this can be an important factor and can result in differential deflections of greater than three-quarters of an inch. If the system does not provide compliance for this movement, the file cabinet load will be reacted by the Structural Brick Veneer instead of the floor beams and could cause failure.

If the building is constructed of concrete, the concrete shrinkage and creep will contribute to the shortening between floors. In high-rise construction, the elastic and differential elastic shortening may become important and may affect the construction schedule and sequencing.

### Horizontal Isolation in the Plane of the Wall

Lateral forces from wind and seismic loading cause horizontal movement of the building frame. When one floor moves horizontally relative to the adjacent (higher or lower) floor, the wall system must accommodate the movement. If the Structural Brick Veneer is attached to both floors, then the veneer would resist the lateral forces and possibly fail. The amount of differential horizontal movement can be large; up to four inches is common in areas of high seismic activity.

A movement joint at the window head is commonly used to accommodate the horizontal movement.

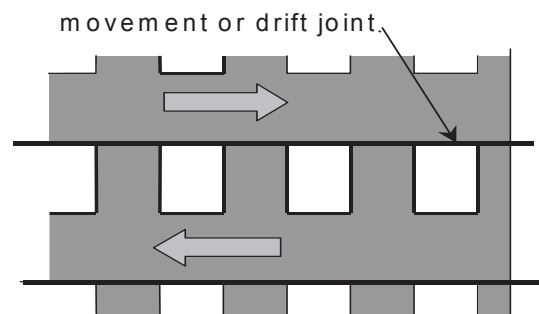

Figure 13 Horizontal Drift Joint

These joints are usually called drift joints and can be located at any horizontal plane of the building. When horizontal joints change elevation at different surfaces of the wall, it is difficult to accommodate horizontal displacement.

This concept is simple until the joint reaches the corner. Corners provide additional natural restraint, and can result in an unwanted attachment to the frame.

The following figure shows an example of a Structural Brick Veneer where the connection to the structure near the corner was designed to be rigid for forces perpendicular to the wall.

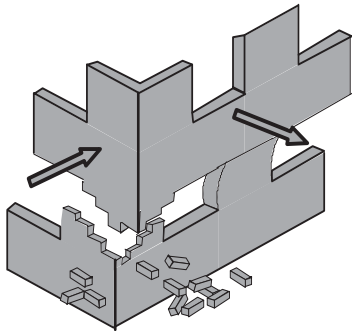

Figure 14 Corner Connected to the Structure

There are several methods available to provide isolation at a corner. One is to eliminate the corner connections and have the Structural Brick Veneer resist the loading.

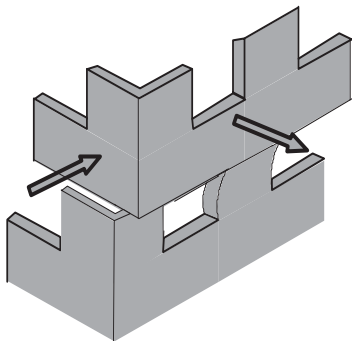

Figure 15 Corner Not Connected to the Structure

### Horizontal Isolation Perpendicular to the Plane of the Wall

Another is to accommodate the movement with warping of the corner panel. This will be shown in one of the examples to follow.

For walls away from corners, horizontal movements perpendicular to the plane of the wall are accommodated by out-of-plane bending of the masonry. Typically, reinforced masonry has the capacity to accommodate large deflections in this direction and the isolation in this direction is seldom a design consideration.

### Typical Deflection Magnitudes

The amount of isolation required depends on loading and expected performance. There are no known accepted national standards, but as a guide, Table 1 presents typical values and code requirements for isolation.



**TYPICAL MOVEMENT DESIGN CRITERIA <sup>(1)</sup>**

Movement Type	Structural System	Source of Movement	Limitations	Recommended Values	Typical Values	Isolation Method
Vertical Floors	Steel or concrete	Differential application of live load	L/600	<0.60 inch	1/4"	Compensation channel at the window head
						Soft joint under the ledger angle
	Concrete	Shrinkage with drying	(2)	(3)	1/16"	Allow the concrete to dry and cure before installing the veneer
						Creep
Vertical Columns	Steel	Differential elastic shortening	(2)	(3)	(3)	Only applies to high-rise buildings where the veneer is installed prior to finishing the building frame
						Concrete
	Creep	(2)	(3)	1/16"	Compensation channel at the window head	
					Soft joint under the ledger angle	
Lateral	Frame of steel or concrete	Wind	(2)	.0025H	3/8"	Usually absorbed elastically in the system
		Seismic	Per analysis Minimum 1/2"	Depends on occupancy	2 1/2 TO 3"	Compensation channel at the window head
						Soft joint under the ledger angle
	Shear Wall	Wind	(2)	.0025H	1/8"	Usually absorbed elastically in the system
		Seismic	Per analysis Minimum 1/2"	Depends on occupancy	1/4 TO 1/2 "	Compensation channel at the window head
						Soft joint under the ledger angle

1. This table should not be used for design. Each project has unique requirements.
2. No known values.
3. Depends on the structure.

### 3.3 Designing the Wall

The discussion describing the design of a Structural Brick Veneer wall will be divided into four parts:

1. The layout or configuration.
2. The design of the wall for code prescribed loading.
3. The design of the wall to prevent cracking of the brick.
4. The design of the connections.

In the normal process of design, all four parts are accomplished at the same time. Following the four parts, several design examples demonstrating the methods will be presented.

#### 3.3.1 Layout or Configuration

Usually the designer begins with an architectural rendering of the wall elevations. The designer must decide on the method of isolation and the locations to react the dead load, wind and seismic loads applied to the wall.

It is difficult to describe the process for deciding the configuration of the veneer. It is part of the art of structural engineering and experience will help. Three example projects are presented to provide some insight into the issues. These represent complex applications of the Structural Brick Veneer configurations and were chosen to demonstrate the flexibility of the system. Simpler applications are more common.

#### Project 1

A hospital project was in the contract document phase of design. The architect's concept for the wall was brick veneer over metal studs. Unfortunately, the design had assumed only a 9-inch thickness for the wall: Three and one half inches of brick, a 1-1/2 inch cavity and 4" deep steel studs. The floor height was 14'-8"



Figure 16 Hospital - Project 1

When the project structural engineer was asked to size the steel studs, it became apparent that the 4" depth was insufficient to support the conventional veneer. Adding thickness to the exterior wall reduced building space and had a major impact on the already designed interiors and room layout. The design of the project stopped because of the problem.

Structural Brick Veneer provided a solution. However, a 4" reinforced brick wall could not span the 14'-8" as a simple span between floors. One option was to use a 5" or 6" brick to make a simple span between floors, but this did not leave enough depth for the interior studs

to support the wallboard without thickening the wall. The solution was to provide a 4" thick (specified thickness is 3.5") Structural Brick Veneer wall system supported as shown in the following Figure.

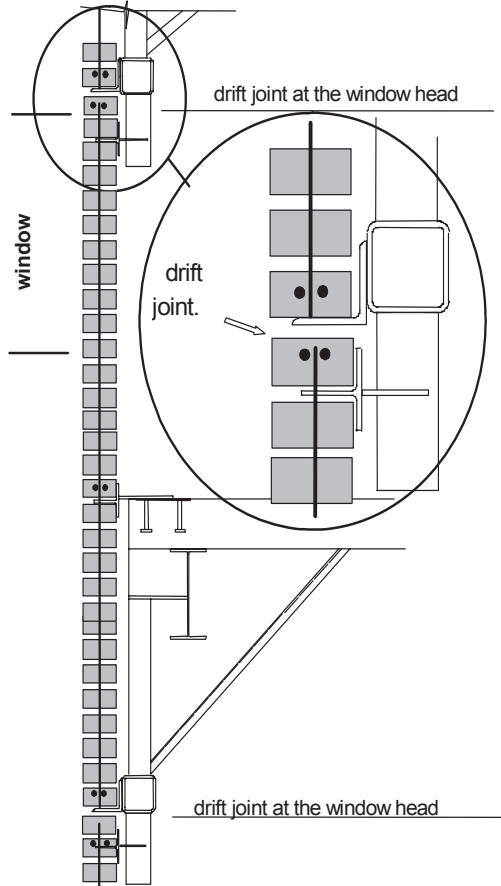

Figure 17 Project 1 – Pier Concept Between Windows

The brick masonry is supported on continuous angles located at the window head. These angles, or ledgers, are supported on a girt system suspended from hangers with kickers framing back to the underside of the slab.

Lateral bracing at the floor consists of galvanized 1/8-inch thick plate with holes for vertical reinforcement. This brace is flexible in the vertical direction and stiff in both horizontal directions.

The seismic or drift joint is located at the window head, below the ledger. The joint directly below the ledger is a caulk joint. Another lateral brace is located below the ledger. This brace is stiff perpendicular to the plane of the wall and flexible in both the horizontal in the plane of the wall and the vertical directions. This is accomplished by using a 1/8-inch thick galvanized plate with holes for the vertical reinforcement supported by two 1/8-inch thick galvanized plates welded to the bottom of the girt and welded to the plate into the brick.

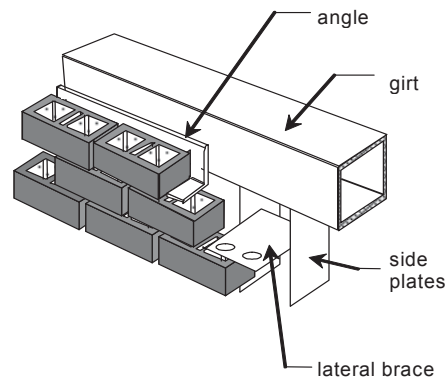

Figure 18 Lateral Connection

This configuration reduced the spans sufficiently to allow the 4" brick to resist the applied loading.

The stud wall was 26-gauge steel studs and was used only for the support of the water barrier and air barrier, and interior wallboard.

## STRUCTURAL BRICK VENEER



Figure 19 Drift Joint Before Ledger Installation

Dowels were welded to the ledgers, and the brick was laid by threading over the dowels. When the construction of masonry reached the head location, bars were dropped into the vertical cells and the wall solidly grouted.



Figure 20 Ledger Installation

The masonry units are nominal 4x4x12 inch with two 1-3/4 x 3-1/2 inch cells. The design  $f'_m$  was 4,000 psi .

### Project 2

The second project is also a hospital addition located in an area of high seismic risk. The hospital program and site generated a geometric shape consisting of several boxy wings. A brick wall was chosen to match the old building.

The boxy nature of the floor plan made isolation for seismic lateral displacements nearly impossible with conventional veneer construction. Structural Brick Veneer was chosen because of its ability to isolate the brick veneer from the building.



Figure 21 Project 2

This Structural Brick Veneer was designed to accommodate a large lateral

## STRUCTURAL BRICK VENEER

seismic displacement. The building structure was a steel moment frame in one direction and a steel braced frame in the other. Because of the many corners, an unconventional approach to the isolation was used. The concept was to build a Structural Brick Veneer box in the shape of the outside wall. The box was one floor tall extending several courses above the window at the next floor. The box was then attached to the building so that it moved with each floor. The dead load support was at the floor.

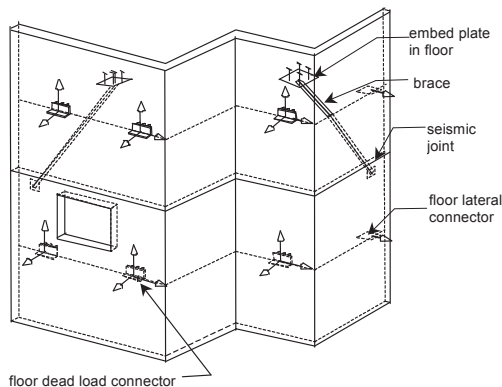

Figure 22 Hospital with Many Corners

The corners of the box resisted the wind and seismic loading perpendicular to the surfaces of the wall. The reaction of the wind and seismic load occurs in the dead load anchors as shear and overturning. Where corners were spaced too far apart to span between them, braces were added to the underside of the slab for the floor above at a sufficient distance from the corners to accommodate the differential horizontal movement of the floor by warping of the masonry.

When the building moves laterally, the rigid corners are unaffected and the

under-floor braces cause warping of the wall. The displacement perpendicular to the wall caused by the brace is at a sufficient distance from the corner to warp the wall without failure.

Continuous ledgers were not used in this situation because they would not provide adequate strength to resist the overturning forces. Consequently, the normal construction sequence needed to be modified.

The construction proceeded as follows: Beginning from the masonry below, rigid foam board was placed on the brick. Brick was then laid on top of the foam board for a height of two feet above the floor. This masonry engaged the dead load connector. At this time, the wall was grouted and allowed to cure for three days. Masonry was then laid to several courses above the window head and the process repeated for each floor. Caulk was placed over the face of the foam board that was left in the wall.

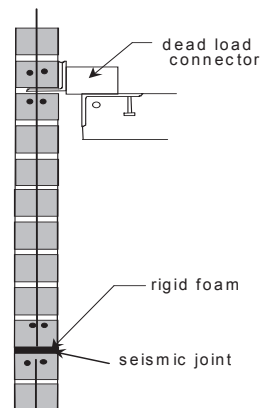

Figure 23 Temporary Rigid Foam Board Support



**Project 3**

A final example is a combination of laid-in-place Structural Brick Veneer and prefabricated Structural Brick Veneer or brick panels. Brick panels are similar to precast concrete panels except they are constructed of reinforced brick instead of reinforced concrete. The project was built on fill with friction piling used to support the load. The foundation design was such that 1/2 inch of differential settlement was expected in 50 feet. The building frame was a combination of steel and wood. The corners could be damaged in a moderate earthquake. The typical wall elevation is shown in the following Figure 25.

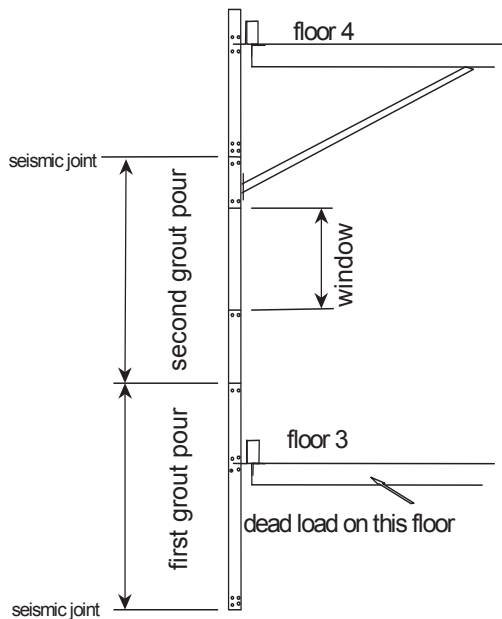

Figure 24 Construction Sequence

The design used isolated connectors instead of a ledger because, under lateral load conditions, the wall produced uplift on the floor and it was felt that the best design was to provide specific points for these forces to be reacted. The corners provide much of the needed lateral bracing, thus the number of connectors to the structure is relatively few.

The brick was a 5-inch unit. Custom shapes were provided. Additionally, the project used prefabricated Structural Brick Veneer (brick panels) where scaffolding was difficult to install or where the support of the brick was not available.

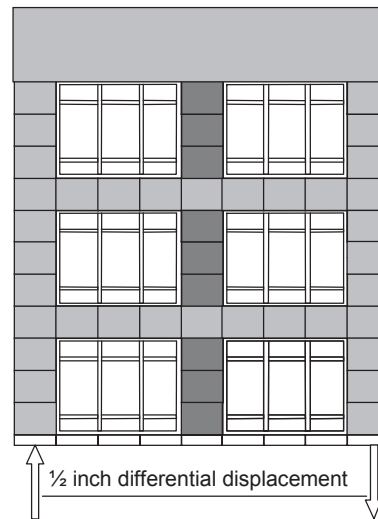

Figure 25 Building with Anticipated Differential Settlement

The solution was to use Structural Brick Veneer column elements with the dead load supported at the foundation. Lateral bracing was provided at each floor. Brick

panels were hung off the Structural Brick Veneer columns with connectors that allowed them to pivot while being stiff for loads perpendicular to the surface.

The columns were constructed of 8" brick and reinforced. They supported the entire dead load of the wall, but the lateral connectors to the building were flexible in the vertical directions so that none of the building dead load was supported on the brick. The panels were constructed of 4" brick. They were shipped 600 miles from the fabrication yard to the building location.

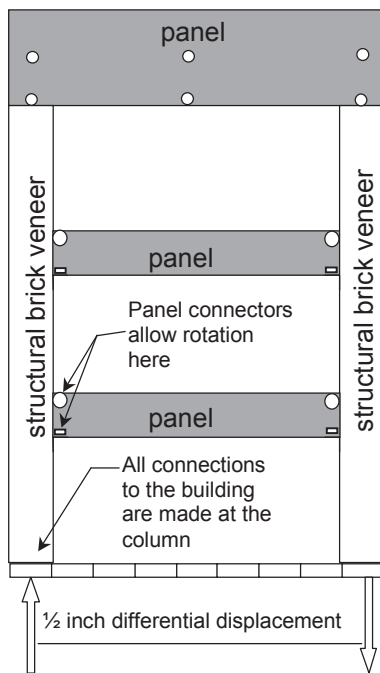

Figure 26 Concept for Settlement

### 3.3.2 Design for Code Loading

The reinforcement size and spacing are typically determined by conventional allowable stress design. Maximum moments usually occur at mid-span for

simple configurations or at connectors for cantilevered configurations. Both horizontal and vertical reinforcement should be provided because most walls behave as plates with moments in both directions. The design often proceeds, however, by assuming simple spans with full loading in each direction.

Maximum spacing of reinforcement should be less than 4 feet with 3 feet a common value. Typically, bar sizes are No. 3 and 4 bars in 4 inch walls and No. 3, 4 and 5 bars in 5 inch and 6 inch walls.

In areas of high shear, additional reinforcement may be required. Reinforcement should also surround connectors and openings.

### 3.3.3 Design for Wall Cracking

An important performance criterion is to prevent the cracking of brick. This condition usually is not a structural problem for reinforced brick masonry. But, it is an aesthetic problem. The design for this performance criterion is typically done as follows:

To prevent cracking of the brick, the moments in the horizontal direction (stiff direction) are compared to the resistance of the wall in that direction, see the following figure. Failure would involve cracking of the brick unit and the head joint. Cracking due to vertical moments would result in cracking of the horizontal bed joint which is not an aesthetic problem.

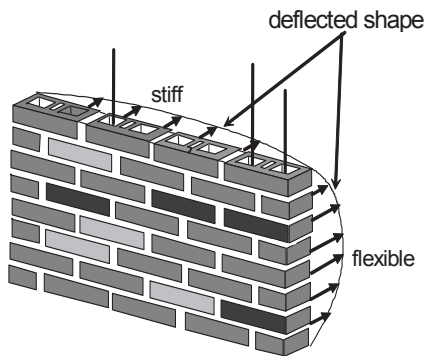

Figure 27 Stiffness of Brick Masonry

Unpublished tests and tests performed by Western States Clay Products in the early 1970's have shown that brick masonry in running bond direction is nearly 10 times as stiff as brick masonry in the vertical direction. For normal brick orientations, loads tend to run horizontally to the supports.

Most code wind loading is based on a mean return period of 50 years and this often represents a reasonable level of wind loading expected once in the life of the average building. However, in some cases, it may be appropriate to increase or decrease these levels to better match the criteria for the project.

Seismic loading would usually correspond to the moderate level earthquake. It is probably unreasonable to design to the major level earthquake to prevent an aesthetic problem.

The resistance of the wall is provided by the masonry without consideration of the reinforcement. The masonry is assumed

not cracked. Without the reinforcement, the resistance is provided by the bricks and mortar joints. It is conservative to assume that there is no capacity for the head joint to resist tension stresses, consequently all of the resistance is provided by the tensile capacity of the brick. Thus, the appropriate structural section available to resist the loading is only the brick which is normally one half the gross cross-section.

There are no national standards available to provide allowable stresses for brick in tension. The brick material supplier may have information or it may be necessary to do testing. In the absence of both, using 10% of the brick's compressive strength has generally proven conservative. Because the minimal consequences of the failure and the loading are expected to occur only once in the building life, it is recommended to use a small factor of safety on the tension capacity of the brick. A value of 1.25 has been successfully applied.

### 3.3.4 Design of Connections

Each configuration has a unique set of reactions for each code-required load combination. The reactions must be supported by the connectors and the structure. The connectors must be of sufficient strength and ductility to meet the capacity and ductility requirements.

#### Materials for Connectors

Most connectors are constructed of miscellaneous steel angles, tees and plates. For Level 1 (institutional) performance they are typically galvanized. For Level 2 (commercial) performance

they are shop painted. Stainless steel connectors are probably not warranted and there are only a few known installations.

### **Design Methods and Assumptions**

Conventional design methods apply to the design of the connectors, except for the design of the capacity of the connector to the Structural Brick Veneer. There are several additional design considerations.

First, the connector should engage more than one brick cell. Sometimes bricks have cracks as a result of manufacturing. Concentrating loads at a single cell of the brick could, if cracked, significantly reduce the capacity. Consequently, for the design of connectors in Structural Brick Veneer, the scale of the engagement into the brick should be at least two times that usually associated with connectors engaging reinforced concrete.

Next, because of the seismic requirement for connectors, "Anchorage using flat straps embedded in concrete or masonry shall be attached to or hooked around reinforcing steel or otherwise terminated so as to effectively transfer forces to the reinforcing steel or to assure that pullout of anchorage is not the initial failure mechanism", it is often necessary to thread reinforcement through holes placed in the steel. This may restrict the flow of grout at the connection and a recommended mitigation is to use bond beams above and/or below the connector.

### **Construction Tolerances**

An important factor in the design of a connector is construction tolerance. Structural Brick Veneer walls are located in plane and elevation with tolerances more restrictive than the supporting structure. For example, the deviation from plumb (down the height of the building) often is limited to 1/2 inch for Structural Brick Veneer. In a steel frame at the upper floors, the tolerance on the frame is 1-1/4 inches inward and 2-1/4 inches outward. The location of the slab edge is often plus or minus 1 inch.

The elevation of the floor also varies from the planned location. There are several reasons for this. First, there is construction tolerance. Second, the floor is supported on beams that deflect due to loading. Third, there is elastic shortening of the building and for concrete buildings, there is creep and shrinkage. Again, this uncertainty of floor elevation is important to the design of the connector. These tolerances have an important design and construction impact.

The connector must be designed to accommodate these deviations in dimension. The edge of floor connector should be configured to be installable with the slab edge at either extreme of the allowed tolerance. Additionally, the strength of the connector should be adequate to support the loads with the most unfavorable combination of element locations.

The configuration of the connector is often dictated by the tolerance requirements, and the resulting load eccentricity.

ties often (to the untrained eye) appear to oversize the connections.

### 3.4 Design Examples

Three design examples are presented. The first is a strip spandrel configuration supported on a continuous ledger. The second is the same except the veneer is supported on separate floor dead load connectors. The third example addresses seismic displacement design at a Structural Brick Veneer corner.

#### 3.4.1 Example 1

This example is very simple and unlikely to occur in actual practice. The designer is cautioned not to apply the methods and equations contained in this example to other applications. The purpose of the example is to demonstrate a sequence of assumptions and analysis appropriate for this simple design. Different assumptions and analysis methods should be used when the design changes.

A four-story office building with a “strip window” system serves as a common application. The story height is 12'-6", the window height is 6'-0" and the sill height is 2'-6". The wind load is 30 psf and the building is classified as seismic design category D. The wind load of 30 psf (according to most codes) is typically larger than the seismic inertia load perpendicular to the surface of the veneer and this is assumed for this example. Floor to floor drift isolation is provided by a slip joint in the window head. Warping of the glass accommodates drift at the building corners. In other words, the brick corner remains

rigid and moves with the floor to which it is attached.

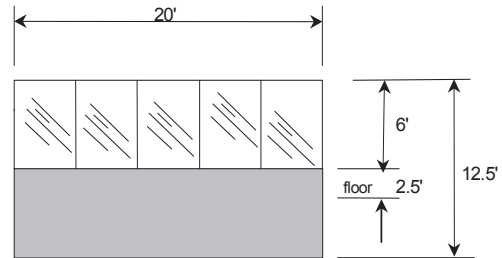

Figure 28 Strip System Example

A continuous ledger system is hung from the bottom of the spandrel beam and braced to the underside of the floor.

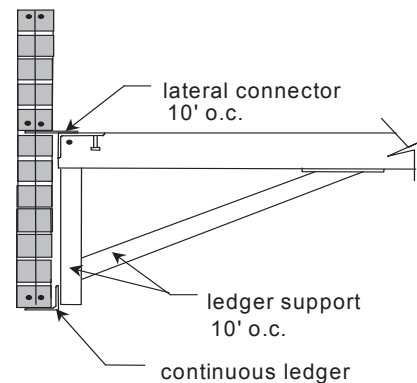

Figure 29 Support for the Wall

The hanger and brace are located at 10 feet on center. This matches the purlin spacing when the floor spans in the direction parallel to the edge of the slab. Assume 4-inch hollow brick is used. The actual thickness is 3.5 inches and the depth of the reinforcement from the surface is 1.75 inches.



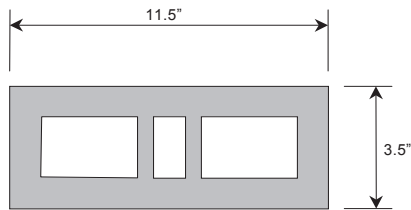

Figure 30 Brick Used in the Example

The design might proceed as follows:

The dead load on the ledger includes the weight of the brick veneer and the windows.

$$\text{Wall} = 40 \text{ psf} \times 6.5 \text{ ft} = 260 \text{ plf}$$

$$\text{Window} = 6 \text{ psf} \times 6 \text{ ft} = 36 \text{ plf}$$

$$\text{Total} = 296 \text{ plf}$$

Since the hangers are spaced at 10 feet, the hanger vertical load is:

$$296 \text{ plf} \times 10 \text{ ft} = 2960 \text{ lbs}$$

The ledger is designed to span between supports. In Structural Brick Veneer, the brick can also be used to span if shoring is used during construction. Assume the brick is used to span between supports, then try (2) #3 in a bond beam at the first course above the ledger.

The bending due to dead load is:

$$M_A = W L^2 / 8$$

$$M_A = 296 \text{ plf} \times 10^2 \text{ ft} / 8 = 3700 \text{ lb-ft}$$

The steel ratio “ $\rho$ ” is used to calculate the capacity to resist the loading.

$$\rho = A_s / bd$$

Where  $A_s$  is the area of flexural reinforcement,  $b$  is the width or thickness of the masonry and  $d$  is the depth of the flexural element from the extreme compression fiber to the centroid of the reinforcement.

$$\rho = .22 \text{ in}^2 / (3.5 \times (78 - 4))$$

$$\rho = .00085$$

Assume the masonry modulus of elasticity is 3,000,000 psi, and the steel modulus of elasticity is 29,000,000 psi then the modular ratio between the reinforcement and the masonry is:

$$n = E_s / E_m = 9.67$$

and then

$$n\rho = .00085 \times 9.67 = .0082$$

Most codes allow a design flexural stress for grade 60 reinforcement as:

$$F_s = 24,000 \text{ psi}$$

Similarly, the allowable masonry stress is 1/3 the specified strength. If 4000 psi is specified, then the allowable flexural masonry compression stress is:

$$F_b = 4000 / 3 = 1333 \text{ psi}$$

By summing forces in the direction along the flexural element, the following

expression for the location of the neutral axis can be obtained:

$$k = [(n\rho)^2 + 2n\rho]^{1/2} - n\rho$$

$$k = .12$$

A convenient term "j" is defined as:

$$j = (1 - k / 3) = .96$$

The moment capacity limited by the allowable reinforcement stress is defined as:

$$M_t = A_s j d F_s$$

Thus:

$$M_t = .22 \times .96 \times 74 \times 24000 / 12$$

$$M_t = 31,200 \text{ lb-ft}$$

The moment capacity limited by the allowable compression stress in the masonry is defined as:

$$M_c = bd^2kj F_b / 2$$

$$M_c = 3.5 \times 74^2 \times .12 \times .96 \times 1333 / (2 \times 12)$$

$$M_c = 122,600 \text{ lb-ft}$$

Since both  $M_t$  and  $M_c$  are greater than the applied moment,  $M_a$ , the two #3 bars provide more than adequate vertical support between ledger hangers.

If shoring is provided, a similar calculation would show that the vertical support could be extended to 20 feet or more and the weight of the wall reacted at the building columns.

However, as will be seen later, the lateral support (for wind and seismic loading) will need to be 10 foot. Thus, the hanger could be spaced at 20', but the braces back to the underside of the slab will need to be at 10'.

The wind load on the wall is 30 psf. This load acts perpendicular to the surface of the brick and the window.

Assume floor connections are spaced at 10 foot at the same location as the lateral support of the ledger.

The floor reaction is found by summing moments about the ledger:

The reaction of the window at the sill (top of the brick) is:

$$R_w = 3 \text{ ft} \times 30 \text{ psf} = 90 \text{ lb/ft}$$

The resulting moment about the ledger is:

$$M_w = 90 \text{ lb/ft} \times 6.5 \text{ ft} = 585 \text{ lb-ft/ft}$$

The moment about the ledger due to the wind loading on the brick is:

$$M_b = 30 \text{ psf} \times 6.5 \text{ ft} \times 6.5 \text{ ft} / 2$$

$$M_b = 634 \text{ lb-ft/ft}$$

The reaction resists the moments and is calculated as:

$$R_F = [ M_b + M_w ] / 4$$

$$R_F = [ 634 + 585 ] / 4$$

$$R_F = 304.7 \text{ lb-ft/ft}$$

## STRUCTURAL BRICK VENEER

Since the spacing of the connectors is at 10 feet on center, the connector reaction is:

$$R_F = 3047 \text{ lbs}$$

By summing forces perpendicular to the surface of the brick, the ledger lateral reaction is:

$$R_L = 12.5 \text{ ft} \times 30 \text{ psf} \times 10 \text{ ft} - R_F$$

$$R_L = 703 \text{ lbs}$$

Drawing the shear and moment diagrams reveals that the maximum moment occurs at the floor and is equal to the moment on the brick due to the window sill load plus the moment on the brick due to the wind on the brick:

$$M_w = 30 \text{ psf} \times 3 \text{ ft} \times 2.5 \text{ ft}$$

$$M_w = 225 \text{ lb-ft/ft}$$

$$M_b = 30 \text{ psf} \times 2.5 \text{ ft} \times 2.5 \text{ ft} / 2$$

$$M_b = 93.75 \text{ lb-ft/ft}$$

$$M_a = M_w + M_b$$

Thus:

$$M_a = 318.75 \text{ lb-ft/ft}$$

and over the 10 foot spacing becomes:

$$M_a = 3187.5 \text{ lb-ft}$$

An estimate of the required reinforcement can be obtained as follows:

$$A_s \cong M_a / [.9 F_s d]$$

$$A_s \cong (3187.5 \times 12) / [.9 \times 24,000 \times 1.33 \times 1.75]$$

$$A_s \cong .75 \text{ in}^2$$

Where the design depth is one-half the wall thickness (1.75 inches), and the stress has been increased by 1/3 for wind short duration loading.

Try (4) #4 bars. The brick module is 6 inches. The code allows an effective width for bending of six times the thickness of the wall. The width for design can be obtained by laying out the bars in the brick cells:

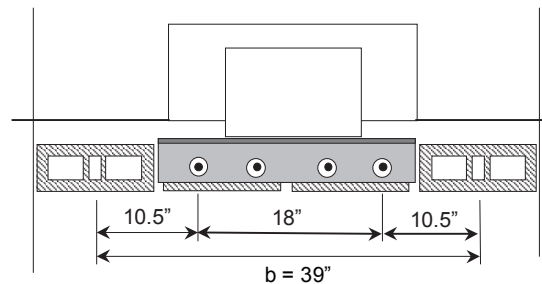

Figure 31 Plan View of Connector

And:

$$\rho = A_s / bd$$

$$\rho = 4 \times .2 \text{ in}^2 / (1.75 \text{ in} \times 39 \text{ in})$$

$$\rho = .0117$$

$$n\rho = .113, k = .37, j = .87$$

The moment limited by the allowable stress in the reinforcement is:

---

## STRUCTURAL BRICK VENEER

---

$$M_t = A_s j d F_s$$

$$M_t = .8 \times .87 \times 1.75 \times 24,000 \times 1.33 / 12$$

$$M_t = 3250 \text{ lb-ft}$$

The moment limited by the allowable stress in the masonry is:

$$M_c = b d^2 k j F_b / 2$$

$$M_c = 39 \times 1.75^2 \times .37 \times .87 \times 4000 \times 1.33 / (3 \times 2 \times 12)$$

$$M_c = 2840 \text{ lb-ft} \quad \text{n.g.}$$

Compression at the floor in the brick is often the limiting factor.

Add (2) #4 bars for a total of 6 bars. Then

$$b = 6 \times 3.5 + 5 \times 6 = 51 \text{ in.}$$

$$n\rho = (9.67 \times 6 \times .2) / (1.75 \times 51)$$

$$n\rho = .13$$

$$k = .40 \quad j = .87$$

$$M_t = 4870 \text{ lb-ft} \quad \text{ok}$$

$$M_c = 4025 \text{ lb-ft} \quad \text{ok}$$

The wind loading must span horizontally 10 feet to the vertical connector strips. Assume the window head reaction is reacted by the lateral bracing and the ledger, and the window sill reaction is reacted by the brick, then the moment in the brick is the moment caused by the window and the moment caused by the wind load on the brick.

$$M_w = 30 \text{ psf} \times 3 \text{ ft} \times 10^2 / 8$$

$$M_b = 30 \text{ psf} \times 6.5 \text{ ft} \times 10^2 / 8$$

$$M_a = M_w + M_b$$

$$M_a = 3562 \text{ lb-ft}$$

Assume (5) bond beams with (2) #3 in each, then:

$$A_s = 1.10 \text{ in}^2$$

$$\rho = 1.10 / (78 \times 1.75)$$

$$\rho = .00805$$

$$n\rho = .078, \quad k = .32 \quad j = .89$$

$$M_t = 1.10 \times .89 \times 1.75 \times 24000 \times 1.33 / 12$$

$$M_t = 4567 \text{ lb-ft} \quad \text{ok}$$

$$M_c = 78 \times 1.75^2 \times .32 \times .89 \times 1333 \times 1.33 / (2 \times 12)$$

$$M_c = 5038 \text{ lb-ft} \quad \text{ok}$$

The condition of dead load plus wind is satisfied by inspection, but can be checked as follows:

$$\begin{aligned} & [M_a / (M_t \text{ or } M_c)]_{\text{dead}} \\ & + [M_a / (M_t \text{ or } M_c)]_{\text{wind}} \\ & < 1.0 \end{aligned}$$

$$\begin{aligned} & 3700 / 3120 \\ & + 3562 / 4567 \\ & = .89 < 1.0 \end{aligned}$$

## STRUCTURAL BRICK VENEER

The condition of inertia seismic and dead load is also satisfied by inspection since the inertia seismic load was assumed less than the 30 psf wind load. This conclusion by inspection can easily be made when designing the veneer, but should not be so easily made when designing connectors. This is because most seismic codes have special load factors and additional criteria for seismic connector design that are not typical for the wind design of a connector.

The final check is for cracking of the brick.

Assume a service load of 15 psf. The value selected should relate to the design life and the performance criteria selected for the project.

The uniform horizontal loading of the strip between the connectors is a result of the wind load acting on the windows and brick. The moment is estimated as:

$$M_w = 15 \text{ psf} \times 3 \text{ ft} \times 10^2 / 8$$

$$M_w = 562.5 \text{ lb-ft}$$

$$M_b = 15 \text{ psf} \times 6.5 \text{ ft} \times 10^2 / 8$$

$$M_b = 1218.7 \text{ lb-ft}$$

$$M_a = M_w + M_b$$

$$M_a = 1782 \text{ lb-ft}$$

The section available to resist the moment is estimated as half the wall height since half of that height is head joints.

$$I = b t^3 / 12$$

$$I = (78/2) \times 3.5^3 / 12 = 139.3 \text{ in}^4$$

The stress is:

$$\sigma = Mc/I$$

$$\sigma = 1782 \times 12 \times 1.75 / 139.3$$

$$\sigma = 269 \text{ psi}$$

The brick unit should have a tensile strength in excess of 269 psi times the factor of safety. If 1.25 is used, then the tensile strength needs to exceed 335 psi.

According to an unpublished test and experience, to achieve an  $f'_m$  of 4000 psi the brick strength probably exceeds 10,000 psi. Using the 10% rule of thumb, the expected tensile strength of the brick is 1000 psi.

A simple lateral connector at the floor is shown in the following figure. It consists of an embedded WT 4 x 5 with a coupler welded to the flange for the attachment of a rod.

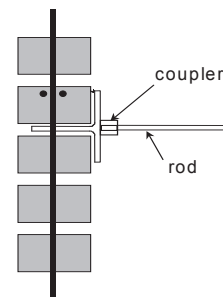

Figure 32 Simple Lateral Connector



---

## STRUCTURAL BRICK VENEER

---

The length of the tee will need to be determined based on the loads applied. To start, assume the tee is 22 inches long. The tee contains four 1-inch diameter holes for reinforcement placement. The capacity of the connector can be estimated by using a shear cone.

Assuming the shear cone originates at the bar then the height of the cone is:

$$h = 1.75 + .25 = 2.0 \text{ inches}$$

Assuming a 20 degree slope at the edge of the cone, the approximate surface area of the cone is:

$$A = \text{Length} \times \text{width} \times 2$$

$$A = \{2.0 / \cos 20^\circ\} \times 22 \times 2$$

The ends of the cone are neglected, but can be added if the capacity is insufficient.

$$A = 94 \text{ square inches}$$

Assuming the shear allowable is the same as the maximum shear allowable for beams of 50 psi (the masonry design strength exceeds 2500 psi and the 1/3 stress increase is used) then the allowable for the connector for pull-out is:

$$P = A \times 50 \text{ psi} \times 1.33$$

$$P = 94 \times 50 \times 1.33 = 6250 \text{ Lbs}$$

Another failure mode is the connector breaking the bond between the steel and masonry. The area of contact is:

$$A = \text{Length} \times \text{width} \times 2$$

$$A = 2.75 \times 22 \times 2 = 121 \text{ in}^2$$

The bond strength is assumed to be 60 psi plus the 1/3 stress increase. Thus, the capacity of the connector is estimated as:

$$P = A \times 60 \times 1.33$$

$$P = 121 \times 60 \times 1.33 = 9656 \text{ lbs}$$

The shear friction check results in:

$$A_v = V_u / \phi F_y$$

or

$$V_u = \phi A_v F_y$$

$$V_u = .4 \times 4 \times 2 \times 60,000$$

$$V_u = 19,200 \text{ lbs}$$

$$V = V_u / 2 = 9600 \text{ lbs}$$

The lowest allowable load is 6250 lbs compared to the applied wind load of 3047 lbs. A 10-inch long anchor would likely supply sufficient capacity, but only two of the six bars would be engaged making the design for ductility questionable.

It is assumed that the code level seismic inertial force is .315 times the force of gravity. The working stress design inertia loading is .315/1.4 or .225 times gravity. The brick weight is approximately 40 psf resulting in a surface inertial load of 9 psf and a reaction of  $3047 \times 9 / 30$  or 914 lbs. The connector factor of safety exceeds 7 for code level seismic loads. This satisfies the additional seismic criteria for connectors by inspection.

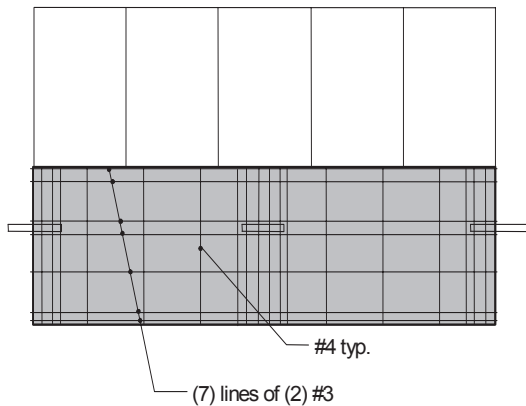

Figure 33 Final Design

Limited testing of connectors has been conducted. One recent test conducted by Western States Clay Products Association validated the design methods for the connection shown above. Other tests specific to special connections on projects have been conducted. They are unpublished, but also verify the above methods.

### 3.4.2 Example 2

The same strip window system is used for Example 2 except that the dead load support is now on separated connectors located at the floor. Shoring will be used to construct the wall. The design example is for the in-place condition only. In actual practice, the designer of the Structural Brick Veneer would design the system for the shoring conditions as well as the in-place condition.

The following figure presents the new layout of the connections.

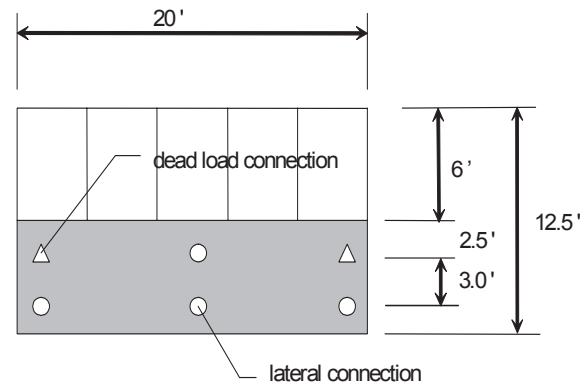

Figure 34 Location of Connectors

The veneer is assumed to have a vertical expansion joint at 20 feet on center. From the previous example, the horizontal span of the brick is limited to less than 10 feet. Thus, a lateral anchor at the floor and a brace will be required at the mid point of the panel.

The design dead load, after the wall is constructed, is the same as the previous example.

Placing the dead load anchors away from the columns will avoid interference with the building structure and make the installation easier. Assume the dead load anchors are placed at 2 feet from the column line. A vertical expansion joint is assumed at the column. The 2 feet dimension was chosen as the center of the head joint so that the connector is centered on the head joint and an even number of bars will pass through the connector. If an odd number of bars passes through the connector, then the anchor would be located at the center of a cell. Two feet three inches or

## STRUCTURAL BRICK VENEER

two feet nine inches from the expansion joint would be examples.

The reaction load on the dead load connector is:

$$R = w \times L / 2$$

$$R = 296 \times 20 \text{ ft} / 2 = 2960 \text{ lbs}$$

The maximum moment occurs at the mid span and is:

$$M_a = R \times \{L/2 - s\} - W \times \{L/2\}^2 / 2$$

$$M_a = 2960 \times (10 - 2) - 296 \times 10^2 / 2$$

$$M_a = 8880 \text{ lb-ft}$$

From the previous example, the wall can support this load.

The bending out of plane on the wall due to wind is assumed reacted by braces one foot above the bottom of the brick and at the floor. The reaction at the floor can be found by summing moments about the location of the brace as follows:

$$M_w = 30 \text{ psf} \times 3 \times [5.5 - 1] \text{ ft}$$

$$M_w = 405 \text{ lb-ft/ft}$$

$$M_b = 30 \text{ psf} \times [5.5^2 / 2 - 1^2 / 2] \text{ ft}^2$$

$$M_b = 438.75 \text{ lb-ft/ft}$$

$$R_{\text{Floor}} = [M_w + M_b] / 3$$

$$R_{\text{Floor}} = 281 \text{ lbs/ft}$$

Summing forces perpendicular to the veneer results in the horizontal brace force:

$$R_{\text{brace}} = 30 \times 12.5 - 281 = 94 \text{ lb/ft}$$

The maximum moment again occurs at the floor line and is:

$$M_a = 30 \times 3 \times 2.5 + [30 \times 2.5^2] / 2$$

$$M_a = 318.8 \text{ ft-lb/ft}$$

The contributing length of veneer for the dead load connector is about 6 feet consisting of the 2 feet of cantilever and half the distance to the center connector. The design moment is:

$$M_a = 318 \times 6 = 1908 \text{ lb-ft}$$

The layout of the connector at the column is shown in the following figure and results in 5 contributing #4 bars.

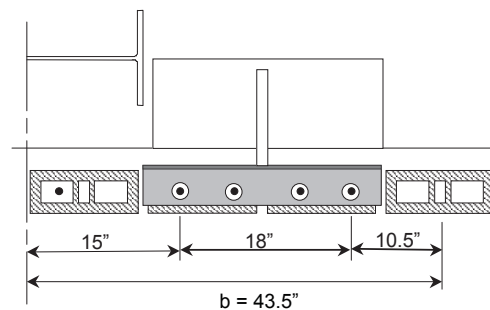

Figure 35 Plan View of Connector

Thus:

$$b = 43.5 \text{ in.}$$

$$A_s = 1.0 \text{ in}^2$$

$$\rho = 1.0 / (43.5 \times 1.75)$$

$$\rho = .013$$

$$n\rho = .127, \quad k = .39 \quad j = .87$$

$$M_t = 1.0 \times .87 \times 1.75 \times 24000 \times \frac{1.33}{12}$$

$$M_t = 4060 \text{ lb-ft} \quad \text{ok}$$

$$M_c = 43.5 \times 1.75^2 \times .39 \times .87 \times \frac{1333 \times 1.33}{(2 \times 12)}$$

$$M_c = 3347 \text{ lb-ft} \quad \text{ok}$$

But, this may not be the only out-of-plane moment in the masonry. Depending on the connector design, there could also be a significant moment added into the masonry as a result of dead load eccentricity

The connector will be designed next. Assume a configuration as shown in the following figure:

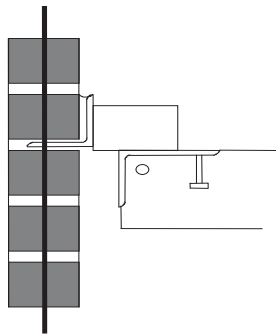

Figure 36 Dead Load Connector

The vertical reaction is 2960 lbs and the wind reaction is 6 feet x 281 lb/ft = 1686 lbs.

The eccentricity of the dead load is important to the design. It is calculated assuming an edge of slab tolerance of 1 inch as shown in the following figure.

$$e = 3.5/2 + 1 \frac{1}{2} + 1 \text{ (tol.)} + 3.0/2$$

$$e = 5.75 \text{ in.}$$

The resulting eccentric moment can be reacted either in the brick veneer or in the floor slab or by both. When the wall is shored, the connector installed and the shoring removed, the eccentric moment is reacted by both the wall and the floor slab. The amount of moment in each is very difficult to determine and will depend on the stiffness of the shoring as well as the manner in which the wall is built.

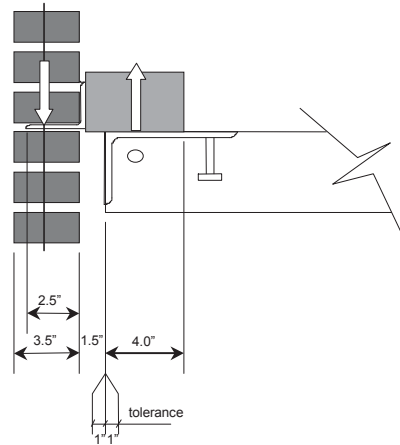

Figure 37 Dead Load Moment

A conservative approach to the design is to design assuming all of the moment is in the brick veneer and then assume all of the moment is in the floor. We will first assume the moment is in the brick veneer.

## STRUCTURAL BRICK VENEER

Assume the connector design is controlled by the combined dead load and wind condition. From the previous example, the dead load on the anchor is 2960 lbs.

The moment is in the brick wall, thus:

$$M_a = 2960 \times 5.75 \text{ in}$$

$$M_a = 17,202 \text{ lb-in}$$

This moment should be combined with the wind moment resulting in:

$$M_a = 17,202 + 1908 \times 12$$

$$M_a = 40,100 \text{ lb-in or } 3340 \text{ lb-ft}$$

The previous design using (5) #4 bars provides adequate resistance.

Now, check the local capacity of the connector to transfer the load into the veneer. Assume the moment is inserted into the veneer wall by forces consisting of shear on the horizontal leg of the angle and bearing on the vertical leg of the angle. If a triangular distribution of bearing on the vertical leg is assumed, the force is:

$$P = 17,202 / (6 \times 2/3)$$

$$P = 4,255 \text{ lbs}$$

Note that the moment due to wind is not included. The wind load moment is already in the veneer. The reaction of the wind at the floor must, however, be added to the horizontal leg of the angle.

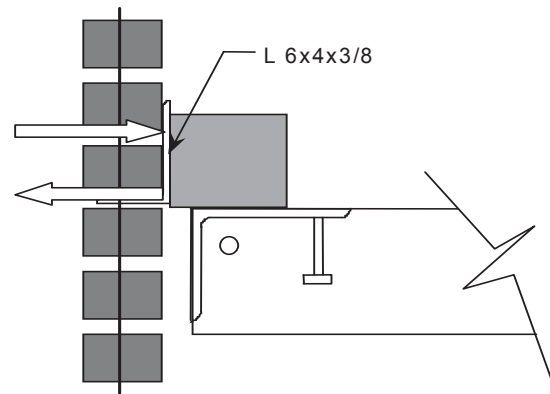

Figure 38 Resisting Moment

$$P = 4255 \text{ lb} + 281 \text{ lb/ft} \times 6 \text{ ft}$$

$$P = 5942 \text{ lbs}$$

Assume the failure is in the bond between the horizontal leg of the angle and the masonry. Using 60 psi shear allowable and 2.5 inch contact length, both top and bottom, the required length of contact is:

$$L = 5942 / (2.5 \times 2 \times 60 \times 1.33)$$

$$L = 14.8 \text{ in}$$

Or, using the cone pull-out check the length becomes:

$$P = 2 \times (d/\cos 20^\circ) \times L \times 50 \times 1.33$$

$$L = P / (141.5 \times d)$$

$$L = 5942 / (141.5 \times 2.0)$$

$$L = 21 \text{ in.}$$

Therefore use a 24 inch long angle.



The shear friction method can also be used:

$$A_v = V_u / \phi F_y$$

or

$$V_u = \phi A_v F_y$$

$$V_u = .4 \times 6 \times 2 \times 60,000$$

$$V_u = 28,800 \text{ lbs}$$

$$P = 28,800 / 2 = 14,400 \text{ lbs ok}$$

The 2003 International Building Code requires the fasteners and body of the connector to be designed to equation 9.6.1.3-2 which is a maximum value. Lower values are likely for many structures using equation 9.6.1.3-1.

$$F_p = 1.6 S_{DS} I_p W_p$$

Using  $S_{DS} = .75$  (a high value)

$$F_p = 1.65 \times .75 \times 1.0 \times W_p$$

$$F_p = 1.24 \times 40 \text{ psf} = 49.6 \text{ psf}$$

the design level is:

$$F = 49.6 \text{ psf} / 1.4 = 36 \text{ psf.}$$

This is higher than the design wind load of 30 psf and controls.

$$P = 4255 \text{ lb} + 281 \times \{36/30\} \times 6$$

$$P = 6278 \text{ lbs}$$

$$L = 6278 / (141.5 \times 2.0)$$

$$L = 22 \text{ in.}$$

Use a 24 inch angle.

The bearing of the brick wall on the horizontal leg of the angle is seldom limiting in design and is satisfied here by inspection.

Now check assuming the moment is in the floor. By inspection, the brick veneer is adequate. The design of the plate, welds and embedded plate is all that is required. Assume the worst situation of the tolerance for the edge of slab results is 3 inches of connection between the slab embed and the plate.

The analysis is the same as would be performed for a precast concrete panel or other wall system. Examples can be found in many references.

The design results in a 1/2 inch thick vertical plate. The weld on the vertical leg of the angle should also be a 3/8 inch fillet 4 inches long on both sides. And the weld on the plate to the embed should be a 3/8 inch fillet 3 inches long on both sides.

Notice that the size of the weld exceeds the thickness of the plate. This is because the design factors of safety for the weld loaded by seismic forces was assumed larger than that required for the body of the connection.

The 24 inch angle is a conservative size since both the brick and slab connection are designed for the moment. If a more detailed analysis were made, the length of the angle could probably be reduced. The cost savings, however, would likely not justify the reduction in capacity.

**3.4.3 Example 3**

The final example will demonstrate the design of a corner for seismic isolation. Assume a 12'-6" story height. The corner is constructed of Structural Brick Veneer with a width of 10 feet from the corner. Given that the elastic seismic drift is .31 inch, the building is a specially reinforced concrete moment frame with a  $C_d$  of 5.5, and assuming the building is a hospital with the corner above the emergency entrance, the maximum expected floor drift is:

$$\Delta = 5.5 \times .31 = 1.7 \text{ inches}$$

The corner can support part of the wind loading, but a lateral connector will be needed 10 feet away from the corner.

Since the brick is 10 times stiffer in the running bond direction, most of the resistance to the movement is reacted at the corner.

The analysis of this corner displacement is complex. It can be visualized by considering a flat rectangular panel of veneer 12'-6" by 10 feet laid flat horizontally on the floor with anchors at the corners. The analogous displacement is to lifting up one of the four corners of the flat panel while the other three are held to the floor.

The load deflection calculation for this condition is complex and includes bending in two axis and torsion. And, again the veneer is not isotropic.

Making a simplifying assumption that half the height participates with bending about the stiff direction only, then the

load required to deflect the wall 1.7 inches is calculated as follows:

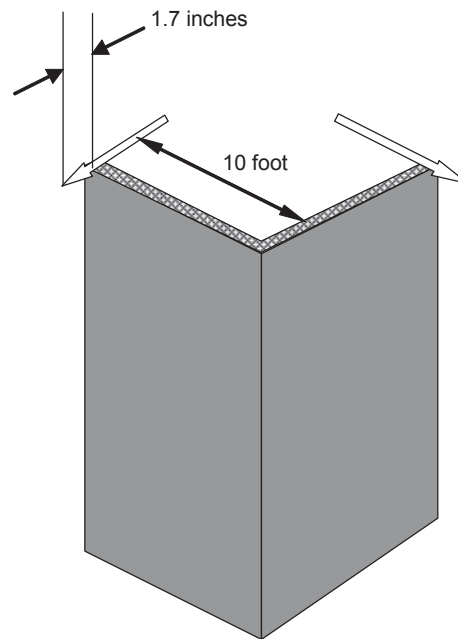

Figure 39 Warping Corner

$$\Delta = PL^3 / (3 \times E_m \times I)$$

The head joints are assumed cracked so the contribution of the wall is half.

$$I = 1/12 \times \{(6' - 3'') / 2\} \times 3.5^3$$

$$I = 134 \text{ in}^4$$

$$\Delta = 1.7 \text{ inches}$$

$$P = 1.7 \times 3 \times 3,000,000 \times 134 / (120^3)$$

$$P = 1186 \text{ lbs}$$

The resulting stress in the brick is:

$$\sigma = M c / I$$

$$\sigma = 1186 \times 120 \times 1.75 / 134$$

$$\sigma = 1860 \text{ psi}$$

If the entire wall height were assumed to resist the displacement, the stress would not change because the stiffness increases in proportion. Because the stress exceeds the likely tensile capacity of the brick, the wall will crack.

This is acceptable according to our criteria provided the panel remains intact. Notice that the wall will likely remain uncracked for half the ultimate displacement resulting in no damage.

Reinforcement will be required to hold the panel together.

Sufficient reinforcement must be provided to assure ductile behavior. The cracking moment is:

$$M = (1186 \times 1000 \text{ psi}) / 1860 \times 10 \times 12$$

$$M = 76,500 \text{ lb-in}$$

Where the tensile capacity of the brick is assumed to be 1000 psi.

The estimate of the reinforcement is:

$$A_s = 76,500 / (60,000 \times 1.75)$$

$$A_s = .72 \text{ in}^2$$

Four bond beams with two #3 bars will be sufficient. Notice that 60,000 psi was used for the steel stress. The assumed

yield strength should be compared to the ultimate cracking strength since this part of the design is for ultimate seismic.

#### 4.0 Specification

The Structural Brick Veneer System consists of several components that must be specified and detailed. The following discussion should help in this process.

#### 4.1 Quality Control and Assurance

According to the International Building Code and ACI 530-02/ASCE 5-02/TMS 402-02 *Building Code Requirements for Masonry Structure*, the designer needs to specify the required inspections and quality control tests. Structural Brick Veneer projects are designed either in accordance with Chapter 2 or Chapter 3 of ACI 530-02/ASCE 5-02/TMS 402-02 or Sections 2106, 2107 or 2108 of the International Code.

The International Code requires inspections at Level 1 (Table 1704.5.1) for non-essential facilities and Level 2 (Table 1704.5.3) for essential facilities. These tables identify activities requiring full time and periodic inspection during construction.

It is recommended that prism tests for each 5000 square foot of wall be performed in accordance with Level 3 quality assurance (Table 1.15.3) in ACI 530-02/ASCE 5-02/TMS 402-02. The verification of  $f'_m$  can be either by prism test or the unit strength method.

### 4.2 Masonry

Generally, brick is selected for its color, texture, and size. The most common brick specified is ASTM C 652 Hollow Brick. More detailed information about the hollow brick can be found at:

[http://www.bia.org/html/frmset\\_thnt.htm](http://www.bia.org/html/frmset_thnt.htm),  
Technical Note 41 Hollow Brick  
Masonry.

Most Structural Brick Veneers are constructed of bricks with nominal thickness of 4, 5 or 6 inch.

Mortar should be Type S, Portland cement, hydrated lime, and sand. Type S mortar exhibits higher flexural bond strength while providing sufficient compressive strength. Type M mortar is generally too stiff at the time of laying to result in good bond, and thus may leak more and is harder to clean.

The durability of the wall is highly influenced by the quality of the mortar joints. Care should be taken to ensure that dense joints are achieved. Joints should be tooled to a concave or "V" finish to densify the mortar surface and improve bond between the mortar and the brick. If raked joints are desired, a "deep V" may achieve the effect. Simple raked joints must be tooled after raking.

Grout is the material placed in the cells of the brick. The proportions are similar to mortar, except that sufficient water has been added to provide a fluid consistency. Grout should be poured in brick masonry with a slump exceeding 10 inches.



Figure 40 Fluid Grout

The excess water in the grout is absorbed into the brick before hydration. Reconsolidation of the grout is required to remove the voids left by the water absorbed into the brick. The specification should require reconsolidation or the additive Grout Aid.

It is recommended to add Sika Grout Aid to all installations. This is a proprietary product, but the only one known to be specifically designed for addition to grout. More information can be obtained at:

[http://www.sikaconstruction.com/con/con-admixture\\_in\\_con-prod-category-ga.htm](http://www.sikaconstruction.com/con/con-admixture_in_con-prod-category-ga.htm)

Sika Grout Aid is a balanced blend of expanding, retarding and water-reducing agents for Portland cement grouts. It provides a slow, controlled expansion prior to the grout hardening.

Other manufacturers claim equivalence, but often lack test data to support product performance. In structural brick

masonry, the important property of the grout is to fill all of the space and voids, and to make the connection between the reinforcement and the brick unit. The strength is of secondary importance, since the brick unit compression strengths typically exceed 8000 psi.

If an additive other than the Sika Grout Aid is used, a test should be performed to assure filling of the space and bonding to the units and reinforcement. This likely means the preparing of a grout sample panel and cutting it after curing to visually confirm the performance.

The reinforcement is usually specified as ASTM A 615 Grade 60. Deformed bars are required and sizes are limited by the thickness of the wall. Generally, bars larger than No. 5 are not used. When reinforcement is to be welded, ASTM A706 bars should be specified. It is slightly more expensive but it can be welded without becoming brittle. ASTM A706 bars can be identified by a "W" mark on the bar.

Joint Reinforcement is not recommended for Level 1 projects. Experience with galvanized metal in masonry on the exterior walls indicates a life of 30 years or less.

Reinforcement bars grouted into bond beams will have an expected life greater than 30 years.

### **4.3 Steel for Connectors**

Connectors can be designed and constructed in many forms. Most are made from ASTM A 36 structural steel angles, plate, rods, channels, tees and

other available shapes. Connectors may be shop-painted for Level 2 (commercial) installations. Connectors for Level 1 (institutional) installations should be hot-dip galvanized to meet ASTM A 123 Grade 65 requirements. Connectors that are not protected can possibly corrode, stain the brick, and ultimately fail to resist the loading. Damage to galvanized coatings by welding or other field installation practices should be repaired using cold galvanizing compounds.

The use of 300 series stainless steel is generally not necessary and may be subject to galvanic corrosion if placed in contact with galvanized steel.

### **4.4 Flashing/Weeps**

Continuous flashing is necessary for the removal of water that enters the cavity space. In masonry, water enters the surface of the wall and then gravity pulls it downward. When the masonry is interrupted by openings that provide a horizontal discontinuity, flashing is required to intercept the water and direct it out of the building.

Flashing material for the Structural Brick Veneer System is the same as the materials used in other types of brick wall construction.

Pea gravel, proprietary meshes or screens above the flashing will help to prevent mortar droppings from clogging weep holes. Weep holes should be spaced no more than 32 inches apart. Open head joint weep holes are recommended. Weep tubes and cotton wicks often fail to function when they become clogged or damaged. Screens

in open head joint weeps can be used to deter insect infestations.

It is important that the flashing extend through the thickness of the wall in order to intercept the flow. Whether or not flashing should protrude from the wall is controversial. Since the flow of water on the surface of the wall is in all directions, a flashing that protrudes from the surface intercepts the flow at caulk joint. This is the weakest point for water to penetrate the wall.

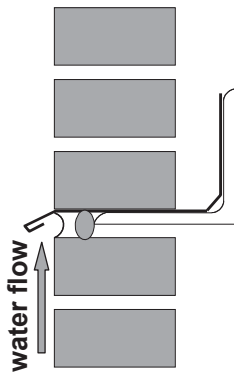

Figure 41 Protruding Flashing Detail

Flashing not protruding will allow the water to pass over the weak point. However, water intercepted by the flashing from the interior and exiting at the weep holes above the flashing may have a better chance of re-entering the building.

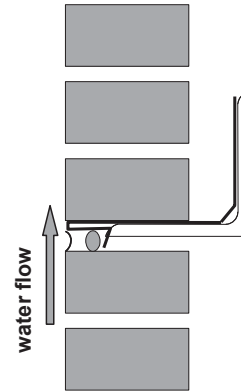

Figure 42 Flush Flashing Detail

#### 4.5 Sealants

Sealants provide the first line of protection against rain intrusion into the system. Placement of sealants should be accomplished in conformance with the manufacturer's recommendations. Joints should be properly prepared, cleaned with solvent, primed for adhesion and backed with a backer rod.

Sealant compatibility tests (peel test) conforming to ASTM C 794 should be conducted for each type of brick unit used and all other materials in direct contact with the sealant, including flashing. The compatibility tests should also be conducted on treated (sealed) brick, unless the treatment is to be done after sealing. The compatibility tests are important to assure bond between the sealant and the brick.

#### 4.6 Water Repellents

Water repellents are desirable for a variety of reasons. The principal reason is to limit water ingress due to wind-driven



rain. By reducing the water that enters the wall, the repellent provides several benefits, both aesthetic and related to engineering performance that would justify their use. Some of these attributes are:

1. Efflorescence control.
2. Reduction of algae growth as a result of the absence of moisture in the pores and capillaries of the masonry.
3. Atmospheric pollutants that are dissolved in precipitation are not absorbed into the masonry.
4. Freeze-thaw damage is reduced when there is no water in the substrate to freeze.
5. Thermal efficiencies of the masonry wall are maintained since water is a good thermal conductor.

Although a number of technologies have been utilized in the formation of masonry water repellents, silane/siloxane monomer and polymer blends have a proven track record. In the Pacific Northwest where there are heavy wind-driven rains, Fabrishield 761 silane/siloxane water repellent has been proven over time to be an excellent clear water repellent. These types of water repellents are formulated to penetrate into the pores and capillaries of the masonry assembly where they react with the moisture and alkalinity and actually chemically fuse onto the mineral material in the linings of the pores and capillaries. During this chemical bonding

process, a conversion occurs in the repellent material that fully develops the hydro phobic (water repellent) properties.

An additional benefit to the manner in which these repellents function is that they tend to bond along the pore linings rather than build films across the pore openings. This ensures that sufficient vapor transmission can occur to maintain "breathability" in the assembly. Repellent manufacturers state a repellent life of up to 10 years, but there are numerous projects in the Pacific Northwest that have never had to have a second application.

One of the most controversial topics nationally is when and if water repellent should be used for brick construction. As outlined above, there are many positive job results obtained by properly applied clear water repellent. While most experts acknowledge the positive attributes, the primary concern is the severe problems that can occur if an improper repellent is applied. Most western states brick manufacturers are knowledgeable about the issues and can recommend which repellents will work with their products. However, the repellent manufacturer must warrantee the performance of the repellent in service. The performance problems arise when other repellent salesmen (and there are many) convince the specifier that their product is equal to the specified repellent and will save money and the "equal" product is then used. Our advice is this: DO NOT SUBSTITUTE! Demand past successful performance of the proposed coating on the specific manufacturer's brick, for a

number of years, under the same type of exposure. Demand that the repellent manufacturer's application instructions be followed.

### 4.7 Backup Wall

Structural Brick Veneer installations do not require a separate backup wall. A backup wall is sometimes constructed as a second air and water vapor barrier. Many Level 2 (commercial) buildings do not require the extra water and air protection since a well-designed drainage wall is often sufficient.

If a back-up wall is used, many options are available including metal studs with sheathing. The studs are typically not designed for the wind loading since the brick wythe is structurally designed to resist the wind.

### 4.8 Cavity

When a backup wall is provided, the cavity or air space behind the brick can be any width. The cavity acts to provide a buffer for wind-driven rain and allows water that penetrates the Structural Brick Veneer to migrate down the backside of the brick without migrating across the cavity space. Connectors should be designed and constructed to direct any of this water toward the backside of the brick instead of into the building.

The cavity should be kept clear of any obstructions that might allow water to bridge across. Mortar droppings should be prevented from falling into the cavity. Construction tolerance on the cavity width should be limited to  $\pm 1/2$  inch. At

each floor, fire safing is required to stop smoke and heat from moving between floors. The safing can act as a bridge for water to enter the building. Flashing over the safing should be provided.

### 4.9 Expansion Joints

Expansion joints need to be provided at various strategic locations in the Structural Brick Veneer wall system. Expansion joint placement is dictated by two considerations. First, expansion joints may be provided in locations where the brick wythe is likely to crack and second, to provide isolation from building movement. In Structural Brick Veneer systems, the spacing of vertical joints can be increased over that of conventional veneers because the reinforcement provides additional resistance to cracking.

The Brick Institute of America Technical Note 18A, Differential Movement - Expansion Joints, contains a valuable discussion on the many considerations involved in expansion joints.

[http://www.bia.org/html/frmset\\_thnt.htm](http://www.bia.org/html/frmset_thnt.htm)

As a general rule, vertical expansion (movement) joints should be provided at the following locations:

1. At or near wall corners
2. At wall discontinuities
3. At changes in height
4. At changes in thickness
5. At changes in stiffness
6. Adjacent to dissimilar materials
7. At abutments to other building elements

The joint size should be a minimum of twice the calculated amount to meet the limitations of the compressibility of the sealant. As a minimum, it is recommended that the joint not be less than 3/8 inch.

### **4.10 Window Anchorage**

Windows are usually anchored to the Structural Brick Veneer and not to the backup wall. In some installations, connectors are included in the design to make the attachment. In other installations, powder-actuated fasteners shot into the masonry have been used to make the connection. The choice depends on the loading and local practice.

## **5.0 Construction**

### **5.1 General**

The construction phase of the project begins with the award of the Contract for Construction. If the Structural Brick Veneer was specified as bidder designed, then the design of the Structural Brick Veneer may begin with the beginning of the construction. In this event, there is usually limited time for the design and it should begin without delay.

Once designed, a Structural Brick Veneer project construction is similar to any other structural brick project.

The mason contractor is normally a subcontractor to the general contractor. If the Structural Brick Veneer is bidder designed, the mason contractor usually becomes responsible for the design. If the design is part of the contract documents, the mason contractor will still

need to prepare shop drawings detailing the installation.

Most mason contractors do not normally prepare shop drawings for reinforcement. Thus, the responsibility for providing an adequate set of shop drawings can become lost in the process of bidding. The general contractor thinks the mason will prepare the shop drawings and the mason thinks the general contractor will prepare the shop drawings.

Often, the mason contractor does not supply the reinforcement for the wall. The general contractor supplies it. The design team should become aware of who will supply the reinforcement. It will have some influence on how the project proceeds.

Experience has shown that the preferred choice is for the mason contractor to purchase the reinforcement and supply the shop drawings. However, some mason contractors may bid high or even not bid at all as a result of this requirement. The resulting cost pressure may require the design team to be flexible about the requirement for shop drawings and their preparation.

Sometimes the general contractor will supply the shop drawings using his normal reinforcement detailer. Unfortunately, the detailer may have limited experience with masonry (the expertise is concrete) and the drawings submitted are often full of errors or items that cannot be constructed.

## 5.2 Construction Sequence

Several construction trades construct structural Brick Veneer. The dead load support angle (or connectors) and lateral braces are usually installed by the steel erector or the general contractor. These trades prefer to complete their work with the completion of the building structural frame. But if this is done, the mason is constrained by constructing the brick to match the installed connectors.

For example, for a Structural Brick Veneer supported on a continuous ledger, if the ledgers are all installed prior to the laying of the brick, it is nearly impossible to place the vertical reinforcement and grout the wall. It is usually necessary to delay installation of the ledgers until after the brick below is completed.

If a backup wall is constructed, it is usually installed by a different contractor and at a different time than the Structural Brick Veneer. Normal choices for the inside wall include masonry, concrete or steel studs. For a Structural Brick Veneer System, however, the masonry and concrete choices are unlikely because the stiffness and strength of the backup wall are no longer required.

When metal studs are used, it is common to sheath the outside face of the stud to provide additional water and air infiltration protection. The sheathing must be installed before the Structural Brick Veneer. Thus, the connectors typically penetrate the sheathing. This requires additional coordination between the trades.

## 5.3 Pre-Construction

Once the general contractor and the mason subcontractor have been selected, the engineer should verify the mason's qualifications with the local masonry institute and the local material suppliers. This information will be helpful for determining the amount of time and effort that will be needed during construction.

At an appropriate time, usually at least two months before the start of masonry construction, arrange for a preconstruction conference to discuss the masonry construction. Attendees should include:

1. The mason contractor and foreman.
2. The general contractor and superintendent.
3. The building official.
4. The architect.
5. The special inspector, when required.
6. The engineer.
7. The owner's representative.
8. The brick supplier.
9. The window supplier.
10. The dry-wall installer.

Subjects for discussion include:

1. Brick:

Determine the availability and delivery schedule of the selected brick. If the unit strength method is used to verify required masonry strength, verify that the brick will meet the required strength.

### 2. Initial testing:

If the unit strength method was used to establish the design strength  $f'_m$ , then mortar, grout and prism testing prior to construction are not required. However, it is recommended that when full allowable stresses were used in the design, prism testing should be conducted prior to construction. As a minimum, unit testing or manufacturer's certification is required.

For Structural Brick Veneer installations, a grouting test panel is often necessary to demonstrate the grouting procedures. The schedule should be defined. The design team, building official and special inspector should be present for the grouting demonstration.

Often the grouting demonstration panel can also be used as a color and quality control panel for the architect.

### 3. Testing During Construction:

Prism testing is recommended for each 5,000 square feet of wall. During construction, three prisms constitute a test, however, five are recommended. Test the first one at seven days, the next three at 28 days and hold the final sample for testing in case of a problem.

If prism tests are conducted, grout and mortar tests are usually not required.

### 4. Inspection:

ACI 530-02/ASCE 5-02/TMS 402-02  
*Building Code Requirements for  
Masonry Structures.*

The inspector should regularly check the preparation of mortar and grout to ensure proper proportions and the laying of units to ensure proper workmanship. The inspector should verify and ensure full compliance with the contract documents for the placement of reinforcement, grouting and the protection of the masonry from rain, dirt, cold and/or hot weather.

### 5. Observation:

Inform all participants that from time to time representatives of the design team will visit the site to ensure general compliance with the contract documents.

### 6. Inspection Reports:

Normally, test reports and inspection reports go to the general contractor; then to the architect; and then to the engineer. Deviations from this normal procedure should be discussed, defined and documented.

### 7. Submittals:

Verify that the required project submittals have been approved or are in the process of being approved.

### 8. Cleaning and Water Repellents:

The procedures to be used to clean and apply water repellents should be discussed. It is important that the mason contractor verify the cleaning method with the unit manufacturer. If water repellent is to be applied, the method and materials to be used should also be verified with the brick manufacturer.

Proper water repellents do not seal the wall. Masonry must breathe. Painting contractors often are not experienced with applying water repellents to masonry, and assuring understanding of proper methods is important.

### 9. Construction Sequence and Schedule:

The successful installation of a Structural Brick Veneer project requires coordination of many trades (see previous discussion). Ask the general contractor questions to ensure that the construction sequence and responsibilities have been defined. Discuss the schedule for inspection and testing. Discuss coordination issues. One usually missed item is the coordination with the window and door supplier. The design of the connections should be discussed.

### 10. Window Attachment:

As previously discussed, the attachment of the window and coordination of the flashing system will be important to the successful performance of the wall. Too often this important coordination is left to the last minute or not done at all. The pre-construction conference is a good opportunity to discuss the issue and assign responsibility.

### 11. Sealant Installation:

Often the sealant installer is a separate subcontractor from the Structural Brick Veneer and window contractors. The specified sealant may or may not be compatible with the brick, mortar, water repellent and window-supporting member finish. These building elements,

and often others, all come together at the sealant joints. The selected sealant and installation procedures should be checked for compatibility with adjacent materials.

### 12. Compliance Testing

Most Structural Brick Veneer projects require compliance testing. When the brick supplier is not experienced with the system, testing of prisms in accordance with national standards should be completed before construction begins. Testing during construction is also generally required. During the pre-construction conference, the compliance testing required should be communicated to all involved.

### 5.4 Submittal Review

Items submitted for review include the following:

#### 1. Mortar proportions and laboratory test:

The mortar submittal is usually only submitted by type. This is satisfactory provided the mortar is specified by proportions, not strength, and provided there is a method to control the proportions of the mortar.

The contractor may submit proportions other than by type. In this case, laboratory tests should be performed to verify the compressive strength of the mortar (ASTM C 270).

#### 2. Grout proportions:

Specify grout in accordance with proportion requirements of ASTM C 476.



Do not specify grout by the minimum strength of 2,000 psi. The proportions will result in strengths well in excess of 2,000 psi.

Lime may be added to grout. This usually improves the grout properties by increasing flow and retention of water, resulting in improved placement and bonding to the unit.

The additive Grout Aid should be added to the grout as recommended by the manufacturer.

For batch-provided grout, the proportions are normally described by weight. The weight proportions should be converted to volume proportions for comparison with ASTM C 476.

### 3. Unit certifications:

The unit manufacture should provide certificates that the masonry units comply with the requirements specified.

### 4. Reinforcement shop drawings:

These should be scheduled to provide sufficient time for review and resubmittal prior to construction. Experience has shown that rejection of the first set of drawings is likely.

### 5. Connector shop drawings:

Shop drawings showing the detailing of reinforcement, connectors and embedded items need to be submitted with sufficient time for review.

### 6. Quality control program:

When required by the specification, the quality control program should be written by the mason contractor and submitted in time for review and discussion with all involved, including the inspector and general contractor.

## 5.5 Site Visits

The structural engineer should make site visits to check on the progress and quality of the work. This part of the engineer's scope of services is called construction observation. It is defined in AIA C141 Section 2.6.3 as:

"The consultant shall visit the site at intervals appropriate to the stage of construction for This Part of the Project, or as otherwise agreed with the Architect in writing, to become generally familiar with the progress and quality of the Work completed for This Part of the Project and to determine in general if the Work is being performed in a manner indicating that the Work, when completed, will be in accordance with the Contract Documents. However, the consultant shall not be required to make exhaustive or continuous on-site inspections to check the quality or quantity of the Work for This Part of the Project. On the basis of such on-site observations as a consultant, the consultant shall keep the Architect informed of the progress of the Work for This Part of the Project and shall endeavor to guard the Owner against defects and deficiencies in such work. (More extensive site representation may be agreed to as an Additional Service, as described in Paragraph 3.2)."

## 5.6 Non-Conforming Quality Control Tests

Experience has shown that the field-testing of masonry is highly variable. The source of the variability can be the materials, the methods used to prepare the samples, the testing of the samples and the interpretation of the results. Before rejecting a wall because of non-conforming field-testing, the engineer should carefully assess the possible causes of the field test non-conformance and possibly remove and test samples from the actual wall.

### 5.6.1 Unit Compression Strength

If the Unit Strength Method for establishing and verifying the specified compression strength,  $f_m$ , then prism tests (or unit compression tests) are required prior to and during construction. The tests prior to construction should provide assurance that the units and masonry will be satisfactory. If the test prior to construction does not comply with the required strength, then another brick may be required, or the project may have to be redesigned for a lower strength.

Sometimes the brick tests prior to construction are not performed and the units are tested during construction and do not conform. In this case, a new analysis may be required to verify strength. One option is to use Strength Design provisions based on UBC Section 2108. These methods are less sensitive to low compression strength. But, the engineer should be careful about excess deflections and other serviceability

issues when designing with Strength Design.

When prism (units) are tested prior to construction and conform to the requirements, but do not conform to the requirements when tested during construction, the problem is probably in the manufacturing of the prisms or there was a change in the testing procedures or materials. The units should be tested (or re-tested). If the units still do not comply, the code allows prism testing to verify strength. Construct prism tests to verify the strength.

If the prism strengths do not comply, a redesign or change in the brick unit may be required. Non-conforming walls will likely require removal.

### 5.6.2 Mortar Compression

It is recommended that field-testing of mortar not be required. Prism testing every 5000 square feet of wall should be specified. However, the requirement for mortar testing often is not within the control of the structural engineer, and on many projects mortar testing becomes a requirement.

The field sampling and testing for mortar compression strength is highly variable. The following figure is a frequency distribution of field mortar compression tests taken from actual projects in California, Oregon and Washington. There are a total of 205 mortar tests. The coefficient of variation is 36%.

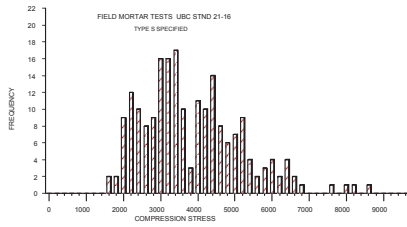

Figure 43 Variation of Field Mortar Tests

With this amount of variability, it should not be surprising to get periodic non-conforming compression mortar tests. If the non-conformance occurs regularly, then the following steps are recommended:

1. Request from the mason the proportions being used.
2. Assess the method being used to control proportions.
3. Verify that the testing lab is using the procedures of ASTM C 780.
4. Visit the site and observe the mortar in the joint. Scratch the mortar with a key. If a white scratch results and the sand does not separate from the mortar, the strength of the mortar is probably acceptable. However, if the masonry is highly stressed (above 1200 psi) it may be necessary to remove a prism from the wall for testing.

The relationship between 7-day mortar strength and 28-day mortar strength is fairly consistent from sample to sample. It is useful to know the 7-day test results since they provide the engineer with an early indication of the 28 day results. The following figure presents the relationship.

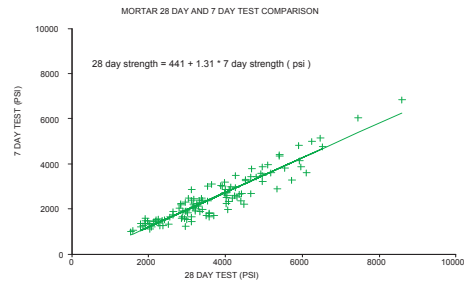

Figure 44 Mortar 7 day and 28 Day Tests

### 5.6.3 Grout Compression

It is recommended that field-testing of grout not be required. Prism testing every 5000 square feet of wall should be adequate quality control. However, the requirement for grout testing often is not within the control of the structural engineer, and on some projects grout testing becomes a requirement.

The field sampling and testing for grout compression strength is highly variable. The following figure is a frequency distribution of field grout compression tests taken from actual projects in California, Oregon and Washington. There are a total of 323 grout tests. The coefficient of variation is 32%.

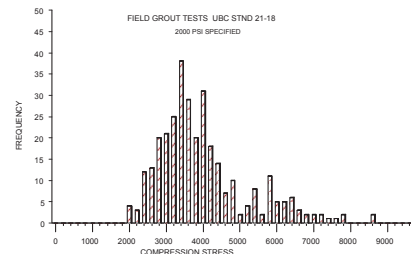

Figure 45 Variation of Field Grout Tests

With this amount of variability, it should not be surprising to get periodic non-conforming compression grout tests. If the non-conformance occurs regularly, then the following steps are recommended:

1. Request from the mason the proportions being used.
2. Assess the method being used to control the proportions.
3. Verify that the testing lab is using the procedures of ASTM C1019.
4. If the cause of the low break is not identified, then taking core samples and testing them may be required.
5. The structural engineer should also consider the reason for requiring the specific grout strength. Often, the purpose of the grout is only to connect the reinforcement to the units. Even low strength grouts (1500 psi) are probably capable of making the connection. Because of the high strength of the brick, the compression contribution of the grout can often be ignored in the analysis.

The relationship between 7-day grout strength and 28-day grout strength is also consistent from sample to sample. It is useful to know the 7-day test results since they provide the engineer with an early indication of the 28-day results. The following figure presents the relationship for the same projects.

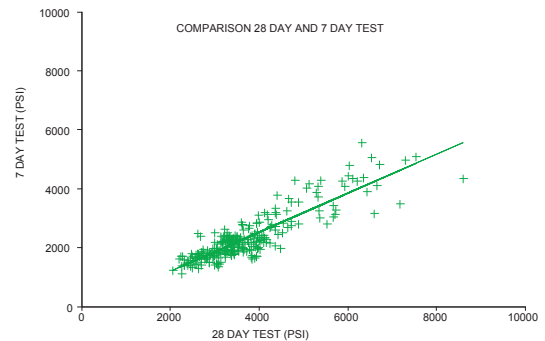

Figure 46 Seven Day and 28 Day Grout Strength

### 5.6.4 Prism Tests

Prism tests are less variable than either mortar or grout testing and provide the engineer with a higher level of confidence that the masonry system has the desired strength.

When prism tests do not conform, verify that the materials used (units, mortar and grout) conform to the specifications. If they do conform, then either the prism was improperly constructed or the testing procedures were not in compliance with ASTM 1314.

Improper construction of prisms includes not constructing the prism true and plumb. It is very important that the top and bottom planes of the prism are parallel. Another common problem for large cell units (8" units and larger) is that the grout is not properly re-consolidated. Without proper re-consolidation, a dome-shaped void will often form at the mortar joint part way up the height of the prism and render the area of grout ineffective for resisting compression.

Common testing errors include not properly capping the prism so that the top and bottom planes are level and parallel, not using a testing machine with a spherical head, and not providing a thick enough loading platen to distribute the test machine load evenly to the prism. It has also been reported that some testing labs stop loading at the first sound emitted. The first sound may correlate to the failure of a concrete cylinder, but does not typically correlate to the failure of a masonry prism.

### **5.7 Troubleshooting During Construction**

The following table is presented to assist the engineer with problems often occurring during construction. This table was developed over the years based on the experience of the authors. It has been evolving and it often seems that contractors have a special ability to create new situations not previously considered or addressed. Proceed with caution.

Troubleshooting Table for  
The Design and Construction of Structural Brick Veneer

PROBLEM	CAUSE	SOLUTION
Prisms fail to reach the design strength.	<ol style="list-style-type: none"> <li>1. The testing lab has incorrectly tested the prism, usually by not placing the prism correctly in the machine or using a loading platen that is too thin. Or the specimens may have been damaged during transportation.</li> <li>2. The bricks are below the specified strength.</li> <li>3. The mortar is under specified strength.</li> <li>4. Lab reported gross area stress instead of net area stress.</li> <li>5. Lab stopped testing with first noise.</li> </ol>	<ol style="list-style-type: none"> <li>1. Instruct the lab to retest being careful to follow the ASTM C 1314.</li> <li>2. Request that the contractor have a lab retest the brick. If still too low, change the brick or redesign.</li> <li>3. Check mortar proportions. Retest the prisms.</li> <li>4. Have the lab correct the report.</li> <li>5. Re-test.</li> </ol>
Mortar doesn't reach strength.	<ol style="list-style-type: none"> <li>1. Incorrect proportions.</li> <li>2. Incorrect testing.</li> </ol>	<ol style="list-style-type: none"> <li>1. Check mortar quality control procedures.</li> <li>2. Mortar tests are unreliable. Forget about testing mortar. The code doesn't require it, if prisms are tested.</li> </ol>
Colors do not meet expectations.	<ol style="list-style-type: none"> <li>1. Bricks were not blended.</li> <li>2. Sample panel has different sealer.</li> <li>3. The brick production run is different from the sample run.</li> </ol>	<ol style="list-style-type: none"> <li>1. This is a problem for the architect and brick supplier. There are paints available, but results are questionable.</li> <li>2. Use the sample panel sealer.</li> <li>3. Approve the production run before beginning construction.</li> </ol>
Someone calls and says more expansion joints are required.	Someone was checking on your advice. They should do this, so don't get mad.	Explain how the reinforcement reduces the need for most of the expansion joints.
The mason tells the general who tells everyone that the cells are too small to be grouted with all the congested steel.	<ol style="list-style-type: none"> <li>1. The mason contractor does not have experience with grouting of reinforced hollow brick. He doesn't understand that he can make the grout with an 8 to 11 inch slump.</li> <li>2. The cell is too small.</li> </ol>	<ol style="list-style-type: none"> <li>1. Prepare and grout a test panel. Be sure to invite everyone concerned.</li> <li>2. Use a different cell size.</li> </ol>



## STRUCTURAL BRICK VENEER

PROBLEM	CAUSE	SOLUTION
Welded bars are breaking off.	ASTM A 706 bars were not used.	Inspect bars. A "W" symbol indicates type A 706. Use the correct bars.
Contractor is not protecting his materials or work.	Sometimes the responsibility for protecting the work is left with the general contractor. He is saving money. Sometimes the responsibility is not well defined.	Write a letter to your client. Explain the consequences. Send a copy to the brick manufacturer.
Cracks in the mortar joints.	<ol style="list-style-type: none"> <li>1. Shrinkage of the mortar joint.</li> <li>2. Movement of the supporting structure.</li> <li>3. Overloading.</li> <li>4. Too rapid drying.</li> </ol>	<ol style="list-style-type: none"> <li>1. Suggest the contractor decrease the cement content of the mortar and increase the lime.</li> <li>2. Check supports.</li> <li>3. Check the loading, the timing of the loading and shoring removal.</li> <li>4. Pre-wet the units. Wet the wall during curing. Add lime to the mortar.</li> </ol>
Shop drawings are not prepared.	The requirement was missed or "value engineered away".	Write a letter to your client explaining the requirement. If the project is underway, require an engineer familiar with the design be on site full time.
The grout strength is specified at a minimum of 2000 psi, how can I get a prism of 4000 psi.	This is normal.	Explain that the prism does not fail in accordance with the weak link theory.
The contractor wants to high-lift grout with lifts larger than 6'	The code restricts the grout lift to 6' even though the grout pour might be higher.	The problem is blow-outs of mortar joints and the ability to reconsolidate. In hollow clay, these problems are unlikely. Have the contractor demonstrate the procedure to you and the inspector.
The contractor doesn't want clean-outs. You want high-lift grouting.	Code requires clean-outs for high-lift, in order to remove the mortar droppings.	In most Structural Brick Veneers the shear stresses are low. It is usually possible to waive the clean-out requirement.

## STRUCTURAL BRICK VENEER

PROBLEM	CAUSE	SOLUTION
The dowels out of the concrete foundation or ledger interfere with the unit cross webs. They miss the cells.	Improper placement of the dowels. However, it is often very difficult to get them in the right place. This situation should not occur in a Structural Brick Veneer.	Cut the unit cross webs to allow the dowel to pass or drill in new dowels. Verify that all the dowels are required to meet strength requirements. Do not, allow the dowels to be bent.
The brick masonry is cracked, with cracks extending through the units.	<ol style="list-style-type: none"> <li>1. A great deal of force is required for this condition to exist. The cause is likely a problem.</li> <li>2. The bricks may have been manufactured with the cracks.</li> <li>3. Foundation cracks extend into brick wall.</li> </ol>	<ol style="list-style-type: none"> <li>1. Find the reason for the cracking. It is likely that something needs to be corrected. Likely candidates include frozen grout, foundation movement, or thermal movement from adjacent structure.</li> <li>2. Verify the integrity of the units before use. A quick check is to bang the bricks together, If a ringing sound results instead of a thud, then the bricks are sound.</li> <li>3. Foundation control joints need to be coordinated with the masonry expansion joints.</li> </ol>
Contractor doesn't cover the walls at the end of the day.	<ol style="list-style-type: none"> <li>1. The contractor is attempting to save money.</li> <li>2. The responsibility for the masonry protection may have been left with the general contractor or worse, left out of all the contracts.</li> </ol>	<ol style="list-style-type: none"> <li>1. Insist on covering the walls.</li> <li>2. Write a letter stating that the contractor is not in conformance with the likely result being efflorescence and other wall damage.</li> </ol>
Corrosion of the joint reinforcement.	<ol style="list-style-type: none"> <li>1. Too strong an acid cleaning without pre-wetting the wall.</li> <li>2. Ungalvanized joint reinforcement.</li> </ol>	<ol style="list-style-type: none"> <li>1. Pre-wet the wall and use industry cleaners as recommended by the manufacturer of the units.</li> <li>2. Use galvanized joint reinforcement.</li> </ol>

### 6.0 Testing

Many different pre-construction mockup tests are available for evaluating the performance of the Structural Brick Veneer System design and construction. Pre-construction mockup testing is not necessary for all projects, and because of the costs involved, is likely feasible only for large projects. Tests are generally conducted to evaluate air, water and structural performance.

Veneer System. A standard test procedure, ASTM E 330, is available for testing exterior windows and curtain walls. Brick panel strength tests can be conducted in accordance with ASTM E 72. There are no standard tests for specifically measuring seismic performance.

### 6.1 Air

When air infiltration tests are conducted on the building mockup, they should be performed in accordance with ASTM E 783, while those conducted in the laboratory should be performed in accordance with ASTM E 283. Air infiltration tests should normally be done before water penetration tests because water trapped in the brick veneer tends to reduce air leakage.

### 6.2 Water

Water penetration tests for the brickwork should be performed in accordance with ASTM E 514, to measure the permeability of the constructed wall. Additional large-scale mockup tests are available using the procedures contained in AAMA 501.3, developed for testing aluminum curtain wall systems.

### 6.3 Structural

Structural tests measure a system's performance under lateral loading or deflection. This type of testing provides a means for accurately assessing the complex behavior of the Structural Brick

## ALLIED ASSOCIATES AND WEB ADDRESSES

- |          |   |  |
|----------|---|--|
| <b>1</b> | <b>Arizona Masonry Guild</b>            | ( <a href="http://www.masonryforlife.com">www.masonryforlife.com</a> )         |
| <b>2</b> | <b>Masonry Advisory Council</b>         | ( <a href="http://www.maconline.org">www.maconline.org</a> )                   |
| <b>3</b> | <b>Masonry Industry Promotion Group</b> | ( <a href="http://www.masonrypromotion.com">www.masonrypromotion.com</a> )     |
| <b>4</b> | <b>Masonry Institute of America</b>     | ( <a href="http://www.masonryinstitute.org">www.masonryinstitute.org</a> )     |
| <b>5</b> | <b>Masonry Institute of Oregon</b>      | ( <a href="http://www.mioctio.org">www.mioctio.org</a> )                       |
| <b>6</b> | <b>Masonry Institute of Washington</b>  | ( <a href="http://www.masonryinstitute.com">www.masonryinstitute.com</a> )     |
| <b>7</b> | <b>Rocky Mountain Masonry Institute</b> | ( <a href="http://www.rmami.org">www.rmami.org</a> )                           |
| <b>8</b> | <b>Southwestern Brick Institute</b>     | ( <a href="http://www.swbrick.com">www.swbrick.com</a> )                       |
| <b>9</b> | <b>Utah Masonry Council</b>             | ( <a href="http://www.utahmasonrycouncil.org">www.utahmasonrycouncil.org</a> ) |

