

SERVICE PRO[®]

CONTROL CENTER WITH MCD[®] TECHNOLOGY

GENERAL SPECIFICATIONS

The contractor shall furnish and install one complete Service Pro control center with MCD technology as described in the following specifications. Monitoring, Compliance and Diagnostic (MCD) functions for the domestic wastewater treatment system and auxiliary equipment shall be accomplished by combining solid state microprocessor technology with optional advanced telemetry and web-based data acquisition. The control center shall operate the Singulair wastewater treatment plant and monitor the entire system, including up to three auxiliary treatment components. Once commissioned, the telemetry system shall communicate with the Service Pro website and monitoring center to record all maintenance and alarm details. The website shall function as the user interface to manage all operational data with password protected access available to distributors, service providers, regulatory agencies and homeowners.

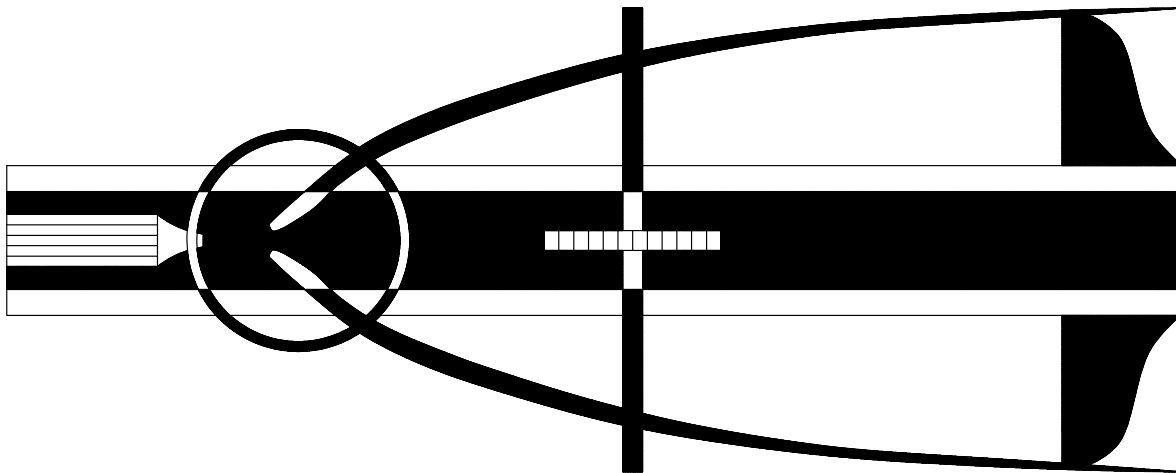

OPERATING CONDITIONS

The Service Pro control center with MCD technology shall be UL Listed and provide Monitoring, Compliance and Diagnostic functions for the Singulair wastewater treatment plant and auxiliary equipment using a microprocessor based platform. The microprocessor shall contain nonvolatile memory to prevent loss of programming in the event of a power failure. When used with the Singulair Model 960 system, the programmed run cycle shall not permit the aerator to be "off" for more than thirty minutes per hour. When used with the Singulair Model TNT system, the programmed run cycle for the aerator shall be sixty minutes "on" and sixty minutes "off." The control center shall be housed in a NEMA rated electrical enclosure designed specifically for outdoor use. Control centers that do not include integral telemetry equipment require multiple enclosures with interconnecting wiring and shall not be considered for this application.

SPECIFICATIONS

SERVICE PRO®

MONITORING FUNCTIONS

The Service Pro control center shall monitor the operation of the Singulair system and up to three auxiliary treatment components. The performance of the Singulair aerator shall be constantly monitored to detect any aerator over current, aerator under current or open motor condition. If any one of these conditions is detected, power to the aerator shall be interrupted, a diagnostic sequence shall begin and the visual alarm shall activate. After a factory programmed recovery interval, an automatic restart attempt shall be initiated. If normal aerator operation does not resume during 24 programmed recovery and restart cycles, the audible alarm shall activate and, if the telemetry system has been enabled, the control center shall report the specific condition to the Service Pro monitoring center. In the event that any of the auxiliary inputs detect an operational problem, the audible and visual alarms shall immediately activate and, if the telemetry system has been enabled, the control center shall report the specific alarm condition to the monitoring center. The distributor shall be automatically notified by the Service Pro monitoring center of the specific alarm condition using phone, fax or email.

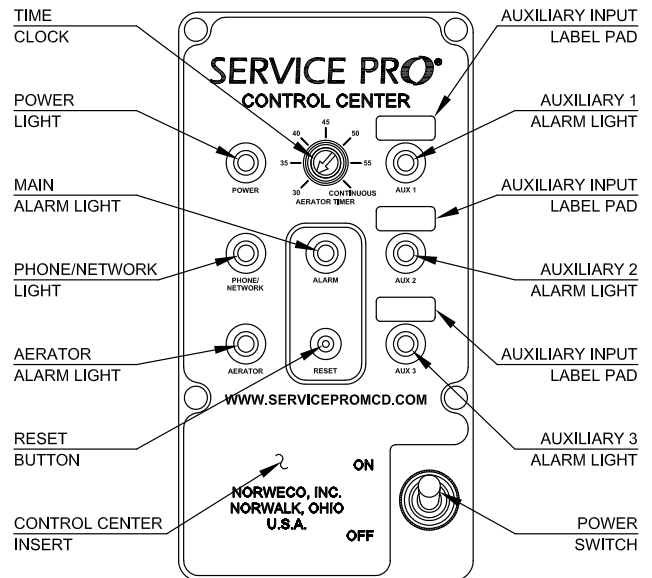

**SERVICE PRO CONTROL CENTER
MODEL 960 SYSTEM**

COMPLIANCE FUNCTIONS

The Service Pro control center shall insure compliance with regulatory requirements by confirming normal system operation, providing remote system monitoring and automatically recording operating data and service visits. Distributors shall have the ability to grant regulatory agencies access to reports about installations in their jurisdiction that have been recorded on the Service Pro website. The optional integrated telemetry system shall enable the Service Pro control center to communicate with the monitoring center via standard residential telephone or Internet service. By use of the alarm reset button, the monitoring center shall be notified of the beginning and end of any service visit. The monitoring center shall provide a time and date stamped record of each service visit and post the data to the Service Pro website. If telemetry is enabled, the control panel shall automatically contact the monitoring center monthly and deliver a heartbeat call indicating proper system operation. If the heartbeat call is not received, the monitoring center shall provide notification to the service provider indicating the system has not confirmed proper operation and a site visit is required. Control centers and/or telemetry systems without the heartbeat feature do not provide proactive confirmation of system compliance and shall not be considered for this application.

DIAGNOSTIC FUNCTIONS

The diagnostic functions of the Service Pro panel shall insure automatic identification of any alarm condition from the Singulair system or accessory equipment. Excessive load on the aerator from any cause, including effluent pump failure, a Bio-Kinetic system requiring service or system high water, shall result in the control center visual alarm indicating an aerator over current condition. An open electrical circuit anywhere in the control center or aerator, a broken service wire between the control center and the aerator, open motor windings within the aerator or an aerator that has been left unplugged shall activate the visual alarm indicating an aerator under current condition. Any aerator alarm condition shall activate the diagnostic sequence during which the control center shall allow for a temporary condition to correct itself before a call is made to the remote monitoring center. The diagnostic sequence shall include up to 24 automatic restart attempts within a two hour period. During this diagnostic period when the control center is attempting to automatically restart the Singulair aerator, pushing the reset button shall result in a manual restart attempt. Any successful restart attempt shall return the system to normal operation and the visual alarm shall deactivate. If the condition has not been corrected after 24 manual or automatic restart attempts, the control center shall activate the audible alarm and, if the telemetry system has been enabled, notify the monitoring center of the specific alarm code. Any auxiliary equipment malfunction shall immediately activate the control center audible and visual alarms. If enabled, the telemetry system shall then call the monitoring center to identify the specific auxiliary alarm.

CONTROL CENTER COMPONENTS

The Service Pro control center shall use a microprocessor based platform to control and monitor the wastewater treatment system. Nonvolatile memory built into the solid state circuit board shall prevent programming loss in the event of a power failure to the facility being served. The pre-wired controls shall be mounted in a lockable NEMA rated enclosure designed specifically for outdoor use. The corrosion resistant enclosure shall have knockouts molded into the bottom surface to facilitate installation of electrical conduit and the system phone or network line. Each control center shall be a UL Listed assembly and shall include a time clock, main alarm light, reset button, power switch, power light, phone/network light, aerator alarm light and three auxiliary alarm lights. The power switch shall control power for all Service Pro control center and aerator functions. The green power light shall be lit when the controls are energized and is the only light that will be illuminated during normal system operation. The yellow phone/network light shall be illuminated when the telemetry system is communicating. The red aerator alarm light shall be illuminated when normal operation of the aerator has been interrupted. The red auxiliary input lights shall illuminate only when the respective optional device requires service. The main alarm circuit of the Service Pro control center shall contain both visual and audible alarms and a reset button. Both the audible and visual alarms shall comply with the requirements of NSF/ANSI Standard 40 and Standard 245 regarding visual and audible signaling equipment. The main alarm light shall be visible through the closed door of the enclosure via a red weatherproof lens. When activated by either an aerator or auxiliary alarm, the main alarm light shall flash a programmed pattern to indicate the specific alarm condition. The reset button shall be centrally located on the control center and accessible from outside the enclosure via a weatherproof boot. Pressing the reset button shall cause a manual restart attempt of the aerator and re-initiate the programmed run cycle. If the audible alarm has been activated, pressing the reset button shall silence the alarm. The visual alarm shall remain active during the time the audible alarm is silenced. If the alarm condition has not been corrected after 48 hours, the audible alarm will reactivate. If telemetry is enabled, the control panel shall automatically call the Service Pro monitoring center. Data transmitted by the control center shall be received by the monitoring center and recorded in the database maintained via the Service Pro website. The monitoring center shall automatically notify the distributor or service provider when a Service Pro panel reports an alarm condition or fails to initiate a monthly heartbeat call.

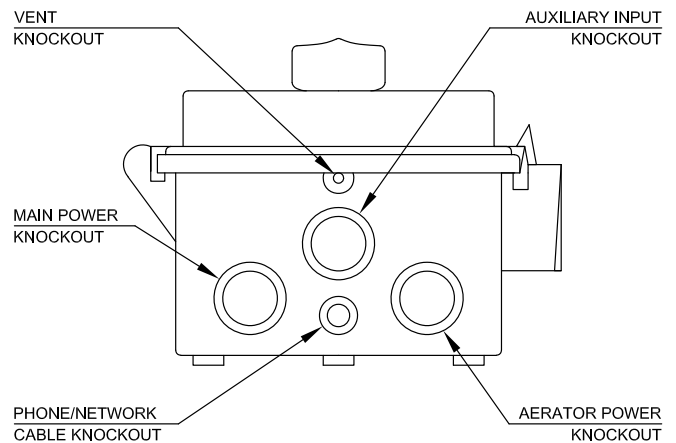

BOTTOM OF ENCLOSURE WITH KNOCKOUTS

The red auxiliary input lights shall illuminate only when the respective optional device requires service. The main alarm circuit of the Service Pro control center shall contain both visual and audible alarms and a reset button. Both the audible and visual alarms shall comply with the requirements of NSF/ANSI Standard 40 and Standard 245 regarding visual and audible signaling equipment. The main alarm light shall be visible through the closed door of the enclosure via a red weatherproof lens. When activated by either an aerator or auxiliary alarm, the main alarm light shall flash a programmed pattern to indicate the specific alarm condition. The reset button shall be centrally located on the control center and accessible from outside the enclosure via a weatherproof boot. Pressing the reset button shall cause a manual restart attempt of the aerator and re-initiate the programmed run cycle. If the audible alarm has been activated, pressing the reset button shall silence the alarm. The visual alarm shall remain active during the time the audible alarm is silenced. If the alarm condition has not been corrected after 48 hours, the audible alarm will reactivate. If telemetry is enabled, the control panel shall automatically call the Service Pro monitoring center. Data transmitted by the control center shall be received by the monitoring center and recorded in the database maintained via the Service Pro website. The monitoring center shall automatically notify the distributor or service provider when a Service Pro panel reports an alarm condition or fails to initiate a monthly heartbeat call.

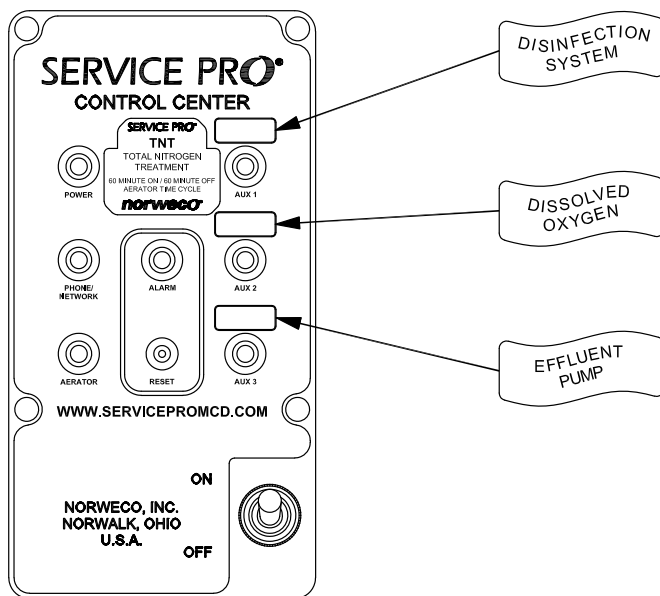

MODEL TNT CONTROL CENTER WITH AUXILIARY ALARM LABELS

MODEL 960 SYSTEM OPERATION

When a Service Pro control center is used with the Model 960 Singulair system, the aerator run cycle shall be controlled by an adjustable, pre-wired time clock. The minimum setting shall not permit the aerator to be "off" for more than 30 minutes per hour. The time clock shall be adjustable in 5 minute increments and designed so that any adjustment results in additional run time up to "continuous" operation (60 minutes per hour). Use of a time clock can seriously affect system performance and operating cost. Systems that have not been performance certified at the minimum time clock setting by an independent testing laboratory shall not be considered for this application.

MODEL TNT SYSTEM OPERATION

The Service Pro control center supplied with the Model TNT Singulair system shall be equipped with a factory programmed timer that controls aerator operation. The non-adjustable timer shall create a 60 minute aeration cycle followed by a 60 minute anoxic cycle during which the aerator shall be "off". A total of twelve hours of aerator operation per day shall be provided.

MCD® TECHNOLOGY

AUXILIARY ALARMS

The Service Pro control center shall contain three auxiliary alarm inputs to monitor accessory components. Each auxiliary input shall allow connection to a voltage signal, normally open relay contacts or normally closed relay contacts, using the appropriate input terminals and jumpers. The voltage input connections are located along the left edge of the circuit board and shall automatically adjust to accept any input voltage from 5 to 120 VAC/DC without programming or jumper adjustment. The relay input connections are located along the top edge of the circuit board and shall be configured for normally open (O) or normally closed (C) relay contacts by placing jumpers over the appropriate pins (labeled JP7, JP8 and JP9). Any auxiliary alarm signal shall activate that specific auxiliary alarm light and the main alarm light, sound the audible alarm and call the remote monitoring center if the telemetry function is enabled. Once connected to the remote monitoring center, the Service Pro control center shall identify which auxiliary alarm has been activated. Each auxiliary input shall be labeled in the space provided on the insert using the factory-supplied preprinted labels. The auxiliary inputs shall be used to monitor wastewater treatment equipment only. Connection of household appliances, security systems or other unauthorized equipment is prohibited and shall void the limited warranty.

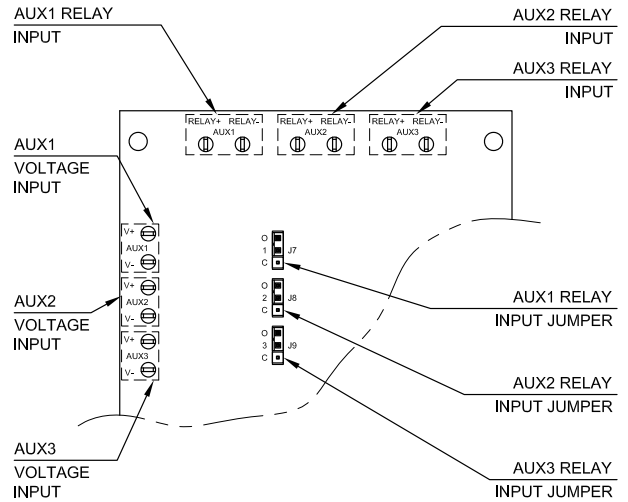

AUXILIARY ALARM INPUTS

TELEMETRY FUNCTIONS (Optional)

Optional integrated telemetry shall permit interactive communication between the monitoring center and the Singulair system, including all auxiliary equipment. The panel shall be factory programmed to contact the Service Pro monitoring center where the database of specific system information and a call record is maintained. The control center shall be shipped from the factory with the telemetry function disabled. Following panel installation and execution of the remote monitoring agreement, a commissioning process shall activate the telemetry function and establish communications with the Service Pro monitoring center via a toll-free telephone number or Internet connection. During normal operations, the heartbeat feature shall initiate a communication to the monitoring center at monthly intervals. The panel shall also contact the monitoring center to report alarm conditions. During each communication, the control center shall identify the individual installation and deliver the operational status or specific alarm code. The panel shall confirm receipt of the message before ending the communication. If not confirmed, the panel shall repeat until successful. The telemetry system shall have the ability to share a phone line or Internet connection with the facility being served. A dedicated telephone line or Internet connection shall not be required. If a telephone line is utilized, the panel shall automatically check phone line availability before initiating a call. If the phone line is not available, the system shall check every five minutes until the line becomes clear. When a clear line is available, the panel shall connect with the monitoring center. If the telemetry system is in the process of communicating and the telephone is picked up, the telemetry system shall immediately disconnect. The telephone shall be available for use after the person attempting to initiate a call momentarily hangs up to clear the phone line. The panel shall continue to monitor use of the telephone line. When the control center detects the telephone line is available for use, the telemetry system shall repeat the interrupted communication to the remote monitoring center.

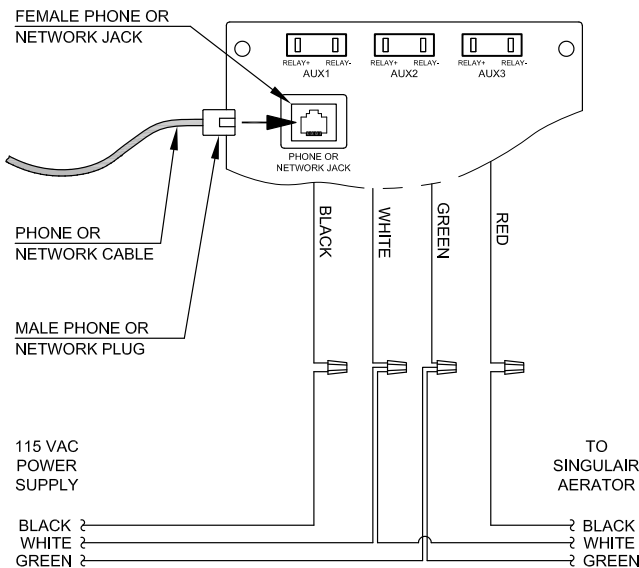

WIRING DIAGRAM

SPECIFICATIONS

SERVICE PRO® MONITORING CENTER

The Service Pro monitoring center shall include a 128 bit encrypted, password protected website for interface with the database of wastewater treatment system information. Access to the secure website shall be obtained through a unique user name and password that gives users tiered access to data from the wastewater treatment systems being monitored. Access levels shall include distributors, service providers, local regulatory agencies, state regulatory agencies and individual system owners. Distributors and service providers shall be able to create accounts, maintain service records and grant regulatory agencies access to the website. Individual system owners shall be able to view information regarding their own systems, as well as download instructional information. The monitoring center database shall contain the following information for each system registered: owner's name and system address, aerator serial number, control center serial number, system model number(s), auxiliary alarm information, accessory equipment information, permit information, service contract information, account status, service history and complete alarm history. Access to all wastewater treatment system information shall be password protected and limited exclusively to distributors, service providers, regulatory agencies and system owners. Integrity of stored data shall be maintained through the use of multiple servers operating in geographically isolated locations.

COMMISSIONING PROCESS

The Service Pro control center shall be programmed to initiate communications with the website and remote monitoring center via the commissioning process. Commissioning shall typically be initiated at Singulair system start-up and shall require no special tools or electronic equipment. The colored indicator lights on the face of the control center insert shall be used to confirm each step through the commissioning process. The Service Pro telemetry system shall send a communication to the monitoring center identifying the control panel and indicating that telemetry features have been enabled. If the control center has been correctly commissioned, the red alarm light in the center of the Service Pro panel shall flash five times and then turn off. If commissioning is not performed, the telemetry features shall remain disabled, but all Singulair wastewater treatment system operating controls and diagnostic features shall be fully functional.

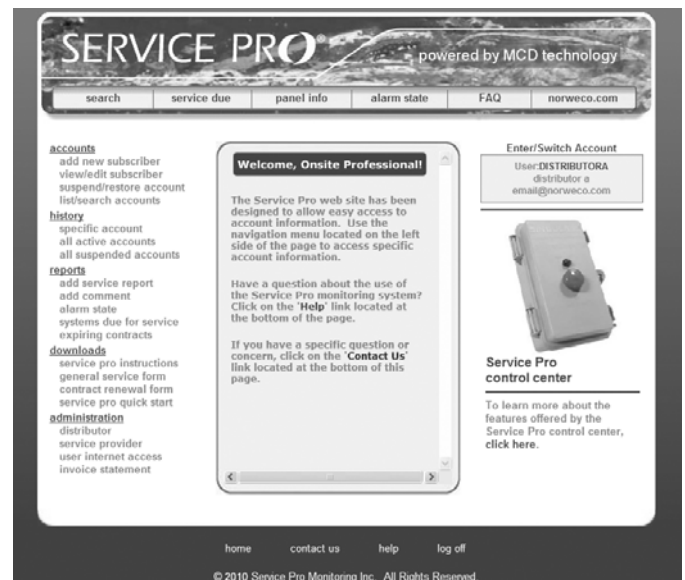

www.servicepromcd.com

SERVICE MANAGEMENT MODULE

All routine and emergency service shall be managed by the Service Pro monitoring center and shall be accessible through the password protected website. Systems where the telemetry functions are not activated shall be managed by manual entries into the website. When a Singulair installation is registered, the service frequency for the system shall be entered into the database. An online report shall constantly notify distributors and service providers of the systems that are due for service in the next 90 days, including both warranty and extended service contract inspections. All systems with service contracts expiring within the next 90 days in a given geographic area also shall be posted to an online report. Any system in the area that is currently experiencing an alarm condition shall be posted and viewable by the distributor and service provider. Distributors shall have the ability to grant regulatory officials access to system reports. These reports shall improve maintenance efficiency by allowing all service visits and installation inspections to be scheduled by date and grouped by physical proximity.

When service to the Singulair wastewater treatment system is performed, the date and time of the service visit as reported by the Service Pro telemetry system shall be posted on the website. If the telemetry system has not been commissioned, the website shall have the ability to receive manually entered service reports and post them with all inspection and compliance information. Manually completed service reports shall be automatically incorporated into the Service Pro website for electronic tracking. The service reports shall specify the inspection date, service performed and the condition of all equipment, including the Singulair aerator, Bio-Kinetic system, control center, optional disinfection system and effluent disposal system.

CERTIFICATION AND TESTING

The Service Pro control center shall be certified by internationally accredited, independent testing laboratories to verify product safety and performance. The control center shall meet the requirements of Underwriter's Laboratory (UL) Standard 508 and the Canadian Standards Association (CSA) Standard CAN/CSA-C22.2 No. 68-92 (R2004). The telemetry equipment shall be licensed by the Federal Communications Commission (FCC) under Standard 68. The circuit board shall be tested by an independent agency for certification and approval to ANSI C62-41 for 320 joules of intermittent electrical surge protection. The Service Pro control center shall be tested by an independent third party laboratory for electromagnetic compatibility per European Standard EN61000-6-1, including radiated and conducted radio frequency testing, electrostatic discharge testing and fast burst transient testing. To prevent corrosion from humidity or potentially harmful gasses associated with the treatment of domestic wastewater, the completed circuit board shall be conformal coated with a UL Recognized acrylic resin meeting military specification MIL-46058C.

The Service Pro control center shall be listed by NSF International and CSA for compliance with all applicable standards. The enclosure for the control center shall be certified as complying with NEMA standards for outdoor rated electrical enclosures. The current sensing circuit of the control center shall be tested to maintain accuracy to within 5% of the design parameters when operated in ambient temperatures from -20° to 160° Fahrenheit. The control center shall meet the requirements of NSF/ANSI Standard 40 and Standard 245 for use with Singulair wastewater treatment systems, including performance testing of the audible and visual alarms. Control centers not complying with applicable standards, certifications and testing have not been proven suitable for long term use and shall not be considered for this application.

WARRANTY PROGRAM

The manufacturer shall provide a three year limited warranty against defects in material and workmanship under normal use and service for each Service Pro control center with MCD technology. The warranty shall also cover any other Singulair components purchased from the manufacturer. The Singulair distributor shall provide warranty program details to the regulatory agency, contractor and customer as required.

EQUIPMENT MANUFACTURER

The equipment specified herein shall be the product of a manufacturer having a minimum of seven years experience in the construction of prefabricated wastewater treatment equipment and systems. Bids shall be prepared on the basis of the equipment and material specified herein for purposes of determining the low bid. This is not done, however, to eliminate other products or equipment of equal quality and efficiency. If equipment is to be substituted, approval of such substitution must be made prior to execution of any order. It is assumed that substitution will result in a reduction of cost to the contractor and that if accepted, these savings will be passed along by a reduction in the base bid.

PROGRESS THROUGH SERVICE SINCE 1906

norweco[®]

*Engineering the future of water
and wastewater treatment*

220 REPUBLIC STREET
NORWALK, OHIO, USA 44857-1156
TELEPHONE (419) 668-4471
FAX (419) 663-5440
www.norweco.com

DISTRIBUTED LOCALLY BY:

Norweco[®], Norweco.com[®], Singulair[®], Modulair[®], Travalair[®], Singulair Green[®], Ribbit Rivet[®], Hydro-Kinetic Bio-Film Reactor[®], Hydro-Kinetic[®], Evenair[®], Lift-Rail[®], Microsonic[®], Bio-Dynamic[®], Bio-Sanitizer[®], Bio-Neutralizer[®], Bio-Kinetic[®], Bio-Static[®], Bio-Gem[®], Bio-Max[®], Bio-Perc[®], Blue Crystal[®], Phos-4-Fade[®], Enviro-C[®], ClearCheck[®], ChemCheck[®], Tri-Max[®], Hydra-Max[®], Service Pro[®], MCD[®], TNT[®], Grease Buster[®] and "BUSTER" logo[®] are registered trademarks of Norwalk Wastewater Equipment Company, Inc.

©MMXIII NORWECO, INC.