

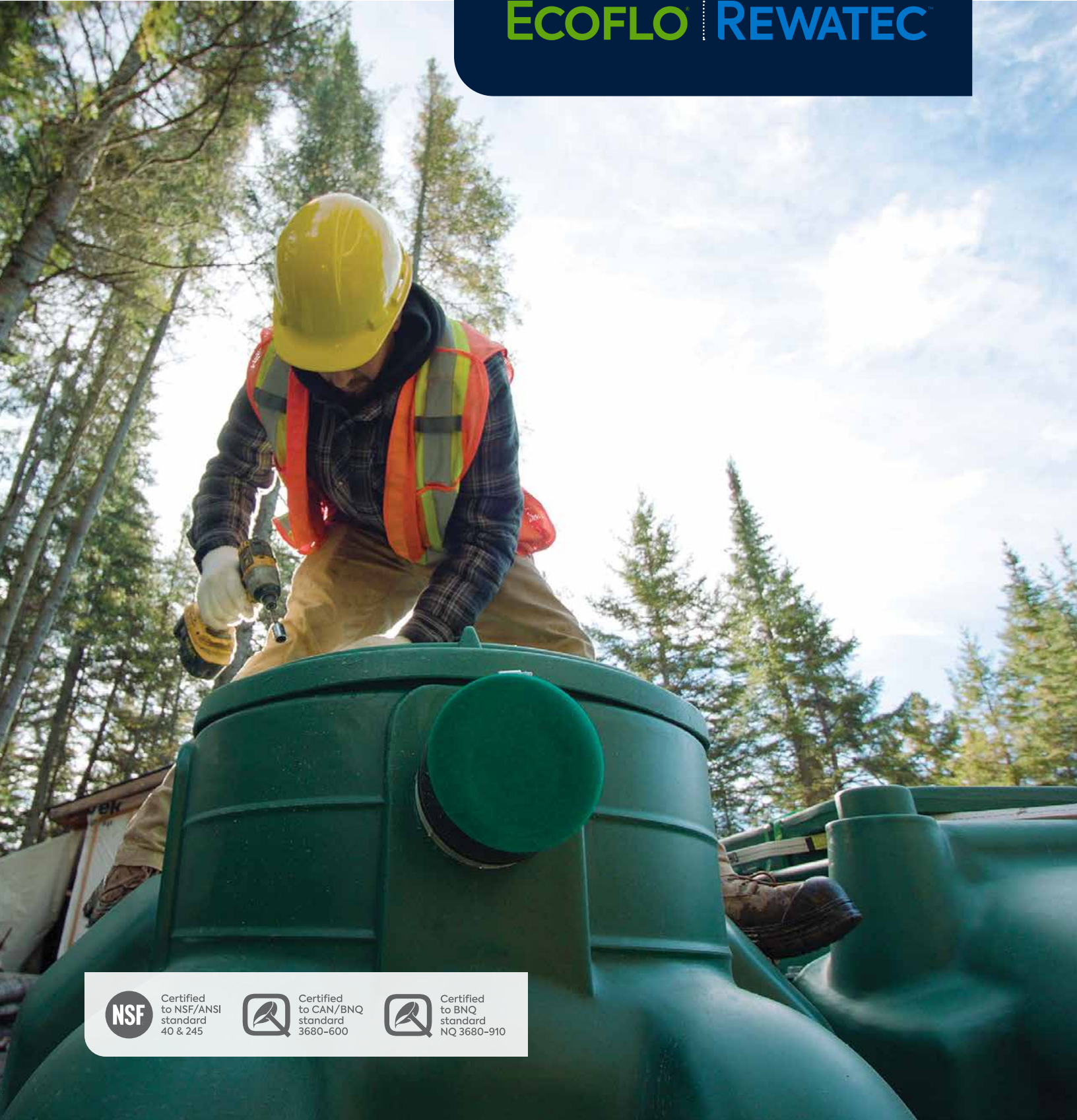

# Guide for professionals

**ECOFLO** | **REWATEC**



Certified to NSF/ANSI standard 40 & 245



Certified to CAN/BNQ standard 3680-600



Certified to BNQ standard NQ 3680-910

# People and Technologies making a difference

Premier Tech brings to life products that help feed, protect, and improve our world.

- **founded in 1923**
- **family business**
- **2,420 team members in North America**
- **4,700 team members worldwide**
- **24 manufacturing facilities in North America**
- **47 factories in 27 countries**



Through its Water and Environment business group, Premier Tech designs and manufactures sustainable local solutions for:

## wastewater treatment

residential

commercial



## rainwater harvesting



Together, we make green technologies accessible and continuously innovate to create solutions that last.

# Premier Tech's 360° support

Since 1995, professionals have been the heart of our business.

## IMMEDIATE ASSISTANCE

Experts available Monday to Friday to answer your field questions.



## IN-PERSON FIELD SUPPORT

Experts go on site when challenges cannot be resolved with a video call.



## ACCESSIBLE TRAINING

Online training programs make your installations as simple as possible.





## MOST COMPLETE WARRANTY IN THE INDUSTRY

Since 1995, we have proudly developed sustainable products with warranties that are clear and complete.



## AFTER-SALES SERVICE FROM THE MANUFACTURER

Largest network of local partners to maintain systems and honor warranties.



## PRO SPACE

Quickly find all the documents you need in one place.



## FULL CUSTOMER SUPPORT

Teams directly assist customers, so you can concentrate on your work.

# Ecoflo is how we make a sustainable difference. Together.

Join us in the movement to make the world a better, more sustainable place. Protect your client's property and the environment by recommending Ecoflo, the most eco-responsible septic system available.

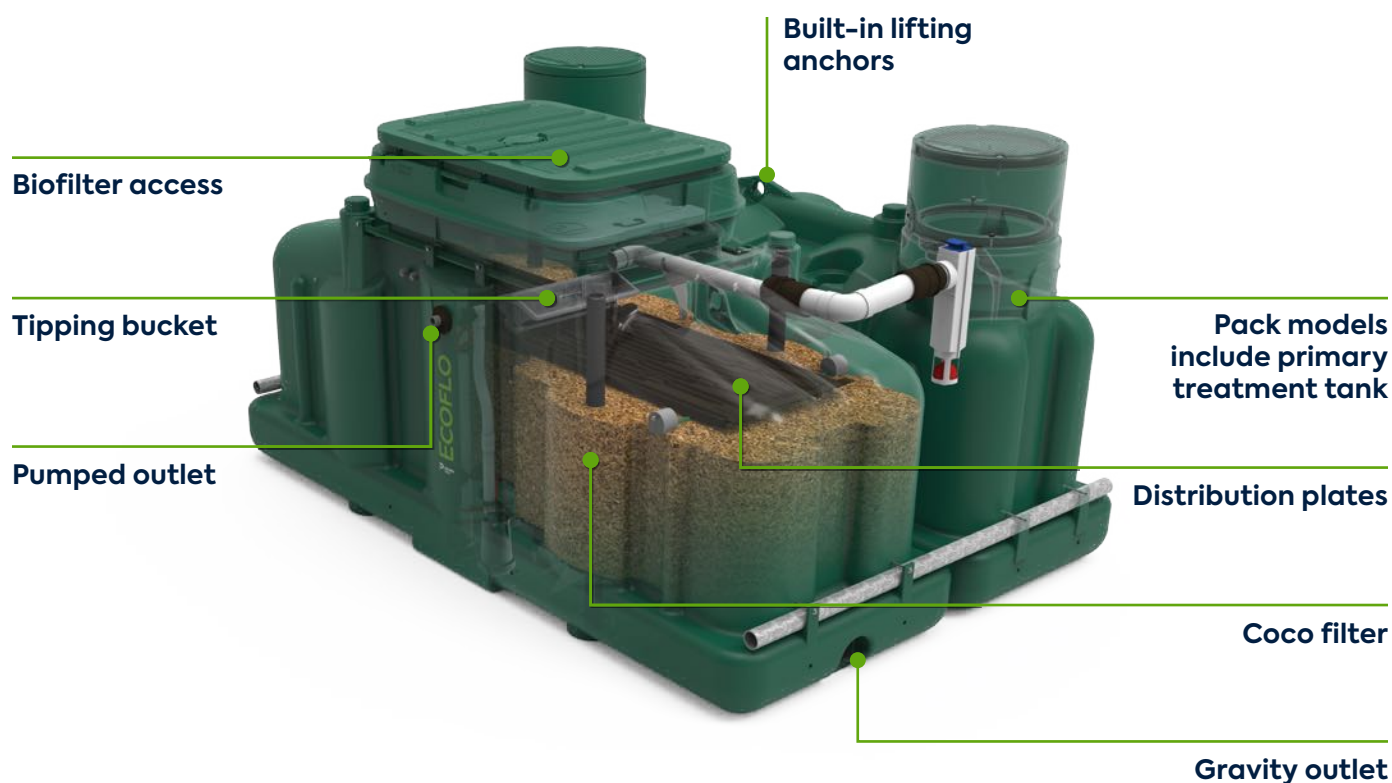

**THE #1 COMPACT FILTER CHOICE!**



**SEE HOW ECOFLO  
IS INSTALLED**  
[ECOFLO.LINK/YOUTUBE](https://www.ecoflo.com/YouTube)

## > QUICK INSTALLATION

- ready-to-use models
- easy-to-follow instructions
- can be installed in only one day

## > MODELS FOR ANY SITE

- options for all soil conditions
- pumped or gravity discharge
- compact models

## > PRODUCT AVAILABILITY

- 140 depots across North America
- quality-controlled inventory
- reliable order tracking

## > 10-YEAR TOTAL WARRANTY

- all treatment-related parts and labor
- proper functioning of the filtering medium and its treatment performance
- no clogging or excess sludge

## > ECOFLO OUTPERFORMS STANDARDS

(NSF/ANSI standard 40 and 245)

Parameter	Requirements*	Ecoflo Effluent†
<b>TSS</b>	< 25 mg/L	8 mg/L
<b>CBOD<sub>5</sub></b>	< 30 mg/L	6 mg/L
<b>Fecal coliforms</b>	No requirement	—

\* 30-day average.

† With 100% coconut husk fragment filtering medium.

“ Ecoflo is a can't-mess-it-up system that's super simple to install. All a contractor has to do is dig the hole, level the system, and be able to hook up the inlet and outlet pipes. That's it. ”

**Debbie Mayers**

Owner, Tri-State Pump & Septic Supply  
Franklin, New Jersey



# Ecoflo advantages for your clients

## NATURAL, RENEWABLE, COMPOSTABLE FILTER

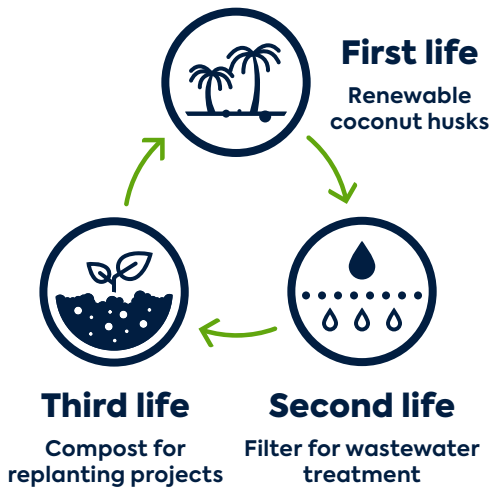

## LOWEST CARBON FOOTPRINT

From production and shipping to installation, maintenance, and usage, Ecoflo has the lowest carbon footprint of any product on the market.

### Total after 50-year life cycle

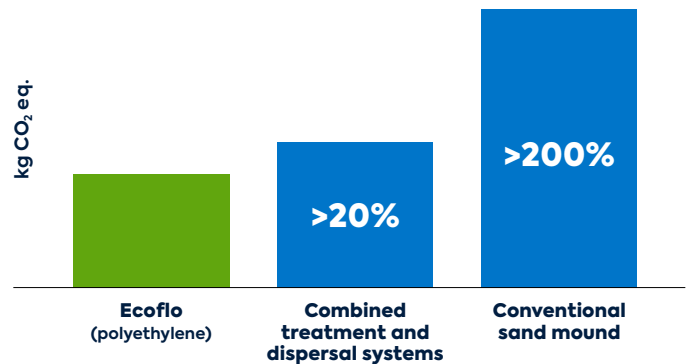

#### Notes

- Based on analysis of septic installations in Pennsylvania.
- Systems installed in soil with percolation rate of 60 mpi and rated for four bedrooms.
- Distances between installations and required materials assumed to be 40 miles for filtration sand and stone, 20 miles for backfill.
- Ecoflo installations include final dispersal to at-grade bed.

## INSTALLED FOR LIFE

- easy installation
- never needs to be moved or replaced
- never damages your client's landscaping

## PEACE-OF-MIND PERFORMANCE

- 24/7 autonomous operation
- never clogs your client's soil or contaminates their property
- worry-free warranty

## BEST LONG-TERM INVESTMENT

- maintains the selling value of your client's property
- no energy bills for wastewater treatment
- no high-priced repairs or hidden costs
- no full-system replacements





# A product supported by the manufacturer

## INFO-SHARING VISIT

After each installation, we visit new owners on site to teach them how Ecoflo works, answer their questions, and make sure their septic system is working perfectly.

## ANNUAL MAINTENANCE

We have a coast-to-coast network of partners, annually trained by us to maximize the life of your client's coco filter and protect their investment in their septic system.

- 15-point inspection
- coco filter aeration to promote healthy bacterial activity
- coco filter scarification to ensure optimal biofiltration

## FILTER REPLACEMENT

By having the coco filter in their Ecoflo biofilter replaced after 10 to 15 years, your client guarantees their system always protects their property and the environment.

- no excavation required
- no damage to your client's landscaping
- used coco filters are 100% compostable (unlike petroleum-based filtering media)



# ECOFLO<sup>®</sup>

## Polyethylene

### Solution for:

- 1,350 US gal/d maximum capacity
- simple and quick installations
- sites with limited space

### Advantages:

- install primary treatment tank and biofilter with one excavation\*
- compact and lightweight\*
- ready to use
- install in up to 2' of groundwater (pumped models only)
- one additional riser of 6" allowed (750 US gal/d models and below only)



\* PACK model

# ECOFLO<sup>®</sup>

## Concrete\*

### Solution for:

- 1,200 US gal/d maximum capacity
- all soil types
- all water tables

### Advantages:

- high-strength tank
- ready to use (select models only)
- install in groundwater up to the inlet pipe (pumped models only)
- one additional riser of 8" allowed



\* Check the availability of the product with your regional supervisor.

Refer to page 23 for technical information.

# REWATEC™

## Integrated UV disinfection (DiUV)

Our integrated DiUV option reliably kills wastewater pathogens, so you can safely send wastewater into a watercourse or ditch.

### Wi-Fi system

Sends us instant alerts, so we can help your client protect their investment and the environment. If there is a problem, a service team will follow up on it.

### Improved design

Strong, reliable parts ensure easy operation and maintenance.

### New UV lamp

Maximizes flow while lowering energy consumption.

### Integrated pump

Discharges treated wastewater in any site conditions and keeps ditch water out of the treatment unit.



## READY TO INSTALL

We make installation fast and simple by pre-assembling and pre-wiring our UV disinfection units.

## SOLUTIONS FOR ANY SITE

UV disinfection can be integrated in many polyethylene and concrete Ecoflo. It is also available in a separate tank.

## TREATMENT RESULTS

Parameter	BNQ* Effluent Standard	DiUV Effluent
<b>TSS</b>	< 15 mg/L	4 mg/L
<b>CBOD<sub>5</sub></b>	< 15 mg/L	4 mg/L
<b>Fecal coliforms</b>	< 20 CFU/100 mL <sup>†</sup>	< 2 CFU/100 mL <sup>†</sup>

\* Bureau de normalization du Québec certification, similar to NSF certification.

<sup>†</sup> Before photoreactivation.

## INTEGRATED UV MODELS

Models	Bedrooms
<b>2.8</b>	3
<b>3.4</b>	4
<b>4.1</b>	5

# REWATEC™

## UV disinfection (DiUV)

### CLASSIC UV DISINFECTION

#### INTEGRATED OR SEPARATE TANK

##### Quartz sleeve

Isolates UV lamp.

##### 70 W UV lamp

Exposes wastewater pathogens to UV radiation.

##### Stainless steel pipe

Holds wastewater for UV disinfection.

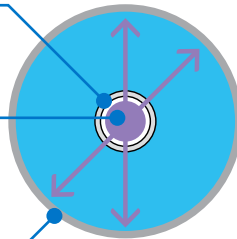

#### RECOMMENDED INFLUENT QUALITY

Parameter	Level
Iron	< 0.3 ppm (0.3 mg/L)
Manganese	< 0.05 ppm (0.05 mg/L)
Water hardness	< 7 gpg (120 mg/L)

### SELF-CLEANING UV DISINFECTION

#### SEPARATE TANK ONLY

##### Quartz sleeve

Holds wastewater for UV disinfection.

##### Stainless steel wiper blade

Cleans quartz sleeve six times per day.

##### 108 W UV lamps

Expose wastewater pathogens to UV radiation.

##### Elliptical reflectors

Reflect UV radiation to optimize the treatment process.

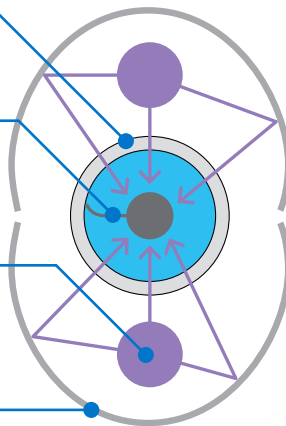

# REWATEC™

## Nitrogen reduction (ECDn)

Our nitrogen reduction option converts ammoniacal nitrogen into nitrogen gas, so you can safely discharge wastewater near ecologically sensitive areas.

### Septic tank (with baffle)

Captures solids and clarifies wastewater.

### Ecoflo

Filters wastewater through a coconut husk fragment filter. Converts ammoniacal and organic nitrogen into nitrates.

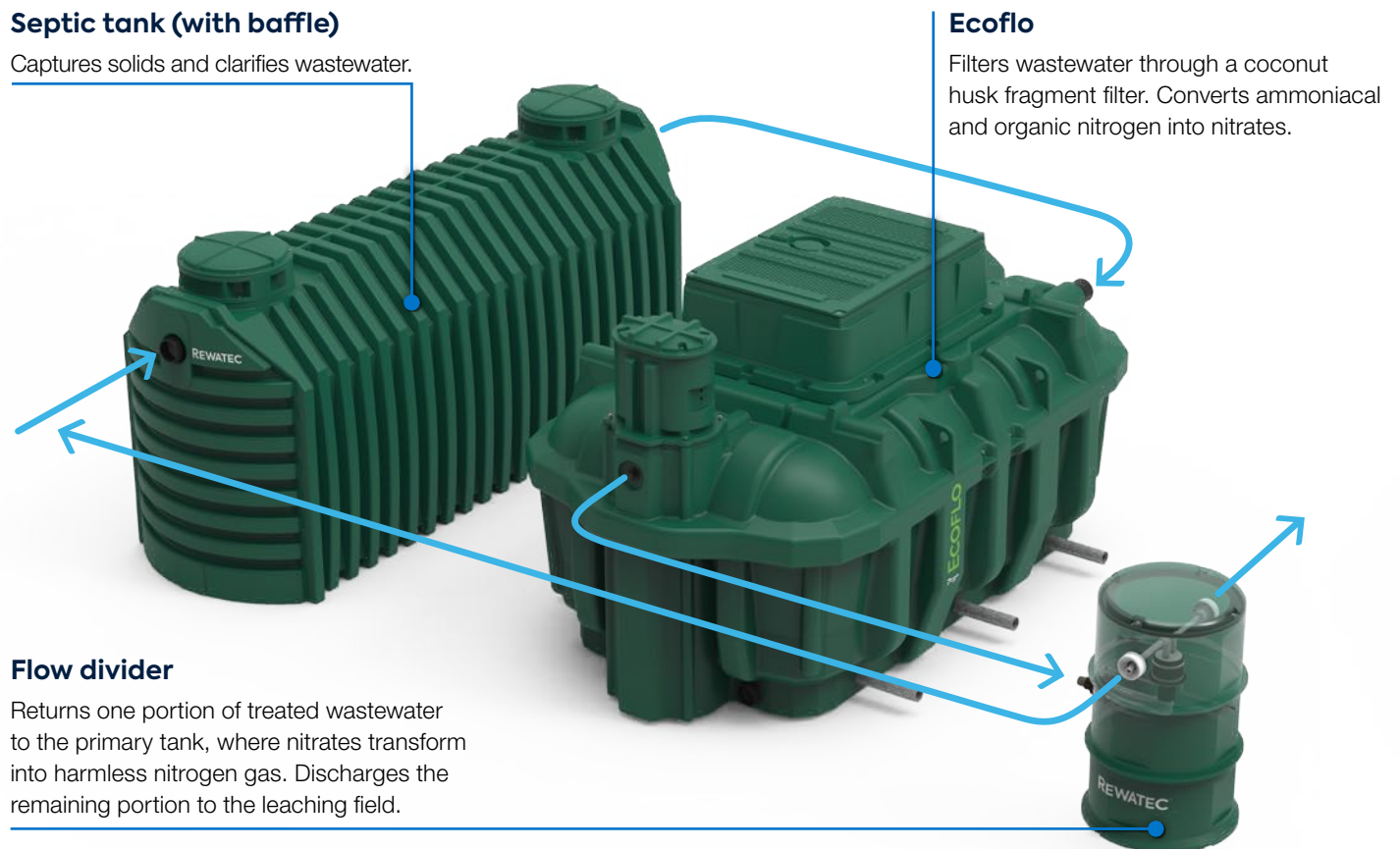

### Flow divider

Returns one portion of treated wastewater to the primary tank, where nitrates transform into harmless nitrogen gas. Discharges the remaining portion to the leaching field.

## COMPACT SIZE

Our nitrogen reduction option is ideal for sites with limited installation space.

## SOLUTIONS FOR ANY SITE

Nitrogen reduction is available with many polyethylene and concrete Ecoflo.

## TREATMENT RESULTS

Parameter	NSF Effluent Standard	ECDn Effluent
TSS	< 30 mg/L	2 ± 2 mg/L
CBOD <sub>5</sub>	< 25 mg/L	4 ± 3 mg/L
Total nitrogen reduction	> 50%	54%
pH	6 to 9	7.1

Refer to page 24 for technical information.

# REWATEC™

## Phosphorus removal (DpEC)

Without proper treatment, phosphorus in wastewater can cause harmful algae growth in lakes and rivers. Protect these sensitive areas with our phosphorus removal option.

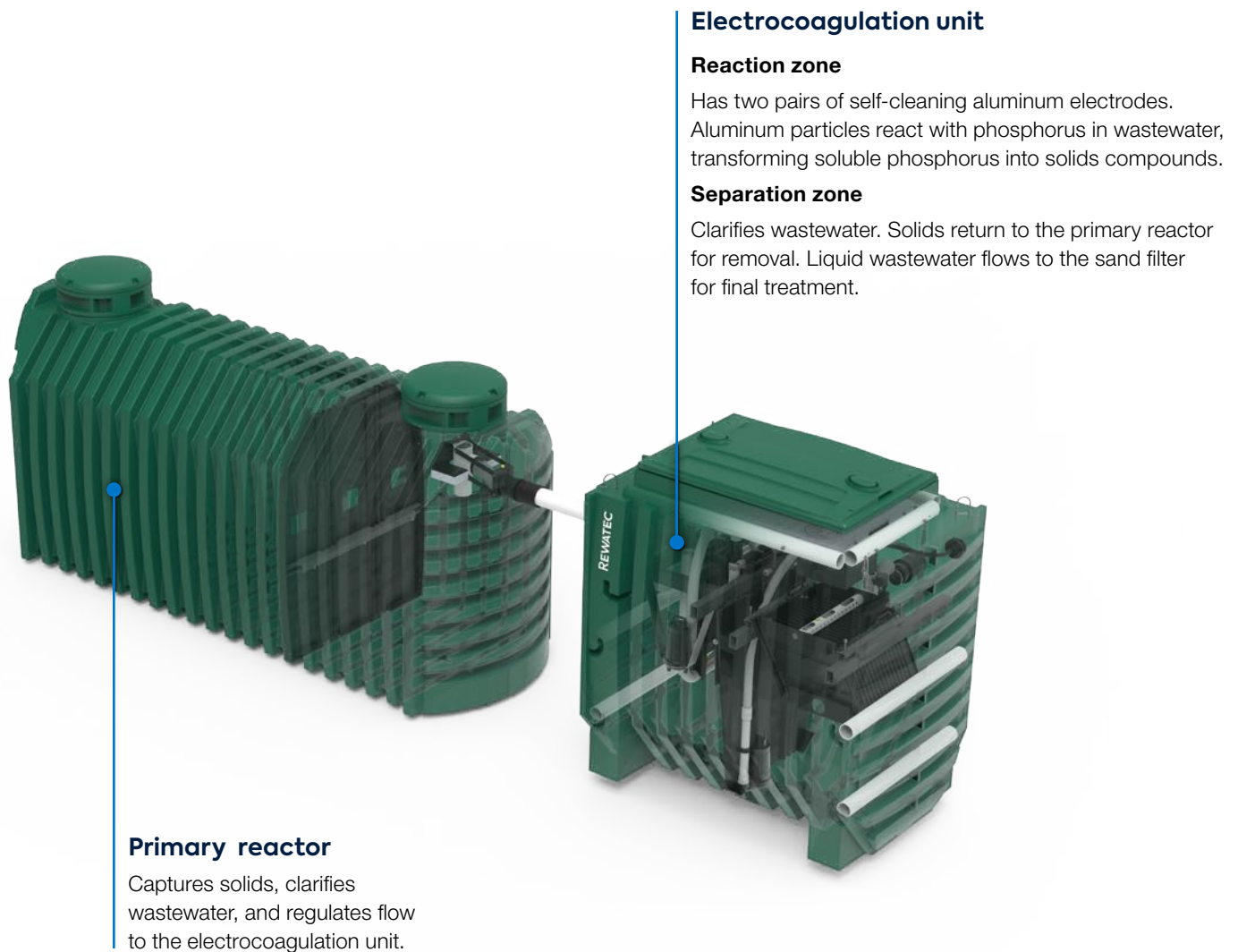

## SURFACE DISCHARGE NEAR LAKES

Phosphorus removal preserves water quality in sensitive environments.

# REWATEC™

## Components and accessories

### SEPTIC TANKS

- up to 1,760 US gal total nominal capacity
- high-strength polyethylene

Refer to page 25  
for technical information.



### PUMPING STATIONS

- up to 67 US gal effective dosing volume
- high-strength polyethylene

Refer to page 26  
for technical information.



### PUMPS

- up to 0.5 hp
- reliable and durable

Refer to page 26  
for technical information.



### FLOW DIVIDERS

- pressurized or gravity flow
- two to 10 outlets



### RISERS

- from 6" to 14"







# Product specifications

# Product line

<div style="text-align: center;"> <h2 style="color: green; margin: 0;">ECOFLO<sup>®</sup></h2> </div>			<div style="display: flex; justify-content: space-between; align-items: center;"> </div> <b>SPECIALIZED TREATMENT OPTIONS</b>		
			Integrated UV disinfection (DiUV)	UV disinfection (DiUV) in separate tank	Nitrogen reduction (ECDn)
Hydraulic Capacity	Size	Model			
<b>POLYETHYLENE</b>					
500 US gal/d	2.8	EC7-500-P-G/P	✓	✓	See page 24
		EC7-500-P-G/P-PACK	✓	✓	
600 US gal/d	3.4	EC7-600-P-G/P	✓	✓	
		EC7-600-P-G/P-PACK	✓	✓	
750 US gal/d	4.1	EC7-750-P-G/P	✓	✓	
		EC7-750-P-G/P-PACK	✓	✓	
1,050 US gal/d	5.7	EC7-1050-P-G/P	✗	✓	
1,350 US gal/d	7.3	EC7-1350-P-G/P	✗	✓	
<b>CONCRETE</b>					
500 US gal/d	2.8	EC7-500-C-GDV/PDV	✓	✓	See page 24
750 US gal/d	4.1	EC7-750-C-GDV/PDV	✓*	✓	
1,200 US gal/d	6.5	EC7-1200-C-G/P-H2+3	✗	✓	

\* Check the availability of the product with your regional supervisor.

## NEED HELP?

For help choosing the right Ecoflo model, specialized treatment options, and accessories, call our expert in your area. You'll get free, professional advice to transform any challenge into a custom-made septic solution.

**+1 800 632-6356**

# Recommended distances

We recommend the following distances guidelines. Failure to abide by these guidelines may void the warranty of the installation.

Reference Points	Polyethylene		Concrete
	2.8, 3.4, 4.1	5.7, 7.3	
Base of excess backfill, slopes, or embankments vs. biofilter lid	<b>A</b>	13'	10'
Parking area vs. biofilter lid	<b>B</b>	13'	10'
Object or structure weighing more than 500 lb (225 kg) vs. biofilter lid	<b>C</b>	13'	10'
Retaining wall vs. biofilter lid	<b>D</b>	13'	10'
Finished landscaping vs. base of biofilter lid	<b>E</b>	2"	
Seasonal high groundwater table (SHGT) vs. base of <a href="#">gravity-discharge unit</a>	Do not install in groundwater		
Seasonal high groundwater table (SHGT) vs. base of <a href="#">pumped-discharge unit</a>	<b>Fp</b>	2'	Do not install in groundwater Up to bottom of inlet pipe

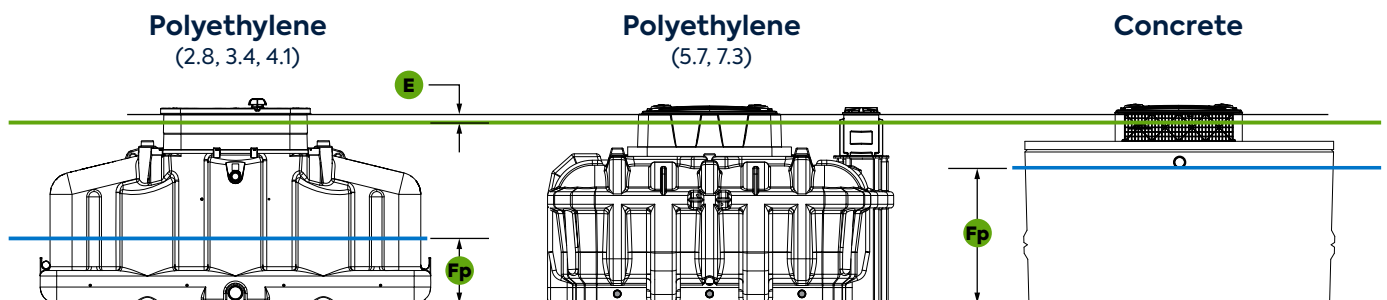
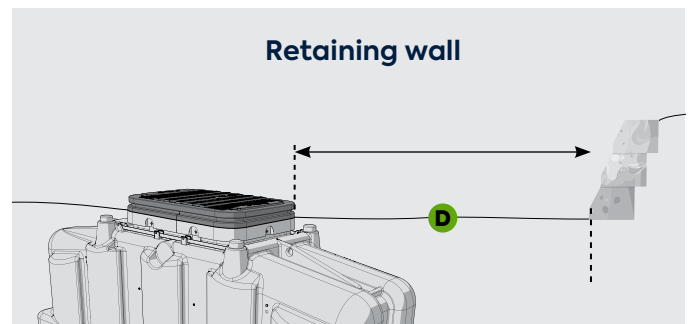
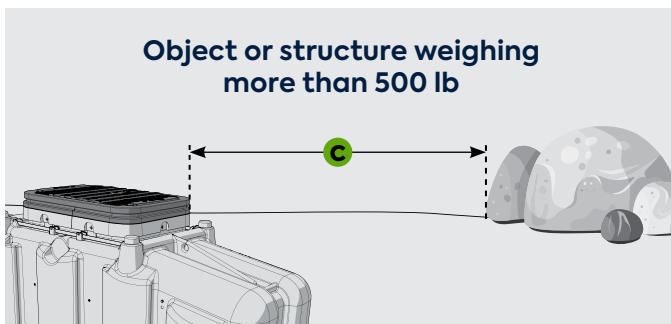
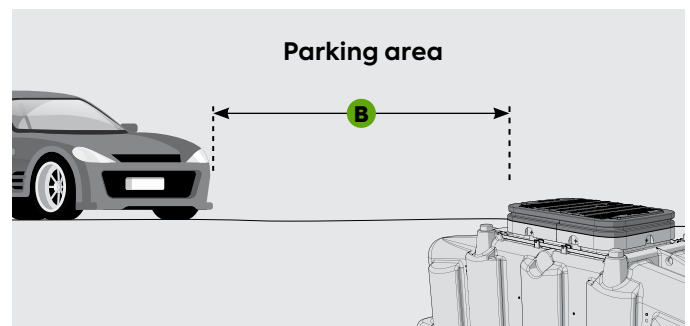
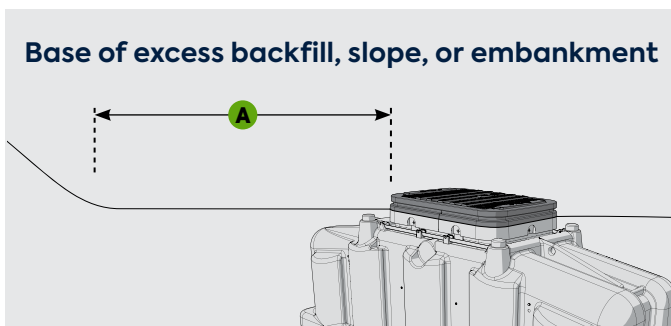

Legend: — Finished landscaping — SHGT

# ECOFLO<sup>®</sup>

## Polyethylene • PACK



	2.8	3.4	4.1
	EC7-500-P-G/P-PACK	EC7-600-P-G/P-PACK	EC7-750-P-G/P-PACK
<b>Hydraulic capacity</b>	500 US gal/d	600 US gal/d	750 US gal/d
<b>Primary tank volume</b>	800 US gal	1,000 US gal	1,250 US gal
<b>Length</b> <span style="color: green;">A</span>	10' 3"	11' 8"	13' 3-1/2"
<b>Width</b> <span style="color: green;">B</span>	8' 2"		
<b>Height</b> <span style="color: green;">C</span> Includes 12" of risers	5' 9-1/2"		
<b>Inlet height of primary tank from bottom</b> <span style="color: green;">D</span>	4' 2-1/2"		
<b>Gravity water outlet height</b> <span style="color: green;">Eg</span>	1-3/4"		
<b>Pumped water outlet height</b> <span style="color: green;">Ep</span>	3' 8-7/8"		
<b>Riser height allowed</b>	6		
<b>Weight</b> Includes internal components and coco filter	1,675 lb	1,870 lb	2,090 lb
<b>Built-in effective volume available for dosing</b> Pumped discharge models only	160 US gal	180 US gal	200 US gal
<b>Emergency storage above alarm float</b>	545 US gal	665 US gal	760 US gal

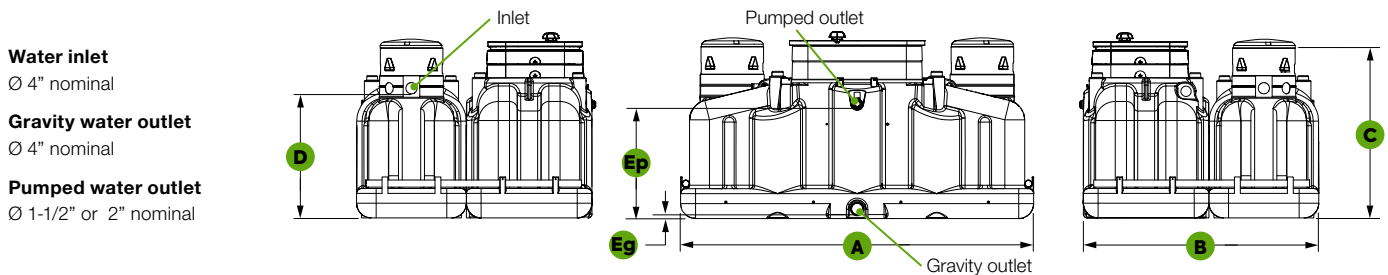

## TYPICAL INSTALLATIONS

Gravity discharge to leaching field

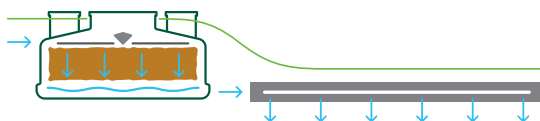

Pumped discharge to leaching field

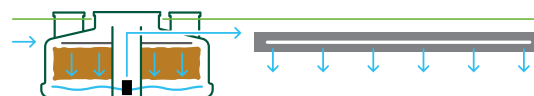

# ECOFLO<sup>®</sup>

## Polyethylene



	2.8	3.4	4.1
	EC7-500-P-G/P	EC7-600-P-G/P	EC7-750-P-G/PDV
<b>Hydraulic capacity</b>	500 US gal/d	600 US gal/d	750 US gal/d
<b>Length</b> <span style="float: right;">A</span>	10' 3"	11' 8"	13' 3-1/2"
<b>Width</b> <span style="float: right;">B</span>	4' 2-3/8"		
<b>Height</b> <span style="float: right;">C</span> <small>Includes 12" of risers</small>	5' 9-1/2"		
<b>Inlet height from bottom</b> <span style="float: right;">D</span>	4' 1/2"		
<b>Gravity water outlet height</b> <span style="float: right;">Eg</span>	1-3/4"		
<b>Pumped water outlet height</b> <span style="float: right;">Ep</span>	3' 8-7/8"		
<b>Riser height allowed</b>	6"		
<b>Weight</b> <small>Includes internal components and coco filter</small>	1,235 lb	1,345 lb	1,455 lb
<b>Built-in effective volume available for dosing</b> <small>Pumped discharge models only</small>	160 US gal	180 US gal	200 US gal
<b>Emergency storage above alarm float</b>	545 US ga	665 US gal	760 US gal

**Water inlet**  
Ø 4" nominal

**Gravity water outlet**  
Ø 4" nominal

**Pumped water outlet**  
Ø 1-1/2" or 2" nominal

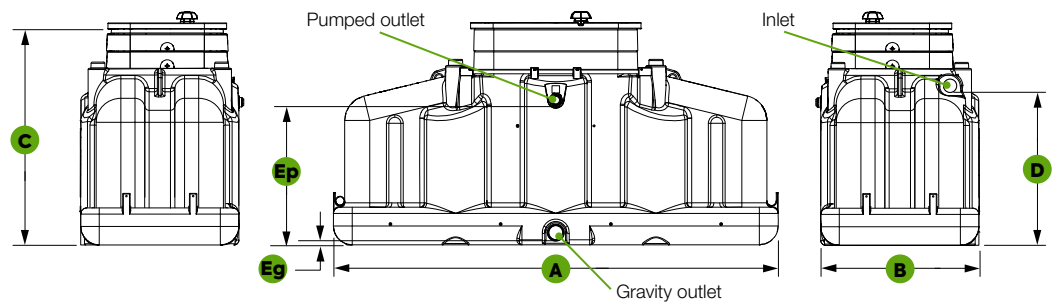

## TYPICAL INSTALLATIONS

Gravity discharge to leaching field

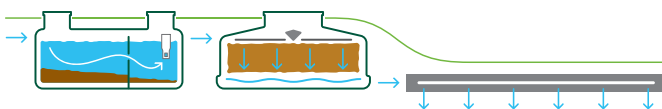

Pumped discharge to leaching field

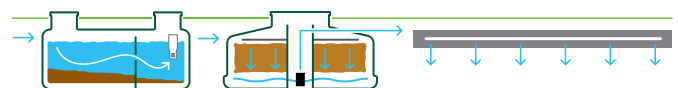

# ECOFLO<sup>®</sup>

## Polyethylene



	5.7	7.3
	EC7-1050-P-G/PDV	EC7-1350-P-G/PDV
<b>Hydraulic capacity</b>	1,050 US gal/d	1,350 US gal/d
<b>Length</b> <span style="float: right;">A</span>	11' 1"	13' 7"
<b>Width</b> <span style="float: right;">B</span>	6' 7" (2,000 mm)	6' 9"
<b>Height</b> <span style="float: right;">C</span>	6' 1/2"	
<b>Inlet height from bottom</b> <span style="float: right;">D</span>	4' 1-1/2"	
<b>Gravity water outlet height</b> <span style="float: right;">Eg</span>	3"	
<b>Pumped water outlet height</b> <span style="float: right;">Ep</span>	4' 1"	
<b>Riser height allowed</b>	No additional risers allowed	
<b>Weight</b> <small>Includes internal components and coco filter</small>	2,640 lb	3,120 lb
<b>Built-in effective volume available for dosing</b> <small>Pumped discharge models only</small>	230 US gal	295 US gal
<b>Total emergency storage capacity</b>	1,155 US gal	1,595 US gal

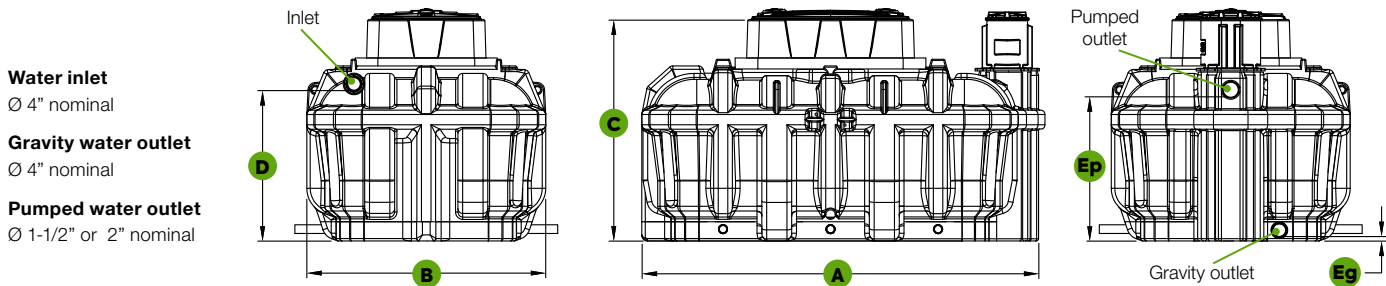

## TYPICAL INSTALLATIONS

Gravity discharge to leaching field

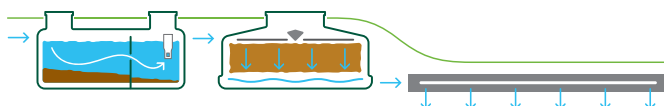

Pumped discharge to leaching field

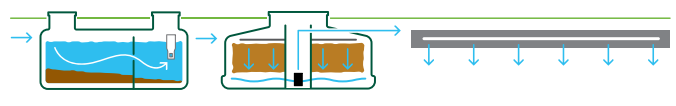

# ECOFLO<sup>®</sup>

## Concrete



	2.8	4.1	6.5
	EC7-500-C-GDV/PDV	EC7-750-C-GDV/PDV	EC7-1200-C-G/P-H2+3
<b>Hydraulic capacity</b>	500 US gal/d	750 US gal/d	1,200 US gal/d
<b>Length</b> <span style="color: green;">A</span>	10'	12' 7"	12' 7"
<b>Width</b> <span style="color: green;">B</span>	4' 2"	4' 5"	6' 10"
<b>Height</b> <span style="color: green;">C</span>	6' 7"	6' 9"	6' 11"
<b>Inlet height from bottom</b> <span style="color: green;">D</span>	4' 6"	4' 10"	4' 11"
<b>Gravity water outlet height</b> <span style="color: green;">Eg</span>	4"	5"	6"
<b>Pumped water outlet height</b> <span style="color: green;">Ep</span>	4' 3-1/2"	5'	4' 11"
<b>Riser height allowed</b>	8"		
<b>Weight</b> Includes tank, upper slab, internal components, and coco filter	9,900 lb	15,840 lb	19,520 lb
<b>Built-in effective volume available for dosing</b> Pumped discharge models only	150 US gal	200 US gal	220 US gal
<b>Emergency storage above alarm float</b>	500 US gal	750 US gal	1,360 US gal

**Water inlet**  
Ø 4" nominal

**Gravity water outlet**  
Ø 4" nominal

**Pumped water outlet**  
Ø 1-1/2" or 2" nominal

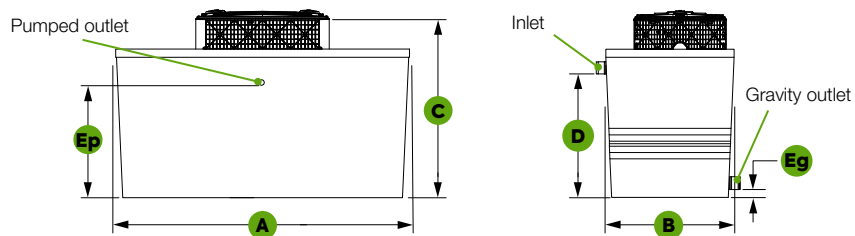

## TYPICAL INSTALLATIONS

Gravity discharge to leaching field

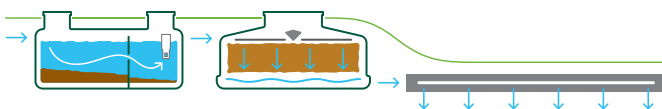

Pumped discharge to leaching field

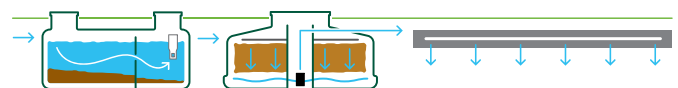

# REWATEC™

## Nitrogen reduction (ECDn)

### TYPICAL INSTALLATION

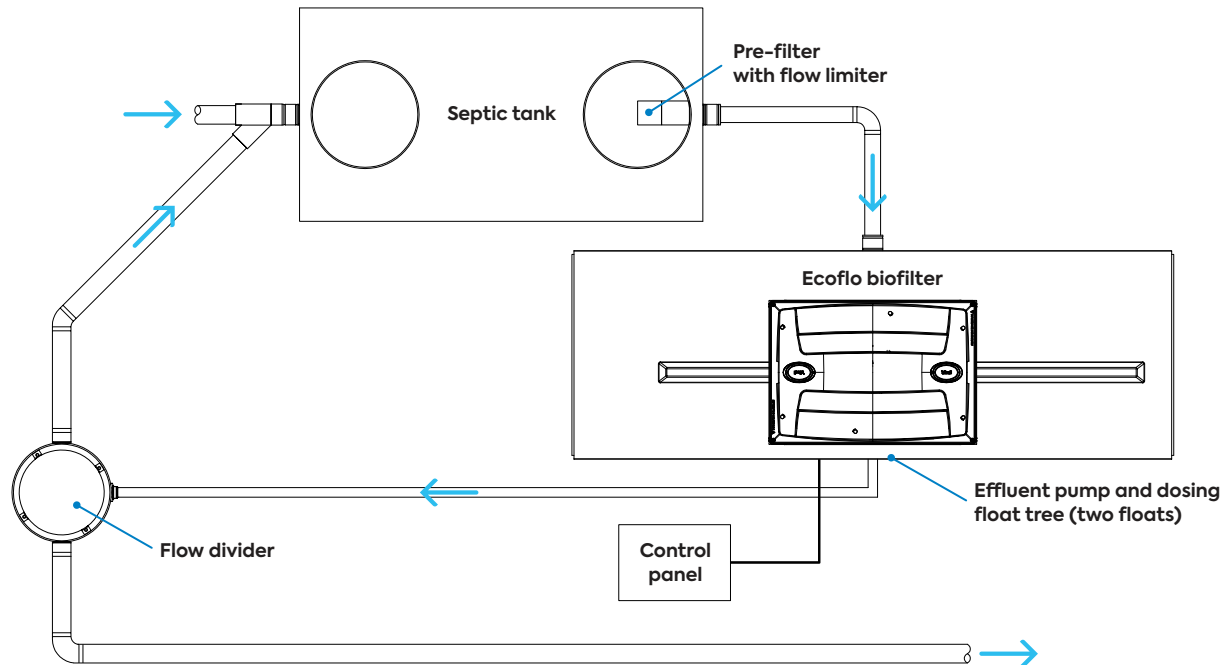

### ECOFLO COMPATIBILITY

#### Polyethylene

Hydraulic Capacity	Size	Model
500 US gal/d	3.4	ECDN-500-P
600 US gal/d	4.1	ECDN-600-P
		ECDN-600-P-PACK
865 US gal/d	5.7	ECDN-865-P
1,100 US gal/d	7.3	ECDN-1100-P

#### Concrete

Hydraulic Capacity	Size	Model
600 US gal/d	4.1	ECDN-600-C
1,000 US gal/d	6.5	ECDN-1000-C



# REWATEC™

## Septic and holding tanks



	Septic Tanks with Effluent Filter						Holding Tanks*
	PST-280	PST-340	PST-390	PST-420	PST-500	PST-660	PHT-660
<b>Total nominal capacity</b>	740 US gal	900 US gal	1,030 US gal	1,140 US gal	1,270 US gal	1,760 US gal	1,760 US gal
<b>Liquid capacity</b>	600 US gal	800 US gal	880 US gal	950 US gal	1,080 US gal	1,530 US gal	1,550 US gal
<b>Length</b> <span style="color:blue">A</span>	8' 2"	9' 11-1/2"	10' 10-1/2"	12' 4-3/4"	9' 7"	13'	13'
<b>Width</b> <span style="color:blue">B</span>	4' 1-1/4"			4' 4-3/8"			4' 4-3/8"
<b>Height</b> <span style="color:blue">C</span>	4' 4-3/8"			5' 7-3/4"			6' 2-3/8"
<b>Inlet height</b> <span style="color:blue">D</span>	3' 5-1/2"			4' 7-1/8"			4' 7-1/8"
<b>Outlet height</b> <span style="color:blue">E</span>	3' 2-1/2"			4' 4"			
<b>Openings diameter</b> <span style="color:blue">F</span>	1' 6-1/2"						
<b>Weight</b>	353 lb	397 lb	419 lb	529 lb	584 lb	717 lb	772 lb
<b>Certification</b>	BNQ/CSA			CSA	BNQ/CSA		CSA

\* Certified for certain applications by Health Canada's Health Products and Food Branch.

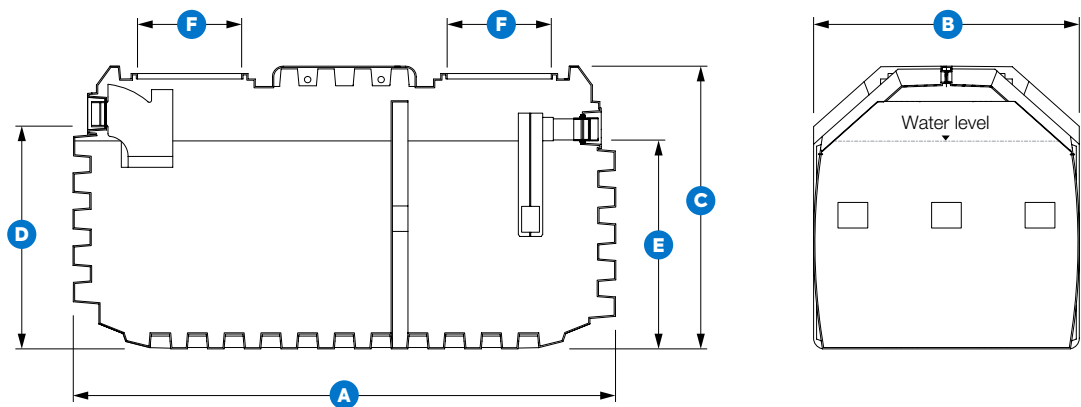

# REWATEC™

## Pumping stations



	PSA-240	PSA-240H
<b>Pump</b>	120 V	
<b>Float</b>	On/off pump switch and alarm switch	
<b>Length of base</b> <span style="color: blue;">A</span>	3' 1-1/2"	
<b>Width of base</b> <span style="color: blue;">B</span>	2' 10"	
<b>Height</b> <span style="color: blue;">C</span>	4' 2"	5' 4"
<b>Inlet height</b> <span style="color: blue;">D</span>	2' 1"	3' 5-3/4"
<b>Outlet height</b> <span style="color: blue;">E</span>	3' 4"	
<b>Riser height allowed</b>	2' 4"	
<b>Weight</b>	110 lb	123 lb
<b>Effective dosing volume</b>	40 US gal	67 US gal
<b>Total volume</b> At water inlet level	63 US gal	106 US gal

**Water inlet**

Ø 4" nominal

**Water outlet**

Ø 1-1/2" or 2" nominal

**Air flow**

Ø 4" nominal

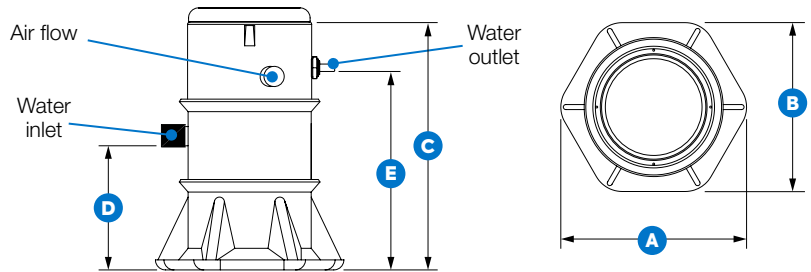

## Pumps

### PERFORMANCE CURVE

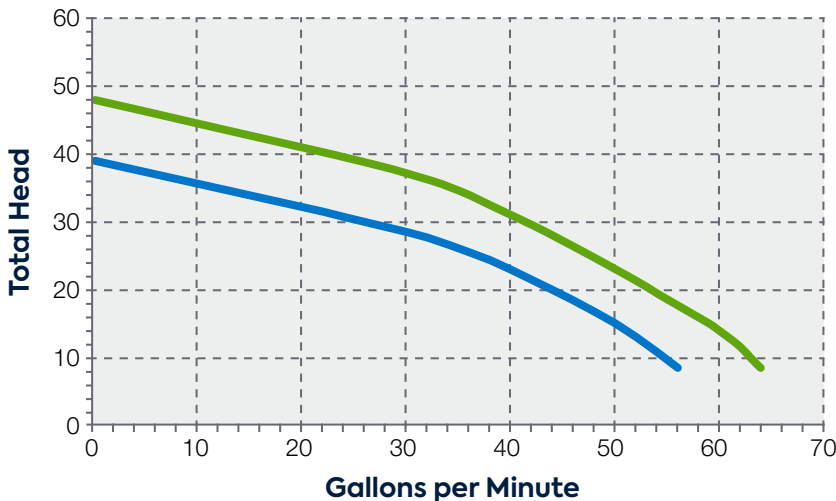

**Legend**

- Champion 0.5 hp pump (with Ecoflo)  
8.5 A, 1 phase, 60 Hz, 115 V
- Champion 0.4 hp pump (with integrated DiUV)  
6.6 A, 1 phase, 60 Hz, 115 V

# Float adjustments

The dose given by the on/off float depends on the length of the float stem, the length of the stem sleeve, and the position of the rubber stopper.

The factory setting will give the minimum dose. To customize the setting to accommodate local regulations or on-site requirements:

- cut a section of the stem sleeve
- lower the rubber stopper along the stem

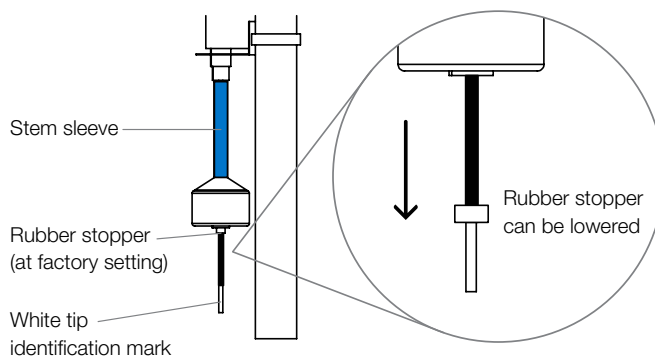

## POLYETHYLENE

Desired Dose Volume					Adjustment	Final Sleeve Length
2.8 – 500	3.4 – 600	4.1 – 750	5.7 – 1050	7.3 – 1350		
21 US gal	24 US gal	26 US gal	20 US gal		None (factory setting)	4-1/2"
22 US gal	30 US gal	35 US gal	30 US gal	40 US gal	Lower rubber stopper <b>1/4"</b> along stem	4-1/2"
80 US gal	95 US gal	100 US gal	85 US gal	115 US gal	Lower rubber stopper <b>2-1/2"</b> along stem*	4-1/2"
105 US gal	120 US gal	130 US gal	110 US gal	155 US gal	Cut 1" off sleeve and lower rubber stopper <b>2-1/2"</b> along stem*	3-1/2"
130 US gal	150 US gal	165 US gal	140 US gal	195 US gal	Cut 2" off sleeve and lower rubber stopper <b>2-1/2"</b> along stem*	2-1/2"
160 US gal	180 US gal	200 US gal	175 US gal	235 US gal	Cut 3" off sleeve and lower rubber stopper <b>2-1/2"</b> along stem*	1-1/2"
			230 US gal	295 US gal	Remove sleeve and lower rubber stopper <b>2-1/2"</b> along stem*	0"

\* Or until identification mark.

## CONCRETE

Desired Dose Volume		Adjustment	Final Sleeve Length
2.8 – 500	4.1 – 750		
20 US gal	20 US gal	None (factory setting)	4-1/2"
70 US gal	95 US gal	Lower rubber stopper <b>2-1/4"</b> along stem	4-1/2"
90 US gal	120 US gal	Cut 1" off sleeve and lower rubber stopper <b>2-1/4"</b> along stem*	3-1/2"
110 US gal	140 US gal	Cut 2" off sleeve and lower rubber stopper <b>2-1/4"</b> along stem*	2-1/2"
125 US gal	170 US gal	Cut 3" off sleeve and lower rubber stopper <b>2-1/4"</b> along stem*	1-1/2"
150 US gal	200 US gal	Remove sleeve and lower rubber stopper <b>2-1/4"</b> along stem*	0"

Desired Dose Volume	Adjustment	Final Sleeve Length
6.5 – 1200		
95 US gal	None (factory setting)	3-1/2"
130 US gal	Cut 1" off sleeve and lower rubber stopper <b>2-1/2"</b> along stem*	2-1/2"
165 US gal	Cut 2" off sleeve and lower rubber stopper <b>2-1/2"</b> along stem*	1-1/2"
200 US gal	Cut 3" off sleeve and lower rubber stopper <b>2-1/2"</b> along stem*	1/2"
220 US gal	Remove sleeve and lower rubber stopper <b>2-1/2"</b> along stem*	0"

\* Or until identification mark.



# Premier Tech's 360° support

- exclusive and innovative service offer
- phone or interactive video assistance
- real-time diagnostics
- field support when necessary
- accessible training
- Pro Space dedicated to professionals

## SALES AND SERVICES

+1 800 632-6356  
[info.ptwe.na@premiertech.com](mailto:info.ptwe.na@premiertech.com)

## ORDERS

+1 800 632-6356, ext. 16733  
[orders.ptwe.na@premiertech.com](mailto:orders.ptwe.na@premiertech.com)

## CREDIT

+1 800 632-6356, ext. 16034  
[credit.ptwe.na@premiertech.com](mailto:credit.ptwe.na@premiertech.com)

## Making a difference for water and the environment

At Premier Tech, People and Technologies connect in lasting, transformative ways, giving life to products and services that help feed, protect, and improve our world.

Our team of experts constantly innovates, redefining what is possible through effective, efficient, and sustainable solutions. Driven by a shared passion, we are committed to protecting our resources for the future.



### PT Water and Environment

+1 800 632-6356  
[info.ptwe.na@premiertech.com](mailto:info.ptwe.na@premiertech.com)  
[PT-WaterEnvironment.com](http://PT-WaterEnvironment.com)



The information contained in this document was up-to-date and consistent with the information available at the time of publication. Premier Tech Ltd. makes no warranties or representations as to its accuracy. Because of its continuous improvement policy, Premier Tech Ltd. and its affiliated companies reserve the right to change and/or discontinue the manufacture of any product and/or modify technical data and prices, for any reason whatsoever and at its sole discretion, without further notice and without liability to anyone in this regard. ECOFLO®, REWATEC™, PREMIER TECH®, and PREMIER TECH & DESIGN™ are trademarks of Premier Tech Ltd. or its affiliates. Ecoflo® is protected under patents: CA2499637; US7097768; ES2285173; EP1539325 (BE, FR). Notice issued on 2019-01-11. For current data regarding all patent application(s) and patent(s) for this product or any part thereof, consult the website [patentmarking.premiertech.com](http://patentmarking.premiertech.com) (reference: 3685).

© 2021 Premier Tech Ltd. All rights reserved.  
 Printed in Canada

USA  
 20211025