

# Lath Inspection Resource Manual

Second Edition



Developed and Distributed by the Minnesota Lath & Plaster Bureau

# Table of Contents

Disclaimer.....	Page 3	Installing Water-Resistive Barriers.....	12
Acknowledgements.....	3	General	
Introduction.....	3	Pipe and Vent Sleeves	
Some Lathing and Stuccoing Terminology...4-5		Isolating Devices	
Additional Resources.....	6	Weep Screed	
ASTM Standards		Expounding on Expanded Metal Lath....	13-14
Some Laths Used in Stucco Applications.....7		Proper Orientation of Lath	
Expanded Metal Lath		Lath Attachment.....	14-15
Self Furring Lath		Wood Framing	
Paper Backed Lath		Metal Framing	
Woven Wire Lath		Concrete and Concrete Block	
Welded Wire Lath		Proposed New Rule Change	
Ribbed Lath		Lath Attachment with Stub Nails	
Lathing Accessories.....	8-9	Control and Expansion Joints.....	16-20
Casing Beads & Stops		Differences Between	
Weep Screeds		Residential Construction	
Corner Beads		Proposed New Rule Change	
Corner Aids		Stopping Lath at Control Jts.	
Control Joints		Control Joint Wall Areas	
“M” Joint		Control Joint Intersections	
“J Type” Joint		CJ at Floor line Expansion	
Inside Corner Joint		Abutting Joints at Corners	
Galvanized vs. Zinc		Abutting Control Joints	
Expansion Joints		CJ abutting Weep Screed	
No. 40 Joint		Dissimilar Materials	
Casing Bead Joint		#40 Expansion Joint	
Other Lathing Accessories.....	10	Casing Bead Expansion Jt.	
Reentrant Corners		Weeping Expansion Joint	
Strip Lath		Lath and Accessories at Windows.....	20-21
Corner Lath		Casing Bead at Window	
Reveals		CJ at Window Head Corner	
Channel Screeds		CJ at Window Sill Corner	
Metals and Plastics		Some Typical Installation Details.....	21-22
Tie Wire		Abutting Casing Beads	
Substrates and Weather-Resistive Barriers.....	11	Outside Corner Aid	
Gypsum Sheathing		Outside Corner Bead	
Fiberglass Mat Faced Gypsum Sthg.		Inside Corner Lath	
Wood Based Sheathing		Roof Line.....	22-23
Concrete and Concrete Masonry		Parapet at Membrane Roof	
Alternatives to ASTM D 226 Felt		Parapet/ Wall Intersection	
Alternatives to Grade D Building Paper		Fascia/ Soffit Weep	
Applicable Code References		Soffit Vent/ Weep Screed	
Proposed New Rule Change		General Notes.....	24
Applicable ASTM Standards		Code Rule Changes.....	25
Available Evaluation Reports			

# Disclaimer

The text, pictures and related notes contained herein are typical of stucco installations in Minnesota. Please see the 2007 Minnesota State Building Code for specific requirements. Examples illustrated are not called out in the code in all cases.

This guide contains general information on stucco installation and related materials. It is provided as a guide only and is not intended for any specific construction project. The Minnesota Lath and Plaster Bureau makes no express or implied warranty or guarantee of the techniques, construction methods, materials and details identified herein, nor does it assume any liability for the use of this information.

It is the sole responsibility of any building official, architectural or construction industry professional to apply their professional knowledge in utilizing the information contained in this publication.

Reproduction of this material is not permitted without the expressed written permission of the Minnesota Lath and Plaster Bureau. ©Copyright Minnesota Lath & Plaster Bureau, March 2009.

---

## Acknowledgements

*References to ASTM, ASTM C 1063-03 (Standard Specification for Installation of Lathing and Furring to Receive Interior and Exterior Portland Cement-Based Plaster), ASTM C 926-98 (Standard Specification for Application of Portland Cement-Based Plaster), extracted with permission. Copyright ASTM International, 100 Barr Harbor Drive, West Conshohocken, PA 19428. Building officials should obtain copies of these complete standards for reference. These may be obtained from ASTM, phone: 610-832-9585, fax: 610-832-9555, email: service@astm.org, website: www.astm.org.*

*References to the 2007 Minnesota State Building Code, are reprinted with permission of the Revisor of Statutes, State of Minnesota.*

*This booklet also makes reference, indirect or otherwise to the International Building Code and International Residential Code. Copyright 2006. 5203 Leesburg Pike, Suite 708, Falls Church, Virginia 22041: International Code Council, Inc.*

*The Minnesota Lath and Plaster Bureau would also like to thank Alabama Metal Industries Corp., Stockton Products, Niles Building Products, Fry Reglet Architectural Metals and K-Lath for the use of their pictures in this publication.*

## Introduction

As a requirement of the 2007 Minnesota State Building Code, Section 1300.0210 states “The building official, upon notification, shall make the inspections in this part...Lath and gypsum board inspections shall be made after lathing and gypsum board, interior and exterior are in place, but before any plastering is applied.” The purpose then of this manual is to provide the building official with an efficient means of retrieving information to perform an exterior lath inspection. While gypsum board and interior lathing may be important in the context of these inspections, these subjects are perhaps best suited for separate discussion. The perceived need then is to fill the void that exists in general knowledge necessary to perform a lathing inspection prior to the application of portland cement plaster (stucco).

This is not the Minnesota Lath and Plaster Bureau’s first attempt at defining issues that need to be addressed for the proper application of stucco. Please consider this information as a companion document to our handbook entitled “Stucco in Residential Construction.” With these two documents we hope that we can make the building officials job easier in improving a vital function to ensure the public a safe and watertight stucco installation. From our perspective then, a lath inspection entails more than just ensuring that the lath is correctly placed and fastened to the wall, it is also the perfect opportunity to inspect the water-resistive barriers for proper installation, flashings, placement of proper lathing accessories and the interface of other materials in the wall façade. In this context then we hope that this document is useful in directing the building official to perform a proactive function for the greater benefit of the public trust. The signatory union lathing and plastering contractors of Minnesota thank you for taking the time to read and use these materials.

# Some Lathing and Stuccoing Terminology

**Adhesive Backed Membrane:** Adhesive backed rubber sheet membranes made with tear off paper intermediate facers. Generally used in mitigating weather barrier and flashing installations.

**Admixture:** Products such as acrylic additives added in the basic stucco mix which improve the workability and performance characteristics of the end product.

**Aesthetic Rustication:** Grooves/ reveals placed in plaster to delineate lines and shadowing effects.

**Aggregate:** Sand or other granular material used in the stucco mix.

**Base Coat:** The stucco composed of the two layers called the scratch coat and brown coat.

**Bond:** Adhesion of stucco to other surfaces in which it is applied; the adhesion of the cement paste to the aggregate; the adhesion between stucco coats.

**Brown Coat:** The second coat of stucco applied over the scratch coat.

**Chopped Fibers:** Fiberglass or other strand materials approximately 1/2 inch long used in the stucco mix to provide better cohesiveness.

**Cold Joint:** The aesthetically objectionable and noticeable joining of fresh stucco applied next to set stucco.

**Cold Rolled Channel:** A heavy gauged roll formed, "C" shaped metal fabrication used as the main lateral support or cross furring for a suspended plaster ceiling. Sometimes referred to as "channel iron."

**Contact Ceiling:** A ceiling that has been constructed in direct contact with framing or floor above, without the benefit of main runners and furring.

**Control Joint:** A single component joint with an accordion shaped profile placed in a stucco membrane that opens and closes minimally as a result of the thermal expansion and contraction and normal shrinkage of stucco.

**Corner Reinforcement:** Components such as corner beads and corner aids, used to plumb, strengthen, gage and provide continuity between intersecting walls that meet at an outside corner.

**Cross Furring:** Roll formed channel attached perpendicular to the main runners for the attachment of metal lath in a suspended plaster ceiling.

**Curing:** The process by which stucco ultimately reaches its full hardness and strength.

**Darby:** A straight edged tool with handles, approximately 42 inches long made of magnesium alloy or wood. Used to float and smooth the fresh stucco brown coat.

**Dash Coat:** A wet plaster coat splatter applied to a surface as a final finish texture or to provide a mechanical key for a subsequent application of a brown coat.

**Deflection:** The limits at which an applied axial or wind load on a structural member will cause damage in a stucco membrane. The design deflection criteria for stucco should be  $L/360$ . That is the length of the span (in inches) divided by 360.

**Double-back:** The process of installing the brown coat immediately after the scratch coat has reached sufficient rigidity to accept it.

**Drip Screed:** A device used to interrupt the flow of water on a wall. A weep screed would be an example of this.

**Expansion Joint:** A two piece or multiple component accessory placed in a stucco membrane that opens and closes due to movement primarily from structural stresses.

**Finish Coat:** The final decorative layer of either cementitious stucco and color pigment or an acrylic texture applied over the base coat.

**Flashing:** Approved corrosion-resistive material provided in such a manner as to deflect and resist entry of water into the construction assembly.

**Floating:** The process of compacting and leveling the stucco basecoat.

**Fog Coat:** A fine cement based color coat used to even out and provide uniformity in integrally colored stucco finishes.

**Ground:** That part of an accessory which establishes the thickness of the stucco and also mechanically keys to the stucco.

**Hanger:** Wire, threaded rod or metal strapping used to support main runners to the construction in a suspended plaster ceiling installation.

**Hawk:** A tool with a flat metal surface supported by a single handle that is used to hold plaster before it is transferred to a trowel for application.

**Lath:** The expanded metal, welded wire or woven wire that is attached to the building's structural elements and acts as an armature for the adhesion and mechanical key of the stucco.

**Main Runner:** See Cold Rolled Channel.

**Mechanical Key:** The process of roughening a surface for the subsequent application of plaster. See also scarifying, scratch coat and dash coat.

**One Coat:** A proprietary manufactured stucco base coat product that is installed in one thin application pass.

**Reentrant Crack:** A crack that develops at the natural stress point created at the corner of an opening or penetration such as at a window or door.

**Reveals:** Aesthetic grooves or rustication placed in plaster to delineate lines and shadowing effects.

**Rod:** A long straightedge (over 5 feet) made of magnesium alloy or wood that is used to rough plumb the face of a stucco wall.

**Scarifying:** The process of raking the fresh plaster surface to provide a mechanical key for the subsequent application of another coat of plaster.

**Scratch Coat:** The first coat of fresh stucco that is scarified to create a mechanical key for the subsequent brown coat.

**Screed:** An accessory or component that aids in gauging the thickness of the stucco. Casing beads, weep screeds, control joints and corner beads would all be considered as screeding devices.

**Self-Furring:** The term used to describe the dimples that offset the lath 1/4 inch away from the substrate so that it is embedded in the stucco.

**Skim Coat:** A finish coat applied over an existing stucco finish to improve its appearance.

**Slicker:** A wood or sometimes metal straight edge tool used in lieu of a darby to float and smooth a stucco surface to plumb.

**Suction:** The absorption capacity of a material to accept another product.

**Tie Wire:** Annealed soft temper steel wire used for a variety of lathing operations.

**Trim Accessories:** Components installed during the lathing installation such as casing beads, control joints, weep screeds, etc.

**Weather-Resistive Barrier:** Correct terminology is water-resistive barrier, however, verbiage has not yet caught up in all documents. These are any of the variety of housewraps, building papers or felts that have been available to wrap the external sheathing of a building prior to the installation of the cladding. Water-resistive barrier and Weather-resistive barrier are interchangeable in this document.

# Additional Resources

- NAAM Standard ML/ SFA 920, Guide Specifications for Metal Lathing and Furring. Metal Lath/ Steel Framing Association: National Association of Architectural Metal Manufacturers.
- Portland Cement Plaster/ Stucco Manual: Portland Cement Association.
- ACI 524R (American Concrete Institute) Guide to Portland Cement Plastering.
- Portland Cement Plaster Stucco Resource Guide: Northwest Wall and Ceiling Bureau.
- Plaster and Drywall Systems Manual: J.R. Gorman, Sam Jaffe, Walter F. Pruter, James J. Rose
- AC 11 Acceptance Criteria for Cementitious Exterior Wall Coatings: International Code Council
- The Metal Lath Handbook: Gary J. Maylon
- Technical Manual No. 15, Evaluation of Three-Coat Portland-Cement Plaster (Stucco): Association of the Wall and Ceiling Industry.
- Stucco in Residential Construction: The Minnesota Lath and Plaster Bureau, [www.mnlath-plaster.com](http://www.mnlath-plaster.com).
- Useful Websites: [www.nilesbldg.com](http://www.nilesbldg.com), [www.dietrichindustries.com](http://www.dietrichindustries.com), [www.stocktonproducts.com](http://www.stocktonproducts.com), [www.amico-online.com](http://www.amico-online.com), [www.fryreglet.com](http://www.fryreglet.com)

## American Society for Testing and Materials

C 79	Standard Specification for Treated Core and Nontreated Core Gypsum Sheathing Board
C 91	Specification for Masonry Cement
C 150	Specification for Portland Cement
C 206	Specification for Finishing Hydrated Lime
C 207	Specification for Hydrated Lime for Masonry Purposes
C 208	Standard Specification for Cellulosic Fiber Insulating Board
C 260	Specification for Air Entraining-Admixtures for Concrete
C 494	Specification for Chemical Admixtures for Concrete
C 595	Specification for Blended Hydraulic Cements
C 645	Specification for Nonstructural Steel Framing Members
C 754	Specification for Installation of Steel Framing Members to Receive Screw-Attached Gypsum Panel Products
C 841	Specification for Installation of Interior Lathing and Furring
C 847	Specification for Metal Lath
C 897	Specification for Aggregate for Job-Mixed Portland Cement-Based Plasters
C 926	Specification for Application of Portland Cement-Based Plaster
C 932	Specification for Surface-Applied Bonding Agents for Exterior Plastering
C 933	Specification for Welded Wire Lath
C 954	Specification for Steel Drill Screws for the Application of Gypsum Panel Products or Metal Plaster Bases to Steel Studs from 0.033 in. to 0.112 inch Thickness
C 955	Load-Bearing (Transverse and Axial) Steel Studs, Runners (Tracks), and Bracing or Bridging for Screw Application of Gypsum Panel Products and Metal Plaster Bases
C 979	Specification for Pigments for Integrally Colored Concrete
C 1002	Specification for Steel Self-Piercing Tapping Screws for the Application of Gypsum Panel Products or Metal Plaster Base to Wood Studs or Steel Studs
C 1007	Specification for Installation of Load Bearing (Transverse and Axial) Steel Studs and Related Accessories
C 1032	Specification for Woven Wire Plaster Base
C 1063	Specification for Installation of Lathing and Furring to Receive Interior and Exterior Portland Cement-Based Plaster
C 1177	Standard Specification for Glass Mat Gypsum Substrate for Use as Sheathing
C 1278	Standard Specification for Fiber-Reinforced Gypsum Panel
C 1328	Specification for Plastic (Stucco) Cement



# Some Laths Used In Stucco Applications

**Expanded Metal Lath** (Illustration 1), sometimes referred to as diamond mesh lath, is made by cutting slits in steel sheets then pulling to effect the “diamond shaped” openings pictured.

Expanded Lath comes in various weights depending on the usage. These are 1.75 lbs./ square yard, 2.5 lb. and 3.4 lb. Typically a galvanized version of this type of lath is preferred for set tile applications as well as stucco applications over unsheathed framing. This type of construction was typical for a number of years in the Southwestern United States, but is virtually unheard of in Minnesota.

For applications of stucco over sheathing or solid surfaces, lath must be furred a minimum of 1/4”. **Self Furring Lath** meets this requirement through a process which dimples the lath (Illustration 2). Obviously, then, the lath needs to be positioned so that the dimples push inward against the solid surface.

Typically, local convention and practice for field mixed three coat stucco is to use 3.4 lb. self-furred galvanized expanded metal lath over a previously installed water-resistive barrier. Another version of standard metal lath and furred lath is one that integrates a Grade D paper backing (Illustration 3). **Paper Backed Lath** installation can become a bit tricky in properly integrating the overlaps of adjacent sheets.

**Woven Wire Lath** (Illustration 4) is another product selectively used by the stucco industry. Because it resembles poultry netting it is sometimes referred to by the street names of “Chicken Wire” or “Stucco Netting.” Over the years, it’s acceptance seems to have been relegated to installations of proprietary manufactured one-coat stucco products. It is usually ordered by its dimension across its openings along with the gauge of the wire. For example 1-inch by 20-gauge.

**Welded Wire Lath** (Illustration 5) as the name implies is constructed of strands of wire that have been fused together by welding. It is distinguished by its heavier gauge wire and 2-inch square grid pattern, typically with a paper backing. At the present time there is no local distribution for this product in Minnesota. It’s use seems to be relegated to California and other areas of the Southwest.

**Ribbed Lath** (Illustration 6) is a product that has roll formed parallel stiffeners and is often used in ceiling/ soffit applications. Typically it can be fastened directly to the structural framing however more often it may be wire tied to grillage that is suspended from the structure. Generally plaster keys in well with this type of lath, however a modification that is sometimes employed is the attachment of a Grade D paper backing to minimize wasting plaster that may flow behind the lath.

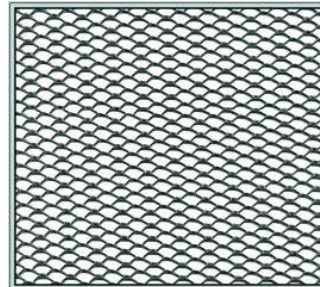

*Illustration 1. Standard Expanded Metal Lath*

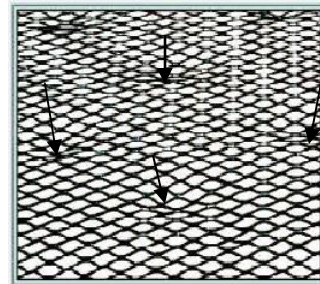

*Illustration 2. Self-Furred Galvanized Expanded Metal Lath: Notice the dimples accentuated by the arrows.*

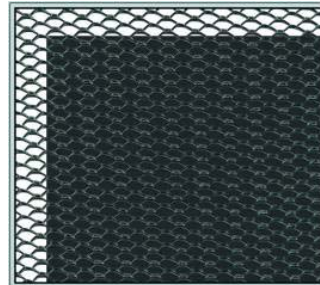

*Illustration 3. Paper Backed Lath.*

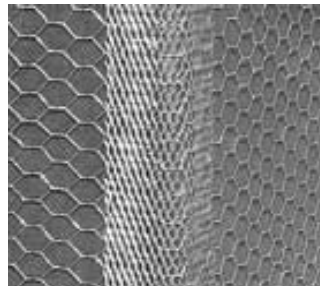

*Illustration 4. Woven Wire Lath with paper backing.*



*Illustration 5. Welded Wire Lath*

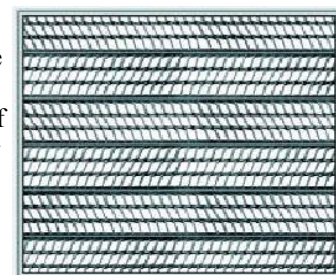

*Illustration 6. Ribbed Lath*

# Lathing Accessories

*Illustration 1: Casing Bead with expanded metal flange*

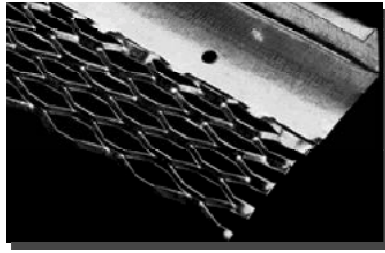

**Casing Beads** (Illustrations 1 & 2) sometimes referred to as “stop beads,” “#66 beads” or “J” channels, are used when it is necessary to terminate the stucco with a clean edge at various locations on the wall plane. These components come in different ground sizes to accommodate stucco thicknesses from ¼ inch to 1½ inch. The obvious difference between these two similar components is the fact that one has an expanded metal flange and the other is solid sheet metal with perforated holes. The expanded metal flange is often used because it is easily integrated with the lath and provides a mechanical key for the placement of the stucco. The perforated version is more often used when it is preferred to attach the bead directly to the substrate with fasteners.

*Illustration 2: Solid metal casing bead.*

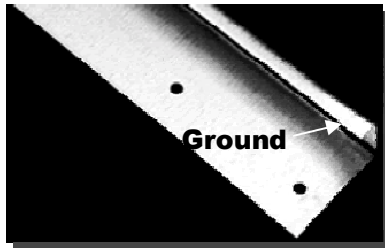

**Weep Screeds** (Illustration 3) are generally used as a basis or starting point at the proximity of the mud sill or plate at the bottom of a wall in a stucco application. As the name implies, the purpose of this component is to “weep” or pass any incidental moisture that may get behind the stucco to the outside plane of the wall assembly. Contrary to popular belief, the perforations at the bottom of the weep screed do little to help evacuate incidental moisture (the holes plug with stucco). The fact is these are more important in mechanically keying the stucco to the component. Any incidental moisture is more likely to find its way out over the cant of the inverted “V” of the component.

*Illustration 3: Weep Screed*

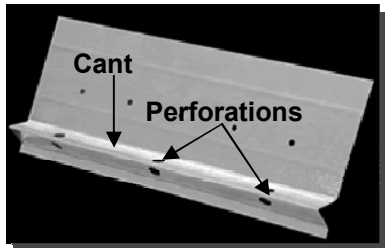

The true function of weep screeds has come under a great deal of controversy over the years. By most accounts incidental moisture will dissipate to such an extent at or near its source, that it will never be evident at the point of exit at the weep screed. From the Lath and Plaster Bureau’s standpoint, the more important function of this component is as a capillary break from the soil and also as a key marker in identifying where the backfill must stop relative to the construction.

*Illustration 4: Corner Bead*

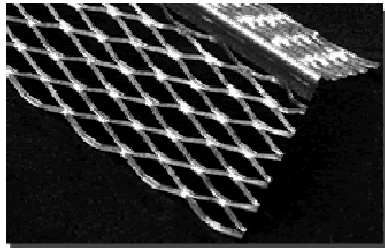

**Corner Beads** (Illustration 4) are accessories attached to outside wall corners, used to true plaster to plumb and straight as well as provide strength at these vulnerable locations. Typically corner beads come with various nosings or grounds to screed the plaster to various thicknesses. Locally they are primarily used for interior plastering applications rather than exterior, because on exterior applications they have a propensity for rusting and cracking along either side of the nosing. The preferred product by experienced plasterers for adding strength to outside corners are referred to as **Corner Aids** (Illustration 5). These products are welded wire and fully embedded in the stucco. Because of this a certain amount of finesse that comes with experience is required in truing a corner with fresh stucco.

*Illustration 5: Corner Aid*

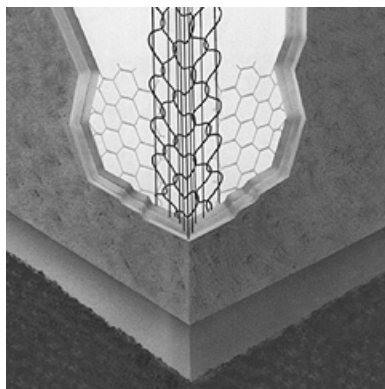

**Control Joints** (Illustration 6 page 9) are an artificial means of introducing “controlled stress” at a specific location on a wall plane, in the anticipation that cracking will less likely occur randomly within a stucco panel. Control joints are readily recog-



# Lathing Accessories (Continued)

nized as one piece components with a typical “M” or accordion type shape and expanded metal wings. Control joints provide for minimal movement capability due to the expansion and contraction of the stucco membrane such as shrinkage in its initial cure. The accordion shape reacts much like a bellows opens and closes in accepting this movement.

Several varieties of this component are offered: The “M” shaped profile, sometimes referred to as the “Double V,” is perhaps the most common control joint. In recent years this joint has been largely replaced by what is referred to as the “**J Type Joint**” (Illustration 7). This is because the “J Type” includes a lip or ground that provides for a mechanical keying of the stucco at its interfacing edge. This improvement was determined when it was realized that the “M” had a tendency to crack along its sides as the joint opens and closes with stucco movement. Another joint that provides a similar function is the **Inside Corner Joint** (Illustration 8)

### Galvanized vs. Zinc

Many accessories with expanded metal flanges are offered both in galvanized steel and solid zinc. While galvanization is simply the coating of steel with zinc, it is reasoned that solid zinc components will wear better against the effects of corrosion. While this reasoning cannot be disputed, it does come with some cautions for its use. Zinc is a much more malleable metal that can be easily cut by an errant trowel. It is also lighter and more easily bendable which makes it somewhat more difficult to install. Finally, experience has shown that it may have a tendency to grow (higher coefficient of expansion and contraction) in stucco walls with thermal changes. This can result in pinched intersections and cracking along edges that may lead to moisture intrusion issues.

### Expansion Joints

While industry publications have not defined the differences between control and expansion joints, it is widely accepted that control joints are single piece component accessories and expansion joints are multiple piece component accessories with much more movement capability. The most widely recognized expansion joint is commonly referred to as the **No. 40 Joint** (Illustration 9). As illustrated by the profile, the No. 40 expansion joint has two solid sheet metal sleeves that move independent of each other. Perforations in each sleeve are used to fasten the joint on either side of an isolation joint. In some cases this joint is expanded by the insertion of an additional piece of sheet metal between these sleeves to allow for more movement capability or to provide a larger reveal for aesthetic purposes.

Another recognized method for making an expansion joint is to use two casing beads (Illustrations 1&2) mounted in a back-to-back or knuckle-to-knuckle orientation. The space between the adjacent joints is generally determined by the anticipated movement of the joint (usually no more than 3/4 inch). The space is then filled with a bond breaker and elastomeric sealant.

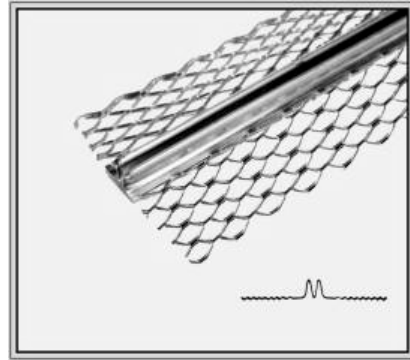

Illustration 6: “M Joint”

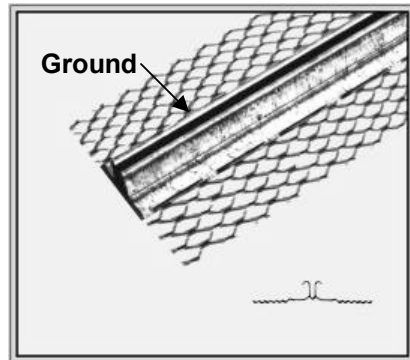

Illustration 7: “J Type Joint”

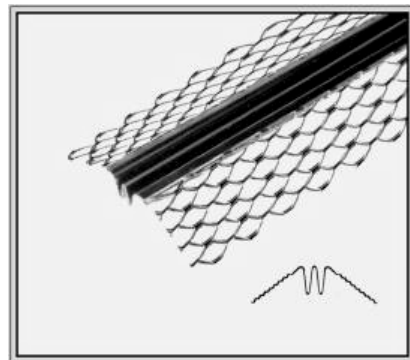

Illustration 8: Inside Corner Joint

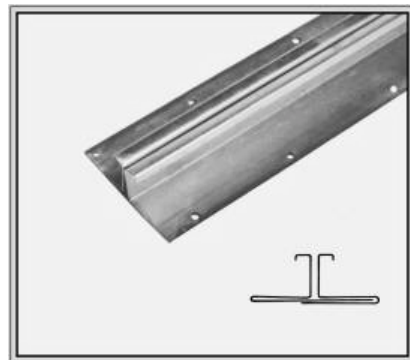

Illustration 9: No. 40 Expansion Joint

# Other Lathing Accessories

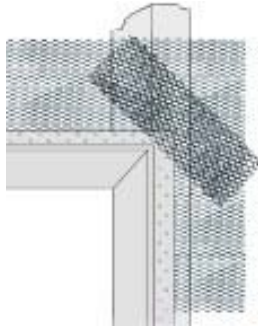

Illustration 10: Strip Lath

**Reentrant Corners** are areas on a building where there is a natural stress point for stucco to crack. The most common example of reentrant corners are the corners created by a window opening. Although it is not mandatory, **Strip Lath** (Illustration 10) is often employed as reinforcement for these areas. Strip lath is no different than any other expanded metal lath, except that they are cut into strips approximately 4-6 inches wide.

Similar in use as corner aids or corner bead on outside corners, **Corner Lath** (Illustration 11) is sometimes used on inside corners in lieu of bending lath around the corner to aid in providing continuity and strength.

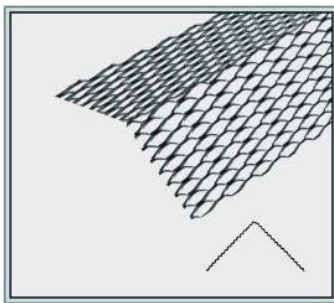

Illustration 11: Corner Lath

**Reveals** are sometimes used in plastering applications to provide **aesthetic rustication** or grooves. Fry Reglet offers a variety of configurations that are referred to as **Channel Screeds** (Illustration 12) for banding effects, F- Reveals for top of wall rustication and other profiles. According to Fry Reglet, channel screeds also provide the “functional value of control joint performance to help control cracking caused by thermal changes and minor building movement.”

Fry Reglet, Plastic Components and Vinyl Corp. also offer component profiles for **Soffit Vents** (Illustration 13). Some come with built in **drip screeds** that decouple the fascia from the soffit. This is helpful in preventing water draining down the fascia from backwashing onto the soffit because of surface tension.

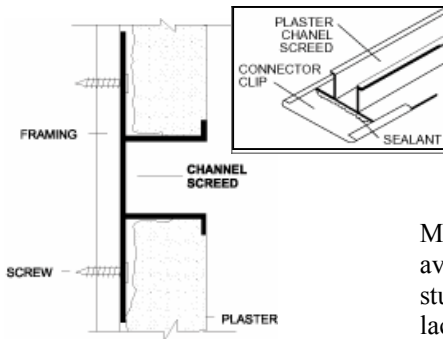

Illustration 12: Channel Screenshot

## Metals and Plastics

Galvanized and zinc components predominate the stucco industry in Minnesota, however anodized finished aluminum is often used for flashing elements as well as Fry Reglet reveals described earlier. Unless it is protected by some type of coating or gasketing, aluminum is subject to galvanic corrosion in stucco applications.

Many of the same components available in galvanized or zinc are also available in a plastic version. It is however rare to see these materials in a stucco application in Northern climates. The predominant reason for their lack of use is the question of whether they can accept the extreme thermal changes. Depending on their quality, they may be susceptible to cracking, bending or splitting..

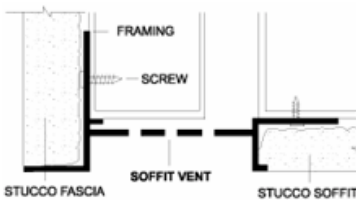

Illustration 13: Soffit Vent

## Tie Wire

The predominate product used for the attachment of metal accessories to lath or lath to cross furring in a suspended ceiling applications is wire. Gauge of wire correlates with the United States Steel Wire Gauge numbering system. Wire should be galvanized and annealed low-carbon steel. Lathers use a variety of tying configurations for specific uses. Terminology often expressed includes the **saddle tie, butterfly tie, figure eight tie, stub tie and double wrap tie**. While experienced lathers are often called upon to help design framing systems for special lathing applications, this experience should not be substituted for the knowledge of a qualified and licensed engineer.

# Substrates and Weather-Resistive Barriers

**Gypsum Sheathing** refers to those products with a weather resistant paper surface and a gypsum core.

**Glass Mat Faced Gypsum Sheathings** are paperless sheathings that have a proprietary glass mat facing with a specially treated gypsum core (G-P Dens-Glass Gold). A relatively new product is a **gypsum-cellulose** panel product that has no paper or glass mat facer (USG Fiberock Aqua-Tough). These products require a weather-resistive barrier consisting of one layer of No. 15 Asphalt Felt complying with ASTM D 226 for Type 1 Felt. Utility felts and ASTM D 4869 felt sold through home improvement stores generally do not meet this criteria. Check packaging, banding or with distributor to determine if product meets this requirement.

**Wood based sheathing** refers to any product that has wood, wood byproduct or cellulose as its principal material. At present these would include Exposure 1 Plywood and Oriented Strand Board, Exterior Grade Plywood and Ligno-Cellulosic Fiberboard (Bildrite). According to the IBC and 2003 Minnesota State Building Code, these products require a weather-resistive barrier at least equivalent to two-layers of Grade D Building Paper.

**Concrete and Concrete Masonry Units** do not require a weather-resistive barrier. However, for aesthetic reasons on residential installations the stucco is sometimes installed to be continuous from a framed wall to an exposed walk-out type of foundation. In this event it is good practice to continue the weather-resistive barrier onto the foundation wall to maintain a continuous drainage plane in back of the stucco. Subsequently this would also entail fastening the weep screed to the foundation wall and also fastening lath over the weather-resistive barrier and into the foundation wall.

## Alternatives to ASTM D 226 Felt

Alternatives to ASTM D 226 Felt that meet the criteria of IBC 1404.2 and IRC 703.2 include: Fortifiber Jumbo Tex, Heavy Duty Jumbo Tex and Super Jumbo Tex Grade D Building Papers; Tyvek Homewrap, Stuccowrap and Commercialwrap; Typar Housewrap (2003 IBC and IRC); and Weathermate Plus Housewrap from Dow Chemical.

## Alternatives to Grade D Building Paper

Alternatives to Grade D Building Paper that meet the criteria in IBC 2510.6 and Minnesota Rules Section R 703.6.3 include: Dupont Tyvek; Homewrap, Commercial Wrap and StuccoWrap, Dow Chemical; Weathermate Plus and BBA NonWovens Typar Housewrap.

## Applicable Code References:

- IBC 1403.2 Weather protection
- Minnesota Rules 1305.1404 Section 1404.2 Water-resistive barrier
- IBC 2510.6 Weather-resistive barriers
- IRC R703.2 Weather-resistive sheathing paper
- Minnesota Rules 1309.0703 Section R703.6.3 Weather-resistant barriers

**Note:** The 2007 Minnesota State Building Code includes the following amended rule change in the IRC section:

**R703.6.3 Water-resistive barriers.** Water-resistive barriers shall be installed as required in Section R703.2 and, where applied over wood-based sheathing, shall include two layers of a water-resistive vapor-permeable barrier. Each layer shall meet both of the following requirements:

1. A water resistance not less than that of 60-minute Grade D paper; or a minimum hydrostatic head of 60.9 cm when tested in accordance with hydrostatic pressure test method AATCC 127-1998; or a minimum water transudation time of 60 minutes when tested in accordance with ASTM D-779.
2. A water vapor permeance not less than that of no. 15 felt; or a minimum permeance rating of 8.5 gr/h.ft.<sup>2</sup> in Hg (US perm) ( $4.9 \times 10^{10}$  kg/Pa.s.m<sup>2</sup>) when tested in accordance with Procedure B of ASTM E96.

**Exception:** One layer of water-resistive barrier complying with R703.2 is permitted when a drainage space that allows bulk water to flow freely behind the cladding is provided.

## ASTM Standards

- ASTM C79 Standard Specification for Treated Core and Nontreated Core Gypsum Sheathing Board
- ASTM C1177 Standard Specification for Glass Mat Gypsum Substrate for Use as Sheathing
- ASTM C1278 Standard Specification for Fiber-Reinforced Gypsum Panel
- ASTM C208 Standard Specification for Cellulosic Fiber Insulating Board

## Available Evaluation Service Reports

**ER-1025** Fortifiber Sheathing and Building Papers  
**NER-642** Dupont Tyvek  
**ER-4000** Dupont Tyvek  
**NER-640** Dow Chemical, Weathermate Plus  
**ESR-1404** BBA NonWovens, Typar  
**ER-5578** USG Fiberock  
**NER-574** Georgia-Pacific Dens-Glass Gold  
**ER-3567** American Hardboard Association (lapsed)

# Installing Water (Weather)-Resistive Barriers



Illustration 1: Installing WRB at Corners

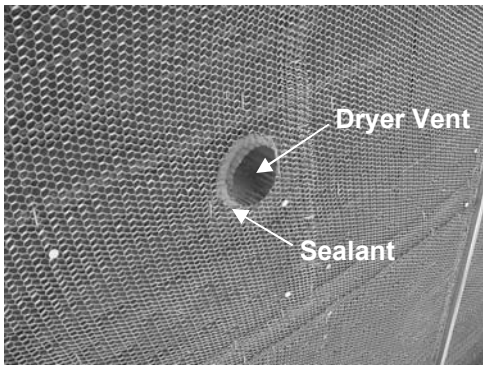

Illustration 2: Pipe and Vent Sleeves



Illustration 3: Electric Meter and Fan Vent



Illustration 4: Weep Screed

## Water-Resistive Barrier Installation General

- Applicable references: IRC R703.2
- Water-resistive barriers should be installed horizontally with the upper layer lapped over the lower layer a minimum of 2 inches.
- Where vertical joints occur there should be a minimum 6 inch overlap.
- The Minnesota Lath and Plaster Bureau recommends that the water-resistive barrier be wrapped continuously through both internal and external corners (Illustration 1)
- For wood based sheathing it is necessary to have two layers of water-resistive barrier. This is commonly accomplished with a double laminate layer roll of building paper or as illustrated in this photo, two subsequent installations of water-resistive barriers.
- Please also refer to our handbook entitled “Stucco in Residential Construction” for more information on this subject.

## Pipe and Vent Sleeves

- Ensure that the weather-resistive barrier is snug around all breaches created by ducts, pipes, etc.
- Weatherproof with sealant or adhesive membrane tape as appropriate (Illustration 2).
- This issue is also addressed in the Bureau Handbook entitled “Stucco in Residential Construction.” See page 23.

## Isolating Devices Installed Prior to Stucco

- If vent covers, electric meters and other devices are installed prior to the stucco, it may be necessary to isolate them from the stucco to preclude moisture intrusion issues.
- Illustration 3 demonstrates how a cap flashing and casing bead may be installed as such a measure.
- Please also see our handbook entitled “Stucco in Residential Construction” for more information.

## Weep Screed (Illustration 4)

- Applicable references: MN State Bldg. Code R703.6.4, IBC 2512.1.2
- 3 1/2 inch attachment flange should be attached at or below foundation plate line on exterior stud walls.
- Shall be placed a minimum 4 inches above the earth and 2 inches above paved areas.
- Weather-resistant barrier should lap the attachment flange.
- Lath shall cover and terminate on the attachment flange of the weep screed.
- Weep function is provided by the cant of the weep screed’s inverted “V.” See accessories.
- Perforations on inverted “V” of weep function as a mechanical key for the stucco. See “Accessories.”





# Prosit! Salud! Cups up! Cheers!

## ... Expounding on Expanded Metal Lath



*Note: This article is reprised from the Minnesota Lath and Plaster Bureau HOT SPOT, Fall 2004*

As you may guess, the Minnesota Lath and Plaster Bureau gets all kinds of inquiries, ranging from the exceptionally technical to the uniquely weird. While the topic of this article does not extend to either side of this spectrum, it is one that perhaps needs some clearing up. And no, we are not talking about common drinking salutations, but the term “Cup’s up” seems apropos to that event.

What “cups up” refers to is the orientation of expanded metal lath fastened to a vertical wall plane. Why, may you ask, is this interesting? One reason is that it is critical to the proper installation of a plaster wall system. A second reason is that it is not addressed by the current lath standard, and moreover it is not addressed by any known authority on plastering. We have chosen to write about this subject because we have gotten calls about it. And in fact we now reference it in our new checklist for residential stucco installation.

To understand what “cups up” means, we must first take a look at how expanded metal lath is made: It starts out as a sheet of steel with a series of parallel slits cut into it (*see top illustration*). When cut in this manner and then pulled in opposing directions it yields the “hexagonal” pattern matrix that we have become accustomed to.

By virtue of this process the resulting pattern has what might be described as a grain pattern. Depending on the orientation of the lath on a wall, you will feel a roughness or friction as you run your hand in one direction and smooth evenness in the opposing direction. As a comparison you might consider the scales or fins on a fish, which are smooth when you run your hand from the head to the tail, but spiny and rough when you move from the tail back to the head.

The pattern of “cups up” is rarely noticed by the casual

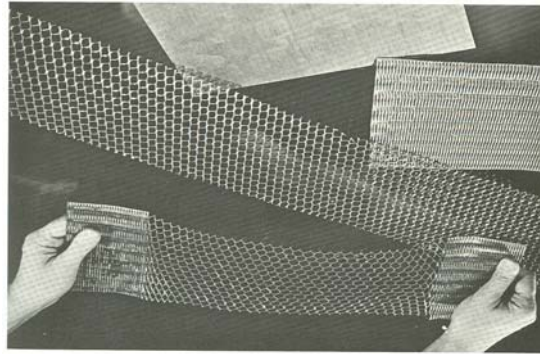

*Expanding metal lath. Photo from Manual of Lathing and Plastering, John Diehl, 1960*

observer, so the tactile test of rubbing your hand over the lath is perhaps as good indicator of its orientation as any. Considering the terminology, you might expect that this feeling of roughness would be experienced as you rub your hand down the face of the lath, but quite to the contrary you will find that it is rough as you run your hand up on the face of the lath.

The trained eye can also detect the difference in orientation visually. “I can spot an upside down lath job a mile away,” explains Ham Lake Building Inspector and former lather, Carl Stephenson. “The indicator that the cups are down is the reflectiveness of the lath. The shininess can be seen from down the street.”

The other problem you run into in describing “cups up” is that many will interpret this description as referring to the self furring dimples. With that, some well intending do-it-yourselfer may install lath not only upside down (cups down) but inside out (dimples projecting outward) as well (see illustration below).

To provide a little more clarity on this subject we have taken a couple of snapshots of metal lath and added some graphics to illustrate the point. On the

*Self Furring Dimples (arrows): Photo taken from the Metal Lath/ Steel Framing Assoc.*

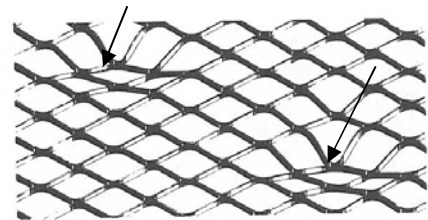

following page is a view of metal lath in the “cups down” orientation. When you look closely at the lath, the cups (indicated by arrows) can be seen at the bottom of each little hexagon and are pitched downward. Also notice the slight shininess of each of these little cups. This is probably better described to think of



these “cups” as more like little slides on a sunny afternoon. This may be a cute representation, but it is what we are trying to avoid.

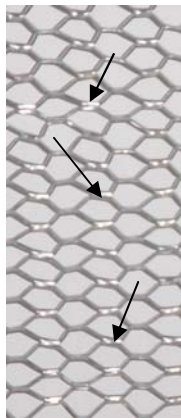

*“Cups Down” orientation that should be avoided*

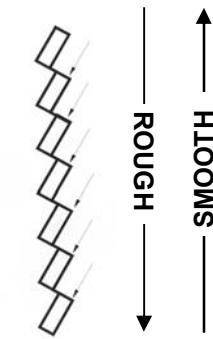

Profile illustration

**Implications**

To the experienced plasterer the ramifications of orienting the lath “cups down” is akin to piling snow on that playground slide. The snow just ends up on the ground at the bottom of the slide. Similarly, when a plasterer draws a swath of mud (plaster) over the lath in a bottom to top motion, a lot of the material could end up on the ground. Orienting the lath in a “cups up” position however and the lath grabs and holds the mud as the plasterer pushes and completes the action of placing the material. The mud is then set by the retracting opposite motion from top to bottom

What does this mean to the future of the plaster application? Much like an artist working with clay on a wire armature, lath is the armature for the fresh plaster in its plastic state. Orienting the lath in a “cups down” orientation defeats the plasterer in trying to place and push the plaster through the weave of the lath. This can lead to inconsistent thickness, weak plaster and even air pockets in the application. This results in an application with limited restraint capacity to stresses imposed upon it, which shows itself as cracks and spalls and is less impact resistant.

Contrast that snapshot above with the one below which shows the lath in the correct, “cups up” orientation. Note the lack of reflectiveness in this snapshot and the orientation of the hexagons in the “cups up” position. This creates little hollows that cleat into the stucco when it is installed in a swath from the bottom up.

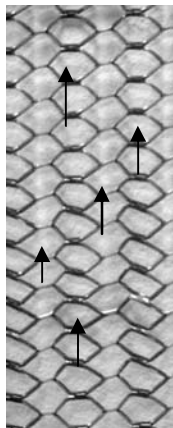

*Correctly oriented lath in the “Cups Up” position, creates little hollows that cleat into the stucco.*

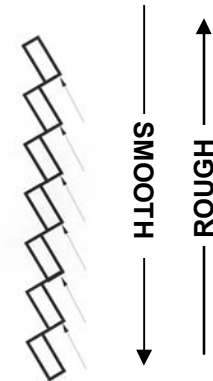

Profile illustration

While examples of stucco failures as a result of this issue may exist, they are perhaps more urban myth than fact. We have not seen instances where a bounced basketball against a stucco wall has led to the fracture of large sheets of stucco. However, we do not want to see it happen either. 3/4” stucco weighs approximately 9 pounds per square foot. The potential for calamity is there. So take the meaning of “cups up” seriously. Better yet, hire a lather who knows what he is doing. If you are uncertain, give us a call, we know plenty of good contractors with highly qualified and trained lathers. After all you don’t really want “mud in your eye,” do you? - Steve Pedracine

**Lath Attachment**

**General**

- Installation of lath should conform to ASTM C 1063.
- Lath should lap 1/2 inch at sides and 1 inch at ends.
- Stagger end laps of lath from course to course.
- Lath ends that do not land on a stud should be wire tied.
- Fasteners used in field between framing supports should not penetrate through sheathing.

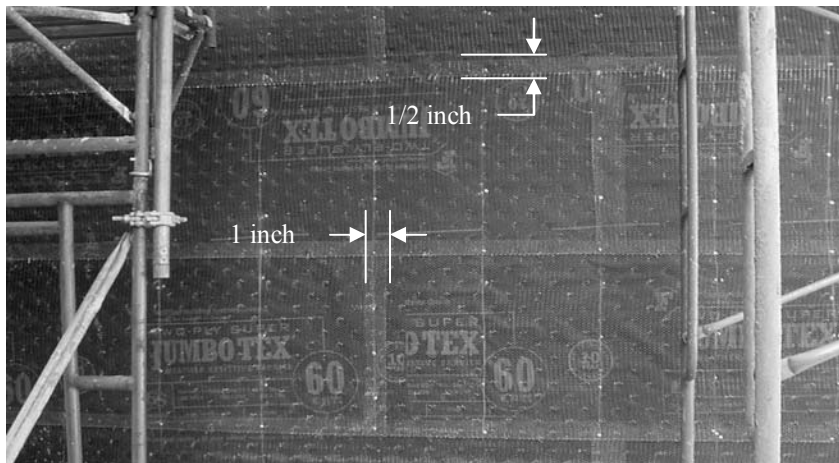

# Lath Attachment (Continued)

## Lath Attachment Wood Framing

- Applicable references: R703.6.1, ASTM C 1063, Section 7.10.2.2. ASTM C 1002
- Staples: 16 gage (0.062 in), 3/4 inch wide crown.
- Screws: No. 6, 0.136 inch shank. Type A, Pan or wafer head.
- Nails: 11 gage (min) roofing nail, with a 7/16 inch head . Or 6d common nails, driven in and clenched.
- Minimum 3/4 inch fastener penetration into framing (stud) support.
- Minimum engagement of three strands of lath.
- Spacing along vertical supports = 6 inches in accordance with R703.6.1, 7 inches for ASTM C 1063.

## Screw Lath Attachment Metal Framing

- Applicable reference: ASTM C 1063 Section 6.7.2, 7.10.3.3 . ASTM C 954, C 1002
- No. 6, 0.120 inch shank.
- 7/16 inch minimum diameter head. Pan or wafer head type.
- Self drilling and self tapping.
- Minimum 3/8 inch penetration into stud.
- Head should contact a minimum of three strands of lath.
- Spacing along vertical supports = 7 inches in accordance with ASTM C 1063.

## Lath Attachment Concrete and Concrete Block

- Applicable references: ASTM C 1063, Sections 7.10.4 and 7.10.5.
- Low velocity power or powder actuated fasteners. ITW Ramset Trakfast zinc coated, Hilti X-ZF (powder), X-GN (gas) or equivalent.
- Concrete stub nails: 3/4 inch long with 3/8 inch diameter heads.
- Minimum: Attach with six power or powder actuated fasteners located at each corner of lath and at mid point along long edge of each side. Then stub nail balance at 16 inches o.c. horizontally and 7 inches vertically.
- Better: Use power or powder actuated fasteners entirely.

**Note:** The 2007 Minnesota State Building Code includes the following amended rule change in the IRC section:

**R703.6.1 Lath.** All lath and lath attachments shall be of corrosion-resistant materials. Expanded metal or woven wire lath shall be attached with 11 gage nails having a 7/16-inch (11.1 mm) head, 16 gage staples, spaced at no more than 6 inches (152 mm) at supports. Nails or staples shall penetrate wood framing support members not less than 3/4-inch (19 mm).

## Lath Attachment Concrete and Concrete Block with Stub Nails

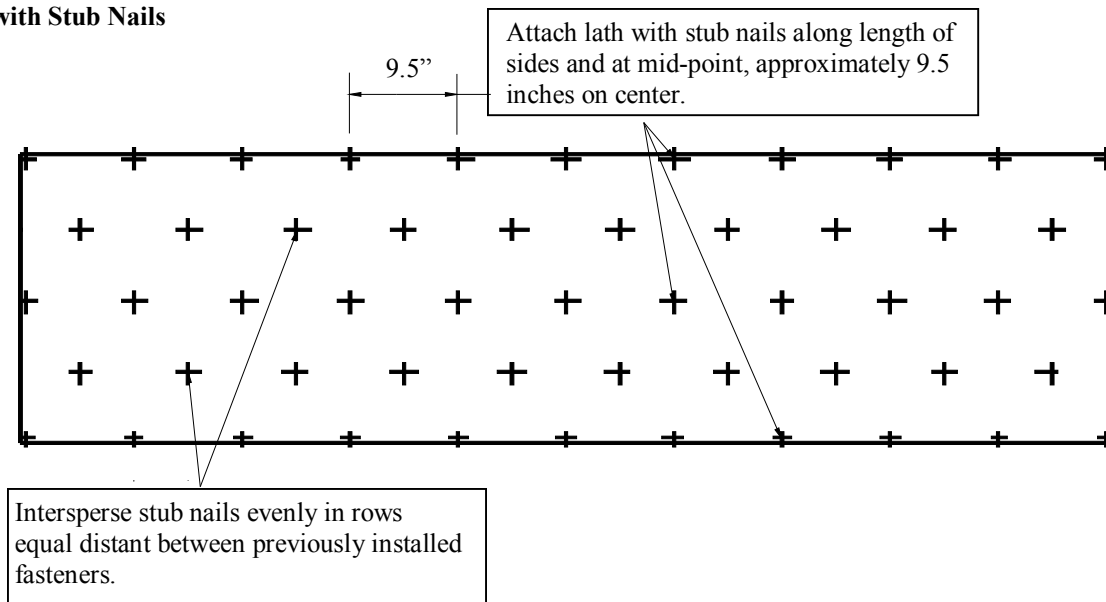

# Control and Expansion Joints

## **The Difference Between a Control and Expansion Joint**

Those experienced in the plastering industry have long realized that there is a distinct difference in the performance capabilities of control and expansion joints. Until only recently however has the ASTM Committee responsible for Standard Specification C 1063 made an attempt at defining these two very different components.

From the Minnesota Lath and Plaster Bureau's standpoint the distinction is generally derived from the performance function of each component. Because a control joint is a one-piece accessory it provides very minimal movement capability in absorbing thermal expansion and contraction as well as normal shrinkage of stucco as a result of curing. An expansion joint, on the other hand, has two or more pieces that are attached at opposing sides of a building joint to absorb structural stresses.

## **Residential Construction**

You are more likely to see control and expansion joints on commercial projects than residential ones. The easy reason that they have never really caught on in residential is the fact that wall areas tend to be smaller. Local conventions and practices would also suggest that homeowners would object to the way they look aesthetically and that they are prone to water intrusion issues.

With that said, the dilemma code officials face is enforcement, because the code does not recognize a difference in construction methods from residential and commercial and neither does ASTM C 1063 and C 926 which are referenced by the code. This is a matter of great controversy both within the industry and amongst code officials, however what seems agreeable to most parties is the fact that the use of these accessories should be defined by the contract documents rather than by the plasterer. Specific reference to this issue can be found in ASTM C 926 section A2.3.1.2.

In an attempt to clarify this issue in the code the Minnesota Lath and Plaster Bureau, in consultation with the Building Codes and Standards Division, submitted the following rule change which was adopted in the residential (IRC) section of the 2007 Minnesota State Building Code:

***R703.6.1.2 Control and Expansion Joints.*** Provisions for the control of expansion shall be determined by the exterior plaster application designer. ASTM C 1063 sections 7.11.4-7.11.4.4 do not apply.

## **Stopping Lath at Control Joints**

Another controversial subject that still is a matter of much industry discussion is the subject of cutting or stopping lath so that it is discontinuous at control joints. One position that has been taken on this matter is to suggest that the bellows (the "M" profile) of the joint must remain independent of the lath so that it can open and close freely with expansion and contraction of the stucco. The only way this can be done is to cut the lath with a power shears then position and wire tie the control joint over the cut lath. The other position taken is that this action is a moot point because the lath is attached to the structure of the building which negates any independent open and closing action of the bellows. Moreover, stucco in its plastic state, squeezes in and behind the joint, and in effect fuses the cut lath back together as it hardens and cures.

The Minnesota Lath and Plaster Bureau along with its counterparts the Northwest Wall & Ceiling Bureau, The Texas Lathing and Plastering Contractors Association, the Lathing and Plastering Institute of Northern California et. al., all prescribe to the latter philosophy described above rather than the former, which is contradictory to ASTM C 1063 section 7.10.1.4.

Until these controversies can be reasonably settled, it is the suggestion of the Minnesota Lath and Plaster Bureau that all accessories be attached to the substrate as required by ASTM C 1063 section 7.11.1.1. In the event that the accessory must be attached in a position between supports, it should then be wire tied to the lath. Moreover, with respect to whether the flange of the accessory is behind the lath or on top of the lath is inconsequential to the overall effectiveness of the installation, provided that the flanges of the component are embedded in the stucco.



## Control and Expansion Joints

### Control Joint Wall Areas

- Applicable reference: ASTM C 1063, sections 7.11.4.1, 7.11.4.2
- Wall areas are generally broken up into panels of no more than 144 square feet.
- Distance between joints should not exceed 18 feet in either direction.
- Panel length to width ratio 2.5: 1.
- Note: For ceilings or soffits, areas are generally broken up into panels of no more than 100 square feet.

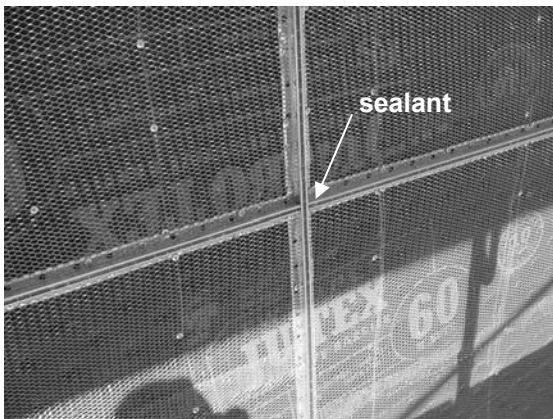

### Control Joint Intersection

- Applicable reference ASTM C 1063 sections 7.10.1.4, 7.11.4 - 7.11.4.4
- Water-resistive barrier remains continuous in back of joint intersection.
- Vertical control joints have precedence over horizontal control joints. Verticals should run continuous and horizontals abut.
- Flanges should be mitered for neat fit.
- Abutting horizontal control joints should be spaced 1/8 – 1/4 inch from verticals for expansion relief.
- Seal all intersections.
- Protective tape should be left in place until after stucco installation.



### Control Joint Intersection at Floor Line Expansion Joint

- Upper portion of water-resistive barrier installed over flange of lower flashing for positive drainage over exterior finish. Lower portion of water-resistive barrier installed above and behind upper water-resistive barrier.
- Horizontally oriented expansion joint remains uninterrupted by vertical control joint.
- Abutting vertical control joint spaced 1/8 – 1/4 inch from horizontal for expansion relief.
- Note use of sealant of control joint ends.
- See also “Weeping Expansion Joint at Floor Line” on page 20.



# Control and Expansion Joints

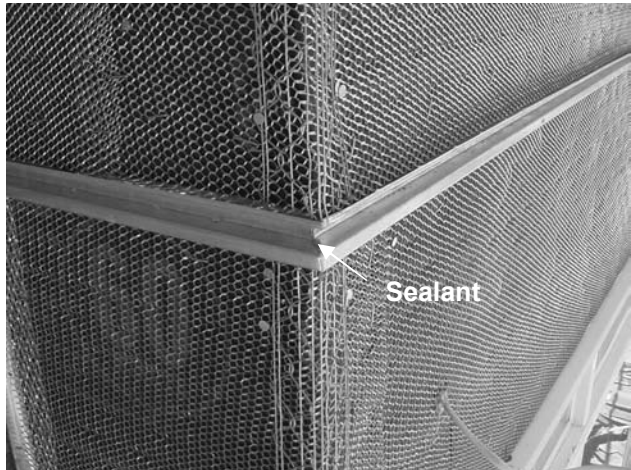

## Abutting Joints at Corners

- Mitered joinery should be sealed with elastomeric sealant to protect from moisture entry.
- Same procedure applies to inside corners as outside corners

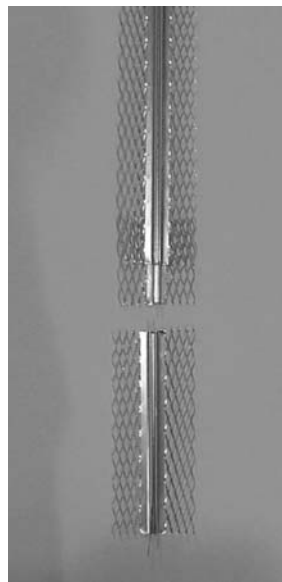
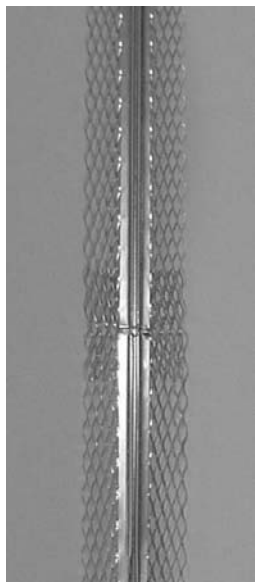

## Abutting Control Joints

- Control joints and other accessories come in standard lengths of 10 feet. Typically then, any run longer than ten feet requires that the accessories be butted together.
- To ensure positive drainage, experienced lathers will often overlap the components (far left illustration). This is done by clenching the bottom control joint so that it nests under the upper control joint.
- Another option (near left) is to clench a small piece of control joint that is used to splice the components together.
- All butted ends are vulnerable to moisture intrusion, so it is preferable that these ends be sealed with elastomeric sealant.



## Control Joint Abutting Weep Screed

- Joint should be cut at an angle to accommodate cant of weep screed.
- Bead held back slightly (approx. 1/8-1/4 inch) to accommodate eventual expansion into weep.
- End joinery is sealed with elastomeric sealant.



# Control and Expansion Joints

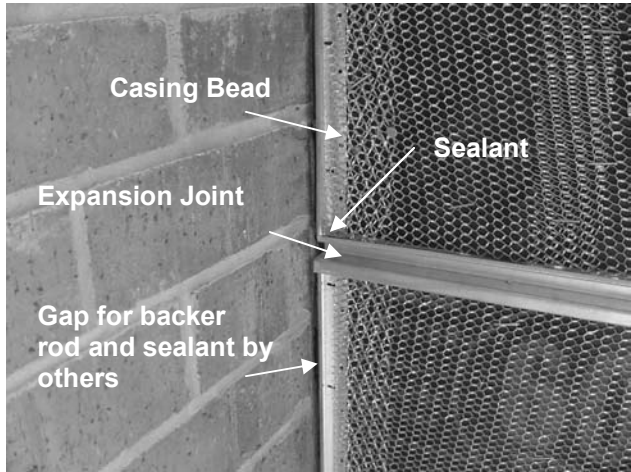

## Termination of Stucco at Dissimilar Material

- Applicable reference: ASTM C 1063 section 7.11.3.
- Gap is allowed between casing bead and brick interface for insertion of backer rod and elastomeric sealant by others.
- Expansion joint takes precedence over casing bead. Note how casing bead is interrupted by expansion joint.
- Interface of accessories are sealed with elastomeric sealant.

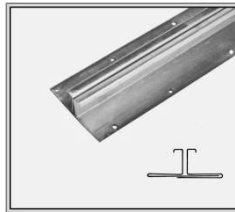
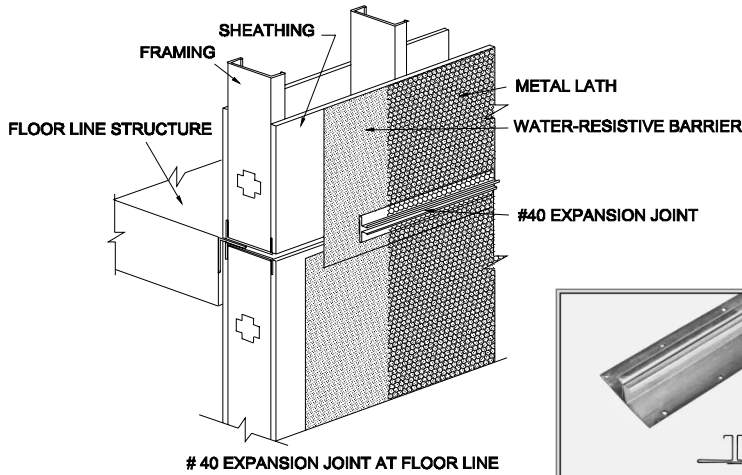

## #40 Expansion Joint at Floor Line

- Water-resistant barrier remains continuous behind expansion joint.
- Piece of adhesive backed membrane is sometimes used in back of joint for added moisture protection.
- Expansion joint positioned at floor line, with upper (female) half attached through perforations along framing bottom track. Bottom half attached through perforations along framing top track.
- Metal lath laps flanges of joint.
- Closed cell backer rod and elastomeric sealant can be installed for best resistance to moisture issues.

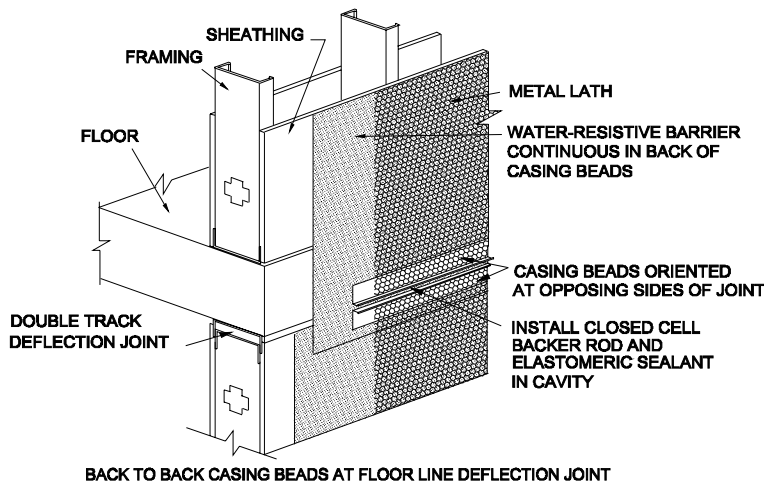

## Casing Bead Expansion Joint at Floor Line Deflection Joint

- Water-resistant barrier remains continuous behind expansion joint.
- Piece of adhesive backed membrane is sometimes used in back of joint for added moisture protection.
- Joint positioned at head of wall with top casing bead attached along floor or stationary track.
- Bottom casing bead attached along moving portion of double track.
- Metal lath laps flanges of casing beads.
- Install backer and sealant.

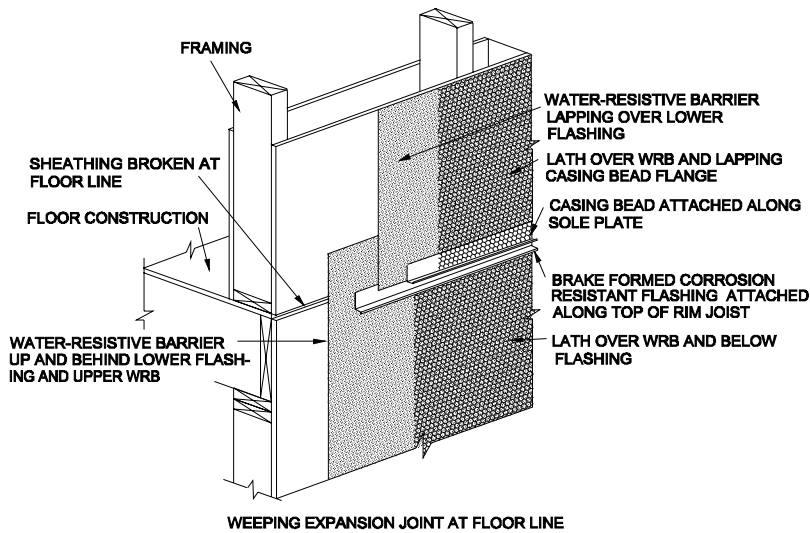

### Weeping Expansion Joint at Floor Line

- Slight cant on bottom break formed flashing provides positive drainage.
- Break formed flashing can include ground with cleat for mechanical key to stucco.
- Note position of lapping WRB's for redundancy behind joint.
- Top layer of WRB laps lower flashing for weep.
- Note: construction is not necessarily indicative of the appropriateness of joint. Back to back casing beads or #40 joint may also be used if weep function is not a criteria.

## Lath and Accessories at Windows



### Casing Bead Around Window Perimeter

- Applicable reference ASTM C 1063 section 7.11.3.
- Penetrating elements should be isolated from the stucco.
- Stucco is terminated with a casing bead around perimeter to provide a cavity for the insertion of backer rod and elastomeric sealant.
- Casing bead at corners should be continuous rather than cut to help prevent water intrusion.

Note: The Minnesota Lath and Plaster Bureau addresses the issue of preparing rough window openings in our handbook entitled "Stucco in Residential Construction." Please refer to pages 14-20 of that publication for more information. [www.mnlath-plaster.com](http://www.mnlath-plaster.com).

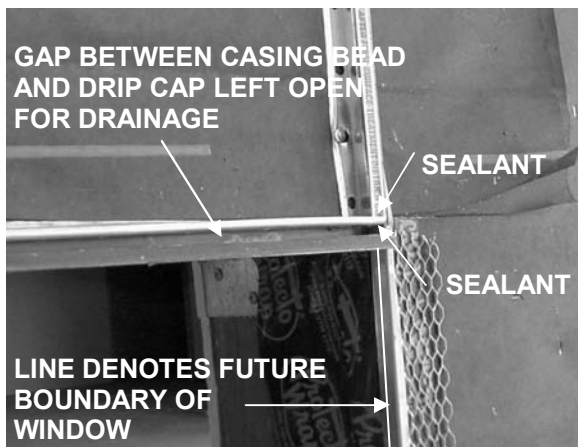

### Control Joint Meeting Window Head Corner

- Provide gap between control joint and casing bead of approximately 1/8-1/4 inch to allow for lengthwise expansion of control joint.
- Meeting intersection should be sealed with elastomeric sealant and tooled for positive drainage.
- Note extension of drip cap flashing that captures the bottom end of the intersection. This limits moisture from getting behind backer rod and sealant at jamb.
- Sealant should also be applied to close any gap between the drip cap and casing bead at jamb.
- Another option that some contractors employ, is to eliminate the casing bead at the head of the window and simply terminate the control joint at the drip cap.
- For ganged window units, it is better practice to use one continuous drip cap flashing than to install multiple separate pieces between units.

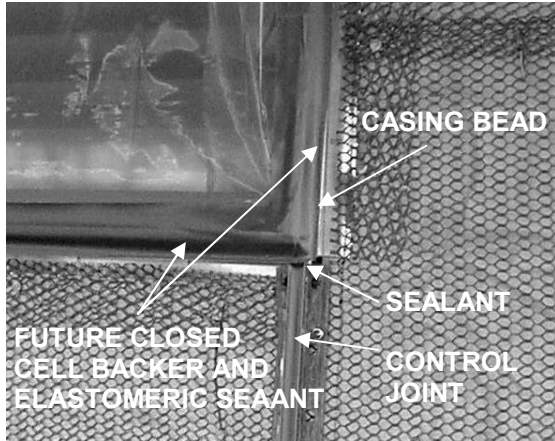

### Control Joint at Window Sill Corner

- Similar to head condition, control joint should terminate into casing bead installed around perimeter of window.
- A slight gap should be allowed (1/8-1/4 inch) for lengthwise expansion of the control joint.
- Meeting intersection should be sealed with elastomeric sealant.
- Closed cell backer rod and elastomeric sealant installed later at jambs and sill.

## Some Typical Installation Details

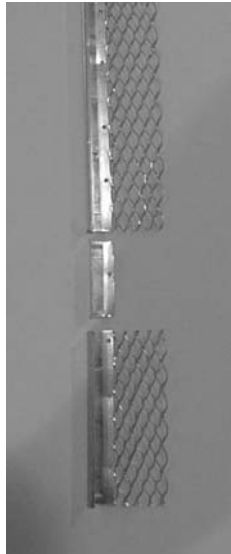
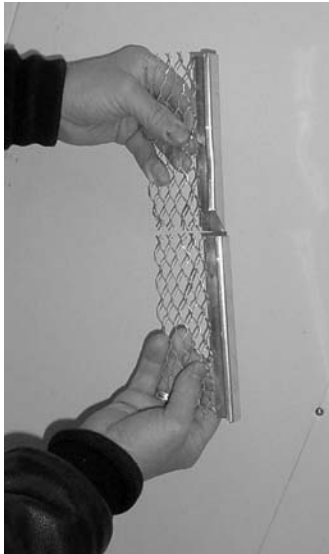

### Abutting Casing Beads

- For continuity of some abutting accessory joints, skilled lathers will often overlap or splice components together.
- What is illustrated at left is the overlap of two casing beads.
- Note how the back flange of the top casing bead has been cut out so that the ground nests into the lower casing bead.
- This method is preferable to simply butting the casing bead, especially at a moisture vulnerable area such as a termination at a window.
- Another method at right illustrates the fabrication of a separate splicer that is nested into both abutting pieces.

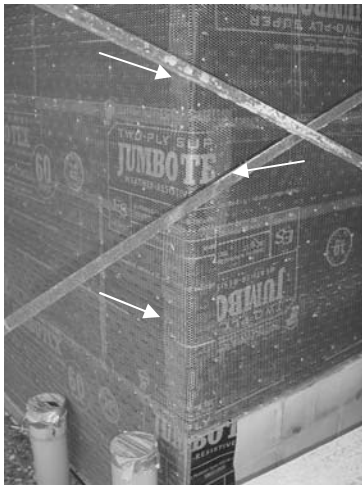

### Outside Corner Aid

- Applicable reference ASTM C 1063, section 7.11.2.1
- Lath is wrapped around corner from one side to the other and extended to the next support. (Left)
- Pattern is repeated from opposing side.
- Corner aid is then installed over lath. (Right).

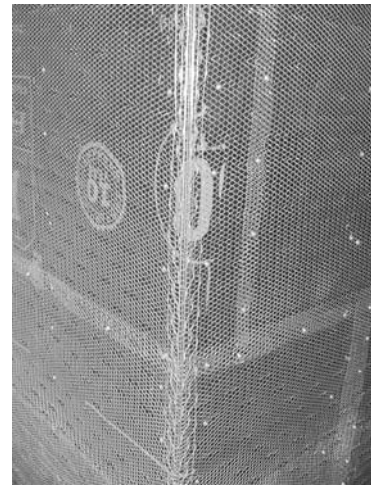



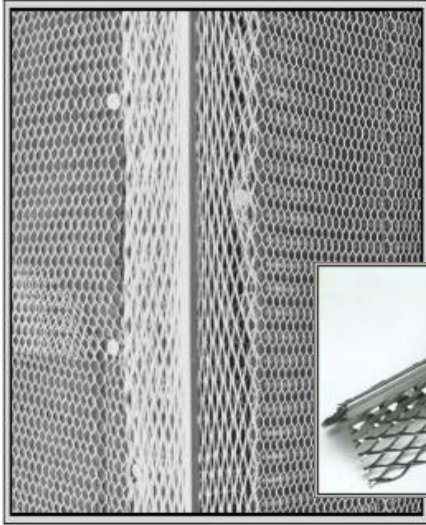

### Outside Corner Bead

- Nosing on at outside corner acts as a screed for proper thickness of stucco.
- Sharp arrises, however, prone to rusting and separation cracking along nosing edge.

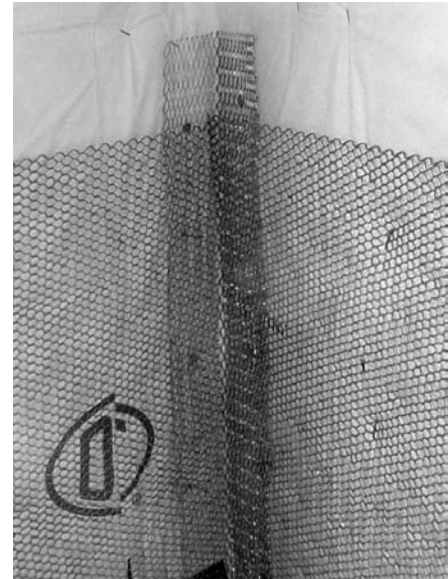

### Inside Corner Lath

- Discontinuous lath installed at an inside corner will result in cracking at this location.
- Lath is often bent at a 90° angle and continued to the next support.
- In lieu of bending lath through an inside corner, corner lath is sometimes used to provide continuity.

## Roof Line

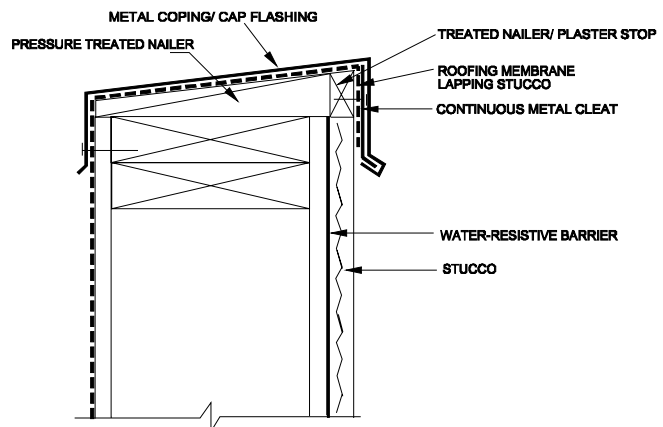

### Parapet at Membrane Roof

- For redundancy, membrane from roof should continue over parapet wall and stucco termination.
- Coping/ Cap flashing should have interlocking watertight seams.
- Continuous cleat to hold coping/ cap flashing in place over stucco.
- Consider sealing interface of coping/ stucco with elastomeric sealant to prevent wind driven rain.

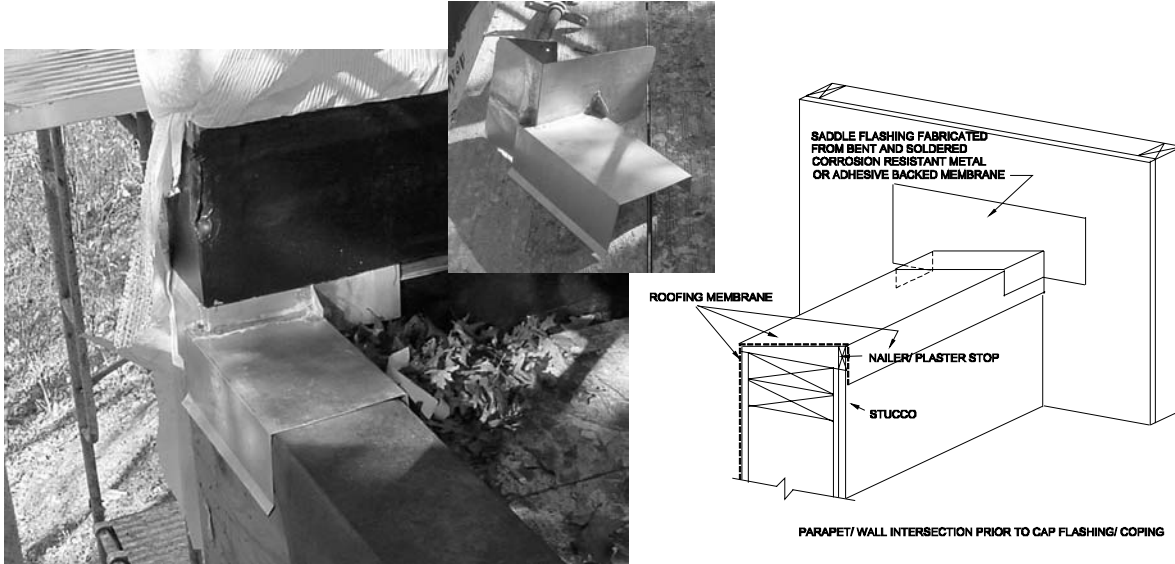

**Parapet/ Wall Intersection**

- Applicable references: IBC 1405.3, IRC R703.8.
- Beams and parapets that intersect with high walls are susceptible to water intrusion issues.
- This is best addressed by fabricating a saddle flashing that can be installed prior to the cap flashing/ coping..
- Saddle flashing can be installed prior to installing the roofing membrane on the parapet or after as illustrated.
- Saddle flashing should be installed over stucco for best results.

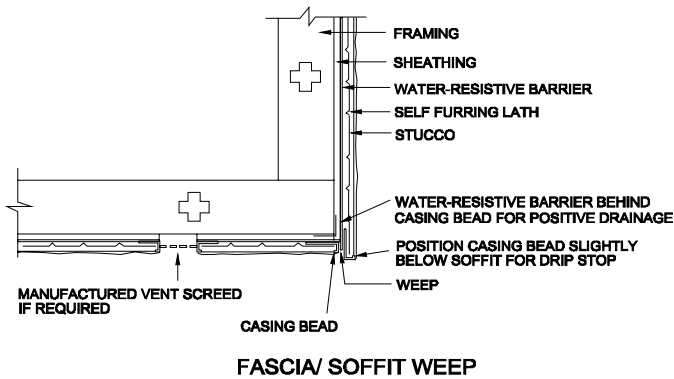

**Fascia/ Soffit Weep**

- Provides means of weeping incidental moisture at interface of soffit.
- Projection of casing bead below soffit plane breaks surface tension for natural drip stop.
- Vent screed necessary only if unconditioned air space above soffit.
- Note that water-resistant barrier is positioned behind flange of casing bead at fascia for positive drainage.

**Soffit Vent/ Weep Screed**

- Manufactured component integrates vent with weep function.
- Note that water-resistant barrier wraps onto flange of component for positive drainage from fascia to daylight.

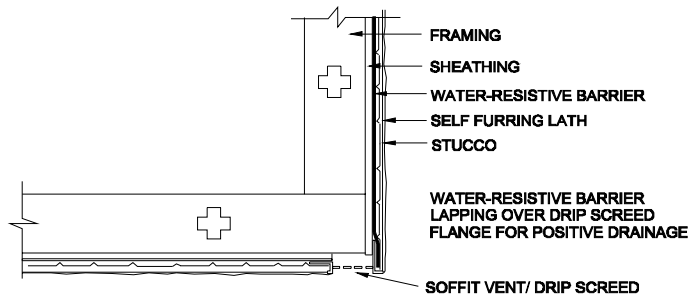



# General Notes

- Plywood and OSB sheathing substrates should be classified as Exposure 1 or Exterior Grade.
- It is recommended that multistory wood frame construction include expansion joints at floor lines to compensate for wood shrinkage and structural compression. These issues however can be mitigated by engineered structural components that are more stable than dimensional lumber.
- It is recommended that wood framing and wood based sheathing be reasonably dry with a moisture content of 19% or less when the water-resistant barrier and lath are installed.
- It is recommended that wood based sheathing panels be installed in accordance with APA requirements, with 1/8 inch spaces between all meeting panel edges.
- It is recommended that the building be carrying 90% of its dead load, prior to the installation of the stucco.
- Steel framing (on 16" centers) should be a minimum 3 1/2 inches wide with a minimum thickness of .0329 inches (20 gauge).
- The design deflection criteria for the structural system that the stucco system will be attached to must be L/360.
- A framing inspection should take place prior to a lath inspection. Appropriateness of flashings, treatments of penetrations and rough openings should be evaluated at that time.
- Wall penetrations such as electrical outlets, plumbing and vents should be completed and properly flashed or integrated to the water-resistive barrier prior to lath and stucco installation.
- Water-resistive barriers that have been adulterated by excessive exposure or damaged by tearing should be replaced prior to the application of stucco.
- Water-resistive barriers should be installed with staples that do not protrude through the back side of the sheathing.
- Water-resistive barrier should be installed flat and taut to the substrate surface.
- Lathers do not install windows. However, water-resistive barriers should be properly integrated with flashings for positive drainage.
- All flashings and water-resistive barriers should be installed for positive drainage.
- Metal flashing materials should be a minimum 26 gauge galvanized sheet metal or anodized, coil coated or painted aluminum.
- All trim accessories should be galvanized steel, zinc alloy or anodized aluminum.
- Trim accessories with an extended lip/ embedment flange should be used to key stucco to the component.
- Joinery of abutting ends of trim accessories should be spliced or lapped and sealed with appropriate sealant.
- Joinery of control joint intersections should be spliced or lapped and sealed with appropriate sealant.
- Joinery of flashing sections should be appropriately lapped, sealed and mended together by application of sealants, adhesive backed membrane or other appropriate means of continuity.
- Types of control and expansion joints if used, should be delineated on the contract drawings.
- The water-resistive barrier should remain unbroken behind control and expansion joints.
- Expansion joints when delineated on the contract drawings, should be located at points where significant building movement is anticipated: Wall penetrations, structural plate lines, junctures of dissimilar substrates, existing construction joints (such as in brick or block), columns and cantilevers.
- Installation of lath to concrete and concrete masonry units with drill and drive fasteners, power or powder actuated fasteners should be in accordance with manufacturer's recommendations.
- Pullout resistance of drill and drive fasteners, power or powder actuated fasteners should meet the requirements of the fastener manufacturer.
- If there is any question about the effectiveness of the pullout strength of drill and drive fasteners, power or powder actuated fasteners into concrete or concrete masonry block, a sample testing is recommended.
- Because stucco is a like-kind material to concrete or concrete block substrates, expansion joints in stucco in direct application over these substrates are dictated by whether a joint occurs in the substrate itself.

# Additional Rule Changes in the 2007 Minnesota State Building Code

Note: What follows are rule changes that were adopted in the residential section (IRC) of the 2007 Minnesota State Building Code. They are provided for informational purposes only.

## Section R613.1.

IRC Section R613.1 is amended to read as follows:

**R613.1 General.** This section prescribes performance and construction requirements for exterior window systems installed in wall systems. Windows and doors shall be installed in accordance with the manufacturer's installation instructions. Installation instructions shall be provided by the manufacturer for each exterior window or door type.

Subp. 2.

Section R613.2.

IRC Section R613.2 is deleted in its entirety.

## R202 Definitions

**Flashing.** Approved Corrosion-resistive material provided in such a manner as to deflect and resist entry of water into the construction.

**Kick-out Flashing.** Flashing used to divert water where the lower portion of a sloped roof stops within the plane of an intersecting wall cladding.

## R703.8 Flashing (kick-out flashing is now required)

9. Where the lower portion of a sloped roof stops within the plane of an intersecting wall cladding, in such a manner as to divert or kick-out water away from the assembly.

**R903.2.2 Kick-out flashing/ diverter.** A kick-out flashing shall be installed where the lower portion of a sloped roof stops within the plane of an intersecting wall cladding, in such a manner as to divert or kick-out water away from the assembly.

**R703.7.4.3 Mortar or Grout Fill.** As an alternate to the air space required by section R703.7.4.2, mortar or grout shall be permitted to fill the air space. When the 1-inch (25.4 mm) space is filled with mortar, a weather-resistant membrane or building paper as described in sections R703.2 or R703.6.3 is required over studs or sheathing. When filling the air space, it is permitted to replace the sheathing and weather-resistant membrane or asphalt-saturated felt paper with a wire mesh and approved paper or an approved paper-backed reinforcement attached directly to the studs.

**R703.7.4.4 Masonry veneer on sheathed substrates.** On sheathed substrates, a corrosion-resistant, self furring expanded metal lath shall be installed over the weather-resistant membrane or building paper with appropriate fasteners as described in section R703.6.1. Fasteners shall penetrate wood supports a minimum of 1-inch.

**Minnesota Lath and Plaster Bureau  
820 Transfer Road  
St. Paul, MN 55114**

**Phone (651) 645-0208  
Fax (651) 645-0209  
www.mnlath-plaster.com**

