

NAAMM
STANDARD

EMLA 920-09

METAL LATHING AND FURRING



NAAMM EMLA 920-09
December 2009

GUIDE SPECIFICATIONS FOR EXPANDED METAL LATHING AND FURRING

Fifth Edition

NAAMM EMLA 920-09
December 2009



METAL LATHING AND FURRING

EMLA

A Division of

NAAMM

NATIONAL ASSOCIATION OF
ARCHITECTURAL METAL MANUFACTURERS

DISCLAIMER

This manual was developed by representative members of the Expanded Metal Lath Association Division of the National Association of Architectural Metal Manufacturers (EMLA) to provide information and guidance on the manufacture of metal lath specifications. This manual contains advisory information only and is published as a public service by NAAMM and its Division. **NAAMM AND ITS EMLA DIVISION DISCLAIM ALL LIABILITY OF ANY KIND FOR THE USE, APPLICATION, OR ADAPTATION OF MATERIAL PUBLISHED IN THIS MANUAL.**

National Association of Architectural Metal Manufacturers
800 Roosevelt Road — Glen Ellyn, Illinois 60137 — 1-630-942-6591
Fax 1-312-332-0706 — Website: www.naamm.org

Copyright © 1981, 1984, 1986, 1991, 2003, 2009
By National Association of Architectural Metal Manufacturers, All Rights Reserved

HOW TO USE THESE SPECIFICATIONS

These specifications are a guide for the specification writer, inspector, and contractor concerned with the aspects of metal lathing and furring for plastered construction. They provide detailed information about many metal lath and plaster assemblies. In some instances, certain sections may not be applicable, however, Sections 1 through 7 are pertinent to all other sections and must be considered. Sections 6 & 7 contain requirements that apply to all others and should be included in any specifications prepared using this document as a basis.

Commentaries and explanatory notes, diagrams, etc. are inserted within the text where applicable and italicized. Appendix A provides supplementary information and details.

This specification covers the recommended minimum requirements for lath and furring. Other materials may be used provided their physical characteristics and durability under condition of usage are at least equal to those described.

TABLE OF CONTENTS

1. Scope.....	1
2. Referenced Documents	1
ASTM Standards.....	1
Federal Specifications.....	1
3. Definitions	1
4. Delivery of Materials	1
5. Storage of Materials.....	1
6. Materials, General.....	1
7. Installation, General.....	2
8. Metal Lathing on Exteriors (Stucco): Materials.....	4
9. Metal Lathing on Exteriors (Stucco); Installation	5
10. Non-load Bearing Steel Stud Partitions	
With Metal Lath Both Sides: Materials.....	6
11. Non-load Bearing Steel Stud Partitions	
With Metal Lath Both Sides: Installation	6
12. Metal Furring for Walls (Covered One Side): Materials	7
13. Metal Furring for Walls (Covered One Side): Installation.....	7
14. Direct Attached Furring: Materials	8
15. Direct Attached Furring: Installation.....	8
16. Metal Lath on Wood Studs: Material.....	8
17. Metal Lath on Wood Studs: Installation	8
18. Control Joints: Materials	8
19. Expansion Joints: Installation.....	8
20. Contact Ceilings: Materials	10
21. Contact Ceilings: Installation.....	10
22. Furred Ceilings: Materials	10
23. Furred Ceilings: Installation	12
24. Suspended Ceilings: Materials	12
25. Suspended Ceilings: Installation	12
26. Beam Boxes: Materials	14
27. Beam Boxes: Installation.....	16
28. Column Furring: Materials.....	16
29. Column Furring: Installation.....	16
30. Metal Lath Reinforcement for Plaster Bases	
Other than Metal Lath: Materials	17

31.Metal Lath Reinforcement for Plaster Bases.....	18
Design Assumptions and References	18
Appendix A	20
Ties and Splices	20
Lathing and Furring Connections	21
Penetration Flashing Recommendations.....	24
Control Joints/Expansion Joints	25
Appendix B - Design Considerations	28
General Notes	33
Lathing and Stucco Terminology	34

SPECIFICATIONS FOR METAL LATHING AND FURRING

1. SCOPE

This specification covers the minimum requirements for lathing and furring to receive full thickness plaster or stucco as specified in ASTM C842 and C926.

Where a specific degree of fire resistance is required, details of construction shall be in strict compliance with reports and appropriate tests.

2. REFERENCED DOCUMENTS

ASTM Standards

A1008-00 Standard Specification for Steel, Sheet, Cold-Rolled, Carbon, Structural, High-Strength: Low-Alloy and High-Strength Low-Alloy with Improved Formability.

A653/A653M (metric) Commercial Quality galvanized steel replaced A526.

A641/A641A Specification for Zinc-Coated (Galvanized) Carbon Steel Wire.

A1011/A1011M (metric) Standard Specification for Steel, Sheet, and Strip, Hot-Rolled, Carbon Structural, High-strength Low-Alloy and High Strength Low Alloy with Improved Formability. Replaced A569.

B69 Rolled Zinc Specification.

C645 Standard Specification for Nonstructural Steel Framing Members.

C842 Specification for Application of Portland Cement Based Plaster.

C847 Specification for Expanded Metal Lath.

C926 Specification for the Application of Portland Cement Plaster.

C954 Specification for Steel Drill Screws for the Application of Gypsum Panel Products or Metal Plaster Bases to Steel Studs from 0.033 in. to 0.112 in. in Thickness.

C1002 Specification for Steel Drill Screws for the Application of Gypsum Panel Products or Metal Plaster Bases.

C1063-08 Standard Specification for Installation of Lathing and Furring to Receive Interior and Exterior Portland Cement-Based Plaster.

Federal Specifications

UU-B-790a Building Paper, Vegetable Fiber, (Kraft, Waterproofed, Water Repellent and Fire Resistant).

3. DEFINITIONS

3.1 Plaster trim, for the purposes of this specification, shall mean all parts or assemblies used in

conjunction with metal lath and plaster construction to establish grounds, reinforcement, boundaries, stress relief or isolation, aesthetic appeal or to fulfill a utilitarian function principally designed to augment the finished plaster or stucco installation. They are generally characterized by such products as corner beads, casing beads or plaster stop, control joints or expansion joints, foundation weep screeds, drip screeds, reveals, and ventilation screeds or any other members deemed necessary to complement the function of the primary plaster assembly.

4. DELIVERY OF MATERIALS

4.1 All materials shall be delivered in the original packages, containers or bundles bearing the brand name and manufacturer's (or supplier's) identification.

5. STORAGE OF MATERIALS

5.1 All materials shall be kept dry, preferably by being stored inside and protected from damage to materials or packaging for accessories. Where necessary to store lath outside, materials shall be stacked off the ground, supported on a level platform, and protected from the weather and surface contamination and damage to ends, edges or surfaces.

6. MATERIALS, GENERAL

6.1 Metal Lath- as specified in ASTM C847, with or without paper backing, shall be fabricated from hot dipped galvanized steel with a minimum G60 zinc coating.

Use of copper bearing steel for metal lath is now obsolete and no longer should be cited in current specifications.

The term galvanized refers to carbon steel that has been coated or galvanized with zinc by the hot-dip process.

The term zinc alloy denotes material comprised of almost pure zinc throughout the thickness of the product, with only enough alloy elements for workability.

Self-furring of diamond mesh metal lath (approximately 1/4 inch) may be accomplished by rolling intermittent dimples or continuously embossed ribs into the mesh. These ribs run longitudinally down the length of the sheet of lath.

6.2 Plaster Trim- All trim to be anchored in the plaster may have perforated, expanded, or solid flanges shaped so as to permit full embedment

in the plaster to provide a means for accurate alignment, and to secure attachment of the trim to the plaster base. This helps to avoid cracks in the stucco. Trim shall be designed to receive or to accommodate application of the specified plaster thickness.

- 6.3 Plaster trim shall be fabricated from hot-dipped galvanized steel or zinc alloy.
- 6.3.1 Galvanized steel, with a minimum G60 coating as specified in ASTM A653, and a thickness of .0172 as specified in ASTM C1063
- 6.3.2 Zinc alloy, as specified in ASTM B-69.
- 6.4 Plaster trim thickness shall be as follows:

TABLE 1

Accessory	Base Material	
	Steel (in.)	Zinc Alloy (in.)
Corner Beads	0.0172	0.0207
Cashing Beads	0.0172	0.0207
Weep Screeds	0.0172	0.0207
Control Joints	0.0172	0.0180

- 6.5 Zinc alloy plaster trims shall be used for installations where abnormal corrosion is possible due to high humidity and continual moisture exposure as in bath and shower rooms, greenhouses, swimming pool areas, etc., or where adverse atmospheric conditions may exist, (high saline content or acid rain) such as in coastal regions or heavy industrial areas.
- 6.6 Corner reinforcement (1.75 lb/sq. yd.) galvanized expanded metal strip lath bent to form corner reinforcement. It shall have legs of not less than 2 in. in width.
Cornerite in flat configuration (strip-lath) may also be applied diagonally across corner as reinforcement of concentrated stress areas on flat surfaces, such as at corners of door or window openings with strip width not less than 4 in.
- 6.7 Cold-rolled furring channels shall have a minimum galvanized G60 coating per ASTM A653 and physical properties shall be as follows: they shall be formed from steel having a minimum 33,000 psi yield strength, minimum flange width of 1/2 inch minimum, 0.0538 in. minimum bare steel thickness and have the following minimum weights in pounds per 1000 linear feet.

Sizes (in)	Weight (galvanized)
3/4	277
1 1/2	414
2	506
2 1/2	597

- 6.8 Wire as specified in ASTM A641, galvanized, soft temper class 1 coating weight
- 6.9 Rod and Strap hangers shall be of mild steel per ASTM A1008 with rust inhibitive coating or galvanized commercial quality steel per ASTM A653 minimum G60 coating.
- 6.10 Clips shall be formed from galvanized steel wire as specified in ASTM A641 from hot-dipped galvanized steel as specified in ASTM A653.
- 6.11 Nails shall be galvanized roofing nails (type II, style 20) or galvanized common nails (type II, style 10) as specified in Fed. Spec. FF-N-105B and as shown in Table 2:

**TABLE 2
NAILS**

Roofing Nails- Type II, Style 20

Shank (in)	Head (in)	Length (in)
0.120	0.438	1
0.120	0.438	1 1/2
0.120	0.438	1 3/4

Common Nails- Type II, Style 10

	Shank (in)	Head (in)	Length (in)
6d	0.113	0.266	2
8d	0.131	0.281	2 1/2
12d	0.148	0.312	3 1/4
16d	0.162	0.344	3 1/2
30d	0.207	0.438	4 1/2

- 6.12 Staples for attaching metal lath to wood supports shall be 0.054 in. (16ga) round or flattened with min. 3/4 in. crown. (see 8.4.2.2)
- 6.13 Screws shall be self-drilling or self-taping as required in accordance with ASTM C954 or C1002. (See 8.4.2.3)
- 6.13.1 For attaching metal lath to steel framing, they shall have a 7/16 in. diameter pan wafer head and a 0.120 in diameter (#8) shank long enough to penetrate framing a minimum of 3/8 in.
- 6.13.2 When attaching lath to horizontal metal support members lath shall be attached with screws described above and must contact at least three strands of lath. This may require the use of 1" O.D. X 1/4" I.D. X 16 ga. cut washers.

7. INSTALLATION, GENERAL

Metal lath shall be of appropriate type and weight for the application (horizontal or vertical) and the spacing of supports as set forth in Tables 3 & 4.

**TABLE 3
VERTICAL ASSEMBLIES (WALLS) MAXIMUM
SUPPORT SPACING, in.**

Lath Type	Lath Wt. lbs/sq yd)	Wood ^A Studs	Masonry/ Concrete	Metal ^A Studs
Dia. Mesh	2.5	16	16	16
Dia. Mesh	3.4	16	16	16
Flat Rib	2.5	16	16	16
Flat Rib	3.4	19	19	19
* 3/8 Rib	3.4	24	24	24

* 3/8 Rib Lath is not recommended for vertical applications as it may cause thickness variations leading to stucco cracking.

**TABLE 4
HORIZONTAL ASSEMBLIES (SOFFITS)
MAXIMUM SUPPORT SPACING, in.**

Lath Type	Lath Wt. lbs/sq yd)	Wood ^A Studs	Masonry/ Concrete	Metal ^A Studs
Dia. Mesh	2.5	12	12	12
Dia. Mesh	3.4	16	16	6
Flat Rib	2.5	16	16	16
Flat Rib	3.4	19	19	19
3/8 Rib	3.4	24	24	24

Notes:

^A For lath over solid sheathing, attachments must extend through lath and sheathing into the wood or metal supports⁴.

^B Attach metal lath to concrete or masonry surfaces with attachments,⁵ not to exceed 7 in. apart in a line running across the short dimension of the sheet. Rows of fasteners shall be spaced 16 in. on center.

^C It is recommended that only 2.5-lb/sq. yd. or heavier lath be used on exterior applications. Over sheathed walls framing and attachments may be extended to 24 in. on center and self-furred lath must be utilized. *Note: 1.75 expanded metal lath is not recommended for 3-coat stucco.*

^D Lath does not need to be furred on supports having a surface of less than 1 5/8 in. bearing on the lath.

^E Self-furring lath shall be used.

^F Fastener length at least 3/4 in. penetration into wood supports.

^G Six power or powder activated fasteners are required per sheet in addition to stub nails which must be at least 3/4 in. in length. Power fasteners located in each corner and at mid point of long dimension of the sheet edge. Power actuated fasteners can be used for all connections and should have a minimum 0.145 in. shank. All fasteners should have a minimum 7/16 in. wide head or use a washer to contact at least three lath strands. (Stub nails may be used to attach the balance of the field of each sheet.)

7.1 Install metal lath with its long dimension crossing supports at a right angle. Install rib metal lath with ribs against the supports. (See illustration)

Attach metal lath to supports not to exceed 7 in. on center along all supports. Wire tie metal lath at the side laps with single loop of 0.043 in. (18 ga.) galvanized not to exceed 9 in. spacing. That is, one tie between supports for 16 in. spacing and two ties for 24 in. support spacings.

**RIB LATH
INSTALLATION**

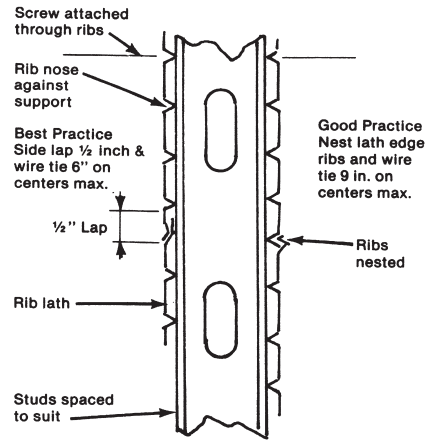

7.2 Lap diamond mesh and flat rib metal laths at sides at least 1/2 in. Lap 3/8 in. rib lath (ending with edge rib) by either nesting edge ribs or (if ending with flat lath edge) lapping sides at least 1/2 in. End laps should occur over framing members or supports.

7.3 To lap paper backed lath, it is necessary that there be lath to lath contact as opposed to lath to backing (paper to lath) contact and that the backing be extended behind the metal to metal lap. Most paper-backed lath is now sold with off set paper that allows for easier installation in the proper fashion.

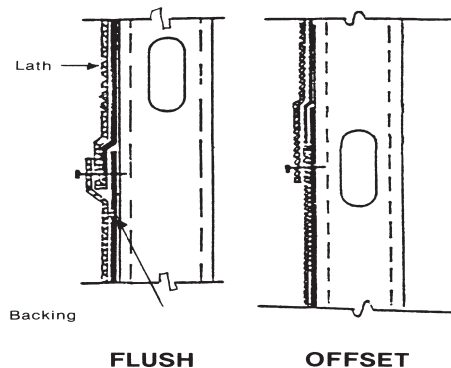

7.4 To prevent moisture penetration into exterior walls, the over-lapping backing shall be ship or roof lapped so that it extends downward on the lath side of the lap (paper over paper, metal over metal), shedding any water down the wall to the foundation weep screed to facilitate drainage.

Wall ceiling junctures or intersections can be treated either as restrained (unmoving) or unrestrained (floating) construction.

7.5 Restrained Construction.

7.5.1 Where diamond mesh metal lath is used on abutting ceilings, and walls or partitions bend lath into internal corner and carry around the corner at least 3 in. onto adjoining lath surface before lapping and fastening; or but lath into corner and apply Cornerite over the abutting lath juncture.

When using cornerite or bending lath into internal corners for restrained construction, do not fasten cornerite or lath to support framing at terminal end but allow it to float by attaching to adjacent lath only. For lath bent into and carried from internal corner, do not fasten such lath to its corner entry supports closer than 6 in. from corner.

7.5.2 Where rib lath is used on abutting ceilings, and wall or partitions, butt lath into corner and apply cornerite over abutting lath juncture.

7.6 Unrestrained Construction

7.6.1 Install casing bead or control joint along plaster surfaces intersection. If casing bead is used, hold bead face sufficient distance from abutting surface to suit backer rod and caulking used to fill gap (approx. 3/8 in.).

The discontinuity of the unrestrained construction is particularly advantageous where differential movement may be expected between intersecting plaster membranes. Also, design consideration should be given to the isolation of load carrying building components such as columns, beams, floors, etc. from non-load bearing components.

7.7 Control joints and expansion joints shall be designed and installed in a manner to permit the plaster membrane to expand and contract freely without inducing excessive stress in the plaster.

See Sections 18 & 19 for specific information on material selection and installation.

7.8 Where abutting surface is not to be plastered, terminate plastered surface with a casing bead (plaster stop) of suitable grounds to match stucco thickness.

7.9 attachments shall be firm enough to hold trim in place during plastering.

8. METAL LATHING ON EXTERIORS (STUCCO): MATERIALS

8.1 Metal lath shall be of the appropriate type and weight for the application (vertical or horizontal) and spacing of supports as set forth in Tables 3 & 4, Section 7)

8.2 Flashing (usually water proof asphalt saturated paper strips in combination with metal flashing elements) shall be of a noncorrosive type, installed prior to lathing, and located as follows: (See Appendix)

8.2.1 At the tops of all openings in the stucco.

8.2.2 Along the sides of all openings.

8.2.3 Where trims project under copings and sills.

8.2.4 At intersections of walls and roofs.

8.2.5 Under built-in gutters.

8.2.6 Around all roof openings.

8.2.7 At all places where flashing can be used to prevent water from getting behind the stucco membrane.

8.2.8 Behind all foundation weep screeds, which must be located at the bottom of all framed walls. Also, used in some cases over window head flashing and at stucco wall to roof junctures.

8.3 Attachments- Vertical Assemblies:

8.3.1 *On steel:*

8.3.1.1 Wire Ties- 0.043 (18 ga) diameter galvanized wire per ASTM A641/641M.

8.3.1.1 Screws-Self-drilling, self-tapping, #8 shank, 7/16 in. pan wafer head, 1/2 in. or long enough to project a minimum of 3/8 in. through the support, galvanized or equivalent.

8.3.2 *On wood*

8.3.2.1 Nails - as specified in 6.11- barbed or etched, galvanized roofing nails, 0.120 in. (11 ga.) shank diameter, 7/16 in. diameter head, which provides for penetration into supports of at least 1 in., or 0.113 in. (11 1/2 ga.), 6d, 2 in. long galvanized common nails driven at least half way in and bent over to catch at least three strands of lath.

8.3.2.2 Staples - round or flattened 0.062 in. diameter (16 ga) wire, 3/4 in crown; 7/8 in. lets for flat laths, or 1 1/4 in legs for 3/8 in. rib lath with minimum penetration into support of 3/4 in. engaging not less than three strands of lath.

8.4.1 On steel

8.4.1.1 Wire Ties- Direct attachments for securing metal lath shall be at least one loop of 0.054 (16 ga.) diameter galvanized, annealed, steel wire or two loops of 0.043 in. (18 ga) diameter galvanized, annealed, steel wire.

8.4.1.2 Screws- as specified in 6.13. Maximum spacing of 7 inches on center shall be applied for diamond mesh lath and into each rib for rib lath for plaster thicknesses of 1 in. or less. The screw shall pass through but not deform the rib.

8.4.2 On wood

8.4.2.1 Nails- Barbed or etched, galvanized roofing nails, 0.120 in. (11 ga.) shank diameter, 7/16 in. diameter head, which provides for a penetration into supports of at least 1 1/2 in.

8.4.2.2 Staples-round or flattened 0.054 in. diameter (16 ga) wire, 3/4 in crown; 7/8 in. lats for flat laths, or 1 1/4 in legs for 3/8 in. rib lath with minimum penetration into support of 3/4 in. engaging not less than three strands of lath.

8.4.2.3 Screws- as specified in 6.13. Maximum spacing of 7 inches on center shall be applied for diamond mesh lath and into each rib for rib lath for plaster thicknesses of 1 in. or less. The screw shall pass through but not deform the rib. Screws shall penetrate at least 5/8 in. into the support and have a min. 7/16 in. diameter head.

8.4.3 On concrete: Attachments for securing metal lath directly to concrete shall be attached with preinstalled wire of 0.068 diameter (14 ga). They shall be provided with a loop or other preinstalled means for attachment. For direct attachment of lath to concrete surfaces the following method is also employed. Six power or powder activated fasteners are required per sheet in addition to stub nails which must be at least 3/4 in. in length. Power fasteners located in each corner and at mid point of long dimension of the sheet edge. Power actuated fasteners can be use for all connections and should have a minimum 0.145 in. shank. All fasteners should have a minimum 7/16 in. wide head or use a washer to contact at least three lath strands. Stub nails can be used for balance of field.

8.5 Lath backing- When supplied as an integral part of the lath, shall be water-resistant asphalt saturated paper meeting Federal Specification UU-B-790a, Type 1, Grade D, vapor permeable.

9. METAL LATHING ON EXTERIORS (STUCCO): INSTALLATION

9.1 Steel Frame Construction

See sections 26 through 29 for lathing steel beams and structural columns.

9.1.1 Install self-furring lath to provide clearance for "plaster keys" to form. (Furring offset of lath not required on supports having bearing surface of 5/8 in. or less)

9.1.2 Stagger end laps of lath from course to course.

9.1.3 Return lath 3 in. around internal corners or use cornerite.

9.1.4 Carry lath down to the angular edge of the foundation screed to cover the building paper and back flange of the weep screed.

9.2 Wood Frame Construction

9.2.1 Install self-furred lath to provide clearance (approximately 1/4 in.) for "plaster keys" to form. (Furring not required on supports with bearing surface width of 1 5/8 in. or less).

9.2.2 Attach metal lath to wood supports with nails or staples spaced not to exceed 7 in. on centers.

9.2.3 Common nails shall be driven in half way and bent over to engage at least three strands of diamond mesh lath or over the ribs of flat or 3/8 in. rib lath.

9.2.4 Roofing nails shall be driven flush with the surface of the lath so as to engage at least three strands of diamond mesh lath or driven through the ribs of flat or 3/8 in. rib lath without deforming the rib.

9.2.5 Staples shall be driven in so as to engage at least three strands of diamond mesh lath or over the ribs of flat or 3/8 in. rib lath without deforming the rib.

9.2.6 Stagger end laps from course to course.

9.2.7 Start metal lath one stud away from corner, (see 7.5 commentary) or use cornerite for internal corners and corner bead for external corners. The second option is the most commonly employed.

9.2.8 Carry lath down to the angular edge of the foundation screed to cover the building paper and back flange of the weep screed.

9.3 Sheathed Construction or Overcoating

9.3.1 In those areas that only require one layer of paper lath with integrally applied paper is not recommended. In these areas paper should be installed separately to ensure water integrity.

Metal lath should be used as reinforcement over all surfaces (old brick, painted block, sheathing, etc.) that do not provide a satisfactory bond for stucco. Special consideration must be given to attachment of the lath to these surfaces.

9.3.2 In those code jurisdictions requiring two layers of building paper between lath and wood based sheathing, the water resistant backing incorporated into the appropriate lath will suffice for one of the two required.

9.3.3 Where building paper is required, it shall be fastened to the sheathing or surface being over coated with each course overlapping the course below at least 2 in. on the side lap and the end lap of backing shall be at least 2 in. (some jurisdictions require end laps up to 6 inches.

9.3.3.1 A 1/8 in. space shall be left between all edges of adjoining wood sheathing for expansion.

9.3.4 Install self-furring lath to provide clearance of approximately 1/4 in. for "plaster keys" to form.

9.3.5 Stagger end laps of lath from course to course.

9.3.6 Start metal lath one stud away from corner, (see 7.5 commentary) or use cornerite for internal corners and corner bear for external corners. The second option is the most commonly employed.

9.3.7 Carry lath down to the angular edge of the foundation screed to cover the building paper and back flange of the weep screed.

10. NON-LOAD BEARING STEEL STUD PARTITIONS WITH METAL LATH BOTH SIDES: MATERIALS

10.1 Metal lath shall be of the type and weight for the spacing of supports as set forth in Table 3, Section 7.

Consult individual manufacturers for load bearing stud capabilities and application.

10.2 Interior non-load bearing studs shall be minimum 0.033 in. thick (design thickness) (20ga.) galvanized steel studs.

10.3 Studs shall be of the size and spacing for the simple span height of the partition as set forth in Table 5.

**TABLE 5
PARTITION HEIGHTS**

Overall Partition Thickness (in.)	Stud Size (in.)	Stud Spacing		
		24in.	16in.	12in.
3 1/8	1 5/8	6'4"	7'3"	8'
4	2 1/2	8'10"	10'1"	11'1"
5 1/8	3 5/8	11'5"	13'1"	14'5"
5 1/2	4	12'8"	14'7"	16'0"
7 1/2	6	17'7"	20'2"	22'2"

A. Based on 5 PSF transverse load, L/360 maximum deflection, and non-composite design.

B. Plaster thickness is 5/8 in. from finished face to face of lath (3/4 in. from finished face to face of stud.) For 3/8 in. rib metal lath both sides, partition thickness is 1/2 in. greater than when installed with diamond mesh lath. 3/8 in rib lath is not generally recommended for vertical applications.

C. 0.033 in. thick (20ga.) galvanized steel with minimum 1 1/4 in. flanges and 3/16 in. return (lips). It is recommended that no studs lighter than this be considered for supporting lath and plaster assemblies.

10.4 Horizontal stiffeners shall be 1 1/2 in. cold rolled channels for studs to 6 in. deep.

11. NON-LOAD BEARING STEEL STUD PARTITIONS WITH METAL LATH BOTH SIDES: INSTALLATION

11.1 Attach track to concrete with concrete penetrating nails, power driven fasteners, or expansion drives 24 in. o.c.

11.2 Attach track to steel studs with screws.

11.3 Extend metal stud to a metal lath ceiling and wire tie to ceiling furring and or lath, or

11.4 Extend stud above ceiling and attach to track, which has been fastened to basic structure above ceiling.

11.5 Where track cannot be used to hold each stud in place, attach clip angle to structure with screws, nails or power-actuated fasteners. Use two fasteners for each connection.

11.6 Attach studs to track or clip angles with screws. Use two fasteners for each connection.

11.7 Partitions shall be stiffened by installation of horizontal bridging at vertical spacing not to exceed 5 ft. o.c. Stiffeners shall be attached to each stud by screws or welds.

11.8 Frame at door openings by installing studs at each jamb.

- 11.9 Install studs at metal doorframes by screwing, bolting or welding to all jamb anchors.

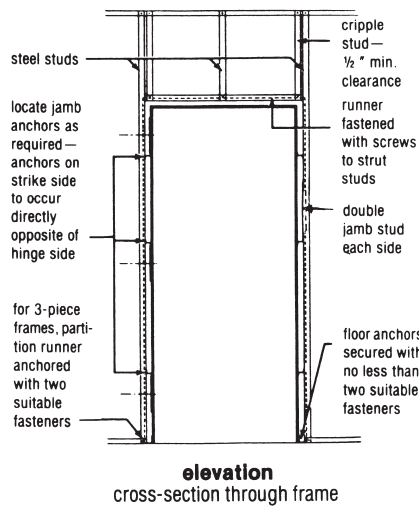

- 11.10 Install an additional jamb stud on each side by screwing or welding stud toe-to-toe or back-to-back to the first stud.
- 11.11 Place cut length of track over head of door between jamb studs. Attach track to studs at each end by cutting the track flanges and bending the web at the cuts and screwing to studs or by using clip angles or welding.
- 11.12 Install studs a cripple studs 24 in. maximum o.c. depending on the lath used over the head of the door frame, between cut length of track and top track.
- 11.13 Insert metal lath as far as possible into the inside space of the metal frame, notching lath to pass around jamb anchors.
- 11.14 Attach studs to wood door jamb with screws.

12. METAL FURRING FOR WALLS (COVERED ONE SIDE): MATERIALS

- 12.1 Metal lath shall be of the type and weight for the spacing of supports as set forth in Table 3, Section 7.
- 12.2 Unbraced furring shall be of the type, size and spacing for the height of the assembly as set forth in table 6.

**TABLE 6
UNBRACED FURRING HEIGHTS
(COVERED ONE SIDE)**

Furring Type	Furring Size	Spacing		
		24"	16"	12"
Cold Rolled Chan.	1 1/2"	8'	10'	12'
Cold Rolled Chan.	2"	9'	11'	13'
Steel Stud (20 ga.)	1 5/8"	7'10"	8'	8'7"
Steel Stud (20 ga.)	2 1/2"	10'1"	11'6"	12' 6"

- 12.3 Horizontal stiffeners or bridging shall be not less than 3/4 in. cold rolled channel at 1/3 spans.
- 12.4 Concrete stub nails for attaching track, runners or studs shall penetrate concrete at least 3/4" If other fasteners such as power or powder-actuated fasteners are used, they shall provide attachment as strong as the concrete stub nails. (See appendix A for fastener strengths).

13. METAL FURRING FOR WALLS (COVERED ONE SIDE): INSTALLATION

- 13.1 Cold-rolled channels shall be attached to concrete by cutting the flanges of the channel at least 2 in. from the end, bending the section back and nailing or shooting the web of the channel to the concrete.
- 13.2 Steel studs shall be installed following the methods outlined in Section 11 as for partitions.
- 13.3 Horizontal stiffeners shall be spaced not to exceed 5 ft. on centers vertically with the upper and lower stiffeners not more than 6 in. from the floor and ceiling.

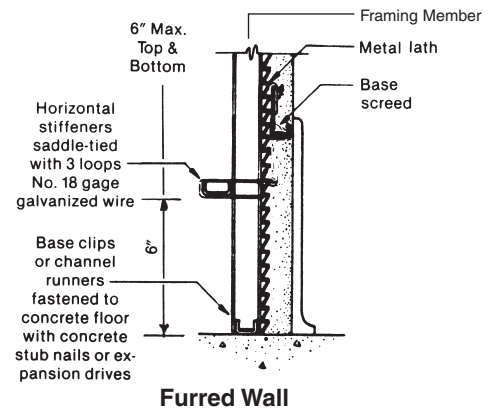

- 13.4 Stiffeners shall be at least 1/4 in. clear from the face of the wall.
- 13.5 Where furring abuts the underside of a concrete slab or runs parallel to and abuts load-bearing concrete beams or steel members, a slip or cushioning joint shall be provided so that loads will not be transferred to the furring.

For specifications and details of slip joints consult appropriated manufacturer's literature. Common joint construction generally includes track, runners, clip and casing bead used in combination with one or more sealing materials such as elastic caulking, compressible fiberboards and vinyl gaskets.

- 13.6 At door frames install casing bead at door frame to isolate the plaster membrane from shock loading.

- 13.7 Door frames shall not be supported by vertical furring.
- 13.8 Wood casings shall be specified that overlap the plaster at least 1 in.

14. DIRECT ATTACHED FURRING: MATERIALS

- 14.1 Metal lath shall be of the type, and weight for the spacing of supports as set forth in Table 3, Section 7.
- 14.2 Furring shall be 7/8 in. deep, galvanized steel hat channel, 0.0312 in. thick (20 ga.), with 1/2 in. nailing flanges and 1 1/4 in. face (attachment surface).
- 14.3 Attachment to wall shall be with concrete stub nails, powder or power driven fasteners or expansion drives at least 1 in. in length.
- 14.4 attachment of lath to hat channel shall be with self-drilling, self-tapping #8 shank, 7/16 in. pan wafer head screws, long enough to penetrate 3/8 in. through the support.

15. DIRECT ATTACHED FURRING: INSTALLATION

- 15.1 Hat channels shall be installed vertically and spaced not to exceed 16 inches on center for diamond mesh applications.
- 15.2 Hat channels shall be attached to wall with fasteners staggered and spaced not to exceed 12 in. o.c. along both sides of the channel. This is done so that no fastener on any nailing flange will exceed 24 in.

16. METAL LATH ON WOOD STUDS: MATERIALS

- 16.1 Metal lath shall be of the type and weight for the spacing of supports as set forth in Table 3, Section 7.
- 16.2 Attachments for metal lath shall be as specified in 6.11 and/or 6.12 and as follows:
 - 16.2.1 Nails - 1 in. long roofing nails or 6d 2 in. long common nails driven half way in and bent over. Three strands of lath should be in contact with the fastener.
 - 16.2.2 Staples-7/8 in. long legs for diamond mesh and flat rib laths and 1 1/4 in. long legs for 3/8 in. rib lath.

17. METAL LATH ON WOOD STUDS: INSTALLATION

- 17.1 Attach metal lath to wood studs with nails or staples spaced not to exceed 7 in. on centers driven at least 3/4 in. into the stud. When applying over sheathing fastener must be into framing members and long enough to pass through the sheathing and still penetrate the stud at least 3/4 in.
- 17.2 Common nails shall be driven in partially but sufficiently and bent over to engage at least three strands of diamond mesh lath or over the ribs of flat or 3/8 in. rib lath.
- 17.3 Roofing nails shall be driven in flush with the surface of the lath and engage at least three strands of lath or driven through the rib of flat and 3/8 in. rib laths.
- 17.4 Staples shall be driven into the framing member and lath so as to engage at least three strands of lath or over the ribs of flat or 3/8 in. rib laths.

18. CONTROL JOINTS: MATERIALS

- 18.1 Control joints shall be used to relieve stresses of expansion and contraction due to shrinkage and minor thermal movement in large plastered interiors or stuccoed exterior areas.
- 18.2 Control joints shall be specifically designed metal plastering accessories.
- 18.3 Material shall be galvanized steel (zinc coated carbon steel) or zinc alloy (nearly pure zinc), depending on the severity of exposure, manufactured in accordance with 6.3 through 6.5.
- 18.4 One-piece reveals are not considered control joints.

19. EXPANSION JOINTS: INSTALLATION

- 19.1 Expansion Joints (EJ) require that lath be discontinuous and attached on both sides of the cut in the lath. Expansion joints consist of two or three piece assemblies. Expansion joints govern over control joints when structural movement is anticipated. Expansion joints should run continuous with control joints abutting. In seismic zones expansion joints are recommended at all floor lines. Water resistant barrier should run continuous behind the expansion joint and properly

lapped in a weather bond fashion to allow moisture to escape the stucco assembly. Expansion joints should be sealed at all inside/outside corners and termination points to prevent bulk water from entering the stucco assembly.

19.1.2 CONTROL JOINT: INSTALLATION

Water resistant barrier should run continuous behind control joints. Control joints should be sealed at inside/outside corners and termination points. Lath should be cut behind control joints and attached to framing members on either side of control joint. Control joints should then be attached with wire ties at 9" on center

Control joints are single piece accessories and are limited in their range of movement. Two-piece expansion joints provide greater movement.

Where sound and /or fire ratings are of prime consideration, adequate protection must be provided behind control joints.

Also, metal control joints should not be used with magnesium oxychloride cement plasters or plasters containing chloride additives. This applies to all metal accessories, as these chemicals will accelerate corrosion.

The stucco membrane should be isolated with control joints where construction changes radically within the plane of a partition or plastered surface areas or dimensions exceed prescribed area sizes.

- 19.2 Attach control joints to the cut edges of abutting lath sheets with wire ties unless a through wall expansion exists as described in 19.1.
- 19.3 In gypsum plaster ceilings install control joints to create panels no larger than 2500 sq. ft. with no dimension exceeding 50 ft.
- 19.4 For furring runs on the inside faces of exterior walls, install control joints not to exceed 30 ft. in either direction or where a through wall expansion occurs.
- 19.5 For exterior portland cement stucco, install control joints to create panels no larger than 144 sq. ft. for walls or 100 sq. ft. for ceilings. No dimensions shall exceed 18 ft. or a length to width ratio of 2 1/2 to 1.
- 19.6 Install control joints at all locations where panel sizes or dimensions change.

- 19.7 Joints shall extend the full width or height of the plaster membrane.

Where a plaster surface is finished flush with metal, metal door bucks should be grooved between the two dissimilar materials. Where stucco abuts any openings or dissimilar material other than inset door jams, stucco shall be terminated with a casing bead allowing room for backer rod and sealant placement. Where a plaster surface is finished flush with metal door bucks the plaster should be grooved between the two dissimilar materials or a casing should be used to isolate the jam from the stucco.

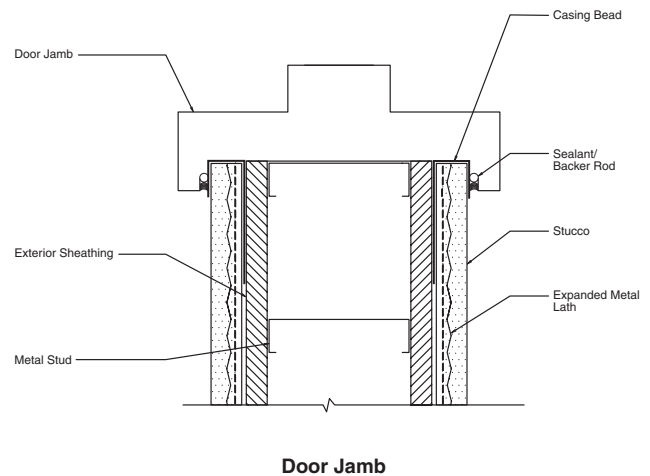

- 19.8 Less than ceiling height door frames shall have control joints extending to the ceiling from both top corners, or ceiling height door frames may be used as control joints.
- 19.9 If control joints are not used, additional reinforcement is required at the corners of openings such as strip lath placed at 45° to vertical to distribute stress concentration at the corners.
- 19.10 Where two casing beads (plaster stops) are employed as a control/expansion joint shall have a 6 in. to 10 in. strip of 25 mil. Self adhesive flashing centered under the joint.
- 19.11 The space between casing beads is to be filled with backer rod and highly durable elastic caulking compound formulated for such service.

With one-piece expansion joints the joint should be cleaned of all finish and nothing should be injected into the expansion opening of the joint.

Note: all joints or junctures of joint sections shall be embedded in a bed of caulk.

20. CONTACT CEILINGS: MATERIALS

- 20.1** Metal lath shall be of the type and weight for the spacing of supports as set forth in table 4, section 7.
- 20.2** Concrete- Attachments for securing metal lath to the underside of concrete joist shall be wire hairpins, hooks, shot pins or loops.
- 20.2.1** They shall be provided with a loop or other deformation for positive anchorage in the concrete, or they shall be attached with power, or powder actuated fasteners with at least a 1" length.
- 20.2.2** If loops are employed they shall be secured to the reinforcing steel before concrete placement.
- 20.2.3** Attachments shall be not less than 0.135 in. (10ga.) diameter wire when struck over or 0.068 in. (14ga.) when twisted as a tie.
- 20.2.4** Attachments shall be spaced at not more than 7 in. on center along the joists.
- 20.3** Steel- Attachments for securing metal lath to the underside of open web steel joists shall be not less than one loop of 0.054 in. (16ga.) diameter wire or two loops of 0.043 in. (18ga.) diameter wire.
- 20.3.1** Wire ties shall be spaced at not more than 7 in. apart along the joists.
- 20.4** Cold formed steel- Attachments to cold-formed steel joists shall be with #8 self-drilling, self-tapping, 1/2 in. long screws with 7/16 in. diameter pan wafer heads.
- 20.5** Wood – Attachments for securing diamond mesh and flat rib metal laths to the underside of wood joists shall be:
- 20.5.1** not less than 0.120 in. diameter (11ga.) shank, barbed roofing nails with 7/16 in. diameter heads, 1 in. long, or
- 20.5.2** not less than 0.054 in. diameter (16ga.) round or flattened wire, power driven staples with 3/4 in. crown, 7/8 in. legs.
- 20.6** For 3/8 in. rib lath, nails shall be at least 2 in. long driven half way in and bent over the rib, and staples at least 1 1/4 in. long driven over rib. The rib shall not be crushed or deformed.

21. CONTACT CEILINGS: INSTALLATION

- 21.1** Attach metal lath:

- 21.1.1** to concrete by twisting wire hairpins or loops (14ga.) under the lath, or by striking wire (10ga.) over or attach by shooting pins with 1/2 in. washers using power or powder actuated fasteners at least 1 in. long
- 21.1.2** to open web joists by twisting wire loops under lath
- 21.1.3** to wood joists by driving roofing nails or power driven staples flush with the surface of the lath holding it tightly against the lath and joists.

22. FURRED CEILINGS: MATERIALS

- 22.1** Metal lath shall be of type and weight for the spacing of supports (furring) as set forth in table 4, section 7:

**TABLE 7
MAXIMUM ALLOWABLE FURRING SPANS**

FURRING TYPE	SPACINGS		
	24in.	16in.	12in.
3/4 in. CRC	3'	4'	4'
Hat Channel (20 ga. Min.)	3'	4'	4'

- 22.3** Concrete – attachments for securing furring to the underside of concrete joist shall be wire hairpins, hooks, loops, or by power or powder actuated fasteners.
- 22.3.1** Concrete joists shall be provided with a loop or other deformation for positive anchorage in the concrete so as to develop full strength of the wire, or
- 22.3.2** They shall be secured to the reinforcing steel before concrete placement.
- 22.3.3** Attachments shall be not less than 0.068 in. (14ga.) diameter wire.
- 22.4** Steel – Attachments for securing furring to the underside of the open web steel joist shall be not less than one loop of 0.054 in. (16ga.) wire or two loops of 0.043 in. (18ga.) wire.
- 22.5** Steel – Attachments for securing hat channel furring to the under-side of cold-formed steel joists shall be #10 shank, self-drilling, self-tapping, pan wafer head screws, long enough to for clear penetration of 3/8 in.
- 22.6** Wood – Attachments for securing furring to the underside of wood joists shall be not less than one loop of 0.054 in., (16 ga.) wire or two loops of 0.043 (18 ga.) wire attached to nails. See detail "A".
- 22.7** Nails – as specified in Fed. Spec. FF-N-105B, Type II, Style 10, common nails.

CONTACT CEILING DETAILS

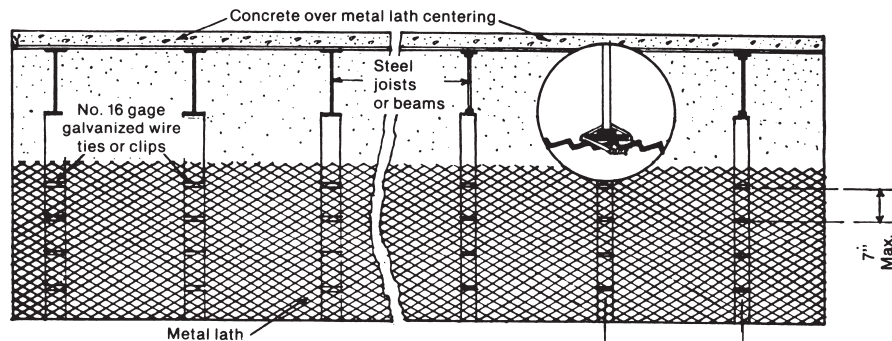
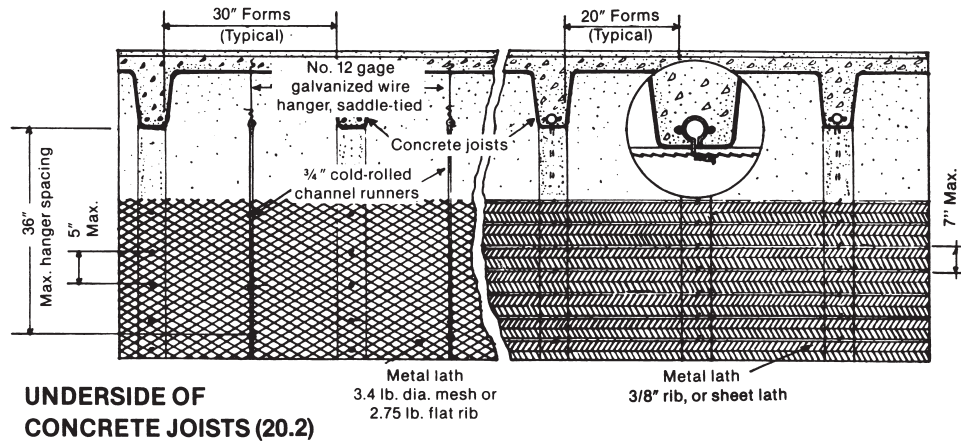

Type and Weight of Metal Lath	Max. Span of Metal Lath
3.4 lb. diamond mesh	16"
2.75 lb. flat rib	16"
3.4 lb. flat rib	19"
3/8" rib, or sheet lath	24"

See Detail "A"

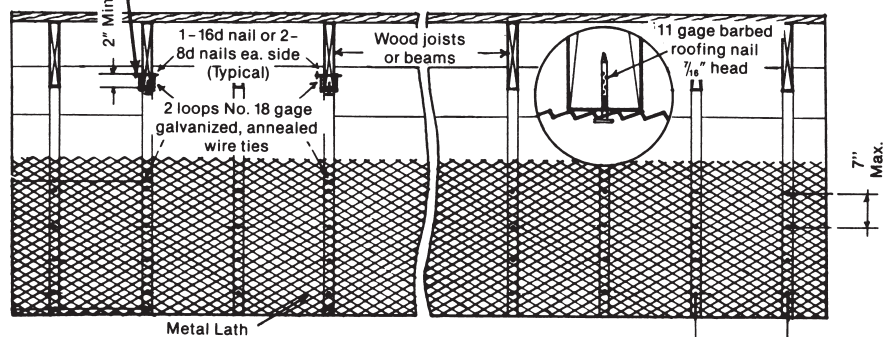

Type and Weight of Metal Lath	Max. Span of Metal Lath
2.5 lb. dia. mesh	12"
3.4 lb. dia. mesh or 2.75 lb flat rib	16"
3.4 lb. flat rib	19"
3/8" rib, or sheet lath	24"

Method of Fastening
11 gage barbed roofing nails 1 1/2" long
11 gage barbed roofing nails, minimum penetration 13/8"

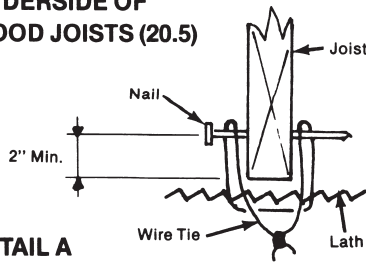

23. FURRED CEILINGS: INSTALLATION

- 23.1** Attach furring to concrete joists by twisting wire hairpins or loops under furring or mechanical attachment with power or powder actuated fasteners at least 1 in. long.
- 23.2** Attach furring to open web steel joist by saddle tying.
- 23.3** Attach hat channel furring to cold-formed joists with two screws in each joist through channel flanges.
- 23.4** Attach furring to wood joists by saddle tying to: see detail "A", pg. 12.
- 23.4.2** a pair of 8d common nails (one on each side) driven diagonally downward to a penetration of at least 1 1/2 in., from a point at least 2 in. above the bottom of the joist.

24. SUSPENDED CEILINGS: MATERIALS

- 24.1** Metal lath shall be of the type and weight for the spacing of supports (cross-furring) as set forth in table 4, section 7.
- 24.2** Main runners shall be as specified in 6.7, of the size and spacing for the runner spans (distance between hangers) as set forth in table 8.

TABLE 8
MAXIMUM ALLOWABLE RUNNER SPANS
(Distance between hangers)
(Multi span conditions)

MAIN RUNNER TYPE	RUNNER SPACING				
	48 in.	42 in.	36 in.	30 in.	24 in.
1 1/2 in. CRC	3'3"	3'7"	4'2"	4'6"	4'10"
2 in. CRC	4'1"	4'3"	4'6"	4'10"	5'2"
2 1/2 in. CRC	4'3"	4'6"	4'9"	5'0"	5'5"

NOTES:

- Bare metal thickness shall be not less than 0.0538 in. 2. Steel shall be cold formed from steel with minimum 33,000psi yield strength. 3. Channel shall have a minimum G60 galvanized protective coating.
 - Channel minimum weights per 1000 linier feet: 1 1/2 in. 414 lbs.; 2 in. 506 lbs.; 2 1/2 in. 597 lbs.
- 24.3** Cross furring shall be as specified in 6.7, of the type and spacing for the furring spans (distance between runners as set forth in table 7 except that hat channel shall not be used for cross furring on suspended ceilings.)

- 24.4** Cross furring shall be saddle tied to main runners with not less than 0.054 in. (16 ga.) wire. Suitable clips or other accessories designed for this purpose if they are capable of providing equal strength.

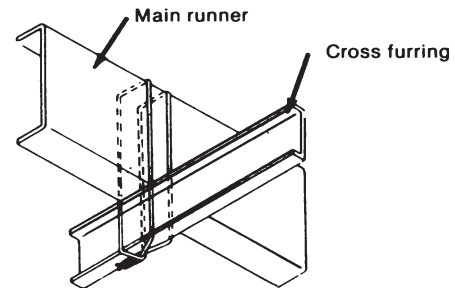

SADDLE TIE

- 24.5** Hangers shall be as specified in 6.8 and 6.9, of the type and size for the area of ceiling supported as set forth in table 9.

TABLE 9

TYPE HANGER	MAXIMUM AREA SUPPORTED (sq. ft.)
1 in. X 3/16 in. flat.	22
1 1/4 in. X 1/8 in. flat	22
6 gage wire	20
7 gage wire	16
8 gage wire	14
9 gage wire	12.5

25. SUSPENDED CEILINGS: INSTALLATION

- 25.1** Attach wire hanger to the construction above the desired ceiling. For each of the installations described below, execute the attachment in a manner, which will insure the development of the full hanger strength. Any wire hanger shall be terminated by three full turns around itself.
- 25.2** Attach wire hanger to concrete by:
- securing the wire hanger to the steel reinforcement, or
 - securing the wire hanger to special inserts, or
 - tying the wire hanger to a drop clip.
- 25.4** Attach wire hanger to wood by:
- inserting it through hole drilled 3 in. or more above the bottom of wood joist and twisting end three times around itself, or

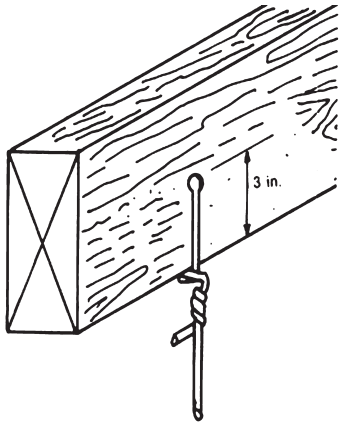

Hanger Attached to Support through a Drilled Hole

- 25.4.2 by tying top of hanger to a 30d common nail, driven to a penetration of 3 in. or more from a point 5 in. or more from the bottom of the joist, or
- 25.4.3 stapling top of hanger to joist with four 1 1/2 in., 0.148 in. (9 ga.) wire staples (three near upper end and a fourth to hold the main wire to the joist).

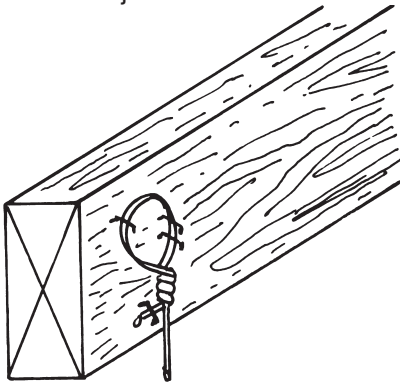

Hanger Attached to Support Using Staples

- 25.5 Attach wire hanger to the suspended member in a manner, which will restrain twisting and turning of the member and which will insure development of the full hanger strength.

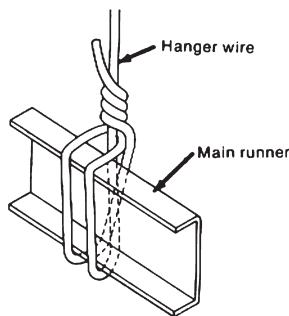

Saddle Tie

- 25.6 Attach straphanger to the construction above the desired ceiling. For each so the installations described below, execute the attachment in a manner that will insure the development of the full hanger strength.

- 25.7 Attach straphanger to concrete by:

- 25.7.1 bending the strap around the steel reinforcement, or

- 25.7.2 by 90° bending 3 1/2 in. of the end and embedding the bend 2 1/4 in. or more within the concrete, or

- 25.7.3 by bolting to special inserts.

- 25.8 Attach straphanger to steel by:

- 25.8.1 bolting it to the steel

- 25.8.2 by wrapping the hanger around or through the steel member and bolting or tying the end back to the strap, or

- 25.8.3 by bolting to special clips.

- 25.9 Attach strap hanger to wood by spiking through strap into joist with two 12d common nails clinched over the strap, or

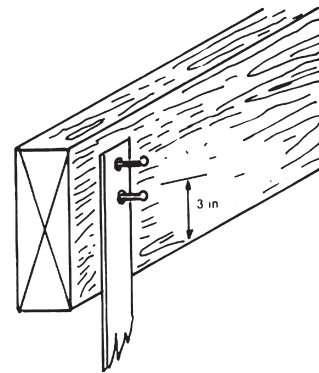

Flat Hanger Attached to Support Using Nails

- 25.10 by bolting through holes in the strap.

- 25.11 Attach straphanger to suspended member by bolting through holes prepunched or drilled in the strap 1/2 in. clear or more from the end.

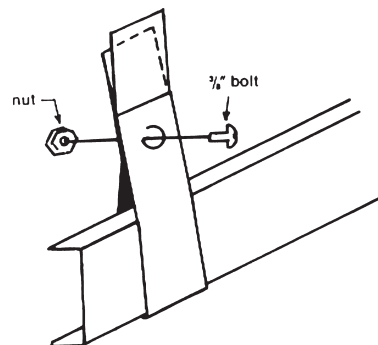

Flat Hanger Attached to Support with Stove Bolts

- 25.12 Bolts for the straphangers shall have at least 3/8 in. nominal diameter.
- 25.13 Located a hanger within 6 in. of ends of main runners.
- 25.14 Locate main runner within 6 in. of walls to support ends of cross furring. (see below)

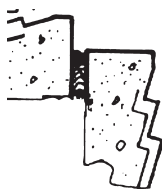
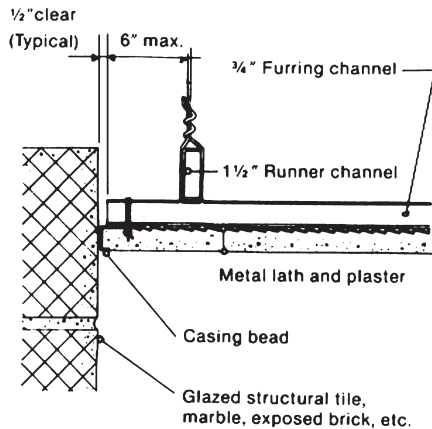

Cross Furring, Hanger Wire Locations and Proper Caulk Joint

- 25.15 Permit no part of the suspension grid (main runners and cross furring) to come into contact with abutting walls or load bearing partitions or penetrations such as columns.
- 25.16 Where main runners are suspended from joists, and where spacing permits, run main runners transverse (in the opposite direction) to joists.
- 25.17 When design dictates the construction of an unrestrained suspended ceiling, terminate periphery of ceiling with casing bead (plaster stop) allowing at least 3/8 in. clearance between casing bead and adjoining walls. After plastering, install backer rod and elastic caulk to fill this void if desired. This caulking material must not restrict movement in any direction. See detail above.
- 25.18 Uplift control can easily be handled by installing toe-to-toe cold rolled channels held together around an appropriate number of hanger wires, by tie wires. The channels should be 1" shorter than the hanger wires to allow some movement.

- 25.19 When splicing either runner or furring members they shall be lapped a minimum of 12 in. and wire tied at each end of the splice with two loops of 0.054 in. (16 ga.) wire. Do not screw-attach splices. When the splice occurs at a control joint the ties should be applied loose enough to allow some telescoping of the channels, but tight enough to hold them in place.

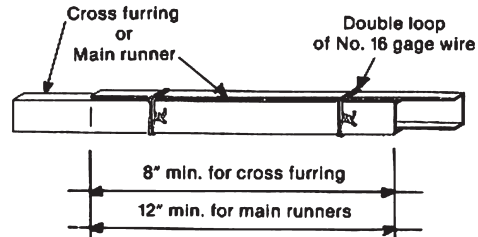

Channel Splice

26. BEAM BOXES: MATERIALS

Frequently it is desired to individually fire protect a beam, girder, or truss. This is especially true where the steel members support a reinforced concrete slab floor. An enclosing membrane of this nature can be constructed readily with metal lath and plaster. The weight saving thereby accomplished as compared to encasing the member with concrete is substantial, just as is the case with membrane-protected ceiling of metal lath and plaster. Weight reduction is logically followed by cost reduction.

- 26.1 Metal lath shall be of the type and weight for the spacing of supports as set forth in table 4, section 7.
- 26.2 Beam box brackets shall be formed from 3/4 in. cold-rolled channels.
 - 26.2.1 Where beam box brackets support lath directly, they shall be spaced in accordance with spacing of supports as set forth in table 4, sec. 7.
 - 26.2.2 Where beam box brackets support furring, they shall be spaced not to exceed 36 in. on center.
 - 26.2.3 Stiffeners for the corners of beam box brackets shall be 3/4 in. cold-formed channels.
- 26.3 Attachments shall be not less than the following:
 - 26.3.1 for tying brackets to structural members or ceiling grids, 0.068 in. wire (minimum) saddle tied.
 - 26.3.2 for tying furring to brackets, one loop of 0.054 in. (16 ga.) diameter wire or two loops of 0.043 in. diameter wire.

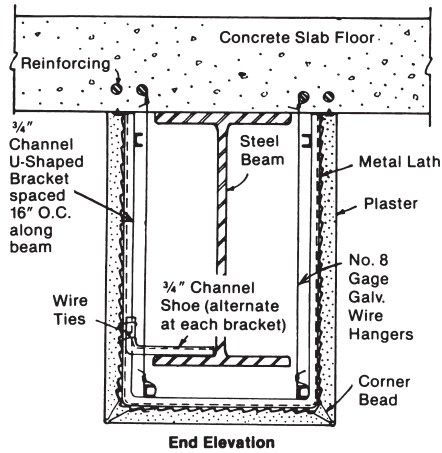

End Elevation
SUSPENDED FURRING

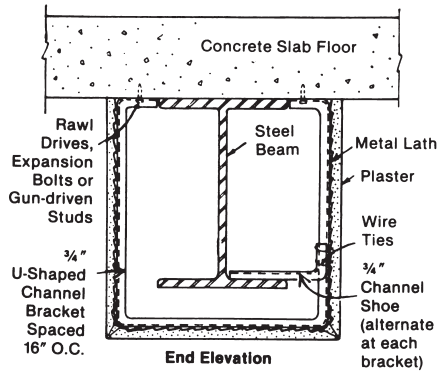

End Elevation
SUSPENDED FURRING

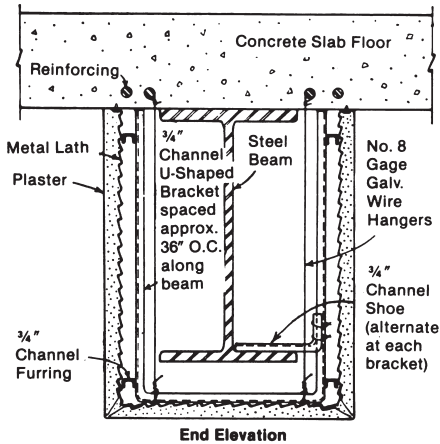

End Elevation
SUSPENDED FURRING

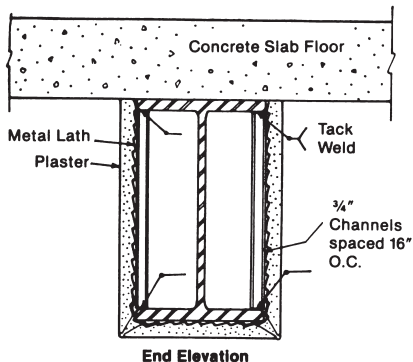

End Elevation
CONTACT FURRING

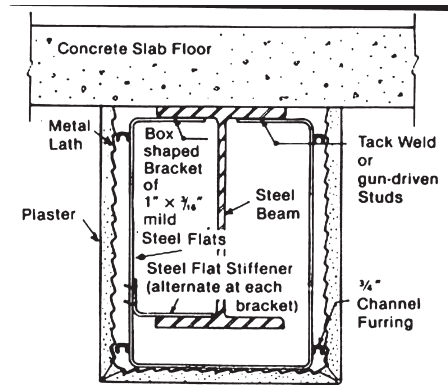

End Elevation
COMBINATION FURRING AND SUSPENSION

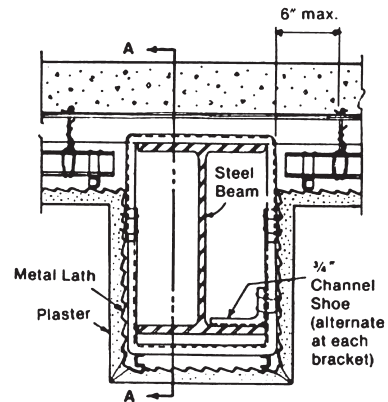

End Elevation

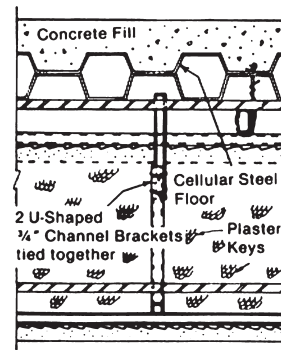

Section A-A

ALTERNATE FOR BEAMS SUPPORTING CELLULAR STEEL FLOORS

26.3.3 for tying stiffeners to brackets, one loop of 0.043 in. (18 ga.) diameter wire.

26.3.4 for tying lath to supports, one loop of 0.043 in. diameter wire.

26.4 Supplementary hangers for supporting ends of ceiling grids (main runners and cross furring), which in turn support beam box brackets, shall be of the appropriate size for the total plaster area of the beam box and any other contributory area. Sizes shall be as specified in section 24.5.

27. BEAM BOXES: INSTALLATION

- 27.1 Install supplementary hangers on ceiling runner channels within 6 in. of where the beam box bracket is to be attached to the ceiling grillage. Additional hanger wires will likely be required from the main support members to carry the added load of the beam boxes.
- 27.2 Attach hanger to the member supporting the beam box bracket in the same manner as the hangers on the rest of the ceiling grid are attached.
- 27.3 Attach beam box bracket to main ceiling runner with wire ties, bolts, or clips or
- 27.4 to the underside of concrete slabs with powder or power driven fasteners, supplemented with channel kickers to alternate sides of steel beams, or
- 27.5 with channel kickers wedged against steel beams in a manner so as to develop the full strength of the assembly. See illustrations.

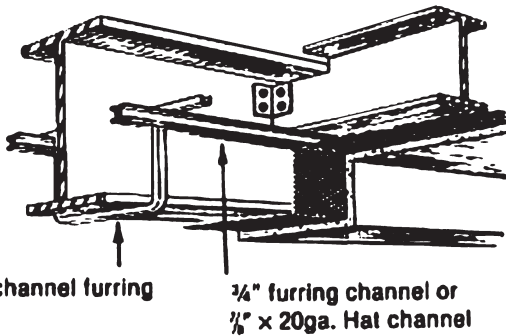

Furred Beam in a Contact or Furred Ceiling

28. COLUMN FURRING: MATERIALS

- 28.1 Metal lath shall be 3.4 lb./sq. yd. Diamond mesh for columns made of rolled structural steel shapes or 3/8 in. rib metal lath for round steel columns.
- 28.2 Diamond mesh metal lath shall be self-furring or shall be furred with 3/4 in. cold rolled channels.

29. COLUMN FURRING: INSTALLATION

- 29.1 For columns made from rolled structural steel shapes,
- 29.1.1 Erect self-furring metal lath so that it neatly fits the column and wire tie at laps, 6 in. o.c., or
- 29.1.2 Install cold-rolled channels as furring brackets around column, and attach metal lath to furring brackets and wire tie laps at 6 in. o.c., or

- 29.1.3 Install vertical furring in accordance with sections 12 and 13 and attach metal lath to furring.

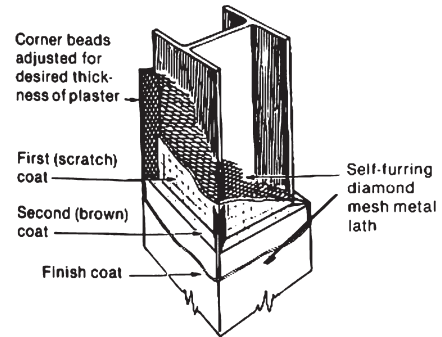

Self-Furring Metal Lath

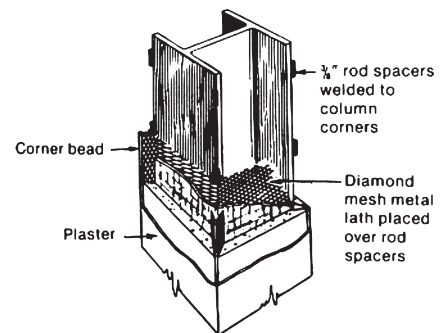

Welded Spacers

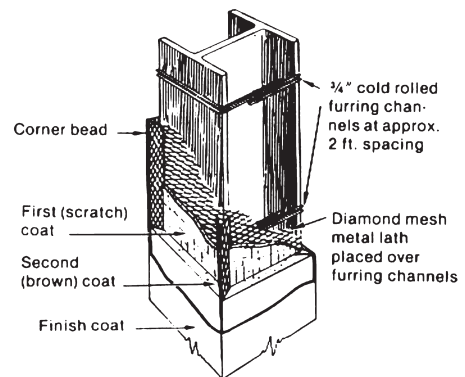

Channel Furring

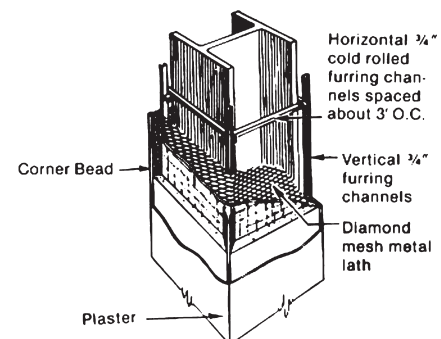

Channel Furring

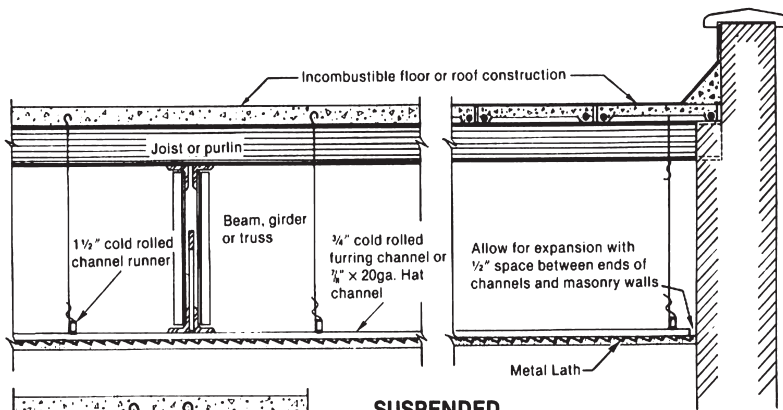

SUSPENDED MEMBRANE FIREPROOFING

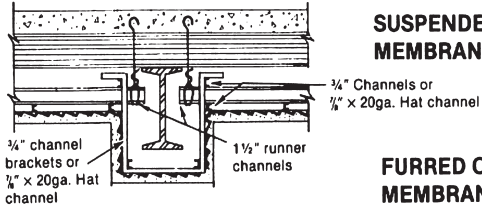

FURRED OR CONTACT MEMBRANE FIREPROOFING

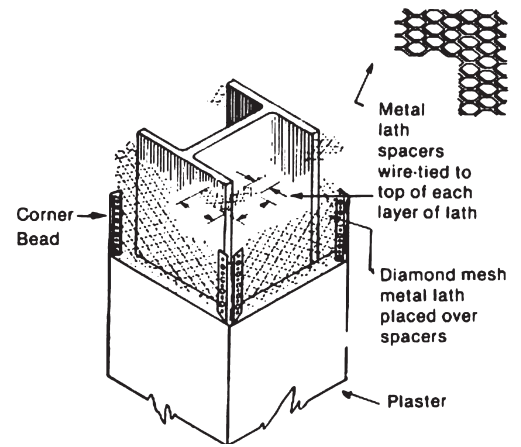
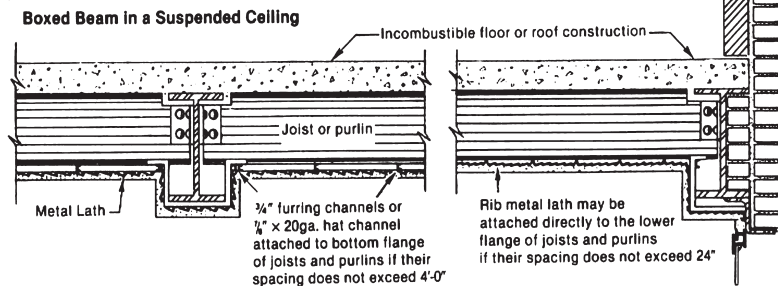

Metal Lath Spacers W-Column

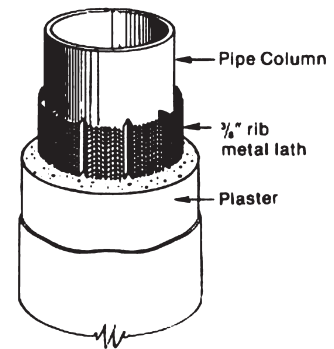

Rib Lath on Pipe Column

29.2 For columns made of steel pipes, erect 3/8 in. rib metal lath with long dimension of sheet (ribs) vertical.

29.2.1 Bend lath around column, with closed portion of rib against the column.

29.2.2 Attach lath to column with loops of 0.043 in. (18 ga.) wire around the column at 16 in. o.c.

30. METAL LATH REINFORCEMENT FOR PLASTER BASES OTHER THAN METAL LATH: MATERIALS

30.1 Corners –

30.1.1 The plaster at all internal vertical or horizontal corners shall be reinforced with not less than 2 in. x 2 in. cornerite.

30.1.2 The plaster at all external corners shall be reinforced with galvanized, expanded wing corner bead.

30.2 Lath joints – The plaster over all gypsum lath joints that extend parallel with the supports

for more than 16 in. shall be reinforced with strip lath not less than 4 in. wide.

30.3 Openings – The plaster over all chases or similar openings of more than two square feet shall be reinforced with strips of metal lath not less than 6 in. x 12 in., placed diagonally at the corners of the openings.

30.4 Chases – The plaster over all chases or similar openings, shall be reinforced by covering the opening with metal lath.

30.5 Solid Surfaces – The plaster over all solid surfaces that do not provide adequate mechanical or chemical bond (i.e., portland cement over gypsum or any plaster over painted surfaces) shall be reinforced by covering the surface with self-furring metal lath.

30.6 Door Frames – The plaster at door frames that are continuous from floor to ceiling in masonry partitions shall be reinforced by covering the frame from the top of the opening to the ceiling with a strip of metal lath at least 12 in. wide.

31. METAL LATH REINFORCEMENT FOR PLASTER BASES OTHER THAN METAL LATH: INSTALLATION

31.1 Where metal lath is applied over another plaster base (reinforcement of opening corners, over door frames, etc.,) attach metal lath lightly to base material.

31.2 Where metal lath is applied over open spaces (chases, etc.) firmly attach metal lath along each edge support with a fastener suitable to the support and with fastener spacing not to exceed 7 in. o.c.

DESIGN ASSUMPTIONS AND REFERENCES

1. Fire resistance ratings are given to assemblies by building codes and are based on fire endurance tests. A listing of test results for metal lath and plaster assemblies are available from Underwriters Laboratories® and The Association of the Wall and Ceiling Industries International. Other organizations and manufacturers may offer additional information on fire ratings and testing.
2. Selection of metal lath is usually determined by the assembly orientation (vertical or horizontal), support spacings, and bearing surface of the supports. A guide to selection is shown in table 3 and Table 4, Section 7. If lath is used, other than that produced by members of the ML/SFA, calculations should be made independently of tables and charts given in this publication.
3. Tolerances for lath products are established on weight basis in ASTM C847 (+/- 10%)
4. The physical properties of channels produced by members of the EMLA are given in Table 1, Section 6.7.
5. Recommended wire hanger gages are shown in paragraph 24.5. these recommendations are based on a ceiling load of 10 lbs. per square foot, and the ultimate strength of the wire hanger and the grillage members. For loadings exceeding these recommendations, attention should be given to local failure of the grillage member. Vibrational loads have not been considered, and if they are anticipated, appropriate design modifications are required.
6. Gypsum plaster load is assumed to be 10 pounds per square foot dry and 12 pounds per square foot wet. Three coat portland cement stucco is assumed to be 12 pounds dry and 14 pounds wet and its use requires appropriate design modifications.
7. Deflection of a plastered assembly is limited to one three hundred sixtieth of the span ($L/360$). Lath spans (spacing of supports) are also limited to prevent a panel from losing its wet plaster when the plasterer trowels the adjacent panel.
8. Plaster systems should be designed to be structurally independent of the main supporting structure. Whenever possible, prevent structural loads from being transferred to the plastered assembly through the use of plaster trims, expansion joints, cushion or slip joints and the like.
9. Corrosion is not a normal design concern when the proper accessory material for the conditions is specified. However, where severe exposure conditions exist, undesirable galvanic corrosion may take place. These special conditions require special design considerations. (See paragraph 6.5). Many lath manufacturers recommend zinc alloy accessories for all exterior applications.
- 9.1 Where concrete or masonry substrate surface is:
 - a. relatively plumb,
 - b. free of gross surface irregularities,
 - c. not subject to structural loading,
 - d. not subject to drastic temperature changes, but has been coated previously, or for any reason the surface does not provide a surface that is capable of establishing a mechanical bond with the plaster or stucco, then the area should be covered with self-furring metal lath secured with a combination of masonry stub nails, and power or powder actuated fasteners as prescribed in ASTM C1063, or solely with power or powder actuated fasteners. These shall be applied at the required intervals and portland cement plaster may be applied in the usual prescribed manner.
- 9.2 The spacing of fasteners should approximate that of wood framing; namely vertical rows of fasteners, with rows spaced a minimum dis-

tance of 16 in. o.c. with fasteners spaced not to exceed 7 in. o.c. vertically. At least six fasteners per sheet must be power or powder actuated fasteners in order to meet ASTM requirements. These fasteners are to be located at each corner and half way down the long edge of each sheet. The balance of the field of the sheet may be fastened with concrete stub nails that are at least 3/4 in. in length and with a head at least 1/2 in. in diameter (ASTM C1063 allows 3/8 diameter heads) washers can be used to enlarge the head of typical stub nails. All fasteners shall have a minimum “pull out” resistance of 50 lb. per fastener, unless specific design requirements indicate greater strengths. Fasteners should be applied at the locations of the self-furring mechanisms in a fashion that does not negate the intended effect of these mechanisms when fasteners are driven home.

9.3 Where conditions “a” and “b” exist, but “c” and “d” do not, paragraph 9.2 still applies, except that a paper-backed metal lath should be used or a water resistant membrane should be interposed between the metal lath and the masonry base to tend to isolate the plaster (stucco) and lath membrane from the stress concentrating effects of such conditions.

9.4 If none of the above conditions (a,b,c,d) exist then the metal lath and plaster membrane should be furred from the surface of the concrete or masonry wall. See Sections 12 through 15.

9.5 If all the above conditions (a,b,c,d) exist, and the surface is uncoated and relatively porous, providing an interface boundary that is capable of establishing a mechanical bond, then portland cement plaster (stucco) may be applied directly to vertical masonry or concrete surfaces after usual surface preparation for such application. This may involve surface roughening or the application of a bonding or dash coat. Consult coating manufacturers for direction.

ADDITIONAL REFERENCES

The specifications and standards to which this specification makes reference in various sections have been listed under “Section 2, Referenced Documents”. Additional references, which the designer may use for related information are:

ASTM Standards

C645 Standard Specification for Nonstructural Steel Framing Members.

C841 Installation of Interior Lathing and Furring.

Federal Specifications

FF-P-395 Pin, Drive, Guided and Pin Drive, Power Actuated (Fasteners for Power Actuated and Hand Actuated Fastening Tools)

FF-P-395 Shield, Expansion: Nail, Expansion: and Nail, Drive Screw (Devices Anchoring Masonry)

Underwriters Laboratories

Fire Resistance Directory

Minnesota Lath & Plaster Bureau “Lath Inspection Resource Manual”

Stucco Resource Guide Northwest Wall and Ceiling Bureau

APPENDIX A

TIES AND SPLICES

Several types of ties are used in the installation of metal supports and metal lath:

DOUBLE-WRAP TIE – Used in tying spliced metal members such as channels or studs, the double-wrap tie is formed by two complete wraps of a single strand of wire around the spliced members at each end of the splice. The tie is completed with a stub tie.

SADDLE TIE (A) – Used in tying a hanger wire to main runner channels to support a suspended ceiling, the tie is completed by twisting the hanger wire three times around its self. The saddle tie prevents rotation of the channel, and as the tie tightens it hold on the channel firmly.

SADDLE TIE (B) – Generally used in tying cross furring channels to the underside of main runner channels, and horizontal stiffeners in partitions and vertical furring, this type of saddle tie is used to prevent rotation of the furring channel or stiffener. The tie is completed with a stub tie.

FIGURE EIGHT TIE – Used in attaching channel runners to channel brackets. Tie is made at intersection of runner and internal angle of each bracket it crosses to secure the runner to both vertical and horizontal legs of bracket. The tie is completed with a stub tie.

STUB TIE – This is the industry name given to the process of completing any light gage wire tie with (minimum) 1 1/2 to 2 twist of the two ends of the tie wire forming wings 1/2 to 3/4 in. long, parallel to the direction of the tie, and in opposite directions to each other. The stub tie is used most often in the attachment of metal lath to cold rolled channel where wire tying is required. See detail B.

Butterfly Tie – Used almost exclusively in attaching metal lath to metal supports such as channel, this is accomplished by a full twist of the ends of the wire forming wings 1/2 to 3/4 in. long, parallel to the direction of the tie, and in opposite directions to each other. Wings must lay up tight against the lath.

Note: Where a single strand of No. 16 gage wire is used to form a tie, double strands of No. 18 gage wire may be substituted, achieving equivalent or greater load capacity.

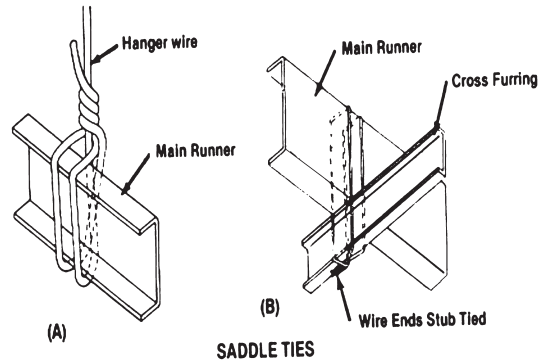

SAFE LOADS FOR SINGLE STRANDS OF THE TIE WIRE ¹		
Wire Gage	Safe Load In Lbs. ²	Estimated Ultimate Strength in Lbs. ³
18	32	108
16	56	136

1. A single strand of wire may be a hanger in a suspended ceiling where only one strand supports the load. When a single loop of tie wire is made, two strands of wire support the load. Example: Each 18 gage wire attaching metal lath to a channel will support a total load of 2 x 32 or 64 pounds safe load.
2. Based on a design or working stress of 18,000 psi.
3. Based on ultimate tensile strength of 60,000 psi.

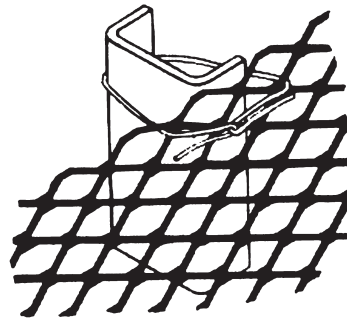

BUTTERFLY TIE

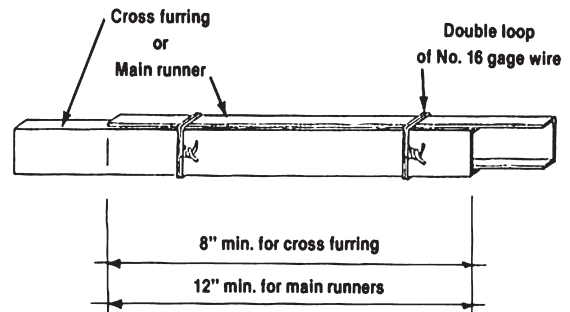

CHANNEL SPLICE

LATHING AND FURRING CONNECTIONS

The connection of lathing and furring steel framing members is most often accomplished by utilizing one of two methods: screwing with self-drilling or self-tapping screws or wire tying. Structurally adequate, uncomplicated and economical connections are possible using each fastening method. Each has advantages suited for particular applications. Screw connections are somewhat rigid while wire tying is the least rigid and is desirable for applications such as suspended ceilings.

SCREW ATTACHMENT

Self-drilling, self-taping screws are also used to attach metal lath and for the connection of steel framing members. This type of screw drills its own hole through the two pieces to be joined, then taps a thread in both pieces in fastening them together.

In addition to connecting two framing members, this type of screw is also used for connection of metal lath or other wall facing materials, electrical components, clips, and accessories.

A hand-held variable speed screw gun or cordless drill with screw bits, that operates at approximately 2,500 are commonly used to drive these screws. The screws are available in a variety of head styles to fit particular requirements. A 7/16 in. wafer head screw is the most common and recommended screw head for metal lath applications, while pan head or hex head screws are common for framing connections.

DESIGN OF SCREW CONNECTIONS

Screw connections should be designed to transmit the maximum stress in the connected member with proper regard for eccentricity. Suggested design shear and pullout loads for common size screws are listed in the table below.

SUGGESTED CAPACITY FOR SCREW CONNECTORS (POUNDS)

Steel Thickness Gage (33 KSI min. Yield)	No.10-16 D= .138" T= .153"		No. 8-18 D= .120" T= .125"		No. 6 D= .100" T= .106"	
	Shear or Bearing	Pull-out	Shear or Bearing	Pull-out	Shear or Bearing	Pull-out
18	263	98	248	94	188	83
20	141	69	140	68	133	53

NOTES:

1. "D" = Root Diameter; "T" = Drill Point Diameter
2. Screw capacities are based on the connected material minimum yield strength of $F_y = 33,000$ PSI. The ratio of the material ultimate tensile strength to yield strength should be equal to or greater than 1.15.
3. Screw spacing and edge distance shall not be less than $1.5 \times D$ or $P/0.6 F_{yt}$, where D is the screw shank diameter, P is the shear load and t is the steel thickness.
4. For steels having yields other than 33 KSI, use the following formula only:

$$\frac{\text{Table Value} \times \text{Actual KSI}}{33 \text{ KSI}} = \text{New Value}$$

Attaches fiber sheathing, rigid insulation, etc. Has 7/16" dia. flared head and #8 shank. Length 1 1/4". Parkerized finish.



Attaches metal lath and accessories, metal panels, etc. The 7/16" dia. pan washer head spans lath openings. Has #8 shank. Length 1/2". Parkerized finish.



For self-furring metal lath attachment through sheathing. Has 7/16" dia. flat wafer head and #8 shank. Lengths: 1/2" and 1 1/4". Parkerized finish.



Used for steel to steel connections. Has 3/8" dia. indented hex washer head and #10 shank. Length 3/4". Zinc or cadmium plated.



FASTENER TYPES

ANCHOR FASTENING

Power actuated fasteners and expansion masonry anchors are commonly used for attaching cold-formed framing to concrete and in the case of power actuated fasteners, used to attach metal lath to concrete or block.

POWER ACTUATED FASTENERS

Suggested design loads for power driven fasteners are shown in the following tables. The fasteners used in power-actuated tools are manufactured from special steel, heat-treated to produce a very hard yet ductile fastener. The two basic types available are drive pins and threaded studs, although drive pins are used almost exclusively in cold-formed steel frame construction.

SUGGESTED CAPACITY FOR POWER DRIVEN FASTENERS IN CONCRETE (POUNDS)

SHANK DIAMETER	MINIMUM PENETRATION	TYPE OF LOADING	CONCRETE COMPARISON STRENGTH (PSI)		
			2000	3000	4000
0.145 IN.	1 1/8 IN.	PULLOUT SHEAR	90 160	115 225	145 265
0.177 IN.	1 7/16 IN.	PULLOUT SHEAR	150 250	205 285	275 330
0.205 IN.	1 1/4 IN.	PULLOUT SHEAR	220 390	280 445	345 500

NOTES:

1. Capacities shown are for stone aggregate concrete and are based on low velocity shot.
2. Minimum fastener spacing: 4"; minimum fastener edge distance: 3".
3. Values may not be increased by 1/3 for wind or seismic loads.
4. ICBO uninspected values – Hilti/ICBO research #2388.

SUGGESTED BEARING CAPACITY FOR POWER DRIVEN FASTENERS USED TO CONNECT GAGE THICKNESS STEEL (POUNDS)

FASTENER SHANK DIAMETER	STEEL GAGE THICKNESS	
	18 GAGE	20 GAGE
0.145"	210	197
0.177"	321	241
0.205"	372	279

NOTES: 1. Bearing Capacity based on Bearing Area x 1.15 x 33,000 PSI.

SUGGESTED CAPACITY FOR POWER DRIVEN FASTENERS IN STRUCTURAL STEEL (POUNDS)

STEEL THICKNESS GAGE	Shank Dia.: 0.145"			Shank Dia.: 0.177"			Shank Dia.: 0.205"		
	Steel Thickness			Steel Thickness			Steel Thickness		
	1/4"	3/8"	1/2"	1/4"	3/8"	1/2"	1/4"	3/8"	1/2"
18	210	210	210	321	321	321	372	372	372
20	197	197	197	241	241	241	279	279	279

NOTES:

1. Tests were conducted with the fastener point driven completely through the backside of the hot-rolled steel member.
2. Fasteners should not be located less than 1/2" from the edge of the steel.
3. A minimum fastener spacing of 1 1/2" is necessary.
4. Bearing strength based upon: bearing area x 1.15 x 33,000 psi for cold-formed steel.
5. Capacities shown are for either shear or pullout.
6. Values may not be increased by 1/3 for wind or seismic loads.
7. ICBO uninspected values – Hilti/ICBO research #2388.

The fasteners are normally driven by cased power loads are normally driven by power loads, available in sizes ranging from .22 through .38 caliber, and in various power levels for each size, primarily used to attach framing or furring to concrete or block bases. Metal lath is primarily attached with compressed air or gas operated shot pin (and washers) guns. The selection of powder shot or power shot loads is based on the base material into which the fastener is being driven.

When a fastener is driven into concrete base material, the holding power results primarily from compression bond of the concrete to the fastener shank. The fastener, on penetration, displaces the concrete, which tries to return to its original form and exert a squeezing effect.

Compression of concrete around the fastener shank takes place with the amount of compression increasing in relation to the depth of penetration and the compressive strength of the concrete.

EXPANSION ANCHORS

Expansion anchors in concrete develop holding strength primarily from a compression bond of the concrete to the anchor shank. A hole, the same size as the anchor, is drilled in concrete. The anchor is installed in the hole, and expanded by turning the

nut on the shank. A sleeve on the shank expands to provide the compression bond.

The amount of compression increases with increased concrete compressive strength and increased anchor diameter, provided there is adequate embedment depth.

Expansion anchors are used in conjunction with hot-rolled steel plate, angles or channel to supplement bearing capacity of metal lath support framing.

Suggested design shear and pullout loads for various size anchors are listed in the table below.

OTHER FASTENING SYSTEMS

BOLTS. Cold-formed supports and furring are not pre-punched with fasteners holes, threaded or unthreaded. As a result, nuts and bolts generally are not used with this system. The major exception would be anchor bolts.

WIRE TIES. Wire tying is quite acceptable for attaching metal lath to framing components, or for attaching accessories to lath where a pliant connection moderates the effects of stress concentrations, but should never be used for joining framing components in load-bearing or curtainwall applications.

SUGGESTED CAPACITY FOR EXPANSION ANCHORS IN STONE AGGREGATE CONCRETE (POUNDS)

ANCHOR DIAMETER	MINIMUM EMBEDMENT	TYPE OF LOADING	CONCRETE STRENGTH (PSI)			MINIMUM ANCHOR SPACING	MINIMUM EDGE DISTANCE
			2000	4000	6000		
1/4 in.	2 1/2 in.	Pullout Shear	325 380	420 650	420 650	2 1/2 in.	1 1/4 in.
1/2 in.	3 3/4 in.	Pullout Shear	665 1710	900 2080	1210 2320	3 in.	2 1/2 in.
3/4 in.	3 1/4 in.	Pullout Shear	935 3050	1270 4270	1360 4510	7 1/2 in.	3 3/4 in.
1 in.	4 1/2 in.	Pullout Shear	1610 6280	2000 6720	2530 7960	10 in.	5 in.

NOTES:

1. Pullout values listed may be doubled with special inspection.
2. Values may not be increased by 1/3 for wind or seismic loads.
3. ICBO uninspected values – HILTI/ICBO report #2156

PENETRATION FLASHING RECOMMENDATIONS

FOR PORTLAND CEMENT PLASTER WALL AND PENETRATING FIXTURES

Section 1707(b) of the Uniform Building Code states "Exterior openings exposed to the weather shall be flashed in such a manner as to make waterproof." The following procedure is recommended to achieve this intent in the flashing of penetrations to include, but not limited to, windows, doors, vents, etc. While flashing is rarely the responsibility of the lather or plasterer, it can greatly effect the outcome and performance of the stucco system.

Penetration Flashing Material

Material for flashing shall be barrier coated reinforced flashing material and shall provide for (48) hour minimum protection from water penetration when tested in accordance with ASTM D-779. Flashing material shall carry continuous identification.

Application

To flash penetrations, a strip of approved flashing material at least nine to twelve inches wide must be applied in weatherboard fashion around all openings. Apply the first strip horizontally immediately underneath the sill, cut it sufficiently long to extend past each side of the vertical flashing to be applied next. (Detail #1) Fasten the top edge of the first segment to the wall, but do not secure the body and lower edge of the first horizontal strip, so the weather resistant building paper applied later may be slipped up and underneath the bottom of the plate line to the bottom of the window sill when the window is flashed.

Next, apply the two vertical side sections of the flashing (jamb flashing). Cut the side sections sufficiently long to extend the width of the flashing above the top of the window and the same distance below the window. Apply the side sections over the bottom strip of flashing. (Detail #2)

The penetrating fixture then is installed by pressing the nailing flange positively into a continuous bead of sealant that extends around the bottom and vertical perimeter of the inserted fixture (such as windows).

NOTE: the continuous bead of sealant that is applied to the underneath side of the nailing flange of windows, doors, and vents is not to be construed as a substitute for flashing.

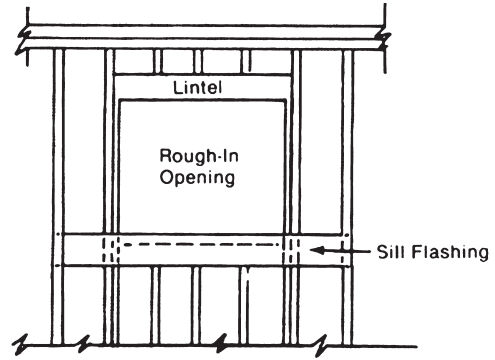

DETAIL #1

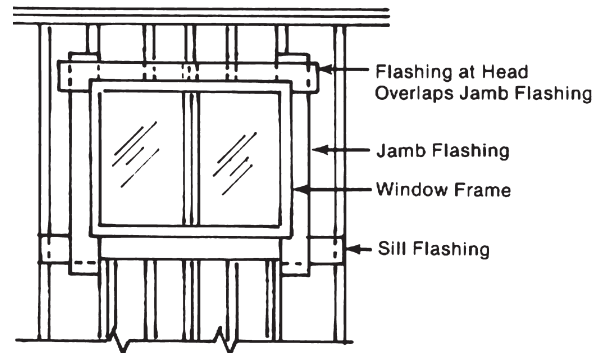

DETAIL #2

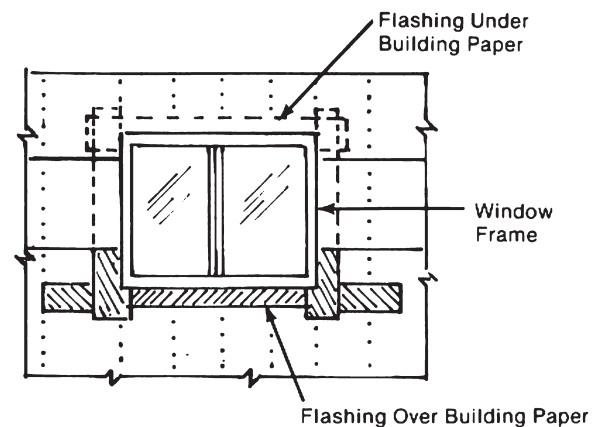

DETAIL #3

Apply the top horizontal section of flashing last (window head flashing), overlapping and sealed against the full height of the outer face of the top nailing flange with a continuous bead of sealant. Cut the top piece of flashing sufficiently long so that it will extend to the outer edge of both vertical strips of side flashing. (Detail #3)

Install exterior plaster weather resistant paper underlayment to complete an acceptable penetration flashing.

Commence at the bottom of the wall and overlapping the foundation weep screed top flange lay the approved weather resistant paper up the wall, (usually grade "D" building paper) overlapping a minimum of 2 in. in weatherboard fashion. Be sure that "A" is placed under the sill strip flashing. (Detail #4)

NOTE: *These recommendations are based on extensive experience and are not in any way intended to imply guarantees or warranties.*

These similar details can also be found in AAMA 2400-02 in greater detail.

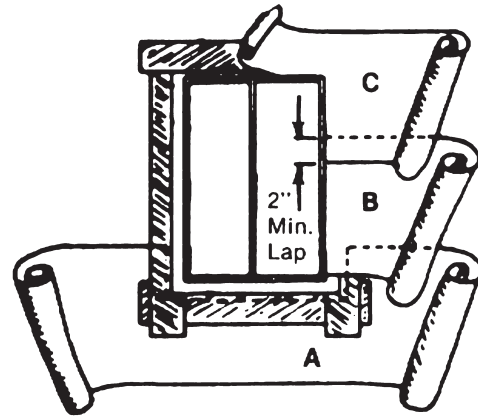

DETAIL #4

CONTROL JOINTS IN EXTERIOR PORTLAND CEMENT PLASTER

DISCUSSION

The construction of a building entails the utilization and assembly of numerous components and materials. This procedure of product co-mingling must consider and address the expansion-coefficients of these various materials in relationship to components to which they are attached or joined.

Control joints are necessary to aid in the control of stress and ultimately cracking that might be caused by stucco shrinkage during the curing process (hydration), minor movement due to framing or thermal movement. Two-piece expansion joints should be used where larger than normal amounts of expansion may occur.

To reduce the deformity or fracturing of materials, when stress from adjoining stronger components is impinged upon them, a relief separation (cased edges) or two piece joints or control joint is usually built in at calculated or predicted stress lines or levels even if these must be located closer than the normal prescribed locations for these elements. The designer must choose between one and two-piece joints as conditions dictate.

The details and explanations, which follow are typical portland cement plaster control joint installations. *There is never a guarantee that portland cement plaster (stucco) won't crack, but if the following described precautions are utilized, the response of the plaster membrane will more likely be absorbed at control joints and not in the cementitious membrane itself when any of the various possible pressures are exerted.*

PLACEMENT

Recommended spacing of control joints on typical construction is 144 square feet for walls or vertical applications and 100 square feet for ceilings or horizontal applications for Portland cement applications. These panels should be as square as possible. Length of panels shall not exceed 2 1/2 times their width. Provide perimeter relief where the plaster membrane abuts other materials utilizing casing beads as plaster stops.

The architect or designer must choose locations of the control and expansion joints on the structure by showing them on the elevations and in details, etc. Locate them at points of weakened structural planes as nearly as possible such as:

- Off of door, window and light troffer edges or corners
- At points of maximum spacing

Two-piece expansion joints should be placed at:

- Where main structural beams and columns join with walls and ceilings
- Over structure control joints
- Over junctures of dissimilar materials
- Floor lines at anticipated movement

CONFIGURATIONS

There are several styles of control joints manufactured for use in portland cement plaster membranes of which widths and grounds vary. Others could be available.

MATERIALS

Control joints are manufactured in galvanized steel (zinc coated steel) and zinc alloy (nearly pure zinc).

Galvanized Steel is used extensively in the industry since it is more rigid and tends to adhere to straightness more readily when being installed. Galvanized steel, as a general rule should not be used where frequent moisture exposure is expected, nor in low-pitched surfaces where slow drainage would occur. It should not be used near ocean coastlines where moist salt air lays, nor in areas where industrial corrosive chemicals could be expected. It performs best in lower moisture areas (arid) where rust and corrosion are least probable. Many lath manufacturers and industry experts recommend the use of only zinc alloy for all exterior applications.

Zinc Alloy is made from almost pure zinc with only enough alloy to aid in durability and formability. It can be used in almost any weather condition without expectation of rust or corrosion. Since it is a less rigid material, more care is needed during installation to assure straightness.

UNRESTRAINED CONSTRUCTION

The extent of the unrestrained condition between panels separated by control joints will often determine their degree of efficiency.

Total separation of the structure where control joints are to be placed is not always practical or possible. The architect may, however, in many circumstances, specify framing and control joint details where control joints are to be placed, which will call for:

- Double studs or separated suspended grillage
- Slip joints in framing connections
- Lathing metal reinforcement must be discontinuous through the control joint, yet allowing the weather resistant barrier (paper backing) to remain continuous, and wire tied to the lath on both sides of the joint

WEATHER RESISTANCE AND LATHING

The placement of control joints on a structure requires special care and precautions for lathing and weatherproofing at these points. Exterior lath consists of metal reinforcement and weather-resistant paperbacking. The weather-resistant paperbacking should continue through the joint unbroken and an extra piece of paperbacking should be installed under the joint to provide redundant weather-resistance. This should be installed weathereboard fashion to insure water resistance.

All intersections and terminations of control joints must be embedded and weather sealed in a bed of caulking material.

GENERAL

Many architects and designers find that control joints not only serve to isolate stress response, but also can enhance the beauty of the project.

Control joints can be utilized to break up larger expanses into interesting patterns and color schemes. Quality of work is easier to control when the natural screeds of control joints provide more guides and terminations for the mechanic to follow and use.

During the plastering process, the mechanic should remember that the control joint is to serve in both a decorative and functional manor; so care should be taken to avoid scraping or denting and to leave the joint clean when work is complete. All joints must be thoroughly cleaned of stucco and finish material in order for the joint to perform properly. **The vertical joints must be continuous through intersections while horizontal joints should be broken.**

The information and descriptions above are in no way meant to provide guarantees or warranties of any kind. This document was assembled to reflect the extensive experience and knowledge of many who are associated with the Lathing and Plastering Industry.

The Following Pages are "SUGGESTED DETAILS"

CONTROL JOINT ATTACHMENT FOR SUSPENDED CEILINGS

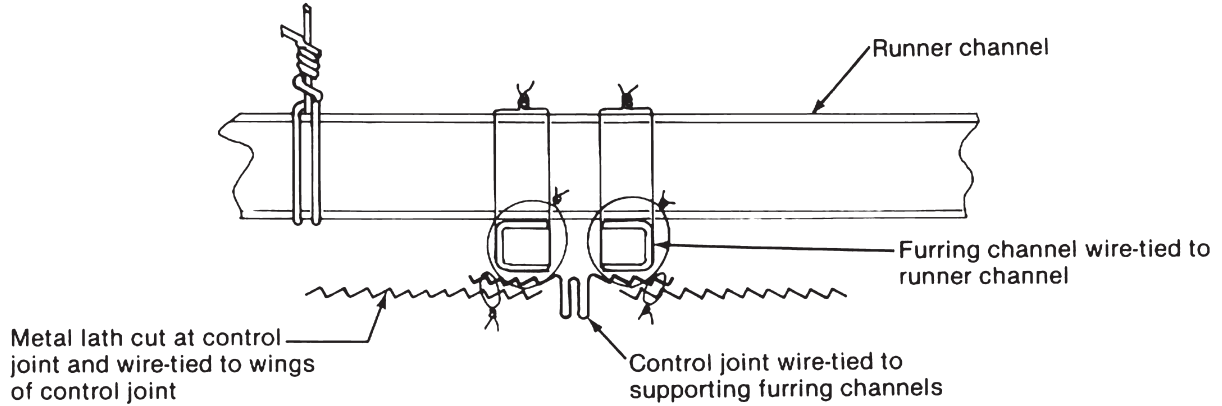

CONTROL JOINT PARALLEL TO FURRING CHANNEL

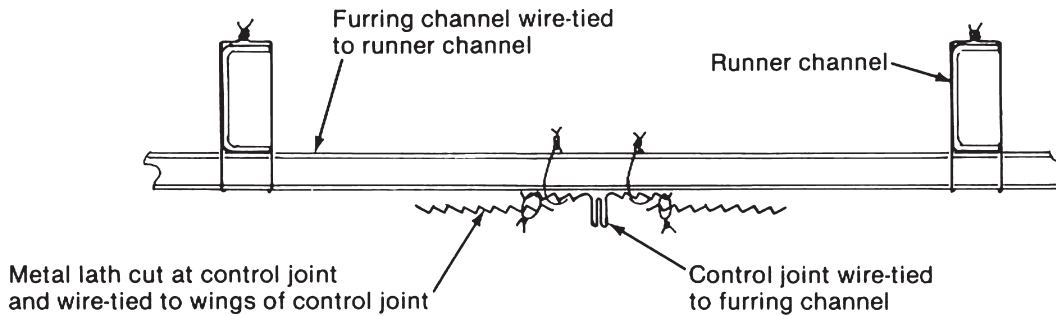

CONTROL JOINT RUNNING PERPENDICULAR TO FURRING CHANNEL WITH CEILING PERIMETER RELIEF

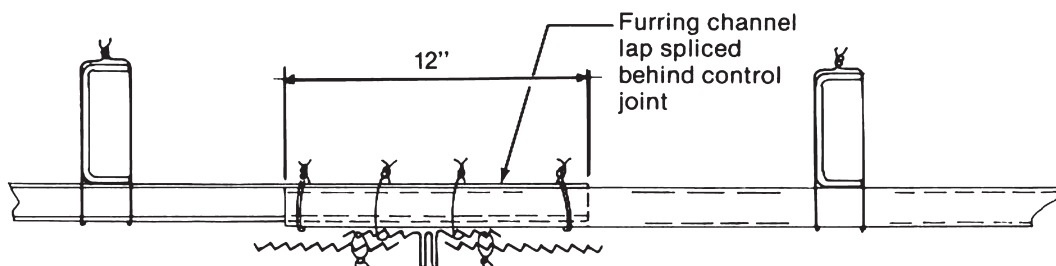

CONTROL JOINT PERPENDICULAR TO FURRING CHANNEL WITH (NO) CEILING PERIMETER RELIEF

APPENDIX B - Design Considerations

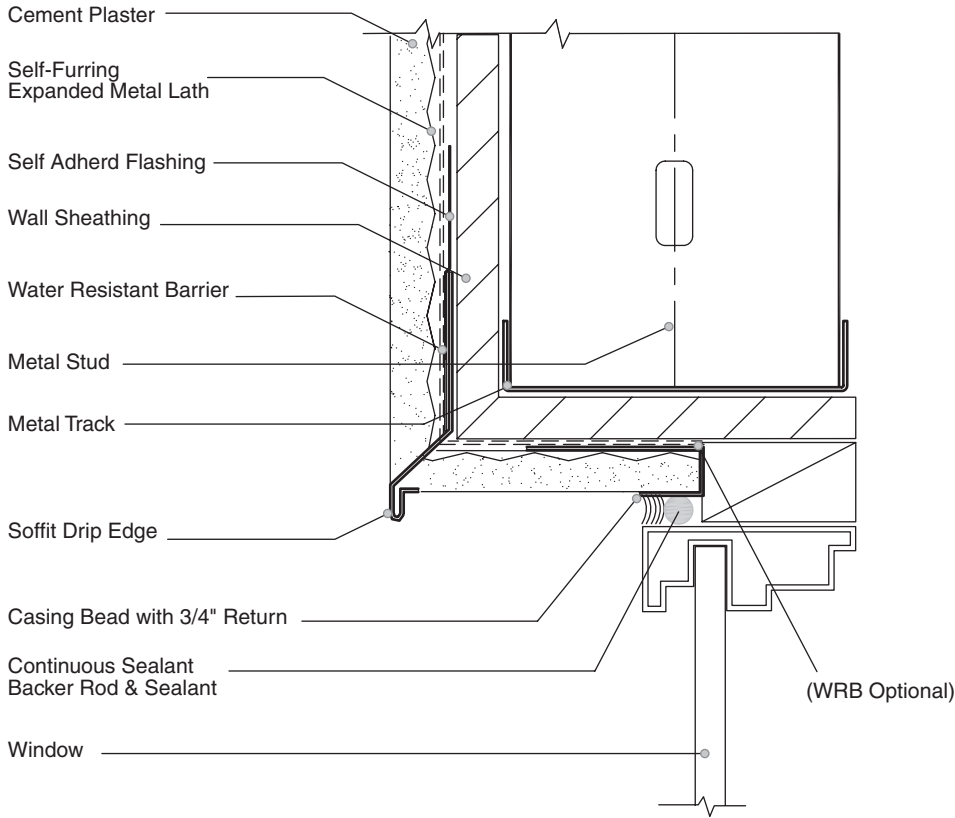

SOFFIT CORNER

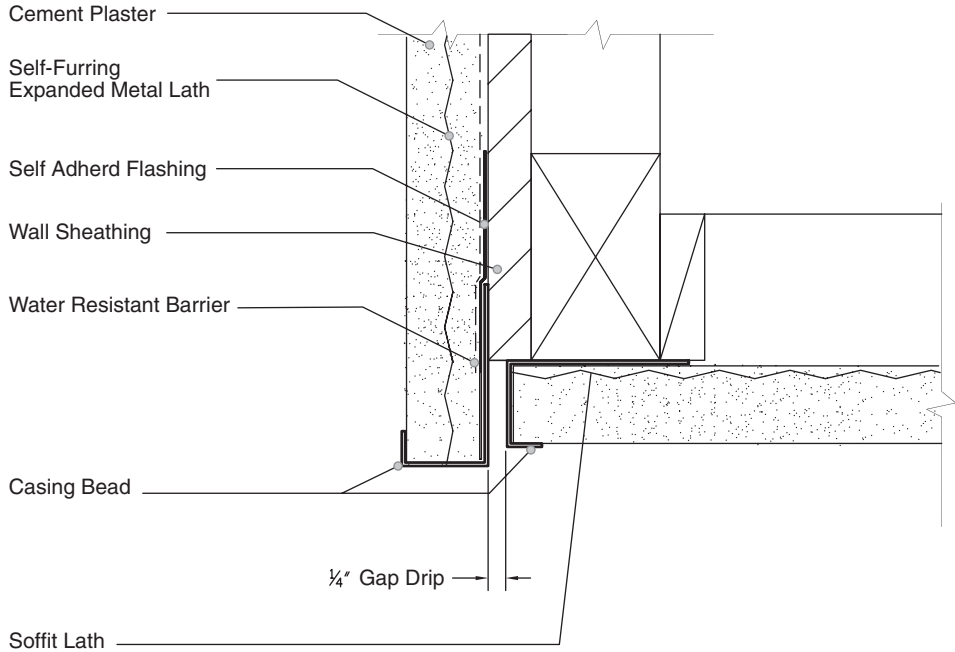

SOFFIT DRIP

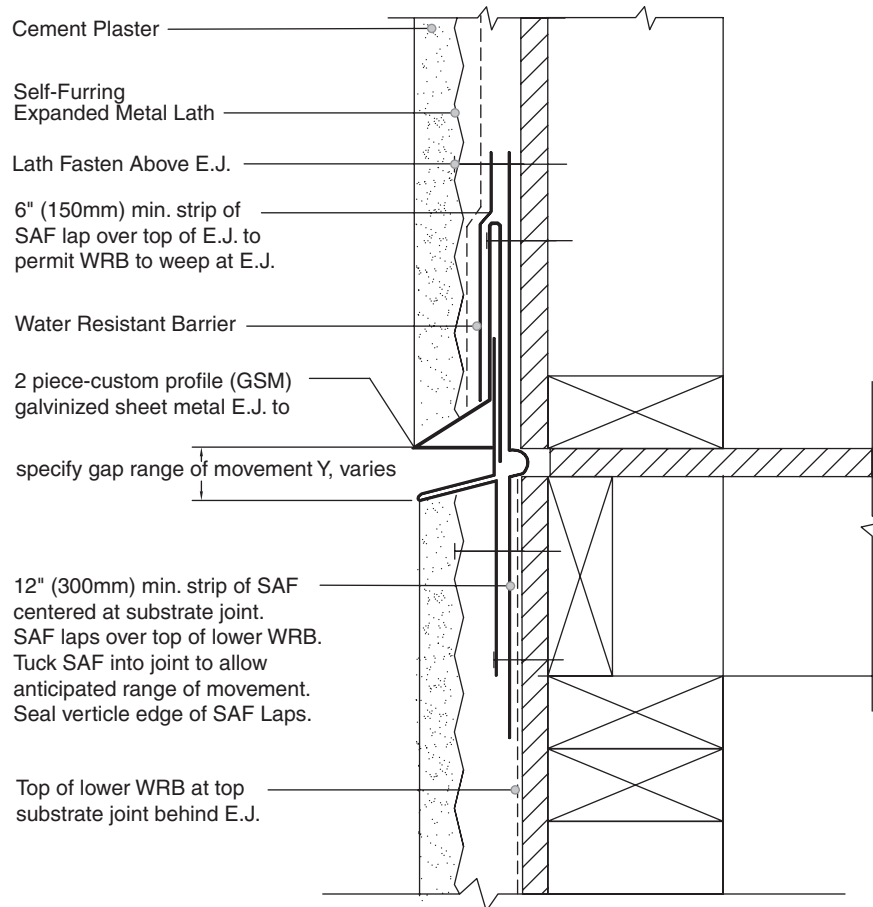

2-PIECE HORIZONTAL EXPANSION JOINT (E.J.)

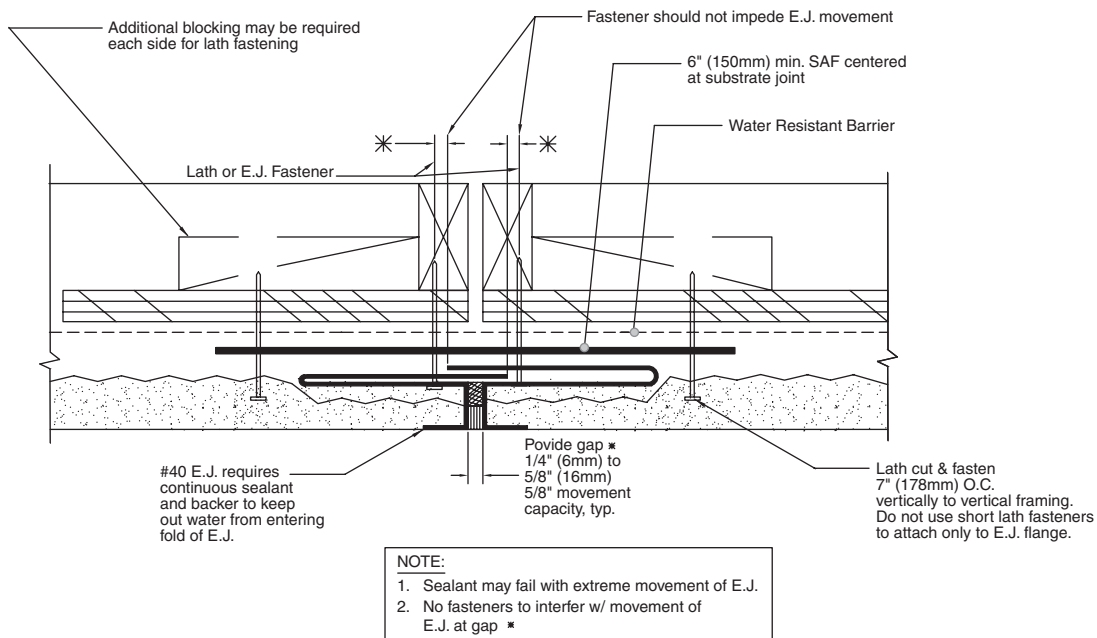

#40 VERTICAL EXPANSION JOINT (E.J.)

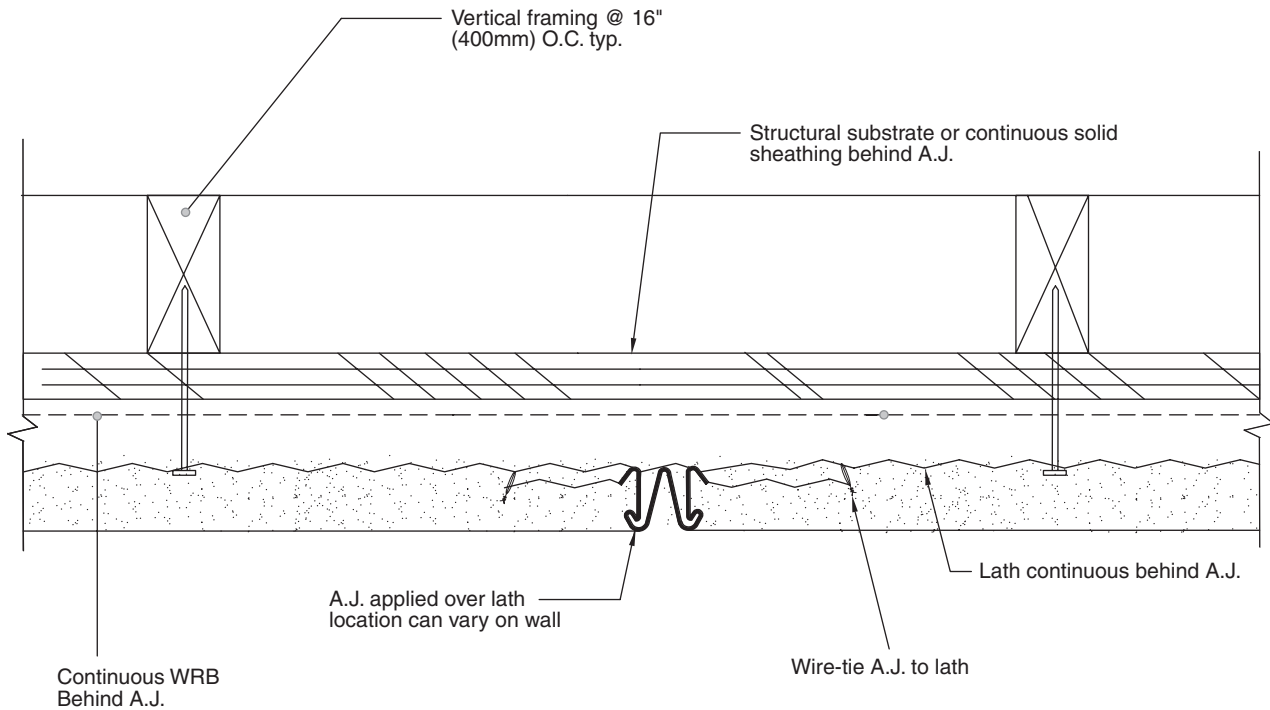

ARCHITECTURAL JOINT (A.J.) - VERTICAL

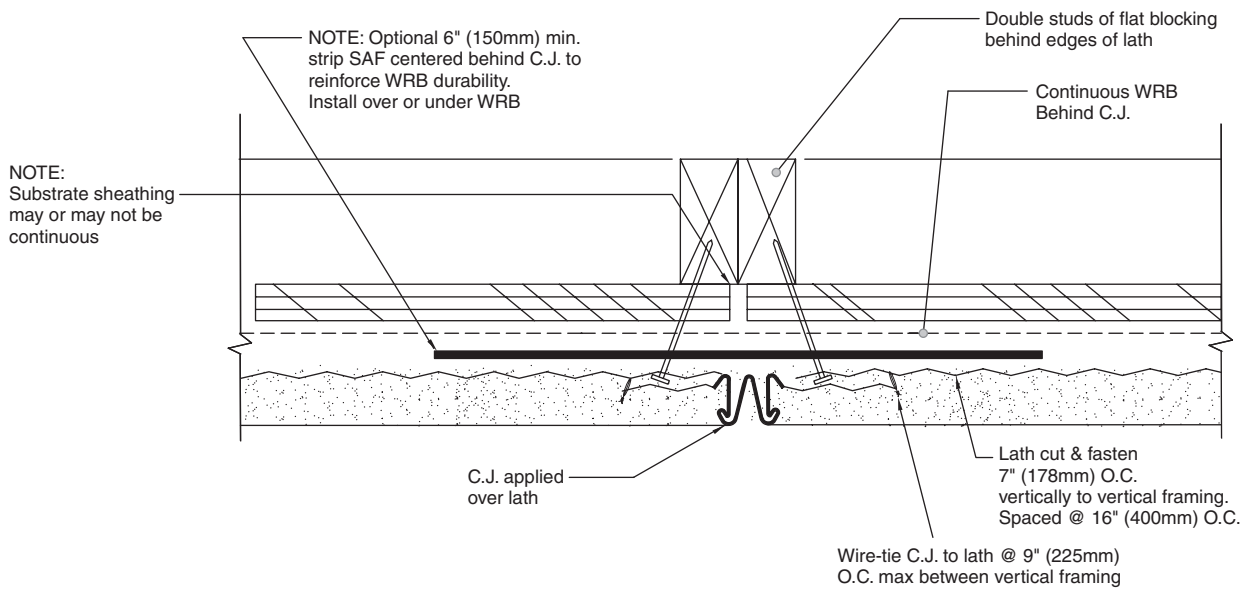

VERTICAL CONTROL JOINT (C.J.)

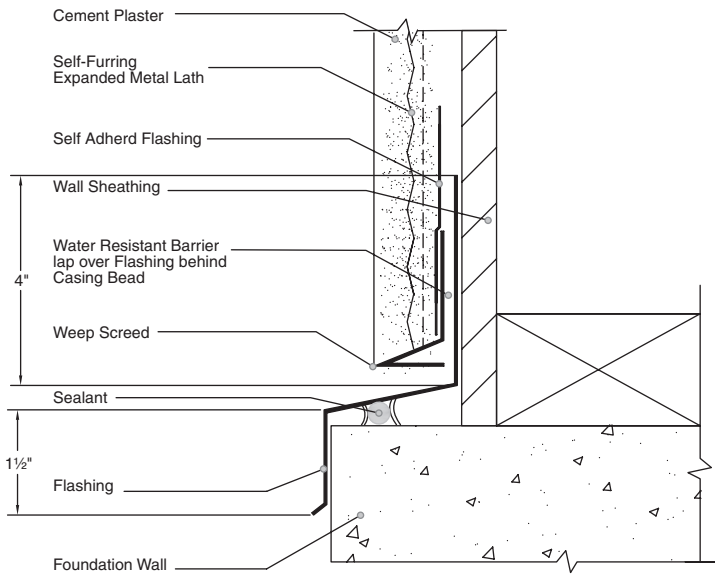

WEEP SCREED AT CONCRETE CURB

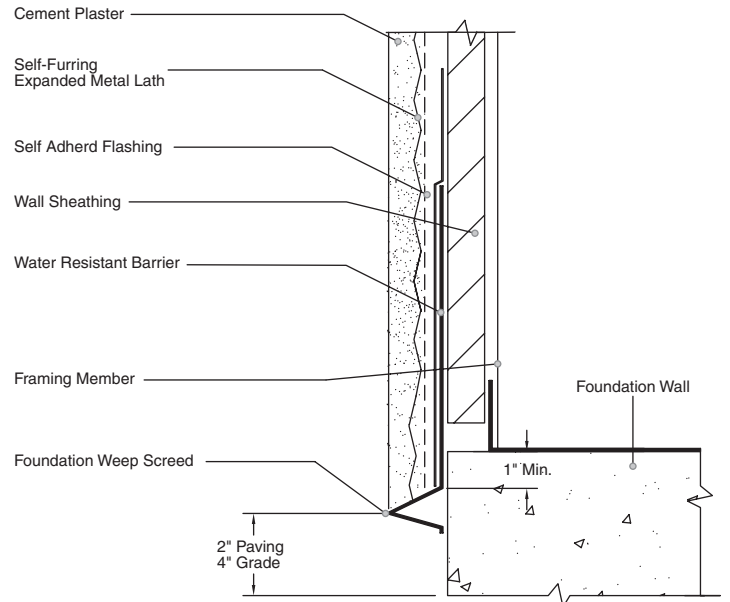

WEEP SCREED AT CONCRETE FOUNDATION

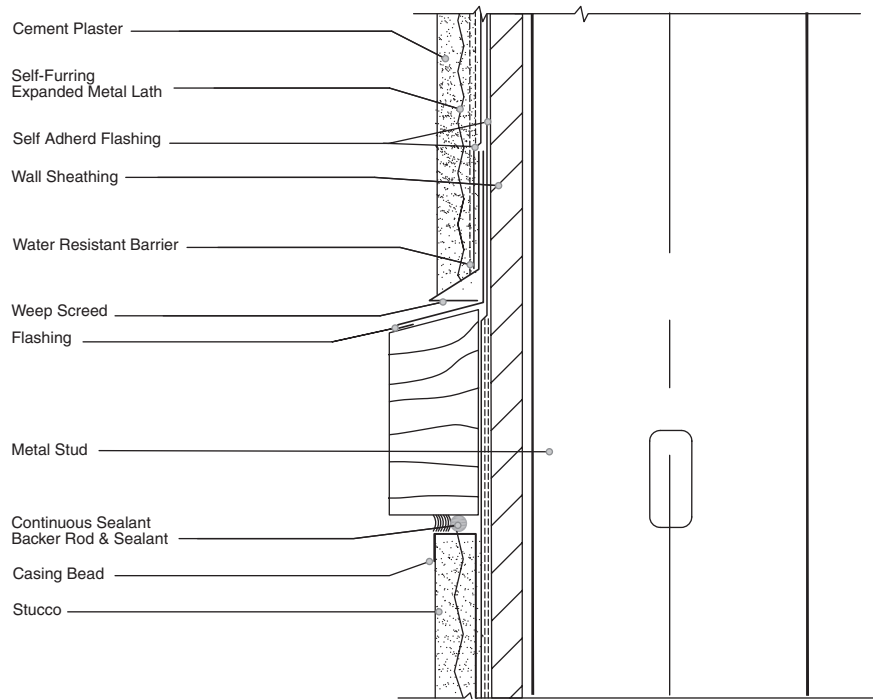

STUCCO TERMINATION AT DISSIMILAR MATERIAL

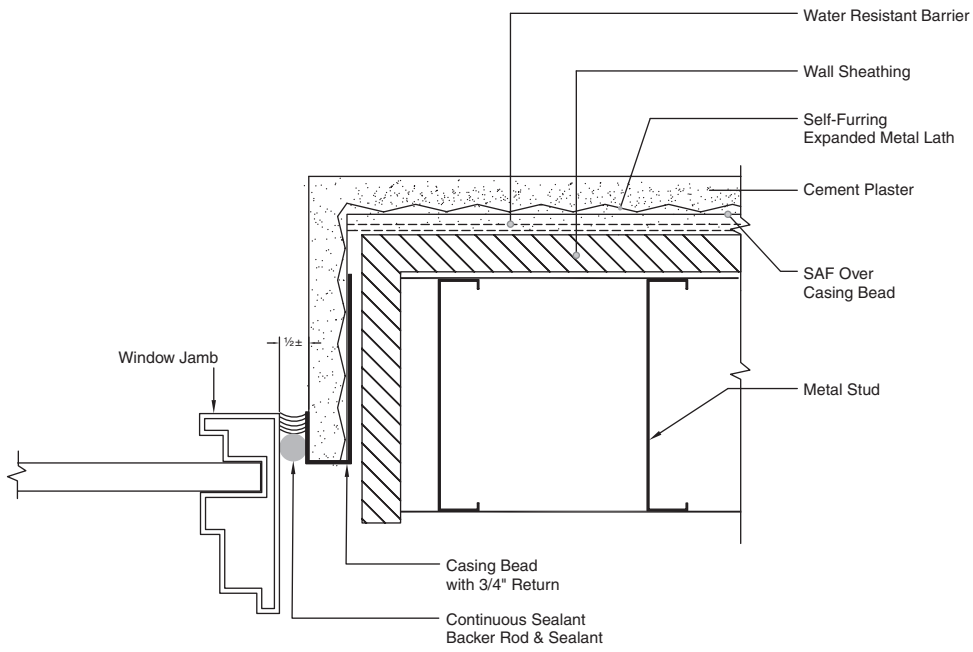

RECESSED WINDOW JAMB

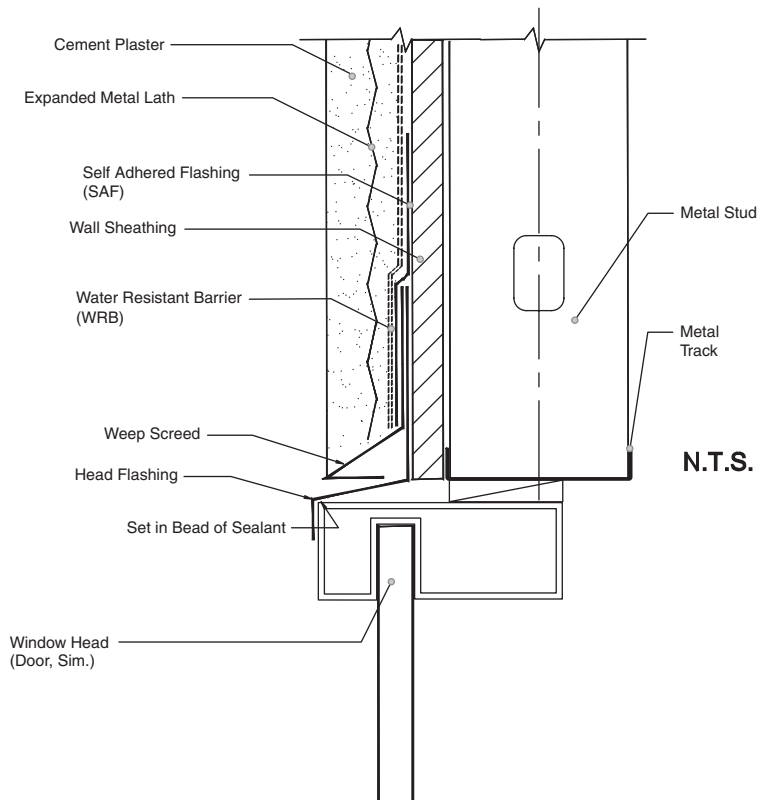

HEAD OF WINDOW

General Notes

- Plywood and OSB sheathing substrates should be classified as Exposure 1 or Exterior Grade.
- It is recommended that multistory wood frame construction include expansion joints at floor lines to compensate for wood shrinkage and structural compression. These issues however can be mitigated by engineered structural components that are more stable than dimensional lumber.
- It is recommended that wood framing and wood-based sheathing be reasonably dry with moisture content of 19% or less when the water-resistant barrier and lath are installed.
- It is recommended that wood-based sheathing panels be installed in accordance with APA requirements, with 1/8 inch spaces between all meeting panel edges.
- It is recommended that the building be carrying 90% of its dead load, prior to the installation of the stucco.
- Steel framing (on 16" centers) should be a minimum 3 1/2 inches wide with a minimum thickness of .0329 inches (20 gauge).
- The design deflection criteria for the structural system that the stucco system will be attached to must be L/360.
- A framing inspection should take place prior to a lath inspection. Appropriateness of flashings, treatments of penetrations and rough openings should be evaluated at that time.
- Wall penetrations such as electrical outlets, plumbing and vents should be completed and properly flashed or integrated to the water-resistive barrier prior to lath and stucco installation.
- Water-resistive barriers that have been adulterated by excessive exposure or damaged by tearing should be replaced prior to the application of stucco.
- Water-resistive barriers should be installed with staples that do not protrude through the back side of the sheathing.
- Water-resistive barrier should be installed flat and taut to the substrate surface.
- Lathers do not install windows. However, water-resistive barriers should be properly integrated with flashings for positive drainage.
- All flashings and water-resistive barriers should be installed for positive drainage.
- Metal flashing materials should be a minimum 26 gauge galvanized sheet metal or anodized, coil coated or painted aluminum.
- All trim accessories should be galvanized steel, zinc alloy or anodized aluminum.
- Trim accessories with an extended lip/embedment flange should be used to key stucco to the component.
- Joinery of abutting ends of trim accessories should be spliced or lapped and sealed with appropriate sealant.
- Joinery of control joint intersections should be spliced or lapped and sealed with appropriate sealant.
- Joinery of flashing sections should be appropriately lapped, sealed and mended together by application of sealants, adhesive backed membrane or other appropriate means of continuity.
- Types of control and expansion joints, if used, should be delineated on the contract drawings.
- The water-resistive barrier should remain unbroken behind control and expansion joints.
- Expansion joints when delineated on the contract drawings, should be located at points where significant building movement is anticipated: Wall penetrations, structural plate lines, junctures of dissimilar substrates, existing construction joints (such as in brick or block), columns and cantilevers.
- Installation of lath to concrete and concrete masonry units with drill and drive fasteners, power or powder actuated fasteners should be in accordance with manufacturer's recommendations.
- Pullout resistance of drill and drive fasteners, power or actuated fasteners should meet the requirements of the fastener manufacturer.
- If there is any question about the effectiveness of the pullout strength of drill and drive fasteners, power or powder actuated fasteners into concrete or concrete masonry block, a sample testing is recommended.
- Because stucco is a like-kind material to concrete or concrete block substrates, expansion joints in stucco in direct application over these substrates are dictated by whether a joint occurs in the substrate itself.
- Dissimilar substrates should be treated as separate stucco panel this can be done with a 2-piece expansion joint or Z-flashing weep screed combination.
- Drainage should be provided at all soffit corners including recessed windows heads.
- On multistory building each floor line should provide some type of drainage.
- Paint or acrylic finish coats can provide barrier type protection but drainage points should stay functional.

- The market is full of different types of water resistant barriers and adhesive backed sheet membranes not all are compatible with each other, follow all manufacturer's guidelines.
- Review window manufacturer's installation guidelines before installing water resistant barrier.
- Stucco terminations at penetrations should be sealed with sealant to the metal side of the flashing or stucco trims. Not to the face of the brown coat or finish coat.
- Stucco assemblies are not recommended for parapet caps, stair rail caps, or flat horizontal surfaces. Any slope less than 12:6 should have metal coping to prevent water infiltration.

Lathing and Stuccoing Terminology

Adhesive Backed Membrane: Adhesive backed rubber sheet membranes made with tear-off paper intermediate facers. Generally used in mitigating weather barrier and flashing installations.

Admixture: Products such as acrylic additives added in the basic stucco mix which improves the workability and performance characteristics of the end product.

Aesthetic Rustication: Grooves/reveals placed in plaster to delineate lines and shadowing effects.

Aggregate: Sand or other granular material used in the stucco mix.

Base Coat: The stucco composed of the two layers called the scratch coat and brown coat.

Bond: Adhesion of stucco to other surfaces in which it is applied; the adhesion of the cement paste to the aggregate; the adhesion between stucco coats.

Brown Coat: The second coat of stucco applied over the scratch coat.

Chopped Fibers: Fiberglass or other strand materials approximately 1/2 inch long used in the stucco mix to provide better cohesiveness.

Cold Joint: The aesthetically objectionable and noticeable joining of fresh stucco applied next to set stucco.

Cold Rolled Channel: A heavy gauged roll formed, "C" shaped metal fabrication used as the main lateral support or cross furring for a suspended plaster ceiling, sometimes referred to as "channel iron."

Contact Ceiling: A ceiling that has been constructed in direct contact with framing or floor above, without the benefit of main runners and furring.

Control Joint: A single component joint with an accordion shaped profile placed in a stucco membrane that opens and closes minimally as a result of the thermal expansion and contraction and normal shrinkage of stucco.

Corner Reinforcement: Components such as corner beads and corner aids, used to plumb, strengthen, gage and provide continuity between intersecting walls that meet at an outside corner.

Cross Furring: Roll formed channel attached perpendicular to the main runners for the attachment of metal lath in a suspended plaster ceiling.

Curing: The process by which stucco ultimately reaches its full hardness and strength.

Darby: A straight edged tool with handles, approximately 42 inches long made of magnesium alloy or wood. Used to float and smooth the fresh stucco brown coat.

Dash Coat: A wet plaster coat splatter applied to a surface as a final finish texture or to provide a mechanical key for a subsequent application of a brown coat.

Deflection: The limits at which an applied axial or wind load on a structural member will cause damage in a stucco membrane. The design deflection criteria for stucco should be $L/360$. That is the length of the span (in inches) divided by 360.

Double-back: The process of installing the brown coat immediately after the scratch coat has reached sufficient rigidity to accept it.

Drip Screed: A device used to interrupt the flow of water on a wall. A weep screed would be an example of this.

Expansion Joint: A two-piece or multiple component accessory placed in a stucco membrane that opens and closes due to movement primarily from structural stresses.

Finish Coat: The final decorative layer of either cementitious stucco and color pigment or an acrylic texture applied over the base coat.

Flashing: Approved corrosion-resistive material provided in such a manner as to deflect and resist entry of water into the construction assembly.

Floating: The process of compacting and leveling the stucco basecoat.

Fog Coat: A fine cement based color coat used to even out and provide uniformity in integrally colored stucco finishes.

Ground: That part of an accessory which establishes the thickness of the stucco and also mechanically keys to the stucco.

Hanger: Wire, threaded rod or metal strapping used to support main runners to the construction in a suspended plaster ceiling installation.

Hawk: A tool with a flat metal surface supported by a single handle that is used to hold plaster before it is transferred to a trowel for application.

Lath: The expanded metal, welded wire or woven wire that is attached to the building's structural elements and acts as an armature for the adhesion and mechanical key of the stucco.

Main Runner: See Cold Rolled Channel.

Mechanical Key: The process of roughening a surface for the subsequent application of plaster. See also scarifying, scratch coat and dash coat.

One Coat: A proprietary manufactured stucco base coat product that is installed in one thin application pass.

Reentrant Crack: A crack that develops at the natural stress point created at the corner of an opening or penetration such as at a window or door.

Reveals: Aesthetic grooves or rustication placed in plaster to delineate lines and shadowing effects.

Rod: A long straightedge (over 5 feet) made of magnesium alloy or wood that is used to rough plumb the face of a stucco wall.

Scarifying: The process of raking the fresh plaster surface to provide a mechanical key for the subsequent application of another coat of plaster.

Scratch Coat: The first coat of fresh stucco that is scarified to create a mechanical key for the subsequent brown coat.

Screed: An accessory or component that aids in gauging the thickness of the stucco. Casing beads, weep screeds, control joints and corner beads would all be considered screeding devices.

Self-furring: The term used to describe the dimples that offset the lath 1/4 inch away from the substrate so that it is embedded in the stucco.

Skim Coat: A finish coat applied over an existing stucco finish to improve its appearance.

Slicker: A wood or sometimes metal straight edge tool used in lieu of a darby to float and smooth a stucco surface to plumb.

Suction: The absorption capacity of a material to accept another product.

Tie Wire: Annealed soft temper steel wire used for a variety of lathing operations.

Trim Accessories: Components installed during the lathing installation such as casing beads, control joints, weep screeds, etc.

Weather-resistive Barrier: Correct terminology is water-resistive barrier, however, verbiage has not yet caught up in all documents. These are any of the variety of housewraps, building papers or felts that have been available to wrap the external sheathing of a building prior to the installation of the cladding. Water-resistive barrier and weather-resistive barrier are interchangeable in this document.

Fiber Faced Sheathing: Highly water resistant exterior grade gypsum sheathing covered with fiberglass, most brands are highly mold resistant.

Self Adhesive Flashing (SAF): Adhesive backed rubber sheet or butyl based membrane with tear off paper intermediate facer.

Drainage: The ability for moisture to escape from stucco assembly.

Acrylic Finish Coat: Premixed acrylic based wall coating varying in texture, color, and mil thickness.

House wrap: Is a term for a type of chemically based water resistant barrier other than building paper. The rolls are generally wider than building paper and come in a wide range of vapor and air permeability.

Moist Curing: Physically applying water generally with a spray nozzle to the face of the stucco once in the morning and once in the evening for the first 48 hours after the brown coat to slow down the curing process.

Grooved Expanded Metal Lath: Expanded metal lath with 1/4" self furring grooves rolled into the lath horizontally every 6"-7" to ensure proper fastening pattern without compromising furring.

3/8" Ribbed Lath: Combination of expanded metal lath and 3/8" deep ribs which provides rigidity for soffit applications.

Spray rib lath: Ribbed lath with strips of paper to prevent stucco from blowing through the lath during stucco spray application.

XJ15: Single piece control joint with expanded metal lath on both flanges and a double J screed profile.

Double V #15: Single piece control joint with expanded metal lath on both flanges and a double V or M screed profile.

Weep Screed: Also known as a Foundation Screed typically utilized at the base of a stucco panel to allow water to drain out of the stucco assembly.

Strip Lath: Rectangular strip of expanded metal lath installed at the corners of windows, doors, and penetration to help minimize cracking.

Casing Bead: Also known as "plaster stop", "#66", or "J-mold" used for stucco terminations.

