

INSTALLATION MANUAL

R-410A

**MODELS: NH-07 thru -20, 2-Pipe
NJ-10 thru -20, 4-Pipe**

7.5 - 20 Ton, 60 Hertz



TABLE OF CONTENTS

General	2	Duct Connections	10
Safety Considerations	2	Refrigerant Mains	10
Reference	2	Expansion Valve Bulb Installation	12
Agency Approvals	2	Air System Adjustment	13
Inspection	2	Electrical Connections	13
Nomenclature	3	Electrical Data	22
Unit Application Data	4	Airflow Performance	26
Physical Data Indoor Unit	5	Airflow Performance	27
Air Discharge Conversion	5	Twin Belt Drive Adjustment	35
Unit Installation	7	Sequence of Operation	36
Location	7	Maintenance	36
Rigging	7	Typical Wiring Diagrams	44
Clearances	7	Air Handling Units	44
Mounting	8	Start-Up Sheet	51

LIST OF TABLES

1 Unit Application Data Indoor	4	10 NH/NJ-10 Horizontal	28
2 Physical Data Indoor Unit	5	11 NH/NJ-15 Upflow	29
3 Minimum Clearances	7	12 NH/NJ-15 Horizontal	29
4 Corner Weights & Center of Gravity NH/NJ Units	9	13 NH/NJ-20 Upflow	30
5 Electrical Data - Evaporator Units	22	14 NH/NJ-20 Horizontal	30
6 Altitude/Temperature Correction Factors	25	15 RPM Selection	31
7 NH-07 Upflow	27	16 Additional Static Resistance	32
8 NH-07 Horizontal	27	17 Blower Motor And Drive Data	33
9 NH/NJ-10 Upflow	28	18 Piping, Electrical and Duct Opening Connection Sizes	43

LIST OF FIGURES

1 Vertical Airflow Arrangements	6	19 Typical Field Wiring Diagram - Twin NH-07 Evaporator Units with 4-Pipe Condenser Unit	21
2 Horizontal Airflow Arrangements	6	20 Altitude/Temperature Correction Factors	25
3 Typical Cabinet Assembly	7	21 Hole Location For Pressure Drop Reading	33
4 Typical Suspension of AHU's From Ceiling	8	22 Pressure Drop Across A Dry Indoor Coil vs. Supply Air CFM	34
5 Suggested Method For Connecting Ductwork	10	23 Belt Adjustment	35
6 Recommended Drain Piping	10	24 Double Groove Pulley	35
7 TVX Bulb Location	12	25 Unit Dimensions NH-07/-10 & NJ-10	37
8 Typical Field Wiring Diagram - NH-07 Evaporator Unit with PH-07 Heat Pump	13	26 Unit Dimensions NH/NJ-15	39
9 Typical Field Wiring Diagram - NH-10 thru -20 Evaporator Unit with PH-10 thru -20 Heat Pump	14	27 Unit Dimensions NH/NJ-20	41
10 NH-10 thru -20 Liquid Line Solenoid Wiring	14	28 Typical NH-07 Wiring Diagram	44
11 Typical Field Wiring Diagram - NJ-15 thru -20 Evaporator Unit with PJ-15 thru -20 Heat Pump	15	29 Typical NH-10 thru -20, 1.5 Thru 5 HP Blower Motor Only Wiring Diagram	45
12 Typical Field Wiring Diagram - NH-07 Evaporator Unit with YH-07 Condenser Unit	16	30 Typical NH-20, 7.5 HP Blower Motor 208/230 V Only Wiring Diagram	46
13 Typical Field Wiring Diagram - NH-10 thru -20 Evaporator Unit with YH-10 thru -20 Condenser Unit	17	31 Typical NH-20, 7.5 HP Blower Motor 460/575 V Only Wiring Diagram	47
14 NH-10 thru -20 Liquid Line Solenoid Wiring	17	32 Typical NJ-10 thru -20, 1.5 Thru 5.0 HP Blower Motor Only Wiring Diagram	48
15 Typical Field Wiring Diagram - NJ-10 thru -20 Evaporator Unit with YJ-10 thru -20 Condenser Unit	18	33 Typical NJ-20, 7.5 HP Blower Motor 208/230 V Only Wiring Diagram	49
16 Typical Field Wiring Diagram - Twin NH-10 thru -20 Evaporator Units with 4-Pipe Condenser Unit	19	34 Typical NJ-20, 7.5 HP Blower Motor 460/575 V Only Wiring Diagram	50
17 NH-10 thru -20 Liquid Line Solenoid Wiring	19		
18 Typical Field Wiring Diagram - Single 4-Pipe Evaporator Unit with Twin Condenser Units	20		

General

These completely assembled 7-1/2 thru 20 ton evaporator blower units include a well insulated cabinet, a DX cooling coil with copper tubes and aluminum fins, expansion valve(s), distributor(s), throwaway filters, centrifugal blower(s), blower motor, completely wired control box and a small holding charge of dry nitrogen. Blower motors and adjustable drives are factory-installed on all units.

Supplemental resistance heaters, supply air plenums, return air grills, hot water coils, non-freeze steam coils, and bases are available as accessories for field installation.

The units are shipped in the vertical position ready for field installation.

Safety Considerations

Installer should pay particular attention to the words: *NOTE*, *CAUTION*, and *WARNING*. Notes are intended to clarify or make the installation easier. Cautions are given to prevent equipment damage. Warnings are given to alert installer that personal injury and/or equipment damage may result if installation procedure is not handled properly.

WARNING

Improper installation may create a condition where the operation of the product could cause personal injury or property damage.

Improper installation, adjustment, alteration, service or maintenance can cause injury or property damage. Refer to this manual for assistance or for additional information, consult a qualified contractor, installer or service agency.

CAUTION

This system uses R-410A Refrigerant which operates at higher pressures than R-22. No other refrigerant may be used in this system. Gage sets, hoses, refrigerant containers and recovery systems must be designed to handle R-410A. If you are unsure, consult the equipment manufacturer. Failure to use R-410A compatible servicing equipment may result in property damage or injury.

Reference

This instruction covers the installation and operation of evaporator blower units. For information on the operation of matching condensing units, refer to Installation Manual - 430646 for cooling units and Installation Manual - 430647 for heat pumps.

Additional information on the design, installation, operation and service of this equipment is available in the Technical Guide - 505430.

Renewal Parts

Contact your local Source 1 parts distribution center for authorized replacement parts.

Agency Approvals

Design certified by CSA as follows:

1. For use as a (cooling coil, heat pump coil/air handler) only with or without supplemental electric heat.
2. For indoor installation only.

Inspection

As soon as a unit is received, it should be inspected for possible damage during transit. If damage is evident, the extent of the damage should be noted on the carrier's freight bill. A separate request for inspection by the carrier's agent should be made in writing.

CAUTION

This product must be installed in strict compliance with the enclosed installation instructions and any applicable local, state and national codes including, but not limited to, building, electrical, and mechanical codes.

WARNING

Wear safety glasses and gloves when handling refrigerants. Failure to follow this warning can cause serious personal injury.

Nomenclature

Configured Split Air Handler Model Number Nomenclature

N H -20 C00 B S A AA 3 A

Product Category
N = Split System, Air Handler, AC & HP, R-410A

Product Identifier
H = Standard Efficiency, 2-Pipe, R-410A
J = Standard Efficiency, 4-Pipe, R-410A

Nominal Cooling Capacity - MBH
-07 = 7.5 Ton
-10 = 10 Ton
-15 = 15 Ton
-20 = 20 Ton
-25 = 25 Ton

Heat Type & Nominal Heat Capacity
C00 = Cooling Only

Airflow
B = 1.5 HP Motor
C = 2.0 HP Motor
D = 3 HP Motor
E = 5 HP Motor
F = 7.5 HP Motor
N = None (Motor Drive Kit Req)¹

1. Motors are not shipped with 25 ton Air Handler Units.

Installation Options
A = None

Voltage
T = 208/230-3-60²
W = 460-3-60²
S = 208/230/460-3-60
X = 575-3-60

2. NH/NJ-20 Airflow Option "F" Only.

Product Style
A = Style A

Product Generation
1 = First Generation
2 = Second Generation
3 = Third Generation

Product Options
AA = No Options Installed
EJ = E-Coat Evaporator Coil
TJ = Technicoat Evaporator Coil

Unit Application Data

Table 1: Unit Application Data Indoor

Model	Power Supply Voltage	Voltage Variation		Supply Air Range CFM		Entering Air Temperature Degrees °F			
						Cooling DB/WB		Heating DB ¹	
		Min.	Max.	Min.	Max.	Min.	Max.	Min.	Max.
NH-07	208/230-3-60	187	253	2,250	3,750	65/57	90/77	40	80
	460-3-60	414	506	2,250	3,750	65/57	90/77	40	80
	575-3-60	540	630	2,250	3,750	65/57	90/77	40	80
NH-10	208/230-3-60	187	253	3,000	5,000	65/57	90/77	40	80
	460-3-60	414	506	3,000	5,000	65/57	90/77	40	80
	575-3-60	540	630	3,000	5,000	65/57	90/77	40	80
NJ-10	208/230-3-60	187	253	3,000	5,000	65/57	90/77	40	80
	460-3-60	414	506	3,000	5,000	65/57	90/77	40	80
	575-3-60	540	630	3,000	5,000	65/57	90/77	40	80
NH-15	208/230-3-60	187	253	4,500	7,500	65/57	90/77	40	80
	460-3-60	414	506	4,500	7,500	65/57	90/77	40	80
	575-3-60	540	630	4,500	7,500	65/57	90/77	40	80
NJ-15	208/230-3-60	187	253	4,500	7,500	65/57	90/77	40	80
	460-3-60	414	506	4,500	7,500	65/57	90/77	40	80
	575-3-60	540	630	4,500	7,500	65/57	90/77	40	80
NH-20	208/230-3-60	187	253	6,000	10,000	65/57	90/77	40	80
	460-3-60	414	506	6,000	10,000	65/57	90/77	40	80
	575-3-60	540	630	6,000	10,000	65/57	90/77	40	80
NJ-20	208/230-3-60	187	253	6,000	10,000	65/57	90/77	40	80
	460-3-60	414	506	6,000	10,000	65/57	90/77	40	80
	575-3-60	540	630	6,000	10,000	65/57	90/77	40	80

1. Heating Min/Max temperatures apply to steam and hot water coils. NOTE: Do not apply steam to hot water coils.

Physical Data Indoor Unit

Table 2: Physical Data Indoor Unit

Component	Models						
	NH-07	NH-10	NJ-10	NH-15	NJ-15	NH-20	NJ-20
Nominal Tonnage	7 1/2	10	10	15	15	20	20
DIMENSIONS (inches)							
Length	56.0	56.0	56.0	74.5	74.5	98.5	98.5
Width	30.0	30.0	30.0	33.0	33.0	30.0	30.0
Height	65.0	65.0	65.0	75.0	75.0	65.0	65.0
WEIGHTS (lb)							
Unit Shipping	526	573	575	796	796	938	938
Unit Operating With							
Standard Motor and Drive	498	539	541	764	764	873	873
High Static Motor and Drive	500	550	552	792	792	903	903
INDOOR BLOWER (Forward Curve)							
Diameter x Width	12 x 12	15 x 15	15 x 15	18 x 18	18 x 18	15 x 15	15 x 15
Quantity	1	1	1	1	1	2	2
INDOOR COIL							
Face area (Sq. Ft.)	10.6	10.6	10.6	18.3	18.3	20.0	20.0
Rows	3	4	4	3	4	4	4
Fins per inch	15	15	15	15	15	15	15
Tube diameter	3/8	3/8	3/8	3/8	3/8	3/8	3/8
Circuitry Type	Interlaced	Interlaced	Interlaced	Interlaced	Interlaced	Interlaced	Interlaced
Refrigerant Control	TXV	TXV	TXV	TXV	TXV	TXV	TXV
SYSTEM DATA							
No. Refrigeration Circuits	1	1	2	1	2	1	2
Suction Line OD (in.)	1 1/8	1 3/8	1 1/8	1 5/8	1 3/8	1 5/8	1 3/8
Liquid Line OD (in.)	5/8	7/8	5/8	7/8	5/8	7/8	7/8
FILTERS							
Size and Quantity Per Model (In.)	16 x 25 x 2	4	4	4	---	---	8
	20 x 24 x 2	---	---	---	6	6	---
Face area (Sq. Ft.)							
Size and Quantity Per Model (In.)	16 x 25 x 4	4	4	4	---	---	8
	18 x 24 x 4	---	---	---	6	6	---
Face area (Sq. Ft.)							
	11.1	11.1	11.1	18.0	18.0	22.2	22.2

Air Discharge Conversion

These units are shipped for Vertical Airflow operation as seen in Figure 1 Position 1, but may be converted to Positions 2 thru 8 as well as for Horizontal Airflow operation illustrated in Figure 2 Positions 1 thru 8.

NOTE: Units that require bottom return conversion for vertical airflow operation Figure 1 positions 5, 6, 7, 8 and horizontal air flow operation Figure 2 positions 5, 6, 7 and 8 require a field installed bottom return kit.

1BP0401 for 7.5 AND 10 TON

1BP0402 for 15 TON

1BP0403 for 20 TON

Conversion Example:

Convert Vertical Airflow Position 1 to Horizontal Airflow Position 1 as follows:

1. Remove the front panel from the blower section and set aside. Save the screws for Step 8.
2. Remove the four bolts that hold the coil section and blower section together. Save the bolts for Step 6.
3. Set the blower section aside.
4. Remove the evaporator section rear panel and set aside. Save the screws for Step 7.
5. Rotate the blower section and mate it to the hole left by removing the panel in Step 4.
6. Bolt the two sections together using the four 3/8" nut inserts provided with the bolts removed in Step 2.
7. Place the panel removed in Step 4 on top of the evaporator section and screw together.
8. Replace the panel removed in Step 1 on the blower section and screw together.

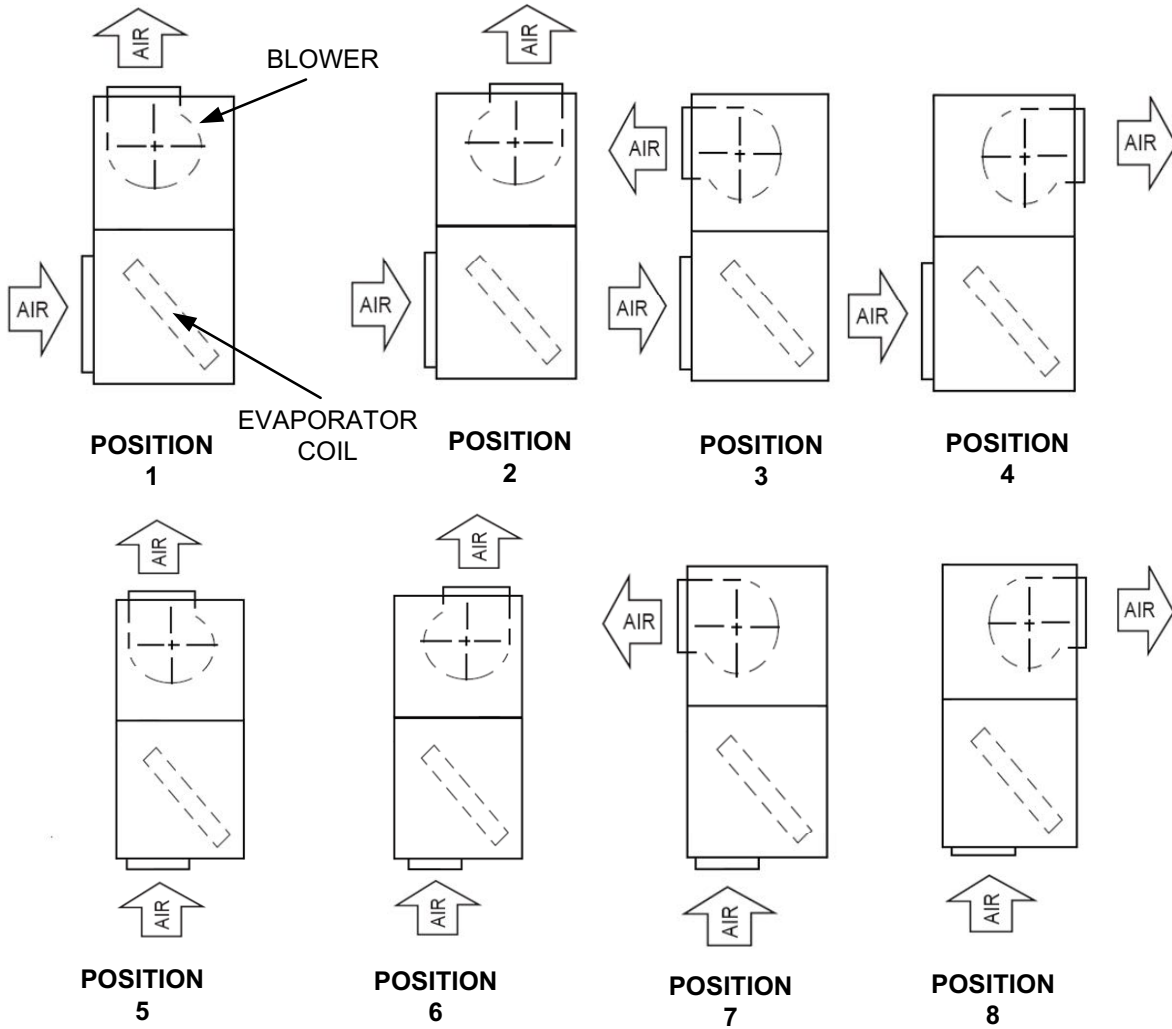

Figure 1: Vertical Airflow Arrangements

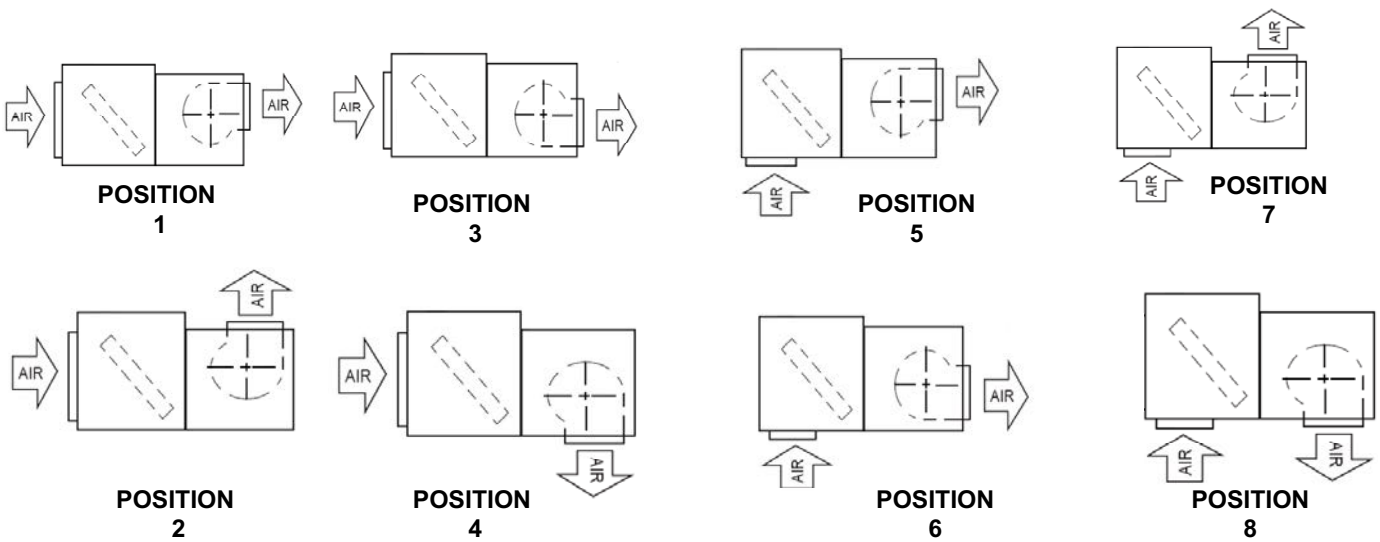

Figure 2: Horizontal Airflow Arrangements

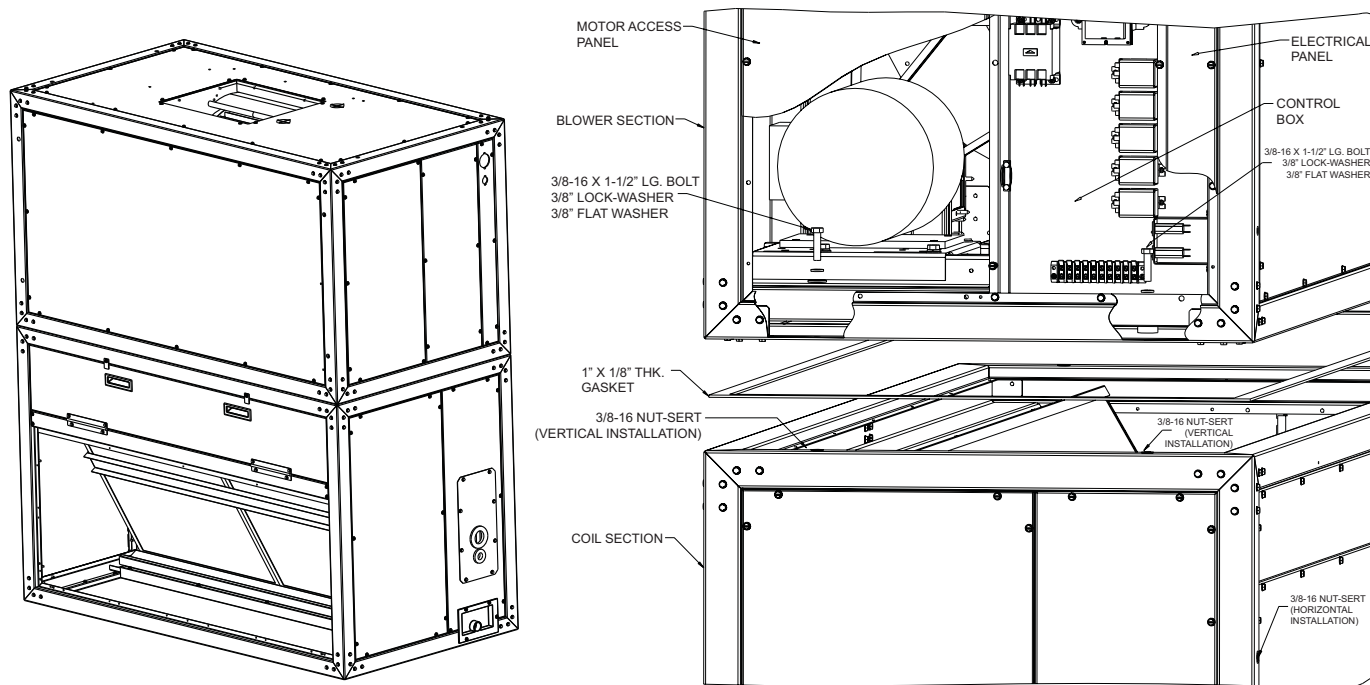

Figure 3: Typical Cabinet Assembly

Unit Installation

Location

This split system evaporator unit is not designed for outdoor installation. It must be located inside a building structure, either inside or outside the conditioned space where it is protected from rain and other moisture.

The unit should be located as close to the condenser unit/heat pump as practical and positioned to minimize bends in the refrigerant piping.

This unit can be installed vertically or horizontally and can be set directly on a floor or platform, or supported by metal or wooden beams.

Rigging

Care must be taken when moving the unit. Do not remove any packaging until the unit is near the place of installation. SPREADER BARS SHOULD BE USED BETWEEN THE SLINGS TO PREVENT CRUSHING THE UNIT FRAME OR PANELS. When preparing to move the unit, always determine the center of gravity of the unit in order to equally distribute the weight. Rig the unit by attaching chain or cable slings around the bottom skid. A lift truck may be used to raise a unit to a suspended location. Refer to Table 4 for unit weights.

Clearances

Table 3: Minimum Clearances

Minimum Clearances	
Top with Supply Air Opening ¹	24"
Front with Return Air Opening	24"
Right Side with Access for Piping, Power & Control Wiring Connections ²	24"
Left Side	24"
Rear ³	N/A
Bottom ⁴	N/A

1. This dimension will vary if an electric heater, a supply air plenum or a base is used.
2. This dimension is required for normal installation and service.
3. Although no clearance is required for service and operation, some clearance may be required for routing the power and control wiring.
4. Allow enough clearance to trap the condensate drain line.

NOTE: If the coil has to be removed, the blower section can be unbolted and set aside and the coil can be lifted out the top of the evaporator section.

Mounting

The split system evaporator unit can be applied in various horizontal positions. Figure 4 shows recommended suspension rigging using properly sized all-thread and metal c-channel. All

components to suspend the unit must be field supplied. Please refer to the unit's total weight, center of gravity and corner weights (Horizontal position) shown in the appropriate table for proper support sizing.

END VIEW

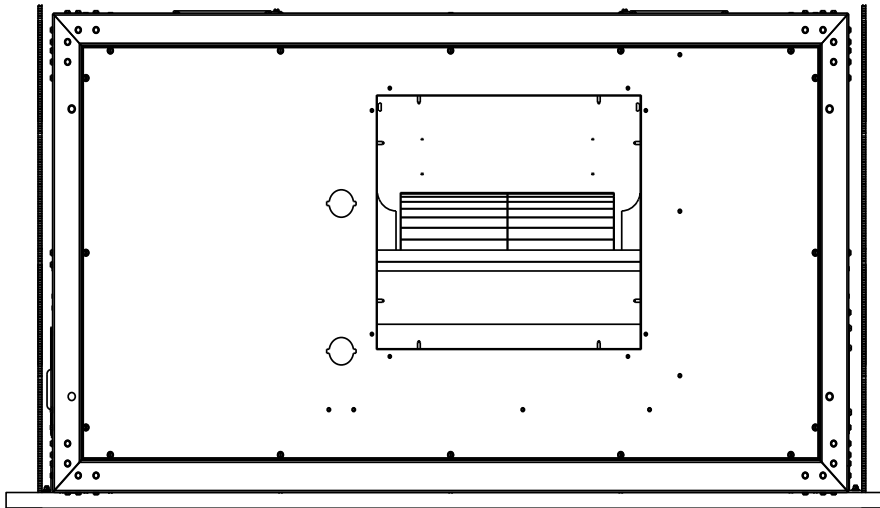

MOUNTING DETAIL

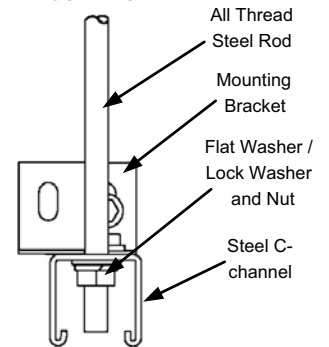

SIDE VIEW

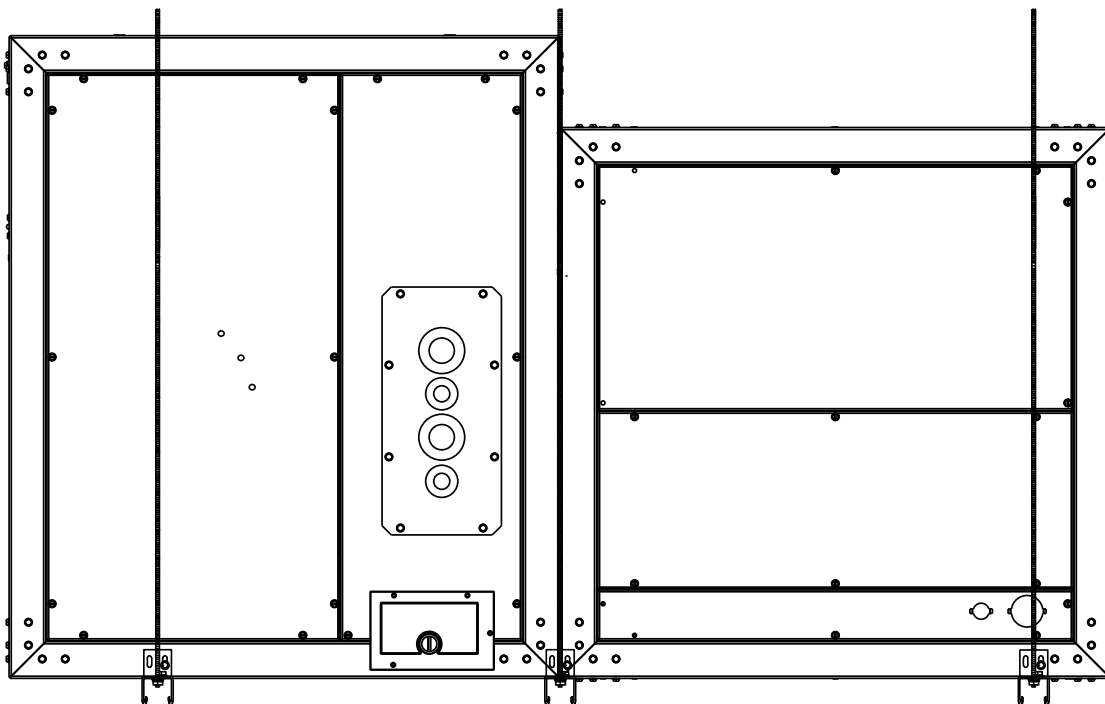
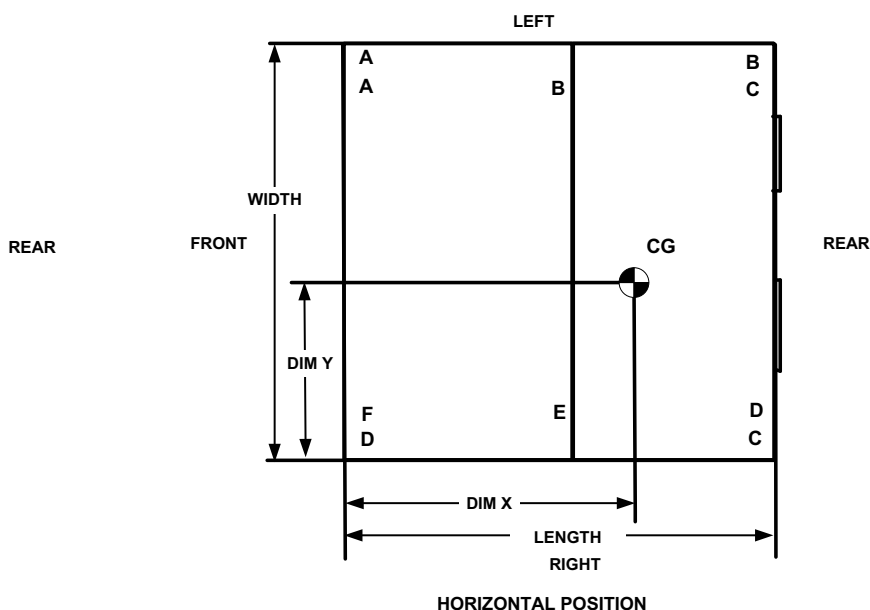
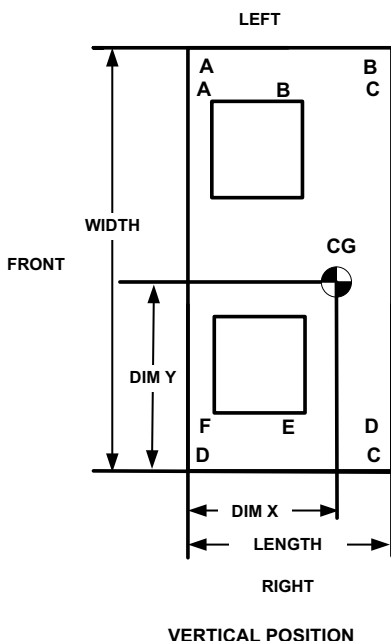

Figure 4: Typical Suspension of AHU's From Ceiling

Table 4: Corner Weights & Center of Gravity NH/NJ Units

Model	Drive Options	Weight (lbs.)		Center of Gravity (in.)		4 Point Load Location (lbs.)				6 Point Load Location (lbs.)					
		Shipping	Operating	X	Y	A	B	C	D	A	B	C	D	E	F
Vertical Airflow															
NH-07	Std. Mtr. and Drv.	524	498	16.2	26.7	109	128	141	120	71	79	88	97	86	78
	High Static Mtr. and Drv.	526	500	16.2	26.7	110	129	142	120	71	79	88	97	87	78
NH-10	Std. Mtr. and Drv.	562	539	15.5	26.8	125	134	146	136	82	86	90	98	94	89
	High Static Mtr. and Drv.	573	550	15.5	26.7	127	136	148	139	84	87	91	100	96	91
NJ-10	Std. Mtr. and Drv.	564	541	15.5	26.9	126	135	145	136	83	87	91	98	94	89
	High Static Mtr. and Drv.	575	552	15.5	26.9	128	137	148	138	84	88	92	100	95	91
NH-15	Std. Mtr. and Drv.	796	764	18.2	35.8	164	203	219	178	106	121	140	151	131	114
	High Static Mtr. and Drv.	824	792	18.2	35.8	170	210	227	184	110	126	145	157	136	118
NJ-15	Std. Mtr. and Drv.	796	764	18.2	35.8	164	203	219	178	106	121	140	151	131	114
	High Static Mtr. and Drv.	824	792	18.2	35.8	170	210	227	184	110	126	145	157	136	118
NH-20	Std. Mtr. and Drv.	908	873	15.8	42.6	179	198	260	235	118	125	134	176	165	154
	High Static Mtr. and Drv.	938	903	15.7	42.4	185	204	269	245	122	129	138	182	171	161
NJ-20	Std. Mtr. and Drv.	908	873	15.8	42.6	179	198	260	235	118	125	134	176	165	154
	High Static Mtr. and Drv.	938	903	15.7	42.4	185	204	269	245	122	129	138	182	171	161
Horizontal Airflow															
NH-07	Std. Mtr. and Drv.	524	498	30.1	26.7	118	119	131	130	79	79	79	87	87	87
	High Static Mtr. and Drv.	526	500	30.1	26.7	119	120	132	130	79	79	80	88	87	87
NH-10	Std. Mtr. and Drv.	562	539	29.9	26.8	129	129	140	141	86	86	86	94	94	94
	High Static Mtr. and Drv.	573	550	30.2	26.7	130	132	145	142	87	87	88	97	96	95
NJ-10	Std. Mtr. and Drv.	564	541	29.9	26.9	131	130	140	141	87	87	86	93	94	94
	High Static Mtr. and Drv.	575	552	30.2	26.9	132	133	144	142	88	88	89	96	96	95
NH-15	Std. Mtr. and Drv.	796	764	33.7	35.8	179	187	203	194	119	122	126	136	132	128
	High Static Mtr. and Drv.	824	792	34.4	35.8	182	198	214	197	120	127	134	145	137	130
NJ-15	Std. Mtr. and Drv.	796	764	33.7	35.8	179	187	203	194	119	122	126	136	132	128
	High Static Mtr. and Drv.	824	792	34.4	35.8	182	198	214	197	120	127	134	145	137	130
NH-20	Std. Mtr. and Drv.	908	873	30.1	42.6	188	189	249	247	125	126	126	166	165	164
	High Static Mtr. and Drv.	938	903	30.6	42.4	191	198	262	252	126	130	133	176	171	167
NJ-20	Std. Mtr. and Drv.	908	873	30.1	42.6	188	189	249	247	125	126	126	166	165	164
	High Static Mtr. and Drv.	938	903	30.6	42.4	191	198	262	252	126	130	133	176	171	167



Duct Connections

Ductwork should always be suspended with hangers or supported by legs. It should never be fastened directly to the building structure.

Allow clearance around ducts for safety in the handling of heated air and for insulation when required.

Insulation

Ductwork insulation should meet the following criteria:

- Be used when ducts pass through an unconditioned space in the cooling season or through an unheated space during the heating season.
- Include a vapor barrier around the outside to prevent the absorption of moisture.
- Be no less than 2 inches thick with a weatherproof coating when applied to ducts exposed to outdoor conditions.

Supply Air Ducts

See Figure 5 for suggested method of connecting supply air ductwork. Non-flammable material collars should be used to minimize the transmission of noise and/or vibration.

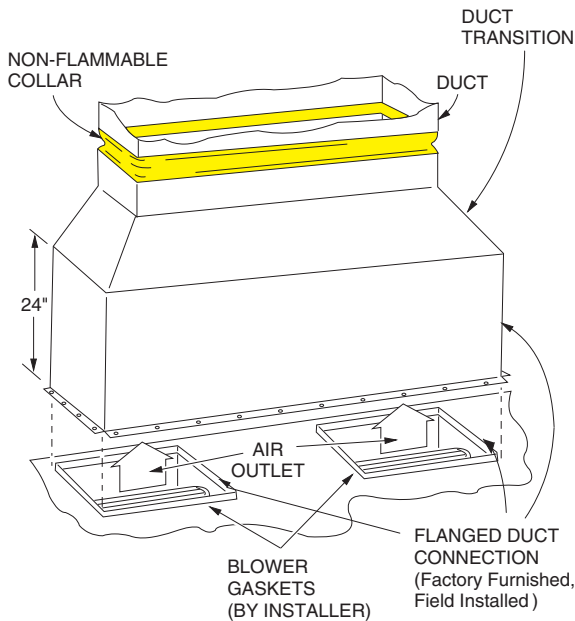

Figure 5: Suggested Method For Connecting Ductwork

Drain Connections

All drain lines **MUST** be trapped and located so they will not be exposed to freezing temperatures.

All evaporator blower units have a 3/4" ABS condensate stub at the end of a double sloped drain pan. The drain pan is removable and reversible, It can be unscrewed and slid out from one side of the evaporator section and installed in the other end.

NOTE: Consult local plumbing codes for type of glue required for drain connection.

Drain piping should be constructed as shown in Figure 6. The 3-inch dimension must equal or exceed the negative static pressure developed by the supply air blowers. If it does not, the condensate will not drain properly and may overflow the drain pan.

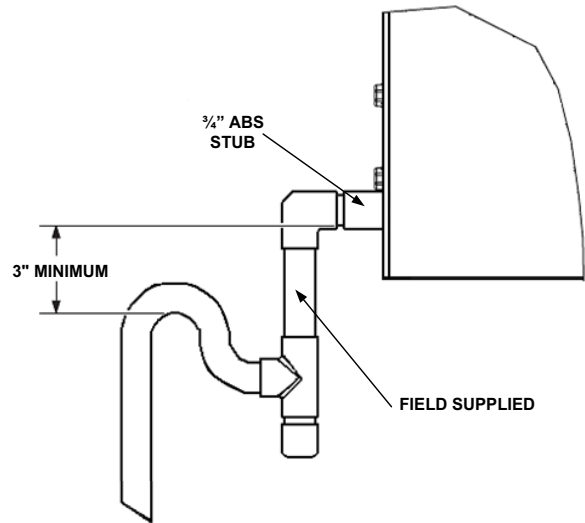

Figure 6: Recommended Drain Piping

Refrigerant Mains

CAUTION

This Split-System (Air Condensing / Heat Pump / Air Handling) unit is one component of an entire system. As such it requires specific application considerations with regard to the rest of the system (air handling unit, duct design, condensing unit, refrigerant piping and control scheme).

Failure to properly apply this equipment with the rest of the system may result in premature failure and/or reduced performance / increased costs. Warranty coverage specifically excludes failures due to improper application and Unitary Products specifically disclaims any liability resulting from improper application.

Please refer to the equipment Technical Guide, Installation Manual and the piping applications bulletin 247077 or call the applications department for Unitary Products @ 1-877-UPG-SERV for guidance.

Line Sizing

When sizing refrigerant pipe for a split-system air conditioner, check the following:

1. Suction line pressure drop due to friction.

2. Liquid line pressure drop due to friction.
3. Suction line velocity for oil return.
4. Liquid line pressure drop due to vertical rise. For certain piping arrangements, different sizes of suction line pipe may have to be used. The velocity of the refrigerant vapor must always be great enough to carry the oil back to the compressor.
5. **Evaporator Located Below Condenser** - On a split system where the evaporator blower is located below the condenser, the suction line must be sized for both pressure drop and for oil return.
6. **Condenser Located Below Evaporator** - When the condenser is located below the evaporator blower, the liquid line must be designed for the pressure drop due to both friction loss and vertical rise. If the pressure drop due to vertical rise and friction exceeds 60 psi, some refrigerant will flash before it reaches the thermal expansion valve.

Flash gas:

1. Increases the liquid line pressure loss due to friction that in turn causes further flashing.
2. Reduces the capacity of the refrigerant control device which starves the evaporator.
3. Erodes the seat of the refrigerant control device.
4. Causes erratic control of the refrigerant entering the evaporator.

Take Adequate Precautions

Many service problems can be avoided by taking adequate precautions to provide an internally clean and dry system and by using procedures and materials that conform to established standards.

Use hard drawn copper tubing where no appreciable amount of bending around pipes or other obstructions is necessary. If soft copper is used, care should be taken to avoid sharp bends that may cause a restriction. Pack fiberglass insulation and a sealing material such as permagum around refrigerant lines where they penetrate a wall to reduce vibrations and to retain some flexibility.

Support all tubing at minimum intervals with suitable hangers, brackets or clamps.

Braze all copper-to-copper joints with Silfos-5 or equivalent brazing material. Do not use soft solder. Insulate all suction lines with a minimum of 1/2" ARMAFLEX or equivalent that meets local code. Liquid lines exposed to direct sunlight and/or high temperatures must also be insulated. Never solder suction and liquid lines together. They can be taped together for convenience and support purposes, but they must be completely insulated from each other.

Before beginning installation of the main lines, be sure that the evaporator section has not developed a leak in transit. Check pressure at the Schrader valve located on the header of each coil. If pressure still exists in the system, it can be assumed to

be leak free. If pressure DOES NOT exist the section will need to be repaired before evacuation and charging is performed.

A filter-drier MUST be field-installed in the liquid line of every system to prevent dirt and moisture from damaging the system. Properly sized filter-driers are shipped with each condensing section.

NOTE: Installing a filter-drier does not eliminate the need for the proper evacuation of a system before it is charged.

A field-installed moisture indicating sight-glass should be installed in the liquid line(s) between the filter-drier and the evaporator coil. The moisture indicating sight-glass can be used to check for excess moisture in the system.

The evaporator coil has copper sealing disks brazed over the ends of the liquid and suction connections. The temperature required to make or break a brazed joint is high enough to cause oxidation of the copper unless an inert atmosphere is provided.

NOTE: Dry Nitrogen should flow through the system at all times when heat is being applied and until the joint has cooled. The flow of Nitrogen will prevent oxidation of the copper lines during installation.

Always punch a small hole in sealing disks before unbrazing to prevent the pressure in the line from blowing them off. Do not use a drill as copper shavings can enter system.

NOTE: Solenoid and hot gas bypass valves (if used) should be opened manually or electrically during brazing or evacuating.

NOTE: Schrader valves located on unit service valves should have their stem removed during brazing to prevent damage to the valve.

Start Installation

Start Installation of main lines at the condenser unit. Verify the service valves are fully seated by screwing the stem of both valves down into the valve body until it stops. Remove the Schrader valve stem and connect a low-pressure nitrogen source to the service port on the suction line valve body. Punch a small hole in the sealing disk; the flow of Nitrogen will prevent any debris from entering the system. Wrap the valve body with a wet rag to prevent overheating during the brazing process. Overheating the valve will damage the valve seals. Unbrazed the sealing disk, cool the valve body and prepare the joint for connections of the main lines. Repeat for the liquid line valve body.

WARNING

Never remove a cap from an access port unless the valve is fully back-seated with its valve stem in the maximum counter-clockwise position because the refrigerant charge will be lost. Always use a refrigeration valve wrench to open and close these service valves.

Connect the main liquid line to the liquid line connection on the condenser unit, while maintaining a flow of Nitrogen. Cool the valve body and replace the Schrader valve stem on the service port of the liquid line service valve.

Install the liquid line from the condenser unit to the evaporator liquid connection, maintaining a flow of nitrogen during all brazing operations.

The filter-drier and sight glass must be located in this line, close to the evaporator, leaving the O.D. unit.

Connect a low-pressure nitrogen source to the Schrader valve located on the evaporator section coil headers. Punch a small hole in the sealing disks, the flow of Nitrogen will prevent any debris from entering the system. Unbrazed both liquid and suction sealing disks and prepare the joints for connections of the main lines.

Connect the main liquid line to the liquid line connection on the evaporator section, while maintaining a flow of Nitrogen.

Make the suction line connection at the evaporator and run the line to the condenser unit. Connect the main suction line to the suction line connection on the condenser unit, while maintaining a flow of nitrogen. Cool the valve body and replace the Schrader valve stem on the service port of the liquid line service valve.

Once the brazing process is complete, leak testing should be done on all interconnecting piping and the evaporator before proper evacuation to 500 microns is performed. Once the line set and evaporator section is properly evacuated the service valves can be opened and the condensing unit is now ready to charge with the appropriate weight of refrigerant.

CAUTION

This system uses R-410A Refrigerant which operates at higher pressures than R-22. No other refrigerant may be used in this system. Gage sets, hoses, refrigerant containers and recovery systems must be designed to handle R-410A. If you are unsure, consult the equipment manufacturer. Failure to use R-410A compatible servicing equipment may result in property damage or injury.

WARNING

Wear safety glasses and gloves when handling refrigerants. Failure to follow this warning can cause serious personal injury.

NOTE: This instruction covers the installation and operation of the basic air handling unit. For refrigerant piping installation instructions refer to document 247077 "Application Data - General Piping Recommendations for Split System Air Conditioning and Heat Pumps".

Expansion Valve Bulb Installation

Thermal expansion valve bulbs are not factory-installed in their final locations. They are only temporarily secured for shipment. Thermal expansion valve bulbs are equipped with 60" capillary tubes to allow placement of the bulbs anywhere along the suction line; even outside the unit. Do not attempt to install the TXV bulb(s) until all other piping connections are complete.

NH-07 thru -20 Models

After all piping connections are made, the expansion valve bulbs may be mounted outside the unit by pulling them through the slotted bushing located on the patch plate and placed on the common suction line (See Figure 6). First, remove the bushing and slide the capillary tubes through the slot toward the center of the bushing. Reinsert the bushing, then fasten both bulbs in the 4 o'clock and/or 8 o'clock position using the bulb clamps provided. Insulate the bulbs to ensure proper valve operation.

NJ-10 thru -20 Models

After all piping connections are made, fasten the expansion valve bulb from System 1 to the corresponding suction line in a 4 o'clock or 8 o'clock position using one of the bulb clamps provided. Repeat the procedure for System 2. Expansion valve bulbs may be mounted outside the unit by pulling them through the slotted bushing located on the patch plate and placed on the matching system suction line. Insulate the bulbs to ensure proper valve operation.

WARNING

Ensure the TXV bulbs are not crossed between systems. Undesirable performance and possible compressor damage may occur.

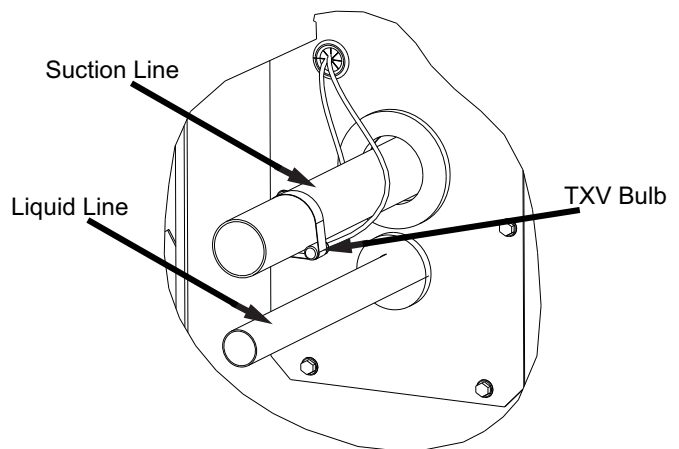

Figure 7: TVX Bulb Location

Liquid Line Solenoids

The NH-10 thru -20 units are shipped with factory installed, normally closed, liquid line solenoid valves on the second stage

system. When the solenoid coil is energized with a 24-volt signal, the valve will open.

During brazing operations, the valves should be placed in the OPEN position by removing the stem cap with a 9/16" wrench, then rotating the exposed valve stem inward (CLOCKWISE), approximately 10-12 full turns (from the fully CLOSED position), using a 4" adjustable wrench.

The valve stems should be returned to the CLOSED (COUNTER-CLOCKWISE) position prior to the unit's operation.

Air System Adjustment

Refer to Tables 7 thru 17 to adjust the air system.

Electrical Connections

The electric box ships complete with contractor, transformer, relays, circuit breaker and terminal block for making field connections.

Refer to Typical Unit Wiring Diagrams.

Install a power supply to meet the electrical requirements listed in Table 5.

Provide a disconnect switch and fusing as required.

Install interconnecting control wiring between condensing section, evaporator system and room thermostat.

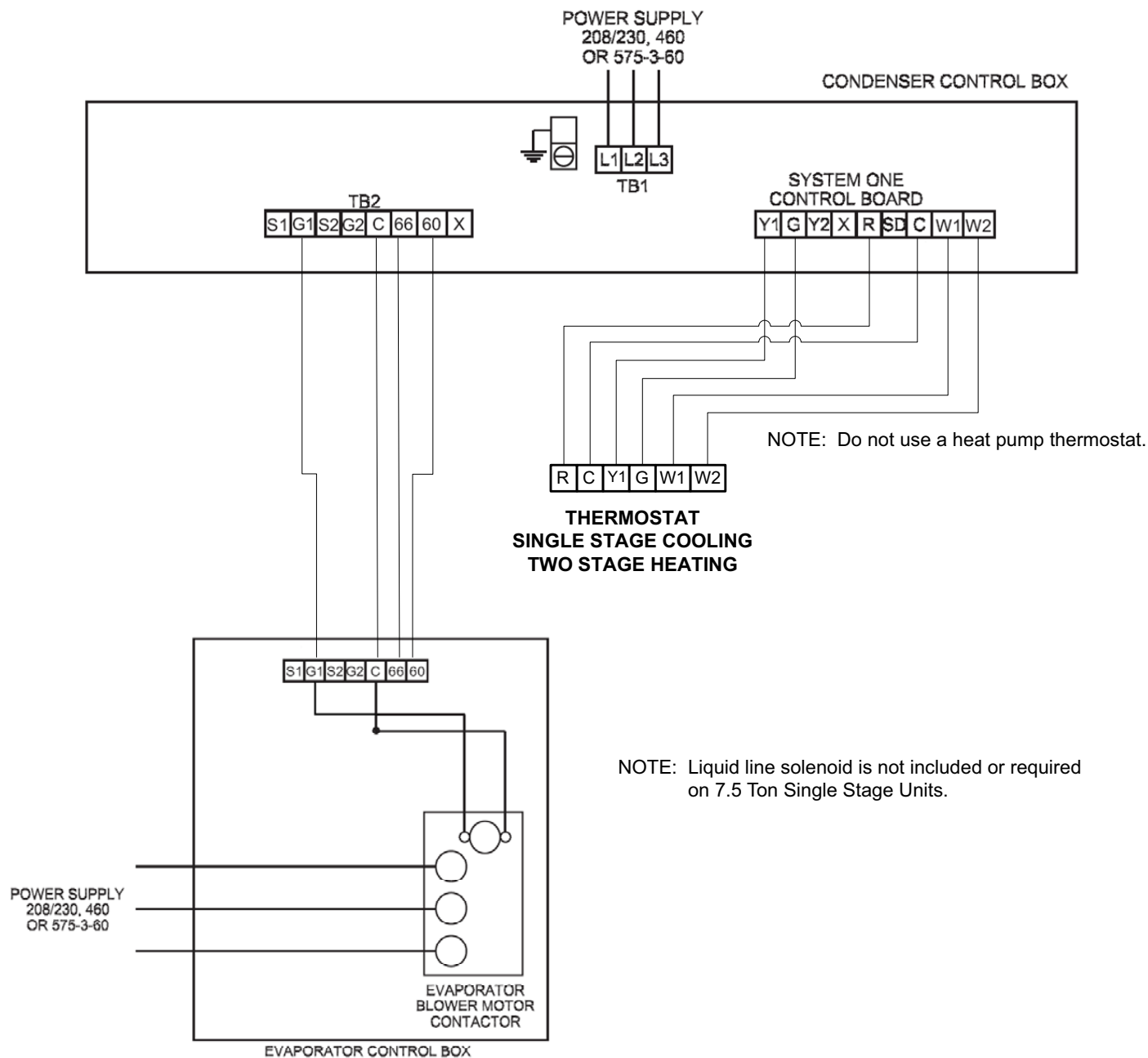

Figure 8: Typical Field Wiring Diagram - NH-07 Evaporator Unit with PH-07 Heat Pump

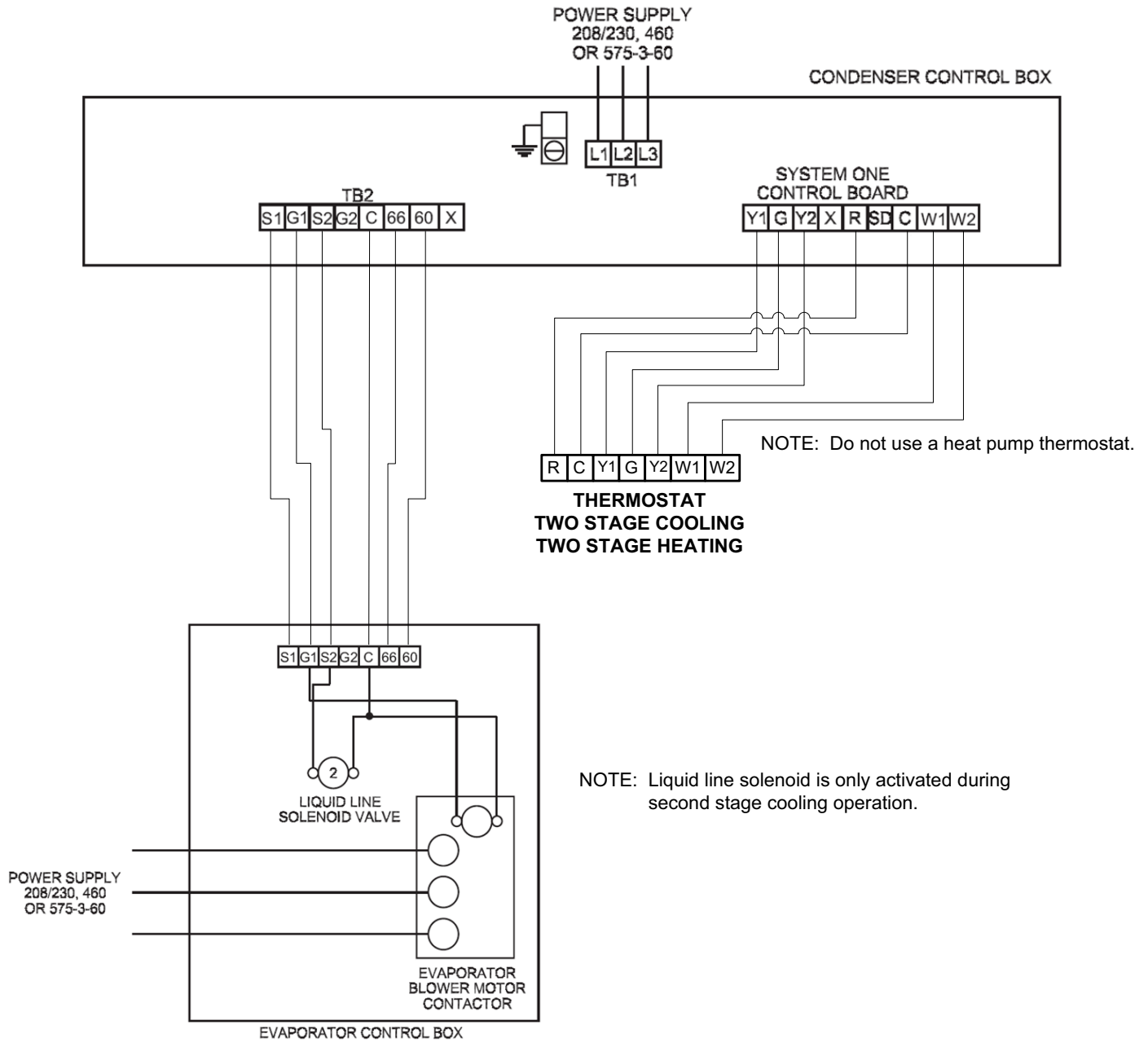

Figure 9: Typical Field Wiring Diagram - NH-10 thru -20 Evaporator Unit with PH-10 thru -20 Heat Pump

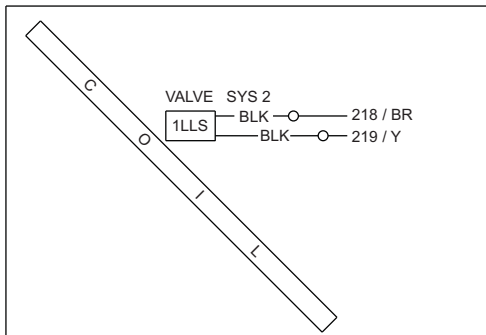

Figure 10: NH-10 thru -20 Liquid Line Solenoid Wiring

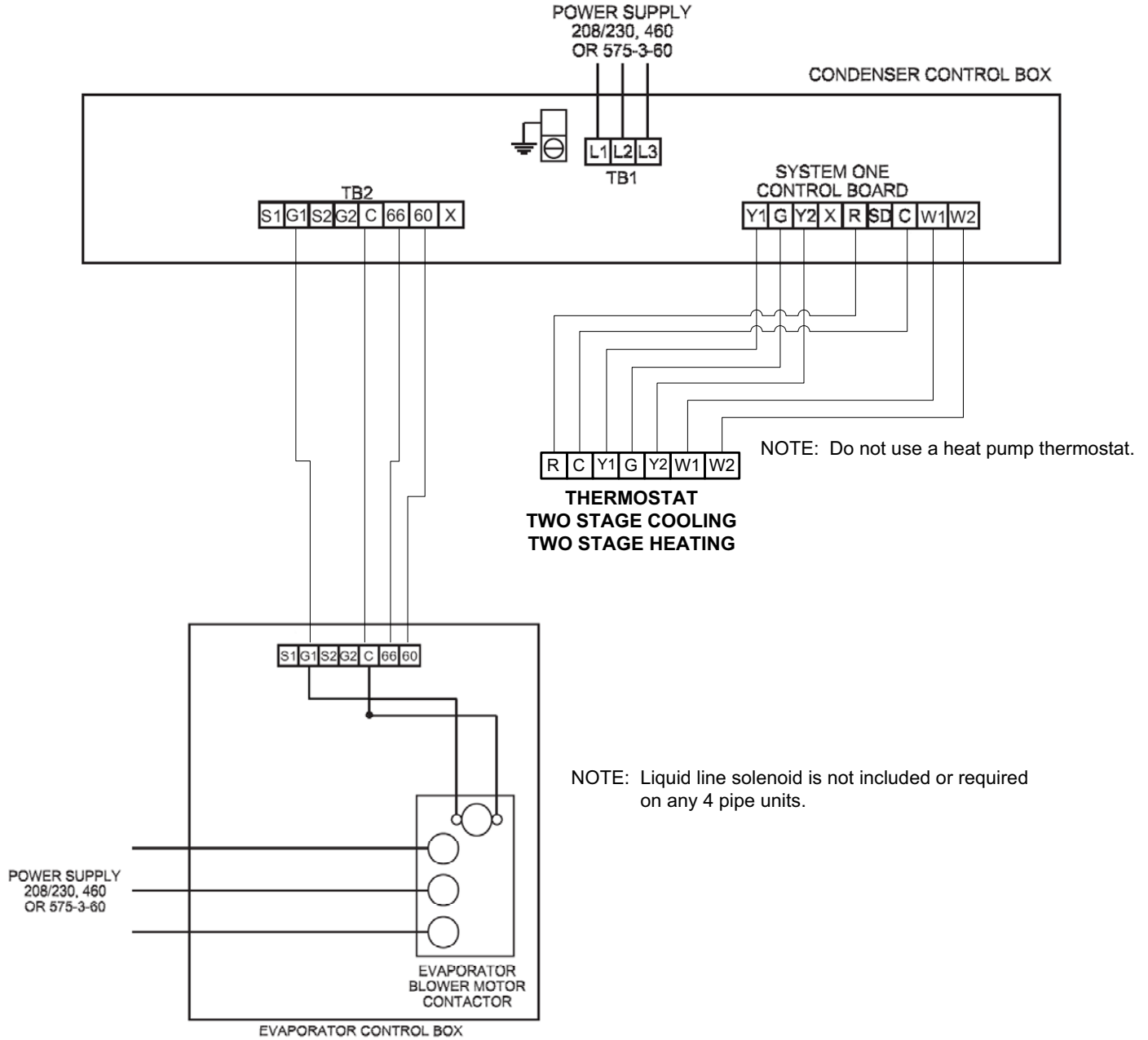

Figure 11: Typical Field Wiring Diagram - NJ-15 thru -20 Evaporator Unit with PJ-15 thru -20 Heat Pump

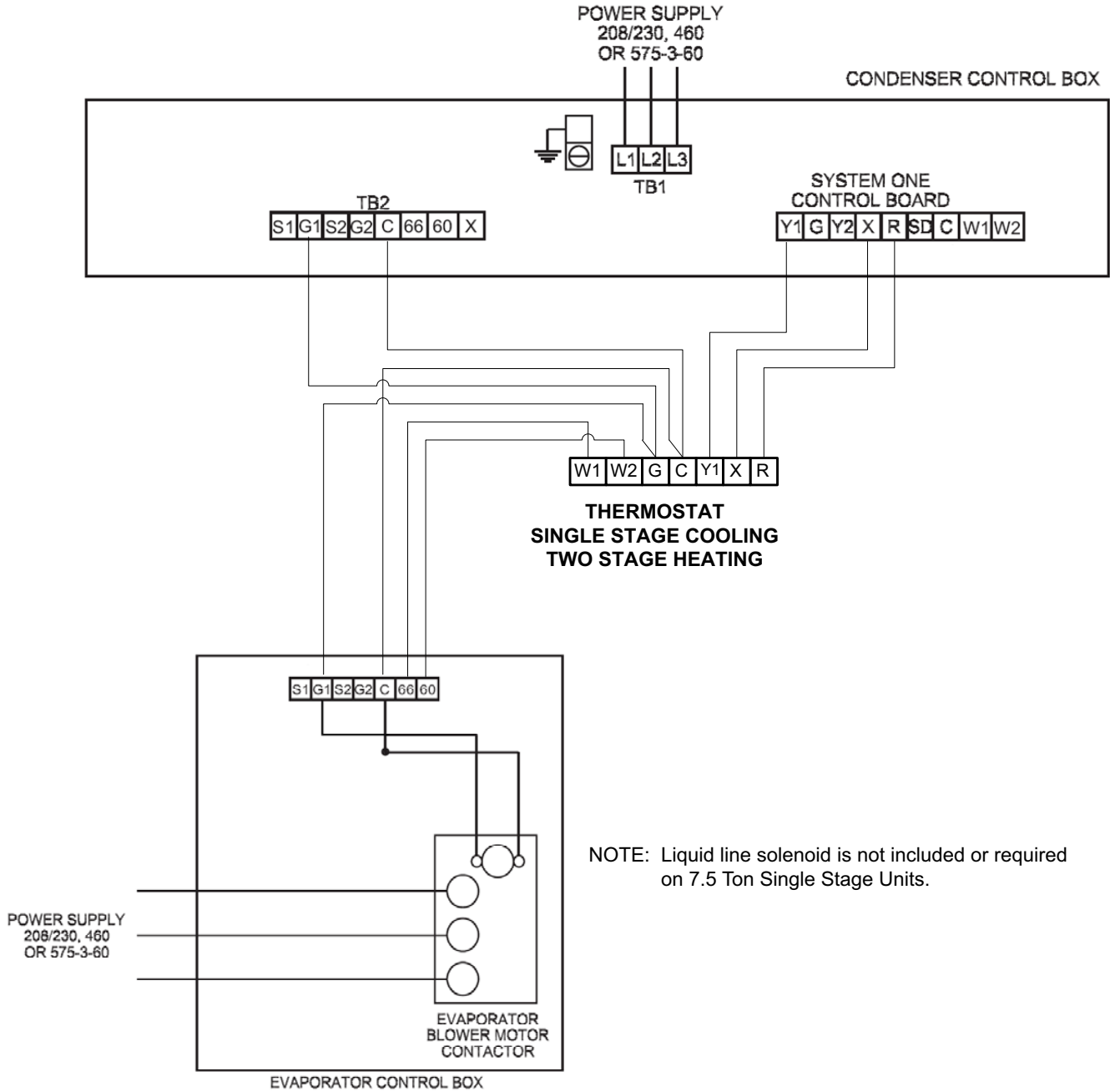

Figure 12: Typical Field Wiring Diagram - NH-07 Evaporator Unit with YH-07 Condenser Unit

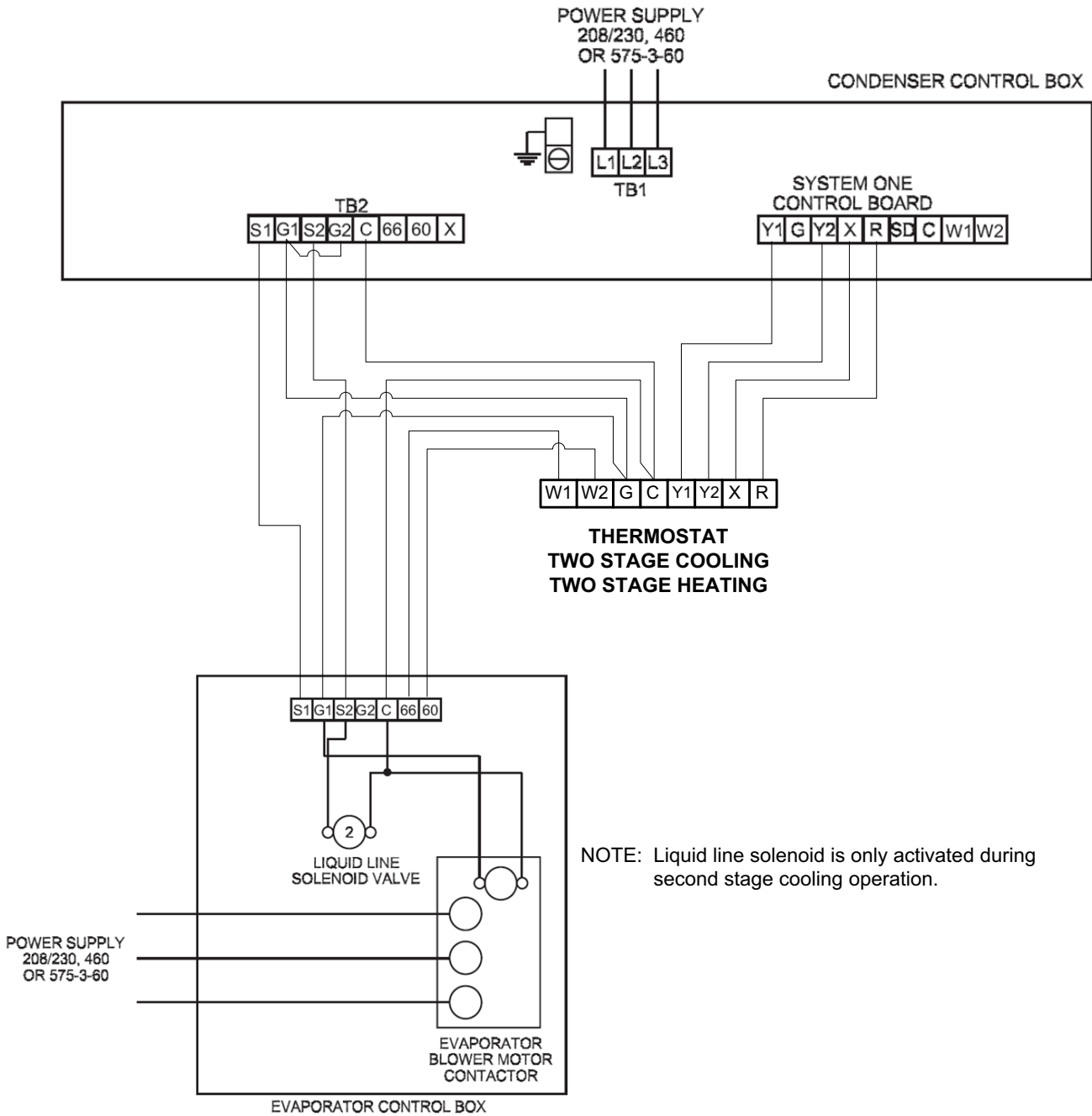

Figure 13: Typical Field Wiring Diagram - NH-10 thru -20 Evaporator Unit with YH-10 thru -20 Condenser Unit

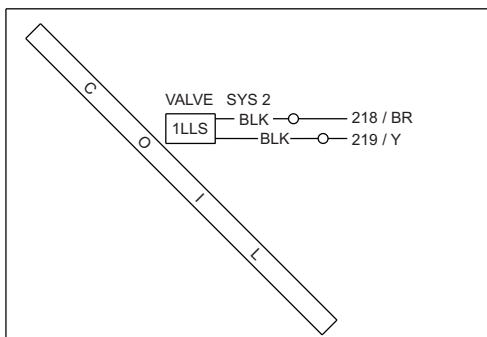

Figure 14: NH-10 thru -20 Liquid Line Solenoid Wiring

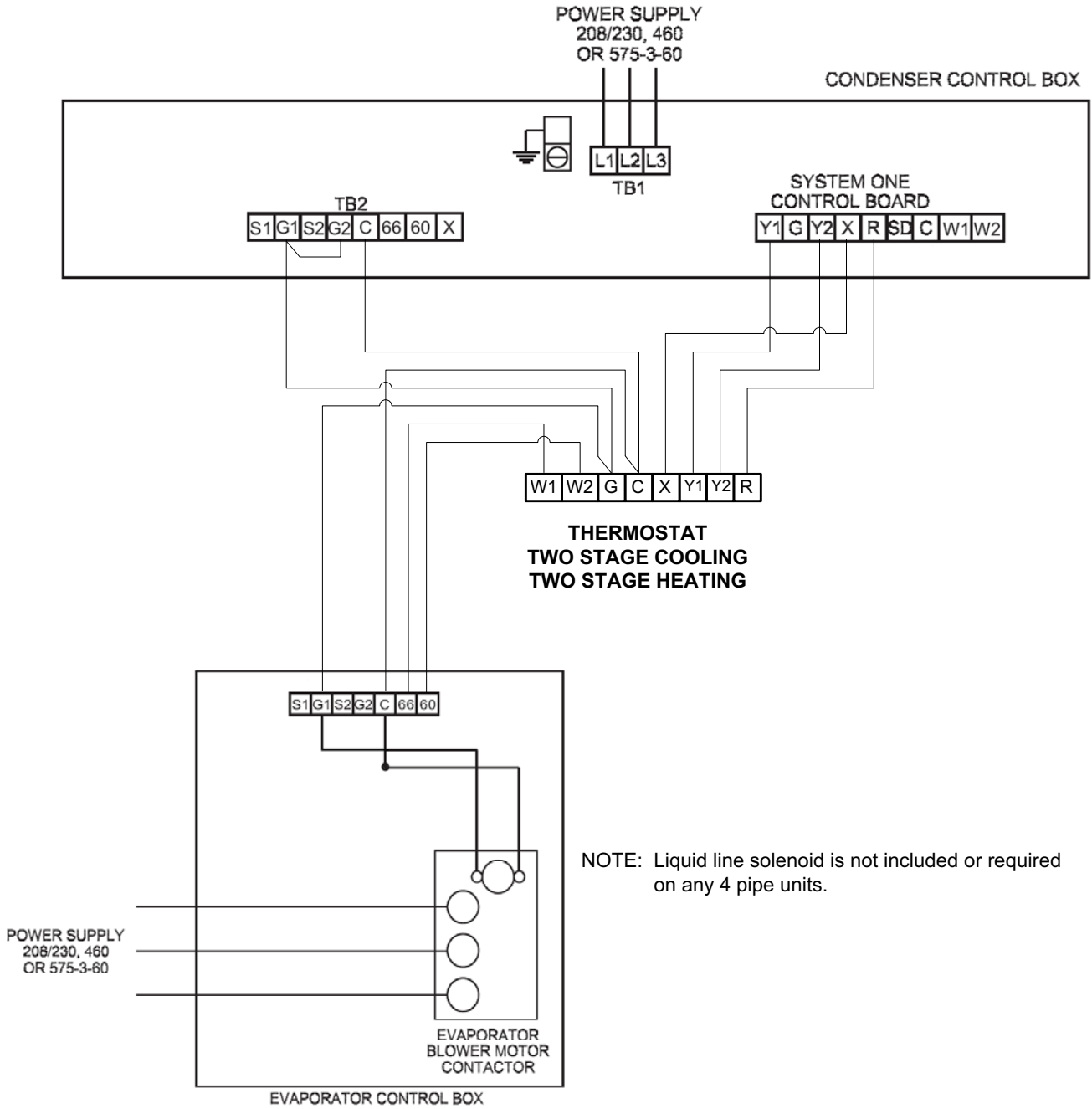

Figure 15: Typical Field Wiring Diagram - NJ-10 thru -20 Evaporator Unit with YJ-10 thru -20 Condenser Unit

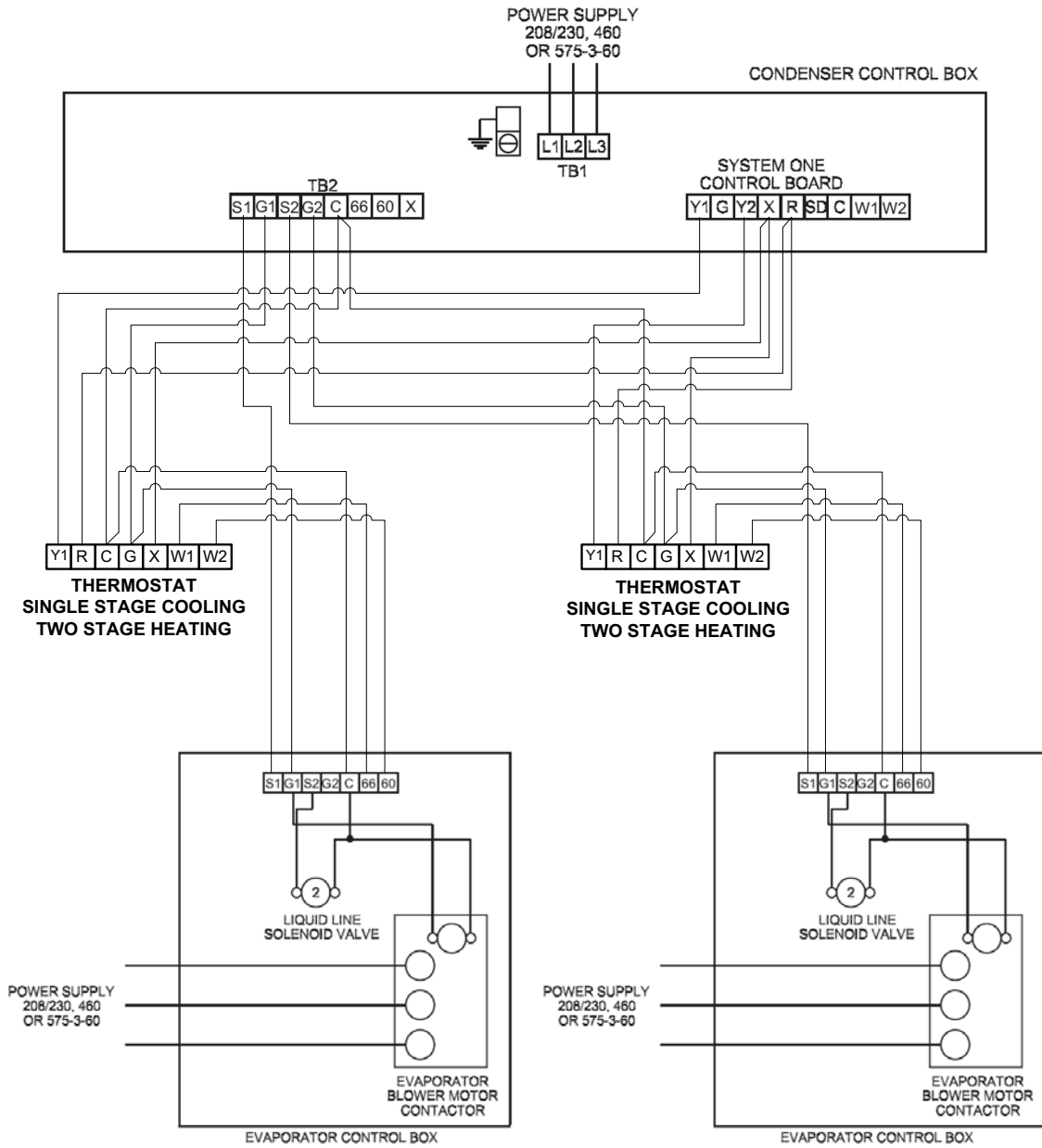

Figure 16: Typical Field Wiring Diagram - Twin NH-10 thru -20 Evaporator Units with 4-Pipe Condenser Unit

NOTE: Refer to Evaporator unit wiring diagram for control of liquid line solenoid valve.

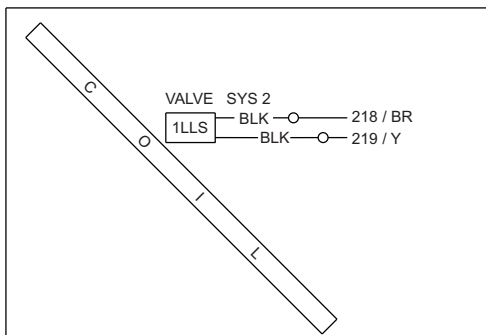

Figure 17: NH-10 thru -20 Liquid Line Solenoid Wiring

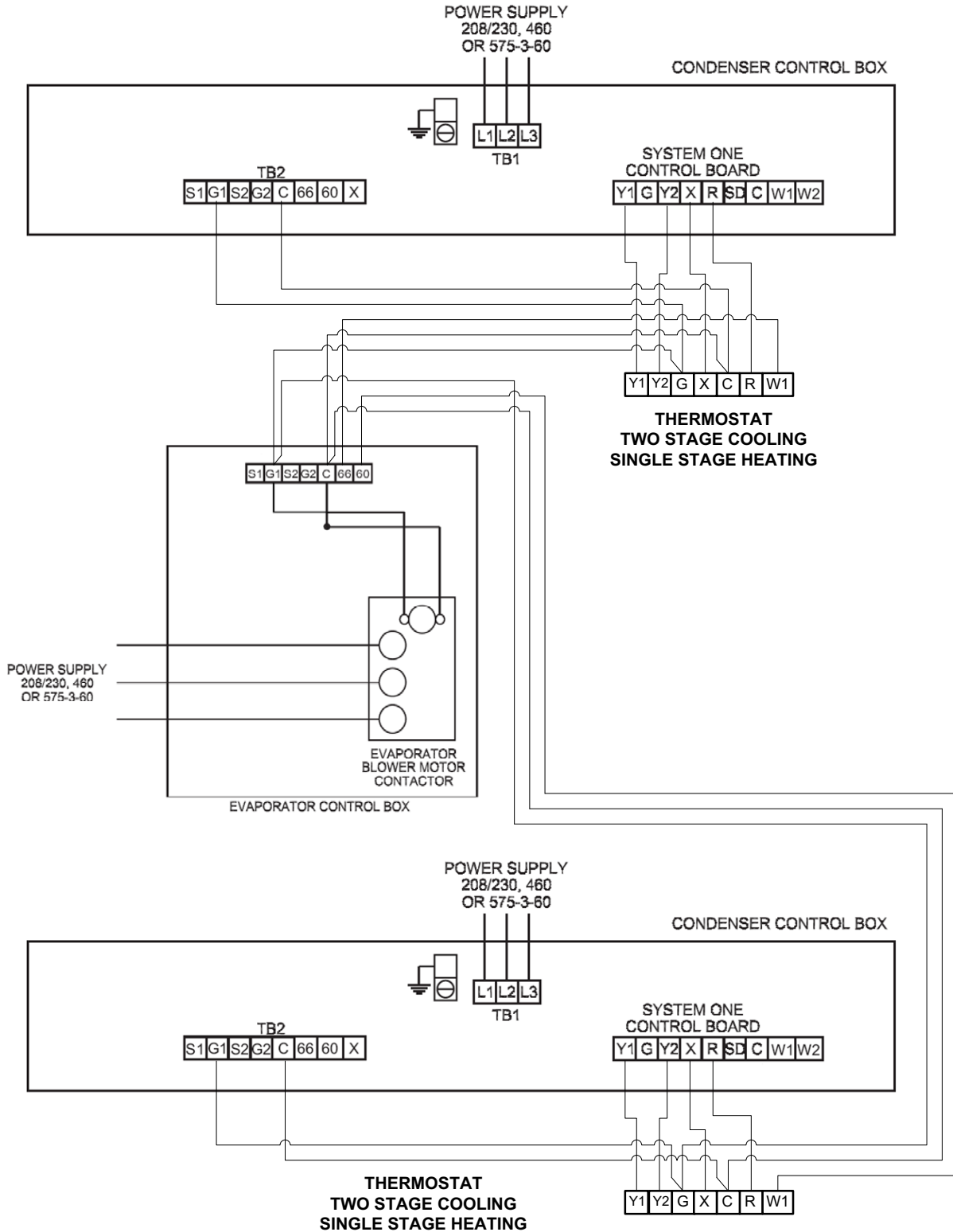

Figure 18: Typical Field Wiring Diagram - Single 4-Pipe Evaporator Unit with Twin Condenser Units

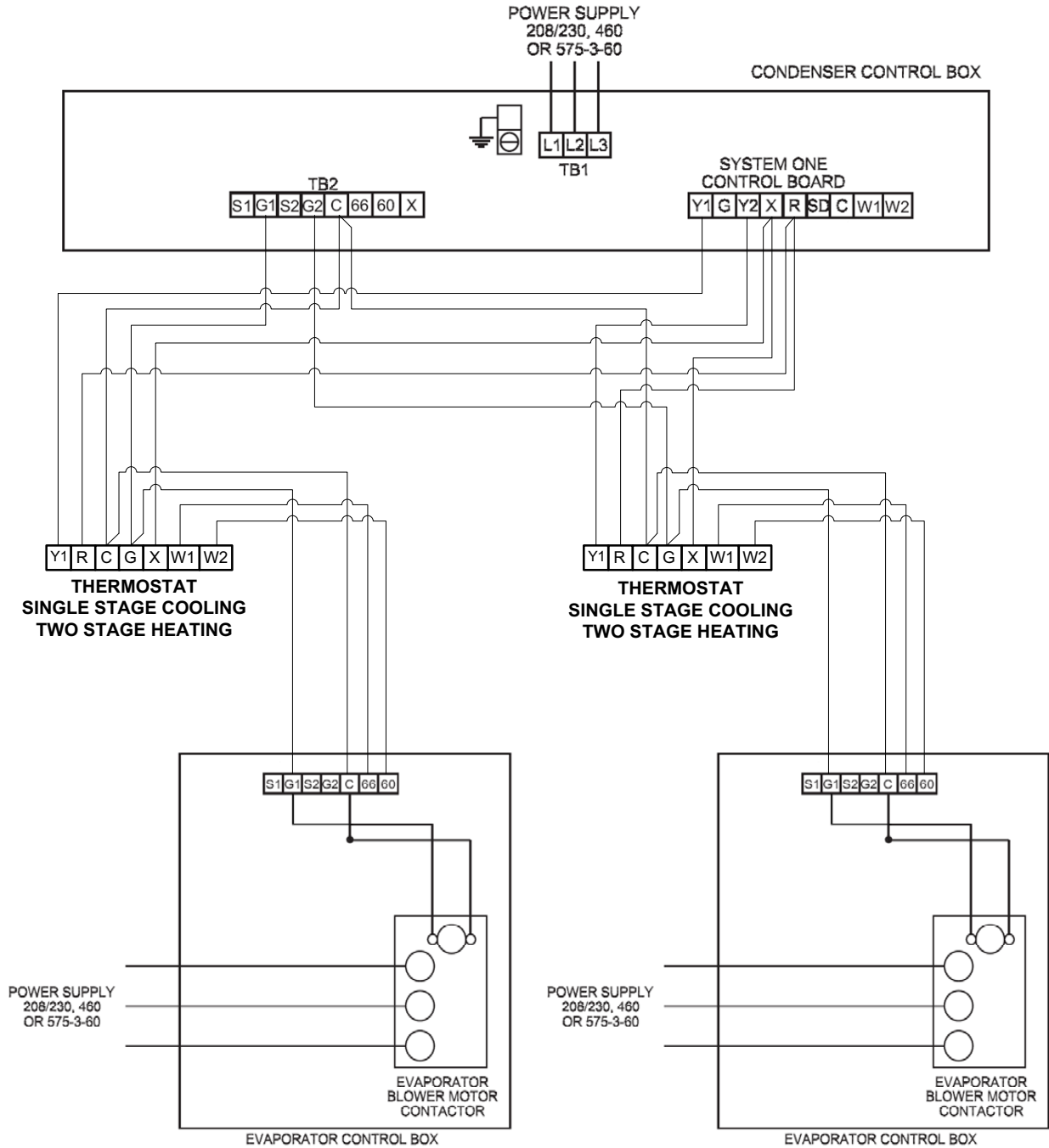

Figure 19: Typical Field Wiring Diagram - Twin NH-07 Evaporator Units with 4-Pipe Condenser Unit

Electrical Data

Table 5: Electrical Data - Evaporator Units

Motor HP	Power Supply	Supply Blower Motor	Electric Heat Option				MCA ¹ (Amps)	Max Fuse ² / Breaker ³ Size (Amps)
			FLA	Model	KW	Stages		
NH-07C00B								
1.5	208-3-60	5.0	None	---	---	---	6.3	15
			10 KW	7.5	1	20.8	32.3	35
			16 KW	12	2	33.4	47.9	50
			26 KW	19.5	2	54.2	73.9	80
			36 KW	27	2	75.1	99.9	100
	230-3-60	5.2	None	---	---	---	6.5	15
			10 KW	10	1	24.1	36.6	40
			16 KW	16	2	38.5	54.6	60
			26 KW	26	2	62.5	84.7	90
			36 KW	36	2	86.6	114.8	125
	460-3-60	2.5	None	---	---	---	3.1	15
			10 KW	10	1	12.0	18.2	20
			16 KW	16	2	19.2	27.2	30
			26 KW	26	2	31.3	42.2	45
			36 KW	36	2	43.3	57.3	60
	575-3-60	2.0	None	---	---	---	2.5	15
			10 KW	10	1	9.6	14.5	15
			16 KW	16	2	15.4	21.7	25
			26 KW	26	2	25.0	33.8	35
			36 KW	36	2	34.6	45.8	50
NH-07C00C, NH/NJ-10C00C								
2.0	208-3-60	6.6	None	---	---	---	8.3	15
			10 KW	7.5	1	20.8	34.3	35
			16 KW	12	2	33.4	49.9	50
			26 KW	19.5	2	54.2	75.9	80
			36 KW	27	2	75.1	101.9	110
	230-3-60	6.8	None	---	---	---	8.5	15
			10 KW	10	1	24.1	38.6	40
			16 KW	16	2	38.5	56.6	60
			26 KW	26	2	62.5	86.7	90
			36 KW	36	2	86.6	116.8	125
	460-3-60	3.4	None	---	---	---	4.3	15
			10 KW	10	1	12.0	19.3	20
			16 KW	16	2	19.2	28.3	30
			26 KW	26	2	31.3	43.3	45
			36 KW	36	2	43.3	58.4	60
	575-3-60	2.4	None	---	---	---	3.0	15
			10 KW	10	1	9.6	15.0	15
			16 KW	16	2	15.4	22.2	25
			26 KW	26	2	25.0	34.3	35
			36 KW	36	2	34.6	46.3	50

Table 5: Electrical Data - Evaporator Units (Continued)

Motor HP	Power Supply	Supply Blower Motor	Electric Heat Option				MCA ¹ (Amps)	Max Fuse ² / Breaker ³ Size (Amps)
			FLA	Model	KW	Stages		
NH/NJ-10C00D, NH/NJ-15C00D								
3.0	208-3-60	9.6	None	---	---	---	12.0	15
			10 KW	7.5	1	20.8	38.0	40
			16 KW	12	2	33.4	53.6	60
			26 KW	19.5	2	54.2	79.7	80
			36 KW	27	2	75.1	105.7	110
			50 KW ⁴	37.6	2	104.2	142.5	150
	230-3-60	9.4	None	---	---	---	11.8	15
			10 KW	10	1	24.1	41.8	45
			16 KW	16	2	38.5	59.9	60
			26 KW	26	2	62.5	89.9	90
			36 KW	36	2	86.6	120.0	125
			50 KW ⁴	50	2	120.3	132.0	150
	460-3-60	4.7	None	---	---	---	5.9	15
			10 KW	10	1	12.0	20.9	25
			16 KW	16	2	19.2	29.9	30
			26 KW	26	2	31.3	45.0	45
			36 KW	36	2	43.3	60.0	60
			50 KW ⁴	50	2	60.1	66.0	70
	575-3-60	3.6	None	---	---	---	4.5	15
			10 KW	10	1	9.6	16.5	20
16 KW			16	2	15.4	23.7	25	
26 KW			26	2	25.0	35.8	40	
36 KW			36	2	34.6	47.8	50	
50 KW ⁴			50	2	48.1	52.6	60	
NH/NJ-15C00E								
5.0	208-3-60	14.0	None	---	---	---	17.5	20
			10 KW	7.5	1	20.8	43.5	45
			16 KW	12	2	33.4	59.1	60
			26 KW	19.5	2	54.2	85.2	90
			36 KW	27	2	75.1	111.2	125
			50 KW	37.6	2	104.2	148.0	150
	230-3-60	14.0	None	---	---	---	17.5	20
			10 KW	10	1	24.1	47.6	50
			16 KW	16	2	38.5	65.6	70
			26 KW	26	2	62.5	95.7	100
			36 KW	36	2	86.6	125.8	150
			50 KW	50	2	120.3	137.8	150
	460-3-60	7.0	None	---	---	---	8.8	15
			10 KW	10	1	12.0	23.8	25
			16 KW	16	2	19.2	32.8	35
			26 KW	26	2	31.3	47.8	50
			36 KW	36	2	43.3	62.9	70
			50 KW	50	2	60.1	68.9	70
	575-3-60	5.2	None	---	---	---	6.5	15
			10 KW	10	1	9.6	18.5	20
16 KW			16	2	15.4	25.7	30	
26 KW			26	2	25.0	37.8	40	
36 KW			36	2	34.6	49.8	50	
50 KW			50	2	48.1	54.6	60	

Table 5: Electrical Data - Evaporator Units (Continued)

Motor HP	Power Supply	Supply Blower Motor	Electric Heat Option				MCA ¹ (Amps)	Max Fuse ² / Breaker ³ Size (Amps)
		FLA	Model	KW	Stages	Amps		
NH/NJ-20C00E								
5.0	208-3-60	14.0	None	---	---	---	17.5	20
			20 KW	15	1	41.7	69.5	70
			32 KW	24	2	66.7	100.8	110
			52 KW	39.1	2	108.4	153.2	175
	230-3-60	14.0	None	--	---	---	17.5	20
			20 KW	20	1	48.1	77.6	80
			32 KW	32	2	77.0	113.7	125
			52 KW	52	2	125.1	142.6	150
	460-3-60	7.0	None	---	---	---	8.8	15
			20 KW	20	1	24.1	38.8	40
			32 KW	32	2	38.5	56.9	60
			52 KW	52	2	62.5	71.3	80
	575-3-60	5.2	None	---	---	---	6.5	15
			20 KW	20	1	19.2	30.6	35
			32 KW	32	2	30.8	45.0	45
			52 KW	52	2	50.0	56.5	60
NH/NJ-20C00F								
7.5 ⁵	208-3-60	21.7	None	---	---	---	27.1	30
			20 KW	15	1	41.7	79.2	80
			32 KW	24	2	66.7	110.4	125
			52 KW	39.1	2	108.4	162.8	175
	230-3-60	20.0	None	--	---	---	25.0	25
			20 KW	20	1	48.1	85.1	90
			32 KW	32	2	77.0	121.2	125
			52 KW	52	2	125.1	150.1	175
	460-3-60	10.0	None	---	---	---	12.5	15
			20 KW	20	1	24.1	42.6	45
			32 KW	32	2	38.5	60.6	70
			52 KW	52	2	62.5	75.0	80
	575-3-60	7.8	None	---	---	---	9.8	15
			20 KW	20	1	19.2	33.8	35
			32 KW	32	2	30.8	48.2	50
			52 KW	52	2	50.0	59.8	60

1. Minimum Circuit Ampacity.
2. Dual Element, Time Delay Type.
3. HACR type per NEC.
4. (NC/ND)180C00D Models Only
5. NH/NJ-20C00F Motor Require Overload Relay

CFM Static Pressure and Power-Altitude and Temperature Corrections

The information below should be used to assist in application of product when being applied at altitudes at or exceeding 1000 feet above sea level.

The air flow rates listed in the standard blower performance tables are based on standard air at sea level. As the altitude or temperature increases, the density of air decreases. In order to use the indoor blower tables for high altitude applications, certain corrections are necessary.

A centrifugal fan is a "constant volume" device. This means that, if the rpm remains constant, the CFM delivered is the same regardless of the density of the air. However, since the air at high altitude is less dense, less static pressure will be generated and less power will be required than a similar application at sea level. Air density correction factors are shown in Table 6 and Figure 20.

Table 6: Altitude/Temperature Correction Factors

Air Temp.	Altitude (Ft.)										
	0	1000	2000	3000	4000	5000	6000	7000	8000	9000	10000
40	1.060	1.022	0.986	0.950	0.916	0.882	0.849	0.818	0.788	0.758	0.729
50	1.039	1.002	0.966	0.931	0.898	0.864	0.832	0.802	0.772	0.743	0.715
60	1.019	0.982	0.948	0.913	0.880	0.848	0.816	0.787	0.757	0.729	0.701
70	1.000	0.964	0.930	0.896	0.864	0.832	0.801	0.772	0.743	0.715	0.688
80	0.982	0.947	0.913	0.880	0.848	0.817	0.787	0.758	0.730	0.702	0.676
90	0.964	0.929	0.897	0.864	0.833	0.802	0.772	0.744	0.716	0.689	0.663
100	0.946	0.912	0.880	0.848	0.817	0.787	0.758	0.730	0.703	0.676	0.651

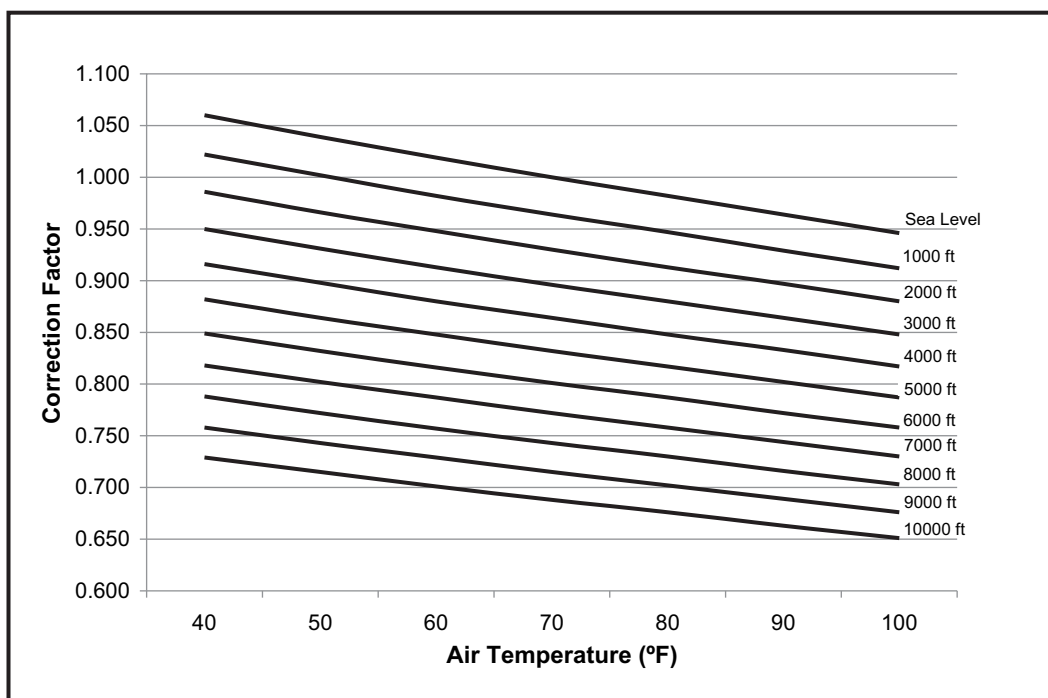
**Figure 20: Altitude/Temperature Correction Factors**

The examples below will assist in determining the airflow performance of the product at altitude.

Example 1: What are the corrected CFM, static pressure, and BHP at an elevation of 5,000 ft. if the blower performance data is 6,000 CFM, 1.5 IWC and 4.0 BHP?

Solution: At an elevation of 5,000 ft. the indoor blower will still deliver 6,000 CFM if the rpm is unchanged. However, the Altitude/Temperature Correction Factors table must be used to determine the static pressure and BHP. Since no temperature data is given, we will assume an air temperature of 70°F. The table shows the correction factor to be 0.832.

$$\text{Corrected static pressure} = 1.5 \times 0.832 = 1.248 \text{ IWC}$$

$$\text{Corrected BHP} = 4.0 \times 0.832 = 3.328$$

Example 2: A system, located at 5,000 feet of elevation, is to deliver 6,000 CFM at a static pressure of 1.5". Use the unit

blower tables to select the blower speed and the BHP requirement.

Solution: As in the example above, no temperature information is given so 70°F is assumed.

The 1.5" static pressure given is at an elevation of 5,000 ft. The first step is to convert this static pressure to equivalent sea level conditions.

$$\text{Sea level static pressure} = 1.5 / .832 = 1.80"$$

Enter the blower table at 6000 sCFM and static pressure of 1.8". The rpm listed will be the same rpm needed at 5,000 ft.

Suppose that the corresponding BHP listed in the table is 3.2. This value must be corrected for elevation.

$$\text{BHP at 5,000 ft.} = 3.2 \times .832 = 2.66$$

Drive Selection

1. Determine Upflow or Horizontal supply duct Application.
2. Determine desired airflow.
3. Calculate or measure the amount of external static pressure.
4. Using the operating point, determined from steps 1, 2 & 3, locate this point on the appropriate supply air blower performance table. (Linear interpolation may be necessary.)
5. Noting the RPM and BHP from step 4, locate the appropriate motor and/or drive on the RPM selection table.
6. Review the BHP compared to the motor options available. Select the appropriate motor and, or drive.
7. Review the RPM range for the motor options available. Select the appropriate drive if multiple drives are available for the chosen motor.
8. Determine turns open to obtain the desired operation point.

Example

1. 3250 CFM
2. 1.4 iwg
3. Using the supply air blower performance table below, the following data point was located: 1100 RPM & 1.8 BHP.
4. Using the RPM selection table below, Model X is found.
5. 1.8 BHP exceeds the maximum continuous BHP rating of the 1.5 HP motor. The 2 HP motor is required.
6. 1100 RPM is within the range of the 2 HP drives.
7. Using the 2 HP motor and drive, 1 turn open will achieve 1128 RPM.

Airflow Performance

Example Supply Air Blower Performance

(CFM)	Available External Static Pressure - IWG																			
	0.2		0.4		0.6		0.8		1.0		1.2		1.4		1.6		1.8		2.0	
	RPM	BHP	RPM	BHP	RPM	BHP	RPM	BHP	RPM	BHP	RPM	BHP	RPM	BHP	RPM	BHP	RPM	BHP	RPM	BHP
	Standard 1.5 HP & Drive										High Static 2 HP & Drive									
3000	696	0.9	757	1.1	822	1.2	891	1.3	961	1.3	1019	1.5	1077	1.6	1135	1.8				
3250	729	1.1	790	1.3	855	1.4	924	1.5	984	1.6	1042	1.7	1100	1.8	1159	2.0				
3500	766	1.3	826	1.5	892	1.6	953	1.6	1010	1.8	1069	1.9	1127	2.0						

RPM Selection

Unit Model	HP	Max BHP	Motor Sheave	Blower Sheave	6 Turns Open	5 Turns Open	4 Turns Open	3 Turns Open	2 Turns Open	1 Turn Open	Fully Closed	
X	Std.	1.5	1.73	1VL40	AK69	N/A	690	743	796	849	902	955
	HS	2	2.30	1VL40	AK56	N/A	863	929	995	1062	1128	1194

Airflow Performance

Table 7: NH-07 Upflow

(CFM)	Available External Static Pressure - IWG																			
	0.2		0.4		0.6		0.8		1.0		1.2		1.4		1.6		1.8		2.0	
	RPM	BHP	RPM	BHP	RPM	BHP	RPM	BHP	RPM	BHP	RPM	BHP	RPM	BHP	RPM	BHP	RPM	BHP	RPM	BHP
	Std. 1.5 HP & Field Supplied Drive				Standard 1.5 HP & Drive						High Static 2 HP & Drive									
2250					754	0.8	828	0.9	902	1.0	988	1.1	1051	1.3	1116	1.4	1183	1.5		
2500			707	0.8	777	0.9	851	1.0	925	1.1	996	1.3	1059	1.4	1124	1.5	1191	1.7		
2750			735	0.9	805	1.1	879	1.2	953	1.3	1012	1.4	1076	1.6	1141	1.7				
3000	705	1.0	767	1.1	837	1.2	911	1.3	973	1.5	1035	1.6	1099	1.7	1164	1.9				
3250	741	1.1	802	1.3	872	1.4	947	1.5	1002	1.7	1064	1.8	1127	2.0						
3500	780	1.4	842	1.5	912	1.6	974	1.8	1035	1.9	1097	2.1	1161	2.2						
3750	823	1.6	884	1.7	954	1.9	1012	2.0	1072	2.2	1134	2.3	Exceeds BHP Limitations							

1. Airflow performance includes dry evaporator coil. See Static Resistance table for additional applications.
2. See RPM Selection table to determine desired motor sheave setting and to determine the maximum continuous BHP.
3. kW = BHP x 0.746 ÷ nameplate rated motor efficiency.

Table 8: NH-07 Horizontal

(CFM)	Available External Static Pressure - IWG																			
	0.2		0.4		0.6		0.8		1.0		1.2		1.4		1.6		1.8		2.0	
	RPM	BHP	RPM	BHP	RPM	BHP	RPM	BHP	RPM	BHP	RPM	BHP	RPM	BHP	RPM	BHP	RPM	BHP	RPM	BHP
	Std. 1.5 HP & Field Supplied Drive				Standard 1.5 HP & Drive						High Static 2 HP & Drive									
2250					747	0.8	816	0.9	889	1.0	954	1.2	1013	1.3	1071	1.5	1128	1.6		
2500			703	0.8	768	0.9	837	1.0	909	1.1	977	1.2	1036	1.4	1094	1.5	1151	1.7		
2750			728	0.9	793	1.0	862	1.1	934	1.2	998	1.4	1056	1.5	1114	1.7				
3000	696	0.9	757	1.1	822	1.2	891	1.3	961	1.4	1019	1.6	1077	1.7	1135	1.9				
3250	729	1.1	790	1.3	855	1.4	924	1.5	984	1.6	1042	1.8	1100	1.9	1159	2.1				
3500	766	1.3	826	1.5	892	1.6	953	1.6	1010	1.9	1069	2.0	1127	2.2						
3750	806	1.6	867	1.7	932	1.8	984	1.9	1041	2.1	1099	2.3	Exceeds BHP Limitations							

1. Airflow performance includes dry evaporator coil. See Static Resistance table for additional applications.
2. See RPM Selection table to determine desired motor sheave setting and to determine the maximum continuous BHP.
3. kW = BHP x 0.746 ÷ nameplate rated motor efficiency.

Table 9: NH/NJ-10 Upflow

(CFM)	Available External Static Pressure - IWG																			
	0.2		0.4		0.6		0.8		1.0		1.2		1.4		1.6		1.8		2.0	
	RPM	BHP	RPM	BHP	RPM	BHP	RPM	BHP	RPM	BHP	RPM	BHP	RPM	BHP	RPM	BHP	RPM	BHP	RPM	BHP
	Std. 2 HP & Field Supplied Drive				Standard 2 HP & Drive								High Static 3 HP & Drive							
2500					671	0.8	728	0.9	788	1.0	853	1.1	926	1.3	975	1.5	1026	1.6	1077	1.7
2750					684	0.9	741	1.0	801	1.1	866	1.2	933	1.4	982	1.6	1032	1.7	1084	1.8
3000					701	1.0	757	1.1	817	1.3	882	1.4	941	1.5	991	1.7	1041	1.8	1092	2.0
3250			664	1.0	719	1.1	776	1.3	836	1.4	903	1.5	952	1.7	1002	1.8	1052	2.0		
3500			685	1.1	741	1.3	797	1.4	858	1.5	917	1.7	966	1.9	1015	2.0	1066	2.2		
3750	653	1.1	709	1.3	764	1.4	821	1.6	884	1.7	933	1.9	982	2.0	1031	2.2	1082	2.3		
4000	679	1.3	735	1.5	790	1.6	847	1.8	903	1.9	952	2.1	1001	2.3	1050	2.4				
4250	707	1.5	762	1.6	818	1.8	875	1.9	924	2.1	973	2.3	1022	2.5	1072	2.7				
4500	737	1.7	792	1.9	850	2.0	899	2.2	948	2.4	997	2.6	1046	2.8						
4750	768	1.9	824	2.1	877	2.2	926	2.5	975	2.7	1024	2.9	1073	3.0						
5000	801	2.1	856	2.3	906	2.5	956	2.8	1005	3.0	1053	3.2	High Static 3 HP & Field Supplied Drive							

1. Airflow performance includes dry evaporator coil. See Static Resistance table for additional applications.
2. See RPM Selection table to determine desired motor sheave setting and to determine the maximum continuous BHP.
3. kW = BHP x 0.746 ÷ nameplate rated motor efficiency.

Table 10: NH/NJ-10 Horizontal

(CFM)	Available External Static Pressure - IWG																			
	0.2		0.4		0.6		0.8		1.0		1.2		1.4		1.6		1.8		2.0	
	RPM	BHP	RPM	BHP	RPM	BHP	RPM	BHP	RPM	BHP	RPM	BHP	RPM	BHP	RPM	BHP	RPM	BHP	RPM	BHP
	Std. 2 HP & Field Supplied Drive				Standard 2 HP & Drive								High Static 3 HP & Drive							
2500					686	0.8	730	0.9	778	0.9	840	1.0	917	1.3	964	1.5	1011	1.6	1060	1.7
2750					698	0.9	742	1.0	790	1.0	852	1.1	924	1.4	971	1.6	1019	1.7	1067	1.9
3000					714	1.0	758	1.1	806	1.1	868	1.2	935	1.6	981	1.7	1029	1.9	1078	2.0
3250			684	1.0	734	1.2	778	1.2	826	1.3	902	1.6	948	1.7	995	1.9	1042	2.0		
3500			707	1.2	757	1.3	801	1.4	849	1.4	917	1.7	964	1.9	1010	2.0	1058	2.2		
3750	669	1.2	734	1.4	784	1.5	828	1.6	890	1.7	936	1.9	982	2.1	1029	2.2	1076	2.4		
4000	699	1.4	764	1.6	814	1.7	858	1.8	910	2.0	956	2.1	1002	2.3	1049	2.4				
4250	732	1.6	798	1.8	847	1.9	887	2.0	933	2.2	978	2.4	1025	2.5	1071	2.7				
4500	769	1.8	834	2.0	884	2.1	911	2.3	957	2.4	1003	2.6	1049	2.8						
4750	808	2.1	874	2.3	891	2.3	937	2.5	983	2.7	1029	2.9	1075	3.1						
5000	850	2.3	873	2.4	919	2.6	965	2.8	1011	3.0	1057	3.2	High Static 3 HP & Field Supplied Drive							

1. Airflow performance includes dry evaporator coil. See Static Resistance table for additional applications.
2. See RPM Selection table to determine desired motor sheave setting and to determine the maximum continuous BHP.
3. kW = BHP x 0.746 ÷ nameplate rated motor efficiency.

Table 11: NH/NJ-15 Upflow

(CFM)	Available External Static Pressure - IWG																	
	0.2		0.4		0.6		0.8		1.0		1.2		1.4		1.6		1.8	
	RPM	BHP	RPM	BHP	RPM	BHP	RPM	BHP	RPM	BHP	RPM	BHP	RPM	BHP	RPM	BHP	RPM	BHP
	Std. 3 HP & Field Supplied Drive				Standard 3 HP & Drive						High Static 5 HP & Drive							
4500					583	1.1	634	1.3	688	1.5	738	1.9	782	2.3	827	2.6		
4750					592	1.2	643	1.4	700	1.8	744	2.1	788	2.4	833	2.7		
5000					602	1.2	653	1.4	707	1.9	751	2.2	795	2.6	840	2.9		
5250					613	1.3	664	1.5	716	2.1	759	2.4	804	2.7	848	3.1		
5500			577	1.1	625	1.4	676	1.6	725	2.3	768	2.6	813	2.9	857	3.2		
5750			590	1.2	638	1.4	689	1.7	735	2.5	778	2.8	822	3.1				
6000			603	1.3	651	1.6	702	2.3	745	2.7	789	3.0	833	3.3				
6250			617	1.5	664	1.7	714	2.6	757	2.9	801	3.2	845	3.5				
6500	587	1.4	631	1.6	679	1.8	726	2.8	769	3.1	813	3.4	857	3.8				
6750	601	1.6	645	1.8	693	2.0	739	3.0	782	3.4	826	3.7						
7000	616	1.8	660	2.0	710	2.9	753	3.3	796	3.6	839	3.9						
7250	632	2.1	675	2.3	725	3.2	767	3.6	810	3.9	854	4.2						
7500	647	2.3	691	2.5	740	3.5	782	3.9	825	4.2	High Static 5 HP & Field Supplied Drive							

1. Airflow performance includes dry evaporator coil. See Static Resistance table for additional applications.
2. See RPM Selection table to determine desired motor sheave setting and to determine the maximum continuous BHP.
3. kW = BHP x 0.746 ÷ nameplate rated motor efficiency.

Table 12: NH/NJ-15 Horizontal

(CFM)	Available External Static Pressure - IWG																	
	0.2		0.4		0.6		0.8		1.0		1.2		1.4		1.6		1.8	
	RPM	BHP	RPM	BHP	RPM	BHP	RPM	BHP	RPM	BHP	RPM	BHP	RPM	BHP	RPM	BHP	RPM	BHP
	Std. 3 HP & Field Supplied Drive				Standard 3 HP & Drive						High Static 5 HP & Drive							
4500					585	1.5	634	1.6	687	1.8	735	2.0	780	2.5	827	2.7	875	2.9
4750					595	1.6	644	1.7	697	1.9	741	2.4	787	2.7	834	2.9		
5000					605	1.7	655	1.8	708	2.0	749	2.6	795	2.9	842	3.1		
5250					617	1.8	666	2.0	719	2.1	757	2.8	804	3.1	851	3.3		
5500			582	1.8	629	1.9	678	2.1	731	2.3	767	3.0	813	3.2	860	3.4		
5750			594	1.9	642	2.1	691	2.2	737	2.4	778	3.2	824	3.4	871	3.7		
6000			608	2.1	655	2.2	705	2.4	744	3.1	789	3.4	835	3.7				
6250			622	2.2	670	2.4	719	2.6	756	3.3	801	3.6	847	3.9				
6500	589	2.2	637	2.4	684	2.6	733	2.7	769	3.6	814	3.9	860	4.1				
6750	604	2.4	652	2.6	699	2.8	738	3.5	782	3.8	827	4.1	873	4.4				
7000	620	2.6	667	2.8	715	3.0	752	3.8	796	4.1	841	4.4						
7250	636	2.8	683	3.0	731	3.2	766	4.1	811	4.4	856	4.7						
7500	652	3.0	700	3.2	738	4.0	781	4.4	825	4.7	High Static 5 HP & Field Supplied Drive							

1. Airflow performance includes dry evaporator coil. See Static Resistance table for additional applications.
2. See RPM Selection table to determine desired motor sheave setting and to determine the maximum continuous BHP.
3. kW = BHP x 0.746 ÷ nameplate rated motor efficiency.

Table 15: RPM Selection

Unit Model	HP	Max BHP	Motor Sheave	Blower Sheave	6 Turns Open	5 Turns Open	4 Turns Open	3 Turns Open	2 Turns Open	1 Turn Open	Fully Closed	
NH-07	Std.	1.5	1.73	1VL40	AK69	-. ¹	690	743	796	849	902	955
	HS	2	2.30	1VL40	AK56	-. ¹	863	929	995	1062	1128	1194
NH/NJ-10	Std.	2	2.30	1VL40	AK74	-. ¹	641	690	739	789	838	887
	HS	3	3.45	1VP56	AK84	-. ¹	906	949	992	1035	1078	1121
NH/NJ-15	Std.	3	3.45	1VP50	AK114	-. ¹	565	596	627	659	690	721
	HS	5	5.75	2VP50	2B5V94	707	745	782	819	856	894	-. ²
NH/NJ-20	Std.	5	5.75	2VP50	2B5V94	686	722	758	794	830	866	-. ²
	HS	7.5	8.63	2VP65	2B5V94	925	960	996	1031	1067	1103	1138

1. Setting not available.

2. Setting not recommended for use with Type B v-belts.

Table 16: Additional Static Resistance

Model	CFM	Wet Indoor ¹ Coil	2" Filters	Bottom Return	Electric Heat kW				
					10	16	26	36	50
NH-07	2250	0.03	0.10	0.02	0.01	0.02	0.03	0.04	---
	2500	0.03	0.11	0.03	0.01	0.02	0.03	0.05	---
	2750	0.02	0.11	0.03	0.01	0.03	0.04	0.07	---
	3000	0.02	0.12	0.04	0.01	0.03	0.05	0.08	---
	3250	0.01	0.13	0.04	0.02	0.04	0.06	0.09	---
	3500	0.00	0.14	0.05	0.02	0.04	0.07	0.10	---
	3750	0.00	0.15	0.06	0.02	0.05	0.08	0.12	---
NH/NJ-10	3000	0.08	0.12	0.04	0.01	0.03	0.05	0.08	---
	3250	0.07	0.13	0.04	0.02	0.04	0.06	0.09	---
	3500	0.07	0.14	0.05	0.02	0.04	0.07	0.10	---
	3750	0.06	0.15	0.06	0.02	0.05	0.08	0.12	---
	4000	0.05	0.16	0.07	0.03	0.06	0.09	0.14	---
	4250	0.04	0.18	0.08	0.03	0.06	0.10	0.15	---
	4500	0.03	0.19	0.09	0.03	0.07	0.11	0.17	---
	4750	0.02	0.21	0.10	0.04	0.08	0.13	0.19	---
NH/NJ-15	5000	0.00	0.23	0.11	0.04	0.09	0.14	0.21	---
	4500	0.07	0.11	0.03	0.03	0.07	0.11	0.17	0.21
	4750	0.06	0.11	0.03	0.04	0.08	0.13	0.19	0.22
	5000	0.06	0.11	0.04	0.04	0.09	0.14	0.21	0.24
	5250	0.06	0.12	0.04	0.05	0.10	0.15	0.23	0.26
	5500	0.05	0.12	0.04	0.05	0.11	0.17	0.25	0.29
	5750	0.05	0.12	0.05	0.06	0.12	0.19	0.28	0.32
	6000	0.05	0.13	0.05	0.06	0.13	0.20	0.30	0.35
	6250	0.04	0.14	0.06	0.07	0.14	0.22	0.33	0.38
	6500	0.03	0.14	0.06	0.07	0.15	0.24	0.35	0.42
	6750	0.03	0.15	0.07	0.08	0.17	0.26	0.38	0.47
	7000	0.02	0.16	0.07	0.08	0.18	0.28	0.41	0.50
	7250	0.01	0.16	0.08	0.09	0.19	0.30	0.44	0.53
7500	0.00	0.17	0.08	0.10	0.20	0.32	0.47	0.56	

Model	CFM	Wet Indoor Coil	2" Filters	Bottom Return	Electric Heat kW		
					20	32	52
NH/NJ-20	6000	0.08	0.12	0.06	0.01	0.03	0.05
	6250	0.08	0.13	0.06	0.02	0.03	0.05
	6500	0.08	0.13	0.07	0.02	0.04	0.06
	6750	0.07	0.14	0.07	0.02	0.04	0.06
	7000	0.07	0.14	0.08	0.02	0.04	0.07
	7250	0.06	0.15	0.08	0.02	0.05	0.07
	7500	0.06	0.16	0.09	0.02	0.05	0.08
	7750	0.05	0.16	0.09	0.02	0.05	0.08
	8000	0.05	0.17	0.10	0.03	0.06	0.09
	8250	0.04	0.18	0.10	0.03	0.06	0.09
	8500	0.04	0.19	0.11	0.03	0.06	0.10
	8750	0.03	0.20	0.12	0.03	0.07	0.11
	9000	0.02	0.21	0.12	0.03	0.07	0.11
	9250	0.01	0.22	0.13	0.04	0.08	0.12
	9500	0.00	0.23	0.00	0.04	0.08	0.13
	9750	0.00	0.24	0.00	0.04	0.09	0.13
10000	0.00	0.25	0.00	0.04	0.09	0.14	

1. Pressure drop added by condensate over a dry coil.

Table 17: Blower Motor And Drive Data

Unit Model	Blower Motor Data					Drive Data								
	HP	RPM	SF	Frame Size	Model Number	Blower RPM Range	Adjustable Motor Sheave		Model Number	Fixed Blower Sheave		Belts		
							Pitch Diameter (in.)	Bore (in.)		Pitch Diameter (in.)	Bore (in.)	Qty.	Pitch Length (in.)	Designation
NH-07	Std. 1.5	1725	1.15	56	1VL40	690 - 955	2.6 - 3.6	0.875	AK69	6.5	1.000	1	42.3	A41
	HS 2			56HZ	1VL40	863 - 1194	2.6 - 3.6	0.875	AK56	5.2	1.000	1	40.3	A39
NH/NJ-10	Std. 2	1725	1.15	56HZ	1VL40	641 - 887	2.6 - 3.6	0.875	AK74	7.0	1.000	1	45.3	A44
	HS 3			56HZ	1VP56	906 - 1121	4.2 - 5.2	0.875	AK84	8.0	1.000	1	48.3	A47
NH/NJ-15	Std. 3	1725	1.15	56HZ	1VP50	565 - 721	3.6 - 4.6	0.875	AK114	11.0	1.000	1	45.3	A44
	HS 5			184T	2VP50	707 - 894	3.7 - 4.7	1.125	2B5V94	9.7	1.000	2	41.8	B40
NH/NJ-20	Std. 5	1725	1.15	184T	2VP50	686 - 866	3.7 - 4.7	1.125	2B5V94	9.7	1.188	2	41.8	B40
	HS 7.5			213T	2VP65	925 - 1138	5.2 - 6.4	1.375	2B5V94	9.7	1.188	2	46.8	B45

To check the supply air CFM after the initial balancing has been completed:

1. Drill two (2) 5/16-inch holes in the side panel as shown in Figure 24.
2. Insert at least 8 inches of 1/4 inch tubing into each of these holes for sufficient penetration into the airflow on both sides of the evaporator coil.
3. Using an inclined manometer, determine the pressure drop across a dry evaporator coil. Since the moisture on an evaporator coil may vary greatly, measuring the pressure drop across the wet coil under field conditions would be inaccurate. To assure a dry coil, the refrigerant system should be de-activated while the test is being run.
4. Knowing the pressure drop across a dry coil, the actual CFM through the unit can be determined from the curves shown in Figure 22.

If the CFM is above or below the specified value, the supply air motor pulley may have to be readjusted. After one hour of operation, check the belt and pulleys for tightness and alignment.



WARNING

Failure to properly adjust the total system air quantity can result in extensive blower damage.

After readings have been obtained, remove the tubes and seal up the drilled holes in the side panel. 5/16 inch dot plugs (P/N 029-12880) are available from your local Source 1 parts distribution center.

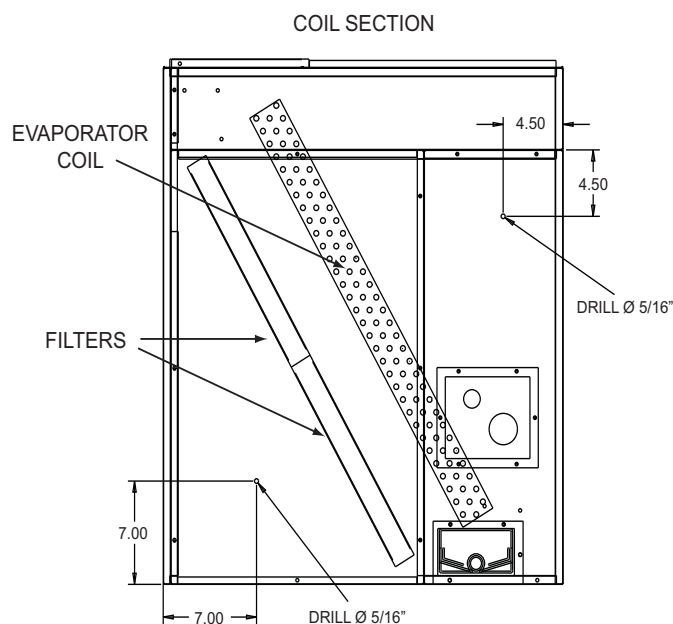

Figure 21: Hole Location For Pressure Drop Reading

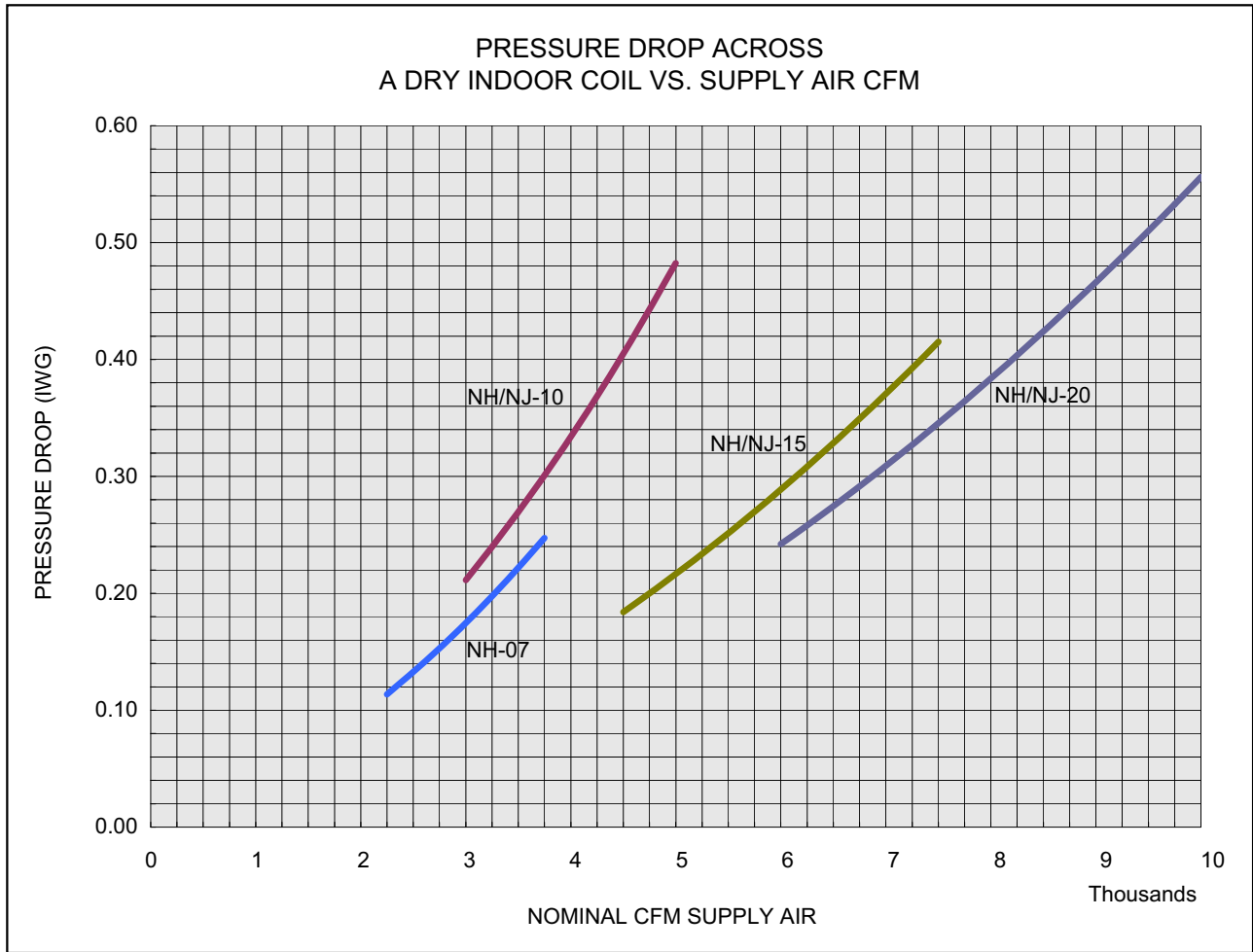

Figure 22: Pressure Drop Across A Dry Indoor Coil vs. Supply Air CFM

Belt Tension

The tension on the belt should be adjusted as shown in Figure 23.

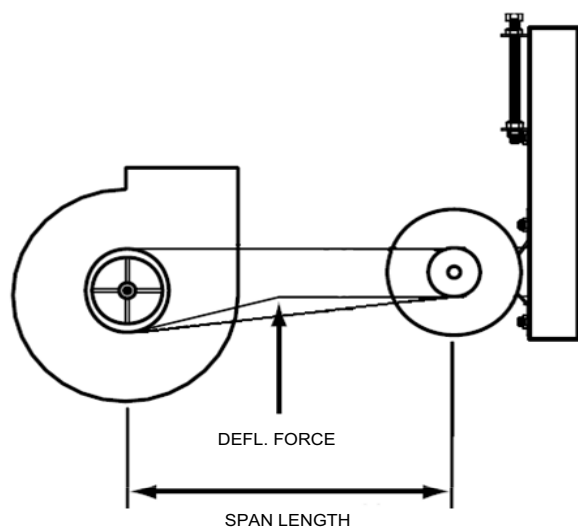
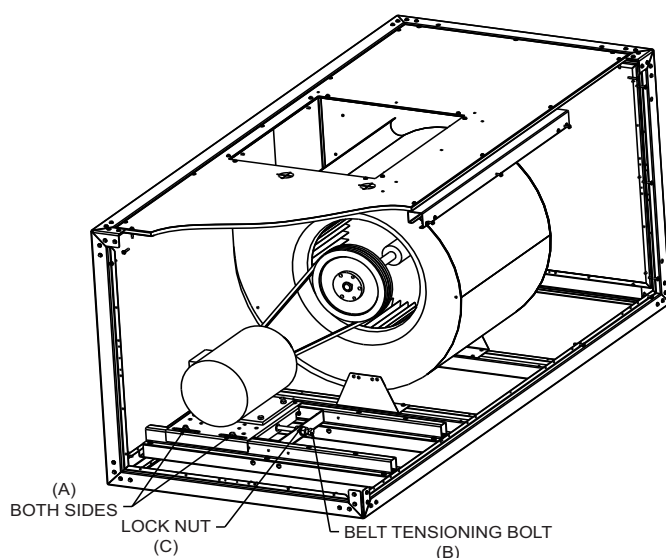

Figure 23: Belt Adjustment

CAUTION

Procedure for adjusting belt tension:

1. Loosen four nuts (top and bottom) of the Belt Adjust/ Motor Mounting Bracket (A).
2. Loosen Lock Nut (C).
3. Adjust by turn Belt Tensioning Bolt (B).
4. Use belt tension checker to apply a perpendicular force to one belt at the midpoint of the span as shown. Deflection distance of 4mm (5/32") is obtained.

To determine the deflection distance from normal position, use a straight edge from sheave to sheave as reference line. The recommended deflection force is as follows:

Tension new belts at the max. deflection force recommended for the belt section. Check the belt tension at least two times during the first 24 hours of operation. Any retensioning should fall between the min. and max. deflection force values.

5. After adjusting re-tighten nuts (A) and Lock Nut (C).

Twin Belt Drive Adjustment

Check to see if both belts drive at the same speed. Do this by making a mark across both belts. Turn the drive several revolutions by hand. If the mark has not separated, the belts are traveling at the same speed.

Twin groove blower motor pulleys should be installed with the shaft set screw (A) towards the motor (see Figure 24).

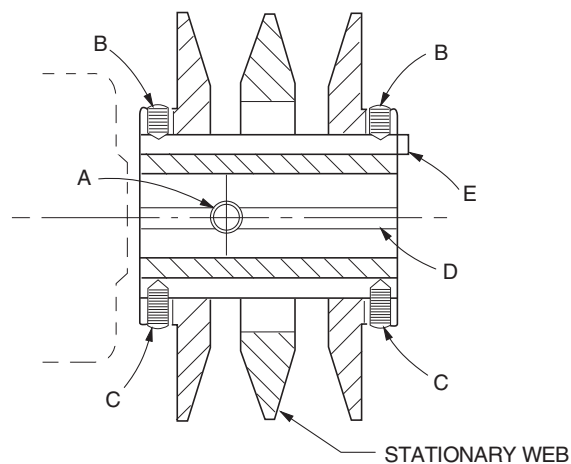

Figure 24: Double Groove Pulley

If necessary to align pulleys, the housing of the twin groove motor pulley may extend 25% of its length beyond end of motor shaft.

Always align twin groove pulleys using the stationary web.

The blower motor pulleys are adjustable by half turns. Select required RPM from Airflow Performance tables and adjust pulley.

Sequence of Operation

Blower Sequence of Operation

Continuous Blower

Set the room thermostat fan switch to "ON". The 24V signal provided to the "G1" terminal directly from the thermostat or from the condenser / heat pump closes the coil of the fan motor relay (BR1).

- Relay BR1 controls the coil for contactor M1.
- Contactor M1 controls the indoor fan motor FM1.

Intermittent Blower

Set the room thermostat fan switch to "AUTO" and set the system switch to "AUTO" or "HEAT". During a call for cooling or heating, the 24V signal provided to the "G1" terminal directly from the thermostat or from the condenser / heat pump closes the coil of the fan motor relay (BR1).

- Relay BR1 controls the coil for contactor M1.
- Contactor M1 controls the indoor fan motor FM1.

Cooling Sequence of Operation

Single Stage Evaporator Unit (NH-07)

No additional input signal is required to operate the evaporator unit during cooling (See Figures 8 and 12). The evaporator coil operates with only one system of cooling.

Dual Stage, 2-Pipe Evaporator Unit (NH-10 thru -20)

When the thermostat calls for the first stage of cooling (Y1), a 24V signal is provided to the "S1" terminal directly from the condenser / heat pump (See Figures 9 and 13). This signal closes the coil of the solenoid control relay (RY1). The evaporator coil operates the lower refrigeration system only.

When the thermostat calls for the second stage of cooling (Y2), a 24V signal is provided to the "S2" terminal directly from the condenser / heat pump. This signal closes the coil of the solenoid control relay (RY2). The relays RY1 and RY2 operating in series then energize the solenoid valve (1LLS) allowing refrigerant to flow through the upper refrigeration system.

NOTE: The unit controls are designed to allow lead-lag compressor operation. When both compressors are operating, the solenoid valve opens. If either compressor stops, its matching solenoid control relay closes thus closing shutting down the upper refrigeration system.

Dual Stage, 4-Pipe Evaporator Unit (NJ-10 thru -20)

No additional input signal is required to operate the evaporator unit during cooling (See Figures 11 and 15). The evaporator coil operates with two independent, fully intertwined systems of cooling.

Twin Single Stage Evaporator Unit (NH-07)

A dual-stage, four-pipe condenser / heat pump is required to operate this twin, single stage evaporator unit combination. Independent "G" calls are required to operate the blowers. No other input signals are required to operate the evaporator units during cooling (See Figure 19).

Twin Dual Stage, 2-Pipe Evaporator Units (NH-10 thru -20)

A dual-stage, four-pipe condenser / heat pump is required to operate this twin, dual-stage evaporator unit combination. Corresponding calls for cooling and blower operation connect to the "S1" and "G1" terminals, respectively, of each evaporator unit's control box terminal block (TB2) (See Figure 16). No other input signals are required for cooling operation. Each evaporator coil operates both fully intertwined systems of cooling.

NOTE: Relay RY2 must be removed from each evaporator unit's control circuit. Solenoid valve 1LLS must be wired directly to relay RY1. When the matching system compressor is operating, the solenoid valve opens.

Twin Condensers, Single 4-Pipe Evaporator Unit (NJ-10 thru -20)

Twin two-pipe condensers / heat pumps are required to operate this single, 4-pipe evaporator unit combination. A "G" call from either condenser / heat pump operates the blower (See Figure 17). No other input signal is required for cooling operation. The evaporator coil operates with two independent, fully intertwined systems of cooling.

Maintenance

Filters must be cleaned or replaced as often as necessary to assure good airflow and filtering action.

To remove filters through the side of the unit, remove the solid side panel from either end of the unit.

To remove the filters from the front of the unit, open access panel. The filters can be lifted out through the access panel.

The drain pan should be inspected regularly to assure proper drainage.

Blower bearings and motor bearings are permanently lubricated.

Top View

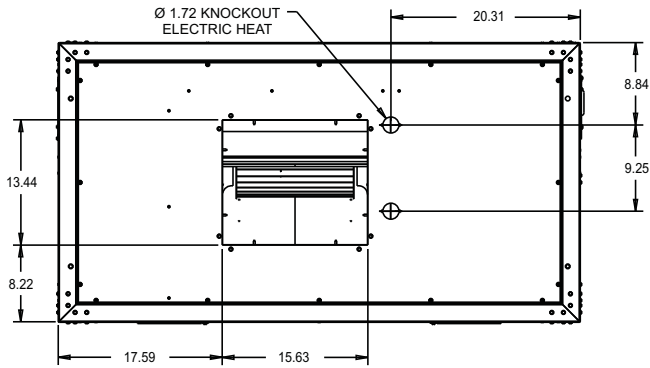

TOP VIEW - BLOWER OUTLET
NH-07 INDOOR

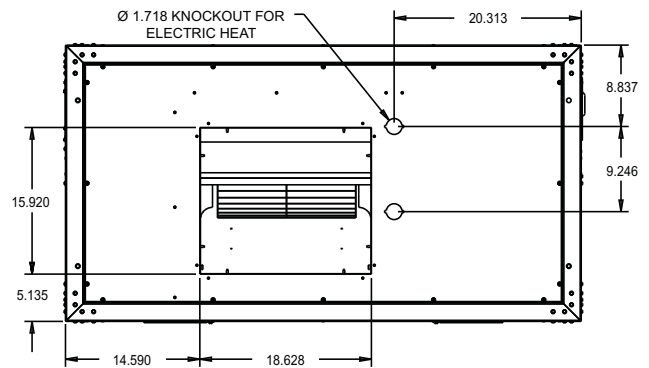

TOP VIEW - BLOWER OUTLET
NH/NJ-10 INDOOR

Front and Side View

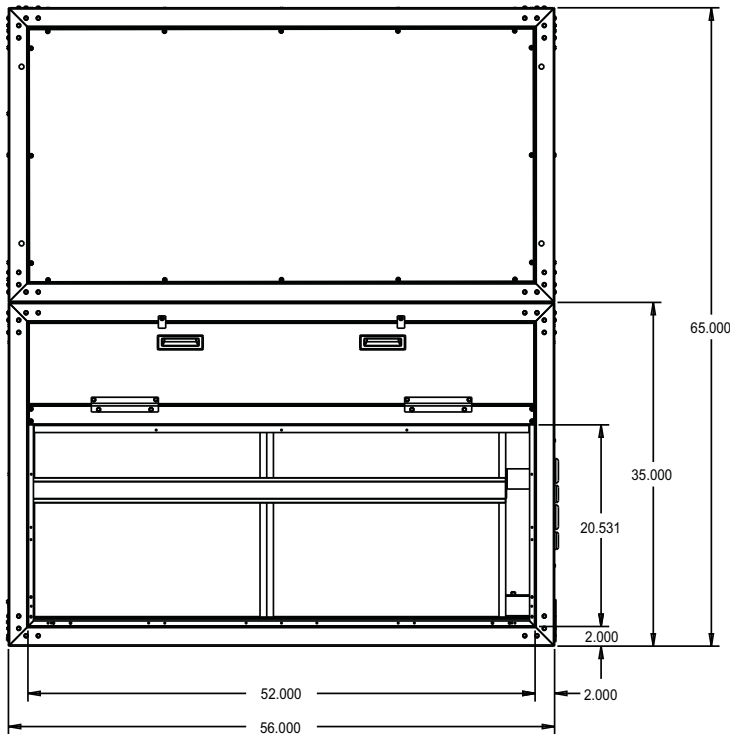

FRONT VIEW - RETURN AIR
NH-07/-10 & NJ-10 INDOOR

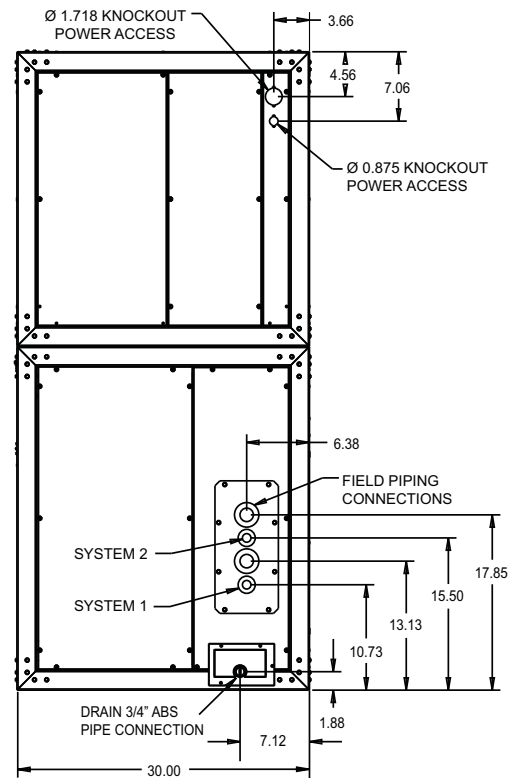

RIGHT SIDE VIEW - DRAIN PIPING/CONTROLS

Figure 25: Unit Dimensions NH-07/-10 & NJ-10

NOTE: Use System 1 piping dimensions when applying a NH-07/-10 model system.

Bottom View

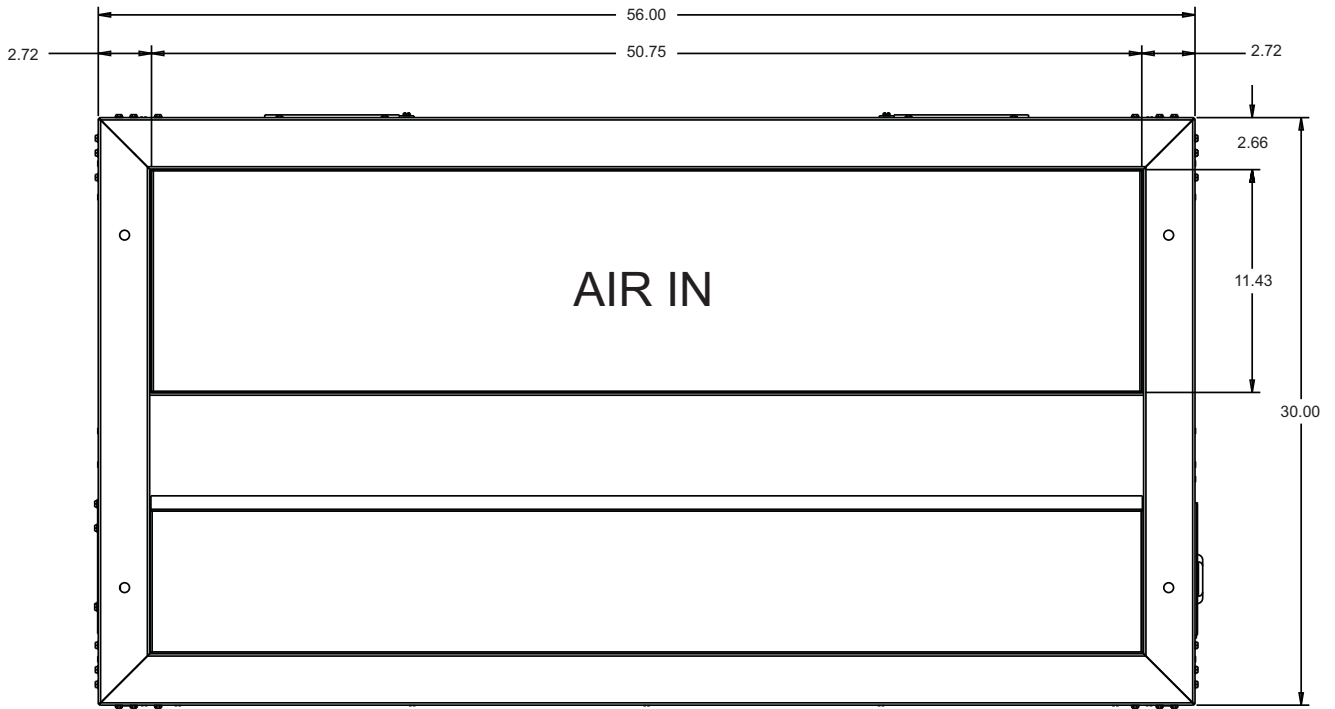

Horizontal Configuration

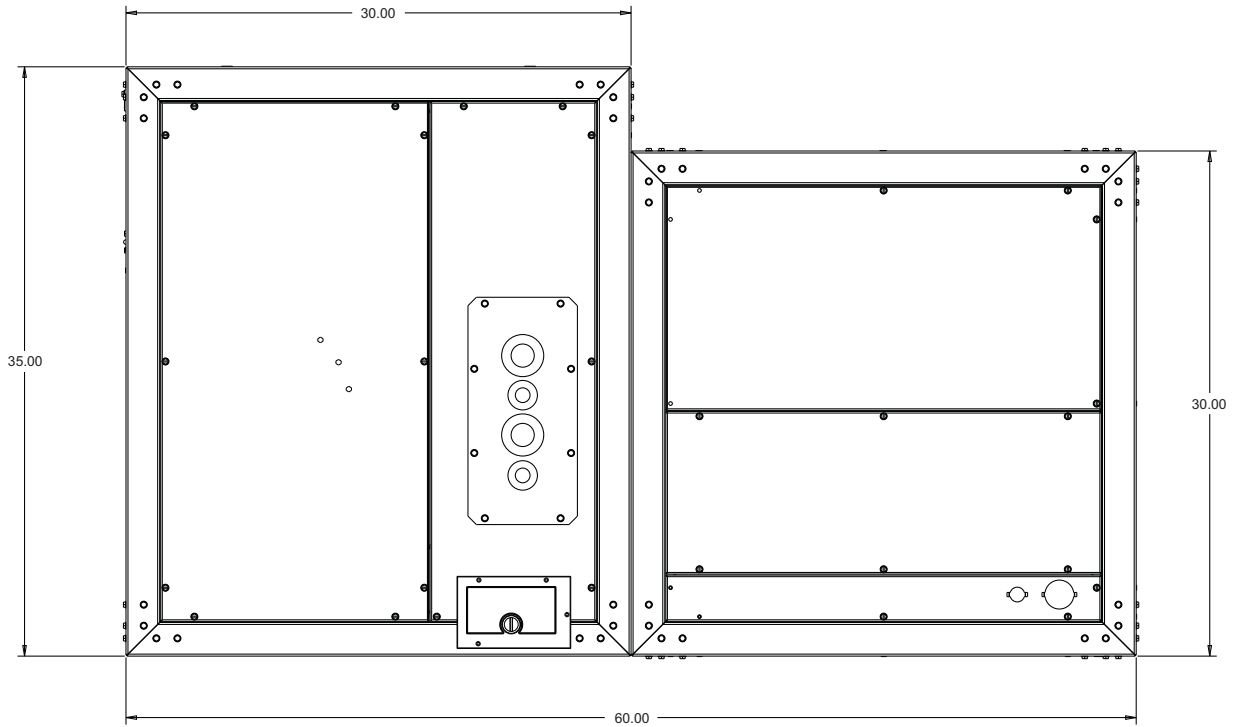

Figure 24: Unit Dimensions NH-07/-10 & NJ-10 (Continued)

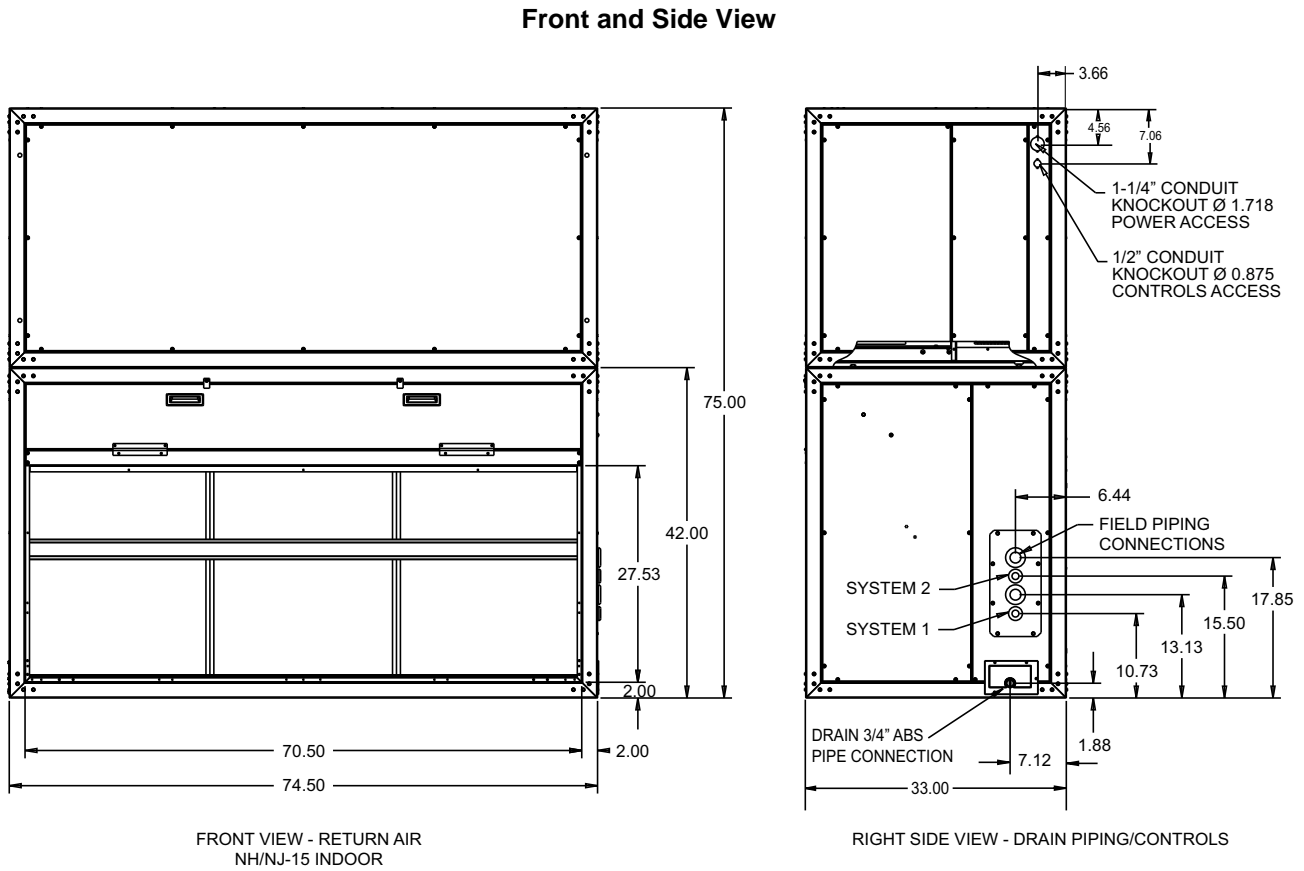
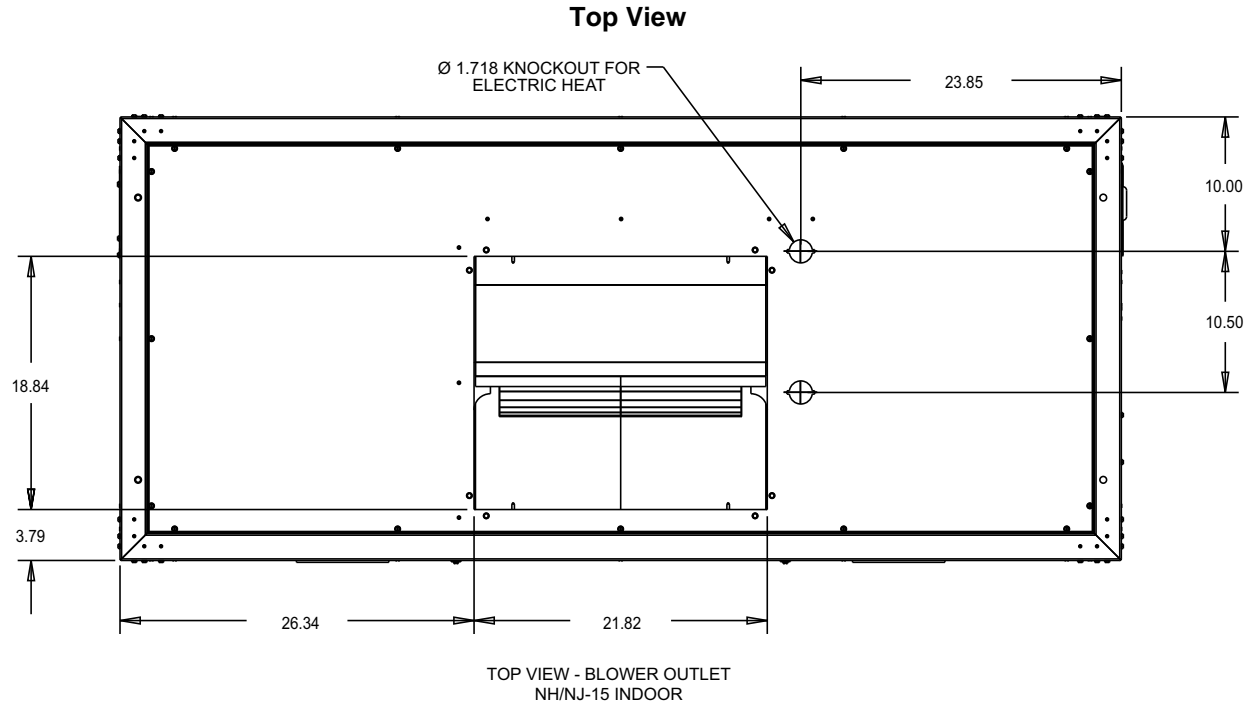
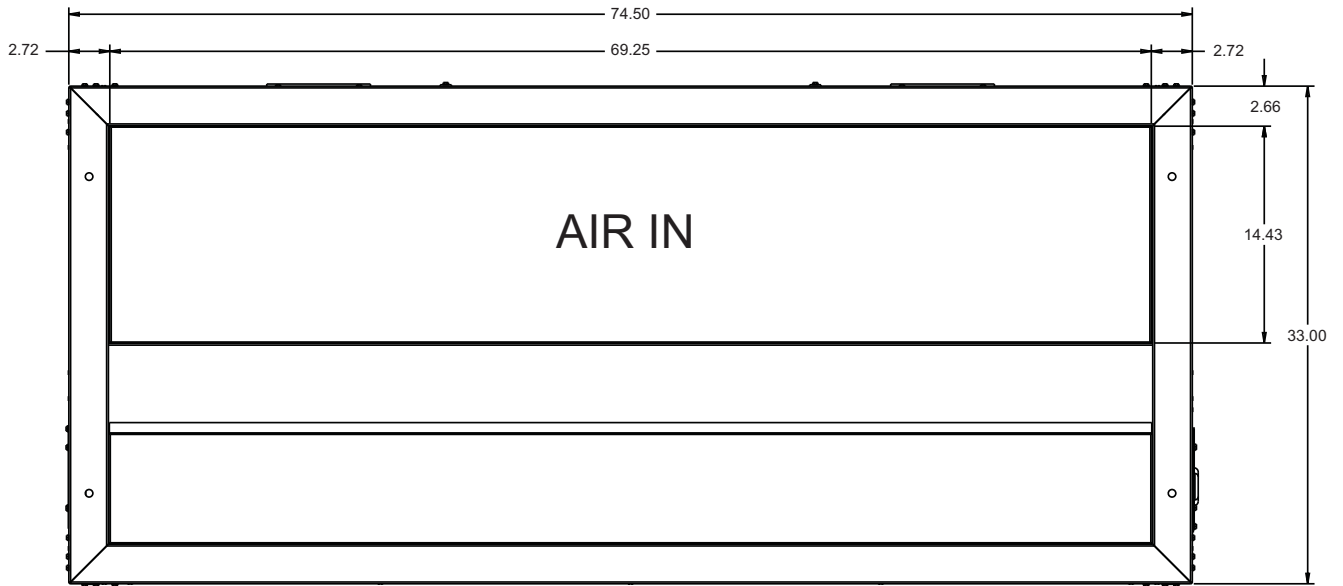

Figure 26: Unit Dimensions NH/NJ-15

NOTE: Use System 1 piping dimensions when applying a NH-15 model system.

Bottom View



Horizontal Configuration

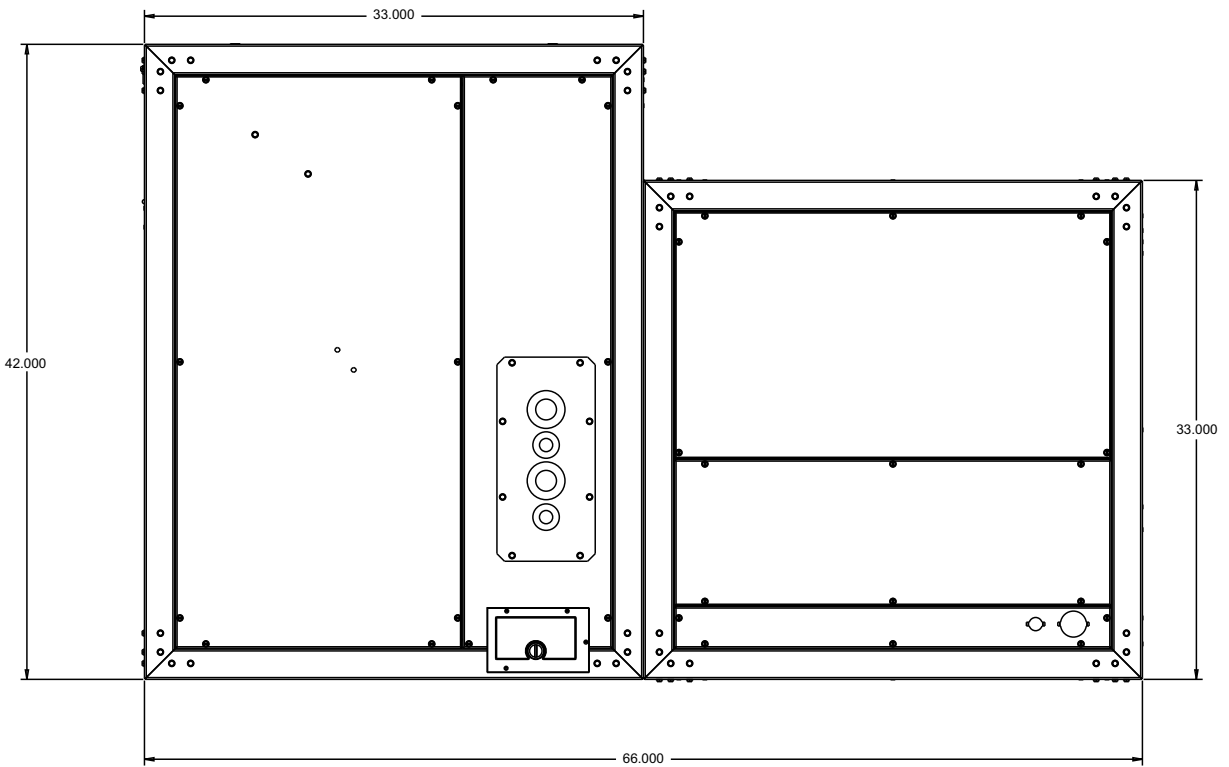
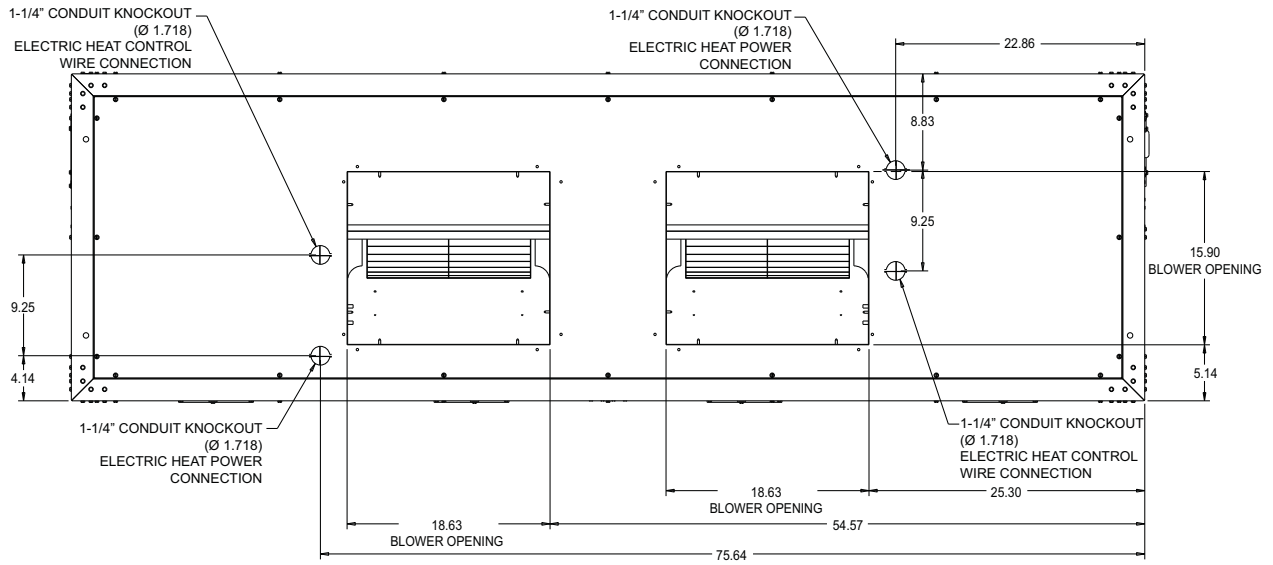

Figure 25: Unit Dimensions NH/NJ-15 (Continued)

Top View



TOP VIEW BLOWER OUTLET
NH/NJ-20 INDOOR

Front and Side View

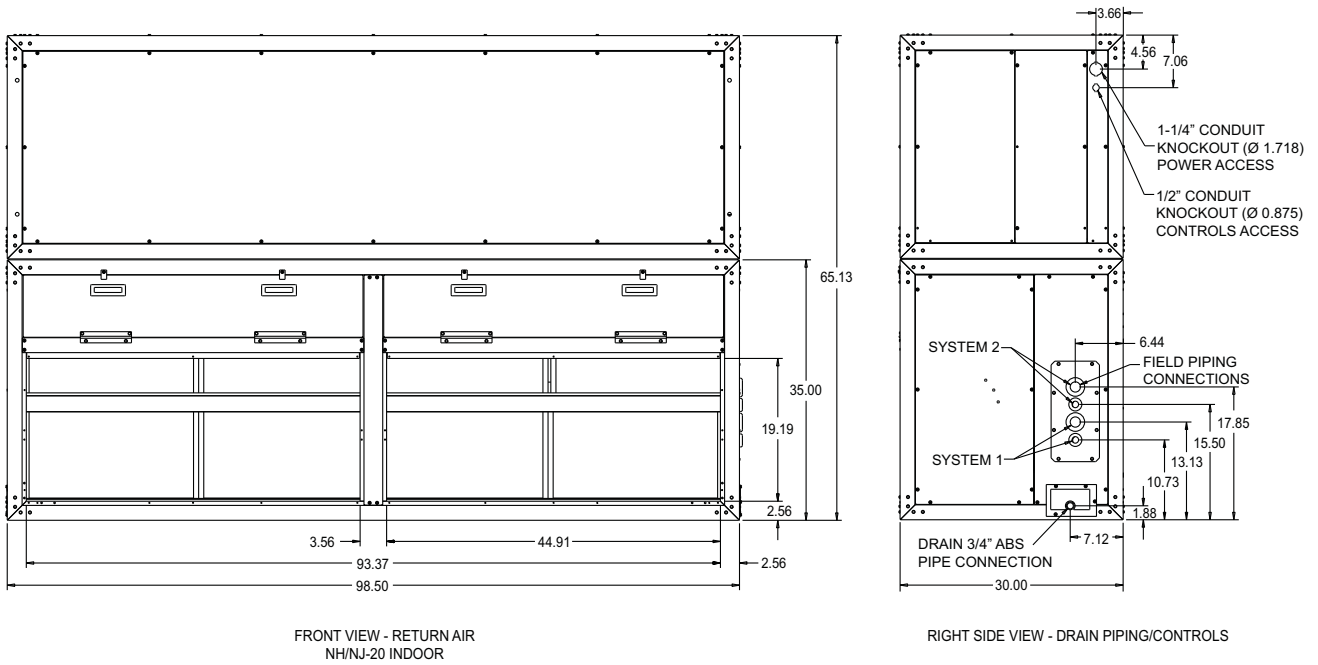
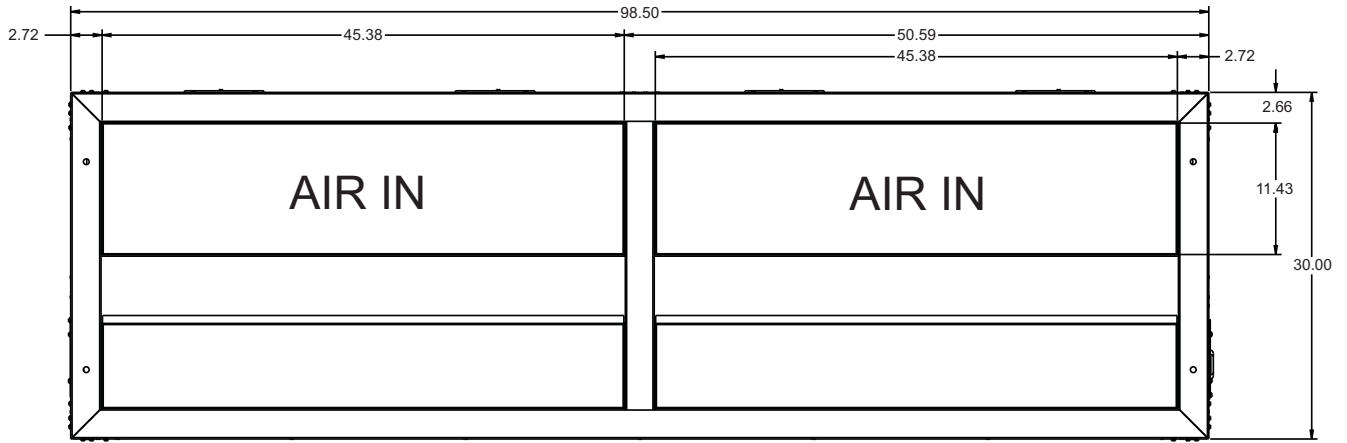

Figure 27: Unit Dimensions NH/NJ-20

NOTE: Use System 1 piping dimensions when applying a NH-20 model system.

BOTTOM VIEW



Horizontal Configuration

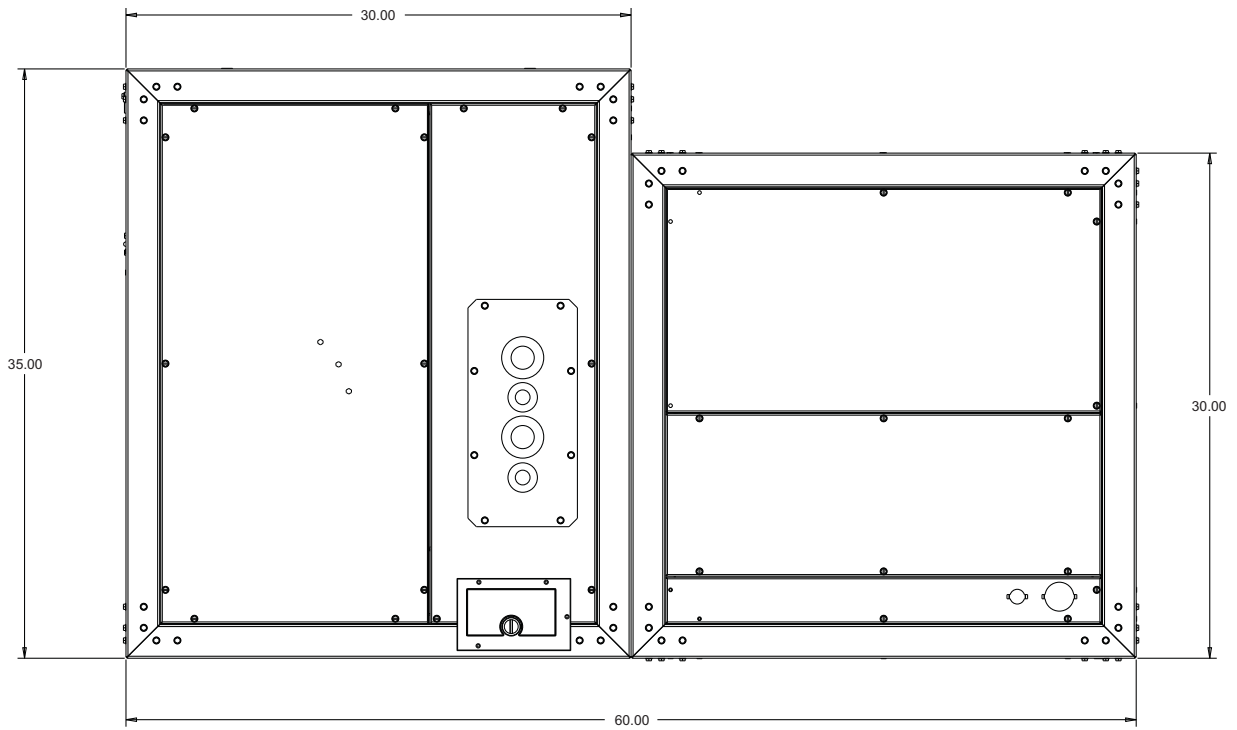

Figure 26: Unit Dimensions NH/NJ-20 (Continued)

Table 18: Piping, Electrical and Duct Opening Connection Sizes

MODEL	NH-07	NH-10	NJ-10	NH-15	NJ-15	NH-20	NJ-20
SYSTEM DATA							
No. Refrigeration Circuits	1	1	2	1	2	1	2
Suction Line OD (in.)	1 1/8	1 3/8	1 1/8	1 5/8	1 3/8	1 5/8	1 3/8
Liquid Line OD (in.)	5/8	7/8	5/8	7/8	5/8	7/8	7/8
Power Wiring Knockout	1 3/4	1 3/4	1 3/4	1 3/4	1 3/4	1 3/4	1 3/4
Control Wiring Knockout	7/8	7/8	7/8	7/8	7/8	7/8	7/8
Electric Heat Wiring Knockout	1 3/4	1 3/4	1 3/4	1 3/4	1 3/4	1 3/4	1 3/4
Drain Line Fitting PVC Stub	3/4	3/4	3/4	3/4	3/4	3/4	3/4
BLOWER OUTLET							
Number	1	1	1	1	1	2	2
Width	13.4	15.9	15.9	18.9	18.9	15.9	15.9
Length	15.6	18.6	18.6	21.6	21.6	18.6	18.6
RETURN AIR INLET							
Width	20.5	20.5	20.5	27.3	27.3	19.2	19.2
Length	52.0	52.0	52.0	71.9	71.9	93.4	93.4

Typical Wiring Diagrams

Air Handling Units

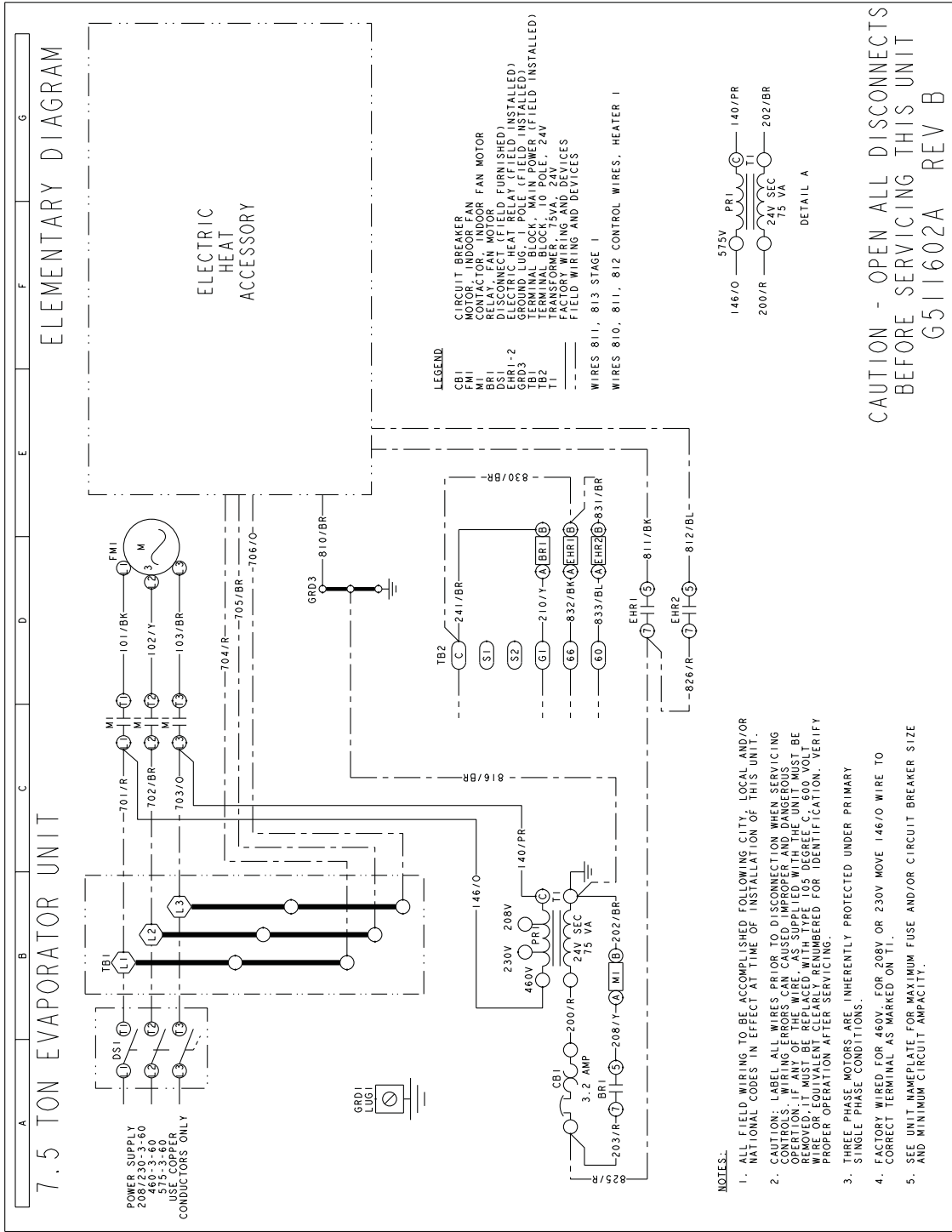

Figure 28: Typical NH-07 Wiring Diagram

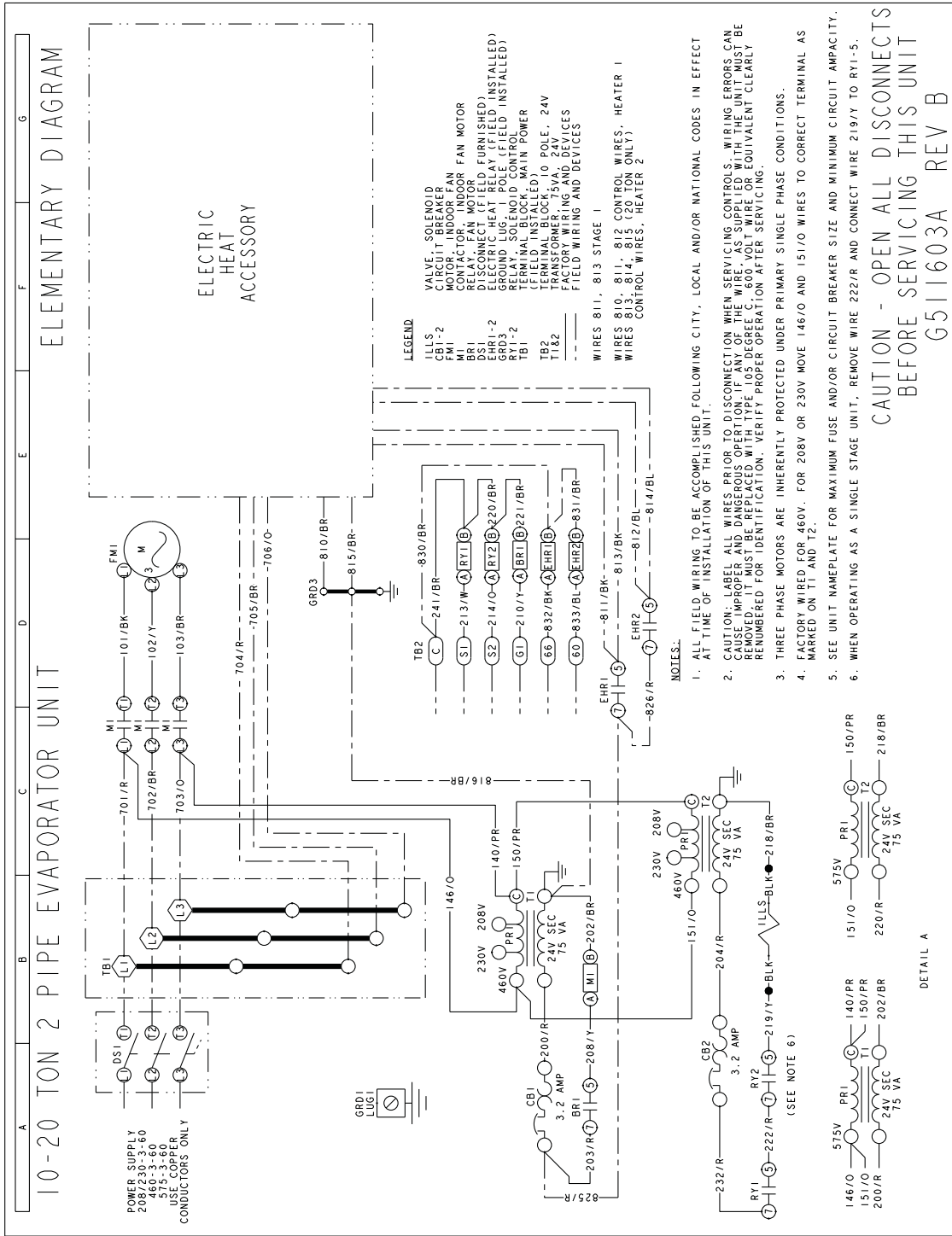

Figure 29: Typical NH-10 thru -20, 1.5 Thru 5 HP Blower Motor Only Wiring Diagram

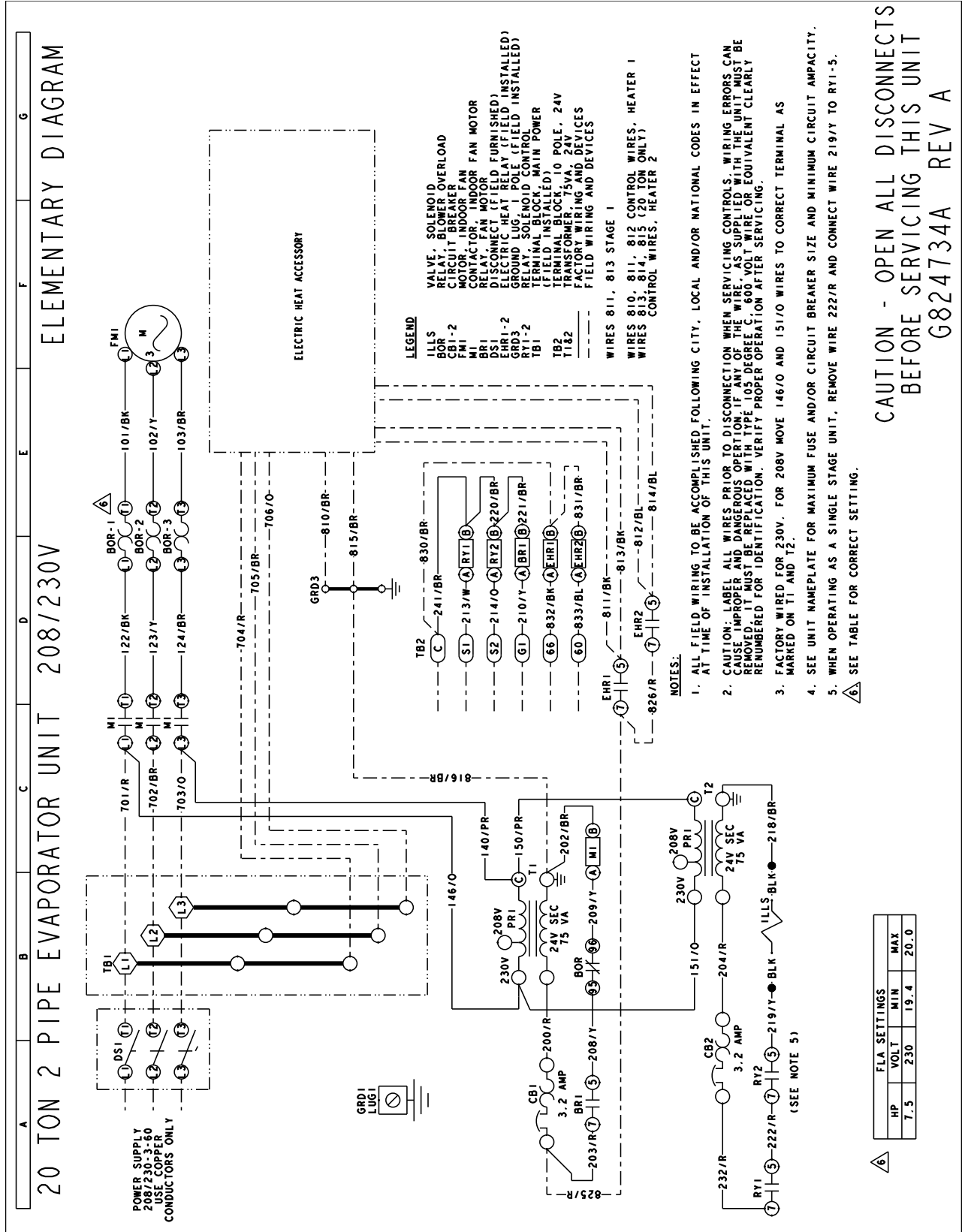

Figure 30: Typical NH-20, 7.5 HP Blower Motor 208/230 V Only Wiring Diagram

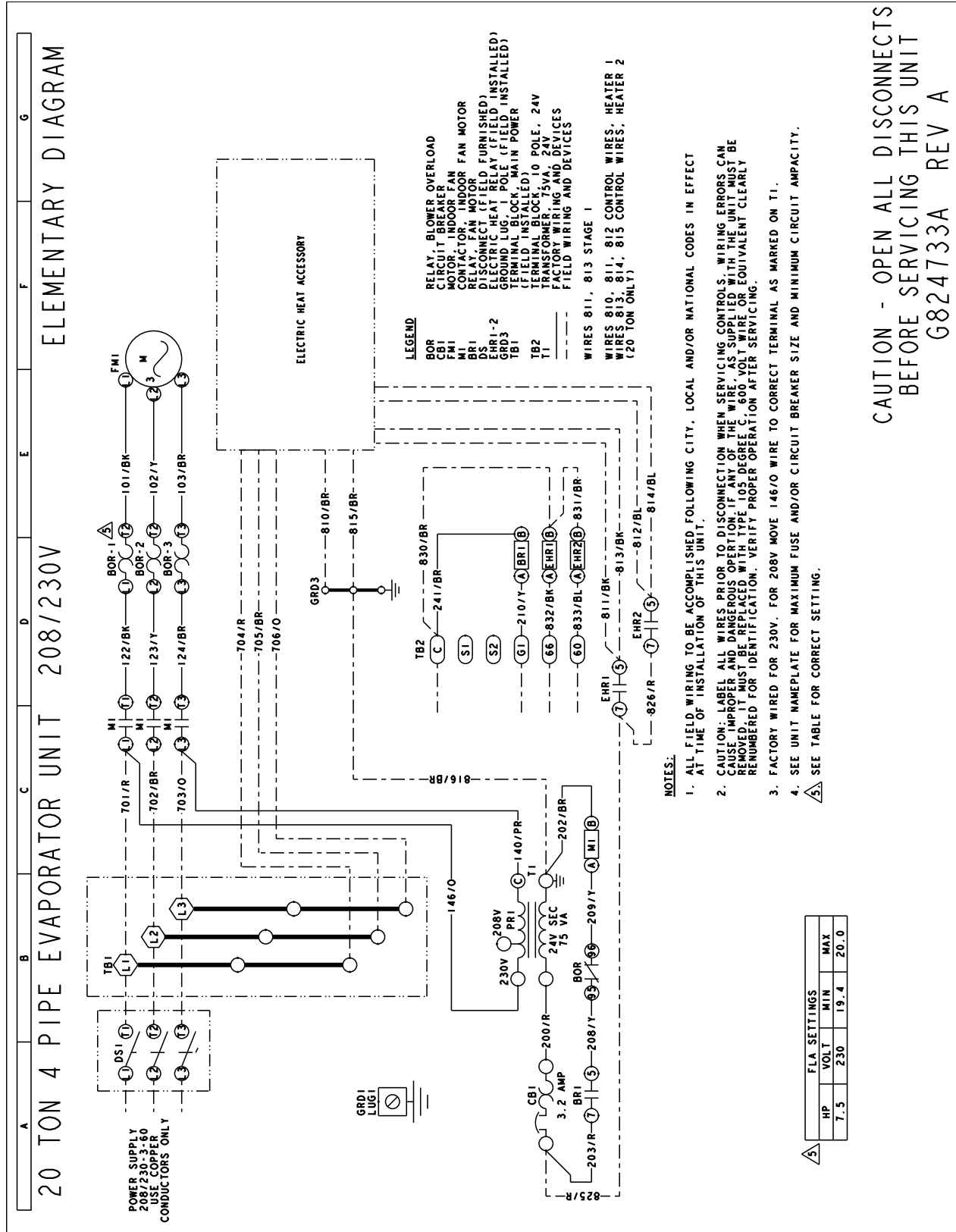
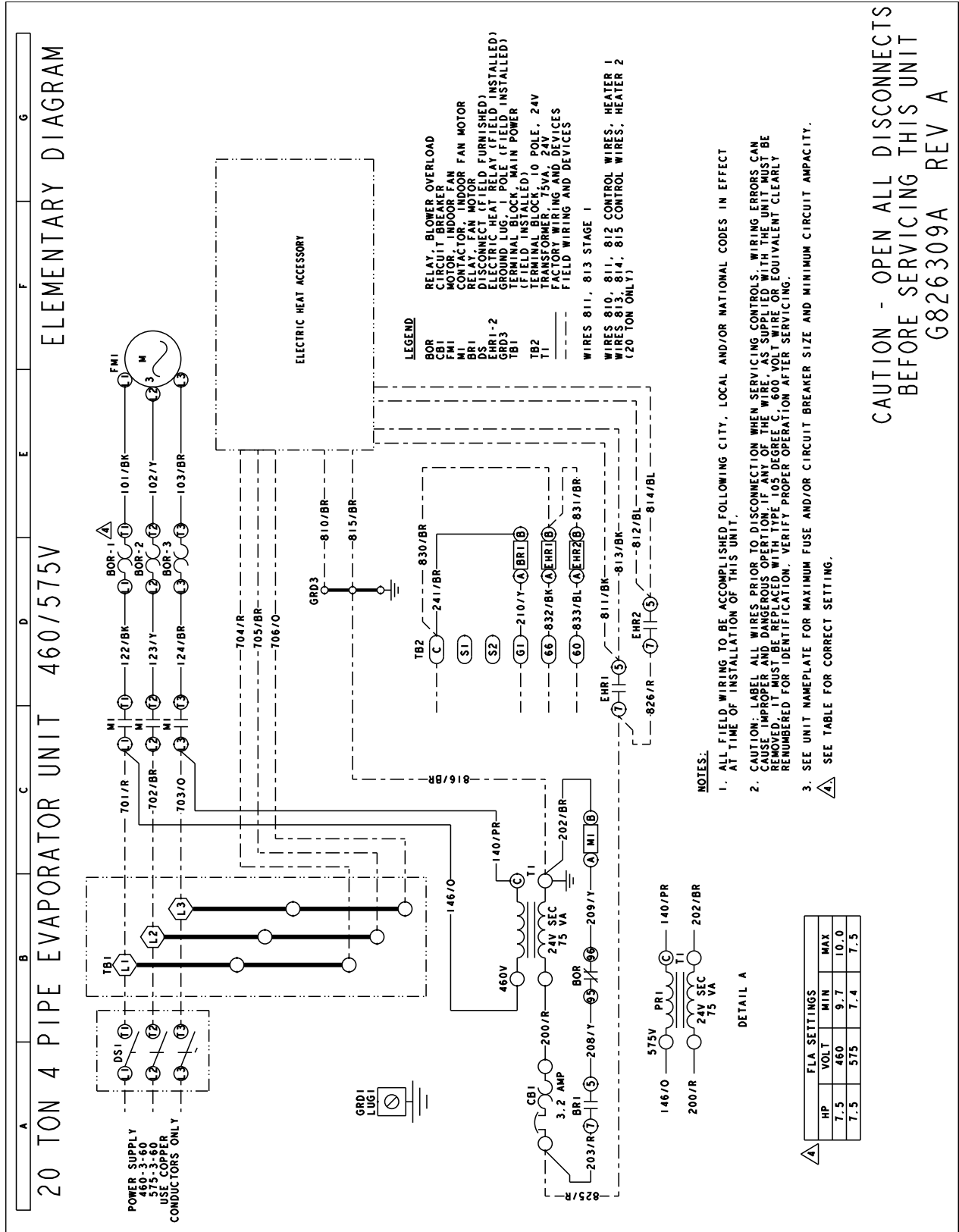

Figure 33: Typical NJ-20, 7.5 HP Blower Motor 208/230 V Only Wiring Diagram



**CAUTION - OPEN ALL DISCONNECTS
BEFORE SERVICING THIS UNIT**
G826309A REV A

Start-Up Sheet

START-UP & SERVICE DATA INSTRUCTION

COMMERCIAL SPLIT SYSTEMS

7.5 To 50.0 TON

START-UP CHECKLIST

Date: _____

Job Name: _____

Customer Name: _____

Address: _____

City: _____ State: _____ Zip: _____

Evaporator Model Number: _____ Serial Number: _____

Condenser Model Number: _____ Serial Number: _____

Qualified Start-up Technician: _____ Signature: _____

HVAC Contractor: _____ Phone: _____

Address: _____

Contractor's E-mail Address: _____

Electrical Contractor: _____ Phone: _____

Distributor Name: _____ Phone: _____

WARRANTY STATEMENT

Johnson Controls/UPG is confident that this equipment will operate to the owner's satisfaction if the proper procedures are followed and checks are made at initial start-up. This confidence is supported by the 30 day dealer protection coverage portion of our standard warranty policy which states that Johnson Controls/UPG will cover parts and labor on new equipment start-up failures that are caused by a defect in factory workmanship or material, for a period of 30 days from installation. Refer to current standard warranty policy and warranty manual found on UPGnet for details.

In the event that communication with Johnson Controls/UPG is required regarding technical and/or warranty concerns, all parties to the discussion should have a copy of the equipment start-up sheet for reference. A copy of the original start-up sheet should be filed with the Technical Services Department.

The packaged unit is available in constant or variable air volume versions with a large variety of custom options and accessories available. Therefore, some variation in the startup procedure will exist depending upon the products capacity, control system, options and accessories installed.

This start-up sheet covers all startup check points common to all package equipment. In addition it covers essential startup check points for a number of common installation options. Depending upon the particular unit being started not all sections of this startup sheet will apply. Complete those sections applicable and use the notes section to record any additional information pertinent to your particular installation.

Warranty claims are to be made through the distributor from whom the equipment was purchased.

EQUIPMENT STARTUP

Use the local LCD or Mobile Access Portal (MAP) Gateway to complete the start-up.

A copy of the completed start-up sheet should be kept on file by the distributor providing the equipment and a copy sent to:

Johnson Controls/UPG
Technical Services Department
5005 York Drive
Norman, OK 73069

SAFETY WARNINGS

The inspections and recording of data outlined in this procedure are required for start-up of Johnson Controls/UPG's packaged products. Industry recognized safety standards and practices must be observed at all times. General industry knowledge and experience are required to assure technician safety. It is the responsibility of the technician to assess all potential dangers and take all steps warranted to perform the work in a safe manner. By addressing those potential dangers, prior to beginning any work, the technician can perform the work in a safe manner with minimal risk of injury.

 WARNING
Lethal voltages are present during some start-up checks. Extreme caution must be used at all times.

 WARNING
Moving parts may be exposed during some startup checks. Extreme caution must be used at all times.

NOTE: Read and review this entire document before beginning any of the startup procedures.

DESIGN APPLICATION INFORMATION

This information will be available from the specifying engineer who selected the equipment. If the system is a VAV system the CFM will be the airflow when the remote VAV boxes are in the

full open position and the frequency drive is operating at 60 HZ. **Do not proceed with the equipment start-up without the design CFM information.**

Design Supply Air CFM: _____ Design Return Air CFM: _____

Design Outdoor Air CFM At Minimum Position: _____

Total External Static Pressure: _____

Supply Static Pressure: _____

Return Static Pressure: _____

Design Building Static Pressure: _____

ADDITIONAL APPLICATION NOTES FROM SPECIFYING ENGINEER:

1034350-UCL-B-1114

REFERENCE

General Inspection	Completed	See Notes
Unit inspected for shipping, storage, or rigging damage	<input type="checkbox"/>	<input type="checkbox"/>
Unit installed with proper clearances	<input type="checkbox"/>	<input type="checkbox"/>
Unit installed within slope limitations	<input type="checkbox"/>	<input type="checkbox"/>
Refrigeration system checked for gross leaks (presence of oil)	<input type="checkbox"/>	<input type="checkbox"/>
Terminal screws and wiring connections checked for tightness	<input type="checkbox"/>	<input type="checkbox"/>
Filters installed correctly and clean	<input type="checkbox"/>	<input type="checkbox"/>
Condensate drain trapped properly, refer to Installation Manual	<input type="checkbox"/>	<input type="checkbox"/>
All field wiring (power and control) complete	<input type="checkbox"/>	<input type="checkbox"/>

Refrigerant Line Inspection	System 1		System 2	
Is Condenser below Evaporator?	Yes <input type="checkbox"/>	No <input type="checkbox"/>	Yes <input type="checkbox"/>	No <input type="checkbox"/>
Total Line Length end to end.	_____ Ft.		_____ Ft.	
Vertical Lift in Ft.	_____ Ft.		_____ Ft.	
Vertical Fall in Ft.	_____ Ft.		_____ Ft.	
Number of Elbows?	_____ Ea.		_____ Ea.	
Liquid Line Size	_____ Ea.		_____ Ea.	
Suction Line Size	_____ Ea.		_____ Ea.	
Solenoid Valve?	Yes <input type="checkbox"/>	No <input type="checkbox"/>	Yes <input type="checkbox"/>	No <input type="checkbox"/>
Check Valves?	Yes <input type="checkbox"/>	No <input type="checkbox"/>	Yes <input type="checkbox"/>	No <input type="checkbox"/>
Check Valves / Solenoid arrangements installed as per UPG Piping Guide	Yes <input type="checkbox"/>	No <input type="checkbox"/>	Yes <input type="checkbox"/>	No <input type="checkbox"/>
Oil Separator ?	Yes <input type="checkbox"/>	No <input type="checkbox"/>	Yes <input type="checkbox"/>	No <input type="checkbox"/>
Accumulator ?	Yes <input type="checkbox"/>	No <input type="checkbox"/>	Yes <input type="checkbox"/>	No <input type="checkbox"/>
TXV - Hard shutoff	Yes <input type="checkbox"/>	No <input type="checkbox"/>	Yes <input type="checkbox"/>	No <input type="checkbox"/>
Heatpump	Yes <input type="checkbox"/>	No <input type="checkbox"/>	Yes <input type="checkbox"/>	No <input type="checkbox"/>

Air Moving Inspection	Completed	See Notes
Alignment of drive components	<input type="checkbox"/>	<input type="checkbox"/>
Belt tension adjusted properly	<input type="checkbox"/>	<input type="checkbox"/>
Blower pulleys tight on shaft, bearing set screws tight, wheel tight to shaft	<input type="checkbox"/>	<input type="checkbox"/>
Pressure switch or transducer tubing installed properly	<input type="checkbox"/>	<input type="checkbox"/>

Operating Measurements - Air Flow

Fan operates with proper rotation	ID Fans <input type="checkbox"/>	Exh. Fans <input type="checkbox"/>	Cond. Fans <input type="checkbox"/>
Pressure drop across dry evaporator coil (At maximum design CFM) ¹			IWC
External Static Pressure			IWC
Return Static Pressure			IWC
Supply Static Pressure			IWC
Supply Air CFM Using Dry Coil Chart			CFM
Final Adjusted Supply Air CFM ²			CFM

1. Consult the proper airflow to pressure drop table to obtain the actual airflow at the measured pressure differential.
2. Was a motor pulley adjustment or change required to obtain the correct airflow?
 Was it necessary to increase of decrease the airflow to meet the design conditions?
 If the motor pulley size was changed, measure the outside diameters of the motor and blower pulleys and record those diameters here;

Blower Motor HP _____ FLA _____ RPM _____

Pulley Pitch Diameter _____ Turns Out _____ Final Turns Out _____

Blower Pulley Pitch Diameter _____ Fixed Sheave _____

ELECTRICAL DATA

T1 - T2 _____ Volts T2 - T3 _____ Volts
 Control Voltage _____ Volts T1 - T3 _____ Volts

Device	Nameplate	Measured List All Three Amperages
Supply Fan Motor ^{1,2}	AMPS	AMPS
Condenser Fan #1	AMPS	AMPS
Condenser Fan #2 (if equipped)	AMPS	AMPS
Condenser Fan #3 (if equipped)	AMPS	AMPS
Condenser Fan #4 (if equipped)	AMPS	AMPS
Compressor #1	AMPS	AMPS
Compressor #2 (if equipped)	AMPS	AMPS
Compressor #3 (if equipped)	AMPS	AMPS
Compressor #4 (if equipped)	AMPS	AMPS

1. VAV units with heat section - simulate heat call to drive VAV boxes and VFD/IGV to maximum design airflow position.
 2. VAV units without heat section - VAV boxes must be set to maximum design airflow position.
- Notes above apply for 3rd party application only.

1034350-UCL-B-1114

OPERATING MEASUREMENTS - COOLING

Stage	Discharge Pressure	Discharge Temp.	Liquid Line Pressure At Service Valve	Liquid Line Temp. ¹	Subcooling ²	Suction Pressure	Suction Temp.	Superheat
First ³	#	°	#	°	°	#	°	°
Second (if equipped)	#	°	#	°	°	#	°	°
Third (if equipped)	#	°	#	°	°	#	°	°
Fourth (if equipped)	#	°	#	°	°	#	°	°
Heat Pump 1st Stage	#	°	#	°	°	#	°	°

- 1. Liquid line temperature should be taken before filter/drier.
- 2. Subtract 10 psi from discharge pressure for estimated liquid line pressure
- 3. If Rawal valve installed, contact Technical Service.

Outside air temperature _____ db °F _____ wb °F _____ RH%

Return Air Temperature _____ db °F _____ wb °F _____ RH%

Mixed Air Temperature _____ db °F _____ wb °F _____ RH%

Supply Air Temperature _____ db °F _____ wb °F _____ RH%

REFRIGERANT SAFETIES

Action	Completed	See Notes
Prove Compressor Rotation (3 phase only) by guage pressure	<input type="checkbox"/>	<input type="checkbox"/>
Prove High Pressure Safety, All Systems	<input type="checkbox"/>	<input type="checkbox"/>
Prove Low Pressure Safety, All Systems	<input type="checkbox"/>	<input type="checkbox"/>

OPERATING MEASUREMENTS ELECTRIC HEATING

Heater kW _____ kW Heater Voltage, Nameplate _____ Volts

Heater Model Number: _____

Serial Number: _____

Heater	Nameplate	Measured List All Three Amperages		
Stage 1	_____ AMPS	_____ AMPS	_____ AMPS	_____ AMPS
Stage 2	_____ AMPS	_____ AMPS	_____ AMPS	_____ AMPS
Stage 3	_____ AMPS	_____ AMPS	_____ AMPS	_____ AMPS
Stage 4	_____ AMPS	_____ AMPS	_____ AMPS	_____ AMPS
Checked Heater Limit		Yes <input type="checkbox"/>	No <input type="checkbox"/>	
Air Moving Switch Installed?		Yes <input type="checkbox"/>	No <input type="checkbox"/>	

