

697.4

BULLETIN "C"

McALEAR

Vacuum Air Line Heating
System

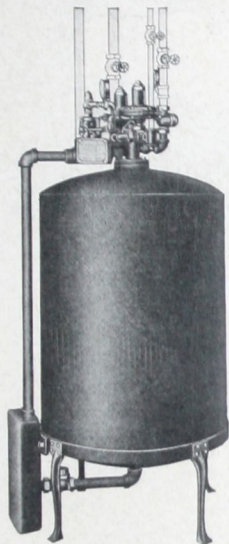

Descriptive of the McAlear Vacuum
Air Line System of Heating

THE McALEAR MFG. CO.

1901-7 SO. WESTERN AVENUE
CHICAGO, ILL.

McAlear
Automatic
Vacuum
Pump

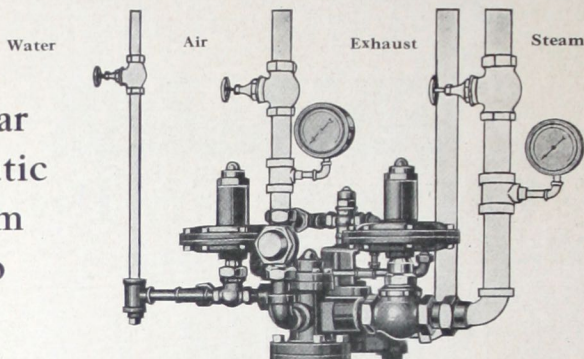

(Patented and Patents Pending)

For detail description and operation,
see pages 3 to 5 inclusive.
For capacities and prices,
see page 6.

Operation of McAlear Automatic Vacuum Pump and Its Advantages

So that you will understand how simple and easy is the operation of The McAlear Automatic Vacuum Pump and why it cannot fail to live up to the claims we make for it, here is a brief outline of the facts.

The Pump consists of a large cylinder which stands vertically on a substantial base. On top of the cylinder is mounted the Automatic Valve mechanism to which all air, steam and water connections are made.

The air connections consist of the vacuum air lines, which connect with all of the air valves on the radiators throughout the building or plant, as outlined and described in the specifications, which will be sent to any one, on demand.

The steam for operating the pump is taken from low-pressure heating main or from boiler direct (if operated low-pressure), and connected to the steam valve, which is made a part of the Automatic Valve mechanism referred to above.

The water for condensing purposes is taken from the city water pressure and connected to the Water Valve, which is also made a part of the Automatic Valve mechanism. One of the McAlear advantages lies in the fact that all of these connections are controlled and operated by means of the Automatic Valve mechanism and Thermostatic motor, mounted on top of cylinder, as outlined above.

The Operation. When the Pump is in operation, steam enters the cylinder through steam valve and forces the air contained therein out through the discharge pipe at the bottom into the water seal trap. After the air is completely discharged from the cylinder, a small amount of steam passes from the cylinder into the water seal trap and from this point it is carried up through a pipe to the Thermostatic Motor chamber, causing the Thermostatic disc to expand and open a valve which permits the city water pressure to be exerted on the diaphragms of the steam and water valve simultaneously closing the steam and opening the water valve, thereby admitting water to the cylinder in the form of a SPRAY, condensing the steam or vapor contained therein, producing a vacuum—a very simple, economical and positive method.

Enormous Reserve Power. Thus, you see, an exceptionally high vacuum is produced almost instantly—and any experienced engineer will tell you that there is no greater or MORE POSITIVE method of producing a vacuum than by the condensation of steam when it is enclosed in an air tight cylinder such as we use in the manufacture of our pumps. Taking these facts into consideration, also the capacity of our different sizes of pumps, you will readily see that we have an enormous RESERVE POWER on hand to meet any and all emergencies.

Simple and Effective. While the water is entering the cylinder in the form of a spray, it is also admitted to the thermostatic motor for the purpose of cooling and reducing the pressure therein. When this is accomplished, the spring above the valve disc will automatically close the water valve.

The vacuum produced by the pump is sufficient at this point to hold the steam valve closed by its passing from the Pump Cylinder through small port holes in the Steam Valve bonnet to under side of diaphragm, holding it in a locked position with the steam and water valves closed.

ID 90-31034 TCF

The valves will remain closed until the vacuum in the cylinder drops to a point where the valves at which point the spring over steam valve discharge will release the valve and allow it to open, thereby permitting the steam to again enter the cylinder and drive the air pulled from the system by the previous stroke out through the discharge at the bottom. After the air is all discharged, steam will again enter the thermostatic motor, closing the steam valve and opening the water valve, allowing the pump to complete another stroke, as hereinbefore outlined.

The Power Plant. The Thermostatic Motor is the power plant of the pump—it gets its thermosatic action from the volatilization of a liquid contained in a number of metal discs with flexible walls.

The laws governing the volatilization of liquids are immutable and discs of this construction can always be relied upon to do the same work when operated under the same temperatures. The power produced by the discs is always in direct proportion to the temperatures to which they are subjected. This power is directed in such a manner as to make the upward and downward strokes of the pump **POSITIVE** and **QUICK**. Every movement is absolutely controlled by the Thermostatic Motor, insuring a positive action which is absolutely automatic and reliable in every way.

One of the big advantages of the Thermostatic Motor is that it is actuated by temperatures—the hot approach is through its contact with the motor, thereby creating sufficient pressure and power to instantly open the Hot Water Valve, closing the steam valve and opening the water valve simultaneously, permitting the water to enter the cylinder and the thermostatic motor at one and the same time, thus causing the condensing of the steam in the cylinder and the cooling of the thermostatic motor, thereby reducing the pressure and allowing the pump to close the valves.

Steam Power. The minimum steam pressure required to operate the pump is from one-quarter to one-half pound above the atmosphere. This pressure is only necessary when the pump is discharging. After the pump has produced a vacuum of twelve or fifteen inches and the pump system is reasonably tight, it may be some time before the pump will be called upon to make another stroke.

During this time, the entire heating system, including the boiler if the plant is operated low pressure, can be run under a vacuum. The only time that steam pressure is necessary is when the pump is discharging and then a slight pressure above the atmosphere is all that is required.

The pump will operate on any pressure from one-half pound to a maximum of ten pounds **Water Pressure.** The water pressure required for the pump varies from a minimum of ten pounds to a maximum of fifty pounds. If the city water pressure exceeds fifty pounds, there should be placed in the water supply to the pump, a pressure reducing valve to reduce the pressure to below fifty pounds.

A very important characteristic of the McALISTER Automatic Vacuum Pump and its fittings is that any other apparatus used for the same purpose is the fact that the pump continues to perform its work after the thermostatic motor has closed the steam and water valves. This is accomplished by the large cooling surfaces of the cylinder, which continues to condense any vapor steam that may remain therein, thereby increasing the vacuum and removing the air from the system long after the pump is apparently out of service.

Another characteristic of the McALEAR Pump is the powerful impulse or pull that each stroke has. This is so noticeable that in starting the plant in the morning, only a few strokes of the pump are necessary to entirely exhaust all the air from the heating system and to circulate steam through the farthest radiators and most remote parts of the plant as quickly as those nearest the pump and boiler. This is due, however, to the enormous capacity and displacement of the McALEAR Pumps. These pumps perform their work on large plants equally as well as on small, as the efficiency increases in proportion as the speed of operation decreases. This is accounted for by the exposed condensing surfaces of the cylinders, which can be readily demonstrated by closing the valve in the air-line connection at the pump, allowing it to make a stroke. When the stroke is completed, you will find that the pump has produced a vacuum of fifteen to eighteen inches and that this vacuum will continue to increase for a period of fifteen to twenty minutes after the steam and water valves are closed and the pump is apparently out of service.

It would be impossible to accomplish this with any other make of pump, as the vacuum produced would almost immediately disappear if the pump was shut down for a period of five or ten minutes. Thus, you will see why we claim such high efficiencies and low cost of operation. There is no other pump manufactured that has the capacity for handling and exhausting air in large volumes from a heating system as the McALEAR Pump. It is absolutely automatic, starting and stopping when needed and performing its work without the aid of outside power. It is the only pump in existence that has for its power plant a thermostatic motor actuated by the temperature of steam and water.

The McALEAR Automatic Vacuum Pump is positive and quick in action, simple and economical, and when in operation, does its work with eighty per cent less power than any other pump handling the same amount of air and doing the same work. It is adaptable to all kinds of steam-heating plants whether they be office buildings, public buildings, industrial plants or small residences. If parties interested will only investigate the different vacuum systems of heating now in use, they will be fairly convinced that we have the simplest and most effective vacuum-producing apparatus manufactured for the automatic removal of the air and water from a heating system.



Capacities and Prices of the McAlear Steam Vacuum Pumps

Number of Pump	Maximum Capac. in Sq. Ft. of Direct Radiation	Air Displacement of Pump in Cu. In. Per Stroke From No. Vacuum to 27 In.	Contents of Pump cylinders in Cubic Feet	Steam Consumption of Pumps in Pounds Per Stroke	PRICES
1	1000	6939	4.4	.1672	\$ 200
2	1800	9099	5.3	.2014	255
3	3000	9342	6.0	.2280	285
4	4400	13932	8.8	.3344	320
5	6000	15552	9.9	.3762	375
6	7800	17172	11.0	.4180	440
7	9800	18792	12.0	.4560	505
8	12200	20800	16.4	.6232	585
9	15200	25515	18.0	.6840	675
10	19500	31239	20.1	.7638	775
11	24500	33156	21.3	.8094	880
12	30000	35694	22.9	.8702	1000

Water consumption of pumps varies from 5 to 8 pounds per stroke, depending on size and amount of vacuum produced.

NOTE—Important.

In determining the proper size pump for the work please read the three paragraphs hereinafter outlined under heading "Basis for Determining the Proper Size Pump for the Work."

We will guarantee the satisfactory operation of our pumps only when connected with the radiation equal to or less than the maximum rated capacities given in the above table.

In ordering repair parts, refer to Engineer's Bulletin, which will be furnished on application.

We do not furnish any of the pipe connections or fittings shown in light lines on illustration, page 2, except the vacuum and steam gauges.

Basis for Determining the Proper Size Pump For the Work

If fan coils and direct radiation are used for heating and ventilating and the fan coil surface is given in lineal feet of one-inch pipe, reduce it to square feet and multiply by two, then add the direct radiation if there be any and the total will enable you to determine on the proper size pump.

If the fan coil surface is given in square feet of vento radiation, multiply by two and add the square feet of direct radiation, if there be any and the total will enable you to determine on the proper size pump.

If there are no fan coils, then take the square feet of direct radiation. If there is no direct radiation, take the fan coils or vento on the basis hereinbefore outlined.

Shipping Weight, Overall Dimensions and Size of Pipe Connections for the McAlear Vacuum Pumps.

No. of Pump	Weight	Height	Width	Steam	Water	Vapor	Discharge	Air Line
1	280	5'3"	2'0"	1 1/4	3/4	1 1/4	2"	1"
2	320	5'5"	2'2"	1 1/4	3/4	1 1/4	2"	1"
3	350	5'9"	2'2"	1 1/4	3/4	1 1/4	2"	1"
4	420	5'9"	2'6"	1 1/4	3/4	1 1/4	2"	1"
5	460	6'1"	2'6"	1 1/4	3/4	1 1/4	2"	1"
6	520	6'5"	2'6"	1 1/4	3/4	1 1/4	2"	1"
7	550	6'8"	2'6"	1 1/4	3/4	1 1/4	2"	1"
8	600	6'3"	3'0"	1 1/2	3/4	1 1/4	2"	1"
9	640	6'7"	3'0"	1 1/2	3/4	1 1/4	2"	1"
10	670	6'11"	3'0"	1 1/2	3/4	1 1/4	2"	1"
11	690	8'2"	3'0"	1 1/2	3/4	1 1/4	2"	1"
12	770	7'8"	3'0"	1 1/2	3/4	1 1/4	2"	1"

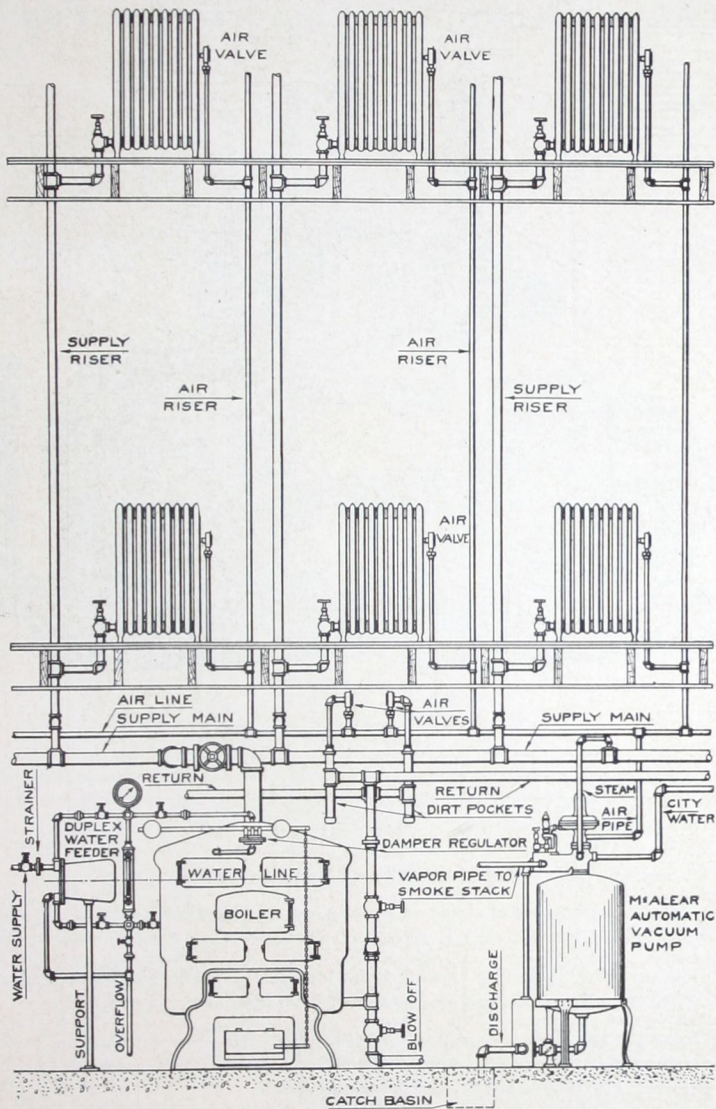

Method of installing the McAlear Air Line System of Vacuum Heating where water of condensation is returned to the boiler direct.

McAlear Electric Air Line Vacuum Pump

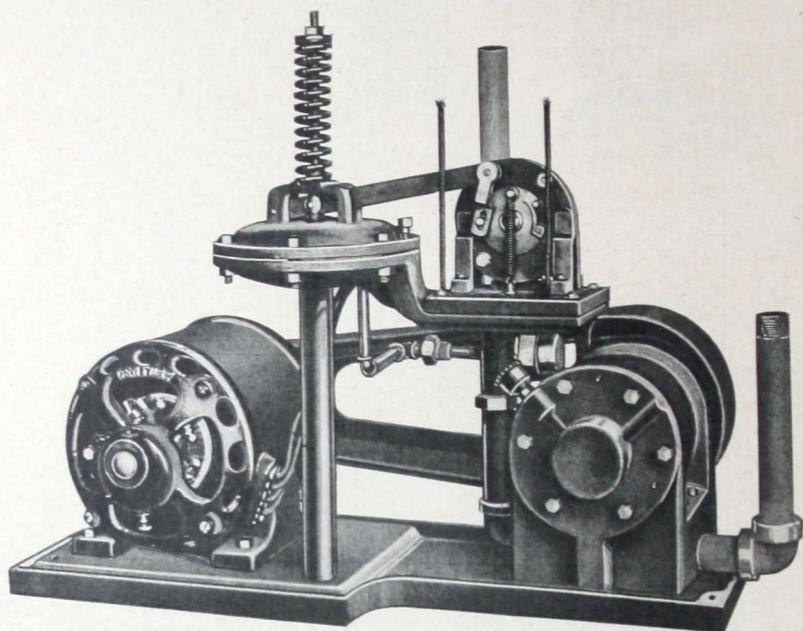

Exclusive Advantages

An important part of our system is the McAlear Electric Air Line Vacuum Pump of an entirely new and improved type of rotary design—with a single impeller which rotates on ball bearings displacing the air with a rolling motion, eliminating all friction and rubbing surfaces. When in operation neither air or water is required to seal these pumps—there are no valves, gears, pistons, or sliding contacts requiring take-up or adjustment.

The pump and motor are mounted on a heavy cast iron base in the form of one simple and compact unit—the belt is endless, oak tanned and impervious to steam, water or acids.

We guarantee the satisfactory working of these pumps—each pump is thoroughly tested before leaving our factory—all bearings are carefully lubricated, ready for operation.

No other electric pump is so well adapted for use in connection with air line vacuum heating systems for residence, apartment buildings, hotels, office buildings, schools and other public buildings, including large stores and industrial plants.

The pumps are silent in operation. They are provided with an automatic vacuum controller, so arranged that when the vacuum drops to three inches on the air line, the motor automatically starts the pump and immediately runs the vacuum up to 5 or 8 inches, at which point the current is automatically cut off and the pump is shut down.

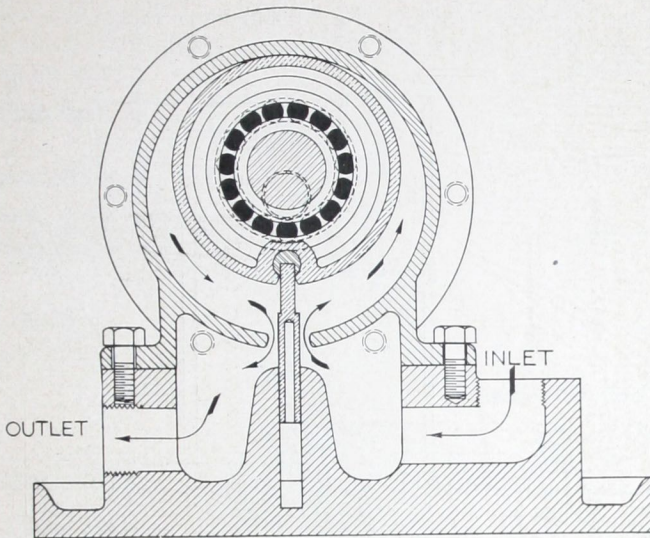

1. Impeller. 3. Ball bearings. 5. Inlet.
 2. Crank shaft. 4. Hinged Wall. 6. Discharge.

Capacities and Prices of the McAlear Electric Air Line Vacuum Pumps

No. of Pump	Max. Cap. Sq. Ft. Direct Radiation	Horse Power of Motor	Actual Dis- pac't cu. ft. Per Minute	Space Req'd for Pump Inches	List Price	Approx. Shipping Weight
10	4000	12x22	\$353.14	300
11	6000	1/4	6	12x22	411.90	350
12	10000	1/3	10	12x24	555.06	450
13	20000	1/2	20	14x30	891.00	550
14	28000	3/4	35	14x30	990.00	700
15	35000	14x36	1,126.40	800

In ordering pumps be sure to state whether the current is direct or alternating, giving the voltage, cycle, and phase.

We will guarantee the satisfactory operation of our pumps only when used in connection with the radiation set opposite each size in the above table. In ordering pumps, please state the amount of radiation in square feet of direct radiation and square feet of blast coil or vento radiation, if there be any. The above capacities are based on square feet of direct radiation only.

In order to determine the size pumps for blast coil work, multiply the square feet of blast coil or vento radiation by two and select a pump suitable for the work.

The above prices include pump and motor complete with sub-base, expansion tank, gauge glass, 3 1/2" vacuum gauge, automatic electric vacuum controller and check valve in air connection between the expansion tank and pump.

All materials delivered f. o. b. cars, Chicago.

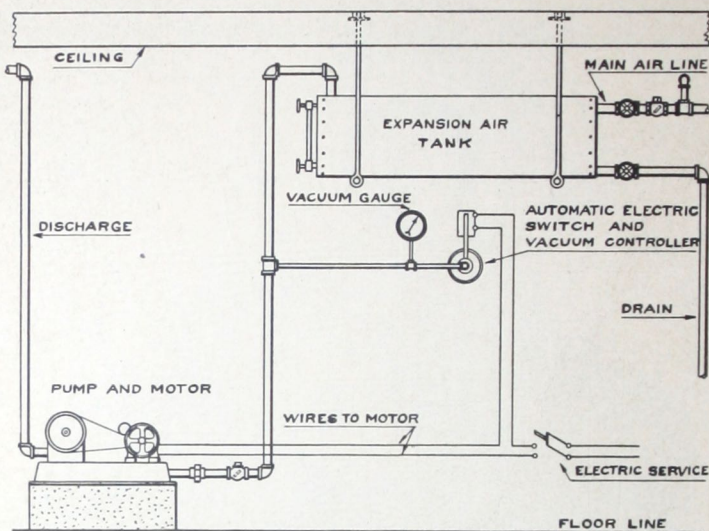

For Old or New Heating Plants

For description of the air piping system ask for complete specification which will be sent you on request.

The McAlear Electric Vacuum Pumps can be installed in connection with old or new heating plants, having what is known as a one or two pipe system. When installed in connection with plants already in operation, the air piping is usually run to correspond to the steam piping and the connections to the radiators are made to an automatic air valve that is usually placed about midway the radiator.

When installing the air piping system, care should be taken to ream out the pipes and see that all joints are made properly and that they are put together with asphaltum so as to make them absolutely air tight.

When the air piping is installed, a test should be made as prescribed in our complete air piping specifications.

If the air piping is properly installed and will stand the test prescribed, the pump will be able to produce 5 to 10 inches of vacuum in 10 or 15 minutes from the time the service switch automatically starts the motor and pump. This vacuum will be sufficient to exhaust the air from the radiators and discharge it to the atmosphere. When the air is all exhausted and the vacuum reaches 6 or 8 inches, the automatic electric vacuum controller cuts off the current and shuts the pump down. The pump will remain shut down until the vacuum on the air line drops to five inches, at which point the automatic vacuum controller throws the controlling switch and starts the pump and again brings the vacuum up to the required point where the current is again cut off and the pump closes down. In operating the pump automatically in this manner it reduces the cost of operation to a minimum, and increases the life of the pump and motor.

The actual cost of operating the pump amounts to only a few cents per day for the electric current used.

McAlear Thermo Vent Automatic Air Valve

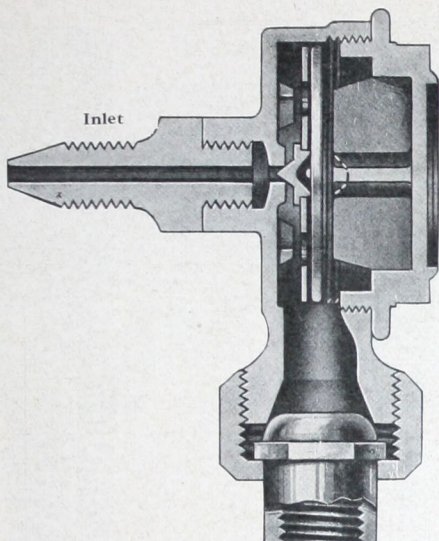

No. 22

No Adjusting—"Fool-Proof"

The $\frac{1}{4} \times \frac{1}{8}$ inch Thermo Vent Automatic Air Valves are used in connection with the McAlear System of Vacuum Heating or any other air line vacuum or drip pipe work. Because of their design and construction, no adjustment is necessary either at the factory or on the job. This is an important advantage because it insures perfect operation of the system and hot radiators at all times. Contractors and Engineers will appreciate this advantage as it eliminates the trouble and expense so often experienced in having to adjust and put in order the so-called "automatic" air valves formerly used for this purpose.

The McAlear Thermo Vent Automatic Air Valves are "fool proof"—they cannot be tampered with or put out of order. Each valve is provided with a movable hex nipple No. 1 so that if one should happen to break when connecting the valve to the air lines and radiators, all the expense incurred to make the valve as good as new would be a few cents for another nipple. The McAlear is superior to all other valves in this respect. If this nipple should break on any other make of valve, the valve would have to be thrown into the scrap heap at a total loss to the purchaser because it could not be repaired.

In addition, the McAlear has another decided improvement over all other makes of valves. A hex tail piece No. 6 is used, which enables the steam fitter to screw it on to a pipe with a monkey wrench, thus preserving the nickel plating with no possibility of marring the appearance of the valve.

(For prices, see page 12)

McAlear Thermo Vent Automatic Air Valves

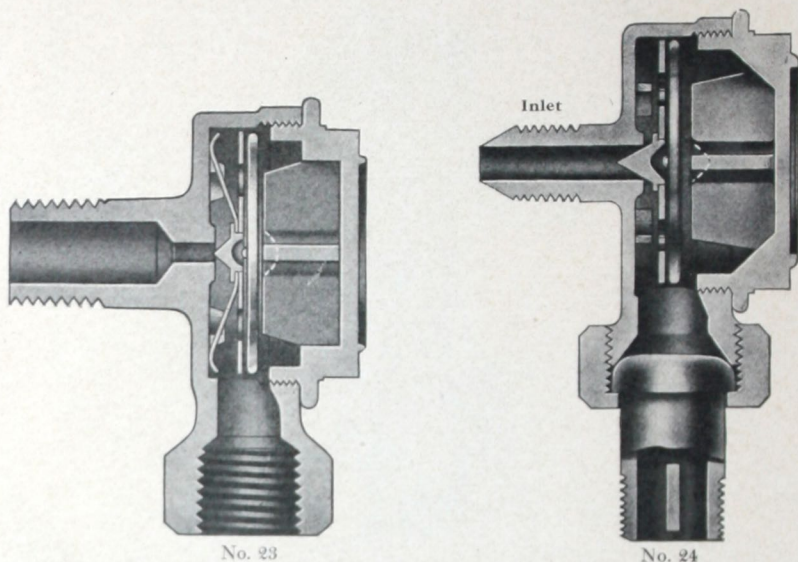

The McAlear Thermo Vent Automatic Air Valves are recommended for use in connection with Fan Coils, Vento Radiation and the McAlear System of vacuum heating, as they are necessary to insure its perfect and successful operation.

We do not hesitate to unqualifiedly guarantee these valves to be perfect in design, workmanship and material, and to be absolutely automatic and non-adjustable, also to pass air in large quantities and to close absolutely tight against steam, whether used in connection with gravity or vacuum heating systems. It is understood that when these valves are used in connection with gravity or vacuum heating systems they are to be provided with drip pipes.

All air valves for high steam pressures are made to order at a small additional cost. In ordering, state service and pressures.

No. 22, Size $\frac{1}{4} \times \frac{1}{8}$ "	\$2.50 each
No. 23, Size $\frac{3}{8} \times \frac{3}{8}$ "	3.50 each
No. 24, Size $\frac{3}{8} \times \frac{1}{2}$ "	5.00 each
No. 26, Size $\frac{1}{2} \times \frac{1}{2}$ "	6.00 each

Liberal discounts from above prices will be given to the trade.

McAlear Thermo Vent Automatic Air Valve

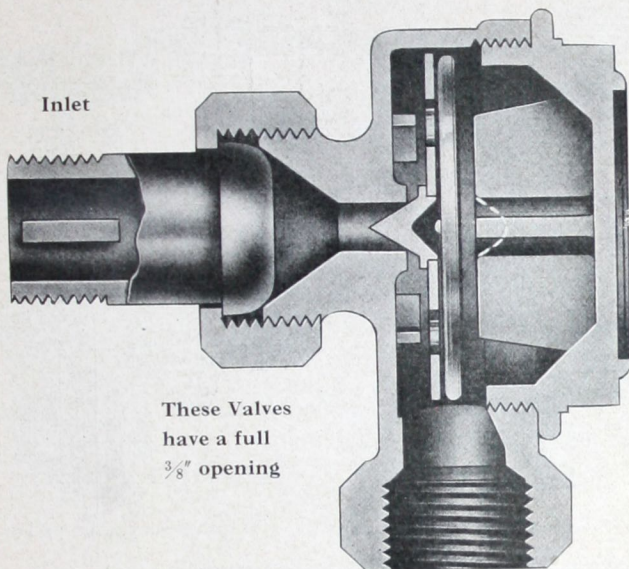

Actual Size
No. 26

These Valves
have a full
 $\frac{3}{8}$ " opening

Self-Cleaning—Self-Protecting

The McAlear Thermo Vent Automatic Air Valves are the result of years of experience and represent the highest degree of engineering and inventive efficiency. They never require any adjustments and are sealed so that it is impossible for anyone to tamper with them in any way. They are positive in action and absolutely noiseless in operation.

The non-adjustable advantage is worthy of your serious consideration because it relieves the contractor of the responsibility, trouble and expense of adjusting the valves after they are in operation. **This means a worth while saving in money, time and labor to the contractor, as well as the owner—and it also insures perfect service—a perfect circulation of steam and is a guarantee of hot radiators at all times under any and all conditions.**

These McAlear Air Valves are also self-cleaning and the expansion discs are self-protecting. We furnish these valves for use in connection with high pressure steam plants as well as for low pressure vacuum heating systems.

In ordering valves for high pressure steam service, always state the initial pressures as we furnish special discs suitable for any pressure up to and including 125 pounds. Therefore, clearly state the service and pressure that the valve is to operate in connection with.

(For Prices see Page 12)

McAlear Packless Radiator and Graduating Valves

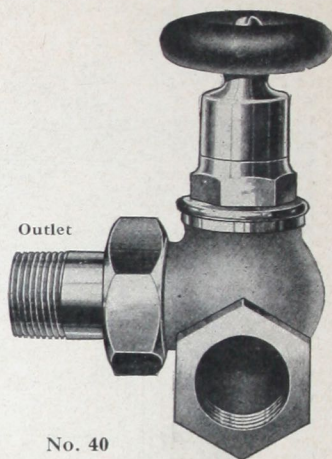
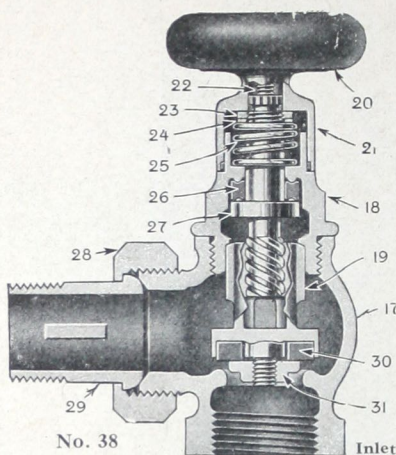

These valves are constructed of the best steam metal with special composition packless discs.

Valves are quick opening and are made in all sizes graduated with either lever or wood wheel handles. See Bulletin D for prices, etc.

Where valves are placed behind grill work, special handles are provided at an additional nominal cost.

Lock Shield Attachments and keys are provided at a small additional cost.

PRICES AND DIMENSIONS No. 38

Size, inches	1/2	3/4	1	1 1/4	1 1/2	2
Rough Body Plated all over	\$4.00	\$4.00	\$4.80	\$6.40	\$8.35	\$13.50
Face of outlet to center of inlet	2 1/4	2 13/16	3 1/2	3 1/2	4	4 5/16
Face of inlet to center of outlet	1 3/16	1 3/8	1 5/8	1 3/4	1 15/16	2 3/8

PRICES AND DIMENSIONS No. 40

Size, inches	1/2	3/4	1	1 1/4	1 1/2	2
Rough Body Plated all over	\$4.16	\$4.16	\$5.05	\$6.80	\$8.50	\$14.00
Center to face of inlet	1 3/16	1 11/16	1 13/16	2 1/16	2 3/8	2 3/4
Center to end of outlet	2 3/8	2 7/8	3 5/8	3 5/8	4	4 3/8
Center inlet below center of outlet	1/2	5/8	3/4	7/8	1 1/2	1 3/4

Liberal discounts will be given on application.

The McAlear Vapor Regulator

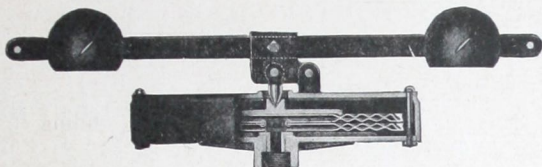

No. 56

The McAlear Regulator is very sensitive and absolutely positive and reliable in operation, and will control boiler pressure in ounces. That is, it will maintain any pressure in ounces desired with but a slight variation from the point at which the regulator is set to operate.

The regulator will not control dampers and check drafts when operating the boiler and heating system under a vacuum, as the dampers are wide open when such conditions prevail. However, any boiler pressure above the atmosphere can absolutely be controlled in ounces of pressure with this regulator.

CONSTRUCTION

The best quality of special bronze metal of the proper thickness and tension is used in the construction of the bellows, which makes them very durable and sensitive to the slightest variation in pressure.

The bellows is 12 inches in diameter, constructed of four flexible walls which gives the required travel of $\frac{1}{2}$ inch without causing any strain whatsoever on any of its parts. This $\frac{1}{2}$ inch travel, when distributed over the four flexible walls is only an expansion of $\frac{1}{8}$ inch for each wall—which is less than 100 per cent of what each wall will actually expand with safety.

WORKING PRESSURES

The Vapor Regulator must not be used on steam pressures above three pounds. The vacuum produced by the boiler and heating system will not injure the disc in any way as the flexible walls lay absolutely up against each other when the boiler and heating system goes to a vacuum.

SHIPPING WEIGHT, 40 POUNDS—PRICE COMPLETE, \$30.00

The McAlear Steam Pressure Regulator

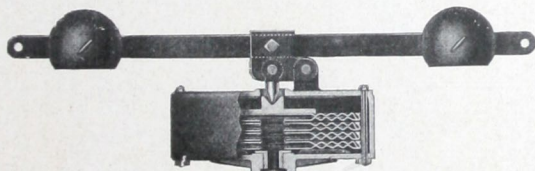

No. 58

The Pressure Damper Regulator will operate on the slightest variation in pressure and will control the boiler pressure within a quarter pound of that required by simply moving the weight on the lever in or out as the case may be until you have reached the pressure that you wish to control, and when this is done, fasten the weights to the lever with the thumb screw permanently.

CONSTRUCTION

The construction of the McAlear Pressure Damper Regulator is practically the same as the Vapor Regulator No. 56. The only difference being in the bellows, which are made up of four 8-inch discs, in place of two 12-inch. In all other respects the material and construction is the same in every way.

WORKING PRESSURES

The Pressure Regulator No. 58 is suitable for a maximum working pressure of 20 pounds and will operate successfully from 20 pounds down to zero. They are very sensitive, durable and absolutely reliable, and will control the boiler pressure with one-fourth pound of that required when properly installed and regulated.

SHIPPING WEIGHT, 23 POUNDS—PRICE COMPLETE, \$20.00

EQUIPMENT

The McAlear Regulators No. 56 and No. 58 are tapped for a 1-inch steam pipe connection and shipped complete with levers and two weights, together with the necessary S hooks, two ceiling pulleys and 12 feet of No. 10 tinned chain.

McAlear Specialties

BULLETIN "A" VACUUM HEATING SYSTEM.

BULLETIN "B" VAPOR HEATING SYSTEM.

BULLETIN "C" AIR LINE HEATING SYSTEM.

BULLETIN "D" FULL LINE of PACKLESS RADIATOR and GRADUATING VALVES

BULLETIN "E" HIGH and LOW PRESSURE STEAM TRAPS.

CATALOGUE No. 25—HEATING POWER and PLUMBING SPECIALTIES.

Pressure Regulating, Relief and Retaining Valves for Steam.

Water, Air and Gas Pressure Regulating Valves, Altitude and Altitude Relief Valves and Float Valves for Controlling Water in Tanks.

Pressure Controlling Devices: Pressure Pump Governors, Vacuum Water Jet Controllers, Suction Strainers, Drip Tank Controllers, Condensation Receivers, Fan Engine Regulators, Balance Valves, Valve Controllers, Excess Pressure Pump Regulators, High Pressure Boiler Water Line Governors, Damper Regulators and Hot Water Temperature Controllers.

Boiler Stop and Check Valves.

Back Pressure and Atmospheric Relief Valves and Exhaust Heads.

Steam and Grease Separators and Muffler Tanks.

Steam and Grease Traps, Trap Strainers, Return Traps, Pump Traps, Vacuum Traps, and Water Line Traps.

Automatic Water Feeders for Low Pressure Boilers.

Strainers for Regulating Valves, Pressure Controlling Devices and Water Feeders.

Diaphragms.

Companion Flanges and Bolts.

The McAlear Mfg. Co.

1901-7 S. Western Avenue

Chicago