

INSTALLATION INSTRUCTIONS

Observer Zoning Board ZONE0101ZP6

These instructions must be read and understood completely before attempting installation

Safety Labeling and Signal Words

DANGER, WARNING, CAUTION, and NOTE

The signal words **DANGER**, **WARNING**, **CAUTION**, and **NOTE** are used to identify levels of hazard seriousness. The signal word **DANGER** is only used on product labels to signify an immediate hazard. The signal words **WARNING**, **CAUTION**, and **NOTE** will be used on product labels and throughout this manual and other manual that may apply to the product.

DANGER – Immediate hazards which will result in severe personal injury or death.

WARNING – Hazards or unsafe practices which could result in severe personal injury or death.

CAUTION – Hazards or unsafe practices which may result in minor personal injury or product or property damage.

NOTE – Used to highlight suggestions which will result in enhanced installation, reliability, or operation.

Signal Words in Manuals

The signal word **WARNING** is used throughout this manual in the following manner:

 **WARNING**

The signal word **CAUTION** is used throughout this manual in the following manner:

 **CAUTION**

Signal Words on Product Labeling

Signal words are used in combination with colors and/or pictures or product labels.

 **WARNING**

PERSONAL INJURY, AND/OR PROPERTY DAMAGE HAZARD

Failure to carefully read and follow this warning could result in equipment malfunction, property damage, personal injury and/or death.

Installation or repairs made by unqualified persons could result in equipment malfunction, property damage, personal injury and/or death.

The information contained in this manual is intended for use by a qualified service technician familiar with safety procedures and equipped with proper tools and test instruments.

Installation must conform with local building codes and with the national Electrical Code NFPA70 current edition or Canadian Electrical Code part 1 CSA C.22.1. The National Fuel Gas Code (NFGC) NFPA 54/ANSI Z223.1, and in Canada refer to the current editions of the National Standards of Canada CAN/CSA-B149.1 and .2 Natural Gas and Propane Installation codes.

 **WARNING**

ELECTRICAL SHOCK HAZARD

Failure to follow this warning could result in personal injury or death.

Before installing or servicing system, always turn off main power to system and install lockout tag. There may be more than one disconnect switch.

 **CAUTION**

CUT HAZARD

Failure to follow this warning could result in personal injury.

When removing access panels or performing maintenance functions inside your unit, be aware of sharp sheet metal parts and screws. Although special care is taken to reduce sharp edges to a minimum, be extremely careful and wear appropriate clothing, safety glasses, and gloves when handling parts or reaching into the unit.

NOTE: Read the entire instruction manual before starting the installation.

SAFETY CONSIDERATIONS

Improper installation, adjustment, alteration, service maintenance, or use can cause explosion, fire, electrical shock, or other conditions which may cause death, personal injury, or property damage. Consult a qualified installer, service agency, or your distributor or branch for information or assistance. The qualified installer or agency must use factory-authorized kits or accessories when modifying this product. Refer to the individual instructions packaged with the kits or accessories when installing.

Follow all safety codes. Wear safety glasses, protective clothing, and work gloves. Have a fire extinguisher available. Read these instructions thoroughly and follow all warnings or cautions included in literature and attached to the unit. Consult local building codes, the current editions of the National Fuel Gas Code (NFGC) NFPA 54/ANSI Z223.1, and the National Electrical Code (NEC) NFPA 70.

In Canada refer to the current editions of the National Standards of Canada CAN/CSA-B149.1 and .2 Natural Gas and Propane Installation codes, and Canadian Electrical Code CSA C22.1

Recognize safety information. This is the safety-alert symbol . When you see this symbol on the unit and in instructions or manuals, be alert to the potential for personal injury. Understand these signal words: DANGER, WARNING, and CAUTION. These words are used with the safety-alert symbol. DANGER identifies the most serious hazards which **will** result in severe personal injury or death. WARNING signifies hazards which **could** result in personal injury or death. CAUTION is used to identify unsafe practices which **may** result in minor personal injury or product and property damage. NOTE is used to highlight suggestions which **will** result in enhanced installation, reliability, or operation.

INSTALLATION CONSIDERATIONS

Before the actual installation of a zoning system can begin, decisions need to be made to determine the number and location of zones and sensors. This affects duct and damper selections. This instruction covers the physical installation and start up of the Observer Zoning Board. Use this instruction to guide the actual installation process after all the air side decisions have been made. One Zoning Board is capable of handling up to four zones of operation. When greater than four zones are required, a second Zoning Board Module is needed for zones 5 through 8 (8 zones maximum).

1. Install the Observer Zone Control (User Interface) and Remote Room Sensors in non-condensing areas with ambient temperatures between 32° F. and 120° F. Install Dampers and Observer Zoning Board in non-condensing areas with ambient temperatures between -4° F. to 158° F., (-20° to 70° C).
2. A TXV is required on the indoor coil when used with all residential split system equipment.
3. Proper equipment selection and duct sizing are important in a zoned system.
4. Either a barometric bypass or a powered damper used as a dump zone may be used with the Observer Zoning System. Sizing of the bypass duct should be selected so that a maximum of X% is allowed to bypass into the return duct. Excessive bypass can cause equipment short cycling and reduce equipment life.

INSTALLATION

STEP 1—CHECK EQUIPMENT AND JOB SITE

INSPECT EQUIPMENT — File claim with shipping company, prior to installation, if shipment is damaged or incomplete.

STEP 2—COMPONENT LOCATION AND WIRING CONSIDERATIONS

WARNING

ELECTRICAL SHOCK HAZARD

Failure to follow this warning could result in personal injury or death.

Before installing or servicing system, always turn off main power to system and install lockout tag. There may be more than one disconnect switch.

Disconnect supply power before routing wire.

NOTE: All wiring must comply with national, local, and state codes.

Locating Observer Zoning Board

NOTE: All wiring is run back to the Observer Zoning Board.

All system wiring is run back to the Observer Zoning Board. Select a location near the Observer furnace or fan coil where wiring from the Observer wall control, each Remote Room Sensor or CTS Sensor, each damper actuator, and the equipment itself can come together easily.

The Observer Zoning Board is approved for indoor use only and should never be installed with any of its components exposed to the elements. The Observer Zoning Board (and the zone dampers) may be installed in any area where the temperature remains between -4° F. to 158° F. (-20° C to 70° C), and where there is no condensation. The cover must be installed to prevent damage from other sources. Do not locate where it will be accessible to children.

It may be mounted in either vertical or horizontal position. Remember that wiring access is likely the most important consideration.

CAUTION

ELECTRICAL OPERATION HAZARD

Failure to follow this caution may result in damage to the unit or improper operation.

To prevent possible damage to the Observer Zoning Board, do not mount on plenum, duct work, or flush against furnace.

LOCATING Observer Wall Control

The Observer Wall Control is the command center for the Observer Zone System. It should be located where it is easily accessible and visible to the home or business owner. It is the Zone 1 sensor and as such needs to be located to properly measure the temperature in Zone 1.

If it cannot be installed in the zone 1 space, a separate Remote Room Sensor can be added for Zone 1 by connecting it to the S1 and S2 terminals on the Observer CTS back plate.

NOTE: The Observer Wall Control also controls humidity functions. If the User Interface is not used to control Zone 1 temperature, it must still be located in a suitable area where humidity control will not be affected.

LOCATING SENSORS

For proper operation, each sensor must accurately measure the temperature within its zone. For accurate temperature measurement, the following guidelines should be followed:

Sensor should be mounted:

- Approximately 5 ft. (1.5m) from floor.
- Close to the center of its zone, preferably on an inside wall.
- On a section of wall without pipes or ductwork.

Sensor should NOT be mounted:

- Close to a window, on an outside wall, or next to a door leading to the outside.
- Where it will be exposed to direct light and heat from a lamp, sun, fireplace, or other temperature radiating object which may cause a false reading.
- Close to or in direct airflow from supply registers.
- In areas with poor air circulation, such as behind a door or in an alcove.

WIRING CONSIDERATIONS

Ordinary thermostat wire is ideal when wiring the Observer Zoning System (shielded cable is not typically necessary). Use 22 AWG or larger for typical installations. Lengths over 100 ft. should use 20 AWG or larger wire. Zone sensors require 4 conductors to be run. A CTS Zone Sensor may replace the Remote Room Sensor with no wiring changes at a later date. The Observer Wall Control requires 4 conductors, each damper actuator requires either 2 or 3 conductors. Cut off or fold back and tape any unneeded wires. Plan the routing of wiring early to avoid possible problems later. Sometimes, it is a good idea to run conduit in hard to access locations, in case a new wire must be pulled at a later date. Remember, all wires converge at the Observer Zoning Board, so its location is important.

NOTE: Wiring of the communication bus only requires a four wire connection; however, it is good practice to run thermostat cable having more than four wires in the event of a damaged or broken wire during installation.

The following color code is recommended for each ABCD bus connection:

- DX+ — Green = Data +
- DX- — Yellow = Data -
- C — White = 24 VAC (Com)
- R — Red = 24VAC (Hot)

It is not mandatory that the above color code be used, but each bus connection in the system **MUST** be wired consistently.

STEP 3—INSTALL COMPONENTS

INSTALL Observer Zoning Board

The Observer Zoning Board is designed so that wires can enter it from behind, above, or below. Plan wire routing before mounting Damper Control.

1. Open cover to access mounting holes.
2. Mount back plate to wall using screws and wall anchors provided.
3. Level back plate and tighten screws.

INSTALL Observer Wall Control — (see Observer Wall Control Installation Instructions for details).

NOTE: Improper wiring of the green communication bus connector will cause the Observer Zoning System to operate improperly and/or fail to communicate. Check to make sure all wiring is correct before proceeding with installation or turning on power.

Fig. 1 – Zoning Board and Remote Sensors



ZONING BOARD

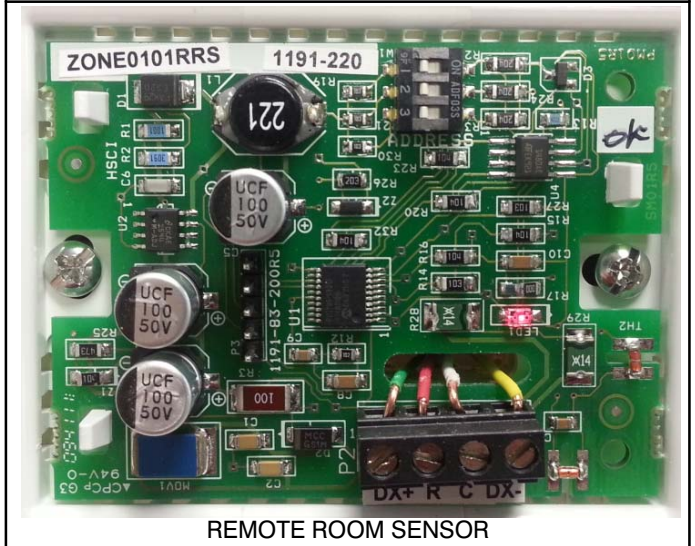

REMOTE ROOM SENSOR

INSTALL Remote Room Sensors

1. Separate the sensor cover and mounting back plate by squeezing the top and bottom of the cover together firmly by grasping the raised top and bottom ridges. This will release the cover. Mount to wall using provided screws and anchors.
2. Pull a 4-conductor wire through hole on right-hand side.
3. Recommended connection is:

- DX+ — Green = Data +
- DX- — Yellow = Data -
- C — White = 24 VAC (Com)
- R — Red = 24VAC (Hot)

Stranded or common bell wire may be used. Lengths up to 100 ft. are acceptable.

4. Push any extra wire into wall and seal hole to prevent air leaks. Align sensor cover with base plate then press firmly until cover snaps into place.

The Observer Wall Control and Zone Sensors should be wired to the appropriate terminal connectors on the Observer Zoning Panel. 18-22 Gauge wire should be used. If the low-voltage wiring must be run alongside line voltage wiring or near fluorescent lighting or other electrically noisy devices, shielded cable should be used and grounded at the common terminal on

one end). The dip switch on each OBSERVER Zone Sensor should be selected for the appropriate zone number; for instance, Zone 2 sensor should be selected using the DIP switch for 'off, off, off'.

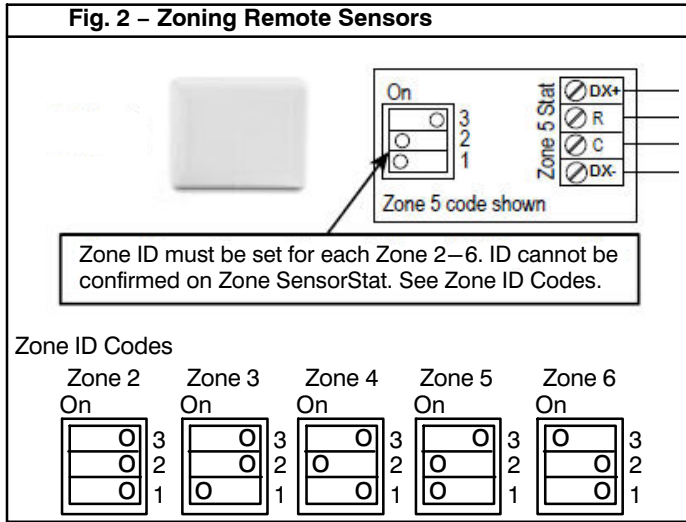

STEP 4—INSTALL ZONE DAMPERS

Proper selection and sizing of dampers is very important for proper system operation. Be sure to consult the Damper Product Data Digest for assistance in making these selections. Selection and sizing information is not provided in this installation instruction. Zone dampers are available in round and rectangular and may be installed in any position. Install dampers so that actuator is visible for inspection and accessible in the event it would need to be serviced. The black mark on the end of the damper shaft represents position of damper blade. To wire damper, locate terminals labeled: OPN (open); COM (common); CLS (closed; and wire appropriately (see Fig. 1 for Damper 24 VAC connection).

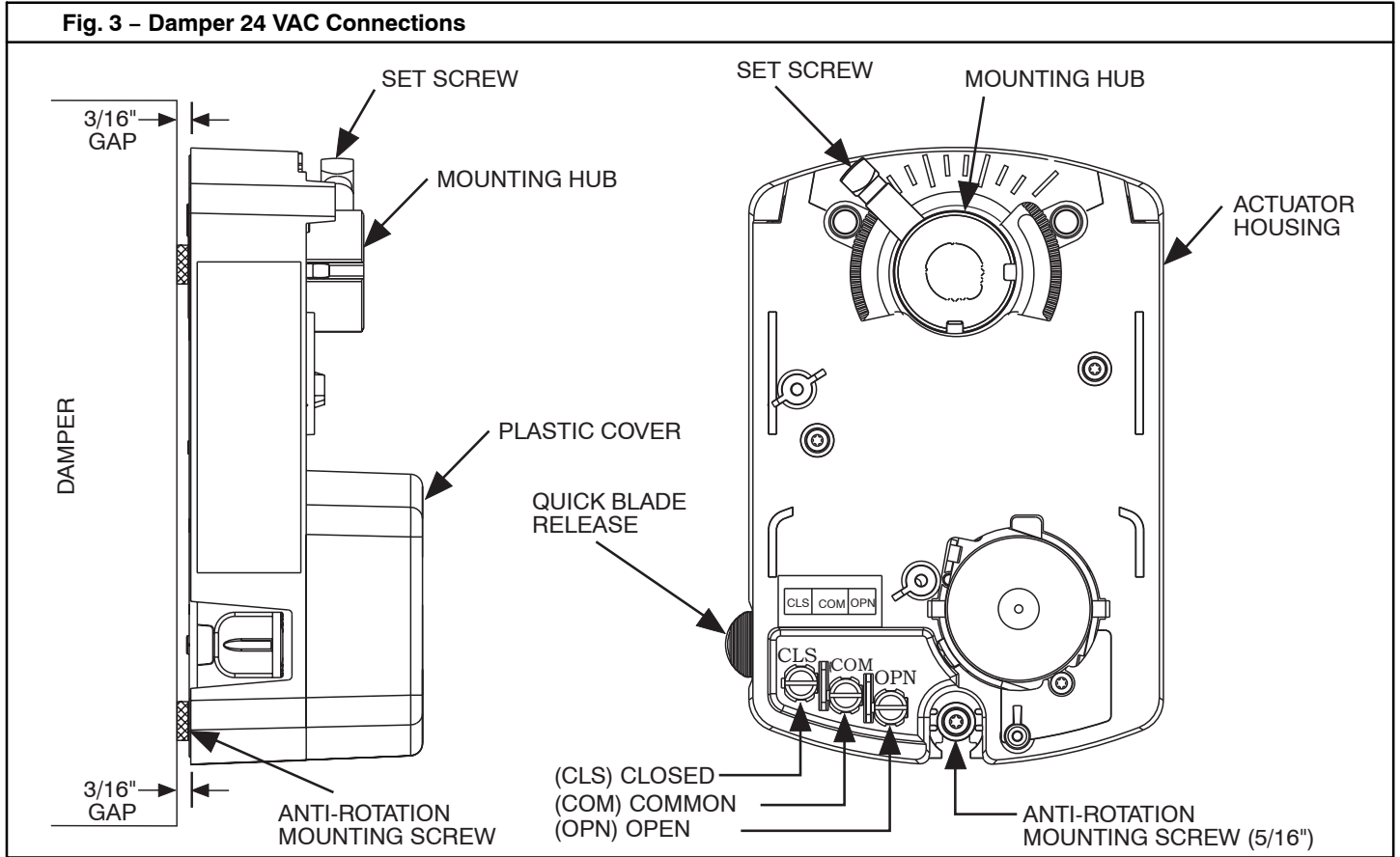

If duct system requires multiple dampers for a single zone, up to 3 dampers (maximum) may be wired in parallel. For all applications, including retrofit, it is recommended to use only current dampers with direct-drive style actuators. **DO NOT** use older damper with crank-arm style actuators.

If an actuator is removed from a damper for any reason, it must be properly aligned when it is reinstalled. This can be done by rotating the actuator and the blade to their closed positions and then tightening the actuator (set screw) to the shaft. This assures alignment at the closed position. (Pressing the quick blade release button allows the actuator to be manually turned).

⚠ CAUTION
ELECTRICAL OPERATION HAZARD

Failure to follow this caution may result in damage to the unit or improper operation.

Condensation can damage the actuator. When dampers are located in an unconditioned space, condensation is likely to occur in cooling. To prevent condensation and losses, all dampers and ductwork in unconditioned space must be insulated or otherwise protected.

For specific duct types, follow instructions below:

NOTE: All zone dampers and ductwork must be properly supported according to local codes or SMACNA standards.

ROUND METAL DUCTWORK

1. Crimp end of branch duct.
2. Slip end of zone damper over end of ductwork. Use selftapping sheet metal screw to secure.
3. Properly seal joint using duct tape, mastic, or other approved method. Do not allow mastic to come in contact with actuator.
4. If dampers are applied in an unconditioned space, insulate damper using 1-1/2 inch to 2 inch insulation (See Fig. 4).

Fig. 4 – Insulated Round Metal Ductwork

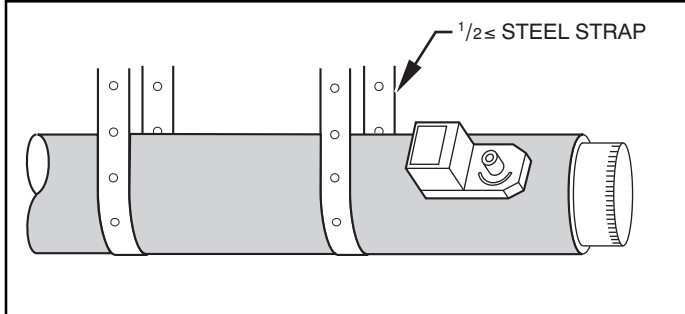

RECTANGULAR DUCTWORK

1. Make connections using S-lock and drives (See Fig.5).
2. Properly seal joint using duct tape, mastic, or other approved method. Do not allow mastic to come in contact with actuator.
3. If dampers are applied in an unconditioned space, insulate damper using 1-1/2 inch to 2 inch insulation (See Fig. 6).

Fig. 5 – Rectangular Ductwork

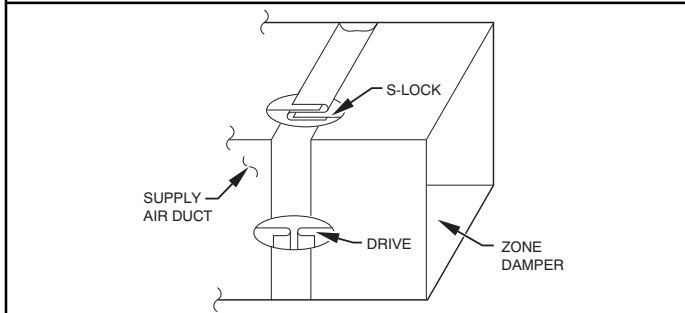
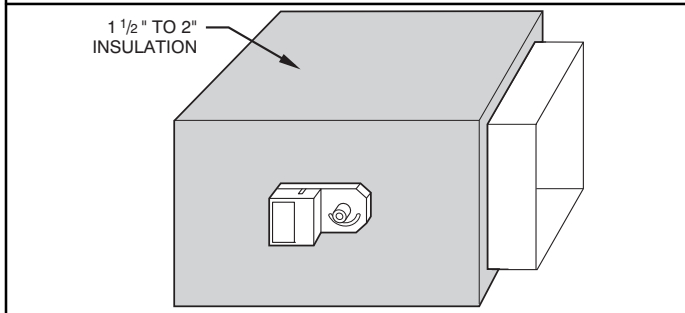

Fig. 6 – Insulate Damper



ROUND FLEXIBLE DUCTWORK

1. Slip one end of flexible ductwork over end of zone damper (See Fig. 7).
2. Secure flexible duct to zone damper using SMACNA or other approved method.
3. Properly seal joint using duct tape, mastic, or other approved method. Do not allow mastic to come in contact with actuator.

4. If dampers are applied in an unconditioned space, insulate damper using 1-1/2 inch to 2 inch insulation (See Fig. 8).

Fig. 7 – Round Flexible Ductwork

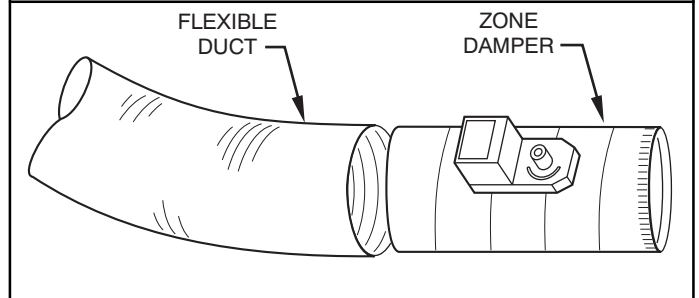
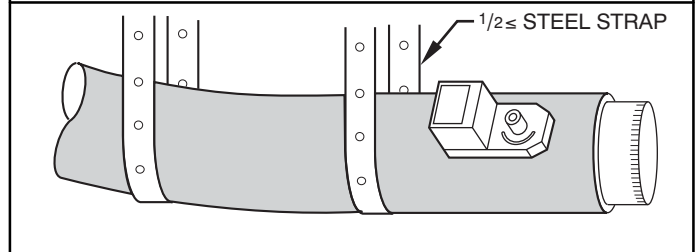

Fig. 8 – Insulate Ductwork



RECTANGULAR FIBROUS GLASS DUCTWORK

1. Insert one end of zone damper into end of fibrous glass ductwork approximately 2 to 3 inches (See Fig. 9).
2. Use field supplied screws to secure duct board to zone damper.
3. Properly seal joint using duct tape, mastic, or other approved method. Do not allow mastic to come in contact with actuator.
4. If dampers are applied in an unconditioned space, insulate damper using 1-1/2 inch to 2 inch insulation (See Fig.10).

Fig. 9 – Rectangular Fibrous Glass Ductwork

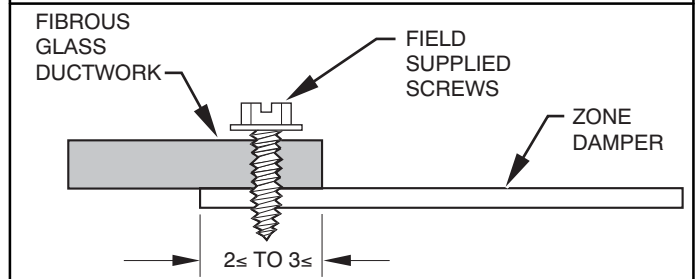
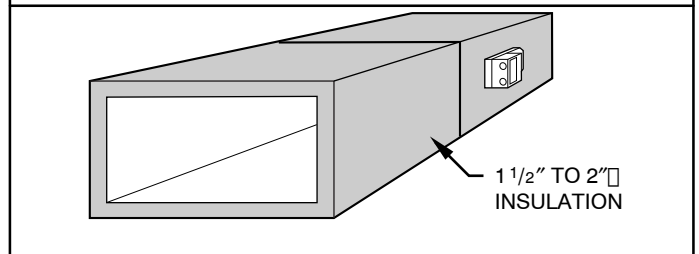

Fig. 10 – Insulated Rectangular Fibrous Glass Ductwork



STEP 5—FINAL WIRING

Bring all damper and sensor wires together at the Observer Zoning Board. Make all system wiring connections as indicated in Fig. 11.

The two DX+DX-R C bus connections on the Observer Zoning Board are in parallel with each other. Use either terminal block to connect the Zoning User Interface, Room Remote Sensor(s), variable-speed indoor unit and 2-speed communicating outdoor

unit (if applied). If more than four zones are required (up to 8 zones maximum), see Step—6 and Fig. 10 for Additional Zoning Board Board Setup for Zones 5-8.

LEAVING AIR TEMPERATURE SENSOR

The LAS input on the Observer Zoning Board is used to protect the equipment from very high or very low leaving air temperatures. The equipment will be cycled off if the temperature is less than 180°F or more than 45°F. The equipment will cycle back on when the temperature is above 45° F and below 180°F and after 15 minutes have passed. The heating and cooling LAS limits are adjustable. See the Observer control installation instructions for more information.

LED INDICATORS

Under normal operation, the Yellow and Green LEDs will be on continuously (solid). If the Observer Damper Control does not receive communications with the User Interface, the Green LED will not be on. If there are faults present, the Yellow LED indicator will blink a single-digit status code. It will blink at a fast rate, pause, then repeat.

FUSE

A 5-amp automotive type fuse is used to protect the Observer Zoning Board from over current on the damper drive outputs. If this fuse fails, damper wiring should be inspected for shorts. Also, no more than five damper motors should be connected to a single damper output. Fuse should always be replaced with an identical 5 amp automotive fuse.

STEP 7—Transformer Requirements

The Observer Zoning System requires its own 75VA transformer to power the dampers. Use of the transformer provided in the furnace or fan coil is NOT recommended.

STEP 8—System Start-Up

Follow the system start-up process outlined in the Observer Zone Control Installation Instructions for details.

On initial power up, the Observer Wall Control will display the following screen.

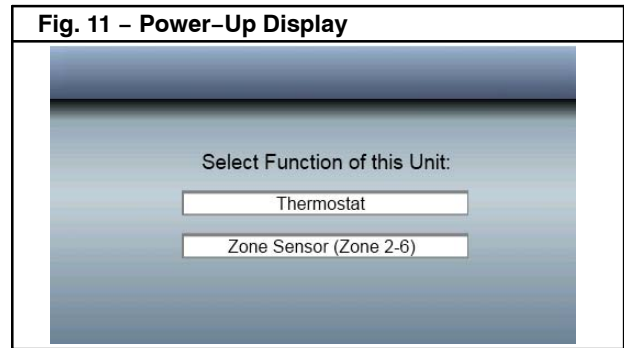

Select the proper option for the Observer Wall Control. The main control should be selected as Thermostat. If the Observer wall control is to be used as a zone sensor, select the second option, Zone Sensor.

If the Observer Wall Control is already installed in an application, the zoning panel, sensors, and dampers may be added at a later date. The Observer Wall Control must have software version 3.0 installed for it to communicate with the zoning panel and sensors.

NOTE: If the number of zones selected is less than 6, the remaining zones will be disabled.

After selecting Thermostat on the Observer Wall Control, it will search for communicating indoor equipment. If a communicating unit is found, it will proceed to search for a communicating outdoor unit, then the zoning panel and remote sensors.

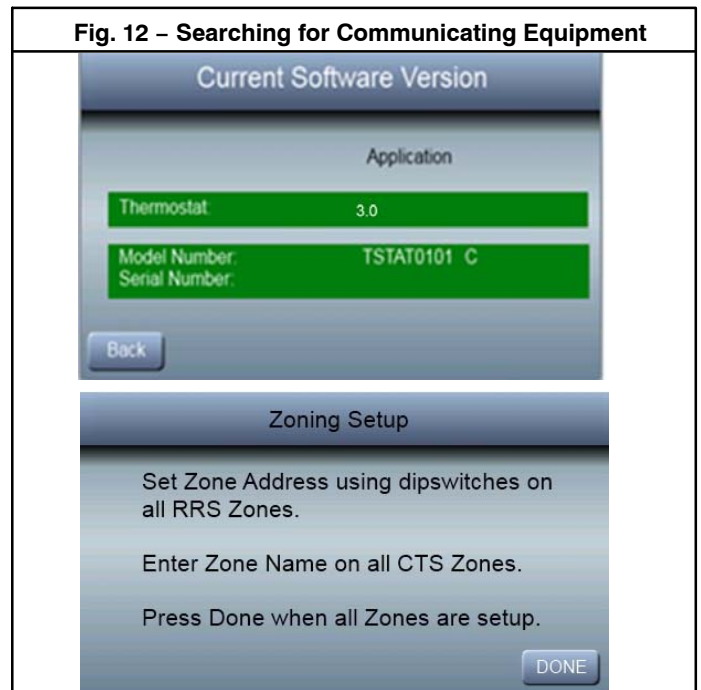

DAMPER

The Damper screen allows the selection of either 2 wire (spring open/spring closed) or 3 wire (power open/power closed) type. If a power open/spring closed-type damper is to be used, connect the damper wires to the Open and Common terminals on the Observer Zoning Board. If a power closed/spring open-type damper is to be used, connect the damper wires to the Close and Common terminals on the Observer Zoning Board.

Fig. 13 – System Wiring

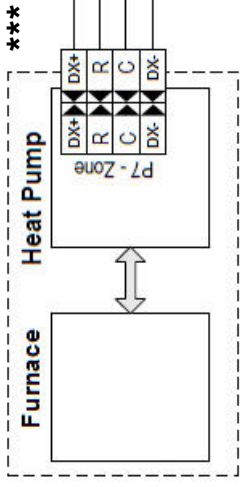
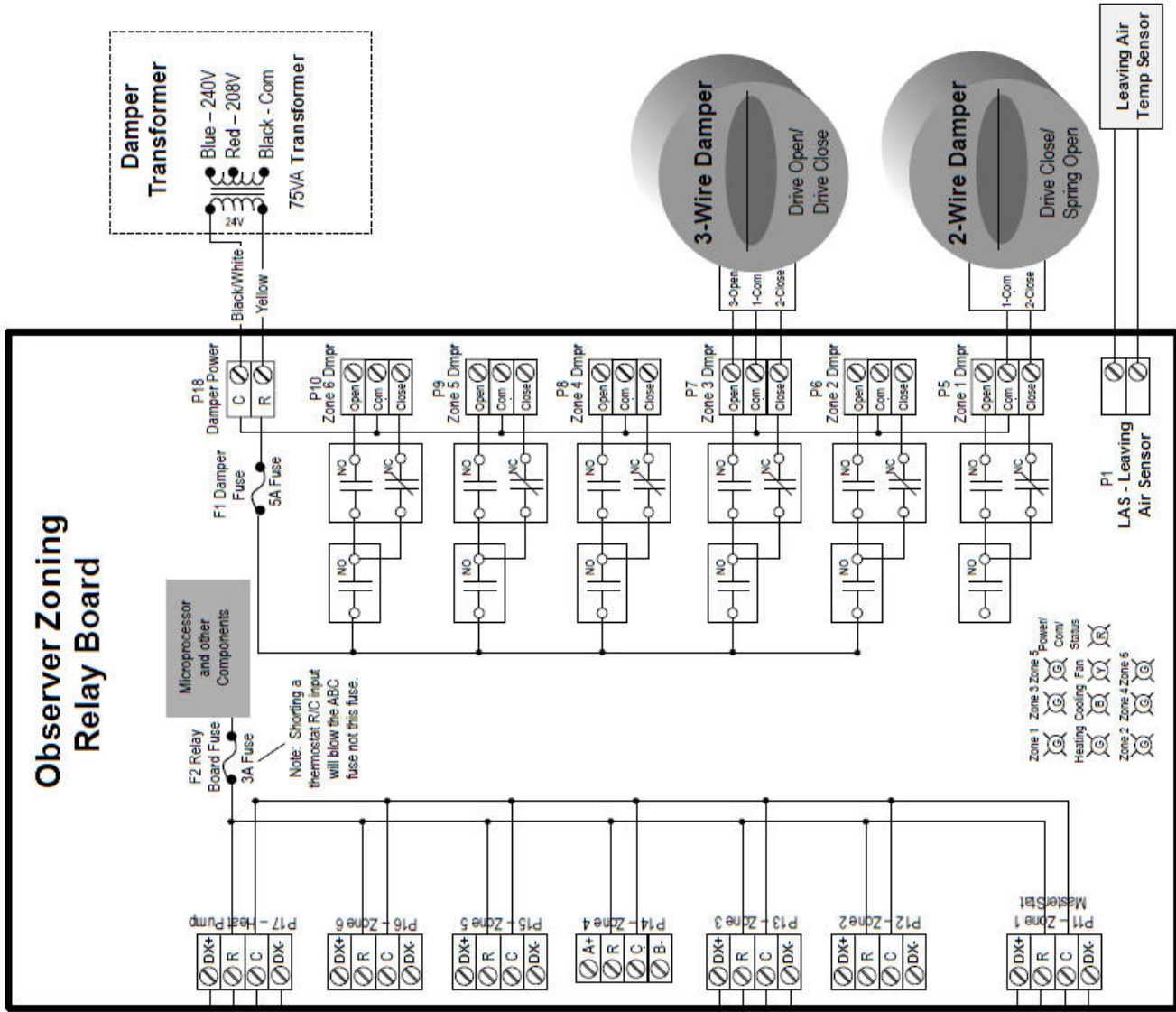

*** Designed for use with communicating equipment. Zoning can be used with Non-Communicating equipment by using a NAXA00101DB. PLEASE REFER to TSTAT0101SC set up instructions for more detailed information regarding proper daughterboard set up use.

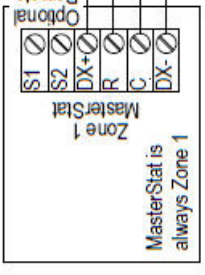
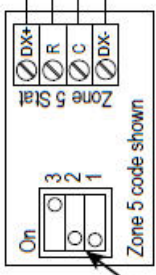

SensorStat

MasterStat

