

## R8182D,H Combination Protectorelay™ Primary Control and Aquastat® Controller

### INSTALLATION INSTRUCTIONS

#### APPLICATION

The R8182D,H Controllers combine a Protectorelay™ Primary Control and an Aquastat® Controller for use in oil-fired, hydronic heating systems. The Aquastat Controller provides high and low limit protection, circulator control, and minimum water temperature control for tankless domestic hot water service.

The Protectorelay Primary Control provides control of a line voltage, intermittent ignition oil burner when used with a C554A Cadmium Sulfide Flame Detector and a 24V thermostat.

The auxiliary ZC and ZR terminals provide zone control through an R845A Switching Relay. Each additional zone requires a separate 24V thermostat and an R845A Relay.

The R8182D,H also provide zone control using zone valves. Each additional zone requires a separate 24V thermostat and a V8043 or V8044 Zone Valve. The R8182D,H can be converted to provide only the high-limit to replace an R8182B,E or only the limit and circulator function to replace of the R8182C,F.

The R8182D mounts directly on the boiler. The R8182H mounts on a 4 by 4 in. junction box and has a 5 ft. (1.5m) capillary that allows a remote sensor location.

The R8182D includes

- Bag of heat-conductive compound for better heat transfer.
- High- and low-limit setting stops.
- One wire nut.

To order an immersion well or a well adapter, see form 68-0440, Wells and Fittings for Temperature Controllers, for part numbers and descriptions.

#### INSTALLATION

##### **WARNING**

**Explosion Hazard.**

**Can cause severe injury, death or property damage.**

Use this product only in systems with a pressure relief valve.

#### When Installing this Product...

1. Read these instructions carefully. Failure to follow them could damage product or cause a hazardous condition.
2. Check the ratings given in these instructions and on the product to be sure product is suitable for your application.
3. Be sure the installer is a trained, experienced service technician.
4. After completing installation, use these instructions to check product operation.

##### **WARNING**

**Electrical Shock Hazard and Explosion Hazard.**

**Can cause severe injury, death or equipment damage.**

1. Disconnect the power supply before beginning installation to prevent electrical shock or equipment damage.
2. Be sure that combustion chamber is clear of oil or oil vapor before starting burner.
3. Be sure that the ambient temperature at the element does not exceed 250°F (121°C).

##### **IMPORTANT**

*Be sure that the sensing bulb fits snugly inside the immersion well and that the sensing bulb rests against the bottom of the immersion well. If the sensing bulb does not fit snugly inside the immersion well, use the heat-conductive compound as described below. See Fig. 3.*

#### Mounting the R8182D

See Fig. 1 for R8182D installation dimensions and Fig. 4 for an internal view of the R8182D.

If existing immersion well does not fit the R8182D immersion well clamp, use a 124904 Immersion Well Adapter, ordered separately from form 68-0040.

1. Disconnect power supply.
2. Drain all water from boiler.
3. Fasten R8182D immersion well clamp to flange on immersion well adapter. See Fig. 3.
4. Place adapter on capillary tube.
5. Put adapter end into hole in controller case and tighten clamp screw.



- Insert sensing bulb into the immersion well and, if necessary, bend capillary tubing to hold sensing bulb against bottom of immersion well.

**NOTE:** Do not make sharp bends in capillary tubing. In models with an adjustable tubing length, pull the extra tubing out of the controller case.

- If necessary, apply heat-conductive compound into the immersion well.
  - Fold plastic bag of heat-conductive compound lengthwise and twist it gently.
  - Cut off end of plastic bag and work open end of bag all the way into immersion well.
  - Slowly pull bag out of immersion well while squeezing it firmly to distribute compound.
- Wipe off any excess heat-conductive compound and tighten set screw against adapter.

If the existing immersion well is not usable, remove the existing immersion well and order a new one using form 68-0040.

- Disconnect power supply.
- Drain all water from boiler.
- Install the new immersion well by threading it into the threaded hole.
- Loosen the immersion well clamp screw. See Fig. 3.
- Insert sensing bulb into the immersion well and, if necessary, bend capillary tubing to hold sensing bulb against bottom of immersion well.

**NOTE:** Do not make sharp turns while bending the capillary tubing. In models with an adjustable tubing length, pull the extra tubing out of the controller case.

- If necessary, apply heat-conductive compound into immersion well.
  - Fold plastic bag of heat-conductive compound lengthwise and twist it gently.
  - Cut off end of plastic bag and work open end of bag all the way into immersion well.
  - Slowly pull bag out of immersion well while squeezing firmly to distribute compound.
- Be sure immersion well fits hole in controller case.
- Position immersion well clamp snugly over immersion well flange. Tighten clamp screw securely.
- Refill boiler and check for water leakage.

## Mounting the R8182H

See Fig. 2 for R8182H installation dimensions and Fig. 5 for an internal view of R8182H.

- Disconnect power supply.
- Drain all water from boiler.
- Most boilers are equipped with a tapping that allows horizontal mounting of immersion well where average temperature boiler water circulates freely. If no tapping is provided, prepare one.
- Install immersion well or compression fitting (ordered separately) by threading into tapped hole.
- Loosen screw holding hinged backplate to controller case and swing backplate away from case.
- Screw backplate to 4 by 4 inch junction box.

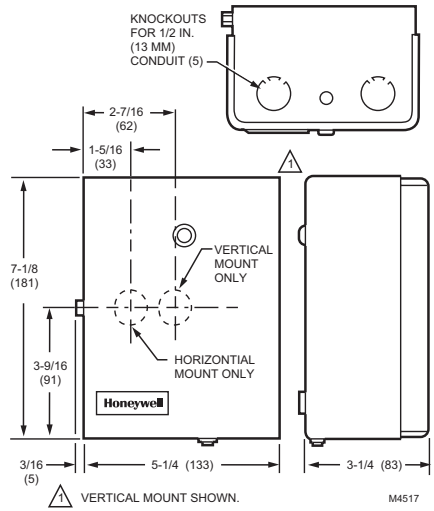

**Fig. 1. R8182D installation dimensions in in. (mm).**

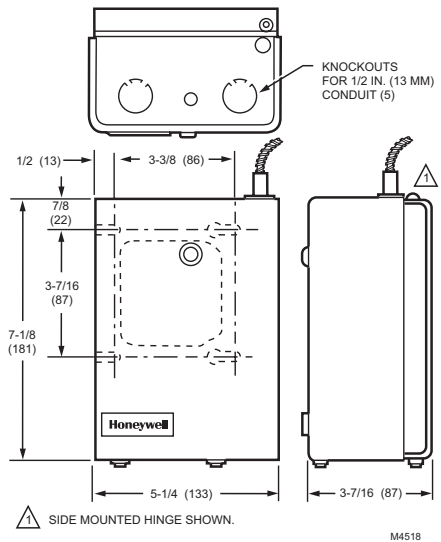

**Fig. 2. R8182H installation dimensions in in. (mm).**

- Insert sensing bulb into immersion well and, if necessary, bend capillary tubing to hold sensing bulb against bottom of immersion well.

**NOTE:** Do not make sharp turns while bending the capillary tubing. In models with an adjustable tubing length, pull the extra tubing out of the controller case.

8. If necessary, apply heat-conductive compound into the immersion well.
  - a. Fold plastic bag of heat-conductive compound lengthwise and twist it gently.
  - b. Cut off end of plastic bag and work open end of bag all the way into the immersion well.
  - c. Slowly pull bag out of the immersion well while squeezing it firmly to distribute compound.
9. Tighten the immersion well screw over brass collar.
10. After wiring, swing control case against backplate and refasten it with screw.
11. Refill the boiler and check for water leakage.

## WIRING

### IMPORTANT

- Use Underwriters Laboratories Inc. listed connectors when making external circuit connections to the orange and white line voltage burner and ignition leadwires of the R8182H.
- Terminals on the R8182 are approved for copper wire only.

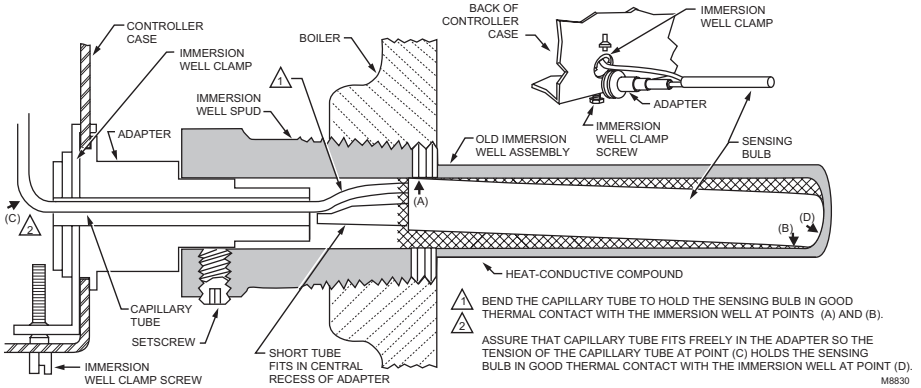

Fig. 3. Positioning the sensing bulb in the immersion well.

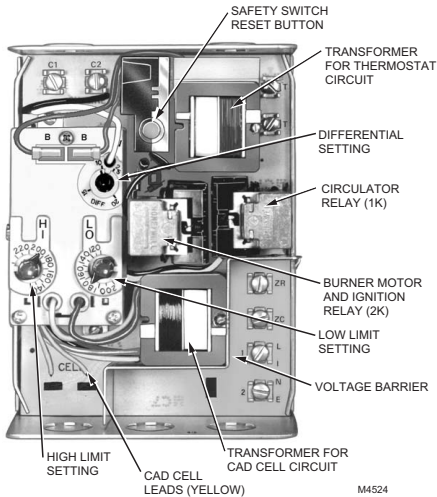

Fig. 4. Internal view of R8182D.

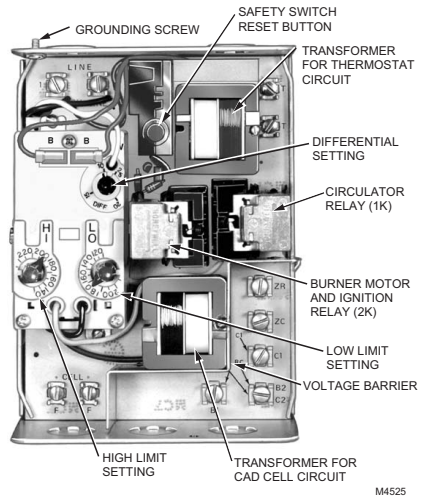

Fig. 5. Internal view of R8182H.

# ⚠ WARNING

**Electrical Shock Hazard.**  
**Can cause severe injury, death or equipment damage.**  
 Disconnect power supply before wiring to prevent electrical shock or equipment damage.

All wiring must comply with local codes, regulations, and ordinances.

Follow the wiring instructions furnished by the appliance manufacturer, if available, or see Fig. 6 through 9. For wiring multiple zoning systems, see Fig. 8 and 9.

The R8182 is equipped with special wiring terminals. Wires can be wrapped around the terminal screw or inserted from side.

## Method 1

- Strip 7/16 in. of insulation from wire end.
- Wrap wire 3/4 of distance around screw as shown.
- Using a standard, flat-head screwdriver, tighten screw until wire is snugly contacting screw and contact plate.
- Tighten screw an additional half turn.

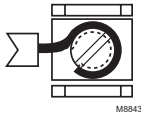

## Method 2

- Strip 5/16 in. of insulation from wire end.
- Insert wire beneath screw as shown.
- Follow steps 3 and 4 in Method 1.

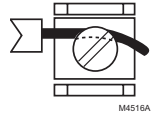

**NOTE:** Do not use a push-type ratchet screwdriver.

The TRADELINE® R8182D,H can be converted to replace an R8182B,C,E,F or a White Rodgers 6C92-2 or 6C92-3. When replacing a White Rodgers model, the immersion well must also be replaced. See Fig.5 for Aquastat limit connections necessary for each R8182D,H conversion.

To release the wires from the R8182, insert a screwdriver into the rectangular hole adjacent to the wire, push inward to release the locking-grip on the wire, and pull the wire out of the terminal hole.

To reinsert the wire into a new terminal hole, simply push the wire into the new slot.

USING THE TRADELINE® R8182D TO REPLACE R8182F:

- REMOVE BLUE WIRE FROM THIS TERMINAL AND INSULATE END TO PREVENT CONTACT.
- REMOVE OTHER BLUE WIRE FROM THIS TERMINAL AND CONNECT AS SHOWN BELOW.
- CONNECT CIRCULATOR TO ZC AND C2.

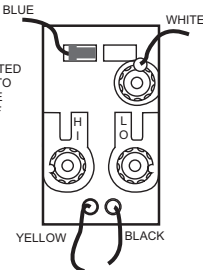

COMPLETED WIRING TO REPLACE R8182C,F

USING THE TRADELINE® R8182D TO REPLACE R8182B,E OR WHITE RODGERS 6C92:

- REMOVE WHITE AND BLACK LEADS FROM THEIR TERMINAL AND CONNECT WITH A SOLDERLESS CONNECTOR.
- TO USE TRADELINE® R8182H TO REPLACE R8182J:
- REMOVE RED AND WHITE LEADS FROM THEIR TERMINALS AND CONNECT WITH A SOLDERLESS CONNECTOR.

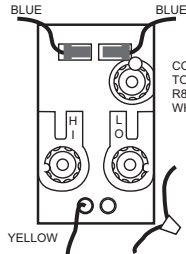
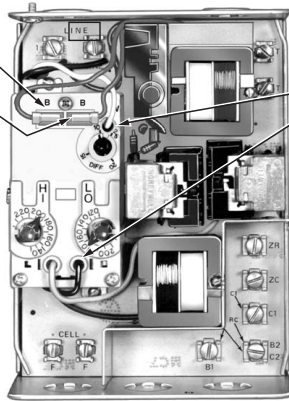

COMPLETED WIRING TO REPLACE R8182B,E AND WHITE RODGERS 6C92

**Fig. 6. Converting R8182D,H to replace other controls.**

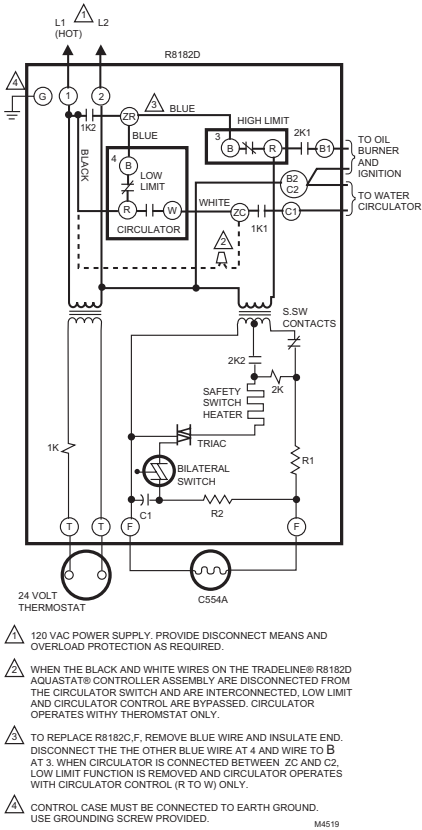

Fig. 7. Internal schematic and wiring diagram for R8182D.

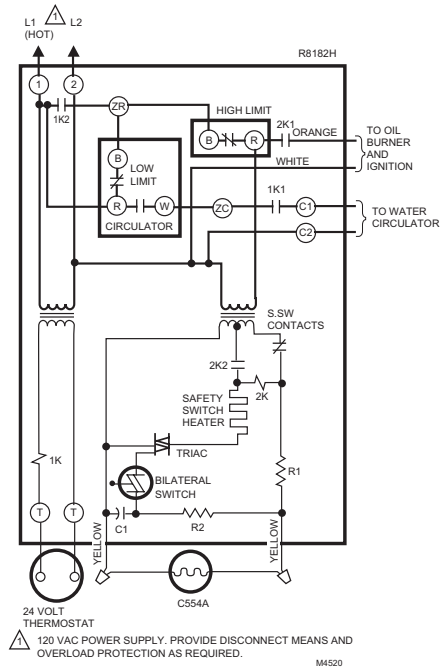

Fig. 8. R8182H internal schematic and wiring diagram.

## OPERATION

### R8182D wired for R8182B,E Replacement or R8182H wired for R8182J Replacement

When the R8182D or H is wired to exclude the low limit circulator switches, the burner and circulator operate whenever the thermostat calls for heat. On a call for heat from the thermostat, 1K relay pulls in to start the circulator. Then 1K2 closes and the 2K relay is energized, which causes the burner to ignite by closing the 2K1 contact. If the burner ignites and the cad cell sees flame, the safety switch heater is bypassed. When the thermostat is satisfied, the burner and circulator are shut off.

With this hookup, the circulator operates *whenever* the thermostat calls for heat (even if high limit is open).

### R8182D wired for R8182C,F Replacement

When the R8182D is wired to exclude the low limit function, the circulator is connected between the ZC and C2 terminals. The burner operates on a call for heat and the circulator operates *whenever* R-W is made.

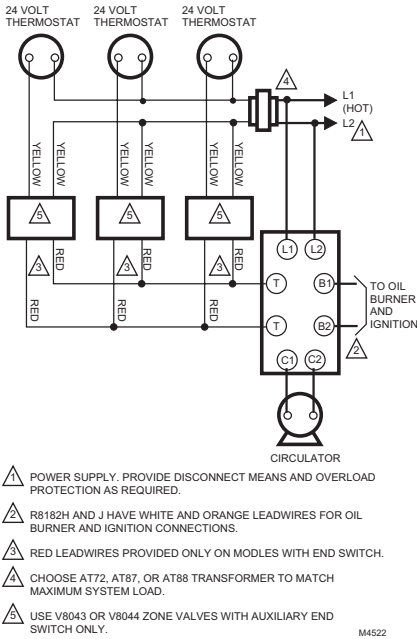

**Fig. 9. R8182D and R845A in typical multiple circulator zoning application.**

### R8182D,H (triple-function)

A call for heat by the thermostat pulls in 1K and 2K relays to turn on the burner, and the safety switch starts to heat. If the burner ignites within 45 seconds, the cad cell sees the flame and the safety switch heater is bypassed. The burner operates until the call for heat is satisfied. The circulator operates when relay 1K pulls in only if R to W in the Aquastat™ controller is made.

When R to B (low limit) is made by a drop in water temperature, it acts as a call for heat, pulling in relay 2K to turn on the burner. Circulator cannot operate.

### Multizone Control

In all multizone applications, a call for heat in any zone energizes the safety switch circuit and relay 2K pulls in. If burner ignites within the safety switch timing, the cad cell sees the flame and the safety switch heater is bypassed.

In all multizone applications, the low-limit control in the Aquastat™ controller acts independently to turn on the main burner on a drop in water temperature. When R to B (low-limit) is made, relay 2K pulls in to turn on the main burner, the same as for single zone applications.

### Zone Circulator Control with R8182D,H

The relay for each zone is connected to the Aquastat Controller through terminals ZC and ZR. The R845 relay and thermostat for each zone can energize the zone circulator through ZC *only* if R to W in the Aquastat controller is made. If R to B (high-limit) is made, the zone thermostat energizes the burner through ZR.

### Zone Valve Control with R8182D,H

The valve for each zone is connected to the Aquastat controller by wiring end switches on the zone valve to T-T on the R8182D,H. On a call for heat from any zone, the R8182D,H operates the same as in a single zone application.

## STARTUP AND CHECKOUT

### ▲ WARNING

**Explosion Hazard.**  
**Can cause severe injury, death or equipment damage.**

Use this product only in systems with a pressure relief valve.

Because heating systems differ, the correct temperature setting for one system may not be correct for another. Follow the boiler manufacture recommendations for proper selection of settings. See Fig. 11

### High-Limit Setting

The high-limit opens and turns off the burner when the water temperature reaches the setpoint. The high-limit automatically resets after the water temperature drops past the setpoint and through the 10°F (6°C) differential.

Set the indicator at the desired shutoff temperature.

### Low-Limit /Circulator Setting

On a temperature rise, with the adjustable differential at the minimum setting of 10°F (6°C), the burner circuit (R-B) breaks and the circulator circuit (R-W) makes at the low-limit setpoint. See Fig. 11. On a temperature drop of 10°F (6°C) below the setpoint, the R-B circuit makes and the R-W circuit breaks.

At any differential setting greater than 10°F (6°C), the R-B make temperature and R-W break temperature remains the same—control setting minus 10°F (6°C). The R-B break and R-W make temperature are the setpoint temperature plus the difference between the differential setting and 10°F (6°C).

**EXAMPLE:** Setpoint of 140°F (60°C), differential set at 25°F (14°C). On a temperature rise, R-B breaks and R-W makes at 155°F (70°C). On a temperature fall, R-B makes and R-W breaks at 130°F (54°C).

Set low-limit indicator at the minimum temperature recommended for domestic hot water supply. This setting *must* be at least 20°F (11°C) below high-limit setting to prevent one switch from locking out the other.

Set differential the desired number of degrees.

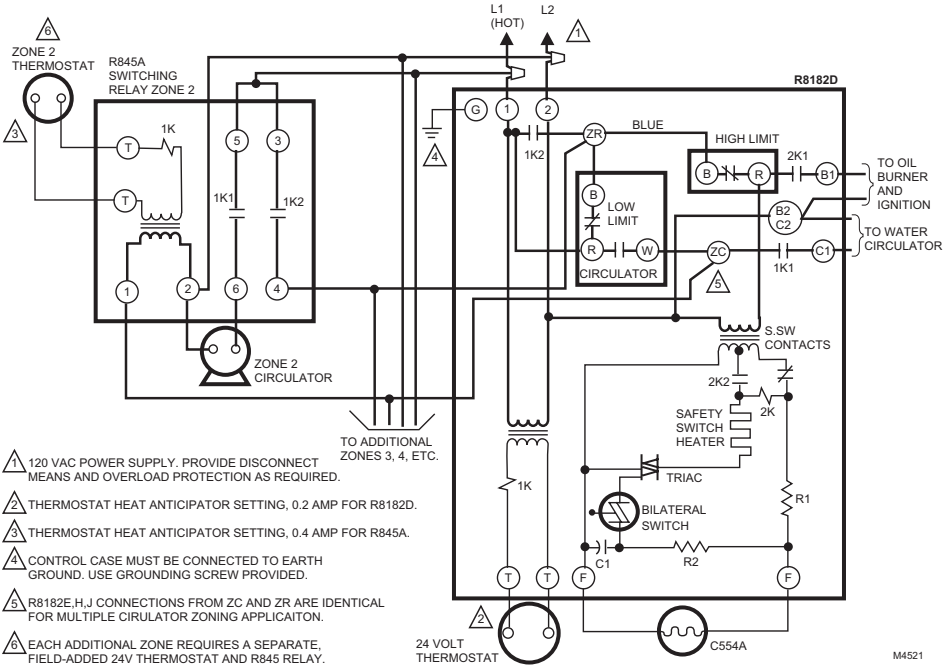

Fig. 10. R8182D,H in typical zone system using zone valves.

## Setting Stops

### IMPORTANT

Once the setting stops are in place, they cannot be replaced. If they must be removed, cut them off with cutters—do not twist off.

Part no. 126580 Setting Stops can be installed on the low- and high-limit adjusting knobs to prevent turning the knobs beyond a predetermined point. To install the setting stops, proceed as follows:

1. On low-limit knob, turn knob to setting that is to be established as the limit.
  2. Place setting stop over knob so that arm of setting stop (after stop is pressed into place) strikes projection A and prevents turning of knob beyond chosen limit setting (Fig. 11).
  3. Press setting stop tightly onto knob so its inner teeth securely engage knob.
  4. Turn knob back and forth several times to make sure stop functions properly.
  5. Repeat steps 1 through 4 for high-limit knob.
- After settings are made, replace the cover.

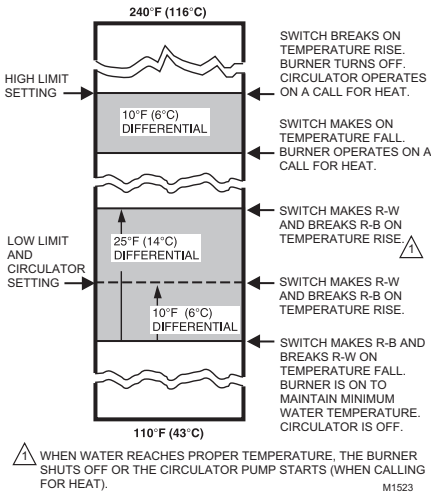

Fig. 11. R8182D,H Aquastat limit switching.

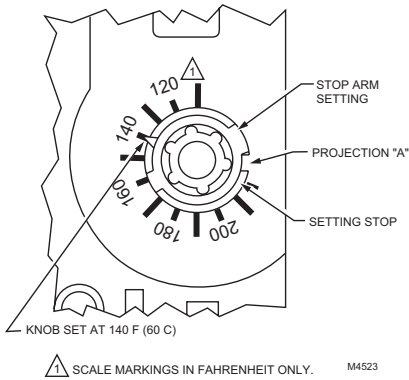

Fig. 12. Setting stop in position to restrict low limit setting to 180°F (82°C) or lower.

Make certain the system operates as described in the OPERATION section. Use the following procedure to verify that the Protectorelay® control is controlling properly.

### Flame Failure Check

Shut off the oil supply hand valve while the burner is on. After 45 seconds, the safety switch locks out, the motor stops, and the oil valve closes. Allow five minutes for the burner to cool, then manually reset the safety switch.

### Ignition Failure Check

Test by closing the oil supply while the burner is off. Run through the starting procedure, but do not open the oil supply line hand valve. The safety switch locks out as in flame failure. Then turn the oil back on, and reset the safety switch.

### Power Failure Check

Turn off the power supply while the burner is on. When the burner goes out, restore power and the burner will restart.

NOTE: If operation is not as described, see cover insert for additional information and check the wiring.

### Aquastat Replacement

The Aquastat controller section of the Protectorelay control is field replaceable. When ordering a replacement assembly, specify the complete model number of the R8182.

To replace the Aquastat Controller:

1. Disconnect power supply.
2. *Note position of connecting wires.*
3. Remove fastening screws and wires.
4. Remove Aquastat controller and install new assembly.

## Startup

### **⚠** WARNING

**Explosion Hazard.**  
**Can cause severe injury, death or property damage.**  
 Be sure combustion chamber is free of oil or vapor.

1. Push red reset button and release.
2. Open hand valve on oil supply line.
3. Set thermostat to call for heat.
4. Close line switch; burner will start.
5. Under normal conditions, burner operates until thermostat is satisfied or line switch is opened.

## MATERIAL SAFETY DATA SHEET (MSDS)

### SECTION 1. PRODUCT AND COMPANY IDENTIFICATION.

Product Name: Heat conductive compound.

MSDS ID: DS9021.

Synonyms: MS1699.

Product Use: Heat conductive material used to enhance contact and heat transfer in temperature sensor applications.

Manufacturer: Honeywell Inc., 1985 Douglas Drive North, Minneapolis, MN 55422.

Date Released: October 8, 1999.

Emergency Telephone Information: 1-888-809-3787.

NFPA Ratings:

Health 0; Flammability 1; Reactivity 0; Personal Protection B.



## Section 2. Composition, Information on Ingredients (Table 1).

Table 1. Ingredients of Heat Conductive Compound<sup>a</sup>.

Ingredients	CAS Number	Percent	PEL	TLV
No. 2 Lithium Complex Grease (70%):				
Mineral Oil	64742-65-0	35-50	5 mg/m <sup>3</sup>	5 mg/m <sup>3</sup>
Mineral Oil	64742-62-7	20-25	5 mg/m <sup>3</sup>	5 mg/m <sup>3</sup>
Lithium Hydrostearate/Sebacate Complex	68815-49-6	4-9	—	—
Zinc Alkyldithiophosphate	68649-42-3	0-2	—	—
Aluminum Paste (30%):				
Aluminum, as Al	7429-90-5	20-25	15 mg/m <sup>3</sup>	10 mg/m <sup>3</sup>
Aliphatic Petroleum Distillates	8052-41-3	10-15	2900 mg/m <sup>3</sup>	525 mg/m <sup>3</sup>
Stearic Acid	57-11-4	1-2	—	—
Aromatic Petroleum Distillates	64742-95-6	1-2	5 mg/m <sup>3</sup>	5 mg/m <sup>3</sup>

<sup>a</sup> Additional Information: Part No. 120650 (0.5 oz. tube); Part No. 107408 (4 oz. can); Part number 197007 (5 gallon container). May also contain minute amounts of lithium and molybdenum lubricant compounds.

## Section 3. Hazard Identification

### Acute Health Effects:

Skin—Excessive contact can cause skin irritation and dermatitis.

Eye—Direct contact with eye will cause irritation.

Inhalation—No adverse effects are expected.

Ingestion—Ingestion of product may cause nausea, vomiting and diarrhea.

### Chronic Health Effects:

Existing skin rash or dermatitis may be aggravated by repeated contact.

### OSHA Hazard Classifications:

None.

### Carcinogenicity:

Not considered to be a carcinogen by either OSHA, NTP, IARC, or ACGIH.

### Target Organs:

None known.

## Section 4. First Aid Measures

### Eye Contact:

Flush eyes with water for 15 minutes. Remove any contact lenses and continue to flush. Obtain medical attention if irritation develops and persists.

### Skin Contact:

Remove excess with cloth or paper. Wash thoroughly with mild soap and water. Obtain medical attention if irritation develops and persists.

### Ingestion:

Contact physician or local poison control center immediately.

### Inhalation:

Remove patient to fresh air and obtain medical attention if symptoms develop.

## Section 5. Fire Fighting Measures

### Flash Point:

>383°F (195°C). Will burn if exposed to flame.

### Extinguishing Media:

Carbon dioxide, dry chemical or foam.

### Special Fire Fighting Procedures:

None.

### Explosion Hazards:

None. Aluminum powder can react with water to release flammable hydrogen gas. In the form of this product, this reaction is not expected.

## Section 6. Accidental Release Measures

Scrape up and dispose as solid waste in accordance with state and federal regulations.

## Section 7. Handling and Storage

Store in dry place. Keep container closed when not in use.

## Section 8. Exposure Controls and Personal Protection

### Ventilation:

No special ventilation is required when working with this product.

### Respiratory Protection:

None required.

### Eye Protection:

Not normally required. However, use chemical safety goggles or faceshield if potential for eye contact exists, especially if material is heated.

### Hand/Clothing Protection:

Not normally required. Protective gloves and clothing are recommended, as material is difficult to remove from skin and clothing.

### Other Protective Equipment:

None required.

## Section 9. Physical and Chemical Properties

### Appearance/Odor:

Aluminum color, semi-solid material, pleasant odor.

### Solubility in Water:

Negligible.

### Specific Gravity:

0.86.

## Section 10. Stability and Reactivity

### Stability:

Stable.

### Reactivity:

Hazardous polymerization will not occur.

### Incompatibilities:

Strong oxidizing agents and halogens.

### Hazardous Decomposition Products:

Carbon dioxide, carbon monoxide.

## Section 11. Toxicology Information

No data available.

## Section 12. Ecological Information

### Chemical Fate Information:

Hydrocarbon components will biodegrade in soil; relatively persistent in water.

## Section 13. Disposal Consideration

Dispose of as solid waste in accordance with Local, State and Federal regulations.

## Section 14. Transportation Information

### DOT Classification:

Not classified as hazardous.

## Section 15. Regulatory Information

### SARA Title III Supplier Notification:

Include in Section 311/312 inventory reports if amounts exceed 10,000 pounds. Aluminum compounds are subject to the reporting requirements under Section 313 of Emergency Planning and Community Right-to-Know Act of 1986 (40 CFR 372). Ingredients listed in TSCA Inventory.

## Section 16. Other Information

This information is furnished without warranty, expressed or implied, except that it is accurate to the best of our knowledge.

### Prepared By:

PROSAR, 1295 Bandana Boulevard, Suite 335, St. Paul, MN 55108 (651-917-6100).

**Honeywell**

---

**Automation and Control Solutions**

Honeywell  
1985 Douglas Drive North  
Golden Valley, MN 55422

Honeywell Limited-Honeywell Limitée  
35 Dynamic Drive  
Scarborough, Ontario  
M1V 4Z9

