

INSTALLATION INSTRUCTIONS

(FVIR) System Thermocouple Assembly Replacement Kit

Read these instructions thoroughly and understand all steps and procedures before proceeding with the installation.

▲ CAUTION: The burner chamber is a sealed area. If the burner access door is removed, the burner access door gasket must be replaced. This should only be done by a qualified service technician.

1. INSPECT SHIPMENT:

Inspect contents for possible missing or damaged components. See Figure 1. This kit includes:

- 1 - Burner Access Door Gasket
- 4 - Speed Clips
- 4 - T20 Torx Head Screws
- 1 - Thermocouple

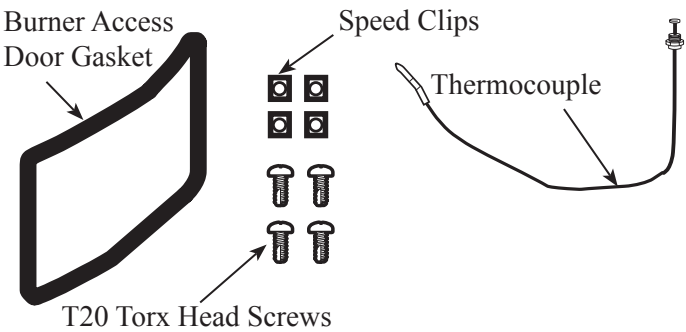

Figure 1

2. ADDITIONAL INSTRUCTIONS REQUIRED:

Refer to the Use and Care Manual supplied with the water heater for complete information on the installation, lighting instructions, operation and maintenance of the water heater.

3. SHUT OFF THE GAS SUPPLY:

Turn the temperature dial "counter clockwise" ⤴ to the lowest setting. Shut off the gas supply to the water heater by turning the gas cock knob "clockwise" ⤵ to the "OFF" position. Turn off the gas supply at the main gas line. Refer to the label located above the gas valve for additional information on shutting off the gas supply.

5. REMOVE THE JACKET DOOR:

Remove the jacket door by grasping the round center of the door and pushing inward and to the left or right to release one side then release the opposite side and remove the jacket door from the water heater.

6. REMOVAL OF CONNECTIONS TO GAS VALVE:

Unscrew the pilot supply tube, the thermocouple, the burner supply tube, and unplug the ignitor wire from the bottom of the piezo ignitor striker. See Figure 2.

7. REMOVAL OF T20 TORX HEAD SCREWS:

Remove the four T20 Torx head screws at the corners of the Burner Access Door and discard.

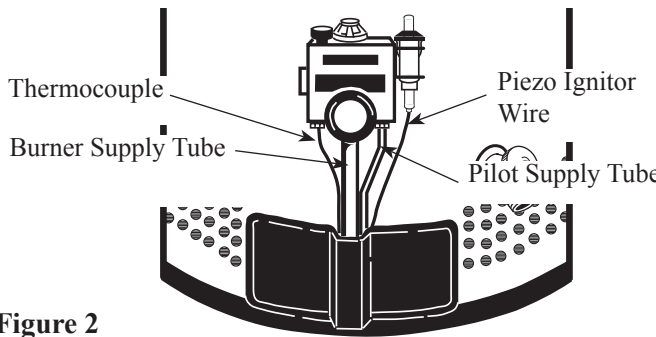

Figure 2

You will need a #20 size TORX head tool.

8. REMOVAL OF BURNER ACCESS DOOR:

Remove the Burner Access Door Assembly. If removal is difficult you can insert a flat head screw driver between the door and the burner chamber and pry the two apart all around the outside area of the burner access door.

Grasp the Burner Supply Tube and remove the burner access door assembly from the burner chamber.

9. REMOVING THE THERMOCOUPLE:

Remove the thermocouple from the burner assembly by cutting the wire with wire cutters and pulling it through the orange grommet from the front side of the door.

Remove the remainder of the thermocouple from the bracket by pulling firmly on the thermocouple. Then pull the old thermocouple and remaining wire through from the back of the burner access door assembly.

10. REPLACING THE THERMOCOUPLE:

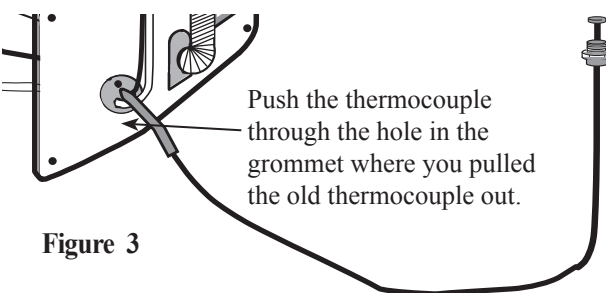

Figure 3

Install the new thermocouple by pushing the metal tip of the thermocouple thru the orange grommet as shown in Figure 3. Take care not to damage the grommet or push it out as you push the thermocouple through it.

Push the thermocouple into the thermocouple bracket until it seats all the way into the bracket.

Do not bend the thermocouple within 1" of tip when installing, as this may damage the thermocouple. See Figure 4.

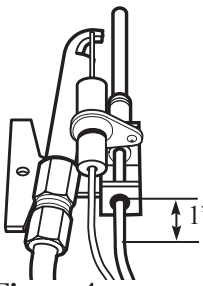

Figure 4

Make sure there are no sharp bends in the thermocouple and that there is at least a 1" section of straight thermocouple coming from the bracket.

Direct all connections to the burner assembly away from and below the flame of the burner.

11. PREPARE TO INSTALL THE BURNER ACCESS DOOR:

Remove the old door gasket and clean the metal surfaces on which the old gasket was attached on the back of the door and the front of the burner chamber area.

The outside edge may be scraped with a putty knife, sanded lightly with sand paper, and washed with a light soap and water mixture to remove the old gasket material and adhesive.

▲ WARNING: Do not use flammable liquids such as gasoline, paint thinners, or solvents to remove the old gasket material and adhesive.

NOTICE: A new gasket must replace the existing one prior to reassembly.

Install a new gasket on the back of the Burner Access Door by removing the pull away tabs on the gasket and sticking the new gasket to the back of the Burner Access Door, aligning the holes in the gasket with the holes on the Burner Access Door for the T20 Torx head screws.

12. INSTALL THE BURNER ACCESS DOOR:

Insert the burner access door assembly back into the burner chamber and reassemble in the reverse order of removal. Make sure the gasket is fully seated.

Make sure the speed clips are tight in place upon reinstallation of the door. Extra speed clips are provided in the event some are lost or damaged in the removal of the burner access door.

When connecting the pilot supply tube, make sure it is seated into the valve straight to help prevent cross-threading of the connection and an improper alignment with the gas valve. Use a wrench to snug the connection to the valve to prevent gas leakage. Make sure there are no sharp bends in the pilot supply tube and that there is at least a 1" section of straight pilot supply tube coming from the bracket.

When connecting the burner supply tube, make sure the connection is not cross threaded.

When connecting the thermocouple, make sure it is inserted into the valve straight to prevent damage to the thermocouple. The thermocouple should be no more than one quarter (1/4) turn beyond hand tight.

When connecting the piezo ignitor wire to the bottom of the piezo ignitor striker, make sure to pull all excess wire to the outside of the burner chamber to prevent unnecessary exposure to burner flame.

Tighten the T20 Torx head screws to no more than 15 inch pounds of torque using the TORX head tool, **DO NOT** over tighten. **DO NOT USE POWER TOOLS.**

▲ WARNING: Failure to properly install the burner access door could result in a potentially hazardous situation that could result in death or serious injury and/or property damage.

13. GAS SUPPLY:

Turn the gas supply on at the main gas line, turn the gas cock knob "counterclockwise" \cup to the pilot position and relight the pilot per the lighting instructions located on the heater and in the Use & Care Manual.

14. THERMOCOUPLE OPERATION

Check that the pilot is lit and the thermocouple is enveloped 3/8" to 1/2" by the pilot flame by looking through the sight glass located on the door.

Turn the gas cock knob to the "ON" position.

15. MAIN BURNER OPERATION:

Check the operation of the burner through the sight glass located on the burner access door.

16. CHECK FOR LEAKS:

Check the burner supply tube and pilot supply tube at the gas control valve for gas leaks with a soap and water solution.

The appearance of bubbles indicate a leak.

Tighten all connections if a leak is found and check once again with solution.

17. TEMPERATURE SETTING:

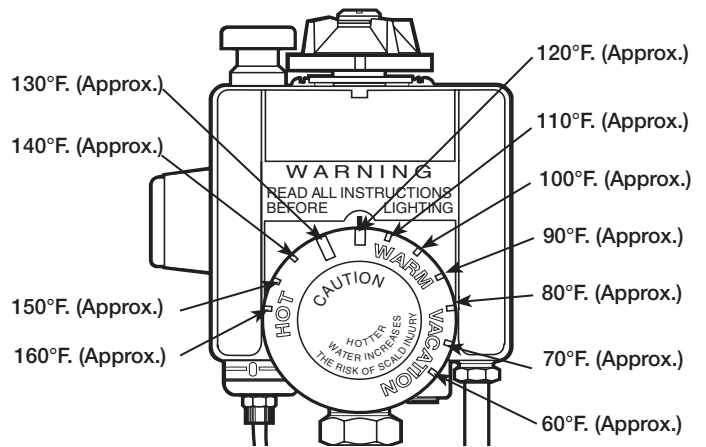

▲ DANGER: Hotter water increases the potential for Hot Water SCALDS.

Turn the temperature dial to the desired setting. The recommended starting point temperature is 120°F.

The illustration above details the approximate water temperature for each mark on the Gas Control (Thermostat) temperature Dial.

18. REPLACE JACKET DOOR:

Replace the jacket door by inserting one end of the door behind the jacket edge then insert the opposite end of the door behind the jacket edge and release the door.