



**WEATHERMAKER®**  
**48/50AJ,AK,AW,AY,A2,A3,A4,A5020-060**  
**Single Package Large Rooftop Units**  
**with COMFORTLINK Version 6.x Controls**

# Controls, Start-Up, Operation, Service and Troubleshooting

## CONTENTS

	Page		Page
<b>SAFETY CONSIDERATIONS</b> .....	2,3	<b>Unit Configuration Submenu</b> .....	35
<b>GENERAL</b> .....	3,4	<b>Cooling Control</b> .....	37
<b>Conventions Used in this Manual</b> .....	3	• SETTING UP THE SYSTEM	
<b>BASIC CONTROL USAGE</b> .....	4-7	• MACHINE DEPENDENT CONFIGURATIONS	
<b>ComfortLink Controls</b> .....	4	• SET POINTS	
<b>Scrolling Marquee</b> .....	4	• SUPPLY AIR RESET CONFIGURATION	
<b>Accessory Navigator™ Display</b> .....	4	• COOLING CONFIGURATION	
<b>Operation</b> .....	5	• COMPRESSOR SAFETIES	
<b>System Pilot™ Interface</b> .....	5	• COMPRESSOR TIME GUARDS	
<b>CCN Tables and Display</b> .....	5	• COOL MODE SELECTION PROCESS	
• GENERICS STATUS DISPLAY TABLE		• COOLING MODE DIAGNOSTIC HELP	
<b>START-UP</b> .....	7-27	• SUMZ COOLING ALGORITHM	
<b>Unit Preparation</b> .....	7	• DEMAND LIMIT CONTROL	
<b>Unit Setup</b> .....	7	• HEAD PRESSURE CONTROL	
<b>Internal Wiring</b> .....	7	• ECONOMIZER INTEGRATION WITH MECHANICAL COOLING	
<b>Accessory Installation</b> .....	7	<b>Heating Control</b> .....	50
<b>Crankcase Heaters</b> .....	7	• SETTING UP THE SYSTEM	
<b>Evaporator Fan</b> .....	7	• HEAT MODE SELECTION PROCESS	
<b>Controls</b> .....	7	• TEMPERATURE DRIVEN HEAT MODE EVALUATION	
<b>Gas Heat</b> .....	7	• HEAT MODE DIAGNOSTIC HELP	
<b>CONTROLS QUICK START</b> .....	27-29	• INTEGRATED GAS CONTROL BOARD LOGIC	
<b>Two-Stage Constant Volume Units with Mechanical Thermostat</b> .....	27	• RELOCATE SAT SENSOR FOR HEATING IN LINKAGE SYSTEMS	
<b>Two-Stage Constant Volume Units with Space Sensor</b> .....	27	• MORNING WARM UP	
<b>Variable Air Volume Units Using Return Air Sensor or Space Temperature Sensor</b> .....	28	• TEMPERING MODE	
<b>Multi-Stage Constant Volume Units with Mechanical Thermostat</b> .....	28	<b>Static Pressure Control</b> .....	57
<b>Multi-Stage Constant Volume Units with Space Sensor</b> .....	28	• OPERATION	
<b>Economizer Options</b> .....	28	• SETTING UP THE SYSTEM	
<b>Indoor Air Quality Options</b> .....	29	• STATIC PRESSURE RESET OPERATION	
<b>Exhaust Options</b> .....	29	• RELATED POINTS	
<b>Programming Operating Schedules</b> .....	29	<b>Fan Status Monitoring</b> .....	60
<b>SERVICE TEST</b> .....	29,30	• GENERAL	
<b>General</b> .....	29	• SETTING UP THE SYSTEM	
<b>Service Test Mode Logic</b> .....	29	• SUPPLY FAN STATUS MONITORING LOGIC	
<b>Independent Outputs</b> .....	30	<b>Dirty Filter Switch</b> .....	60
<b>Fans in Service Test Mode</b> .....	30	<b>Economizer</b> .....	61
<b>Cooling in Service Test Mode</b> .....	30	• SETTING UP THE SYSTEM	
<b>Heating in Service Test Mode</b> .....	30	• ECONOMIZER OPERATION	
<b>THIRD PARTY CONTROL</b> .....	31,32	• UNOCCUPIED ECONOMIZER FREE COOLING	
<b>Thermostat</b> .....	31	• ECONOMIZER OPERATION CONFIGURATION	
<b>Alarm Output</b> .....	31	• ECONOMIZER DIAGNOSTIC HELP	
<b>Remote Switch</b> .....	31	<b>Building Pressure Control</b> .....	64
<b>VFD Control</b> .....	31	• BUILDING PRESSURE CONFIGURATION	
<b>Supply Air Reset</b> .....	31	• CONSTANT VOLUME 2-STAGE CONTROL OPERATION	
<b>Demand Limit Control</b> .....	31	• MULTIPLE POWER EXHAUST STAGE BUILDING PRESSURE CONTROL OPERATION	
<b>Demand Controlled Ventilation Control</b> .....	31	• VFD POWER EXHAUST BUILDING PRESSURE CONTROL	
<b>CONTROLS OPERATION</b> .....	32-76	<b>Smoke Control Modes</b> .....	67
<b>Modes</b> .....	32	• FIRE-SMOKE INPUTS	
• SYSTEM MODES		• AIRFLOW CONTROL DURING THE FIRE-SMOKE MODES	
• HVAC MODES		• RELEVANT ITEMS	

Manufacturer reserves the right to discontinue, or change at any time, specifications or designs without notice and without incurring obligations.

## CONTENTS (cont)

	Page
<b>Indoor Air Quality Control</b> .....	67
• OPERATION	
• SETTING UP THE SYSTEM	
• PRE-OCCUPANCY PURGE	
<b>Dehumidification and Reheat</b> .....	70
• SETTING UP THE SYSTEM	
• OPERATION	
<b>Temperature Compensated Start</b> .....	71
• SETTING UP THE SYSTEM	
• TEMPERATURE COMPENSATED START LOGIC	
<b>Carrier Comfort Network® (CCN) System</b> .....	72
<b>Alert Limit Configuration</b> .....	73
<b>Sensor Trim Configuration</b> .....	73
<b>Discrete Switch Logic Configuration</b> .....	74
<b>Display Configuration</b> .....	75
<b>Remote Control Switch Input</b> .....	75
<b>Hot Gas Bypass</b> .....	76
<b>Space Temperature Offset</b> .....	76
<b>TIME CLOCK CONFIGURATION</b> .....	76-78
<b>TROUBLESHOOTING</b> .....	78-102
<b>Complete Unit Stoppage</b> .....	78
<b>Single Circuit Stoppage</b> .....	78
<b>Service Analysis</b> .....	78
<b>Restart Procedure</b> .....	78
<b>Thermistor Troubleshooting</b> .....	78
<b>Transducer Troubleshooting</b> .....	79
<b>Forcing Inputs and Outputs</b> .....	91
<b>Run Status Menu</b> .....	91
• AUTO VIEW OF RUN STATUS	
• ECONOMIZER RUN STATUS	
• COOLING INFORMATION	
• MODE TRIP HELPER	
• CCN/LINKAGE DISPLAY TABLE	
• COMPRESSOR RUN HOURS DISPLAY TABLE	
• COMPRESSOR STARTS DISPLAY TABLE	
• TIME GUARD DISPLAY TABLE	
• SOFTWARE VERSION NUMBERS DISPLAY TABLE	
<b>Alarms and Alerts</b> .....	94
<b>MAJOR SYSTEM COMPONENTS</b> .....	102-128
<b>General</b> .....	102
<b>Factory-Installed Components</b> .....	102
<b>Accessory Control Components</b> .....	125
<b>SERVICE</b> .....	129-140
<b>Service Access</b> .....	129
<b>Cleaning</b> .....	129
<b>Lubrication</b> .....	131
<b>Evaporator Fan Performance Adjustment</b> .....	131
<b>Evaporator Fan Coupling Assembly</b> .....	131
<b>Evaporator Fan Service and Replacement</b> .....	132
<b>Belt Tension Adjustment</b> .....	132
<b>Evaporator-Fan Motor Replacement</b> .....	132
<b>Condenser-Fan Adjustment</b> .....	133
<b>Four-Inch Filter Replacement</b> .....	133
<b>Power Failure</b> .....	133
<b>Refrigerant Charge</b> .....	133
<b>Thermostatic Expansion Valve (TXV)</b> .....	133
<b>Gas Valve Adjustment</b> .....	133
<b>Main Burners</b> .....	140
<b>Filter Drier</b> .....	140
<b>Replacement Parts</b> .....	140
<b>APPENDIX A — LOCAL DISPLAY TABLES</b> .....	141-148
<b>APPENDIX B — CCN TABLES</b> .....	149-161
<b>APPENDIX C — VFD INFORMATION</b> .....	162-170
<b>APPENDIX D — MODE SELECTION PROCESS</b> .....	171
<b>APPENDIX E — UPC OPEN CONTROLLER</b> .....	172-183
<b>INDEX</b> .....	184
<b>CONTROLS SET POINT AND CONFIGURATION LOG</b> .....	CL-1 to CL-5
<b>UNIT START-UP CHECKLIST</b> .....	CL-6

## SAFETY CONSIDERATIONS

Installation and servicing of air-conditioning equipment can be hazardous due to system pressure and electrical components. Only trained and qualified service personnel should install, repair, or service air-conditioning equipment. Untrained personnel can perform the basic maintenance functions of replacing filters. Trained service personnel should perform all other operations.

When working on air-conditioning equipment, observe precautions in the literature, tags and labels attached to the unit, and other safety precautions that may apply. Follow all safety codes. Wear safety glasses and work gloves. Use quenching cloth for unbrazing operations. Have fire extinguishers available for all brazing operations.

### WARNING

Before performing service or maintenance operation on unit turn off and lock off main power switch to unit. Electrical shock can cause personal injury and death. Shut off all power to this equipment during installation and service. The unit may have an internal non-fused disconnect or a field-installed disconnect. **Note that the unit may also be equipped with a convenience outlet, that this outlet is wired to the line side of the unit-mounted disconnect and will remain hot when the disconnect in the unit is off. There is a separate fuse/disconnect for the convenience outlet.**

### CAUTION

Puron® refrigerant (R-410A) systems operate at higher pressures than standard R-22 systems. Do not use R-22 service equipment or components on Puron refrigerant equipment. If service equipment is not rated for Puron refrigerant, equipment damage or personal injury may result.

### CAUTION

This unit uses a microprocessor-based electronic control system. **Do not** use jumpers or other tools to short out components or to bypass or otherwise depart from recommended procedures. Any short-to-ground of the control board or accompanying wiring may destroy the electronic modules or electrical components.

### WARNING

1. Improper installation, adjustment, alteration, service, or maintenance can cause property damage, personal injury, or loss of life. Refer to the User's Information Manual provided with this unit for more details.
2. Do not store or use gasoline or other flammable vapors and liquids in the vicinity of this or any other appliance.

#### **What to do if you smell gas:**

1. DO NOT try to light any appliance.
2. DO NOT touch any electrical switch, or use any phone in your building.
3. IMMEDIATELY call your gas supplier from a neighbor's phone. Follow the gas supplier's instructions.
4. If you cannot reach your gas supplier call the fire department.

**⚠ WARNING**

DO NOT USE TORCH to remove any component. System contains oil and refrigerant under pressure.

To remove a component, wear protective gloves and goggles and proceed as follows:

- a. Shut off electrical power to unit.
- b. Recover refrigerant to relieve all pressure from system using both high-pressure and low pressure ports.
- c. Traces of vapor should be displaced with nitrogen and the work area should be well ventilated. Refrigerant in contact with an open flame produces toxic gases.
- d. Cut component connection tubing with tubing cutter and remove component from unit. Use a pan to catch any oil that may come out of the lines and as a gage for how much oil to add to the system.
- e. Carefully unsweat remaining tubing stubs when necessary. Oil can ignite when exposed to torch flame.

Failure to follow these procedures may result in personal injury or death.

**⚠ CAUTION**

DO NOT re-use compressor oil or any oil that has been exposed to the atmosphere. Dispose of oil per local codes and regulations. DO NOT leave refrigerant system open to air any longer than the actual time required to service the equipment. Seal circuits being serviced and charge with dry nitrogen to prevent oil contamination when timely repairs cannot be completed. Failure to follow these procedures may result in damage to equipment.

**GENERAL**

This book contains Start-Up, Controls Operation, Troubleshooting and Service information for the 48/50A Series rooftop units. See Table 1. These units are equipped with *ComfortLink* controls.

Use this guide in conjunction with the separate installation instructions packaged with the unit. Refer to the Wiring Diagrams literature for more detailed wiring information.

**Table 1 — A Series Product Line**

UNIT	APPLICATION
48AJ	CV Unit with Gas Heat, Vertical Supply
48AK	VAV Units with Gas Heat, Vertical Supply
48AW	CV Unit with Gas Heat, Horizontal Supply
48AY	VAV Unit with Gas Heat, Horizontal Supply
48A2	CV Unit with Gas Heat, Vertical Supply with MCHX Coil
48A3	VAV Unit with Gas Heat, Vertical Supply with MCHX Coil
48A4	CV Unit with Gas Heat, Horizontal Supply with MCHX Coil
48A5	VAV Unit with Gas Heat, Horizontal Supply with MCHX Coil
50AJ	CV Unit with Optional Electric Heat, Vertical Supply
50AK	VAV Unit with Optional Electric Heat, Vertical Supply
50AW	CV Unit with Optional Electric Heat, Horizontal Supply
50AY	VAV Unit with Optional Electric Heat, Horizontal Supply
50A2	CV Unit with Optional Electric Heat, Vertical Supply with MCHX Coil
50A3	VAV Unit with Optional Electric Heat, Vertical Supply with MCHX Coil
50A4	CV Unit with Optional Electric Heat, Horizontal Supply with MCHX Coil
50A5	VAV Unit with Optional Electric Heat, Horizontal Supply with MCHX Coil

**LEGEND**

- CV — Constant Volume
- MCHX — Microchannel Heat Exchanger
- VAV — Variable Air Volume

The A Series units provide ventilation, cooling, and heating (when equipped) in variable air volume (VAV), variable volume and temperature (VVT®), and constant volume (CV) applications. The A Series units contain the factory-installed *ComfortLink* control system which provides full system management. The main base board (MBB) stores hundreds of unit configuration settings and 8 time of day schedules. The MBB also performs self diagnostic tests at unit start-up, monitors the operation of the unit, and provides alarms and alert information. The system also contains other optional boards that are connected to the MBB through the Local Equipment Network (LEN). Information on system operation and status are sent to the MBB processor by various sensors and optional boards that are located at the unit. Access to the unit controls for configuration, set point selection, schedule creation, and service can be done through a unit-mounted scrolling marquee. Access can also be done through the Carrier Comfort Network® (CCN) system using the *ComfortVIEW™* software, the accessory *Navigator™* handheld display, or the *System Pilot™* interface.




The *ComfortLink* system controls all aspects of the rooftop. It controls the supply-fan motor, compressors, and economizers to maintain the proper temperature conditions. The controls also cycle condenser fans to maintain suitable head pressure. All VAV units are equipped with a standard VFD (variable frequency drive) for supply fan speed control and supply duct pressure control. The *ComfortLink* controls adjust the speed of the VFD based on a static pressure sensor input. Constant volume (CV) units can be equipped with optional VFD for staged air volume (SAV™) control. The indoor fan will operate at low speed for energy savings and high speed when required. In addition, the *ComfortLink* controls can raise or lower the building pressure using multiple power exhaust fans controlled from economizer damper position or from a building pressure sensor. The control safeties are continuously monitored to ensure safe operation under all conditions. Sensors include suction pressure transducers, discharge pressure transducers, and saturated condensing temperature sensors which allow for display of operational pressures and saturation temperatures.

A scheduling function, programmed by the user, controls the unit occupied/unoccupied schedule. Up to 8 different schedules can be programmed.

The controls also allow the service person to operate a quick test so that all the controlled components can be checked for proper operation.

**Conventions Used in This Manual** — The following conventions for discussing configuration points for the local display (scrolling marquee or Navigator accessory) will be used in this manual.

Point names will be written with the Mode name first, then any sub-modes, then the point name, each separated by an arrow symbol (→). Names will also be shown in bold and italics. As an example, the IAQ Economizer Override Position which is located in the Configuration mode, Indoor Air Quality Configuration sub-mode, and the Air Quality Set Points sub-sub-mode, would be written as ***Configuration*** → ***IAQ*** → ***IAQ.SP*** → ***IQ.O.P***. A list of point names can be found in Appendix A.

This path name will show the user how to navigate through the local display to reach the desired configuration. The user would scroll through the modes and submodes using the  and  keys. The arrow symbol in the path name represents pressing  to move into the next level of the menu structure.

When a value is included as part of the path name, it will be shown at the end of the path name after an equals sign. If the value represents a configuration setting, an explanation will be shown in parentheses after the value. As an example, ***Configuration*** → ***IAQ*** → ***AQ.CF*** → ***IQ.AC = 1*** (IAQ Analog Input).

Pressing the **ESCAPE** and **ENTER** keys simultaneously at any time will display an expanded text description of the four-character point name. The expanded description is shown in the local display tables (Appendix A).

The CCN point names are also referenced in the local display tables for users configuring the unit with CCN software instead of the local display. The CCN tables are located in Appendix B of this manual.

## BASIC CONTROL USAGE

**ComfortLink Controls** — The *ComfortLink* control system is a comprehensive unit-management system. The control system is easy to access, configure, diagnose and trouble-shoot.

The control is flexible, providing two types of constant volume cooling control sequences, two variable air volume cooling control sequences, and heating control sequences for two-stage electric and gas systems, and for multiple-stage gas heating, in both Occupied and Unoccupied schedule modes. This control also manages:

- VAV duct pressure (through optional VFD), with reset
- Building pressure through two different power exhaust schemes
- Condenser fan cycling for mild ambient head pressure control
- Space ventilation control, in Occupied and Unoccupied periods, using CO<sub>2</sub> sensors or external signals, with ventilation defined by damper position
- Smoke control functions
- Occupancy schedules
- Occupancy or start/stop sequences based on third party signals
- Alarm status and history and run time data
- Management of a complete unit service test sequence

System diagnostics are enhanced by the use of multiple external sensors for air temperatures, air pressures, refrigerant temperatures, and refrigerant pressures. Unit-mounted actuators provide digital feedback data to the unit control.

The *ComfortLink* control system is fully communicating and cable-ready for connection to the Carrier Comfort Network® (CCN) building management system. The control provides high-speed communications for remote monitoring via the Internet. Multiple units can be linked together (and to other *ComfortLink* control equipped units) using a 3-wire communication bus.

The *ComfortLink* control system is easy to access through the use of a unit-mounted display module. There is no need to bring a separate computer to this unit for start-up. Access to control menus is simplified by the ability to quickly select from 11 menus. A scrolling readout provides detailed explanations of control information. Only four, large, easy-to-use buttons are required to maneuver through the entire controls menu.

For added service flexibility, an accessory hand-held Navigator module is also available. This portable device has an extended communication cable that can be plugged into the unit's communication network either at the main control box or at the opposite end of the unit, at a remote modular plug. The Navigator display provides the same menu structure, control access and display data as is available at the unit-mounted scrolling marquee display.

**Scrolling Marquee** — This device is the standard interface used to access the control information, read sensor values, and test the unit. The scrolling marquee is located in the main control box. The scrolling marquee display is a 4-key, 4-character LED (light-emitting diode) display module. The display also contains an Alarm Status LED. See Fig. 1. The display is easy to operate using 4 buttons and a group of 11 LEDs that

indicate the following menu structures, referred to as modes (see Appendix A):

- Run Status
- Service Test
- Temperatures
- Pressures
- Set points
- Inputs
- Outputs
- Configuration
- Timeclock
- Operating Modes
- Alarms

Through the scrolling marquee, the user can access all of the inputs and outputs to check on their values and status, configure operating parameters plus evaluate the current decision status for operating modes. Because the A Series units are equipped with suction pressure and saturated condensing temperature transducers, the scrolling marquee can also display refrigerant circuit pressures typically obtained from service gages. The control also includes an alarm history which can be accessed from the display. In addition, through the scrolling marquee, the user can access a built-in test routine that can be used at start-up commissioning to diagnose operational problems with the unit.

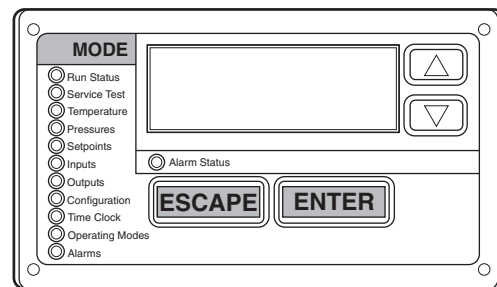


Fig. 1 — Scrolling Marquee

**Accessory Navigator™ Display** — The accessory hand-held Navigator display can be used with the A Series units. See Fig. 2. The Navigator display operates the same way as the scrolling marquee device. The Navigator display is plugged into the RJ-14 (LEN) jack in the main control box on the COMM board. The Navigator display can also be plugged into the RJ-14 jack located on the ECB (economizer control board) located in the auxiliary control box.

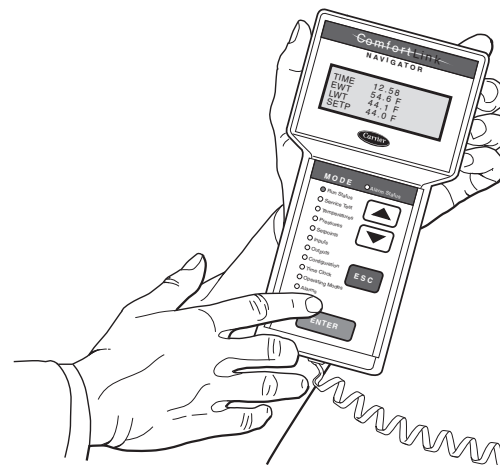


Fig. 2 — Accessory Navigator Display



**Operation** — All units are shipped from the factory with the scrolling marquee display, which is located in the main control box. See Fig. 1. In addition, the *ComfortLink* controls also support the use of the handheld Navigator display.

Both displays provide the user with an interface to the *ComfortLink* control system. The displays have ▲ and ▼ arrow keys, an **ESCAPE** key and an **ENTER** key. These keys are used to navigate through the different modes of the display structure. The Navigator and the scrolling marquee displays operate in the same manner, except that the Navigator display has multiple lines of display and the scrolling marquee has a single line. All further discussions and examples in this document will be based on the scrolling marquee display. See Table 2 for the menu structure.

The four keys are used to navigate through the display structure, which is organized in a tiered mode structure. If the buttons have not been used for a period, the display will default to the AUTO VIEW display category as shown under the RUN STATUS category. To show the top-level display, press the **ESCAPE** key until a blank display is shown. Then use the ▲ and ▼ arrow keys to scroll through the top-level categories (modes). These are listed in Appendix A and will be indicated on the scrolling marquee by the LED next to each mode listed on the face of the display.

When a specific mode or sub-mode is located, push the **ENTER** key to enter the mode. Depending on the mode, there may be additional tiers. Continue to use the ▲ and ▼ keys and the **ENTER** keys until the desired display item is found. At any time, the user can move back a mode level by pressing the **ESCAPE** key. Once an item has been selected the display will flash showing the item, followed by the item value and then followed by the item units (if any).

Items in the Configuration and Service Test modes are password protected. The display will flash PASS and WORD when required. Use the **ENTER** and arrow keys to enter the four digits of the password. The default password is 1111.

Pressing the **ESCAPE** and **ENTER** keys simultaneously will scroll an expanded text description across the display indicating the full meaning of each display point. Pressing the **ESCAPE** and **ENTER** keys when the display is blank (MODE LED level) will return the display to its default menu of rotating AUTO VIEW display items. In addition, the password will need to be entered again before changes can be made.

Changing item values or testing outputs is accomplished in the same manner. Locate and display the desired item. If the display is in rotating auto-view, press the **ENTER** key to stop the display at the desired item. Press the **ENTER** key again so that the item value flashes. Use the arrow keys to change the value of state of an item and press the **ENTER** key to accept it. Press the **ESCAPE** key and the item, value or units display will resume. Repeat the process as required for other items.

If the user needs to force a variable, follow the same process as when editing a configuration parameter. A forced variable

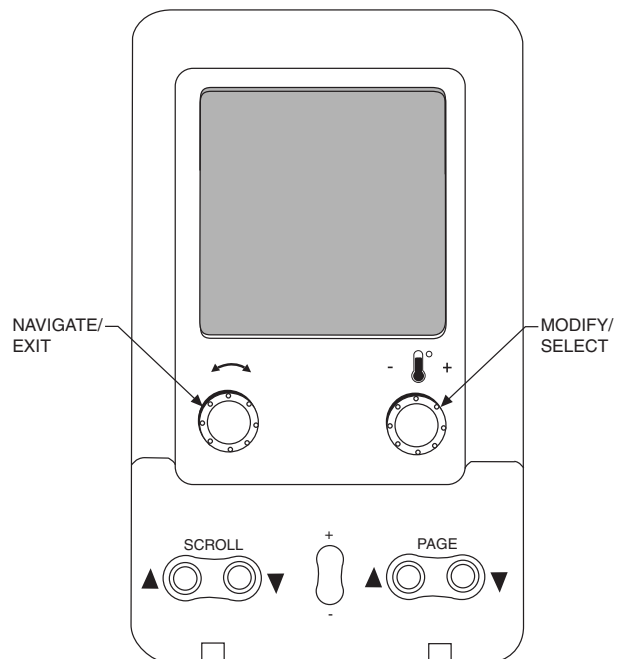
will be displayed with a blinking “f” following its value. For example, if supply fan requested (*FAN.F*) is forced, the display shows “YESf”, where the “f” is blinking to signify a force on the point. Remove the force by selecting the point that is forced with the **ENTER** key and then pressing the ▲ and ▼ arrow keys simultaneously.

Depending on the unit model, factory-installed options and field-installed accessories, some of the items in the various Mode categories may not apply.

**System Pilot™ Interface** — The System Pilot (33PILOT-01) device is a component of Carrier’s 3V™ system and serves as a user-interface and configuration tool for all Carrier communicating devices. The System Pilot device can be used to install and commission a 3V zoning system, linkage compatible air source, universal controller, and all other devices operating on the CCN system.

Additionally, the System Pilot device can serve as a wall-mounted temperature sensor for space temperature measurement. The occupant can use the System Pilot device to change set points. A security feature is provided to limit access of features for unauthorized users. See Fig. 3 for System Pilot details.

**CCN Tables and Display** — In addition to the unit-mounted scrolling marquee display, the user can also access the same information through the CCN tables by using the Service Tool or other CCN programs. Details on the CCN tables are summarized in Appendix B. The variable names used for the CCN tables and the scrolling marquee tables may be different and more items are displayed in the CCN tables. As a reference, the CCN variable names are included in the scrolling marquee tables and the scrolling marquee names are included in the local display tables in Appendix B.



**Fig. 3 — System Pilot™ User Interface**

**Table 2 — Scrolling Marquee Menu Display Structure  
(ComfortLink Display Modes)**

RUN STATUS	SERVICE TEST	TEMPERATURES	PRESSURES	SETPOINTS	INPUTS	OUTPUTS	CONFIGURATION	TIME CLOCK	OPERATING MODES	ALARMS
Auto View of Run Status (VIEW) ↓	Service Test Mode (TEST) ↓	Air Temperatures (AIR.T) ↓	Air Pressures (AIR.P) ↓	Occupied Heat Setpoint (OHSP) ↓	General Inputs (GEN.I) ↓	Fans (FANS) ↓	Unit Configuration (UNIT) ↓	Time of Day (TIME) ↓	System Mode (SYS.M) ↓	Currently Active Alarms (CURR) ↓
Econ Run Status (ECON) ↓	Software Command Disable (STOP) ↓	Refrigerant Temperatures (REF.T) ↓	Refrigerant Pressures (REF.P) ↓	Occupied Cool Setpoint (OCSP) ↓	Compressor Feedback (FD.BK) ↓	Cooling (COOL) ↓	Cooling Configuration (COOL) ↓	Month, Date, Day and Year (DATE) ↓	HVAC Mode (HVAC) ↓	Reset All Current Alarms (R.CUR) ↓
Cooling Information (COOL) ↓	Soft Stop Request (S.STP) ↓			Unoccupied Heat Setpoint (UHSP) ↓	Thermostat Inputs (STAT) ↓	Heating (HEAT) ↓	Evap/Discharge Temp. Reset (EDT.R) ↓	Local Time Schedule (SCH.L) ↓	Control Type (CTRL) ↓	Alarm History (HIST)
Mode Trip Helper (TRIP) ↓	Supply Fan Request (FAN.F) ↓			Unoccupied Cool Setpoint (UCSP) ↓	Fire-Smoke Modes (FIRE) ↓	Economizer (ECON) ↓	Heating Configuration (HEAT) ↓	Local Holiday Schedules (HOLL) ↓	Mode Controlling Unit (MODE)	
CCN Linkage (LINK) ↓	4 in. Filter Change Mode (F.4.CH) ↓			Heat - Cool Setpoint (GAP) ↓	Relative Humidity (REL.H) ↓	General Outputs (GEN.O)	Supply Static Press. Config. (SP) ↓	Daylight Savings Time (DAYS)		
Compressor Run Hours (HRS) ↓	Test Independent Outputs (INDP) ↓			VAV Occ Cool On (V.C.ON) ↓	Air Quality Sensors (AIR.Q) ↓		Economizer Configuration (ECON) ↓			
Compressor Starts (STRT) ↓	Test Fans (FANS) ↓			VAV Occ Cool Off (V.C.OF) ↓	Reset Inputs (RSET) ↓		Building Press. Configs (BP) ↓			
Timeguards (TMGD) ↓	Test Cooling (COOL) ↓			Supply Air Setpoint (SASP) ↓	4-20 Milliamp Inputs (4-20) ↓		Cool/Heat Setpt. Offsets (DLV.T) ↓			
Software Version Numbers (VERS)	Test Heating (HEAT)			Supply Air Setpoint Hi (SA.HI) ↓			Demand Limit Config. (DMD.L) ↓			
				Supply Air Setpoint Lo (SA.LO) ↓			Indoor Air Quality Cfg. (IAQ) ↓			
				Heating Supply Air Setpoint (SA.HT) ↓			Dehumidification Config. (DEHU) ↓			
				Tempering Purge SASP (T.PRG) ↓			CCN Configuration (CCN) ↓			
				Tempering in Cool SASP (T.CL) ↓			Alert Limit Config. (ALLM) ↓			
				Tempering in Vent Occ SASP (T.V.OC) ↓			Sensor Trim Config. (TRIM) ↓			
				Tempering in Vent Unocc. SASP (T.V.UN)			Switch Logic (SW.LG) ↓			
							Display Configuration (DISP)			

**GENERICS STATUS DISPLAY TABLE** — The GENERICS points table allows the service/installer the ability to create a custom table in which up to 20 points from the 5 CCN categories (Points, Config, Service-Config, Set Point, and Maintenance) may be collected and displayed.

In the Service-Config table section, there is a table named “generics.” This table contains placeholders for up to 20 CCN point names and allows the user to decide which points are displayed in the GENERICS points table under the local display. Each one of these placeholders allows the input of an 8-character ASCII string. Using a CCN interface, enter the Edit mode for the Service-Config table “generics” and enter the CCN name for each point to be displayed in the custom points table in the order they will be displayed. When done entering point names, download the table to the rooftop unit control.

**IMPORTANT:** The computer system software (ComfortVIEW™, Service Tool, etc.) that is used to interact with CCN controls always saves a template of items it considers as static (e.g., limits, units, forcibility, 24-character text strings, and point names) after the software uploads the tables from a control. Thereafter, the software is only concerned with run time data like value and hardware/force status. With this in mind, it is important that anytime a change is made to the Service-Config table “generics” (which in turn changes the points contained in the GENERICS point table), that a complete new upload be performed. **This requires that any previous table database be completely removed first.** Failure to do this will not allow the user to display the new points that have been created and the CCN interface will have a different table database than the unit control.

## START-UP

**IMPORTANT:** Do not attempt to start unit, even momentarily, until all items on the Start-Up Checklist and the following steps have been completed.

**Unit Preparation** — Check that unit has been installed in accordance with the installation instructions and applicable codes.

**Unit Setup** — Make sure that the economizer hoods have been installed and that the outdoor filters are properly installed.

**Internal Wiring** — Ensure that all electrical connections in the control box are tightened as required. If the unit has staged gas heat make sure that the leaving air temperature (LAT) sensors have been routed to the supply ducts as required.

**Accessory Installation** — Check to make sure that all accessories including space thermostats and sensors have been installed and wired as required by the instructions and unit wiring diagrams.

**Crankcase Heaters** — Crankcase heaters are energized as long as there is power to the unit, except when the compressors are running.

**IMPORTANT:** Unit power must be on for 24 hours prior to start-up of compressors. Otherwise damage to compressors may result.

**Evaporator Fan** — Fan belt and fixed pulleys are factory-installed. See Tables 3-38 for fan performance. Remove tape from fan pulley, and be sure that fans rotate in the proper direction. See Table 39 for motor limitations. See Tables 40A and 40B for air quantity limits. Static pressure drop for power exhaust is negligible. To alter fan performance, see Evaporator Fan Performance Adjustment section on page 131.

**Controls** — Use the following steps for the controls:

**IMPORTANT:** The unit is shipped with the unit control disabled. To enable the control, set Local Machine Disable (*Service Test* → *STOP*) to No.

1. Set any control configurations that are required (field-installed accessories, etc.). The unit is factory configured for all appropriate factory-installed options.
2. Enter unit set points. The unit is shipped with the set point default values. If a different set point is required use the scrolling marquee, Navigator™ accessory or Service Tool software to change the configuration valves.
3. If the internal unit schedules are going to be used configure the Occupancy schedule.
4. Verify that the control time periods programmed meet current requirements.
5. Using Service Test mode, verify operation of all major components.
6. If the unit is a VAV unit make sure to configure the VFD static pressure set point using the display. To checkout the VFD use the VFD instructions shipped with the unit.

**Gas Heat** — Verify gas pressure before turning on gas heat as follows:

1. Turn off field-supplied manual gas stop, located external to the unit.
2. Connect pressure gages to supply gas tap, located at field-supplied manual shutoff valves.
3. Connect pressure gages to manifold pressure tap on unit gas valve.
4. Supply gas pressure must not exceed 13.5 in. wg. Check pressure at field-supplied shut-off valve.
5. Turn on manual gas stop and initiate a heating demand. Jumper R to W1 in the control box to initiate heat.
6. Use the Service Test procedure to verify heat operation.
7. After the unit has run for several minutes, verify that incoming pressure is 6.0 in. wg or greater and that the manifold pressure is 3.5 in wg. If manifold pressure must be adjusted refer to Gas Valve Adjustment section.

**Table 3 — Fan Performance — 48AJ,AK020,025 and 48A2,A3020 Units**

AIRFLOW (CFM)	AVAILABLE EXTERNAL STATIC PRESSURE (in. wg)																			
	0.2		0.4		0.6		0.8		1.0		1.2		1.4		1.6		1.8		2.0	
	Rpm	Bhp	Rpm	Bhp	Rpm	Bhp	Rpm	Bhp	Rpm	Bhp	Rpm	Bhp	Rpm	Bhp	Rpm	Bhp	Rpm	Bhp	Rpm	Bhp
4,000	328	0.62	406	0.84	472	1.07	529	1.30	580	1.54	626	1.78	668	2.02	708	2.27	745	2.51	780	2.76
5,000	369	0.97	439	1.19	500	1.43	554	1.69	604	1.95	650	2.21	692	2.48	731	2.74	769	3.01	804	3.28
6,000	415	1.43	477	1.65	533	1.90	584	2.17	631	2.45	676	2.73	717	3.01	756	3.30	793	3.59	828	3.88
7,000	463	2.01	519	2.25	570	2.50	618	2.78	662	3.06	704	3.36	744	3.65	782	3.96	818	4.27	852	4.58
7,500	488	2.36	541	2.60	590	2.86	636	3.13	679	3.42	720	3.72	759	4.02	796	4.33	832	4.65	866	4.96
8,000	513	2.74	564	2.98	611	3.24	655	3.52	697	3.81	737	4.11	775	4.42	811	4.74	846	5.06	879	5.38
9,000	564	3.61	612	3.87	655	4.13	696	4.42	735	4.71	772	5.02	808	5.33	843	5.65	876	5.98	909	6.32
10,000	616	4.64	661	4.91	701	5.18	739	5.47	776	5.77	811	6.08	845	6.40	878	6.72	909	7.06	940	7.40
11,000	669	5.84	711	6.11	749	6.40	785	6.69	819	6.99	852	7.30	884	7.63	915	7.96	945	8.30	975	8.65
12,000	723	7.20	762	7.49	798	7.78	831	8.08	864	8.39	895	8.71	925	9.04	955	9.37	984	9.72	1012	10.07
12,500	750	7.95	788	8.25	823	8.54	855	8.85	887	9.16	917	9.48	947	9.81	976	10.15	1004	10.49	1031	10.84
13,000	777	8.75	814	9.05	848	9.35	880	9.66	910	9.97	940	10.30	969	10.63	997	10.97	1024	11.31	1051	11.67

AIRFLOW (CFM)	AVAILABLE EXTERNAL STATIC PRESSURE (in. wg)																			
	2.2		2.4		2.6		2.8		3.0		3.2		3.4		3.6		3.8		4.0	
	Rpm	Bhp	Rpm	Bhp	Rpm	Bhp	Rpm	Bhp	Rpm	Bhp	Rpm	Bhp	Rpm	Bhp	Rpm	Bhp	Rpm	Bhp	Rpm	Bhp
4,000	814	3.01	845	3.26	876	3.51	905	3.76	934	4.02	961	4.28	987	4.54	1013	4.80	1038	5.06	1062	5.32
5,000	837	3.55	869	3.82	900	4.10	929	4.37	958	4.64	985	4.92	1012	5.20	1038	5.48	1063	5.76	1087	6.04
6,000	861	4.17	893	4.46	923	4.76	953	5.05	981	5.35	1009	5.65	1036	5.94	1062	6.24	1087	6.54	1111	6.84
7,000	885	4.89	917	5.20	947	5.51	977	5.83	1005	6.14	1033	6.46	1059	6.78	1085	7.09	1110	7.41	1135	7.73
7,500	898	5.28	930	5.61	960	5.93	989	6.25	1017	6.58	1045	6.90	1071	7.23	1097	7.56	1122	7.88	1147	8.21
8,000	912	5.71	943	6.04	973	6.37	1002	6.70	1030	7.04	1057	7.37	1083	7.71	1109	8.04	1134	8.38	1159	8.72
9,000	940	6.66	970	7.00	999	7.35	1028	7.69	1055	8.04	1082	8.39	1109	8.75	1134	9.10	1159	9.45	1183	9.81
10,000	971	7.75	1000	8.10	1028	8.46	1056	8.82	1083	9.18	1109	9.54	1135	9.91	1160	10.28	1185	10.65	—	—
11,000	1004	9.00	1032	9.36	1059	9.73	1086	10.09	1112	10.46	1138	10.84	1163	11.22	1188	11.60	—	—	—	—
12,000	1039	10.42	1066	10.79	1093	11.16	1119	11.53	1144	11.91	1169	12.30	1193	12.68	—	—	—	—	—	—
12,500	1058	11.20	1085	11.57	1110	11.94	1136	12.32	1161	12.70	1185	13.09	—	—	—	—	—	—	—	—
13,000	1077	12.03	1103	12.40	1129	12.77	1154	13.15	1178	13.54	—	—	—	—	—	—	—	—	—	—

**Table 4 — Fan Performance — 48AJ,AK027,030 and 48A2,A3025-030 Units**

AIRFLOW (CFM)	AVAILABLE EXTERNAL STATIC PRESSURE (in. wg)																			
	0.2		0.4		0.6		0.8		1.0		1.2		1.4		1.6		1.8		2.0	
	Rpm	Bhp	Rpm	Bhp	Rpm	Bhp	Rpm	Bhp	Rpm	Bhp	Rpm	Bhp	Rpm	Bhp	Rpm	Bhp	Rpm	Bhp	Rpm	Bhp
4,000	331	0.63	408	0.85	474	1.08	531	1.31	581	1.55	627	1.79	670	2.03	709	2.28	746	2.52	781	2.77
5,000	374	0.98	443	1.20	503	1.45	558	1.70	607	1.96	653	2.23	695	2.49	734	2.76	771	3.03	806	3.30
6,000	421	1.45	482	1.68	538	1.93	589	2.20	636	2.47	680	2.75	721	3.04	759	3.33	796	3.62	831	3.91
7,000	471	2.04	526	2.28	576	2.54	623	2.81	668	3.10	710	3.39	749	3.69	787	4.00	823	4.31	857	4.62
8,000	522	2.78	572	3.03	619	3.29	662	3.57	704	3.86	743	4.16	781	4.47	817	4.79	851	5.11	885	5.44
9,000	574	3.66	621	3.92	664	4.19	704	4.47	743	4.77	780	5.08	815	5.40	850	5.72	883	6.05	915	6.39
10,000	628	4.71	671	4.97	711	5.25	748	5.54	784	5.84	819	6.15	853	6.47	885	6.81	917	7.14	948	7.49
11,000	682	5.91	722	6.19	759	6.48	795	6.77	828	7.08	861	7.40	893	7.72	924	8.06	954	8.40	983	8.75
12,000	736	7.30	774	7.59	809	7.88	842	8.18	874	8.49	905	8.82	935	9.15	965	9.48	993	9.83	1021	10.19
13,000	791	8.86	827	9.16	860	9.46	891	9.78	922	10.09	951	10.42	979	10.75	1007	11.10	1034	11.45	1061	11.80
14,000	846	10.61	880	10.93	912	11.24	941	11.56	970	11.88	998	12.21	1025	12.56	1052	12.90	1078	13.26	1103	13.62
15,000	902	12.56	934	12.89	964	13.21	992	13.54	1020	13.87	1046	14.21	1072	14.55	1098	14.91	1122	15.26	1147	15.63

AIRFLOW (CFM)	AVAILABLE EXTERNAL STATIC PRESSURE (in. wg)																			
	2.2		2.4		2.6		2.8		3.0		3.2		3.4		3.6		3.8		4.0	
	Rpm	Bhp	Rpm	Bhp	Rpm	Bhp	Rpm	Bhp	Rpm	Bhp	Rpm	Bhp	Rpm	Bhp	Rpm	Bhp	Rpm	Bhp	Rpm	Bhp
4,000	815	3.02	847	3.27	877	3.52	906	3.77	935	4.03	962	4.29	988	4.55	1014	4.81	1039	5.07	1063	5.33
5,000	839	3.57	871	3.84	902	4.11	931	4.39	960	4.66	987	4.94	1014	5.22	1039	5.50	1064	5.78	1089	6.06
6,000	864	4.20	896	4.49	926	4.79	956	5.08	984	5.38	1012	5.68	1038	5.97	1064	6.27	1089	6.57	1114	6.87
7,000	890	4.93	921	5.24	951	5.55	980	5.87	1009	6.18	1036	6.50	1063	6.82	1088	7.14	1114	7.45	1138	7.77
8,000	917	5.76	948	6.09	977	6.42	1006	6.76	1034	7.09	1061	7.43	1088	7.76	1113	8.10	1138	8.43	1163	8.77
9,000	946	6.73	976	7.07	1005	7.42	1033	7.76	1061	8.11	1088	8.46	1114	8.82	1139	9.17	1164	9.52	1188	9.88
10,000	978	7.84	1007	8.19	1035	8.55	1063	8.91	1089	9.27	1116	9.63	1141	10.00	1166	10.37	1191	10.74	—	—
11,000	1012	9.10	1040	9.47	1067	9.83	1094	10.20	1120	10.57	1145	10.95	1170	11.33	1195	11.71	—	—	—	—
12,000	1048	10.54	1075	10.91	1102	11.28	1127	11.66	1152	12.04	1177	12.42	—	—	—	—	—	—	—	—
13,000	1087	12.17	1113	12.54	1138	12.91	1163	13.30	1187	13.68	—	—	—	—	—	—	—	—	—	—
14,000	1128	13.98	1153	14.36	1177	14.74	—	—	—	—	—	—	—	—	—	—	—	—	—	—
15,000	1171	16.00	1194	16.38	—	—	—	—	—	—	—	—	—	—	—	—	—	—	—	—

**LEGEND**

**Bhp** — Brake Horsepower  
**edb** — Entering Dry Bulb  
**ewb** — Entering Wet Bulb

**NOTES:**

1. Fan performance is based on wet coils, economizer, roof curb, cabinet losses, and clean 2-in. filters.

2. Conversion — Bhp to watts:

$$\text{Watts} = \frac{\text{Bhp} \times 746}{\text{Motor efficiency}}$$

3. Variable air volume units will operate down to 70 cfm/ton. Performance at 70 cfm/ton is limited to unloaded operation and may be additionally limited by edb and ewb conditions.



**Table 5 — Fan Performance — 48AJ,AK,A2,A3035 Units**

AIRFLOW (Cfm)	AVAILABLE EXTERNAL STATIC PRESSURE (in. wg)																			
	0.2		0.4		0.6		0.8		1.0		1.2		1.4		1.6		1.8		2.0	
	Rpm	Bhp	Rpm	Bhp	Rpm	Bhp	Rpm	Bhp	Rpm	Bhp	Rpm	Bhp	Rpm	Bhp	Rpm	Bhp	Rpm	Bhp	Rpm	Bhp
7,000	534	2.46	584	2.90	630	3.13	674	3.48	716	3.82	756	4.16	793	4.50	829	4.83	863	5.17	896	5.49
8,000	590	3.27	635	3.63	677	3.99	718	4.35	757	4.72	794	5.08	830	5.45	864	5.81	897	6.18	929	6.54
9,000	646	4.23	687	4.62	726	5.00	764	5.38	800	5.76	835	6.15	869	6.54	902	6.93	934	7.31	964	7.70
10,000	704	5.35	742	5.77	778	6.17	812	6.57	846	6.97	879	7.38	911	7.78	942	8.19	972	8.60	1002	9.01
10,500	733	5.97	769	6.40	804	6.82	837	7.23	870	7.64	902	8.05	933	8.46	963	8.88	992	9.30	1021	9.72
11,000	762	6.63	797	7.08	830	7.51	863	7.93	894	8.35	925	8.77	955	9.19	984	9.62	1013	10.04	1041	10.47
12,000	820	8.09	853	8.56	884	9.01	915	9.46	944	9.90	973	10.34	1001	10.78	1029	11.22	1056	11.66	1083	12.10
13,000	879	9.72	909	10.22	939	10.70	968	11.17	996	11.63	1023	12.09	1050	12.55	1076	13.01	1102	13.46	1127	13.92
14,000	938	11.54	967	12.07	995	12.58	1022	13.07	1048	13.55	1074	14.03	1099	14.51	1124	14.98	1149	15.46	1173	15.93
15,000	997	13.56	1024	14.11	1051	14.64	1076	15.16	1102	15.67	1126	16.17	1150	16.66	1174	17.16	1197	17.65	1220	18.14
16,000	1056	15.78	1082	16.35	1107	16.91	1132	17.45	1156	17.98	1179	18.50	1202	19.02	1225	19.53	1247	20.04	1269	20.55
17,000	1116	18.20	1140	18.80	1164	19.38	1188	19.95	1210	20.50	1233	21.05	1255	21.58	1276	22.11	1298	22.64	—	—
17,500	1145	19.49	1170	20.10	1193	20.70	1216	21.28	1238	21.84	1260	22.40	1282	22.94	—	—	—	—	—	—

AIRFLOW (Cfm)	AVAILABLE EXTERNAL STATIC PRESSURE (in. wg)																			
	2.2		2.4		2.6		2.8		3.0		3.2		3.4		3.6		3.8		4.0	
	Rpm	Bhp	Rpm	Bhp	Rpm	Bhp	Rpm	Bhp	Rpm	Bhp	Rpm	Bhp	Rpm	Bhp	Rpm	Bhp	Rpm	Bhp	Rpm	Bhp
7,000	927	5.81	956	6.13	985	6.45	1012	6.76	1039	7.06	1065	7.37	1090	7.67	1114	7.97	1138	8.26	1161	8.56
8,000	960	6.89	989	7.25	1018	7.60	1045	7.94	1072	8.29	1098	8.63	1122	8.96	1147	9.29	1170	9.62	1193	9.95
9,000	994	8.09	1023	8.47	1051	8.85	1078	9.23	1104	9.61	1130	9.98	1155	10.35	1179	10.71	1203	11.08	1226	11.44
10,000	1030	9.42	1058	9.82	1085	10.23	1112	10.64	1138	11.04	1163	11.44	1188	11.84	1212	12.24	1235	12.64	1258	13.03
10,500	1049	10.14	1077	10.56	1103	10.97	1129	11.39	1155	11.81	1180	12.23	1204	12.64	1228	13.05	1251	13.46	1274	13.87
11,000	1069	10.90	1095	11.33	1122	11.76	1147	12.18	1173	12.61	1197	13.04	1221	13.47	1245	13.89	1268	14.31	1291	14.73
12,000	1109	12.55	1135	13.00	1160	13.44	1185	13.89	1209	14.34	1233	14.79	1256	15.24	1279	15.69	—	—	—	—
13,000	1152	14.38	1176	14.84	1200	15.31	1224	15.77	1248	16.24	1271	16.70	1293	17.17	—	—	—	—	—	—
14,000	1196	16.41	1220	16.88	1243	17.36	1266	17.84	1288	18.32	—	—	—	—	—	—	—	—	—	—
15,000	1243	18.63	1265	19.12	1287	19.61	—	—	—	—	—	—	—	—	—	—	—	—	—	—
16,000	1290	21.06	—	—	—	—	—	—	—	—	—	—	—	—	—	—	—	—	—	—
17,000	—	—	—	—	—	—	—	—	—	—	—	—	—	—	—	—	—	—	—	—
17,500	—	—	—	—	—	—	—	—	—	—	—	—	—	—	—	—	—	—	—	—

**Table 6 — Fan Performance — 48AJ,AK036 Units**

AIRFLOW (Cfm)	AVAILABLE EXTERNAL STATIC PRESSURE (in. wg)									
	0.2		0.4		0.6		0.8		1.0	
	Rpm	Bhp	Rpm	Bhp	Rpm	Bhp	Rpm	Bhp	Rpm	Bhp
7,000	454	2.15	508	2.52	557	2.90	605	3.29	650	3.69
8,000	502	2.90	550	3.30	596	3.71	639	4.12	680	4.54
9,000	552	3.81	595	4.24	637	4.67	677	5.11	715	5.55
10,000	602	4.89	642	5.34	680	5.80	717	6.26	752	6.73
11,000	653	6.15	689	6.62	725	7.11	759	7.59	792	8.08
12,000	704	7.60	738	8.09	771	8.60	803	9.11	834	9.63
13,000	756	9.24	788	9.76	818	10.29	848	10.83	878	11.36
14,000	808	11.10	838	11.64	867	12.19	895	12.74	922	13.30
15,000	861	13.18	888	13.74	915	14.31	942	14.88	968	15.46
16,000	914	15.49	940	16.06	965	16.65	990	17.24	1015	17.85
17,000	967	18.03	991	18.62	1015	19.23	1039	19.85	1062	20.47
17,500	993	19.40	1017	20.00	1040	20.61	1064	21.24	1086	21.87

AIRFLOW (Cfm)	AVAILABLE EXTERNAL STATIC PRESSURE (in. wg)									
	1.2		1.4		1.6		1.8		2.0	
	Rpm	Bhp	Rpm	Bhp	Rpm	Bhp	Rpm	Bhp	Rpm	Bhp
7,000	693	4.09	734	4.52	773	4.95	811	5.39	847	5.83
8,000	720	4.97	759	5.40	796	5.85	832	6.31	867	6.77
9,000	752	6.00	788	6.45	823	6.92	857	7.39	890	7.87
10,000	787	7.20	821	7.67	854	8.16	886	8.64	917	9.14
11,000	825	8.58	856	9.07	887	9.57	918	10.08	947	10.59
12,000	865	10.14	895	10.66	924	11.18	952	11.71	980	12.24
13,000	906	11.90	935	12.44	962	12.99	989	13.53	1016	14.08
14,000	950	13.87	976	14.43	1002	15.00	1028	15.57	1053	16.14
15,000	994	16.05	1019	16.63	1044	17.22	1068	17.81	1093	18.40
16,000	1039	18.45	1063	19.06	1087	19.67	1110	20.28	1133	20.89
17,000	1086	21.09	1109	21.72	1131	22.35	1153	22.98	1175	23.61
17,500	1109	22.50	1131	23.14	1154	23.78	1175	24.42	1197	25.07

AIRFLOW (Cfm)	AVAILABLE EXTERNAL STATIC PRESSURE (in. wg)									
	2.2		2.4		2.6		2.8		3.0	
	Rpm	Bhp	Rpm	Bhp	Rpm	Bhp	Rpm	Bhp	Rpm	Bhp
7,000	881	6.29	914	6.74	946	7.21	977	7.68	1006	8.15
8,000	901	7.24	933	7.72	965	8.20	995	8.69	1024	9.19
9,000	923	8.35	954	8.85	985	9.35	1014	9.86	1043	10.37
10,000	948	9.64	978	10.15	1007	10.66	1036	11.19	1064	11.71
11,000	976	11.11	1005	11.63	1033	12.16	1061	12.70	1088	13.24
12,000	1008	12.77	1035	13.31	1062	13.86	1088	14.41	1114	14.97
13,000	1042	14.64	1068	15.19	1093	15.76	1118	16.32	1143	16.89
14,000	1078	16.71	1103	17.28	1127	17.86	1151	18.45	1174	19.03
15,000	1116	19.00	1140	19.59	1163	20.19	1186	20.79	1208	21.40
16,000	1156	21.51	1178	22.12	1200	22.74	1222	23.36	1244	23.98
17,000	1197	24.25	1218	24.89	1240	25.52	1261	26.17	1281	26.81
17,500	1218	25.71	1239	26.36	1260	27.00	1280	27.66	—	—

AIRFLOW (Cfm)	AVAILABLE EXTERNAL STATIC PRESSURE (in. wg)									
	3.2		3.4		3.6		3.8		4.0	
	Rpm	Bhp	Rpm	Bhp	Rpm	Bhp	Rpm	Bhp	Rpm	Bhp
7,000	1035	8.63	1062	9.11	1089	9.60	1115	10.09	1140	10.58
8,000	1053	9.69	1081	10.19	1108	10.70	1134	11.21	1159	11.73
9,000	1072	10.89	1099	11.41	1126	11.94	1152	12.47	1177	13.00
10,000	1092	12.25	1119	12.78	1145	13.33	1171	13.88	1196	14.43
11,000	1114	13.79	1140	14.34	1166	14.90	1191	15.46	1216	16.03
12,000	1139	15.53	1164	16.09	1189	16.67	1213	17.24	1237	17.83
13,000	1167	17.47	1191	18.05	1215	18.64	1238	19.23	1262	19.82
14,000	1198	19.63	1221	20.22	1244	20.82	1266	21.43	1288	22.04
15,000	1230	22.00	1253	22.62	1274	23.23	1296	23.85	—	—
16,000	1265	24.61	1286	25.24	—	—	—	—	—	—
17,000	—	—	—	—	—	—	—	—	—	—
17,500	—	—	—	—	—	—	—	—	—	—

**LEGEND**  
**Bhp** — Brake Horsepower  
**edb** — Entering Dry Bulb  
**ewb** — Entering Wet Bulb

2. Conversion — Bhp to watts:

$$\text{Watts} = \frac{\text{Bhp} \times 746}{\text{Motor efficiency}}$$

**NOTES:**

1. Fan performance is based on wet coils, economizer, roof curb, cabinet losses, and clean 2-in. filters.

3. Variable air volume units will operate down to 70 cfm/ton. Performance at 70 cfm/ton is limited to unloaded operation and may be additionally limited by edb and ewb conditions.

**Table 7 — Fan Performance — 48AJ,AK,A2,A3040 Units**

AIRFLOW (Cfm)	AVAILABLE EXTERNAL STATIC PRESSURE (in. wg)																			
	0.2		0.4		0.6		0.8		1.0		1.2		1.4		1.6		1.8		2.0	
	Rpm	Bhp	Rpm	Bhp	Rpm	Bhp	Rpm	Bhp	Rpm	Bhp	Rpm	Bhp	Rpm	Bhp	Rpm	Bhp	Rpm	Bhp	Rpm	Bhp
8,000	502	2.90	550	3.30	596	3.71	639	4.12	680	4.54	720	4.97	759	5.40	796	5.85	832	6.31	867	6.77
9,000	552	3.81	595	4.24	637	4.67	677	5.11	715	5.55	752	6.00	788	6.45	823	6.92	857	7.39	890	7.87
10,000	602	4.89	642	5.34	680	5.80	717	6.26	752	6.73	787	7.20	821	7.67	854	8.16	886	8.64	917	9.14
11,000	653	6.15	689	6.62	725	7.11	759	7.59	792	8.08	825	8.58	856	9.07	887	9.57	918	10.08	947	10.59
12,000	704	7.60	738	8.09	771	8.60	803	9.11	834	9.63	865	10.14	895	10.66	924	11.18	952	11.71	980	12.24
13,000	756	9.24	788	9.76	818	10.29	848	10.83	878	11.36	906	11.90	935	12.44	962	12.99	989	13.53	1016	14.08
14,000	808	11.10	838	11.64	867	12.19	895	12.74	922	13.30	950	13.87	976	14.43	1002	15.00	1028	15.57	1053	16.14
15,000	861	13.18	888	13.74	915	14.31	942	14.88	968	15.46	994	16.05	1019	16.63	1044	17.22	1068	17.81	1093	18.40
16,000	914	15.49	940	16.06	965	16.65	990	17.24	1015	17.85	1039	18.45	1063	19.06	1087	19.67	1110	20.28	1133	20.89
17,000	967	18.03	991	18.62	1015	19.23	1039	19.85	1062	20.47	1086	21.09	1109	21.72	1131	22.35	1153	22.98	1175	23.61
18,000	1020	20.82	1043	21.43	1066	22.06	1088	22.69	1111	23.33	1133	23.97	1155	24.62	1176	25.27	1197	25.92	1219	26.58
19,000	1073	23.87	1095	24.50	1117	25.14	1138	25.79	1159	26.44	1180	27.11	1201	27.77	1222	28.45	1242	29.12	—	—
20,000	1127	27.18	1147	27.82	1168	28.48	1188	29.15	—	—	—	—	—	—	—	—	—	—	—	—

AIRFLOW (Cfm)	AVAILABLE EXTERNAL STATIC PRESSURE (in. wg)																			
	2.2		2.4		2.6		2.8		3.0		3.2		3.4		3.6		3.8		4.0	
	Rpm	Bhp	Rpm	Bhp	Rpm	Bhp	Rpm	Bhp	Rpm	Bhp	Rpm	Bhp	Rpm	Bhp	Rpm	Bhp	Rpm	Bhp	Rpm	Bhp
8,000	901	7.24	933	7.72	965	8.20	995	8.69	1024	9.19	1053	9.69	1081	10.19	1108	10.70	1134	11.21	1159	11.73
9,000	923	8.35	954	8.85	985	9.35	1014	9.86	1043	10.37	1072	10.89	1099	11.41	1126	11.94	1152	12.47	1177	13.00
10,000	948	9.64	978	10.15	1007	10.66	1036	11.19	1064	11.71	1092	12.25	1119	12.78	1145	13.33	1171	13.88	1196	14.43
11,000	976	11.11	1005	11.63	1033	12.16	1061	12.70	1088	13.24	1114	13.79	1140	14.34	1166	14.90	1191	15.46	1216	16.03
12,000	1008	12.77	1035	13.31	1062	13.86	1088	14.41	1114	14.97	1139	15.53	1164	16.09	1189	16.67	1213	17.24	1237	17.83
13,000	1042	14.64	1068	15.19	1093	15.76	1118	16.32	1143	16.89	1167	17.47	1191	18.05	1215	18.64	1238	19.23	1262	19.82
14,000	1078	16.71	1103	17.28	1127	17.86	1151	18.45	1174	19.03	1198	19.63	1221	20.22	1244	20.82	1266	21.43	1288	22.04
15,000	1116	19.00	1140	19.59	1163	20.19	1186	20.79	1208	21.40	1230	22.00	1253	22.62	1274	23.23	1296	23.85	—	—
16,000	1156	21.51	1178	22.12	1200	22.74	1222	23.36	1244	23.98	1265	24.61	1286	25.24	—	—	—	—	—	—
17,000	1197	24.25	1218	24.89	1240	25.52	1261	26.17	1281	26.81	—	—	—	—	—	—	—	—	—	—
18,000	1239	27.24	1260	27.89	1280	28.55	—	—	—	—	—	—	—	—	—	—	—	—	—	—
19,000	—	—	—	—	—	—	—	—	—	—	—	—	—	—	—	—	—	—	—	—
20,000	—	—	—	—	—	—	—	—	—	—	—	—	—	—	—	—	—	—	—	—

**Table 8 — Fan Performance — 48AJ,AK041 Units**

AIRFLOW (Cfm)	AVAILABLE EXTERNAL STATIC PRESSURE (in. wg)									
	0.2		0.4		0.6		0.8		1.0	
	Rpm	Bhp	Rpm	Bhp	Rpm	Bhp	Rpm	Bhp	Rpm	Bhp
8,000	502	2.90	550	3.30	596	3.71	639	4.12	680	4.54
9,000	552	3.81	595	4.24	637	4.67	677	5.11	715	5.55
10,000	602	4.89	642	5.34	680	5.80	717	6.26	752	6.73
11,000	653	6.15	689	6.62	725	7.11	759	7.59	792	8.08
12,000	704	7.60	738	8.09	771	8.60	803	9.11	834	9.63
13,000	756	9.24	788	9.76	818	10.29	848	10.83	878	11.36
14,000	808	11.10	838	11.64	867	12.19	895	12.74	922	13.30
15,000	861	13.18	888	13.74	915	14.31	942	14.88	968	15.46
16,000	914	15.49	940	16.06	965	16.65	990	17.24	1015	17.85
17,000	967	18.03	991	18.62	1015	19.23	1039	19.85	1062	20.47
18,000	1020	20.82	1043	21.43	1066	22.06	1088	22.69	1111	23.33
19,000	1073	23.87	1095	24.50	1117	25.14	1138	25.79	1159	26.44
20,000	1127	27.18	1147	27.82	1168	28.48	1188	29.15	—	—

AIRFLOW (Cfm)	AVAILABLE EXTERNAL STATIC PRESSURE (in. wg)									
	1.2		1.4		1.6		1.8		2.0	
	Rpm	Bhp	Rpm	Bhp	Rpm	Bhp	Rpm	Bhp	Rpm	Bhp
8,000	720	4.97	759	5.40	796	5.85	832	6.31	867	6.77
9,000	752	6.00	788	6.45	823	6.92	857	7.39	890	7.87
10,000	787	7.20	821	7.67	854	8.16	886	8.64	917	9.14
11,000	825	8.58	856	9.07	887	9.57	918	10.08	947	10.59
12,000	865	10.14	895	10.66	924	11.18	952	11.71	980	12.24
13,000	906	11.90	935	12.44	962	12.99	989	13.53	1016	14.08
14,000	950	13.87	976	14.43	1002	15.00	1028	15.57	1053	16.14
15,000	994	16.05	1019	16.63	1044	17.22	1068	17.81	1093	18.40
16,000	1039	18.45	1063	19.06	1087	19.67	1110	20.28	1133	20.89
17,000	1086	21.09	1109	21.72	1131	22.35	1153	22.98	1175	23.61
18,000	1133	23.97	1155	24.62	1176	25.27	1197	25.92	1219	26.58
19,000	1180	27.11	1201	27.77	1222	28.45	1242	29.12	—	—
20,000	—	—	—	—	—	—	—	—	—	—

AIRFLOW (Cfm)	AVAILABLE EXTERNAL STATIC PRESSURE (in. wg)									
	2.2		2.4		2.6		2.8		3.0	
	Rpm	Bhp	Rpm	Bhp	Rpm	Bhp	Rpm	Bhp	Rpm	Bhp
8,000	901	7.24	933	7.72	965	8.20	995	8.69	1024	9.19
9,000	923	8.35	954	8.85	985	9.35	1014	9.86	1043	10.37
10,000	948	9.64	978	10.15	1007	10.66	1036	11.19	1064	11.71
11,000	976	11.11	1005	11.63	1033	12.16	1061	12.70	1088	13.24
12,000	1008	12.77	1035	13.31	1062	13.86	1088	14.41	1114	14.97
13,000	1042	14.64	1068	15.19	1093	15.76	1118	16.32	1143	16.89
14,000	1078	16.71	1103	17.28	1127	17.86	1151	18.45	1174	19.03
15,000	1116	19.00	1140	19.59	1163	20.19	1186	20.79	1208	21.40
16,000	1156	21.51	1178	22.12	1200	22.74	1222	23.36	1244	23.98
17,000	1197	24.25	1218	24.89	1240	25.52	1261	26.17	1281	26.81
18,000	1239	27.24	1260	27.89	1280	28.55	—	—	—	—
19,000	—	—	—	—	—	—	—	—	—	—
20,000	—	—	—	—	—	—	—	—	—	—

AIRFLOW (Cfm)	AVAILABLE EXTERNAL STATIC PRESSURE (in. wg)									
	3.2		3.4		3.6		3.8		4.0	
	Rpm	Bhp	Rpm	Bhp	Rpm	Bhp	Rpm	Bhp	Rpm	Bhp
8,000	1053	9.69	1081	10.19	1108	10.70	1134	11.21	1159	11.73
9,000	1072	10.89	1099	11.41	1126	11.94	1152	12.47	1177	13.00
10,000	1092	12.25	1119	12.78	1145	13.33	1171	13.88	1196	14.43
11,000	1114	13.79	1140	14.34	1166	14.90	1191	15.46	1216	16.03
12,000	1139	15.53	1164	16.09	1189	16.67	1213	17.24	1237	17.83
13,000	1167	17.47	1191	18.05	1215	18.64	1238	19.23	1262	19.82
14,000	1198	19.63	1221	20.22	1244	20.82	1266	21.43	1288	22.04
15,000	1230	22.00	1253	22.62	1274	23.23	1296	23.85	—	—
16,000	1265	24.61	1286	25.24	—	—	—	—	—	—
17,000	—	—	—	—	—	—	—	—	—	—
18,000	—	—	—	—	—	—	—	—	—	—
19,000	—	—	—	—	—	—	—	—	—	—
20,000	—	—	—	—	—	—	—	—	—	—

**Table 9 — Fan Performance — 48AJ,AK,A2,A3050 Units**

AIRFLOW (Cfm)	AVAILABLE EXTERNAL STATIC PRESSURE (in. wg)																			
	0.2		0.4		0.6		0.8		1.0		1.2		1.4		1.6		1.8		2.0	
	Rpm	Bhp	Rpm	Bhp	Rpm	Bhp	Rpm	Bhp	Rpm	Bhp	Rpm	Bhp	Rpm	Bhp	Rpm	Bhp	Rpm	Bhp	Rpm	Bhp
8,000	512	2.98	560	3.38	604	3.79	647	4.20	688	4.62	728	5.05	766	5.49	803	5.94	839	6.40	874	6.86
9,000	561	3.90	604	4.33	645	4.77	685	5.20	723	5.65	760	6.10	796	6.55	831	7.02	864	7.49	897	7.97
10,000	611	5.00	651	5.45	689	5.91	725	6.37	761	6.84	795	7.31	829	7.79	861	8.27	893	8.76	925	9.26
11,000	662	6.27	699	6.75	734	7.23	768	7.72	801	8.21	833	8.71	865	9.20	895	9.71	925	10.21	955	10.73
12,000	714	7.74	748	8.24	780	8.75	812	9.26	843	9.77	873	10.29	903	10.81	932	11.33	960	11.86	988	12.39
13,000	766	9.41	798	9.93	828	10.46	858	11.00	887	11.54	916	12.08	944	12.62	971	13.16	998	13.71	1024	14.26
14,000	819	11.29	848	11.84	877	12.39	905	12.95	932	13.51	959	14.07	986	14.63	1012	15.20	1037	15.77	1062	16.34
15,000	872	13.40	899	13.96	926	14.54	953	15.11	979	15.70	1004	16.28	1029	16.87	1054	17.46	1078	18.05	1102	18.64
16,000	925	15.74	951	16.32	976	16.91	1001	17.51	1026	18.12	1050	18.72	1074	19.33	1097	19.94	1121	20.55	1143	21.17
17,000	979	18.32	1003	18.92	1027	19.53	1051	20.15	1074	20.77	1097	21.40	1120	22.03	1142	22.66	1164	23.29	1186	23.93
18,000	1032	21.15	1055	21.77	1078	22.40	1100	23.04	1123	23.68	1145	24.33	1166	24.98	1188	25.63	1209	26.28	1230	26.93
19,000	1086	24.24	1108	24.88	1129	25.52	1151	26.18	1172	26.84	1193	27.51	1214	28.18	1234	28.85	1255	29.52	1275	30.19
20,000	1140	27.60	1161	28.25	1181	28.92	1202	29.59	1222	30.27	1242	30.95	1262	31.64	1281	32.33	—	—	—	—

AIRFLOW (Cfm)	AVAILABLE EXTERNAL STATIC PRESSURE (in. wg)																			
	2.2		2.4		2.6		2.8		3.0		3.2		3.4		3.6		3.8		4.0	
	Rpm	Bhp	Rpm	Bhp	Rpm	Bhp	Rpm	Bhp	Rpm	Bhp	Rpm	Bhp	Rpm	Bhp	Rpm	Bhp	Rpm	Bhp	Rpm	Bhp
8,000	907	7.34	940	7.81	971	8.30	1001	8.79	1030	9.29	1059	9.79	1086	10.29	1113	10.80	1139	11.31	1164	11.83
9,000	930	8.46	961	8.95	991	9.46	1021	9.97	1050	10.48	1078	11.00	1105	11.52	1131	12.05	1157	12.58	1183	13.12
10,000	955	9.76	985	10.27	1014	10.79	1043	11.31	1071	11.84	1098	12.37	1125	12.91	1151	13.46	1177	14.01	1202	14.56
11,000	984	11.25	1012	11.77	1040	12.30	1068	12.84	1095	13.38	1121	13.93	1147	14.49	1172	15.05	1197	15.61	1222	16.18
12,000	1016	12.93	1043	13.47	1069	14.02	1095	14.57	1121	15.13	1147	15.69	1172	16.26	1196	16.83	1220	17.41	1244	18.00
13,000	1050	14.82	1076	15.38	1101	15.94	1126	16.51	1151	17.08	1176	17.66	1199	18.24	1223	18.83	1246	19.42	1269	20.02
14,000	1087	16.92	1111	17.49	1136	18.07	1159	18.66	1183	19.25	1206	19.84	1229	20.44	1252	21.04	1274	21.64	1296	22.25
15,000	1126	19.23	1149	19.83	1172	20.43	1195	21.03	1217	21.64	1239	22.25	1261	22.86	1283	23.48	—	—	—	—
16,000	1166	21.78	1188	22.40	1210	23.01	1232	23.64	1253	24.26	1275	24.89	1296	25.52	—	—	—	—	—	—
17,000	1208	24.56	1229	25.20	1250	25.84	1271	26.48	1291	27.12	—	—	—	—	—	—	—	—	—	—
18,000	1250	27.59	1271	28.25	1291	28.91	—	—	—	—	—	—	—	—	—	—	—	—	—	—
19,000	1294	30.87	—	—	—	—	—	—	—	—	—	—	—	—	—	—	—	—	—	—
20,000	—	—	—	—	—	—	—	—	—	—	—	—	—	—	—	—	—	—	—	—

**Table 10 — Fan Performance — 48AJ,AK051 Units**

AIRFLOW (Cfm)	AVAILABLE EXTERNAL STATIC PRESSURE (in. wg)									
	0.2		0.4		0.6		0.8		1.0	
	Rpm	Bhp	Rpm	Bhp	Rpm	Bhp	Rpm	Bhp	Rpm	Bhp
10,000	419	2.89	483	3.54	538	4.25	587	5.00	632	5.79
12,000	476	4.33	534	5.04	585	5.78	632	6.56	674	7.39
13,000	506	5.21	561	5.94	610	6.70	655	7.50	697	8.34
14,000	536	6.18	588	6.96	636	7.74	680	8.56	720	9.41
15,000	566	7.28	617	8.09	662	8.90	704	9.73	744	10.59
16,000	597	8.48	645	9.34	689	10.17	730	11.02	768	11.90
17,000	628	9.80	674	10.71	717	11.58	756	12.45	793	13.34
18,000	659	11.25	704	12.21	745	13.11	783	14.00	819	14.91
19,000	691	12.82	734	13.84	773	14.77	810	15.69	845	16.62
20,000	723	14.53	764	15.60	802	16.57	838	17.52	872	18.47
21,000	755	16.37	794	17.49	831	18.51	866	19.49	899	20.47
22,000	787	18.35	825	19.53	861	20.59	894	21.60	927	22.61
23,000	819	20.48	856	21.71	890	22.81	923	23.87	954	24.90
24,000	851	22.75	887	24.04	920	25.19	952	26.28	983	27.34
25,000	883	25.17	918	26.52	951	27.72	982	28.84	1011	29.94

AIRFLOW (Cfm)	AVAILABLE EXTERNAL STATIC PRESSURE (in. wg)									
	1.2		1.4		1.6		1.8		2.0	
	Rpm	Bhp	Rpm	Bhp	Rpm	Bhp	Rpm	Bhp	Rpm	Bhp
10,000	673	6.60	711	7.42	747	8.26	782	9.10	815	9.96
12,000	714	8.24	751	9.12	786	10.02	819	10.92	851	11.85
13,000	735	9.22	772	10.11	806	11.03	839	11.97	870	12.92
14,000	758	10.30	793	11.21	827	12.15	859	13.11	890	14.08
15,000	781	11.50	816	12.43	849	13.38	881	14.35	911	15.35
16,000	804	12.82	839	13.76	871	14.73	902	15.72	932	16.73
17,000	829	14.27	862	15.23	894	16.21	925	17.21	954	18.24
18,000	853	15.85	886	16.82	918	17.82	948	18.84	977	19.88
19,000	879	17.58	911	18.56	942	19.57	971	20.60	1000	21.65
20,000	905	19.44	936	20.44	966	21.45	995	22.50	1023	23.57
21,000	931	21.46	961	22.47	991	23.50	1019	24.55	1047	25.63
22,000	958	23.62	987	24.64	1016	25.69	1044	26.76	1071	27.84
23,000	985	25.93	1014	26.97	1042	28.03	1069	29.11	1096	30.21
24,000	1012	28.40	1041	29.46	1068	30.54	1095	31.63	1121	32.74
25,000	1040	31.02	1068	32.11	1095	33.21	1121	34.31	1147	35.44

AIRFLOW (Cfm)	AVAILABLE EXTERNAL STATIC PRESSURE (in. wg)									
	2.2		2.4		2.6		2.8		3.0	
	Rpm	Bhp	Rpm	Bhp	Rpm	Bhp	Rpm	Bhp	Rpm	Bhp
10,000	846	10.82	876	11.69	906	12.56	934	13.44	961	14.32
12,000	881	12.78	911	13.72	939	14.67	967	15.62	993	16.58
13,000	900	13.88	929	14.85	957	15.82	984	16.81	1011	17.80
14,000	920	15.06	948	16.06	976	17.07	1003	18.08	1029	19.11
15,000	940	16.36	968	17.38	996	18.41	1022	19.45	1048	20.50
16,000	961	17.76	989	18.80	1016	19.86	1042	20.92	1067	22.00
17,000	983	19.29	1010	20.34	1036	21.42	1062	22.51	1087	23.60
18,000	1005	20.94	1032	22.01	1058	23.11	1083	24.21	1108	25.33
19,000	1027	22.72	1054	23.81	1080	24.92	1105	26.04	1129	27.18
20,000	1050	24.65	1076	25.76	1102	26.88	1126	28.01	1151	29.17
21,000	1073	26.73	1099	27.84	1124	28.97	1149	30.13	1173	31.29
22,000	1097	28.95	1123	30.08	1147	31.22	1172	32.39	1195	33.56
23,000	1122	31.33	1147	32.47	1171	33.63	1195	34.80	—	—
24,000	1146	33.87	1171	35.02	1195	36.19	—	—	—	—
25,000	1171	36.58	1196	37.74	—	—	—	—	—	—

AIRFLOW (Cfm)	AVAILABLE EXTERNAL STATIC PRESSURE (in. wg)									
	3.2		3.4		3.6		3.8		4.0	
	Rpm	Bhp	Rpm	Bhp	Rpm	Bhp	Rpm	Bhp	Rpm	Bhp
10,000	988	15.21	1014	16.09	1039	16.98	1063	17.88	1087	18.77
12,000	1019	17.54	1045	18.51	1069	19.48	1093	20.45	1117	21.43
13,000	1036	18.80	1061	19.80	1086	20.81	1109	21.82	1133	22.84
14,000	1054	20.13	1079	21.17	1103	22.21	1126	23.26	1149	24.31
15,000	1073	21.56	1097	22.63	1121	23.70	1144	24.78	1167	25.86
16,000	1092	23.08	1116	24.17	1140	25.28	1162	26.38	1185	27.49
17,000	1112	24.71	1135	25.83	1159	26.95	1181	28.09	—	—
18,000	1132	26.46	1156	27.60	1178	28.74	—	—	—</	

**Table 11 — Fan Performance — 48AJ,AK,A2,A3060 Units**

AIRFLOW (Cfm)	AVAILABLE EXTERNAL STATIC PRESSURE (in. wg)																			
	0.2		0.4		0.6		0.8		1.0		1.2		1.4		1.6		1.8		2.0	
	Rpm	Bhp	Rpm	Bhp	Rpm	Bhp	Rpm	Bhp	Rpm	Bhp	Rpm	Bhp	Rpm	Bhp	Rpm	Bhp	Rpm	Bhp	Rpm	Bhp
12,000	476	4.33	534	5.04	585	5.78	632	6.56	674	7.39	714	8.24	751	9.12	786	10.02	819	10.93	851	11.85
14,000	536	6.19	588	6.96	636	7.74	680	8.56	720	9.41	758	10.30	793	11.21	827	12.15	859	13.11	890	14.08
15,000	566	7.28	617	8.09	662	8.90	704	9.73	744	10.59	781	11.50	816	12.42	849	13.38	881	14.36	911	15.35
16,000	597	8.48	645	9.34	689	10.17	730	11.02	768	11.90	804	12.82	839	13.76	871	14.73	902	15.72	932	16.73
17,000	628	9.80	674	10.71	717	11.58	756	12.45	793	13.34	829	14.27	862	15.23	894	16.21	925	17.21	954	18.24
18,000	659	11.25	704	12.21	745	13.11	783	14.00	819	14.91	853	15.85	886	16.82	918	17.82	948	18.84	977	19.88
19,000	691	12.82	734	13.84	773	14.77	810	15.69	845	16.62	879	17.58	911	18.56	942	19.57	971	20.60	1000	21.65
20,000	723	14.53	764	15.60	802	16.57	838	17.52	872	18.47	905	19.44	936	20.44	966	21.45	995	22.50	1023	23.57
21,000	755	16.37	794	17.49	831	18.51	866	19.49	899	20.47	931	21.46	961	22.47	991	23.50	1019	24.55	1047	25.63
22,000	787	18.35	825	19.53	861	20.59	894	21.60	927	22.61	958	23.62	987	24.64	1016	25.69	1044	26.76	1071	27.84
23,000	819	20.48	856	21.71	890	22.81	923	23.87	954	24.90	985	25.93	1014	26.97	1042	28.03	1069	29.11	1096	30.21
24,000	851	22.75	887	24.04	920	25.19	952	26.28	983	27.34	1012	28.40	1041	29.46	1068	30.54	1095	31.63	1121	32.74
25,000	883	25.17	918	26.52	951	27.72	982	28.84	1011	29.94	1040	31.02	1068	32.11	1095	33.21	1121	34.31	1147	35.44
26,000	916	27.76	950	29.15	981	30.40	1011	31.57	1040	32.70	1068	33.81	1095	34.92	1122	36.04	1147	37.16	1172	38.30
27,000	948	30.49	981	31.95	1012	33.24	1041	34.46	1070	35.62	1097	36.76	1123	37.90	1149	39.04	1174	40.18	1199	41.34

AIRFLOW (Cfm)	AVAILABLE EXTERNAL STATIC PRESSURE (in. wg)																			
	2.2		2.4		2.6		2.8		3.0		3.2		3.4		3.6		3.8		4.0	
	Rpm	Bhp	Rpm	Bhp	Rpm	Bhp	Rpm	Bhp	Rpm	Bhp	Rpm	Bhp	Rpm	Bhp	Rpm	Bhp	Rpm	Bhp	Rpm	Bhp
12,000	881	12.78	911	13.72	939	14.67	967	15.62	993	16.58	1019	17.54	1045	18.51	1069	19.48	1093	20.45	1117	21.43
14,000	920	15.06	948	16.06	976	17.07	1003	18.08	1029	19.11	1054	20.13	1079	21.17	1103	22.21	1126	23.26	1149	24.31
15,000	940	16.36	968	17.38	996	18.41	1022	19.45	1048	20.50	1073	21.56	1097	22.63	1121	23.70	1144	24.78	1167	25.86
16,000	961	17.76	989	18.80	1016	19.86	1042	20.92	1067	22.00	1092	23.08	1116	24.17	1140	25.28	1162	26.38	1185	27.49
17,000	983	19.28	1010	20.34	1036	21.42	1062	22.51	1087	23.60	1112	24.71	1135	25.83	1159	26.95	1181	28.09	—	—
18,000	1005	20.94	1032	22.01	1058	23.11	1083	24.21	1108	25.33	1132	26.46	1156	27.60	1178	28.74	—	—	—	—
19,000	1027	22.72	1054	23.81	1080	24.92	1105	26.04	1129	27.18	1153	28.33	1176	29.48	1199	30.65	—	—	—	—
20,000	1050	24.65	1076	25.76	1102	26.88	1126	28.01	1151	29.17	1174	30.33	1197	31.50	—	—	—	—	—	—
21,000	1073	26.73	1099	27.84	1124	28.97	1149	30.13	1173	31.29	1196	32.47	—	—	—	—	—	—	—	—
22,000	1097	28.95	1123	30.08	1147	31.22	1172	32.39	1195	33.56	—	—	—	—	—	—	—	—	—	—
23,000	1122	31.33	1147	32.47	1171	33.63	1195	34.80	—	—	—	—	—	—	—	—	—	—	—	—
24,000	1146	33.87	1171	35.02	1195	36.19	—	—	—	—	—	—	—	—	—	—	—	—	—	—
25,000	1171	36.58	1196	37.74	—	—	—	—	—	—	—	—	—	—	—	—	—	—	—	—
26,000	1197	39.46	—	—	—	—	—	—	—	—	—	—	—	—	—	—	—	—	—	—
27,000	—	—	—	—	—	—	—	—	—	—	—	—	—	—	—	—	—	—	—	—

**Table 12 — Fan Performance — 50AJ,AK020,025 and 50A2,A3020 Units**

AIRFLOW (CFM)	AVAILABLE EXTERNAL STATIC PRESSURE (in. wg)																			
	0.2		0.4		0.6		0.8		1.0		1.2		1.4		1.6		1.8		2.0	
	Rpm	Bhp	Rpm	Bhp	Rpm	Bhp	Rpm	Bhp	Rpm	Bhp	Rpm	Bhp	Rpm	Bhp	Rpm	Bhp	Rpm	Bhp	Rpm	Bhp
4,000	311	0.54	390	0.71	457	0.88	515	1.05	567	1.21	613	1.38	656	1.55	696	1.71	733	1.88	768	2.04
5,000	347	0.84	417	1.02	480	1.21	536	1.40	587	1.59	633	1.78	676	1.97	716	2.16	753	2.34	788	2.52
6,000	387	1.25	450	1.43	507	1.63	560	1.84	609	2.05	654	2.26	696	2.47	735	2.68	773	2.88	808	3.09
7,000	430	1.77	488	1.96	540	2.17	588	2.38	634	2.61	677	2.83	718	3.06	756	3.29	793	3.51	828	3.74
7,500	452	2.07	507	2.27	557	2.48	604	2.70	648	2.93	690	3.16	730	3.40	768	3.63	804	3.87	839	4.10
8,000	474	2.41	528	2.61	576	2.82	620	3.04	663	3.28	704	3.52	743	3.76	780	4.00	816	4.24	850	4.48
9,000	519	3.19	570	3.39	614	3.60	656	3.83	696	4.07	734	4.32	771	4.57	806	4.82	840	5.08	873	5.34
10,000	565	4.10	613	4.31	655	4.53	694	4.76	731	5.00	767	5.26	802	5.51	835	5.78	868	6.04	900	6.31
11,000	611	5.17	657	5.37	697	5.60	734	5.84	769	6.08	803	6.34	836	6.60	868	6.87	899	7.15	929	7.42
12,000	658	6.39	702	6.60	741	6.83	776	7.07	809	7.32	841	7.58	872	7.85	902	8.12	932	8.40	960	8.68
12,500	681	7.06	725	7.27	763	7.50	797	7.74	830	8.00	861	8.26	891	8.53	920	8.80	949	9.08	977	9.37
13,000	705	7.77	748	7.98	785	8.21	819	8.46	850	8.71	881	8.98	910	9.25	939	9.53	967	9.81	994	10.10

AIRFLOW (CFM)	AVAILABLE EXTERNAL STATIC PRESSURE (in. wg)																			
	2.2		2.4		2.6		2.8		3.0		3.2		3.4		3.6		3.8		4.0	
	Rpm	Bhp	Rpm	Bhp	Rpm	Bhp	Rpm	Bhp	Rpm	Bhp	Rpm	Bhp	Rpm	Bhp	Rpm	Bhp	Rpm	Bhp	Rpm	Bhp
4,000	802	2.21	833	2.38	864	2.55	893	2.71	921	2.88	949	3.06	975	3.23	1001	3.40	1026	3.58	1050	3.75
5,000	822	2.71	854	2.89	885	3.08	914	3.26	943	3.45	970	3.64	997	3.82	1023	4.01	1048	4.20	1072	4.39
6,000	842	3.29	874	3.50	905	3.70	934	3.90	963	4.10	991	4.31	1017	4.51	1043	4.71	1069	4.91	1093	5.12
7,000	862	3.96	894	4.19	924	4.41	954	4.63	983	4.85	1010	5.07	1037	5.29	1063	5.51	1089	5.72	1113	5.94
7,500	872	4.33	904	4.56	934	4.79	964	5.02	993	5.25	1020	5.48	1047	5.71	1073	5.94	1099	6.16	1123	6.39
8,000	883	4.73	914	4.97	945	5.21	974	5.45	1003	5.68	1030	5.92	1057	6.16	1083	6.39	1108	6.63	1133	6.87
9,000	905	5.60	936	5.85	966	6.11	995	6.37	1023	6.62	1051	6.88	1077	7.13	1103	7.38	1129	7.64	1153	7.89
10,000	931	6.58	961	6.85	990	7.13	1018	7.40	1046	7.67	1073	7.94	1099	8.21	1124	8.48	1149	8.75	1174	9.02
11,000	958	7.70	987	7.99	1015	8.27	1043	8.55	1070	8.84	1096	9.12	1122	9.41	1147	9.69	1171	9.98	1195	10.26
12,000	989	8.97	1016	9.26	1043	9.55	1070	9.85	1096	10.14	1121	10.44	1146	10.73	1171	11.03	1195	11.33	—	—
12,500	1005	9.66	1032	9.95	1058	10.25	1084	10.55	1110	10.85	1135	11.15	1159	11.45	1183	11.75	—	—	—	—
13,000	1021	10.39	1048	10.69	1074	10.99	1099	11.29	1124	11.59	1149	11.90	1173	12.20	1197	12.51	—	—	—	—

**LEGEND**  
**Bhp** — Brake Horsepower  
**edb** — Entering Dry Bulb  
**ewb** — Entering Wet Bulb

**NOTES:**

1. Fan performance is based on wet coils, economizer, roof curb, cabinet losses, and clean 2-in. filters.

2. Conversion — Bhp to watts:

$$\text{Watts} = \frac{\text{Bhp} \times 746}{\text{Motor efficiency}}$$

3. Variable air volume units will operate down to 70 cfm/ton. Performance at 70 cfm/ton is limited to unloaded operation and may be additionally limited by edb and ewb conditions.

**Table 13 — Fan Performance — 50AJ,AK027,030 and 50A2,A3025-030 Units**

AIRFLOW (CFM)	AVAILABLE EXTERNAL STATIC PRESSURE (in. wg)																			
	0.2		0.4		0.6		0.8		1.0		1.2		1.4		1.6		1.8		2.0	
	Rpm	Bhp	Rpm	Bhp	Rpm	Bhp	Rpm	Bhp	Rpm	Bhp	Rpm	Bhp	Rpm	Bhp	Rpm	Bhp	Rpm	Bhp	Rpm	Bhp
4,000	314	0.54	394	0.72	460	0.89	517	1.05	569	1.22	615	1.39	658	1.55	697	1.72	734	1.88	769	2.05
5,000	352	0.85	422	1.03	484	1.22	540	1.42	590	1.61	636	1.79	678	1.98	718	2.17	755	2.35	791	2.54
6,000	394	1.26	456	1.45	513	1.65	565	1.86	613	2.07	658	2.28	700	2.49	739	2.70	776	2.90	811	3.11
7,000	438	1.79	495	1.98	546	2.19	594	2.41	640	2.64	682	2.86	723	3.09	761	3.32	798	3.54	833	3.77
8,000	483	2.44	536	2.64	583	2.85	628	3.08	670	3.32	710	3.55	749	3.80	786	4.04	821	4.28	855	4.52
9,000	530	3.23	579	3.43	623	3.65	664	3.88	704	4.12	741	4.37	778	4.62	813	4.88	847	5.13	880	5.39
10,000	577	4.15	624	4.36	665	4.58	703	4.82	740	5.06	776	5.32	810	5.58	843	5.84	876	6.11	907	6.38
11,000	625	5.22	669	5.44	708	5.67	744	5.91	779	6.16	813	6.41	845	6.68	877	6.95	907	7.22	937	7.50
12,000	674	6.45	715	6.67	753	6.90	787	7.15	820	7.40	851	7.67	882	7.93	912	8.21	941	8.49	970	8.78
13,000	722	7.85	762	8.07	798	8.30	831	8.55	862	8.81	892	9.08	921	9.35	950	9.63	977	9.92	1005	10.21
14,000	771	9.41	810	9.64	844	9.88	875	10.13	905	10.39	934	10.66	962	10.94	989	11.22	1015	11.51	1041	11.81
15,000	821	11.15	857	11.38	890	11.62	921	11.88	949	12.14	977	12.42	1004	12.70	1030	12.99	1055	13.28	1080	13.58

AIRFLOW (CFM)	AVAILABLE EXTERNAL STATIC PRESSURE (in. wg)																			
	2.2		2.4		2.6		2.8		3.0		3.2		3.4		3.6		3.8		4.0	
	Rpm	Bhp	Rpm	Bhp	Rpm	Bhp	Rpm	Bhp	Rpm	Bhp	Rpm	Bhp	Rpm	Bhp	Rpm	Bhp	Rpm	Bhp	Rpm	Bhp
4,000	803	2.22	835	2.38	865	2.55	894	2.72	923	2.89	950	3.06	976	3.24	1002	3.41	1027	3.58	1051	3.76
5,000	824	2.72	856	2.91	887	3.09	916	3.28	945	3.46	972	3.65	999	3.83	1024	4.02	1049	4.21	1074	4.40
6,000	845	3.31	877	3.52	908	3.72	937	3.92	966	4.12	993	4.32	1020	4.53	1046	4.73	1071	4.93	1096	5.14
7,000	866	3.99	898	4.21	928	4.43	958	4.66	986	4.88	1014	5.10	1041	5.31	1067	5.53	1092	5.75	1116	5.97
8,000	888	4.77	919	5.01	950	5.25	979	5.49	1007	5.72	1035	5.96	1061	6.20	1087	6.43	1113	6.67	1137	6.90
9,000	912	5.65	942	5.90	972	6.16	1001	6.42	1029	6.67	1056	6.93	1083	7.18	1108	7.43	1134	7.69	1158	7.94
10,000	938	6.65	968	6.92	997	7.19	1025	7.46	1052	7.73	1079	8.00	1105	8.27	1130	8.54	1155	8.81	1180	9.08
11,000	967	7.78	995	8.07	1023	8.35	1051	8.63	1077	8.92	1103	9.20	1129	9.49	1154	9.77	1178	10.06	—	—
12,000	998	9.07	1025	9.35	1052	9.65	1078	9.94	1104	10.24	1130	10.54	1154	10.83	1179	11.13	—	—	—	—
13,000	1031	10.50	1058	10.80	1083	11.10	1109	11.40	1133	11.71	1158	12.01	1182	12.32	—	—	—	—	—	—
14,000	1067	12.10	1092	12.41	1117	12.71	1141	13.02	1165	13.33	1188	13.65	—	—	—	—	—	—	—	—
15,000	1104	13.88	1128	14.19	1152	14.50	1175	14.81	1198	15.13	—	—	—	—	—	—	—	—	—	—

**Table 14 — Fan Performance — 50AJ,AKA2,A3035 Units**

AIRFLOW (Cfm)	AVAILABLE EXTERNAL STATIC PRESSURE (in. wg)																			
	0.2		0.4		0.6		0.8		1.0		1.2		1.4		1.6		1.8		2.0	
	Rpm	Bhp	Rpm	Bhp	Rpm	Bhp	Rpm	Bhp	Rpm	Bhp	Rpm	Bhp	Rpm	Bhp	Rpm	Bhp	Rpm	Bhp	Rpm	Bhp
7,000	503	1.96	553	2.22	601	2.47	646	2.72	689	2.97	730	3.22	768	3.46	804	3.70	839	3.94	872	4.17
8,000	553	2.62	599	2.89	643	3.16	684	3.43	724	3.70	763	3.97	799	4.23	834	4.50	868	4.76	901	5.02
9,000	605	3.39	647	3.68	687	3.97	726	4.26	763	4.55	798	4.83	833	5.12	867	5.40	899	5.68	930	5.96
10,000	657	4.29	696	4.61	733	4.91	769	5.22	803	5.52	837	5.82	870	6.12	901	6.42	932	6.72	962	7.02
10,500	684	4.80	721	5.12	757	5.43	791	5.75	825	6.06	857	6.37	889	6.68	920	6.98	950	7.29	979	7.60
11,000	710	5.33	747	5.66	781	5.99	814	6.31	847	6.63	878	6.95	909	7.26	939	7.58	968	7.89	997	8.21
12,000	764	6.52	798	6.86	830	7.21	861	7.54	891	7.88	921	8.21	950	8.54	978	8.87	1006	9.20	1033	9.53
13,000	818	7.85	849	8.21	880	8.57	909	8.92	938	9.27	966	9.62	993	9.97	1020	10.31	1046	10.66	1072	11.00
14,000	872	9.33	901	9.71	930	10.09	958	10.45	985	10.82	1012	11.19	1037	11.55	1063	11.91	1088	12.27	1113	12.63
15,000	926	10.98	954	11.37	981	11.76	1008	12.15	1033	12.53	1059	12.91	1083	13.28	1108	13.66	1131	14.03	1155	14.40
16,000	980	12.79	1007	13.20	1033	13.60	1058	14.00	1082	14.40	1106	14.79	1130	15.18	1153	15.57	1176	15.96	1199	16.35
17,000	1035	14.77	1060	15.19	1085	15.61	1109	16.03	1132	16.44	1155	16.84	1178	17.25	1200	17.65	1222	18.05	1243	18.46
17,500	1062	15.83	1087	16.25	1111	16.68	1134	17.10	1157	17.52	1180	17.94	1202	18.35	1224	18.76	1245	19.17	1266	19.58

AIRFLOW (Cfm)	AVAILABLE EXTERNAL STATIC PRESSURE (in. wg)																			
	2.2		2.4		2.6		2.8		3.0		3.2		3.4		3.6		3.8		4.0	
	Rpm	Bhp	Rpm	Bhp	Rpm	Bhp	Rpm	Bhp	Rpm	Bhp	Rpm	Bhp	Rpm	Bhp	Rpm	Bhp	Rpm	Bhp	Rpm	Bhp
7,000	903	4.40	933	4.62	962	4.84	990	5.06	1017	5.27	1043	5.48	1068	5.69	1092	5.89	1116	6.09	1139	6.28
8,000	932	5.27	962	5.52	991	5.77	1019	6.02	1045	6.26	1071	6.50	1097	6.73	1121	6.96	1145	7.19	1168	7.42
9,000	961	6.24	990	6.52	1019	6.79	1047	7.06	1073	7.33	1099	7.59	1125	7.85	1149	8.11	1173	8.37	1196	8.62
10,000	992	7.32	1020	7.62	1048	7.91	1075	8.20	1102	8.49	1127	8.78	1152	9.07	1177	9.35	1201	9.63	1224	9.91
10,500	1008	7.90	1036	8.21	1063	8.51	1090	8.82	1116	9.12	1142	9.41	1166	9.71	1191	10.01	1214	10.30	1238	10.59
11,000	1025	8.52	1052	8.84	1079	9.15	1105	9.46	1131	9.77	1156	10.08	1181	10.39	1205	10.69	1228	10.99	1252	11.29
12,000	1060	9.86	1086	10.19	1112	10.52	1137	10.85	1162	11.17	1187	11.50	1211	11.82	1234	12.15	1257	12.47	1280	12.79
13,000	1097	11.35	1122	11.69	1147	12.03	1171	12.37	1195	12.72	1219	13.06	1242	13.40	1265	13.74	1287	14.08	—	—
14,000	1137	12.98	1161	13.34	1184	13.69	1208	14.05	1231	14.41	1253	14.76	1276	15.12	1298	15.47	—	—	—	—
15,000	1178	14.77	1201	15.15	1223	15.51	1246	15.88	1268	16.25	1289	16.62	—	—	—	—	—	—	—	—
16,000	1221	16.73	1243	17.11	1264	17.50	1286	17.88	—	—	—	—	—	—	—	—	—	—	—	—
17,000	1265	18.85	1286	19.25	—	—	—	—	—	—	—	—	—	—	—	—	—	—	—	—
17,500	1287	19.98	—	—	—	—	—	—	—	—	—	—	—	—	—	—	—	—	—	—

**LEGEND**

- Bhp** — Brake Horsepower
- edb** — Entering Dry Bulb
- ewb** — Entering Wet Bulb

**NOTES:**

1. Fan performance is based on wet coils, economizer, roof curb, cabinet losses, and clean 2-in. filters.

2. Conversion — Bhp to watts:

$$\text{Watts} = \frac{\text{Bhp} \times 746}{\text{Motor efficiency}}$$

3. Variable air volume units will operate down to 70 cfm/ton. Performance at 70 cfm/ton is limited to unloaded operation and may be additionally limited by edb and ewb conditions.



**Table 15 — Fan Performance — 50AJ,AK036 Units**

AIRFLOW (Cfm)	AVAILABLE EXTERNAL STATIC PRESSURE (in. wg)									
	0.2		0.4		0.6		0.8		1.0	
	Rpm	Bhp	Rpm	Bhp	Rpm	Bhp	Rpm	Bhp	Rpm	Bhp
7,000	431	1.99	484	2.35	534	2.72	580	3.08	625	3.46
8,000	475	2.69	523	3.08	569	3.47	612	3.86	653	4.26
9,000	521	3.53	565	3.94	606	4.36	646	4.78	684	5.20
10,000	568	4.52	608	4.96	646	5.40	683	5.84	719	6.29
11,000	615	5.68	652	6.14	687	6.60	722	7.07	755	7.55
12,000	663	7.01	697	7.49	730	7.98	762	8.47	794	8.97
13,000	712	8.53	743	9.03	774	9.54	804	10.05	834	10.57
14,000	760	10.24	790	10.76	819	11.29	847	11.82	875	12.36
15,000	809	12.15	837	12.69	864	13.24	891	13.79	917	14.35
16,000	859	14.27	885	14.83	910	15.40	936	15.97	960	16.55
17,000	908	16.61	933	17.19	957	17.77	981	18.36	1004	18.96
17,500	933	17.87	957	18.45	981	19.04	1004	19.64	1027	20.25

AIRFLOW (Cfm)	AVAILABLE EXTERNAL STATIC PRESSURE (in. wg)									
	1.2		1.4		1.6		1.8		2.0	
	Rpm	Bhp	Rpm	Bhp	Rpm	Bhp	Rpm	Bhp	Rpm	Bhp
7,000	667	3.85	707	4.24	746	4.65	783	5.07	819	5.49
8,000	692	4.66	730	5.07	767	5.49	802	5.92	836	6.36
9,000	721	5.63	757	6.06	791	6.49	825	6.94	857	7.39
10,000	753	6.74	787	7.20	819	7.65	851	8.11	882	8.58
11,000	788	8.02	819	8.50	850	8.97	880	9.46	909	9.94
12,000	824	9.47	854	9.96	883	10.47	912	10.97	939	11.48
13,000	862	11.09	891	11.61	918	12.13	945	12.66	972	13.19
14,000	902	12.90	929	13.45	955	13.99	981	14.54	1006	15.09
15,000	943	14.91	968	15.48	993	16.04	1018	16.62	1042	17.18
16,000	985	17.13	1009	17.71	1033	18.30	1056	18.89	1079	19.48
17,000	1028	19.56	1051	20.16	1073	20.77	1096	21.38	1118	21.99
17,500	1049	20.86	1072	21.47	1094	22.09	1116	22.71	1137	23.33

AIRFLOW (Cfm)	AVAILABLE EXTERNAL STATIC PRESSURE (in. wg)									
	2.2		2.4		2.6		2.8		3.0	
	Rpm	Bhp	Rpm	Bhp	Rpm	Bhp	Rpm	Bhp	Rpm	Bhp
7,000	854	5.93	887	6.37	919	6.82	950	7.28	980	7.74
8,000	870	6.81	902	7.26	933	7.73	964	8.20	993	8.67
9,000	889	7.85	920	8.31	950	8.79	979	9.27	1008	9.75
10,000	912	9.05	941	9.53	970	10.02	998	10.51	1026	11.00
11,000	938	10.43	966	10.92	993	11.42	1020	11.93	1047	12.44
12,000	967	11.98	993	12.49	1020	13.01	1046	13.53	1071	14.05
13,000	998	13.72	1023	14.25	1049	14.78	1073	15.32	1098	15.86
14,000	1031	15.64	1055	16.19	1079	16.75	1103	17.30	1126	17.86
15,000	1066	17.76	1089	18.33	1112	18.90	1135	19.48	1157	20.06
16,000	1102	20.08	1124	20.67	1147	21.26	1168	21.86	1190	22.46
17,000	1140	22.61	1161	23.22	1182	23.84	1203	24.45	1224	25.07
17,500	1159	23.95	1180	24.58	1201	25.21	1221	25.83	1242	26.46

AIRFLOW (Cfm)	AVAILABLE EXTERNAL STATIC PRESSURE (in. wg)									
	3.2		3.4		3.6		3.8		4.0	
	Rpm	Bhp	Rpm	Bhp	Rpm	Bhp	Rpm	Bhp	Rpm	Bhp
7,000	1009	8.21	1037	8.69	1064	9.17	1091	9.65	1116	10.14
8,000	1022	9.16	1050	9.65	1077	10.14	1104	10.64	1129	11.15
9,000	1036	10.25	1064	10.75	1090	11.26	1117	11.77	1142	12.29
10,000	1053	11.51	1080	12.02	1106	12.54	1131	13.06	1157	13.59
11,000	1073	12.95	1099	13.47	1124	14.00	1149	14.53	1173	15.07
12,000	1096	14.58	1121	15.11	1145	15.65	1169	16.19	1192	16.74
13,000	1121	16.40	1145	16.95	1168	17.50	1191	18.06	1214	18.62
14,000	1149	18.42	1172	18.98	1195	19.55	1217	20.12	1239	20.69
15,000	1179	20.63	1201	21.21	1223	21.80	1244	22.38	1265	22.97
16,000	1211	23.06	1232	23.66	1253	24.26	1274	24.86	1294	25.46
17,000	1245	25.69	1265	26.31	1285	26.93	—	—	—	—
17,500	1262	27.09	1282	27.71	—	—	—	—	—	—

**Table 16 — Fan Performance — 50AJ,AK,A2,A3040 Units**

AIRFLOW (Cfm)	AVAILABLE EXTERNAL STATIC PRESSURE (in. wg)																			
	0.2		0.4		0.6		0.8		1.0		1.2		1.4		1.6		1.8		2.0	
	Rpm	Bhp	Rpm	Bhp	Rpm	Bhp	Rpm	Bhp	Rpm	Bhp	Rpm	Bhp	Rpm	Bhp	Rpm	Bhp	Rpm	Bhp	Rpm	Bhp
8,000	475	2.69	523	3.08	569	3.47	612	3.86	653	4.26	692	4.66	730	5.07	767	5.49	802	5.92	836	6.36
9,000	521	3.53	565	3.94	606	4.36	646	4.78	684	5.20	721	5.63	757	6.06	791	6.49	825	6.94	857	7.39
10,000	568	4.52	608	4.96	646	5.40	683	5.84	719	6.29	753	6.74	787	7.20	819	7.65	851	8.11	882	8.58
11,000	615	5.68	652	6.14	687	6.60	722	7.07	755	7.55	788	8.02	819	8.50	850	8.97	880	9.46	909	9.94
12,000	663	7.01	697	7.49	730	7.98	762	8.47	794	8.97	824	9.47	854	9.96	883	10.47	912	10.97	939	11.48
13,000	712	8.53	743	9.03	774	9.54	804	10.05	834	10.57	862	11.09	891	11.61	918	12.13	945	12.66	972	13.19
14,000	760	10.24	790	10.76	819	11.29	847	11.82	875	12.36	902	12.90	929	13.45	955	13.99	981	14.54	1006	15.09
15,000	809	12.15	837	12.69	864	13.24	891	13.79	917	14.35	943	14.91	968	15.48	993	16.04	1018	16.62	1042	17.18
16,000	859	14.27	885	14.83	910	15.40	936	15.97	960	16.55	985	17.13	1009	17.71	1033	18.30	1056	18.89	1079	19.48
17,000	908	16.61	933	17.19	957	17.77	981	18.36	1004	18.96	1028	19.56	1051	20.16	1073	20.77	1096	21.38	1118	21.99
18,000	958	19.18	981	19.77	1004	20.37	1027	20.98	1049	21.60	1071	22.22	1093	22.84	1115	23.46	1136	24.09	1157	24.72
19,000	1007	21.98	1030	22.59	1052	23.21	1073	23.84	1095	24.47	1116	25.10	1137	25.74	1157	26.39	1178	27.04	1198	27.68
20,000	1057	25.02	1079	25.65	1099	26.29	1120	26.93	1140	27.58	1161	28.23	1181	28.89	—	—	—	—	—	—

AIRFLOW (Cfm)	AVAILABLE EXTERNAL STATIC PRESSURE (in. wg)																			
	2.2		2.4		2.6		2.8		3.0		3.2		3.4		3.6		3.8		4.0	
	Rpm	Bhp	Rpm	Bhp	Rpm	Bhp	Rpm	Bhp	Rpm	Bhp	Rpm	Bhp	Rpm	Bhp	Rpm	Bhp	Rpm	Bhp	Rpm	Bhp
8,000	870	6.81	902	7.26	933	7.73	964	8.20	993	8.67	1022	9.16	1050	9.65	1077	10.14	1104	10.64	1129	11.15
9,000	889	7.85	920	8.31	950	8.79	979	9.27	1008	9.75	1036	10.25	1064	10.75	1090	11.26	1117	11.77	1142	12.29
10,000	912	9.05	941	9.53	970	10.02	998	10.51	1026	11.00	1053	11.51	1080	12.02	1106	12.54	1131	13.06	1157	13.59
11,000	938	10.43	966	10.92	993	11.42	1020	11.93	1047	12.44	1073	12.95	1099	13.47	1124	14.00	1149	14.53	1173	15.07
12,000	967	11.98	993	12.49	1020	13.01	1046	13.53	1071	14.05	1096	14.58	1121	15.11	1145	15.65	1169	16.19	1192	16.74
13,000	998	13.72	1023	14.25	1049	14.78	1073	15.32	1098	15.86	1121	16.40	1145	16.95	1168	17.50	1191	18.06	1214	18.62
14,000	1031	15.64	1055	16.19	1079	16.75	1103	17.30	1126	17.86	1149	18.42	1172	18.98	1195	19.55	1217	20.12	1239	20.69
15,000	1066	17.76	1089	18.33	1112	18.90	1135	19.48	1157	20.06	1179	20.63	1201	21.21	1223	21.80	1244	22.38	1265	22.97
16,000	1102	20.08	1124	20.67	1147	21.26	1168	21.86	1190	22.46	1211	23.06	1232	23.66	1253	24.26	1274	24.86	1294	25.46
17,000	1140	22.61	1161	23.22	1182	23.84	1203	24.45	1224	25.07	1245	25.69	1265	26.31	1285	26.93	—	—	—	—
18,000	1178	25.36	1199	25.99	1219	26.63	1240	27.26	1260	27.90	1279	28.54	1299	29.18	—	—	—	—	—	—
19,000	1218	28.34	1238	28.99	—	—	—	—	—	—	—	—	—	—	—	—	—	—	—	—
20,000	—	—	—	—	—	—	—	—	—	—	—	—	—	—	—	—	—	—	—	—

LEGEND  
**Bhp** — Brake Horsepower  
**edb** — Entering Dry Bulb  
**ewb** — Entering Wet Bulb

2. Conversion — Bhp to watts:

$$\text{Watts} = \frac{\text{Bhp} \times 746}{\text{Motor efficiency}}$$

NOTES:

1. Fan performance is based on wet coils, economizer, roof curb, cabinet losses, and clean 2-in. filters.

3. Variable air volume units will operate down to 70 cfm/ton. Performance at 70 cfm/ton is limited to unloaded operation and may be additionally limited by edb and ewb conditions.

**Table 17 — Fan Performance — 50AJ,AK041 Units**

AIRFLOW (Cfm)	AVAILABLE EXTERNAL STATIC PRESSURE (in. wg)									
	0.2		0.4		0.6		0.8		1.0	
	Rpm	Bhp	Rpm	Bhp	Rpm	Bhp	Rpm	Bhp	Rpm	Bhp
8,000	475	2.69	523	3.08	569	3.47	612	3.86	653	4.26
9,000	521	3.53	565	3.94	606	4.36	646	4.78	684	5.20
10,000	568	4.52	608	4.96	646	5.40	683	5.84	719	6.29
11,000	615	5.68	652	6.14	687	6.60	722	7.07	755	7.55
12,000	663	7.01	697	7.49	730	7.98	762	8.47	794	8.97
13,000	712	8.53	743	9.03	774	9.54	804	10.05	834	10.57
14,000	760	10.24	790	10.76	819	11.29	847	11.82	875	12.36
15,000	809	12.15	837	12.69	864	13.24	891	13.79	917	14.35
16,000	859	14.27	885	14.83	910	15.40	936	15.97	960	16.55
17,000	908	16.61	933	17.19	957	17.77	981	18.36	1004	18.96
18,000	958	19.18	981	19.77	1004	20.37	1027	20.98	1049	21.60
19,000	1007	21.98	1030	22.59	1052	23.21	1073	23.84	1095	24.47
20,000	1057	25.02	1079	25.65	1099	26.29	1120	26.93	1140	27.58

AIRFLOW (Cfm)	AVAILABLE EXTERNAL STATIC PRESSURE (in. wg)									
	1.2		1.4		1.6		1.8		2.0	
	Rpm	Bhp	Rpm	Bhp	Rpm	Bhp	Rpm	Bhp	Rpm	Bhp
8,000	692	4.66	730	5.07	767	5.49	802	5.92	836	6.36
9,000	721	5.63	757	6.06	791	6.49	825	6.94	857	7.39
10,000	753	6.74	787	7.20	819	7.65	851	8.11	882	8.58
11,000	788	8.02	819	8.50	850	8.97	880	9.46	909	9.94
12,000	824	9.47	854	9.96	883	10.47	912	10.97	939	11.48
13,000	862	11.09	891	11.61	918	12.13	945	12.66	972	13.19
14,000	902	12.90	929	13.45	955	13.99	981	14.54	1006	15.09
15,000	943	14.91	968	15.48	993	16.04	1018	16.62	1042	17.18
16,000	985	17.13	1009	17.71	1033	18.30	1056	18.89	1079	19.48
17,000	1028	19.56	1051	20.16	1073	20.77	1096	21.38	1118	21.99
18,000	1071	22.22	1093	22.84	1115	23.46	1136	24.09	1157	24.72
19,000	1116	25.10	1137	25.74	1157	26.39	1178	27.04	1198	27.68
20,000	1161	28.23	1181	28.89	—	—	—	—	—	—

AIRFLOW (Cfm)	AVAILABLE EXTERNAL STATIC PRESSURE (in. wg)									
	2.2		2.4		2.6		2.8		3.0	
	Rpm	Bhp	Rpm	Bhp	Rpm	Bhp	Rpm	Bhp	Rpm	Bhp
8,000	870	6.81	902	7.26	933	7.73	964	8.20	993	8.67
9,000	889	7.85	920	8.31	950	8.79	979	9.27	1008	9.75
10,000	912	9.05	941	9.53	970	10.02	998	10.51	1026	11.00
11,000	938	10.43	966	10.92	993	11.42	1020	11.93	1047	12.44
12,000	967	11.98	993	12.49	1020	13.01	1046	13.53	1071	14.05
13,000	998	13.72	1023	14.25	1049	14.78	1073	15.32	1098	15.86
14,000	1031	15.64	1055	16.19	1079	16.75	1103	17.30	1126	17.86
15,000	1066	17.76	1089	18.33	1112	18.90	1135	19.48	1157	20.06
16,000	1102	20.08	1124	20.67	1147	21.26	1168	21.86	1190	22.46
17,000	1140	22.61	1161	23.22	1182	23.84	1203	24.45	1224	25.07
18,000	1178	25.36	1199	25.99	1219	26.63	1240	27.26	1260	27.90
19,000	1218	28.34	1238	28.99	—	—	—	—	—	—
20,000	—	—	—	—	—	—	—	—	—	—

AIRFLOW (Cfm)	AVAILABLE EXTERNAL STATIC PRESSURE (in. wg)									
	3.2		3.4		3.6		3.8		4.0	
	Rpm	Bhp	Rpm	Bhp	Rpm	Bhp	Rpm	Bhp	Rpm	Bhp
8,000	1022	9.16	1050	9.65	1077	10.14	1104	10.64	1129	11.15
9,000	1036	10.25	1064	10.75	1090	11.26	1117	11.77	1142	12.29
10,000	1053	11.51	1080	12.02	1106	12.54	1131	13.06	1157	13.59
11,000	1073	12.95	1099	13.47	1124	14.00	1149	14.53	1173	15.07
12,000	1096	14.58	1121	15.11	1145	15.65	1169	16.19	1192	16.74
13,000	1121	16.40	1145	16.95	1168	17.50	1191	18.06	1214	18.62
14,000	1149	18.42	1172	18.98	1195	19.55	1217	20.12	1239	20.69
15,000	1179	20.63	1201	21.21	1223	21.80	1244	22.38	1265	22.97
16,000	1211	23.06	1232	23.66	1253	24.26	1274	24.86	1294	25.46
17,000	1245	25.69	1265	26.31	1285	26.93	—	—	—	—
18,000	1279	28.54	1299	29.18	—	—	—	—	—	—
19,000	—	—	—	—	—	—	—	—	—	—
20,000	—	—	—	—	—	—	—	—	—	—

**Table 18 — Fan Performance — 50AJ,AK,A2,A3050 Units**

AIRFLOW (Cfm)	AVAILABLE EXTERNAL STATIC PRESSURE (in. wg)																			
	0.2		0.4		0.6		0.8		1.0		1.2		1.4		1.6		1.8		2.0	
	Rpm	Bhp	Rpm	Bhp	Rpm	Bhp	Rpm	Bhp	Rpm	Bhp	Rpm	Bhp	Rpm	Bhp	Rpm	Bhp	Rpm	Bhp	Rpm	Bhp
8,000	485	2.76	532	3.15	577	3.54	620	3.94	661	4.34	700	4.74	737	5.16	774	5.58	809	6.01	843	6.45
9,000	530	3.62	574	4.03	615	4.45	655	4.87	692	5.29	729	5.72	764	6.15	798	6.59	832	7.03	864	7.49
10,000	577	4.62	617	5.06	655	5.50	692	5.95	727	6.40	761	6.85	794	7.30	827	7.76	858	8.22	889	8.69
11,000	625	5.80	661	6.26	697	6.73	731	7.20	764	7.67	796	8.14	827	8.62	858	9.10	888	9.58	917	10.07
12,000	673	7.15	707	7.63	740	8.12	772	8.62	803	9.11	833	9.61	863	10.11	891	10.61	920	11.12	947	11.62
13,000	722	8.69	753	9.19	784	9.70	814	10.22	843	10.74	872	11.26	900	11.78	927	12.31	954	12.83	980	13.36
14,000	771	10.43	800	10.95	829	11.48	857	12.01	885	12.55	912	13.10	938	13.64	964	14.19	990	14.74	1015	15.29
15,000	821	12.37	848	12.91	875	13.46	901	14.01	928	14.57	953	15.14	978	15.70	1003	16.27	1028	16.84	1052	17.41
16,000	870	14.52	896	15.08	922	15.65	947	16.22	971	16.80	996	17.39	1020	17.97	1043	18.56	1066	19.15	1089	19.75
17,000	920	16.89	945	17.48	969	18.06	993	18.65	1016	19.25	1039	19.86	1062	20.46	1084	21.07	1107	21.68	1129	22.30
18,000	971	19.50	994	20.10	1017	20.71	1039	21.32	1061	21.93	1083	22.55	1105	23.18	1126	23.80	1148	24.44	1169	25.07
19,000	1021	22.35	1043	22.96	1065	23.59	1086	24.21	1107	24.85	1128	25.49	1149	26.13	1170	26.78	1190	27.42	1210	28.08
20,000	1071	25.43	1092	26.07	1113	26.71	1133	27.36	1154	28.01	1174	28.66	1194	29.33	1213	29.99	1233	30.65	1252	31.33

AIRFLOW (Cfm)	AVAILABLE EXTERNAL STATIC PRESSURE (in. wg)																			
	2.2		2.4		2.6		2.8		3.0		3.2		3.4		3.6		3.8		4.0	
	Rpm	Bhp	Rpm	Bhp	Rpm	Bhp	Rpm	Bhp	Rpm	Bhp	Rpm	Bhp	Rpm	Bhp	Rpm	Bhp	Rpm	Bhp	Rpm	Bhp
8,000	876	6.90	908	7.35	939	7.82	970	8.29	999	8.77	1027	9.25	1055	9.74	1082	10.24	1109	10.74	1134	11.25
9,000	896	7.95	926	8.41	956	8.89	986	9.37	1014	9.86	1042	10.36	1069	10.86	1096	11.37	1122	11.88	1148	12.40
10,000	919	9.17	948	9.64	977	10.13	1005	10.62	1032	11.12	1059	11.63	1086	12.14	1112	12.66	1137	13.18	1162	13.71
11,000	945	10.56	973	11.05	1001	11.55	1027	12.06	1054	12.57	1080	13.09	1105	13.61	1130	14.14	1155	14.67	1179	15.21
12,000	975	12.13	1001	12.64	1027	13.16	1053	13.68	1078	14.21	1103	14.74	1128	15.27	1152	15.81	1176	16.35	1199	16.90
13,000	1006	13.89	1032	14.42	1057	14.96	1081	15.49	1105	16.03	1129	16.58	1153	17.12	1176	17.68	1199	18.23	1221	18.80
14,000	1040	15.84	1064	16.39	1088	16.94	1112	17.50	1135	18.06	1158	18.62	1180	19.18	1203	19.75	1225	20.32	1246	20.90
15,000	1075	17.99	1098	18.56	1121	19.13	1144	19.71	1166	20.29	1188	20.86	1210	21.45	1231	22.03	1253	22.62	1274	23.21
16,000	1112	20.34	1134	20.93	1156	21.53	1178	22.12	1199	22.72	1221	23.32	1241	23.92	1262	24.52	1283	25.13	—	—
17,000	1150	22.91	1172	23.52	1193	24.14	1214	24.76	1234	25.37	1255	25.99	1275	26.61	1295	27.23	—	—	—	—
18,000	1190	25.70	1210	26.34	1230	26.97	1250	27.61	1270	28.25	1290	28.89	—	—	—	—	—	—	—	—
19,000	1230	28.73	1250	29.38	1269	30.04	1289	30.70	—	—	—	—	—	—	—	—	—	—	—	—
20,000	1271	31.99	1290	32.67	—	—	—	—	—	—	—	—	—	—	—	—	—	—	—	—

**Table 19 — Fan Performance — 50AJ,AK051 Units**

AIRFLOW (Cfm)	AVAILABLE EXTERNAL STATIC PRESSURE (in. wg)									
	0.2		0.4		0.6		0.8		1.0	
	Rpm	Bhp	Rpm	Bhp	Rpm	Bhp	Rpm	Bhp	Rpm	Bhp
10,000	397	2.69	461	3.31	516	3.96	564	4.63	608	5.33
12,000	450	4.03	509	4.71	560	5.41	605	6.12	647	6.86
13,000	477	4.83	533	5.55	582	6.27	627	7.01	668	7.77
14,000	505	5.74	558	6.49	606	7.24	649	8.01	689	8.79
15,000	533	6.75	584	7.53	630	8.32	672	9.11	711	9.91
16,000	561	7.88	610	8.68	655	9.50	696	10.32	734	11.14
17,000	590	9.12	637	9.95	680	10.79	720	11.64	757	12.49
18,000	619	10.48	664	11.33	706	12.20	744	13.07	781	13.96
19,000	648	11.96	692	12.84	732	13.74	769	14.64	805	15.54
20,000	678	13.57	719	14.47	758	15.40	795	16.32	829	17.25
21,000	707	15.30	748	16.24	785	17.19	821	18.14	854	19.09
22,000	737	17.18	776	18.14	812	19.11	847	20.09	879	21.07
23,000	767	19.20	804	20.18	840	21.17	873	22.17	905	23.18
24,000	797	21.35	833	22.36	867	23.38	900	24.40	931	25.43
25,000	827	23.66	862	24.68	895	25.72	927	26.78	957	27.83

AIRFLOW (Cfm)	AVAILABLE EXTERNAL STATIC PRESSURE (in. wg)									
	1.2		1.4		1.6		1.8		2.0	
	Rpm	Bhp	Rpm	Bhp	Rpm	Bhp	Rpm	Bhp	Rpm	Bhp
10,000	649	6.06	686	6.82	722	7.60	755	8.40	787	9.23
12,000	686	7.62	723	8.40	757	9.21	790	10.04	821	10.89
13,000	706	8.55	742	9.35	776	10.17	808	11.01	839	11.87
14,000	727	9.59	762	10.40	795	11.24	827	12.09	857	12.96
15,000	748	10.73	782	11.56	815	12.41	846	13.28	876	14.17
16,000	770	11.98	803	12.84	836	13.71	866	14.59	896	15.49
17,000	792	13.35	825	14.23	857	15.12	887	16.02	916	16.94
18,000	815	14.84	847	15.74	878	16.65	908	17.57	937	18.50
19,000	838	16.45	870	17.37	900	18.30	930	19.24	958	20.19
20,000	862	18.19	893	19.13	923	20.08	952	21.04	979	22.01
21,000	886	20.05	917	21.02	946	22.00	974	22.98	1001	23.97
22,000	911	22.06	940	23.05	969	24.04	997	25.05	1024	26.06
23,000	935	24.19	965	25.21	993	26.23	1020	27.25	1046	28.28
24,000	961	26.47	989	27.51	1017	28.55	1044	29.60	1070	30.65
25,000	986	28.89	1014	29.95	1041	31.02	1068	32.09	1093	33.17

AIRFLOW (Cfm)	AVAILABLE EXTERNAL STATIC PRESSURE (in. wg)									
	2.2		2.4		2.6		2.8		3.0	
	Rpm	Bhp	Rpm	Bhp	Rpm	Bhp	Rpm	Bhp	Rpm	Bhp
10,000	818	10.06	847	10.92	875	11.80	902	12.68	929	13.59
12,000	851	11.75	880	12.63	907	13.53	934	14.45	960	15.38
13,000	868	12.75	897	13.64	924	14.55	951	15.48	976	16.42
14,000	886	13.85	915	14.76	942	15.68	968	16.62	993	17.57
15,000	905	15.07	933	15.99	960	16.92	986	17.87	1011	18.83
16,000	924	16.41	952	17.34	978	18.28	1004	19.25	1029	20.22
17,000	944	17.86	971	18.81	997	19.77	1023	20.74	1047	21.73
18,000	964	19.45	991	20.41	1017	21.38	1042	22.36	1066	23.36
19,000	985	21.15	1011	22.13	1037	23.12	1061	24.11	1085	25.13
20,000	1006	22.99	1032	23.98	1057	24.99	1081	26.00	1105	27.03
21,000	1028	24.97	1053	25.97	1078	26.99	1102	28.02	1126	29.06
22,000	1050	27.08	1075	28.10	1099	29.14	1123	30.18	1146	31.24
23,000	1072	29.32	1097	30.37	1121	31.42	1144	32.48	1167	33.55
24,000	1095	31.71	1119	32.78	1143	33.85	1166	34.93	1189	36.02
25,000	1118	34.25	1142	35.33	1165	36.42	1188	37.52	—	—

AIRFLOW (Cfm)	AVAILABLE EXTERNAL STATIC PRESSURE (in. wg)									
	3.2		3.4		3.6		3.8		4.0	
	Rpm	Bhp	Rpm	Bhp	Rpm	Bhp	Rpm	Bhp	Rpm	Bhp
10,000	954	14.50	979	15.42	1003	16.36	1027	17.30	1050	18.26
12,000	985	16.32	1010	17.28	1033	18.24	1057	19.22	1079	20.22
13,000	1001	17.38	1026	18.35	1049	19.32	1072	20.32	1095	21.32
14,000	1018	18.54	1042	19.52	1066	20.51	1088	21.52	1111	22.53
15,000	1035	19.81	1059	20.81	1082	21.81	1105	22.82	1127	23.85
16,000	1053	21.21	1077	22.21	1100	23.22	1122	24.25	1144	25.29
17,000	1071	22.73	1095	23.74	1117	24.76	1140	25.80	1161	26.85
18,000	1090	24.37	1113	25.40	1136	26.43	1158	27.48	1179	28.54
19,000	1109	26.15	1132	27.19	1154	28.24	1176	29.29	1197	30.36
20,000	1128	28.06	1151	29.11	1173	30.17	1195	31.24	—	—
21,000	1148	30.11	1171	31.17	1193	32.25	—	—	—	—
22,000	1169	32.30	1191	33.38	—	—	—	—	—	—
23,000	1190	34.64	—	—	—	—	—	—	—	—
24,000	—	—	—	—	—	—	—	—	—	—
25,000	—	—	—	—	—	—	—	—	—	—

**Table 20 — Fan Performance — 50AJ,AK,A2,A3060 Units**

AIRFLOW (Cfm)	AVAILABLE EXTERNAL STATIC PRESSURE (in. wg)																			
	0.2		0.4		0.6		0.8		1.0		1.2		1.4		1.6		1.8		2.0	
	Rpm	Bhp	Rpm	Bhp	Rpm	Bhp	Rpm	Bhp	Rpm	Bhp	Rpm	Bhp	Rpm	Bhp	Rpm	Bhp	Rpm	Bhp	Rpm	Bhp
12,000	450	4.02	509	4.71	560	5.41	605	6.12	647	6.86	686	7.62	723	8.40	757	9.21	790	10.04	821	10.89
14,000	505	5.74	558	6.49	606	7.24	649	8.01	689	8.79	727	9.59	762	10.40	795	11.24	827	12.09	857	12.96
15,000	533	6.75	584	7.53	630	8.32	672	9.11	711	9.91	748	10.73	782	11.56	815	12.41	846	13.28	876	14.17
16,000	561	7.88	610	8.68	655	9.50	696	10.32	734	11.14	770	11.98	803	12.84	836	13.71	866	14.59	896	15.49
17,000	590	9.12	637	9.95	680	10.79	720	11.64	757	12.49	792	13.35	825	14.23	857	15.12	887	16.02	916	16.94
18,000	619	10.48	664	11.33	706	12.20	744	13.07	781	13.96	815	14.84	847	15.74	878	16.65	908	17.57	937	18.50
19,000	648	11.96	692	12.84	732	13.74	769	14.64	805	15.54	838	16.45	870	17.37	900	18.30	930	19.24	958	20.19
20,000	678	13.57	719	14.47	758	15.40	795	16.32	829	17.25	862	18.19	893	19.13	923	20.08	952	21.04	979	22.01
21,000	707	15.30	748	16.24	785	17.19	821	18.14	854	19.09	886	20.05	917	21.02	946	22.00	974	22.98	1001	23.97
22,000	737	17.18	776	18.14	812	19.11	847	20.09	879	21.07	911	22.06	940	23.05	969	24.04	997	25.05	1024	26.06
23,000	767	19.20	804	20.18	840	21.17	873	22.19	905	23.18	935	24.19	965	25.21	993	26.23	1020	27.25	1046	28.28
24,000	797	21.35	833	22.36	867	23.38	900	24.40	931	25.43	961	26.47	989	27.51	1017	28.55	1044	29.60	1070	30.65
25,000	827	23.66	862	24.68	895	25.72	927	26.78	957	27.83	986	28.89	1014	29.95	1041	31.02	1068	32.09	1093	33.17
26,000	857	26.11	891	27.16	923	28.23	954	29.30	984	30.38	1012	31.46	1040	32.55	1066	33.64	1092	34.73	1117	35.83
27,000	888	28.72	920	29.79	952	30.88	982	31.97	1011	33.08	1038	34.19	1065	35.29	1091	36.40	1117	37.52	1141	38.64

AIRFLOW (Cfm)	AVAILABLE EXTERNAL STATIC PRESSURE (in. wg)																			
	2.2		2.4		2.6		2.8		3.0		3.2		3.4		3.6		3.8		4.0	
	Rpm	Bhp	Rpm	Bhp	Rpm	Bhp	Rpm	Bhp	Rpm	Bhp	Rpm	Bhp	Rpm	Bhp	Rpm	Bhp	Rpm	Bhp	Rpm	Bhp
12,000	851	11.75	880	12.63	907	13.53	934	14.45	960	15.38	985	16.32	1010	17.28	1033	18.24	1057	19.22	1079	20.22
14,000	886	13.85	915	14.76	942	15.68	968	16.62	993	17.57	1018	18.54	1042	19.52	1066	20.51	1088	21.52	1111	22.53
15,000	905	15.07	933	15.99	960	16.92	986	17.87	1011	18.83	1035	19.81	1059	20.81	1082	21.81	1105	22.82	1127	23.85
16,000	924	16.41	952	17.34	978	18.28	1004	19.25	1029	20.22	1053	21.21	1077	22.21	1100	23.22	1122	24.25	1144	25.29
17,000	944	17.86	971	18.81	997	19.77	1023	20.74	1047	21.73	1071	22.73	1095	23.74	1117	24.76	1140	25.80	1161	26.85
18,000	964	19.45	991	20.41	1017	21.38	1042	22.36	1066	23.36	1090	24.37	1113	25.40	1136	26.43	1158	27.48	1179	28.54
19,000	985	21.15	1011	22.13	1037	23.12	1061	24.11	1085	25.13	1109	26.15	1132	27.19	1154	28.24	1176	29.29	1197	30.36
20,000	1006																			

**Table 21 — Fan Performance — 48AW,AY020,025 and 48A4,A5020 Units**

AIRFLOW (CFM)	AVAILABLE EXTERNAL STATIC PRESSURE (in. wg)																			
	0.2		0.4		0.6		0.8		1.0		1.2		1.4		1.6		1.8		2.0	
	Rpm	Bhp	Rpm	Bhp	Rpm	Bhp	Rpm	Bhp	Rpm	Bhp	Rpm	Bhp	Rpm	Bhp	Rpm	Bhp	Rpm	Bhp	Rpm	Bhp
4,000	339	0.71	414	0.97	478	1.25	534	1.54	585	1.84	631	2.14	674	2.44	714	2.75	751	3.06	787	3.37
5,000	384	1.10	452	1.37	510	1.66	563	1.96	611	2.28	656	2.60	698	2.93	738	3.27	775	3.60	811	3.94
6,000	433	1.61	494	1.89	548	2.19	597	2.51	643	2.84	686	3.18	726	3.52	764	3.88	800	4.23	835	4.60
7,000	484	2.27	540	2.56	590	2.87	636	3.19	679	3.53	719	3.88	757	4.24	794	4.61	829	4.98	863	5.36
7,500	511	2.66	563	2.95	612	3.26	656	3.59	698	3.94	737	4.29	775	4.66	810	5.03	845	5.41	877	5.79
8,000	538	3.09	588	3.38	634	3.70	678	4.03	718	4.38	756	4.74	793	5.11	827	5.49	861	5.87	893	6.26
9,000	593	4.07	639	4.37	682	4.69	722	5.03	760	5.39	796	5.76	831	6.13	864	6.52	896	6.91	927	7.32
10,000	649	5.23	691	5.54	731	5.87	769	6.21	805	6.58	839	6.95	872	7.34	904	7.73	934	8.13	964	8.54
11,000	706	6.58	744	6.89	782	7.23	817	7.58	851	7.95	884	8.33	915	8.72	945	9.12	975	9.53	1003	9.95
12,000	763	8.12	799	8.45	834	8.79	867	9.14	899	9.52	930	9.90	960	10.30	989	10.71	1017	11.12	1045	11.54
12,500	792	8.97	827	9.30	860	9.64	893	10.00	924	10.38	954	10.77	983	11.16	1012	11.57	1039	11.99	1066	12.42
13,000	821	9.87	855	10.20	887	10.55	918	10.91	949	11.29	978	11.68	1007	12.08	1034	12.49	1062	12.92	1088	13.35

AIRFLOW (CFM)	AVAILABLE EXTERNAL STATIC PRESSURE (in. wg)																			
	2.2		2.4		2.6		2.8		3.0		3.2		3.4		3.6		3.8		4.0	
	Rpm	Bhp	Rpm	Bhp	Rpm	Bhp	Rpm	Bhp	Rpm	Bhp	Rpm	Bhp	Rpm	Bhp	Rpm	Bhp	Rpm	Bhp	Rpm	Bhp
4,000	820	3.68	852	3.99	883	4.30	912	4.62	940	4.93	967	5.25	993	5.57	1019	5.89	1043	6.21	1067	6.53
5,000	844	4.28	877	4.63	907	4.97	937	5.31	966	5.66	993	6.01	1020	6.35	1046	6.70	1071	7.05	1095	7.40
6,000	869	4.96	901	5.33	931	5.70	961	6.07	990	6.44	1017	6.81	1044	7.19	1070	7.57	1096	7.94	1121	8.32
7,000	895	5.74	926	6.13	956	6.52	986	6.91	1014	7.30	1042	7.70	1068	8.10	1094	8.50	1120	8.90	1145	9.30
7,500	909	6.18	940	6.57	970	6.97	999	7.37	1027	7.78	1054	8.18	1081	8.59	1107	9.00	1132	9.41	1157	9.82
8,000	925	6.66	955	7.06	984	7.46	1013	7.87	1040	8.28	1067	8.69	1094	9.11	1119	9.53	1144	9.95	1169	10.37
9,000	957	7.72	986	8.13	1015	8.55	1042	8.97	1069	9.39	1096	9.82	1121	10.25	1146	10.69	1171	11.12	1195	11.56
10,000	993	8.96	1021	9.38	1048	9.80	1075	10.23	1101	10.67	1126	11.11	1151	11.55	1176	12.00	1200	12.45	—	—
11,000	1031	10.37	1058	10.80	1084	11.23	1110	11.67	1135	12.12	1160	12.56	1184	13.02	—	—	—	—	—	—
12,000	1071	11.97	1097	12.41	1123	12.85	1148	13.30	1172	13.75	1196	14.21	—	—	—	—	—	—	—	—
12,500	1092	12.85	1118	13.29	1143	13.74	1167	14.19	1191	14.64	—	—	—	—	—	—	—	—	—	—
13,000	1113	13.78	1139	14.22	1163	14.67	—	—	—	—	—	—	—	—	—	—	—	—	—	—

**Table 22 — Fan Performance — 48AW,AY027,030 and 48A4,A5025-030 Units**

AIRFLOW (CFM)	AVAILABLE EXTERNAL STATIC PRESSURE (in. wg)																			
	0.2		0.4		0.6		0.8		1.0		1.2		1.4		1.6		1.8		2.0	
	Rpm	Bhp	Rpm	Bhp	Rpm	Bhp	Rpm	Bhp	Rpm	Bhp	Rpm	Bhp	Rpm	Bhp	Rpm	Bhp	Rpm	Bhp	Rpm	Bhp
4,000	342	0.72	417	0.98	480	1.26	536	1.55	587	1.85	633	2.15	676	2.45	715	2.76	753	3.07	788	3.38
5,000	389	1.11	456	1.38	514	1.68	566	1.98	614	2.30	659	2.62	701	2.95	740	3.29	777	3.62	813	3.96
6,000	439	1.64	499	1.92	553	2.22	602	2.54	647	2.87	689	3.21	730	3.56	768	3.91	804	4.27	838	4.63
7,000	492	2.31	546	2.60	596	2.91	641	3.24	684	3.58	724	3.93	762	4.29	798	4.66	833	5.03	867	5.41
8,000	546	3.14	596	3.43	642	3.75	684	4.09	724	4.44	762	4.80	798	5.17	833	5.55	866	5.93	898	6.32
9,000	602	4.13	647	4.43	690	4.76	730	5.10	768	5.46	803	5.83	838	6.21	871	6.60	903	7.00	933	7.40
10,000	659	5.31	701	5.62	740	5.95	777	6.30	813	6.67	847	7.04	880	7.43	911	7.83	942	8.23	971	8.64
11,000	717	6.67	755	6.99	792	7.33	827	7.68	860	8.06	893	8.44	924	8.83	954	9.24	983	9.65	1011	10.07
12,000	775	8.23	811	8.56	845	8.90	878	9.27	909	9.64	940	10.03	970	10.43	999	10.84	1026	11.26	1054	11.69
13,000	834	9.99	867	10.33	899	10.68	930	11.05	960	11.44	989	11.83	1017	12.24	1045	12.65	1072	13.08	1098	13.51
14,000	893	11.97	924	12.32	954	12.68	983	13.06	1012	13.44	1039	13.85	1066	14.26	1093	14.68	1118	15.11	1143	15.54
15,000	953	14.17	982	14.53	1010	14.90	1037	15.28	1064	15.68	1091	16.08	1116	16.50	1142	16.93	1166	17.36	1190	17.80

AIRFLOW (CFM)	AVAILABLE EXTERNAL STATIC PRESSURE (in. wg)																			
	2.2		2.4		2.6		2.8		3.0		3.2		3.4		3.6		3.8		4.0	
	Rpm	Bhp	Rpm	Bhp	Rpm	Bhp	Rpm	Bhp	Rpm	Bhp	Rpm	Bhp	Rpm	Bhp	Rpm	Bhp	Rpm	Bhp	Rpm	Bhp
4,000	821	3.69	853	4.00	884	4.31	913	4.63	941	4.95	968	5.26	994	5.58	1020	5.90	1044	6.22	1068	6.55
5,000	846	4.31	879	4.65	909	4.99	939	5.34	968	5.68	995	6.03	1022	6.38	1048	6.73	1073	7.08	1097	7.43
6,000	872	5.00	903	5.36	934	5.73	964	6.10	992	6.48	1020	6.85	1047	7.22	1073	7.60	1098	7.98	1123	8.36
7,000	899	5.79	930	6.18	960	6.57	989	6.96	1018	7.36	1045	7.75	1072	8.15	1098	8.55	1123	8.95	1148	9.35
8,000	930	6.72	960	7.12	989	7.53	1017	7.94	1045	8.35	1072	8.76	1098	9.18	1124	9.60	1148	10.02	1173	10.44
9,000	963	7.80	992	8.22	1020	8.63	1048	9.06	1075	9.48	1101	9.91	1126	10.34	1151	10.78	1176	11.21	1200	11.65
10,000	1000	9.06	1028	9.48	1055	9.91	1081	10.34	1107	10.77	1133	11.22	1157	11.66	1182	12.11	—	—	—	—
11,000	1039	10.49	1066	10.92	1092	11.36	1117	11.80	1142	12.24	1167	12.69	1191	13.15	—	—	—	—	—	—
12,000	1080	12.12	1106	12.56	1131	13.00	1156	13.45	1180	13.90	—	—	—	—	—	—	—	—	—	—
13,000	1123	13.95	1148	14.39	1172	14.84	1196	15.30	—	—	—	—	—	—	—	—	—	—	—	—
14,000	1168	15.99	1192	16.44	—	—	—	—	—	—	—	—	—	—	—	—	—	—	—	—
15,000	—	—	—	—	—	—	—	—	—	—	—	—	—	—	—	—	—	—	—	—

**LEGEND**

**Bhp** — Brake Horsepower  
**edb** — Entering Dry Bulb  
**ewb** — Entering Wet Bulb

**NOTES:**

1. Fan performance is based on wet coils, economizer, roof curb, cabinet losses, and clean 2-in. filters.

2. Conversion — Bhp to watts:

$$\text{Watts} = \frac{\text{Bhp} \times 746}{\text{Motor efficiency}}$$

3. Variable air volume units will operate down to 70 cfm/ton. Performance at 70 cfm/ton is limited to unloaded operation and may be additionally limited by edb and ewb conditions.

**Table 23 — Fan Performance — 48AW,AY,A4,A5035 Units**

AIRFLOW (Cfm)	AVAILABLE EXTERNAL STATIC PRESSURE (in. wg)																			
	0.2		0.4		0.6		0.8		1.0		1.2		1.4		1.6		1.8		2.0	
	Rpm	Bhp	Rpm	Bhp	Rpm	Bhp	Rpm	Bhp	Rpm	Bhp	Rpm	Bhp	Rpm	Bhp	Rpm	Bhp	Rpm	Bhp	Rpm	Bhp
7,000	553	2.59	602	2.92	648	3.26	691	3.61	732	3.95	770	4.29	807	4.63	842	4.96	875	5.29	907	5.62
8,000	612	3.45	656	3.81	698	4.17	738	4.53	776	4.90	812	5.27	847	5.63	881	6.00	913	6.36	944	6.72
9,000	672	4.47	712	4.86	750	5.24	787	5.62	823	6.01	857	6.39	890	6.78	922	7.17	953	7.56	983	7.95
10,000	733	5.67	769	6.08	805	6.48	839	6.88	872	7.28	904	7.69	935	8.10	966	8.51	995	8.92	1024	9.33
10,500	763	6.33	798	6.75	832	7.17	865	7.58	897	7.99	929	8.40	959	8.82	989	9.24	1017	9.66	1046	10.08
11,000	794	7.04	828	7.47	861	7.90	892	8.32	923	8.74	954	9.16	983	9.59	1012	10.01	1040	10.44	1067	10.87
12,000	855	8.60	887	9.06	918	9.51	948	9.95	977	10.39	1005	10.83	1033	11.27	1060	11.71	1087	12.16	1113	12.60
13,000	917	10.36	947	10.84	976	11.31	1004	11.77	1031	12.23	1058	12.69	1084	13.14	1110	13.60	1135	14.06	1160	14.52
14,000	980	12.32	1008	12.82	1035	13.31	1061	13.79	1087	14.27	1112	14.75	1137	15.22	1161	15.70	1185	16.17	1209	16.65
15,000	1042	14.49	1069	15.01	1094	15.52	1119	16.03	1143	16.53	1167	17.02	1191	17.51	1214	18.01	1237	18.50	1260	18.99
16,000	1105	16.88	1130	17.42	1154	17.96	1178	18.48	1201	19.00	1224	19.51	1246	20.02	1268	20.53	1290	21.04	—	—
17,000	1168	19.49	1191	20.06	1214	20.61	1237	21.16	1259	21.69	1281	22.23	—	—	—	—	—	—	—	—
17,500	1200	20.88	1222	21.46	1245	22.03	1267	22.58	1288	23.13	—	—	—	—	—	—	—	—	—	—

**Table 24 — Fan Performance — 48AW,AY036 Units**

AIRFLOW (Cfm)	AVAILABLE EXTERNAL STATIC PRESSURE (in. wg)																			
	2.2		2.4		2.6		2.8		3.0		3.2		3.4		3.6		3.8		4.0	
	Rpm	Bhp	Rpm	Bhp	Rpm	Bhp	Rpm	Bhp	Rpm	Bhp	Rpm	Bhp	Rpm	Bhp	Rpm	Bhp	Rpm	Bhp	Rpm	Bhp
7,000	937	5.94	967	6.26	995	6.57	1022	6.87	1048	7.18	1073	7.48	1098	7.78	1122	8.07	1145	8.36	1168	8.66
8,000	974	7.08	1003	7.43	1031	7.77	1058	8.12	1084	8.46	1109	8.79	1134	9.13	1158	9.46	1181	9.78	1204	10.11
9,000	1012	8.33	1041	8.72	1068	9.10	1094	9.47	1120	9.85	1145	10.22	1169	10.58	1193	10.95	1216	11.31	1239	11.66
10,000	1052	9.74	1080	10.15	1106	10.55	1132	10.96	1157	11.36	1182	11.76	1206	12.16	1229	12.55	1252	12.95	1275	13.34
10,500	1073	10.50	1100	10.92	1126	11.34	1151	11.75	1176	12.17	1201	12.59	1224	13.00	1248	13.41	1271	13.82	1293	14.22
11,000	1094	11.30	1120	11.73	1146	12.16	1171	12.59	1196	13.02	1220	13.45	1243	13.87	1266	14.30	1289	14.72	—	—
12,000	1138	13.05	1163	13.50	1188	13.95	1212	14.40	1236	14.84	1259	15.30	1282	15.74	—	—	—	—	—	—
13,000	1184	14.99	1208	15.45	1232	15.92	1255	16.39	1278	16.85	—	—	—	—	—	—	—	—	—	—
14,000	1232	17.13	1255	17.61	1278	18.09	—	—	—	—	—	—	—	—	—	—	—	—	—	—
15,000	1282	19.48	—	—	—	—	—	—	—	—	—	—	—	—	—	—	—	—	—	—
16,000	—	—	—	—	—	—	—	—	—	—	—	—	—	—	—	—	—	—	—	—
17,000	—	—	—	—	—	—	—	—	—	—	—	—	—	—	—	—	—	—	—	—
17,500	—	—	—	—	—	—	—	—	—	—	—	—	—	—	—	—	—	—	—	—

AIRFLOW (Cfm)	AVAILABLE EXTERNAL STATIC PRESSURE (in. wg)									
	1.2		1.4		1.6		1.8		2.0	
	Rpm	Bhp	Rpm	Bhp	Rpm	Bhp	Rpm	Bhp	Rpm	Bhp
7,000	709	4.25	749	4.68	788	5.11	825	5.55	860	6.00
8,000	740	5.18	778	5.62	814	6.07	850	6.53	884	7.00
9,000	775	6.28	810	6.74	845	7.21	878	7.69	911	8.17
10,000	813	7.57	846	8.05	879	8.53	910	9.03	941	9.53
11,000	854	9.04	885	9.54	916	10.05	945	10.56	974	11.08
12,000	898	10.72	927	11.24	955	11.77	983	12.30	1011	12.84
13,000	943	12.61	970	13.15	997	13.70	1024	14.25	1050	14.81
14,000	990	14.72	1016	15.29	1041	15.86	1066	16.43	1091	17.01
15,000	1038	17.06	1062	17.65	1086	18.25	1110	18.84	1134	19.44
16,000	1086	19.65	1110	20.26	1133	20.88	1156	21.49	1178	22.11
17,000	1136	22.49	1158	23.12	1180	23.76	1202	24.39	1223	25.03
17,500	1161	24.01	1183	24.65	1205	25.30	1226	25.94	1247	26.59

AIRFLOW (Cfm)	AVAILABLE EXTERNAL STATIC PRESSURE (in. wg)									
	2.2		2.4		2.6		2.8		3.0	
	Rpm	Bhp	Rpm	Bhp	Rpm	Bhp	Rpm	Bhp	Rpm	Bhp
7,000	894	6.46	927	6.92	958	7.38	988	7.85	1017	8.33
8,000	917	7.48	949	7.96	980	8.44	1010	8.93	1039	9.43
9,000	942	8.66	973	9.16	1003	9.66	1033	10.17	1061	10.69
10,000	971	10.03	1001	10.55	1030	11.06	1058	11.59	1086	12.12
11,000	1003	11.60	1031	12.13	1059	12.67	1086	13.21	1112	13.75
12,000	1038	13.38	1065	13.92	1091	14.47	1117	15.03	1142	15.59
13,000	1075	15.37	1101	15.93	1126	16.50	1150	17.07	1175	17.65
14,000	1115	17.59	1139	18.17	1163	18.75	1186	19.34	1210	19.94
15,000	1157	20.04	1180	20.64	1202	21.24	1225	21.85	1247	22.46
16,000	1200	22.73	1222	23.35	1243	23.97	1265	24.60	1286	25.23
17,000	1245	25.67	1266	26.32	1286	26.96	—	—	—	—
17,500	1267	27.24	1288	27.89	—	—	—	—	—	—

AIRFLOW (Cfm)	AVAILABLE EXTERNAL STATIC PRESSURE (in. wg)									
	3.2		3.4		3.6		3.8		4.0	
	Rpm	Bhp	Rpm	Bhp	Rpm	Bhp	Rpm	Bhp	Rpm	Bhp
7,000	1046	8.81	1073	9.29	1099	9.78	1125	10.27	1150	10.76
8,000	1067	9.93	1094	10.44	1121	10.95	1147	11.46	1172	11.98
9,000	1089	11.21	1116	11.73	1142	12.26	1168	12.80	1193	13.33
10,000	1113	12.66	1139	13.20	1165	13.75	1190	14.30	1215	14.86
11,000	1139	14.31	1164	14.86	1189	15.43	1214	15.99	1238	16.56
12,000	1167	16.16	1192	16.73	1216	17.31	1240	17.89	1264	18.48
13,000	1199	18.23	1222	18.82	1246	19.41	1269	20.00	1291	20.61
14,000	1232	20.53	1255	21.14	1277	21.74	1300	22.35	—	—
15,000	1269	23.07	1290	23.69	—	—	—	—	—	—
16,000	—	—	—	—	—	—	—	—	—	—
17,000	—	—	—	—	—	—	—	—	—	—
17,500	—	—	—	—	—	—	—	—	—	—

See legend on page 17.



**Table 25 — Fan Performance — 48AW,AY,A4,A5040 Units**

AIRFLOW (Cfm)	AVAILABLE EXTERNAL STATIC PRESSURE (in. wg)																			
	0.2		0.4		0.6		0.8		1.0		1.2		1.4		1.6		1.8		2.0	
	Rpm	Bhp	Rpm	Bhp	Rpm	Bhp	Rpm	Bhp	Rpm	Bhp	Rpm	Bhp	Rpm	Bhp	Rpm	Bhp	Rpm	Bhp	Rpm	Bhp
8,000	526	3.10	573	3.50	617	3.91	660	4.33	700	4.75	740	5.18	778	5.62	814	6.07	850	6.53	884	7.00
9,000	579	4.08	621	4.51	662	4.95	701	5.39	738	5.83	775	6.28	810	6.74	845	7.21	878	7.69	911	8.17
10,000	633	5.24	671	5.70	709	6.16	744	6.62	779	7.09	813	7.57	846	8.05	879	8.53	910	9.03	941	9.53
11,000	687	6.59	723	7.07	757	7.56	790	8.05	823	8.54	854	9.04	885	9.54	916	10.05	945	10.56	974	11.08
12,000	742	8.15	775	8.65	807	9.17	838	9.68	868	10.20	898	10.72	927	11.24	955	11.77	983	12.30	1011	12.84
13,000	797	9.92	827	10.45	857	10.98	887	11.52	915	12.07	943	12.61	970	13.15	997	13.70	1024	14.25	1050	14.81
14,000	852	11.92	881	12.47	909	13.03	936	13.59	963	14.15	990	14.72	1016	15.29	1041	15.86	1066	16.43	1091	17.01
15,000	908	14.15	935	14.72	961	15.31	987	15.89	1013	16.48	1038	17.06	1062	17.65	1086	18.25	1110	18.84	1134	19.44
16,000	964	16.63	989	17.23	1014	17.83	1039	18.43	1063	19.04	1086	19.65	1110	20.26	1133	20.88	1156	21.49	1178	22.11
17,000	1021	19.37	1044	19.98	1068	20.60	1091	21.23	1114	21.86	1136	22.49	1158	23.12	1180	23.76	1202	24.39	1223	25.03
18,000	1077	22.37	1099	23.01	1122	23.64	1144	24.29	1165	24.94	1187	25.59	1208	26.25	1229	26.90	1250	27.56	1270	28.22
19,000	1133	25.65	1155	26.30	1176	26.96	1197	27.62	1217	28.29	1238	28.96	—	—	—	—	—	—	—	—
20,000	1190	29.21	—	—	—	—	—	—	—	—	—	—	—	—	—	—	—	—	—	—

AIRFLOW (Cfm)	AVAILABLE EXTERNAL STATIC PRESSURE (in. wg)																			
	2.2		2.4		2.6		2.8		3.0		3.2		3.4		3.6		3.8		4.0	
	Rpm	Bhp	Rpm	Bhp	Rpm	Bhp	Rpm	Bhp	Rpm	Bhp	Rpm	Bhp	Rpm	Bhp	Rpm	Bhp	Rpm	Bhp	Rpm	Bhp
8,000	917	7.48	949	7.96	980	8.44	1010	8.94	1039	9.43	1067	9.93	1094	10.44	1121	10.95	1147	11.46	1172	11.98
9,000	942	8.66	973	9.16	1003	9.66	1033	10.17	1061	10.69	1089	11.21	1116	11.73	1142	12.26	1168	12.80	1193	13.33
10,000	971	10.03	1001	10.55	1030	11.06	1058	11.59	1086	12.12	1113	12.66	1139	13.20	1165	13.75	1190	14.30	1215	14.86
11,000	1003	11.60	1031	12.13	1059	12.67	1086	13.21	1112	13.75	1139	14.31	1164	14.86	1189	15.43	1214	15.99	1238	16.56
12,000	1038	13.38	1065	13.92	1091	14.47	1117	15.03	1142	15.59	1167	16.16	1192	16.73	1216	17.31	1240	17.89	1264	18.48
13,000	1075	15.37	1101	15.93	1126	16.50	1150	17.07	1175	17.65	1199	18.23	1222	18.82	1246	19.41	1269	20.00	1291	20.61
14,000	1115	17.59	1139	18.17	1163	18.75	1186	19.34	1210	19.94	1232	20.53	1255	21.14	1277	21.74	1300	22.35	—	—
15,000	1157	20.04	1180	20.64	1202	21.24	1225	21.85	1247	22.46	1269	23.07	1290	23.69	—	—	—	—	—	—
16,000	1200	22.73	1222	23.35	1243	23.97	1265	24.60	1286	25.23	—	—	—	—	—	—	—	—	—	—
17,000	1245	25.67	1266	26.32	1286	26.96	—	—	—	—	—	—	—	—	—	—	—	—	—	—
18,000	1290	28.88	—	—	—	—	—	—	—	—	—	—	—	—	—	—	—	—	—	—
19,000	—	—	—	—	—	—	—	—	—	—	—	—	—	—	—	—	—	—	—	—
20,000	—	—	—	—	—	—	—	—	—	—	—	—	—	—	—	—	—	—	—	—

**Table 26 — Fan Performance — 48AW,AY041 Units**

AIRFLOW (Cfm)	AVAILABLE EXTERNAL STATIC PRESSURE (in. wg)									
	0.2		0.4		0.6		0.8		1.0	
	Rpm	Bhp	Rpm	Bhp	Rpm	Bhp	Rpm	Bhp	Rpm	Bhp
8,000	526	3.10	573	3.50	617	3.91	660	4.33	700	4.75
9,000	579	4.08	621	4.51	662	4.95	701	5.39	738	5.83
10,000	633	5.24	671	5.70	709	6.16	744	6.62	779	7.09
11,000	687	6.59	723	7.07	757	7.56	790	8.05	823	8.54
12,000	742	8.15	775	8.65	807	9.17	838	9.68	868	10.20
13,000	797	9.92	827	10.45	857	10.98	887	11.52	915	12.07
14,000	852	11.92	881	12.47	909	13.03	936	13.59	963	14.15
15,000	908	14.15	935	14.72	961	15.31	987	15.89	1013	16.48
16,000	964	16.63	989	17.23	1014	17.83	1039	18.43	1063	19.04
17,000	1021	19.37	1044	19.98	1068	20.60	1091	21.23	1114	21.86
18,000	1077	22.37	1099	23.01	1122	23.64	1144	24.29	1165	24.94
19,000	1133	25.65	1155	26.30	1176	26.96	1197	27.62	1217	28.29
20,000	1190	29.21	—	—	—	—	—	—	—	—

AIRFLOW (Cfm)	AVAILABLE EXTERNAL STATIC PRESSURE (in. wg)									
	1.2		1.4		1.6		1.8		2.0	
	Rpm	Bhp	Rpm	Bhp	Rpm	Bhp	Rpm	Bhp	Rpm	Bhp
8,000	740	5.18	778	5.62	814	6.07	850	6.53	884	7.00
9,000	775	6.28	810	6.74	845	7.21	878	7.69	911	8.17
10,000	813	7.57	846	8.05	879	8.53	910	9.03	941	9.53
11,000	854	9.04	885	9.54	916	10.05	945	10.56	974	11.08
12,000	898	10.72	927	11.24	955	11.77	983	12.30	1011	12.84
13,000	943	12.61	970	13.15	997	13.70	1024	14.25	1050	14.81
14,000	990	14.72	1016	15.29	1041	15.86	1066	16.43	1091	17.01
15,000	1038	17.06	1062	17.65	1086	18.25	1110	18.84	1134	19.44
16,000	1086	19.65	1110	20.26	1133	20.88	1156	21.49	1178	22.11
17,000	1136	22.49	1158	23.12	1180	23.76	1202	24.39	1223	25.03
18,000	1187	25.59	1208	26.25	1229	26.90	1250	27.56	1270	28.22
19,000	1238	—	—	—	—	—	—	—	—	—
20,000	—	—	—	—	—	—	—	—	—	—

AIRFLOW (Cfm)	AVAILABLE EXTERNAL STATIC PRESSURE (in. wg)									
	2.2		2.4		2.6		2.8		3.0	
	Rpm	Bhp	Rpm	Bhp	Rpm	Bhp	Rpm	Bhp	Rpm	Bhp
8,000	917	7.48	949	7.96	980	8.44	1010	8.94	1039	9.43
9,000	942	8.66	973	9.16	1003	9.66	1033	10.17	1061	10.69
10,000	971	10.03	1001	10.55	1030	11.06	1058	11.59	1086	12.12
11,000	1003	11.60	1031	12.13	1059	12.67	1086	13.21	1112	13.75
12,000	1038	13.38	1065	13.92	1091	14.47	1117	15.03	1142	15.59
13,000	1075	15.37	1101	15.93	1126	16.50	1150	17.07	1175	17.65
14,000	1115	17.59	1139	18.17	1163	18.75	1186	19.34	1210	19.94
15,000	1157	20.04	1180	20.64	1202	21.24	1225	21.85	1247	22.46
16,000	1200	22.73	1222	23.35	1243	23.97	1265	24.60	1286	25.23
17,000	1245	25.67	1266	26.32	1286	26.96	—	—	—	—
18,000	1290	28.88	—	—	—	—	—	—	—	—
19,000	—	—	—	—	—	—	—	—	—	—
20,000	—	—	—	—	—	—	—	—	—	—

AIRFLOW (Cfm)	AVAILABLE EXTERNAL STATIC PRESSURE (in. wg)									
	3.2		3.4		3.6		3.8		4.0	
	Rpm	Bhp	Rpm	Bhp	Rpm	Bhp	Rpm	Bhp	Rpm	Bhp
8,000	1067	9.93	1094	10.44	1121	10.95	1147	11.46	1172	11.98
9,000	1089	11.21	1116	11.73	1142	12.26	1168	12.80	1193	13.33
10,000	1113	12.66	1139	13.20	1165	13.75	1190	14.30	1215	14.86
11,000	1139	14.31	1164	14.86	1189	15.43	1214	15.99	1238	16.56
12,000	1167	16.16	1192	16.73	1216	17.31	1240	17.89	1264	18.48
13,000	1199	18.23	1222	18.82	1246	19.41	1269	20.00	1291	20.61
14,000	1232	20.53	1255	21.14	1277	21.74	1300	22.35	—	—
15,000	1269	23.07	1290	23.69	—	—	—	—	—	—
16,000	—	—	—	—	—	—	—	—	—	—
17,000	—	—	—	—	—	—	—	—	—	—
18,000	—	—	—	—	—	—	—	—	—	—
19,000	—	—	—	—	—	—	—	—	—	—
20,000	—	—	—	—	—	—	—	—	—	—

See legend on page 17.



**Table 29 — Fan Performance — 48AW,AY,A4,A5060 Units**

AIRFLOW (Cfm)	AVAILABLE EXTERNAL STATIC PRESSURE (in. wg)																			
	0.2		0.4		0.6		0.8		1.0		1.2		1.4		1.6		1.8		2.0	
	Rpm	Bhp	Rpm	Bhp	Rpm	Bhp	Rpm	Bhp	Rpm	Bhp	Rpm	Bhp	Rpm	Bhp	Rpm	Bhp	Rpm	Bhp	Rpm	Bhp
12,000	516	4.81	569	5.54	617	6.30	660	7.10	701	7.93	739	8.79	774	9.68	808	10.59	841	11.52	872	12.46
14,000	584	6.90	632	7.69	676	8.50	716	9.33	754	10.20	790	11.10	824	12.02	857	12.97	888	13.94	917	14.92
15,000	619	8.13	664	8.96	706	9.79	745	10.65	782	11.53	817	12.44	850	13.38	882	14.35	912	15.33	941	16.34
16,000	654	9.49	697	10.36	737	11.22	775	12.10	811	13.00	845	13.93	877	14.88	908	15.86	938	16.86	966	17.88
17,000	689	10.99	730	11.90	769	12.79	806	13.69	840	14.61	873	15.56	904	16.53	935	17.52	964	18.54	992	19.58
18,000	725	12.64	764	13.58	801	14.51	837	15.43	870	16.38	902	17.34	933	18.32	962	19.33	990	20.36	1018	21.41
19,000	760	14.43	798	15.41	834	16.37	868	17.32	900	18.29	932	19.27	961	20.27	990	21.29	1018	22.34	1045	23.40
20,000	796	16.37	833	17.39	867	18.39	900	19.37	931	20.36	962	21.36	991	22.38	1019	23.42	1046	24.48	1072	25.56
21,000	832	18.47	867	19.54	901	20.56	932	21.57	963	22.59	992	23.61	1020	24.65	1048	25.71	1074	26.78	1100	27.87
22,000	869	20.74	902	21.84	934	22.90	965	23.94	995	24.98	1023	26.03	1051	27.09	1077	28.17	1103	29.26	1129	30.36
23,000	905	23.17	937	24.31	968	25.40	998	26.48	1027	27.55	1055	28.62	1081	29.70	1107	30.79	1133	31.90	1157	33.02
24,000	942	25.78	973	26.95	1003	28.08	1032	29.18	1059	30.28	1086	31.38	1113	32.48	1138	33.59	1163	34.72	1187	35.86
25,000	978	28.56	1008	29.77	1037	30.93	1065	32.07	1092	33.20	1119	34.32	1144	35.44	1169	36.58	1193	37.72	—	—
26,000	1015	31.52	1044	32.76	1072	33.96	1099	35.13	1125	36.29	1151	37.44	1176	38.59	—	—	—	—	—	—
27,000	1052	34.66	1080	35.94	1107	37.18	1133	38.38	1159	39.57	1184	40.75	—	—	—	—	—	—	—	—

AIRFLOW (Cfm)	AVAILABLE EXTERNAL STATIC PRESSURE (in. wg)																			
	2.2		2.4		2.6		2.8		3.0		3.2		3.4		3.6		3.8		4.0	
	Rpm	Bhp	Rpm	Bhp	Rpm	Bhp	Rpm	Bhp	Rpm	Bhp	Rpm	Bhp	Rpm	Bhp	Rpm	Bhp	Rpm	Bhp	Rpm	Bhp
12,000	901	13.42	930	14.38	958	15.36	985	16.34	1011	17.33	1036	18.33	1061	19.33	1085	20.34	1108	21.35	1131	22.36
14,000	946	15.92	974	16.94	1001	17.97	1027	19.01	1052	20.06	1077	21.12	1101	22.18	1125	23.25	1148	24.33	1170	25.42
15,000	970	17.36	997	18.40	1024	19.45	1049	20.51	1074	21.58	1099	22.67	1122	23.76	1146	24.86	1168	25.97	1191	27.08
16,000	994	18.93	1021	19.98	1047	21.05	1072	22.14	1097	23.23	1121	24.34	1144	25.45	1167	26.58	1190	27.71	—	—
17,000	1019	20.63	1045	21.70	1071	22.79	1096	23.89	1120	25.01	1144	26.13	1167	27.27	1190	28.42	—	—	—	—
18,000	1045	22.48	1070	23.57	1096	24.67	1120	25.79	1144	26.93	1167	28.07	1190	29.23	—	—	—	—	—	—
19,000	1071	24.49	1096	25.59	1121	26.71	1145	27.84	1169	28.99	1192	30.16	—	—	—	—	—	—	—	—
20,000	1098	26.66	1123	27.77	1147	28.90	1171	30.05	1194	31.21	—	—	—	—	—	—	—	—	—	—
21,000	1125	28.99	1150	30.12	1173	31.26	1197	32.42	—	—	—	—	—	—	—	—	—	—	—	—
22,000	1153	31.49	1177	32.63	—	—	—	—	—	—	—	—	—	—	—	—	—	—	—	—
23,000	1181	34.16	—	—	—	—	—	—	—	—	—	—	—	—	—	—	—	—	—	—
24,000	—	—	—	—	—	—	—	—	—	—	—	—	—	—	—	—	—	—	—	—
25,000	—	—	—	—	—	—	—	—	—	—	—	—	—	—	—	—	—	—	—	—
26,000	—	—	—	—	—	—	—	—	—	—	—	—	—	—	—	—	—	—	—	—
27,000	—	—	—	—	—	—	—	—	—	—	—	—	—	—	—	—	—	—	—	—

**Table 30 — Fan Performance — 50AW,AY020,025 and 50A4,A5020 Units**

AIRFLOW (CFM)	AVAILABLE EXTERNAL STATIC PRESSURE (in. wg)																			
	0.2		0.4		0.6		0.8		1.0		1.2		1.4		1.6		1.8		2.0	
	Rpm	Bhp	Rpm	Bhp	Rpm	Bhp	Rpm	Bhp	Rpm	Bhp	Rpm	Bhp	Rpm	Bhp	Rpm	Bhp	Rpm	Bhp	Rpm	Bhp
4,000	322	0.62	399	0.82	464	1.04	521	1.26	572	1.48	619	1.71	662	1.93	702	2.16	739	2.38	774	2.61
5,000	361	0.95	431	1.17	491	1.41	545	1.65	594	1.89	640	2.14	682	2.39	722	2.64	759	2.89	795	3.14
6,000	405	1.41	467	1.64	524	1.88	574	2.14	621	2.40	664	2.67	705	2.93	744	3.20	780	3.47	816	3.75
7,000	451	2.00	508	2.22	559	2.48	607	2.75	651	3.02	693	3.30	732	3.58	769	3.87	804	4.16	839	4.45
7,500	475	2.34	529	2.57	579	2.82	625	3.10	668	3.38	708	3.66	746	3.96	783	4.25	818	4.55	851	4.84
8,000	500	2.72	551	2.95	598	3.21	643	3.48	685	3.77	724	4.06	762	4.36	797	4.66	832	4.96	864	5.27
9,000	550	3.60	596	3.83	640	4.09	682	4.36	721	4.66	759	4.96	795	5.27	829	5.58	862	5.90	893	6.22
10,000	601	4.63	644	4.86	684	5.12	723	5.40	760	5.70	796	6.01	830	6.33	863	6.65	894	6.98	925	7.31
11,000	653	5.83	692	6.07	730	6.33	766	6.61	801	6.91	835	7.22	867	7.54	899	7.87	929	8.21	958	8.55
12,000	706	7.20	742	7.45	777	7.71	811	7.99	844	8.29	875	8.61	906	8.93	936	9.27	966	9.61	994	9.96
12,500	732	7.96	768	8.20	801	8.47	834	8.75	866	9.05	897	9.37	927	9.69	956	10.03	985	10.38	1012	10.73
13,000	759	8.76	793	9.01	826	9.27	857	9.56	888	9.86	918	10.17	947	10.50	976	10.84	1004	11.19	1031	11.54

AIRFLOW (CFM)	AVAILABLE EXTERNAL STATIC PRESSURE (in. wg)																			
	2.2		2.4		2.6		2.8		3.0		3.2		3.4		3.6		3.8		4.0	
	Rpm	Bhp	Rpm	Bhp	Rpm	Bhp	Rpm	Bhp	Rpm	Bhp	Rpm	Bhp	Rpm	Bhp	Rpm	Bhp	Rpm	Bhp	Rpm	Bhp
4,000	808	2.84	840	3.06	870	3.29	900	3.52	928	3.75	955	3.98	981	4.21	1007	4.44	1031	4.67	1055	4.91
5,000	829	3.39	861	3.64	892	3.89	922	4.14	950	4.40	978	4.65	1005	4.90	1031	5.16	1056	5.41	1080	5.67
6,000	849	4.02	881	4.29	912	4.57	942	4.84	971	5.12	999	5.39	1026	5.67	1052	5.94	1077	6.22	1102	6.49
7,000	871	4.74	903	5.03	933	5.33	963	5.62	991	5.92	1019	6.21	1046	6.51	1072	6.80	1098	7.10	1123	7.40
7,500	883	5.14	915	5.44	945	5.75	974	6.05	1002	6.35	1030	6.66	1057	6.96	1083	7.27	1108	7.58	1133	7.88
8,000	896	5.58	927	5.89	957	6.20	985	6.51	1014	6.82	1041	7.13	1067	7.45	1093	7.76	1118	8.08	1143	8.39
9,000	924	6.54	954	6.86	983	7.19	1011	7.51	1038	7.84	1064	8.17	1090	8.50	1116	8.83	1141	9.16	1165	9.49
10,000	954	7.64	983	7.98	1011	8.31	1038	8.65	1065	8.99	1091	9.34	1116	9.68	1141	10.02	1165	10.37	1189	10.72
11,000	987	8.89	1015	9.24	1042	9.59	1068	9.94	1094	10.29	1119	10.65	1144	11.01	1168	11.36	1191	11.72	—	—
12,000	1022	10.31	1048	10.67	1075	11.03	1100	11.39	1125	11.75	1150	12.12	1173	12.48	1197	12.85	—	—	—	—
12,500	1039	11.08	1066	11.44	1092	11.81	1117	12.17	1141	12.54	1165	12.91	1189	13.28	—	—	—	—	—	—
13,000	1058	11.90	1084	12.26	1109	12.63	1134	13.00	1158	13.37	1182	13.75	—	—	—	—	—	—	—	—

**LEGEND**

- Bhp** — Brake Horsepower
- edb** — Entering Dry Bulb
- ewb** — Entering Wet Bulb

**NOTES:**

1. Fan performance is based on wet coils, economizer, roof curb, cabinet losses, and clean 2-in. filters.

2. Conversion — Bhp to watts:

$$\text{Watts} = \frac{\text{Bhp} \times 746}{\text{Motor efficiency}}$$

3. Variable air volume units will operate down to 70 cfm/ton. Performance at 70 cfm/ton is limited to unloaded operation and may be additionally limited by edb and ewb conditions.

**Table 31 — Fan Performance — 50AW,AY027,030 and 50A4,A5025-030 Units**

AIRFLOW (CFM)	AVAILABLE EXTERNAL STATIC PRESSURE (in. wg)																			
	0.2		0.4		0.6		0.8		1.0		1.2		1.4		1.6		1.8		2.0	
	Rpm	Bhp	Rpm	Bhp	Rpm	Bhp	Rpm	Bhp	Rpm	Bhp	Rpm	Bhp	Rpm	Bhp	Rpm	Bhp	Rpm	Bhp	Rpm	Bhp
4,000	325	0.62	402	0.83	466	1.05	523	1.27	574	1.49	620	1.72	663	1.94	703	2.17	740	2.39	776	2.62
5,000	366	0.97	435	1.19	495	1.42	548	1.67	597	1.91	642	2.16	685	2.41	724	2.65	762	2.90	797	3.16
6,000	411	1.43	473	1.66	529	1.91	579	2.16	625	2.43	668	2.69	709	2.96	747	3.23	784	3.50	819	3.77
7,000	459	2.02	515	2.25	566	2.51	613	2.78	657	3.06	698	3.34	737	3.62	774	3.91	809	4.20	843	4.49
8,000	508	2.76	559	2.99	606	3.25	650	3.53	691	3.82	731	4.11	768	4.41	803	4.71	837	5.01	870	5.32
9,000	560	3.64	605	3.88	649	4.14	690	4.42	729	4.72	766	5.02	802	5.33	835	5.64	868	5.96	900	6.28
10,000	612	4.68	654	4.92	694	5.19	732	5.47	769	5.77	804	6.09	838	6.40	870	6.73	902	7.06	932	7.39
11,000	665	5.89	703	6.14	740	6.41	776	6.69	811	7.00	844	7.31	876	7.64	907	7.97	937	8.31	967	8.65
12,000	718	7.28	754	7.53	788	7.80	822	8.09	854	8.39	886	8.71	916	9.04	946	9.38	975	9.72	1003	10.07
13,000	772	8.85	806	9.11	838	9.38	869	9.67	899	9.98	929	10.30	958	10.63	987	10.97	1014	11.32	1041	11.68
14,000	826	10.61	858	10.87	888	11.15	917	11.44	946	11.75	974	12.07	1002	12.41	1029	12.75	1055	13.10	1081	13.46
15,000	881	12.57	910	12.84	939	13.12	967	13.41	994	13.72	1021	14.05	1047	14.38	1073	14.73	1098	15.08	1123	15.45

AIRFLOW (CFM)	AVAILABLE EXTERNAL STATIC PRESSURE (in. wg)																			
	2.2		2.4		2.6		2.8		3.0		3.2		3.4		3.6		3.8		4.0	
	Rpm	Bhp	Rpm	Bhp	Rpm	Bhp	Rpm	Bhp	Rpm	Bhp	Rpm	Bhp	Rpm	Bhp	Rpm	Bhp	Rpm	Bhp	Rpm	Bhp
4,000	809	2.84	841	3.07	872	3.30	901	3.53	929	3.76	956	3.99	982	4.22	1008	4.45	1032	4.68	1056	4.92
5,000	831	3.41	863	3.66	894	3.91	924	4.16	952	4.41	980	4.67	1007	4.92	1032	5.17	1057	5.43	1082	5.68
6,000	852	4.05	884	4.32	915	4.59	945	4.87	974	5.14	1001	5.42	1028	5.69	1054	5.97	1080	6.24	1105	6.52
7,000	875	4.78	907	5.07	937	5.37	967	5.66	995	5.95	1023	6.25	1049	6.55	1076	6.84	1101	7.14	1126	7.44
8,000	901	5.63	932	5.94	961	6.25	990	6.56	1018	6.87	1045	7.18	1072	7.50	1097	7.81	1123	8.13	1147	8.44
9,000	930	6.60	960	6.93	988	7.25	1016	7.58	1043	7.91	1070	8.23	1096	8.57	1121	8.90	1146	9.23	1170	9.56
10,000	961	7.72	990	8.06	1018	8.40	1045	8.74	1071	9.08	1097	9.42	1122	9.76	1147	10.11	1171	10.46	1194	10.80
11,000	995	8.99	1022	9.34	1049	9.69	1075	10.04	1101	10.39	1126	10.75	1151	11.11	1175	11.47	1198	11.82	—	—
12,000	1030	10.43	1057	10.78	1083	11.14	1108	11.51	1133	11.87	1157	12.24	1181	12.61	—	—	—	—	—	—
13,000	1068	12.04	1093	12.40	1119	12.77	1143	13.14	1167	13.52	1191	13.89	—	—	—	—	—	—	—	—
14,000	1107	13.83	1131	14.20	1156	14.58	1179	14.96	—	—	—	—	—	—	—	—	—	—	—	—
15,000	1147	15.82	1171	16.19	1194	16.58	—	—	—	—	—	—	—	—	—	—	—	—	—	—

**Table 32 — Fan Performance — 50AW,AY,A4,A5035 Units**

AIRFLOW (Cfm)	AVAILABLE EXTERNAL STATIC PRESSURE (in. wg)																			
	0.2		0.4		0.6		0.8		1.0		1.2		1.4		1.6		1.8		2.0	
	Rpm	Bhp	Rpm	Bhp	Rpm	Bhp	Rpm	Bhp	Rpm	Bhp	Rpm	Bhp	Rpm	Bhp	Rpm	Bhp	Rpm	Bhp	Rpm	Bhp
7,000	522	2.06	573	2.32	620	2.57	664	2.82	705	3.06	744	3.30	780	3.54	815	3.78	849	4.01	881	4.24
8,000	576	2.75	622	3.03	665	3.30	706	3.57	745	3.84	782	4.10	817	4.36	850	4.62	883	4.87	914	5.12
9,000	630	3.57	672	3.86	712	4.16	750	4.45	787	4.74	822	5.02	855	5.30	888	5.58	919	5.86	949	6.13
10,000	686	4.52	724	4.84	761	5.15	797	5.46	831	5.77	864	6.07	896	6.37	927	6.67	957	6.97	986	7.26
10,500	714	5.05	750	5.38	786	5.70	821	6.02	854	6.34	886	6.65	917	6.96	947	7.27	977	7.57	1005	7.87
11,000	742	5.62	777	5.95	811	6.28	845	6.61	877	6.94	909	7.26	939	7.58	968	7.90	997	8.21	1025	8.52
12,000	799	6.88	831	7.22	863	7.57	894	7.91	925	8.25	954	8.60	983	8.93	1011	9.27	1039	9.60	1065	9.93
13,000	856	8.29	886	8.65	916	9.01	945	9.37	974	9.72	1002	10.08	1029	10.44	1056	10.79	1082	11.14	1108	11.49
14,000	914	9.87	942	10.24	969	10.61	997	10.98	1024	11.36	1050	11.73	1076	12.10	1102	12.47	1127	12.84	1152	13.20
15,000	971	11.62	998	12.00	1024	12.39	1050	12.77	1075	13.16	1100	13.54	1125	13.93	1149	14.31	1173	14.70	1197	15.08
16,000	1029	13.55	1054	13.94	1079	14.34	1103	14.74	1127	15.13	1151	15.53	1174	15.93	1198	16.33	1220	16.73	1243	17.12
17,000	1088	15.66	1111	16.07	1134	16.47	1157	16.88	1180	17.29	1203	17.70	1225	18.11	1247	18.53	1269	18.93	1290	19.34
17,500	1117	16.79	1140	17.20	1162	17.61	1184	18.02	1207	18.44	1229	18.86	1250	19.27	1272	19.69	1293	20.11	—	—

AIRFLOW (Cfm)	AVAILABLE EXTERNAL STATIC PRESSURE (in. wg)																			
	2.2		2.4		2.6		2.8		3.0		3.2		3.4		3.6		3.8		4.0	
	Rpm	Bhp	Rpm	Bhp	Rpm	Bhp	Rpm	Bhp	Rpm	Bhp	Rpm	Bhp	Rpm	Bhp	Rpm	Bhp	Rpm	Bhp	Rpm	Bhp
7,000	912	4.46	942	4.68	970	4.90	998	5.12	1025	5.33	1051	5.54	1076	5.75	1101	5.96	1124	6.16	1148	6.36
8,000	944	5.37	973	5.62	1001	5.86	1029	6.11	1055	6.35	1081	6.58	1106	6.82	1130	7.05	1154	7.28	1177	7.51
9,000	978	6.40	1006	6.67	1034	6.93	1060	7.20	1086	7.46	1112	7.72	1136	7.98	1160	8.23	1184	8.49	1207	8.74
10,000	1014	7.55	1041	7.84	1068	8.12	1094	8.41	1119	8.69	1144	8.97	1168	9.25	1192	9.52	1215	9.80	1238	10.07
10,500	1033	8.17	1059	8.47	1086	8.77	1111	9.06	1136	9.35	1161	9.64	1184	9.93	1208	10.22	1231	10.50	1253	10.79
11,000	1052	8.83	1078	9.14	1104	9.44	1129	9.75	1154	10.05	1178	10.35	1201	10.64	1224	10.94	1247	11.23	1269	11.53
12,000	1091	10.26	1117	10.58	1142	10.90	1166	11.23	1190	11.54	1213	11.86	1236	12.18	1259	12.49	1281	12.80	—	—
13,000	1133	11.83	1157	12.17	1181	12.51	1205	12.85	1228	13.19	1251	13.52	1273	13.86	1295	14.19	—	—	—	—
14,000	1176	13.56	1199	13.92	1222	14.28	1245	14.63	1268	14.99	1290	15.34	—	—	—	—	—	—	—	—
15,000	1220	15.45	1243	15.83	1265	16.20	1287	16.58	—	—	—	—	—	—	—	—	—	—	—	—
16,000	1265	17.52	1287	17.91	—	—	—	—	—	—	—	—	—	—	—	—	—	—	—	—
17,000	—	—	—	—	—	—	—	—	—	—	—	—	—	—	—	—	—	—	—	—
17,500	—	—	—	—	—	—	—	—	—	—	—	—	—	—	—	—	—	—	—	—

**LEGEND**  
**Bhp** — Brake Horsepower  
**edb** — Entering Dry Bulb  
**ewb** — Entering Wet Bulb

2. Conversion — Bhp to watts:

$$\text{Watts} = \frac{\text{Bhp} \times 746}{\text{Motor efficiency}}$$

**NOTES:**

1. Fan performance is based on wet coils, economizer, roof curb, cabinet losses, and clean 2-in. filters.

3. Variable air volume units will operate down to 70 cfm/ton. Performance at 70 cfm/ton is limited to unloaded operation and may be additionally limited by edb and ewb conditions.

**Table 33 — Fan Performance — 50AW,AY036 Units**

AIRFLOW (Cfm)	AVAILABLE EXTERNAL STATIC PRESSURE (in. wg)									
	0.2		0.4		0.6		0.8		1.0	
	Rpm	Bhp	Rpm	Bhp	Rpm	Bhp	Rpm	Bhp	Rpm	Bhp
7,000	451	2.13	503	2.49	552	2.86	597	3.23	641	3.60
8,000	499	2.88	546	3.27	590	3.66	632	4.06	672	4.46
9,000	548	3.78	591	4.20	631	4.62	670	5.04	708	5.47
10,000	599	4.86	637	5.30	675	5.74	711	6.19	746	6.64
11,000	649	6.11	685	6.57	720	7.04	753	7.51	786	7.99
12,000	701	7.54	734	8.03	766	8.52	797	9.02	828	9.52
13,000	753	9.18	783	9.69	813	10.21	842	10.72	871	11.25
14,000	805	11.03	833	11.56	861	12.09	889	12.63	916	13.18
15,000	857	13.09	884	13.64	910	14.20	936	14.76	962	15.32
16,000	910	15.38	935	15.95	960	16.53	984	17.11	1008	17.69
17,000	963	17.91	986	18.50	1010	19.09	1033	19.69	1056	20.30
17,500	989	19.26	1012	19.86	1035	20.47	1058	21.08	1080	21.69

AIRFLOW (Cfm)	AVAILABLE EXTERNAL STATIC PRESSURE (in. wg)									
	1.2		1.4		1.6		1.8		2.0	
	Rpm	Bhp	Rpm	Bhp	Rpm	Bhp	Rpm	Bhp	Rpm	Bhp
7,000	682	3.99	722	4.39	760	4.80	797	5.22	832	5.65
8,000	711	4.87	748	5.28	784	5.70	819	6.14	853	6.58
9,000	744	5.90	778	6.33	812	6.77	845	7.22	877	7.67
10,000	779	7.09	812	7.55	844	8.01	875	8.47	905	8.94
11,000	817	8.47	848	8.94	878	9.43	907	9.91	936	10.40
12,000	857	10.02	886	10.52	915	11.03	943	11.53	970	12.04
13,000	899	11.77	927	12.30	953	12.82	980	13.35	1006	13.88
14,000	942	13.73	968	14.27	994	14.82	1019	15.37	1044	15.92
15,000	987	15.89	1011	16.46	1036	17.03	1060	17.61	1083	18.18
16,000	1032	18.28	1056	18.87	1079	19.47	1101	20.06	1124	20.66
17,000	1078	20.91	1101	21.52	1123	22.13	1145	22.75	1166	23.36
17,500	1102	22.31	1124	22.93	1145	23.55	1166	24.18	1187	24.80

AIRFLOW (Cfm)	AVAILABLE EXTERNAL STATIC PRESSURE (in. wg)									
	2.2		2.4		2.6		2.8		3.0	
	Rpm	Bhp	Rpm	Bhp	Rpm	Bhp	Rpm	Bhp	Rpm	Bhp
7,000	866	6.09	899	6.54	931	6.99	961	7.45	991	7.91
8,000	885	7.03	917	7.48	948	7.95	978	8.42	1007	8.90
9,000	908	8.13	939	8.60	968	9.08	997	9.56	1026	10.05
10,000	934	9.42	963	9.90	992	10.39	1020	10.89	1047	11.39
11,000	964	10.89	992	11.39	1019	11.89	1045	12.40	1071	12.91
12,000	996	12.55	1023	13.07	1048	13.59	1074	14.11	1099	14.64
13,000	1031	14.41	1056	14.95	1081	15.48	1105	16.03	1129	16.57
14,000	1068	16.48	1092	17.03	1115	17.59	1138	18.15	1161	18.71
15,000	1106	18.75	1129	19.33	1151	19.91	1174	20.48	1196	21.07
16,000	1146	21.25	1168	21.85	1189	22.45	1211	23.04	1232	23.64
17,000	1187	23.98	1208	24.60	1229	25.21	1249	25.83	1270	26.46
17,500	1208	25.43	1229	26.06	1249	26.69	1269	27.32	1289	27.95

AIRFLOW (Cfm)	AVAILABLE EXTERNAL STATIC PRESSURE (in. wg)									
	3.2		3.4		3.6		3.8		4.0	
	Rpm	Bhp	Rpm	Bhp	Rpm	Bhp	Rpm	Bhp	Rpm	Bhp
7,000	1020	8.39	1047	8.86	1074	9.34	1101	9.83	1126	10.32
8,000	1036	9.39	1063	9.88	1090	10.38	1116	10.88	1142	11.39
9,000	1053	10.55	1080	11.05	1107	11.56	1133	12.08	1158	12.60
10,000	1073	11.89	1100	12.41	1125	12.93	1151	13.45	1175	13.99
11,000	1097	13.43	1122	13.96	1147	14.49	1171	15.02	1195	15.56
12,000	1123	15.17	1147	15.71	1171	16.25	1195	16.80	1218	17.35
13,000	1152	17.12	1175	17.67	1198	18.22	1221	18.78	1243	19.35
14,000	1184	19.27	1206	19.84	1228	20.41	1250	20.99	1271	21.56
15,000	1217	21.65	1239	22.23	1260	22.82	1280	23.41	—	—
16,000	1253	24.25	1273	24.85	1293	25.45	—	—	—	—
17,000	1289	27.07	—	—	—	—	—	—	—	—
17,500	—	—	—	—	—	—	—	—	—	—

**Table 34 — Fan Performance — 50AW,AY,A4,A5040 Units**

AIRFLOW (Cfm)	AVAILABLE EXTERNAL STATIC PRESSURE (in. wg)																			
	0.2		0.4		0.6		0.8		1.0		1.2		1.4		1.6		1.8		2.0	
	Rpm	Bhp	Rpm	Bhp	Rpm	Bhp	Rpm	Bhp	Rpm	Bhp	Rpm	Bhp	Rpm	Bhp	Rpm	Bhp	Rpm	Bhp	Rpm	Bhp
8,000	499	2.88	546	3.27	590	3.66	632	4.06	672	4.46	711	4.87	748	5.28	784	5.70	819	6.14	853	6.58
9,000	548	3.78	591	4.20	631	4.62	670	5.04	708	5.47	744	5.90	778	6.33	812	6.77	845	7.22	877	7.67
10,000	599	4.86	637	5.30	675	5.74	711	6.19	746	6.64	779	7.09	812	7.55	844	8.01	875	8.47	905	8.94
11,000	649	6.11	685	6.57	720	7.04	753	7.51	786	7.99	817	8.47	848	8.94	878	9.43	907	9.91	936	10.40
12,000	701	7.54	734	8.03	766	8.52	797	9.02	828	9.52	857	10.02	886	10.52	915	11.03	943	11.53	970	12.04
13,000	753	9.18	783	9.69	813	10.21	842	10.72	871	11.25	899	11.77	927	12.30	953	12.82	980	13.35	1006	13.88
14,000	805	11.03	833	11.56	861	12.09	889	12.63	916	13.18	942	13.73	968	14.27	994	14.82	1019	15.37	1044	15.92
15,000	857	13.09	884	13.64	910	14.20	936	14.76	962	15.32	987	15.89	1011	16.46	1036	17.03	1060	17.61	1083	18.18
16,000	910	15.38	935	15.95	960	16.53	984	17.11	1008	17.69	1032	18.28	1056	18.87	1079	19.47	1101	20.06	1124	20.66
17,000	963	17.91	986	18.50	1010	19.09	1033	19.69	1056	20.30	1078	20.91	1101	21.52	1123	22.13	1145	22.75	1166	23.36
18,000	1016	20.68	1038	21.29	1060	21.90	1082	22.52	1104	23.15	1126	23.77	1147	24.41	1168	25.04	1189	25.67	1209	26.31
19,000	1069	23.71	1090	24.33	1111	24.96	1132	25.60	1153	26.25	1173	26.89	1194	27.54	1214	28.19	1234	28.85	—	—
20,000	1122	26.99	1142	27.64	1162	28.29	1182	28.95	—	—	—	—	—	—	—	—	—	—	—	—

AIRFLOW (Cfm)	AVAILABLE EXTERNAL STATIC PRESSURE (in. wg)																			
	2.2		2.4		2.6		2.8		3.0		3.2		3.4		3.6		3.8		4.0	
	Rpm	Bhp	Rpm	Bhp	Rpm	Bhp	Rpm	Bhp	Rpm	Bhp	Rpm	Bhp	Rpm	Bhp	Rpm	Bhp	Rpm	Bhp	Rpm	Bhp
8,000	885	7.03	917	7.48	948	7.95	978	8.42	1007	8.90	1036	9.39	1063	9.88	1090	10.38	1116	10.88	1142	11.39
9,000	908	8.13	939	8.60	968	9.08	997	9.56	1026	10.05	1053	10.55	1080	11.05	1107	11.56	1133	12.08	1158	12.60
10,000	934	9.42	963	9.90	992	10.39	1020	10.89	1047	11.39	1073	11.89	1100	12.41	1125	12.93	1151	13.45	1175	13.99
11,000	964	10.89	992	11.39	1019	11.89	1045	12.40	1071	12.91	1097	13.43	1122	13.96	1147	14.49	1171	15.02	1195	15.56
12,000	996	12.55	1023	13.07	1048	13.59	1074	14.11	1099	14.64	1123	15.17	1147	15.71	1171	16.25	1195	16.80	1218	17.35
13,000	1031	14.41	1056	14.95	1081	15.48	1105	16.03	1129	16.57	1152	17.12	1175	17.67	1198	18.22	1221	18.78	1243	19.35
14,000	1068	16.48	1092	17.03	1115	17.59	1138	18.15	1161	18.71	1184	19.27	1206	19.84	1228	20.41	1250	20.99	1271	21.56
15,000	1106	18.75	1129	19.33	1151	19.91	1174	20.48	1196	21.07	1217	21.65	1239	22.23	1260	22.82	1280	23.41	—	—
16,000	1146	21.25	1168	21.85	1189	22.45	1211	23.04	1232	23.64	1253	24.25	1273	24.85	1293	25.45	—	—	—	—
17,000	1187	23.98	1208	24.60	1229	25.21	1249	25.83	1270	26.46	1289	27.07	—	—	—	—	—	—	—	—
18,000	1230	26.95	1250	27.58	1269	28.22	1289	28.86	—	—	—	—	—	—	—	—	—	—	—	—
19,000	—	—	—	—	—	—	—	—	—	—	—	—	—	—	—	—	—	—	—	—
20,000	—	—	—	—	—	—	—	—	—	—	—	—	—	—	—	—	—	—	—	—

**LEGEND**  
**bhp** — Brake Horsepower  
**edb** — Entering Dry Bulb  
**ewb** — Entering Wet Bulb

2. Conversion — Bhp to watts:

$$\text{Watts} = \frac{\text{Bhp} \times 746}{\text{Motor efficiency}}$$

**NOTES:**

1. Fan performance is based on wet coils, economizer, roof curb, cabinet losses, and clean 2-in. filters.

3. Variable air volume units will operate down to 70 cfm/ton. Performance at 70 cfm/ton is limited to unloaded operation and may be additional limited by edb and ewb conditions.



**Table 35 — Fan Performance — 50AW,AY041 Units**

AIRFLOW (Cfm)	AVAILABLE EXTERNAL STATIC PRESSURE (in. wg)									
	0.2		0.4		0.6		0.8		1.0	
	Rpm	Bhp	Rpm	Bhp	Rpm	Bhp	Rpm	Bhp	Rpm	Bhp
8,000	499	2.88	546	3.27	590	3.66	632	4.06	672	4.46
9,000	548	3.78	591	4.20	631	4.62	670	5.04	708	5.47
10,000	599	4.86	637	5.30	675	5.74	711	6.19	746	6.64
11,000	649	6.11	685	6.57	720	7.04	753	7.51	786	7.99
12,000	701	7.54	734	8.03	766	8.52	797	9.02	828	9.52
13,000	753	9.18	783	9.69	813	10.21	842	10.72	871	11.25
14,000	805	11.03	833	11.56	861	12.09	889	12.63	916	13.18
15,000	857	13.09	884	13.64	910	14.20	936	14.76	962	15.32
16,000	910	15.38	935	15.95	960	16.53	984	17.11	1008	17.69
17,000	963	17.91	986	18.50	1010	19.09	1033	19.69	1056	20.30
18,000	1016	20.71	1038	21.29	1060	21.90	1082	22.52	1104	23.15
19,000	1069	23.71	1090	24.33	1111	24.96	1132	25.60	1153	26.25
20,000	1122	26.99	1142	27.64	1162	28.29	1182	28.95	—	—

AIRFLOW (Cfm)	AVAILABLE EXTERNAL STATIC PRESSURE (in. wg)									
	1.2		1.4		1.6		1.8		2.0	
	Rpm	Bhp	Rpm	Bhp	Rpm	Bhp	Rpm	Bhp	Rpm	Bhp
8,000	711	4.87	748	5.28	784	5.70	819	6.14	853	6.58
9,000	744	5.90	778	6.33	812	6.77	845	7.22	877	7.67
10,000	779	7.09	812	7.55	844	8.01	875	8.47	905	8.94
11,000	817	8.47	848	8.94	878	9.43	907	9.91	936	10.40
12,000	857	10.02	886	10.52	915	11.03	943	11.53	970	12.04
13,000	899	11.77	927	12.30	953	12.82	980	13.35	1006	13.88
14,000	942	13.73	968	14.27	994	14.82	1019	15.37	1044	15.92
15,000	987	15.89	1011	16.46	1036	17.03	1060	17.61	1083	18.18
16,000	1032	18.28	1056	18.87	1079	19.47	1101	20.06	1124	20.66
17,000	1078	20.91	1101	21.52	1123	22.13	1145	22.75	1166	23.36
18,000	1126	23.77	1147	24.41	1168	25.04	1189	25.67	1209	26.31
19,000	1173	26.89	1194	27.54	1214	28.19	1234	28.85	—	—
20,000	—	—	—	—	—	—	—	—	—	—

AIRFLOW (Cfm)	AVAILABLE EXTERNAL STATIC PRESSURE (in. wg)									
	2.2		2.4		2.6		2.8		3.0	
	Rpm	Bhp	Rpm	Bhp	Rpm	Bhp	Rpm	Bhp	Rpm	Bhp
8,000	885	7.03	917	7.48	948	7.95	978	8.42	1007	8.90
9,000	908	8.13	939	8.60	968	9.08	997	9.56	1026	10.05
10,000	934	9.42	963	9.92	992	10.39	1020	10.89	1047	11.39
11,000	964	10.89	992	11.39	1019	11.89	1045	12.40	1071	12.91
12,000	996	12.55	1023	13.07	1048	13.59	1074	14.11	1099	14.64
13,000	1031	14.41	1056	14.95	1081	15.48	1105	16.03	1129	16.57
14,000	1068	16.48	1092	17.03	1115	17.59	1138	18.15	1161	18.71
15,000	1106	18.75	1129	19.33	1151	19.91	1174	20.48	1196	21.07
16,000	1146	21.25	1168	21.85	1189	22.45	1211	23.04	1232	23.64
17,000	1187	23.98	1208	24.60	1229	25.21	1249	25.83	1270	26.46
18,000	1230	26.95	1250	27.58	1269	28.22	1289	28.86	—	—
19,000	—	—	—	—	—	—	—	—	—	—
20,000	—	—	—	—	—	—	—	—	—	—

AIRFLOW (Cfm)	AVAILABLE EXTERNAL STATIC PRESSURE (in. wg)									
	3.2		3.4		3.6		3.8		4.0	
	Rpm	Bhp	Rpm	Bhp	Rpm	Bhp	Rpm	Bhp	Rpm	Bhp
8,000	1036	9.39	1063	9.88	1090	10.38	1116	10.88	1142	11.39
9,000	1053	10.55	1080	11.05	1107	11.56	1133	12.08	1158	12.60
10,000	1073	11.89	1100	12.41	1125	12.93	1151	13.45	1175	13.99
11,000	1097	13.43	1122	13.96	1147	14.49	1171	15.02	1195	15.56
12,000	1123	15.17	1147	15.71	1171	16.25	1195	16.80	1218	17.35
13,000	1152	17.12	1175	17.67	1198	18.22	1221	18.78	1243	19.35
14,000	1184	19.27	1206	19.84	1228	20.41	1250	20.99	1271	21.56
15,000	1217	21.65	1239	22.23	1260	22.82	1280	23.41	—	—
16,000	1253	24.25	1273	24.85	1293	25.45	—	—	—	—
17,000	1289	27.07	—	—	—	—	—	—	—	—
18,000	—	—	—	—	—	—	—	—	—	—
19,000	—	—	—	—	—	—	—	—	—	—
20,000	—	—	—	—	—	—	—	—	—	—

**Table 36 — Fan Performance — 50AW,AY,A4,A5050 Units**

AIRFLOW (Cfm)	AVAILABLE EXTERNAL STATIC PRESSURE (in. wg)																			
	0.2		0.4		0.6		0.8		1.0		1.2		1.4		1.6		1.8		2.0	
	Rpm	Bhp	Rpm	Bhp	Rpm	Bhp	Rpm	Bhp	Rpm	Bhp	Rpm	Bhp	Rpm	Bhp	Rpm	Bhp	Rpm	Bhp	Rpm	Bhp
8,000	509	2.95	555	3.35	599	3.74	640	4.14	680	4.54	718	4.95	755	5.36	791	5.79	826	6.22	859	6.66
9,000	558	3.87	600	4.29	640	4.71	678	5.13	715	5.56	751	5.99	786	6.42	819	6.87	852	7.31	884	7.77
10,000	608	4.96	646	5.40	683	5.85	719	6.30	754	6.75	787	7.20	819	7.66	851	8.12	882	8.58	912	9.06
11,000	659	6.23	694	6.69	728	7.16	762	7.64	794	8.11	825	8.59	856	9.07	886	9.55	915	10.04	943	10.53
12,000	710	7.68	743	8.17	775	8.67	806	9.17	836	9.67	866	10.17	895	10.67	923	11.17	950	11.68	978	12.19
13,000	763	9.35	793	9.86	823	10.37	852	10.89	880	11.42	908	11.94	935	12.47	962	12.99	988	13.52	1014	14.05
14,000	815	11.22	843	11.75	871	12.29	899	12.83	925	13.38	952	13.92	978	14.47	1003	15.02	1028	15.57	1052	16.12
15,000	868	13.31	895	13.86	921	14.42	946	14.98	972	15.55	997	16.12	1021	16.69	1045	17.26	1069	17.83	1092	18.41
16,000	921	15.64	946	16.21	971	16.78	995	17.37	1019	17.96	1043	18.54	1066	19.14	1089	19.73	1111	20.32	1134	20.92
17,000	974	18.20	998	18.79	1021	19.39	1044	19.99	1067	20.60	1089	21.21	1112	21.82	1134	22.43	1155	23.05	1176	23.66
18,000	1028	21.01	1050	21.62	1072	22.24	1094	22.86	1116	23.49	1137	24.12	1158	24.75	1179	25.38	1200	26.02	1220	26.65
19,000	1081	24.08	1103	24.71	1124	25.35	1145	25.99	1165	26.63	1185	27.28	1206	27.93	1226	28.58	1245	29.24	1265	29.90
20,000	1135	27.42	1155	28.06	1175	28.72	1195	29.38	1215	30.04	1234	30.71	1254	31.38	1273	32.05	1292	32.72	—	—

AIRFLOW (Cfm)	AVAILABLE EXTERNAL STATIC PRESSURE (in. wg)																			
	2.2		2.4		2.6		2.8		3.0		3.2		3.4		3.6		3.8		4.0	
	Rpm	Bhp	Rpm	Bhp	Rpm	Bhp	Rpm	Bhp	Rpm	Bhp	Rpm	Bhp	Rpm	Bhp	Rpm	Bhp	Rpm	Bhp	Rpm	Bhp
8,000	892	7.12	923	7.57	954	8.04	984	8.52	1013	9.00	1041	9.49	1069	9.98	1095	10.48	1121	10.98	1147	11.49
9,000	915	8.23	945	8.70	975	9.18	1003	9.67	1032	10.16	1059	10.66	1086	11.16	1112	11.67	1138	12.19	1163	12.71
10,000	941	9.53	970	10.02	998	10.51	1026	11.00	1053	11.51	1080	12.01	1106	12.53	1131	13.05	1156	13.58	1181	14.11
11,000	971	11.02	999	11.52	1026	12.02	1052	12.53	1078	13.05	1103	13.57	1128	14.09	1153	14.63	1177	15.16	1201	15.71
12,000	1004	12.70	1030	13.22	1056	13.74	1081	14.26	1106	14.79	1130	15.33	1154	15.86	1178	16.41	1201	16.96	1224	17.51
13,000	1039	14.59	1064	15.12	1088	15.66	1113	16.20	1136	16.74	1160	17.29	1183	17.85	1206	18.40	1228	18.96	1250	19.53
14,000	1076	16.68	1100	17.23	1123	17.79	1147	18.35	1169	18.91	1192	19.48	1214	20.04	1236	20.62	1257	21.19	1279	21.77
15,000	1115	18.98	1138	19.56	1160	20.14	1182	20.72	1204	21.30	1226	21.88	1247	22.47	1268	23.05	1289	23.65	—	—
16,000	1156	21.52	1178	22.11	1199	22.71	1220	23.31	1241	23.91	1262	24.51	1282	25.12	—	—	—	—	—	—
17,000	1198	24.28	1218	24.90	1239	25.52	1259	26.14	1279	26.76	1299	27.38	—	—	—	—	—	—	—	—
18,000	1240	27.29	1260	27.93	1280	28.57	1300	29.21	—	—	—	—	—	—	—	—	—	—	—	—
19,000	1284	30.55	—	—	—	—	—	—	—	—	—	—	—	—	—	—	—	—	—	—
20,000	—	—	—	—	—	—	—	—	—	—	—	—	—	—	—	—	—	—	—	—

LEGEND  
**Bhp** — Brake Horsepower  
**edb** — Entering Dry Bulb  
**ewb** — Entering Wet Bulb

NOTES:  
 1. Fan performance is based on wet coils, economizer, roof curb, cabinet losses, and clean 2-in. filters.  
 2. Conversion — Bhp to watts:  

$$\text{Watts} = \frac{\text{Bhp} \times 746}{\text{Motor efficiency}}$$
  
 3. Variable air volume units will operate down to 70 cfm/ton. Performance at 70 cfm/ton is limited to unloaded operation and may be additionally limited by edb and ewb conditions.

**Table 37 — Fan Performance — 50AW,AY051 Units**

AIRFLOW (Cfm)	AVAILABLE EXTERNAL STATIC PRESSURE (in. wg)									
	0.2		0.4		0.6		0.8		1.0	
	Rpm	Bhp	Rpm	Bhp	Rpm	Bhp	Rpm	Bhp	Rpm	Bhp
10,000	429	2.98	488	3.61	539	4.26	585	4.95	627	5.66
12,000	490	4.48	543	5.17	591	5.88	634	6.61	673	7.36
13,000	522	5.39	572	6.11	618	6.85	659	7.61	698	8.38
14,000	554	6.41	602	7.17	645	7.94	686	8.72	723	9.51
15,000	586	7.56	632	8.34	674	9.14	713	9.94	749	10.77
16,000	619	8.83	663	9.64	703	10.46	741	11.30	776	12.14
17,000	652	10.23	694	11.07	733	11.92	769	12.78	803	13.65
18,000	685	11.76	725	12.63	763	13.51	798	14.39	831	15.29
19,000	719	13.44	757	14.33	793	15.23	827	16.14	860	17.07
20,000	753	15.26	789	16.18	824	17.10	857	18.04	888	18.99
21,000	787	17.23	822	18.17	855	19.12	887	20.08	918	21.05
22,000	821	19.35	855	20.32	887	21.29	918	22.28	947	23.28
23,000	855	21.63	888	22.62	919	23.62	949	24.63	977	25.65
24,000	889	24.07	921	25.08	951	26.11	980	27.14	1008	28.19
25,000	924	26.67	954	27.71	983	28.76	1011	29.82	1038	30.89

AIRFLOW (Cfm)	AVAILABLE EXTERNAL STATIC PRESSURE (in. wg)									
	1.2		1.4		1.6		1.8		2.0	
	Rpm	Bhp	Rpm	Bhp	Rpm	Bhp	Rpm	Bhp	Rpm	Bhp
10,000	666	6.41	703	7.17	737	7.96	770	8.78	801	9.61
12,000	711	8.14	746	8.94	779	9.76	811	10.60	841	11.45
13,000	734	9.18	769	9.99	801	10.82	832	11.68	862	12.55
14,000	759	10.33	792	11.16	824	12.01	855	12.88	884	13.76
15,000	784	11.60	816	12.45	848	13.32	878	14.21	906	15.11
16,000	810	13.00	841	13.87	872	14.76	901	15.66	929	16.58
17,000	836	14.53	867	15.42	897	16.33	926	17.25	953	18.19
18,000	863	16.20	893	17.11	922	18.04	950	18.98	978	19.93
19,000	890	18.00	920	18.94	949	19.88	976	20.84	1003	21.81
20,000	918	19.94	947	20.90	975	21.87	1002	22.85	1028	23.84
21,000	947	22.03	975	23.02	1002	24.01	1029	25.01	1054	26.02
22,000	976	24.28	1003	25.28	1030	26.30	1056	27.32	1081	28.35
23,000	1005	26.68	1032	27.71	1058	28.75	1083	29.79	1108	30.85
24,000	1035	29.24	1061	30.29	1086	31.35	1111	32.42	1135	33.49
25,000	1065	31.96	1090	33.04	1115	34.12	1139	35.21	1163	36.31

AIRFLOW (Cfm)	AVAILABLE EXTERNAL STATIC PRESSURE (in. wg)									
	2.2		2.4		2.6		2.8		3.0	
	Rpm	Bhp	Rpm	Bhp	Rpm	Bhp	Rpm	Bhp	Rpm	Bhp
10,000	831	10.46	860	11.33	888	12.21	915	13.11	941	14.02
12,000	870	12.33	898	13.22	925	14.13	951	15.06	977	16.00
13,000	891	13.44	918	14.35	945	15.27	971	16.20	996	17.16
14,000	912	14.67	939	15.59	965	16.52	991	17.47	1018	18.44
15,000	934	16.02	961	16.96	987	17.90	1012	18.87	1036	19.84
16,000	957	17.51	983	18.46	1008	19.42	1033	20.39	1057	21.38
17,000	980	19.13	1006	20.10	1031	21.07	1055	22.06	1079	23.06
18,000	1004	20.89	1029	21.87	1054	22.86	1078	23.86	1101	24.88
19,000	1028	22.80	1053	23.79	1078	24.80	1101	25.81	1124	26.84
20,000	1053	24.85	1078	25.86	1102	26.88	1125	27.91	1148	28.96
21,000	1079	27.04	1103	28.07	1126	29.11	1149	30.16	1172	31.22
22,000	1105	29.39	1129	30.44	1152	31.50	1174	32.57	1196	33.65
23,000	1131	31.90	1155	32.97	1177	34.05	1199	35.13	—	—
24,000	1158	34.57	1181	35.66	—	—	—	—	—	—
25,000	1186	37.41	—	—	—	—	—	—	—	—

AIRFLOW (Cfm)	AVAILABLE EXTERNAL STATIC PRESSURE (in. wg)									
	3.2		3.4		3.6		3.8		4.0	
	Rpm	Bhp	Rpm	Bhp	Rpm	Bhp	Rpm	Bhp	Rpm	Bhp
10,000	966	14.94	991	15.88	1014	16.83	1038	17.79	1060	18.76
12,000	1002	16.96	1026	17.92	1049	18.90	1072	19.89	1094	20.89
13,000	1020	18.13	1044	19.11	1067	20.10	1090	21.10	1112	22.12
14,000	1040	19.42	1063	20.41	1086	21.41	1109	22.43	1131	23.46
15,000	1060	20.83	1083	21.84	1106	22.85	1128	23.88	1150	24.92
16,000	1081	22.39	1104	23.40	1126	24.43	1148	25.47	1170	26.52
17,000	1102	24.07	1125	25.10	1147	26.14	1169	27.19	1190	28.26
18,000	1124	25.91	1147	26.94	1169	28.00	1190	29.06	—	—
19,000	1147	27.89	1169	28.94	1190	30.00	—	—	—	—
20,000	1170	30.01	1192	31.08	—	—	—	—	—	—
21,000	1194	32.30	—	—	—	—	—	—	—	—
22,000	—	—	—	—	—	—	—	—	—	—
23,000	—	—	—	—	—	—	—	—	—	—
24,000	—	—	—	—	—	—	—	—	—	—
25,000	—	—	—	—	—	—	—	—	—	—

**Table 38 — Fan Performance — 50AW,AY,A4,A5060 Units**

AIRFLOW (Cfm)	AVAILABLE EXTERNAL STATIC PRESSURE (in. wg)																			
	0.2		0.4		0.6		0.8		1.0		1.2		1.4		1.6		1.8		2.0	
	Rpm	Bhp	Rpm	Bhp	Rpm	Bhp	Rpm	Bhp	Rpm	Bhp	Rpm	Bhp	Rpm	Bhp	Rpm	Bhp	Rpm	Bhp	Rpm	Bhp
12,000	490	4.48	543	5.17	591	5.88	634	6.61	674	7.37	711	8.14	746	8.94	779	9.76	811	10.60	841	11.45
14,000	554	6.41	602	7.17	645	7.94	686	8.72	723	9.51	759	10.33	792	11.16	824	12.01	855	12.88	884	13.76
15,000	586	7.56	632	8.34	674	9.14	713	9.94	749	10.77	784	11.60	816	12.45	848	13.32	878	14.21	906	15.11
16,000	619	8.83	663	9.64	703	10.46	741	11.30	776	12.14	810	13.00	841	13.87	872	14.76	901	15.66	929	16.58
17,000	652	10.23	694	11.07	733	11.92	769	12.78	803	13.65	836	14.53	867	15.42	897	16.33	926	17.25	953	18.19
18,000	685	11.76	725	12.63	763	13.51	798	14.39	831	15.29	863	16.20	893	17.11	922	18.04	950	18.98	978	19.93
19,000	719	13.44	757	14.33	793	15.23	827	16.14	860	17.07	890	18.00	920	18.94	949	19.88	976	20.84	1003	21.81
20,000	753	15.26	789	16.18	824	17.10	857	18.04	888	18.99	918	19.94	947	20.90	975	21.87	1002	22.85	1028	23.84
21,000	787	17.23	822	18.17	855	19.12	887	20.08	918	21.05	947	22.03	975	23.02	1002	24.01	1029	25.01	1054	26.02
22,000	821	19.35	855	20.32	887	21.29	918	22.28	947	23.28	976	24.28	1003	25.28	1030	26.30	1056	27.32	1081	28.35
23,000	855	21.63	888	22.62	919	23.62	949	24.63	977	25.65	1005	26.68	1032	27.71	1058	28.75	1083	29.79	1108	30.85
24,000	889	24.07	921	25.08	951	26.11	980	27.14	1008	28.19	1035	29.24	1061	30.29	1086	31.35	1111	32.42	1135	33.49
25,000	924	26.67	954	27.71	983	28.76	1011	29.82	1038	30.89	1065	31.96	1090	33.04	1115	34.12	1139	35.21	1163	36.31
26,000	958	29.45	987	30.51	1016	31.59	1043	32.67	1069	33.76	1095	34.85	1120	35.95	1144	37.06	1168	38.17	1191	39.29
27,000	993	32.40	1021	33.49	1048	34.58	1075	35.69	1101	36.80	1126	37.92	1150	39.04	1174	40.17	1197	41.30	—	—

AIRFLOW (Cfm)	AVAILABLE EXTERNAL STATIC PRESSURE (in. wg)																			
	2.2		2.4		2.6		2.8		3.0		3.2		3.4		3.6		3.8		4.0	
	Rpm	Bhp	Rpm	Bhp	Rpm	Bhp	Rpm	Bhp	Rpm	Bhp	Rpm	Bhp	Rpm	Bhp	Rpm	Bhp	Rpm	Bhp	Rpm	Bhp
12,000	870	12.33	898	13.22	925	14.13	951	15.06	977	16.00	1002	16.96	1026	17.92	1049	18.90	1072	19.89	1094	20.89
14,000	912	14.67	939	15.59	965	16.52	991	17.47	1016	18.44	1040	19.42	1063	20.41	1086	21.41	1109	22.43	1131	23.46
15,000	934	16.02	961	16.96	987	17.90	1012	18.87	1036	19.84	1060	20.83	1083	21.84	1106	22.85	1128	23.88	1150	24.92
16,000	957	17.51	983	18.46	1008	19.42	1033	20.39	1057	21.38	1081	22.39	1104	23.40	1126	24.43	1148	25.47	1170	26.52
17,000	980	19.13	1006	20.10	1031	21.07	1055	22.06	1079	23.06	1102	24.07	1125	25.10	1147	26.14	1169	27.19	1190	28.26
18,000	1004	20.89	1029	21.87	1054	22.86	1078	23.86	1101	24.88	1124	25.91	1147	26.94	1169	28.00	1190	29.06	—	—
19,000	1028	22.80	1053	23.79	1078	24.80	1101	25.81	1124	26.84	1147	27.89	1169	28.94	1190	30.00	—	—	—	—
20,000	1053	24.85	1078	25.86	1102	26.88	1125	27.91	1148	2										

**Table 39 — Motor Limitations**

HIGH-EFFICIENCY MOTORS								
Nominal		Maximum		Maximum Amps			Maximum Watts	Maximum Efficiency
Bhp	BkW	Bhp	BkW	230 v	460 v	575 v		
5	3.73	5.9	4.40	15.0	7.9	6.0	5,030	87.5
		8.7	6.49	23.5	—	—	7,717	84.1
7.5	5.6	9.5	7.09	—	12.0	10.0	8,008	88.5
		10.2	7.61	31.0	—	—	9,502	89.5
10	7.46	11.8	8.80	—	15.0	12.0	9,836	89.5
		15.3	11.41	46.0	—	—	12,543	91.0
15	11.19	18.0	13.43	—	22.0	19.0	14,756	91.0
		22.4	16.71	60.0	—	—	18,363	91.0
20	14.92	23.4	17.46	—	28.7	23.0	19,183	91.0
		28.9	21.56	73.0	—	—	23,511	91.7
25	18.65	29.4	21.93	—	37.4	28.4	23,918	91.7
		35.6	26.56	91.0	—	—	28,742	92.4
30	22.38	34.7	25.89	—	43.8	36.3	28,015	92.4
		40	29.84	42.0	31.33	110.0	55.0	33,690

PREMIUM-EFFICIENCY MOTORS								
Nominal		Maximum		Maximum Amps		Maximum Watts	Maximum Efficiency	
Bhp	BkW	Bhp	BkW	230 v	460 v			
5	3.73	5.9	4.40	15.8	7.9	4,918	89.5	
		8.7	6.49	23.5	—	—	7,078	91.7
7.5	5.6	9.5	7.09	—	12.0	7,728	91.7	
		10.2	7.61	30.0	—	—	8,298	91.0
10	7.46	11.8	8.80	—	15.0	9,600	91.7	
		15.3	11.41	46.0	—	—	12,273	91.7
15	11.19	18.0	13.43	—	22.0	14,439	93.0	
		22.4	16.71	59.0	—	—	17,853	93.0
20	14.92	23.4	17.46	—	28.7	18,650	93.6	
		28.9	21.56	73.0	—	—	23,034	93.6
25	18.65	29.4	21.93	—	36.3	23,432	93.6	
		35.6	26.56	82.6	—	—	28,374	93.6
30	22.38	34.7	25.89	—	41.7	27,656	93.6	
		40	29.84	42.0	31.33	110.0	55.0	33,156

LEGEND

- Bhp — Brake Horsepower
- BkW — Brake Kilowatts

Using the fan motors up to the horsepower ratings shown in the Motor Limitations table will not result in nuisance tripping or premature motor failures. Unit warranty will not be affected.

2. All motors comply with Energy Policy Act (EPACT) Standards effective October 24, 1997.

NOTES:

1. Extensive motor and electrical testing on the Carrier units has ensured that the full horsepower range of the motor can be utilized with confidence.

**Table 40A — Air Quantity Limits (48AJ,AK,AW,AY,A2,A3,A4,A5) SAV at 100% speed**

UNIT SIZE*	MINIMUM HEATING AIRFLOW CFM (Low Heat)	MINIMUM HEATING AIRFLOW CFM (High Heat)	MINIMUM COOLING AIRFLOW (VAV) CFM AT FULL LOAD	MINIMUM COOLING AIRFLOW CFM (CV AND SAV)	MAXIMUM AIRFLOW CFM
020	5,900	6,100	4,000	6,000	10,000
025	5,900	6,100	5,000	7,500	12,500
027	5,900	6,100	5,400	8,100	13,500
030	5,900	6,100	6,000	9,000	15,000
035 (A,J,AK,AW,AY)	5,900	6,100	7,000	10,500	17,500
035 (A2,A3,A4,A5)	5,900	10,100	7,000	10,500	17,500
036,040,041	7,600	10,100	8,000	12,000	20,000
050	7,600	10,100	10,000	15,000	22,500
051,060	11,000	10,100	12,000	18,000	27,000

\* Sizes 036,041, and 051 are 48AJ,AK,AW,AY only.

LEGEND

- CV — Constant Volume
- SAV — Staged Air Volume
- VAV — Variable Air Volume

NOTE: Variable air volume units will operate down to 70 cfm/ton in Cooling mode. Performance at 70 cfm/ton is limited to unloaded operation and may be also limited by edb (entering dry bulb) and ewb (entering wet bulb) conditions.

**Table 40B — Air Quantity Limits (50AJ,AK,AW,AY,A2,A3,A4,A5)**

UNIT	COOLING		ELECTRIC HEAT	
	Min CFM	Max CFM*	Min CFM	Max CFM
50AJ,AW,A2,A3020	6,000	10,000	6,000	15,000
50AK,AY,A4,A5020	4,000	10,000		
50AJ,AW,A2,A3025	7,500	12,500		
50AK,AY,A4,A5025	5,000	12,500		
50AJ,AW,A2,A4027	8,100	13,500		
50AK,AY,A3,A5027	5,400	13,500		
50AJ,AW,A2,A4030	9,000	15,000		
50AK,AY,A3,A5030	6,000	15,000		
50AJ,AW,A2,A4035	10,500	17,500		
50AJ,AW036	10,500	17,500		
50AK,AY,A3,A5035	7,000	17,500		
50AK,AY036	7,000	17,500		
50AJ,AW,A2,A4040	12,000	20,000		
50AJ,AW041	12,000	20,000		
50AK,AY,A3,A5040	8,000	20,000		
50AK,AY041	8,000	20,000		
50AJ,AW,A2,A4050	13,500	20,000		
50AK,AY,A3,A5050	10,000	20,000		
50AJ,AW051	18,000	27,000		
50AJ,AW,A2,A4060	18,000	27,000		
50AK,AY051	12,000	27,000		
50AK,AY,A3,A5060	12,000	27,000		

\*Operation at these levels may be limited by entering evaporator air wet bulb temperatures.

### CONTROLS QUICK START

The following section will provide a quick user guide to setting up and configuring the A Series units with *ComfortLink* controls. See Basic Control Usage section on page 3 for information on operating the control. For wiring information, refer to unit wiring diagrams in the Major System Components section on page 102.

**IMPORTANT:** The *ComfortLink* controls provide the user with numerous configuration options such as set points, demand levels, reset, and many others. If the building owner or design engineer has not provided specific recommendations for these configuration settings, it is suggested that the installer does not make changes to the default factory settings. The factory-configured default values are appropriate for many applications.

**IMPORTANT:** The unit is shipped with the unit control disabled. Enable the control by setting Local Machine Disable (*Service Test* → *STOP*) to No.

**Two-Stage Constant Volume Units with Mechanical Thermostat** — To configure the unit, perform the following:

1. The type of control is configured under *Configuration* → *UNIT* → *C.TYP*. Set *C.TYP* to 4 (TSTAT 2 STG).
2. Remove jumpers from R-W2 and W2-W1 on TB4 in the control box.
3. See Economizer Options section on page 28 for additional economizer option configurations.
4. See Exhaust Options section on page 29 for additional exhaust option configurations.

**Two-Stage Constant Volume Units with Space Sensor** — To configure the unit, perform the following:

1. The type of control is configured under *Configuration* → *UNIT* → *C.TYP*. Set *C.TYP* to 6 (SPT 2 STG).
2. Under *Configuration* → *UNIT* → *SENS* → *SPTS*, enable the space sensor by setting *SPTS* to ENBL (enable).
3. Install jumpers between R-W2 and W2-W1 on TB4 in the control box.
4. The space temperature set points are configured under the *Setpoints* menu. The heating and cooling set points may

be configured. See the Heating Control and Cooling Control sections on pages 50 and 37 for further description on these configurations. The following set points may be configured:

- OHSP** Occupied Heat Setpoint
- OCSP** Occupied Cool Setpoint
- UHSP** Unoccupied Heat Setpoint
- UCSP** Unoccupied Cool Setpoint
- GAP** Heat-Cool Setpoint Gap

5. The degrees of demand from the space temperature set points are configured under the *Configuration* → *D.LV.T* submenu. See the Heating Control and Cooling Control sections for further description on these configurations. The following set points may be configured:

- L.H.ON** Demand Level Lo Heat On
- H.H.ON** Demand Level Hi Heat On
- L.H.OF** Demand Level Lo Heat Off
- L.C.ON** Demand Level Lo Cool On
- H.C.ON** Demand Level Hi Cool On
- L.C.OF** Demand Level Lo Cool Off

6. Under *Configuration* → *UNIT* → *CV.FN*, set *CV.FN* to 1 for continuous fan or 0 for automatic fan.
7. To program time schedules, set *SCH.N*=1 under *Configuration* → *CCN* → *SC.OV* → *SCH.N* to configure the control to use local schedules.
8. Under the *Timeclock* → *SCH.L* submenu, enter the desired schedule. See Time Clock Configuration section on page 76 for further description of these configurations.
9. Under the *Configuration* → *CCN* → *SC.OV* submenu, the following schedules and overrides should be configured:

- O.T.L.** Override time limit
- SPT.O** SPT override enabled?
- T58.O** T58 override enabled?

10. See Economizer Options section on page 28 for additional economizer option configurations.
11. See Exhaust Options section on page 29 for additional exhaust option configurations.

**Variable Air Volume Units Using Return Air Sensor or Space Temperature Sensor** — To configure the unit, perform the following:

1. The type of control is configured under **Configuration** → **UNIT** → **C.TYP**. Set **C.TYP** to 1 (VAV-RAT) for return air sensor. Set **C.TYP** to 2 (VAV-SPT) for space temperature sensor.

NOTE: For VAV with a space sensor (VAV-SPT), under **Configuration** → **UNIT** → **SENS** → **SPTS**, enable the space sensor by setting **SPTS** to ENBL.

2. Install jumpers between R-W2 and W2-W1 on TB4 in the control box.
3. The space temperature set points and the supply air set points are configured under the **Setpoints** menu. The heating and cooling set points must be configured. See the Heating Control and Cooling Control sections for further description on these configurations. Configure the following set points:

**OHSP** Occupied Heat Setpoint  
**OCSP** Occupied Cool Setpoint  
**UHSP** Unoccupied Heat Setpoint  
**V.C.ON** VAV Occupied Cool On Delta  
**V.C.OF** VAV Occupied Cool Off Delta  
**SASP** Supply Air Setpoint

4. To program time schedules, make sure **SCH.N**=1 under **Configuration** → **CCN** → **SC.OV** → **SCH.N** to configure the control to use local schedules.
5. Under the **Timeclock** → **SCH.L** submenu, enter the desired schedule. See Time Clock Configuration section on page 76 for further description of these configurations.
6. Under **Configuration** → **SP** → **SP.SP**, the supply duct Static Pressure Setpoint should be configured.

**SP.SP** Static Pressure Setpoint

7. If supply air temperature reset is desired, under the **Configuration** → **EDT.R** submenu, the following set points should be configured:

**RS.CF** EDT Reset Configuration  
**RTIO** Reset Ratio (if **RS.CF** = 1 or 2)  
**LIMT** Reset Limit (if **RS.CF** = 1 or 2)  
**RES.S** EDT 4-20 mA Reset Input (if **RS.CF** = 3)

NOTE: Configure either **RTIO** and **LIMT** or **RES.S**. All three are not used.

8. See the Economizer Options section on this page for additional economizer option configurations.
9. See the Exhaust Options section on page 29 for additional exhaust option configurations.

**Multi-Stage Constant Volume Units with Mechanical Thermostat** — To configure the unit, perform the following:

1. Under **Configuration** → **UNIT** → **C.TYP**, set **C.TYP** to 3 (TSTAT MULTI).
2. Remove jumpers from R-W2 and W2-W1 on TB4 in the control box. Connect thermostat to TB4.
3. Under the **Setpoints** menu, set the following configurations:

**SA.HI** Supply Air Set Point Hi  
**SA.LO** Supply Air Set Point Lo

4. See the Economizer Options section on this page for additional economizer option configurations.

5. See the Exhaust Options section on page 29 for additional exhaust option configurations.

**Multi-Stage Constant Volume Units with Space Sensor** — To configure the unit, perform the following:

1. Under **Configuration** → **UNIT** → **C.TYP**, set **C.TYP** to 5 (SPT MULTI).
2. Install jumpers between R-W2 and W2-W1 on TB4 in the control box.
3. Under the **Setpoints** menu, the following configurations should be set:

**OHSP** Occupied Heat Setpoint  
**OCSP** Occupied Cool Setpoint  
**UHSP** Unoccupied Heat Setpoint  
**UCSP** Unoccupied Cool Setpoint  
**GAP** Heat-Cool Setpoint Gap  
**SA.HI** Supply Air Set Point Hi  
**SA.LO** Supply Air Set Point Lo

4. The degrees of demand from the space temperature set points are configured under the **Configuration** → **D.LVT** submenu. See the Heating Control and Cooling Control sections for further description on these configurations. Configure the following set points:

**L.H.ON** Demand Level Lo Heat On  
**H.H.ON** Demand Level Hi Heat On  
**L.H.OF** Demand Level Lo Heat On  
**L.C.ON** Demand Level Lo Cool On  
**H.C.ON** Demand Level Hi Cool On  
**L.C.OF** Demand Level Lo Cool On

5. Under **Configuration** → **UNIT** → **SENS** → **SPTS**, enable the space sensor by setting **SPTS** to ENBL.
6. Under **Configuration** → **UNIT** → **CV.FN**, set **CV.FN** to 1 for continuous fan or 0 for automatic fan.
7. To program time schedules, set **SCH.N**=1 under **Configuration** → **CCN** → **SC.OV** → **SCH.N** to configure the control to use local schedules.
8. Under the **Timeclock** → **SCH.L** submenu, enter the desired schedule. See Time Clock Configuration section on page 76 for further description of these configurations.
9. See the Economizer Options section below for additional economizer option configurations.
10. See the Exhaust Options section on page 29 for additional exhaust option configurations.

**Economizer Options** — Under the **Configuration** → **ECON** submenu, the following set points may be configured:

**EC.EN** Economizer Enabled?  
**EC.MN** Economizer Min.Position  
**EC.MX** Economizer Maximum Position  
**E.TRM** Economizer Trim for SumZ?  
**E.SEL** Econ Changeover Select  
**OA.E.C** OA Enthalpy Change Over Select  
**OA.EN** Outdoor Enthalpy Compare Value  
**OAT.L** High OAT Lockout Temp  
**O.DEW** OA Dew Point Temp Limit  
**ORH.S** Outside Air RH Sensor

**Configuration** → **ECON** → **EC.MN** should always be set for the minimum damper position.



## Indoor Air Quality (IAQ) Options

DEMAND CONTROLLED VENTILATION — Under **Configuration**→**IAQ**→**DCV.C**, the following configuration parameters should be set to establish the minimum and maximum points for outdoor air damper position during demand controlled ventilation (DCV):

**EC.MN** Economizer Min.Position

**IAQ.M** IAQ Demand Vent Min.Pos.

**Configuration**→**IAQ**→**DCV.C**→**IAQ.M** is used to set the absolute minimum vent position (or maximum reset) under DCV.

**Configuration**→**IAQ**→**DCV.C**→**EC.MN** is used to set the minimum damper position (or with no DCV reset). This is also referenced in the economizer section.

**Exhaust Options** — The A Series units can be configured with constant volume 2-stage power exhaust or modulating power exhaust. The following exhaust options should be configured.

**Configuration**→**BP**→**BF.CF=1** (Two-Stage Exhaust Option) — For two-stage exhaust, under the **Configuration**→**BP** submenu, configure the following:

**BPP1** Power Exhaust On Setp.1

**BPP2** Power Exhaust On Setp.2

**Configuration**→**BP**→**BF.CF=2** (Modulating Power Exhaust Option) — For modulating exhaust, in the **Configuration**→**BP** submenu, configure the following:

**BP.SP** Building Pressure Setp.

**Programming Operating Schedules** — The *ComfortLink* controls will accommodate up to eight different schedules (Periods 1 through 8), and each schedule is assigned to the desired days of the week. Each schedule includes an occupied on and off time. As an example, to set an occupied schedule for 8 AM to 5 PM for Monday through Friday, the user would set days Monday through Friday to ON for Period 1. Then the user would configure the Period 1 Occupied From point to 08:00 and the Period 1 Occupied To point to 17:00. To create a different weekend schedule, the user would use Period 2 and set days Saturday and Sunday to ON with the desired Occupied On and Off times. To create a schedule, perform the following procedure:

NOTE: By default, the time schedule periods are programmed for 24 hours of occupied operation.

1. Scroll to the Configuration mode, and select CCN CONFIGURATION (**CCN**). Scroll down to the Schedule Number (**Configuration**→**CCN**→**SC.OV**→**SCH.N**). If password protection has been enabled, the user will be prompted to enter the password before any new data is accepted. **SCH.N** has a range of 0 to 99. The default value is 1. A value of 0 is always occupied, and the unit will control to its occupied set points. A value of 1 means the unit will follow a local schedule, and a value of 65 to 99 means it will follow a CCN schedule. Schedules 2 to 64 are not used as the control only supports one internal/local schedule. If one of the 2 to 64 schedules is configured, then the control will force the number back to 1. Make sure the value is set to 1 to use a local schedule.
2. Enter the Time Clock mode. Scroll down to the LOCAL TIME SCHEDULE (**SCH.L**) sub-mode, and press ENTER. Period 1 (**PER.1**) will be displayed. Press ENTER to configure Period 1.
3. Configure the beginning of the occupied time period for Period 1 (**OCC**). Scroll down to **OCC** and press ENTER to go into Edit mode. The first two digits of the 00.00 will start flashing. Use the UP or DOWN key to display the

correct value for hours, in 24-hour (military) time. Press ENTER and hour value is saved and the minutes digits will start flashing. Use the same procedure to display and save the desired minutes value. Press ESCAPE.

4. Configure the unoccupied time for period 1 (**UNC**). Scroll down to **UNC** and press ENTER to go into Edit mode. The first two digits of the 00.00 will start flashing. Use the UP or DOWN key to display the correct value for hours, in 24-hour (military) time. Press ENTER and hour value is saved and the minutes digits will start flashing. Use the same procedure to display and save the desired minutes value. Press ESCAPE.
5. Scroll to **DAYS** and press ENTER. Scroll down to the **MON** point. This point indicates if schedule 1 applies to Monday. Use the ENTER command to go into Edit mode, and use the UP or DOWN key to change the display to YES or NO. Scroll down through the rest of the days and apply schedule 1 where desired. The schedule can also be applied to a holiday. Press ESCAPE.
6. The first schedule is now complete. If a second schedule is needed, such as for weekends or holidays, scroll down and repeat the entire procedure for period 2 (**PER.2**). If additional schedules are needed, repeat the process for as many as are needed. Eight schedules are provided.

## SERVICE TEST

**General** — The units are equipped with a Service Test feature, which is intended to allow a service person to force the unit into different modes of operation to test them. To use this feature, enter the Service Test category on the local display and place the unit into the test mode by changing **Service Test**→**TEST** from OFF to ON. The display will prompt for the password before allowing any change. The default password is 1111. Once the unit enters the Service Test mode, the unit will shut down all current modes.

**TEST** — The **TEST** command turns the unit off (hard stop) and allows the unit to be put in a manual control mode.

**STOP** — The **STOP** command completely disables the unit (all outputs turn off immediately). Once in this mode, nothing can override the unit to turn it on. The controller will ignore all inputs and commands.

**S.STP** — Setting Soft Stop to YES turns the unit off in an orderly way, honoring any time guards currently in effect.

**FAN.F** — By turning the FAN FORCE on, the supply fan is turned on and will operate as it normally would, controlling duct static pressure on VAV applications or just energizing the fan on CV applications. To remove the force, press ENTER and then press the UP and DOWN arrows simultaneously.

**F4.CH** — The 4-Inch Filter Change Mode variable is used to service the unit when 4-in. filters are used. When the filters need to be changed, set **Service Test**→**F4.CH** = YES. The unit will be placed in Service Test mode and the economizer will move to the 40% open position to facilitate removal of the 4-in. filters. After the filters have been changed, set **Service Test**→**F4.CH** = NO to return the unit to normal operation.

The remaining categories: **INDP**, **FANS**, **COOL**, and **HEAT** are sub-modes with separate items and functions. See Table 41.

**Service Test Mode Logic** — Operation in the Service Test mode is sub-mode specific except for the Independent sub-mode. Leaving the sub-mode while a test is being performed and attempting to start a different test in the new sub-mode will cause the previous test to terminate. When this happens, the new request will be delayed for 5 seconds. For example, if compressors were turned on under the **COOL** sub-mode, any attempt to turn on heating stages within the **HEAT** sub-mode would immediately turn off the compressors and, 5 seconds later, the controller would honor the requested heat stages.

However, it is important to note that the user can leave a Service Test mode to view any of the local display modes and the control will remain in the Service Test mode.

**Independent Outputs** — The *INDP* sub-mode items can be turned on and off regardless of the other category states. For example, the alarm relay can be forced on in the *INDP* sub-mode and will remain on if compressor relays are requested in the *COOL* sub-mode.

**Fans in Service Test Mode** — Upon entering the *FANS* sub-mode, the user will be able to turn the supply fan on and off, set the supply fan VFD speed, and turn the condenser fans on and off.

**Cooling in Service Test Mode** — The *COOL* sub-mode offers different cooling service tests.

The user has manual relay control of individual compressors. If the user energizes mechanical cooling, the supply fan and the outdoor fans will be started automatically. During mechanical cooling, the unit will protect itself. Compressor diagnostics are active, monitoring for high discharge pressure, low suction pressure, etc. The user can also turn the hot gas bypass valve on and off.

NOTE: It is crucial that proper compressor rotation be verified during the service test. Each compressor must be tested

individually. After starting each compressor, the control will check the suction pressure after 5 seconds of run time. If the control does not see a sufficient decrease in suction pressure after 5 seconds, mechanical cooling will be shut down, and an alarm will be generated (A140). This alarm requires a manual reset. If this alarm occurs, do not attempt a restart of the compressor and do not attempt to start any other compressors until the wiring to the unit has been corrected.

**Heating in Service Test Mode** — If unit has a thermostat connected (*C.TYP* = 3 or 4), install the RED jumper wires between TB4, terminals R (1), W2 (3) and W1 (4). Terminal block TB4 is located in the unit control box. Remember to disconnect these jumpers when Test Mode is completed. The Heat Test Mode sub-mode will offer automatic fan start-up if the unit is not a gas heat unit. On gas heat units, the IGC feedback from the gas control units will bring the fan on as required.

Within this sub-mode, the user has control of heat relays 1 to 6. The user can also turn on the requested heat stage.

NOTE: When service test has been completed, if unit has a thermostat connected (*C.TYP* = 3 or 4), remove the RED jumper wires at TB4, terminals R (1), W2 (3) and W1 (4). Terminal block TB4 is located in the unit control box. Store these jumpers in the unit control box for future use.

**Table 41 — Service Test**

ITEM	EXPANSION	RANGE	UNITS	POINT	WRITE STATUS
<i>TEST</i> <i>STOP</i> <i>S.STP</i> <i>FAN.F</i> <i>F.4.CH</i>	Service Test Mode Local Machine Disable Soft Stop Request Supply Fan Request 4 in. Filter Change Mode	ON/OFF YES/NO YES/NO YES/NO YES/NO		MAN_CTRL UNITSTOP SOFTSTOP SFANFORC FLT4CHG	config forcible forcible
<i>INDP</i> <i>ECON</i> <i>E.PWR</i> <i>E.CAL</i> <i>E.VFD</i> <i>PE.A</i> <i>PE.B</i> <i>PE.C</i> <i>H.I.R</i> <i>ALRM</i>	TEST INDEPENDENT OUTPUTS Economizer Act.Cmd.Pos. Economizer Power Test Calibrate the Economizer? Exhaust Fan VFD Speed Power Exhaust Relay A Power Exhaust Relay B Power Exhaust Relay C Heat Interlock Relay Remote Alarm/Aux Relay	0-100       ON/OFF ON/OFF	%	ECONCTST ECONPTST ECON_CAL EFAN_VFD PE_A_TST PE_B_TST PE_C_TST HIR_TST ALRM_TST	
<i>FANS</i> <i>S.FAN</i> <i>S.VFD</i> <i>CD.FA</i> <i>CD.FB</i>	TEST FANS Supply Fan Relay Supply Fan VFD Speed Condenser Fan Circuit A Condenser Fan Circuit B	ON/OFF 0-100 ON/OFF ON/OFF	%	SFAN_TST SGVFDTST CNDA_TST CNDB_TST	
<i>COOL</i> <i>A1</i> <i>A2</i> <i>MLV</i> <i>B1</i> <i>B2</i>	TEST COOLING Compressor A1 Relay Compressor A2 Relay Min. Load Valve (HGBP) Compressor B1 Relay Compressor B2 Relay	ON/OFF ON/OFF ON/OFF ON/OFF ON/OFF		CMPA1TST CMPA2TST MLV_TST CMPB1TST CMPB2TST	
<i>HEAT</i> <i>HT.ST</i> <i>HT.1</i> <i>HT.2</i> <i>HT.3</i> <i>HT.4</i> <i>HT.5</i> <i>HT.6</i>	TEST HEATING Requested Heat Stage Heat Relay 1 Heat Relay 2 Relay 3 W1 Gas Valve 2 Relay 4 W2 Gas Valve 2 Relay 5 W1 Gas Valve 3 Relay 6 W2 Gas Valve 3	0-MAX ON/OFF ON/OFF ON/OFF ON/OFF ON/OFF ON/OFF		HTST_TST HS1_TST HS2_TST HS3_TST HS4_TST HS5_TST HS6_TST	

## THIRD PARTY CONTROL

**Thermostat** — The method of control would be through the thermostat inputs:

- Y1 = first stage cooling
- Y1 and Y2 = first and second stage cooling
- W1 = first stage heating
- W1 and W2 = first and second stage heating
- G = supply fan

**Alarm Output** — The alarm output TB4-7 and 8, will provide relay closure whenever the unit is under an alert or alarm condition.

**Remote Switch** — The remote switch may be configured for three different functions. Under *Configuration* → *UNIT*, set *RM.CF* to one of the following:

- 0 = no remote switch
- 1 = occupied/unoccupied switch
- 2 = start/stop switch
- 3 = occupancy override switch

With *RM.CF* set to 1, no time schedules are followed and the unit follows the remote switch only in determining the state of occupancy.

With *RM.CF* set to 2, the remote switch can be used to shut down and disable the unit, while still honoring time guards on compressors. Time schedules, internal or external, may be run simultaneously with this configuration.

With *RM.CF* set to 3, the remote input may override an unoccupied state and force the control to go into occupied mode. As with the start/stop configuration, an internal or external time schedule may continue to control occupancy when the switch is not in effect.

Under *Configuration* → *SW.LG* → *RM.I.L*, the remote occupancy switch can be set to either a normally open or normally closed switch input. Normal is defined as either unoccupied, start or “not currently overridden,” respective to the *RM.CF* configuration.

**VFD Control** — On VFD equipped supply fans, supply duct static pressure control may be left under unit control or be externally controlled. To control a VFD externally with a 4 to 20 mA signal, set *SPRS* to 4, under the *Configuration* → *SP* menu. This will set the reset to VFD control. When *SPRS* = 4, the static pressure reset function acts to provide direct VFD speed control where 4 mA = 0% speed and 20 mA = 100% (*SPMN* and *SPMX* will override). Note that *SPCF* must be set to 1 (VFD Control) prior to configuring *SPRS* = 4. Failure to do so could result in damage to ductwork due to overpressurization. In effect, this represents a speed control signal “pass through” under normal operating circumstances. The *ComfortLink* controller overrides the third party signal for critical operation situations, most notably smoke and fire control. Wire the input to the controls expansion module (CEM) using TB-11 and 12. An optional CEM board is required.

See Appendix C and the VFD literature supplied with the unit for VFD configurations and field wiring connections to the VFD.

**Supply Air Reset** — With the installation of the CEM, the *ComfortLink* controller is capable of accepting a 4 to 20 mA signal, to reset the supply-air temperature up to a maximum of 20 F. See VFD Control section above.

**Demand Limit Control** — The term “demand limit control” refers to the restriction of the machine’s mechanical cooling capacity to control the amount of power that a machine may use.

Demand limiting using mechanical control is possible via two means:

Two discrete inputs tied to demand limit set point percentages.

OR

A 4 to 20 mA input that can reduce or limit capacity linearly to a set point percentage.

In either case, it will be necessary to install a controls expansion module (CEM).

**DEMAND LIMIT DISCRETE INPUTS** — First, set *D.M.L.S* in *Configuration* → *DMD.L* to 1 (2 switches).

When *Inputs* → *GEN.I* → *DL.S1* (Demand Switch no. 1) is OFF, the control will not set any limit to the capacity, and when ON, the control sets a capacity limit to the *Configuration* → *DMD.L* → *D.L.S1* set point.

Likewise, when *Inputs* → *GEN.I* → *DL.S2* (Demand Switch no. 2) is OFF, the control will not set any limit to the capacity, and when ON, the control sets a capacity limit to the *Configuration* → *DMD.L* → *D.L.S2* set point.

If both switches are ON, *Inputs* → *GEN.I* → *DL.S2* is used as the limiter of capacity.

Under *Configuration* → *SW.LG* set the logic state appropriately for the action desired. Set the *DL1.L* and *DL2.L* configurations. They can be set normally open or normally closed. For example, if *DL1.L* is set to OPEN, the user will need to close the switch to cause the control to limit capacity to the demand limit 1 set point. Likewise, if *DL1.L* is set to CLSE (closed), the user will need to open the switch to cause the control to limit capacity to the demand limit 1 set point.

**DEMAND LIMIT 4 TO 20 mA INPUT** — Under *Configuration* → *DMD.L*, set configuration *D.M.L.S* to 2 (2 = 4 to 20 mA control). Under the same menu, set *D.L.20* to a value from 0 to 100% to set the demand limit range. For example, with *D.L.20* set to 50, a 4 mA signal will result in no limit to the capacity and 20 mA signal will result in a 50% reduction in capacity.

## Demand Controlled Ventilation Control —

There are multiple methods for externally controlling the economizer damper.

**IAQ DISCRETE INPUT CONFIGURATION** — The IAQ discrete input configuration requires a CEM module (optional) to be installed and an interface to a switch input at TB5-13 and 14. The state of the input on the display can be found at *Inputs* → *AIR.Q* → *IAQ.I*.

Before configuring the switch functionality, first determine how the switch will be read. A closed switch can indicate either a low IAQ condition or a high IAQ condition. This is set at *Configuration* → *SW.LG* and *IAQ.L*. The user can set what a low reading would mean based on the type of switch being used. Setting *IAQ.L* to OPEN means that when the switch is open the input will read LOW. When the switch is closed, the input will read HIGH. Setting *IAQ.L* to CLSE (closed) means that when the switch is closed the input will read LOW, and therefore, when the switch is open the switch will read HIGH.

There are two possible configurations for the IAQ discrete input. Select item *Configuration* → *IAQ* → *AQ.CF* → *IQ.I.C* and configure for either 1 (IAQ Discrete) or 2 (IAQ Discrete Override).

**IQ.I.C = 1 (IAQ Discrete)** — If the user sets *IQ.I.C* to 1 (IAQ Discrete), and the switch logic (*Configuration* → *SW.LG* → *IAQ.L*) is set to OPEN, then an open switch reads low and a closed switch reads high.

If the switch is open, the economizer will be commanded to the IAQ Demand Vent Minimum Position.

These settings may be adjusted and are located at *Configuration* → *IAQ* → *DCV.C* → *IAQ.M*.

If the switch is closed, the IAQ reading will be high and the economizer will be commanded to the Economizer Minimum Position.

This setting may be adjusted and is located at *Configuration* → *IAQ* → *DCV.C* → *EC.MN*.

***IQ.I.C = 2*** (IAQ Discrete Override) — If the user sets ***IQ.I.C*** to 2 (IAQ Discrete Override), and ***Configuration*** → ***SW.LG*** → ***IAQ.L*** is set to OPEN, then an open switch reads low and a closed switch reads high.

If the switch reads low, no action will be taken. If the switch reads high, the economizer will immediately be commanded to the IAQ Economizer Override Position. This can be set from 0 to 100% and can be found at ***Configuration*** → ***IAQ*** → ***AQ.SP*** → ***IQ.O.P***.

**FAN CONTROL FOR THE IAQ DISCRETE INPUT** — Under ***Configuration*** → ***IAQ*** → ***AQ.CF***, the ***IQ.I.F*** (IAQ Discrete Input Fan Configuration) must also be set. There are three configurations for ***IQ.I.F***. Select the configuration which will be used for fan operation. This configuration allows the user to decide (if the supply fan is not already running), whether the IAQ discrete switch will start the fan, and in which state of occupancy the fan will start.

- IQ.I.F = 0*** Minimum Position Override Switch input will not start fan
- IQ.I.F = 1*** Minimum Position Override Switch input will start fan in occupied mode only
- IQ.I.F = 2*** Minimum Position Override Switch input will start fan in both occupied and unoccupied modes

**IAQ ANALOG INPUT CONFIGURATION** — This input is an analog input located on the main base board (MBB). There are 4 different functions for this input. The location of this configuration is at ***Configuration*** → ***IAQ*** → ***AQ.CF*** → ***IQ.A.C***.

The functions possible for ***IQ.A.C*** are:

- 0 = no IAQ analog input
- 1 = IAQ analog input
- 2 = IAQ analog input used to override to a set position
- 3 = 4 to 20 mA 0 to 100% economizer minimum position control
- 4 = 0 to 10 kilo-ohms 0 to 100% economizer minimum position control

Options 2, 3, and 4 are dedicated for third party control.

***IQ.A.C = 2*** (IAQ Analog Input Used to Override) — Under ***Configuration*** → ***IAQ*** → ***AQ.SP***, set ***IQ.O.P*** (IAQ Economizer Override Position). The ***IQ.O.P*** configuration is adjustable from 0 to 100%. These configurations are also used in conjunction with ***Configuration*** → ***IAQ*** → ***AQ.CF*** → ***IQ.A.F*** (IAQ 4 to 20 mA Fan Configuration). There are three configurations for ***IQ.A.F*** and they follow the same logic as for the discrete input. This configuration allows the user to decide (if the supply fan is not already running), if the IAQ Analog Minimum Position Override input will start the fan, and in which state of occupancy the fan will start.

- IQ.A.F = 0*** IAQ analog sensor input cannot start the supply fan
- IQ.A.F = 1*** IAQ analog sensor input can start the supply fan in occupied mode only
- IQ.A.F = 2*** IAQ analog sensor input can start the supply fan in both occupied and unoccupied modes

If ***IQ.A.F*** is configured to request the supply fan, then configurations ***D.F.ON*** and ***D.F.OF*** need to be set. These configuration settings are located under ***Configuration*** → ***IAQ*** → ***AQ.SP*** and configure the fan override operation based on the differential air quality (DAQ). If DAQ rises above ***D.F.ON***, the control will request the fan on until DAQ falls below ***D.F.OF***.

NOTE: If ***D.F.ON*** is configured below ***DAQ.H***, the unit is in occupied mode, and the fan was off, then DAQ rose above ***D.F.ON*** and the fan came on, the economizer will go to the economizer minimum position (***EC.MN***).

The 4 to 20 mA signal from the sensor wired to TB5-6 and 7 is scaled to an equivalent indoor CO<sub>2</sub> (IAQ) by the parameters ***IQ.R.L*** and ***IQ.R.H*** located under the ***Configuration*** → ***IAQ*** → ***AQ.S.R*** menu. The parameters are defined such that 4 mA = ***IQ.R.L*** and 20 mA = ***IQ.R.H***. When the differential air quality DAQ (IAQ – ***OAQ.U***) exceeds the ***DAQ.H*** set point (***Configuration*** → ***IAQ*** → ***AQ.SP*** menu) and the supply fan is on, the economizer minimum vent position (***Configuration*** → ***IAQ*** → ***DCV.C*** → ***EC.MN***) is overridden and the damper is moved to the ***IQ.P.O*** configuration. When the DAQ falls below the ***DAQ.L*** set point (***Configuration*** → ***IAQ*** → ***AQ.SP*** menu), the economizer damper is moved back to the minimum vent position (***EC.MN***).

NOTE: Configuration ***OAQ.U*** is used in the calculation of the trip point for override and can be found under ***Configuration*** → ***IAQ*** → ***AQ.SP***.

***IQ.A.C = 3*** (4 to 20 mA Damper Control) — This configuration will provide full 4 to 20 mA remotely controlled analog input for economizer minimum damper position. The 4 to 20 mA signal is connected to terminals TB5-6 and 7. The input is processed as 4 mA = 0% and 20 mA = 100%, thereby giving complete range control of the effective minimum position.

The economizer sequences can be disabled by setting ***Configuration*** → ***ECON*** → ***E.SEL*** to 0. Complete control of the economizer damper position is then possible by using a 4 to 20 mA economizer minimum position control or a 0 to 10 kilo-ohm 0 to 100% economizer minimum position control via configuration decisions at ***Configuration*** → ***IAQ*** → ***AQ.CF*** → ***IQ.A.C***.

***IQ.A.C = 4*** (10 Kilo-ohm Potentiometer Damper Control)

— This configuration will provide input for a 10 kilo-ohm linear potentiometer that acts as a remotely controlled analog input for economizer minimum damper position. The input is processed as 0 ohms = 0% and 10,000 ohms = 100%, thereby giving complete range control of the effective minimum position.

## CONTROLS OPERATION

**Modes** — The *ComfortLink* controls operate under a hierarchy of command structure as defined by three essential elements: the System mode, the HVAC mode and the Control mode. The System mode is the top level mode that defines three essential states for the control system: OFF, RUN and TEST.

The HVAC mode is the functional level underneath the System mode which further defines the operation of the control. The mode selection process is shown in Appendix D.

The Control mode is essentially the control type of the unit (***Configuration*** → ***UNIT*** → ***C.TYP***). This defines from where the control looks to establish a cooling or heating mode and whether 2 stages or multiple stages of cooling capacity operation are controlled.

Furthermore, there are a number of modes which operate concurrently when the unit is running. The operating modes of the control are located at the local displays under ***Operating Modes***. See Table 42.

**Currently Occupied (OCC)** — This variable displays the current occupied state of the unit.

**Timed Override in Effect (T.OVR)** — This variable displays if the state of occupancy is currently occupied due to an override.

**DCV Resetting Minimum Position (DCV)** — This variable displays if the economizer position has been lowered from its maximum vent position.

**Table 42 — Operating Modes Display Table**

ITEM	EXPANSION	RANGE	CCN POINT
<b>SYS.M</b>	ascii string		n/a
<b>HVAC</b>	ascii string		n/a
<b>CTRL</b>	ascii string		n/a
<b>MODE</b>	MODES CONTROLLING UNIT		
<b>OCC</b>	Currently Occupied	ON/OFF	MODEOCCP
<b>T.OVR</b>	Timed Override in Effect	ON/OFF	MODETOVR
<b>DCV</b>	DCV Resetting Min Pos	ON/OFF	MODEADCV
<b>SA.R</b>	Supply Air Reset	ON/OFF	MODESARS
<b>DMD.L</b>	Demand Limit in Effect	ON/OFF	MODEDMLT
<b>T.C.ST</b>	Temp.Compensated Start	ON/OFF	MODETCST
<b>IAQ.P</b>	IAQ Pre-Occ Purge Active	ON/OFF	MODEIQPG
<b>LINK</b>	Linkage Active — CCN	ON/OFF	MODELINK
<b>LOCK</b>	Mech.Cooling Locked Out	ON/OFF	MODELOCK
<b>H.NUM</b>	HVAC Mode Numerical Form	number	MODEHVAC

**Supply Air Reset (SA.R)** — This variable displays if the supply air reset is currently active. This applies to cooling only.

**Demand Limit in Effect (DMD.L)** — This variable displays if the mechanical cooling capacity is currently being limited or reduced by an outside third party.

**Temperature Compensated Start (T.C.ST)** — This variable displays if Heating or Cooling has been initiated before the occupied period to pre-condition the space.

**IAQ Pre-Occupancy Purge Active (IAQ.P)** — This variable displays if the economizer is open and the fan is on to pre-ventilate the building before occupancy.

**Linkage Active CCN (LINK)** — This variable displays if a linkage master in a zoning system has established “linkage” with this air source (rooftop).

**Mechanical Cooling Locked Out (LOCK)** — This variable displays if mechanical cooling is currently being locked due to low outside air temperature.

**HVAC Mode Numerical Form (H.NUM)** — This is a numerical representation of the HVAC modes which may be read via a point read.

**SYSTEM MODES (Operating Modes → SYS.M)**

**System Mode Off** — When the system mode is OFF, all outputs are to be shut down and no machine control is possible. The following list displays the text assigned to the System Mode when in the OFF mode and the conditions that may cause this mode are checked in the following hierarchal order:

- Wake up timer on a power reset.  
 (“Initializing System ...”)
- System in the process of shutting down compressors and waiting for timeguards to expire.  
 (“Shutting Down ...”)
- Factory shut down (internal factory control level — SHUTDOWN).  
 (“Factory Shut Down”)
- Unit stop (software application level variable that acts as a hard shut down — **Service Test** → **STOP**).  
 (“Local Machine Stop”)
- Fire shut down (traumatic fire shutdown condition based on the Fire Shutdown Input — **Inputs** → **FIRE** → **FSD**).  
 (“Fire-Shutdown Mode”)
- Emergency stop, which is forced over the CCN through the Emergency Stop Variable (EMSTOP).  
 (“CCN Emergency Stop”)
- Startup delay.  
 (“Startup delay = 0-900 secs”)
- Service test ending transition timer.  
 (“Service Test Ending”)
- Unexplained internal software failure.  
 (“Internal Failure”)

**System Mode Test** — When the system mode is Test, the control is limited to the Test mode and is controllable via the local displays (scrolling marquee and Navigator™ display) or through the factory service test control. The System Test modes are Factory Test Enabled and Service Test Enabled. See the Service Test Mode section for details on test control in this mode.

- Factory Test mode  
 (“Factory test enabled”)
- Service Test mode  
 (“Service test enabled”)

**System Mode Run** — When the system mode is Run, the software application in the control is free to run the HVAC control routines by which cooling, heating, IAQ, etc., is possible. There are two possible text displays for this mode, one is normal run mode and the other occurs if one of the following fire-smoke modes is present: smoke purge, pressurization or evacuation.

- Normal run time state  
 (“Unit Operation Enabled”)
- Fire-Smoke control mode  
 (“Fire-Smoke Control”)

**HVAC MODES (Operating Mode → HVAC)** — The system mode must be selected before the unit controls can select the HVAC mode of the rooftop unit. The selection of an HVAC mode is based on a hierarchal decision making process. Certain overrides may interfere with this process and the normal temperature/humidity control operation of the unit. The decision making process that determines the HVAC mode is shown in Fig. 4 and Appendix D.

Each HVAC Mode is described below. The HVAC mode number is shown in parenthesis after the mode.

**HVAC Mode — STARTING UP (0)** — The unit is transitioning from the OFF mode to a different mode.

**HVAC Mode — DISABLED (1)** — The unit is shut down due to a software command disable through the scrolling marquee, a CCN emergency stop command, a service test end, or a control-type change delay.

**HVAC Mode — SHUTTING DOWN (2)** — The unit is transitioning from a mode to the OFF mode.

**HVAC Mode — SOFTSTOP REQUEST (3)** — The unit is off due to a soft stop request from the control.

**HVAC Mode — REM SW.DISABLE (4)** — The unit is off due to the remote switch.

**HVAC Mode — FAN STATUS FAIL (5)** — The unit is off due to failure of the fan status switch.

**HVAC Mode — STATIC PRESSURE FAIL (6)** — The unit is off due to failure of the static pressure sensor.

**HVAC Mode — COMP.STUCK ON (7)** — The unit is shut down because there is an indication that a compressor is running even though it has been commanded off.

**HVAC Mode — OFF (8)** — The unit is off and no operating modes are active.

**HVAC Mode — TEST (9)** — The unit is in the self test mode which is entered through the Service Test menu.

**HVAC Mode — TEMPERING VENT (10)** — The economizer is at minimum vent position but the supply-air temperature has dropped below the tempering vent set point. Staged gas heat is used to temper the ventilation air.

**HVAC Mode — TEMPERING LOCOOL (11)** — The economizer is at minimum vent position but the combination of the outside-air temperature and the economizer position has dropped the supply-air temperature below the tempering cool set point. Staged gas heat is used to temper the ventilation air.

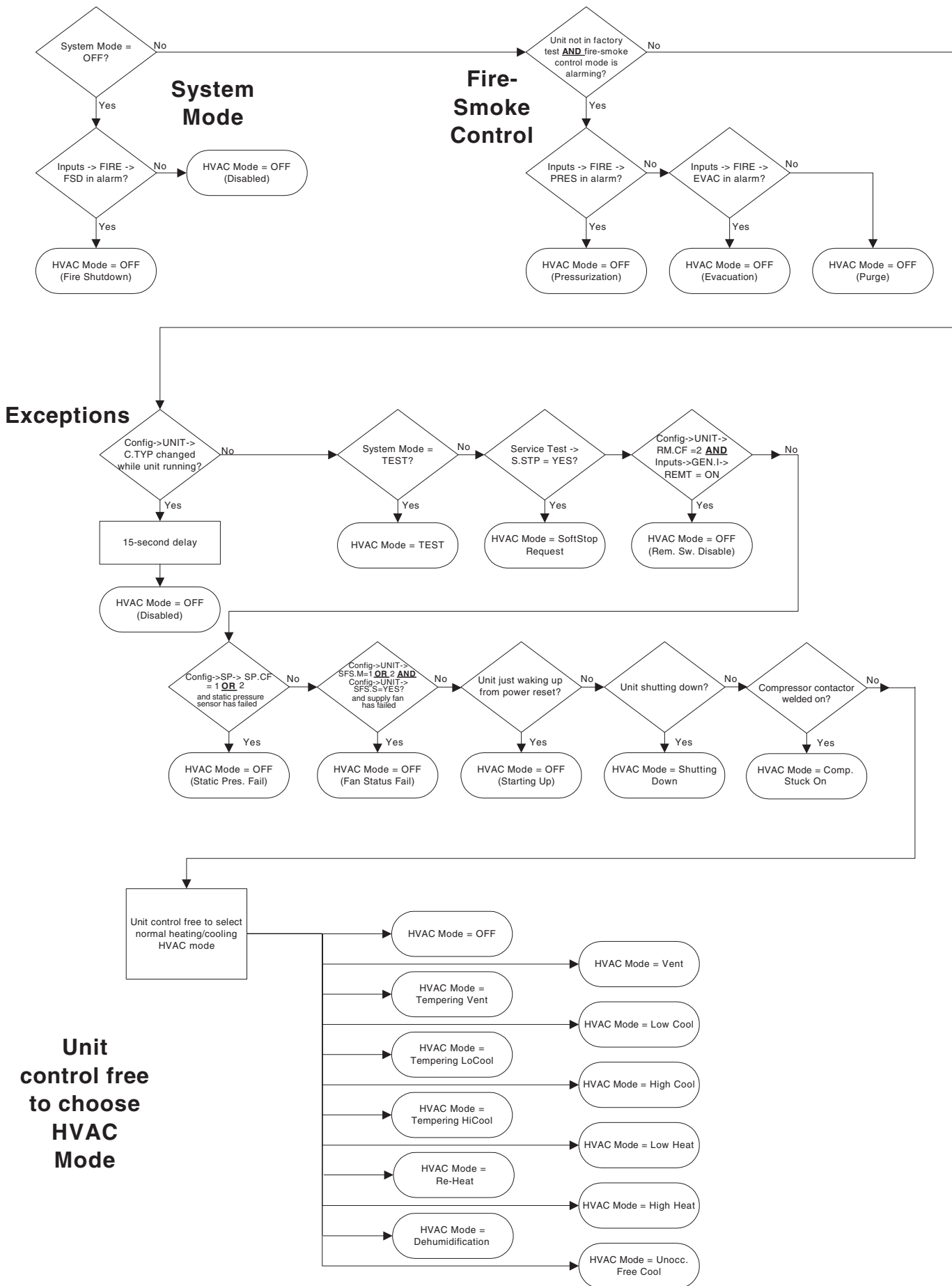


Fig. 4 — Mode Selection

**HVAC Mode — TEMPERING HICOOL (12)** — The economizer is at minimum vent position but the combination of the outside-air temperature and the economizer position has dropped the supply-air temperature below the tempering cool set point. Staged gas heat is used to temper the ventilation air.

**HVAC Mode — VENT (13)** — This is a normal operation mode where no heating or cooling is required and outside air is being delivered to the space to control IAQ levels.

**HVAC Mode — LOW COOL (14)** — This is a normal cooling mode where a low cooling demand is required.

**HVAC Mode — HIGH COOL (15)** — This is a normal cooling mode where a high cooling demand is required.

**HVAC Mode — LOW HEAT (16)** — The unit will be in low heating demand mode using either gas or electric heat.

**HVAC Mode — HIGH HEAT (17)** — The unit will be in high heating demand mode using either gas or electric heat.

**HVAC Mode — UNOCC. FREE COOL (18)** — In this mode the unit will operate in cooling but will be using the economizer for free cooling. Entering this mode will depend on the status of the outside air. The unit can be configured for outside air changeover, differential dry bulb changeover, outside air enthalpy changeover, differential enthalpy changeover, or a custom arrangement of enthalpy/dewpoint and dry bulb. See the Economizer section for further details.

**HVAC Mode — FIRE SHUT DOWN (19)** — The unit has been stopped due to a fire shutdown input (FSD) or two or more of the fire control modes, purge, evacuation, or pressurization have been requested simultaneously.

**HVAC Mode — PRESSURIZATION (20)** — The unit is in the special fire pressurization mode where the supply fan is on, the economizer damper is open and the power exhaust fans are off. This mode is started by the Fire Pressurization (**PRES**) input which can be found in the **INPUT→FIRE** sub-menu.

**HVAC Mode — EVACUATION (21)** — The unit is in the special Fire Evacuation mode where the supply fan is off, the economizer damper is closed and the power exhaust fans are on. This mode is started by the Fire Evacuation (**EVAC**) input which can be found in the **INPUT→FIRE** sub-menu.

**HVAC Mode — SMOKE PURGE (22)** — The unit is in the special Fire Purge mode where the supply fan is on, the economizer damper is open and the power exhaust fans are on. This mode is started by the Fire Evacuation (**PURG**) input which can be found in the **INPUT→FIRE** sub-menu.

**HVAC Mode — DEHUMIDIFICATION (23)** — The unit is operating in Dehumidification mode.

**HVAC Mode — REHEAT (24)** — The unit is operating in reheat mode.

**Unit Configuration Submenu** — The **UNIT** submenu under the Configuration mode of the local display contains general unit configuration items. The sub-menu which contains these configurations is located at the local display under **Configuration→UNIT**. See Table 43.

**Machine Control Type (C.TYP)** — This configuration defines the control type and control source responsible for selecting a cooling, heating, or vent mode and in determining the method by which compressors are staged. The control types are:

- **C.TYP = 1** (VAV-RAT) and **C.TYP = 2** (VAV-SPT)

Both of these configurations refer to standard VAV operation. If the control is occupied, the supply fan is run continuously and return-air temperature will be used in the determination of the selection of a cooling mode. VAV-SPT differs from VAV-RAT only in that during the unoccupied period, space temperature will be used instead of return-air temperature to start the fan for 10 minutes to establish an

accurate return-air temperature before the return-air temperature is allowed to call out any mode.

- **C.TYP = 3** (TSTAT-MULTI)

This configuration will force the control to monitor the thermostat inputs to make a determination of mode. Unlike traditional 2-stage thermostat control, the unit is allowed to use multiple stages of cooling control and perform VAV-type operation. The control will be able to call out a LOW COOL or a HIGH COOL mode and maintain a low or high cool supply air set point.

- **C.TYP = 4** (TSTAT-2 STG)

This configuration will force the control to monitor the thermostat inputs to make a determination of mode and allow only 2 stages of control for both heating and cooling.

- **C.TYP = 5** (SPT-MULTI)

This configuration will force the control to monitor a space temperature sensor to make a determination of mode. Unlike traditional 2-stage space temperature control, the unit is allowed to use multiple stages of cooling control and perform VAV-type operation. The control will be able to call out a LOW COOL or a HIGH COOL mode and maintain a low or high cool supply air set point.

- **C.TYP = 6** (SPT-2 STG)

This configuration will force the control to monitor the space temperature sensor to make a determination of mode and allow 2 stages of control for both heating and cooling.

**FAN MODE (CV.FN)** — The Fan Mode configuration can be used for machine control types (**Configuration→UNIT→C.TYP**) 3, 4, 5, and 6. The Fan Mode variable establishes the operating sequence for the supply fan during occupied periods. When set to 1 (Continuous), the fan will operate continuously during occupied periods. When set to 0 (Automatic), the fan will run only during a heating or cooling mode.

**REMOTE SWITCH CONFIG (RM.CF)** — The remote switch input is connected to TB6 terminals 1 and 3. This switch can be used for several remote control functions. Please refer to the Remote Control Switch Input section for details on its use and operation.

**CEM MODEL INSTALLED (CEM)** — This configuration instructs the control to communicate with the controls expansion module (CEM) over the Local Equipment Network (LEN) when set to Yes. When the unit is configured for certain sensors and configurations, this option will be set to Yes automatically.

The sensors and configurations that automatically turn on this board are:

**Configuration→UNIT→SFS.M = 1** (Supply Fan Status Switch Monitoring)

**Configuration→EDTR→RES.S = Enable** (4 to 20 mA Supply Air Reset Sensor Enable)

**Configuration→DMD.L→DM.L.S = 1** (2 SWITCHES) (Demand Limiting using 2 discrete switches)

**Configuration→DMD.L→DM.L.S = 2** (4-20 MA CTRL) (Demand Limiting using a 4 to 20 mA sensor)

**Configuration→IAQ→AQ.CF→IQ.I.C = 1** (IAQ DISCRETE) (IAQ discrete switch control)

**Configuration→IAQ→AQ.CF→IQ.I.C = 2** (IAQ DISC.OVR) (IAQ discrete switch “override” control)

**Configuration→IAQ→AQ.CF→OQ.A.C = 1** (OAQ SENS-DAQ) (Outdoor Air Quality Sensor)

**Configuration→IAQ→AQ.CF→OQ.A.C = 2** (4-20 NO DAQ) (4 to 20 mA sensor, no DAQ)

**Temperature Compensated Start Cooling Factor (TCS.C)** — This factor is used in the equation of the Temperature Compensated Start Time Bias for cooling. Refer to the Temperature

Compensated Start section for more information. A setting of 0 minutes indicates Temperature Compensated Start in Cooling is not permitted.

**Temperature Compensated Start Heating Factor (TCS.H)** — This factor is used in the equation of the Temperature Compensated Start Time Bias for heating. Refer to the Temperature Compensated Start section for more information. A setting of 0 minutes indicates Temperature Compensated Start in Heating is not permitted.

**Fan Fail Shuts Downs Unit (SFS.S)** — This configuration will determine whether the unit should shut down on a supply fan status fail or simply alert the condition and continue to run. If set to YES, then the control will shut down the unit and send out an alarm if supply fan status monitoring fails. If set to NO, the control will not shut down the unit if supply fan status monitoring fails but the control will send out an alert.

**Fan Status Monitoring (SFS.M)** — This configuration selects the type of fan status monitoring to be performed.

0 - NONE — No switch or monitoring

1 - SWITCH — Use of the fan status switch

2 - SP RISE — Monitoring of the supply duct pressure.

**VAV Unoccupied Fan Retry Time (VAV.S)** — Machine control types 1 and 2 (VAV-RAT,VAV-SPT) monitor the return-air temperature during unoccupied periods to determine if there is a valid demand for heating or cooling before initiating an unoccupied heating or cooling mode. If the routine runs but concludes a valid demand condition does not exist, then the process is not permitted for the period of time defined by this configuration. Reducing this value allows a more frequent re-sampling process. Setting this value to zero will prevent any sampling sequence.

**Unit Size (SIZE)** — There are several unit sizes (tons) for the A Series control. Make sure this configuration matches the size called out by the model number of the unit. This is important as the cooling stage tables are directly determined based on this configuration.

**Discharge Pressure Transducers (DP.XR)** — This configuration configures the unit for use with discharge pressure transducers. The 48/50A2,A3,A4,A5 units will be automatically configured for discharge pressure transducers and **DP.XR** should be set to Yes.

**Suction Pressure Transducer Type (SP.XR)** — This configuration specifies the type of suction pressure transducer that is being used. Set **SP.XR** to 0 for support of a pressure transducer with a range of 0 to 135 psig. Set **SP.XR** to 1 for support of a pressure transducer with a range of 0 to 200 psig.

NOTE: The 48/50A2,A3,A4,A5 units do not require a change to the **SP.XR** factory default setting.

**Refrigerant Type (RFG.T)** — This configuration specifies the type of refrigerant used in the unit. Configuration **RFG.T** is set to 0 if the refrigerant used is R-22. Configuration **RFG.T** is set to 1 if the refrigerant used is R-410A. Do not change this setting.

**Condenser Type (CND.T)** — This configuration specifies the type of condenser installed in the unit. Configuration **CND.T** is set to 0 if the condenser is a round tube, plate fin coil (RTPF). Configuration **CND.T** is set to 1 if the condenser is a micro-channel heat exchanger coil (MCHX).

**MAT Calc Config (MATS)** — This configuration gives the user three options in the processing of the mixed-air temperature (MAT) calculation:

- **MATS** = 0

There will be no MAT calculation.

- **MATS** = 1

The control will attempt to learn MAT over time. Any time the system is in a vent mode and the economizer stays at a particular position for long enough, MAT is set to equal EDT. Using this, the control has an internal table whereby it can more closely determine the true MAT value.

- **MATS** = 2

The control will not attempt to learn MAT over time.

To calculate MAT linearly, the user should reset the MAT table entries by setting **MAT.R** to YES. Then set **MATS** = 2. The control will calculate MAT based on the position of the economizer, outside-air temperature, and return-air temperature.

To freeze the MAT table entries, let the unit run with **MATS** = 1. Once sufficient data has been collected, change **MATS** = 2. Do not reset the MAT table.

**Table 43 — Unit Configuration**

ITEM	EXPANSION	RANGE	UNITS	CCN POINT	DEFAULTS
<b>UNIT</b>	UNIT CONFIGURATION				
<b>C.TYP</b>	Machine Control Type	1 - 6		CTRLTYPE	4
<b>CV.FN</b>	Fan Mode (0=Auto, 1=Cont)	0 - 1		FAN_MODE	1
<b>RM.CF</b>	Remote Switch Config	0 - 3		RMTINCFG	0
<b>CEM</b>	CEM Module Installed	Yes/No		CEM_BRD	No
<b>TCS.C</b>	Temp.Cmp.Strt.Cool Factr	0 - 60	min	TCSTCOOL	0
<b>TCS.H</b>	Temp.Cmp.Strt.Heat Factr	0 - 60	min	TCSTHEAT	0
<b>SFS.S</b>	Fan Fail Shuts Down Unit	Yes/No		SFS_SHUT	No
<b>SFS.M</b>	Fan Stat Monitoring Type	0 - 2		SFS_MON	0
<b>VAV.S</b>	VAV Unocc.Fan Retry Time	0 - 720	min	SAMPMINS	50
<b>SIZE</b>	Unit Size (20-60)	20 - 60		UNITSIZE	20
<b>DP.XR</b>	Discharge Press. Transducers	Yes/No		DP_TRANS	No
<b>SP.XR</b>	Suct. Pres. Trans. Type	0 - 1		SPXRTYPE	0
<b>RFG.T</b>	REFRIG: 0=R22, 1=R410A	0 - 1		REFRIG_T	Unit dependent
<b>CND.T</b>	CND HX TYP: 0=RTPF, 1=MCHX	0 - 1		COILTYPE	Unit dependent
<b>MATS</b>	MAT Calc Config	0 - 2		MAT_SEL	1
<b>MAT.R</b>	Reset MAT Table Entries?	Yes/No		MATRESET	No
<b>MAT.D</b>	MAT Outside Air Default	0-100	%	MATOADOS	20
<b>ALTI</b>	Altitude.....in feet:	0 - 60000		ALTITUDE	0
<b>DLAY</b>	Startup Delay Time	0 - 900	sec	DELAY	0
<b>STAT</b>	TSTAT-Both Heat and Cool	Yes/No		TSTATALL	No
<b>AUX.R</b>	Auxiliary Relay Config	0 - 3		AUXRELAY	0
<b>SENS</b>	INPUT SENSOR CONFIG				
<b>SPT.S</b>	Space Temp Sensor	Enable/Disable		SPTSENS	Disable
<b>SPO.S</b>	Space Temp Offset Sensor	Enable/Disable		SPTOSENS	Disable
<b>SP.O.R</b>	Space Temp Offset Range	1 - 10		SPTO_RNG	5
<b>RRH.S</b>	Return Air RH Sensor	Enable/Disable		RARHSENS	Disable
<b>FLT.S</b>	Filter Stat.Sw.Enabled ?	Enable/Disable		FLTS_ENA	Disable



**Reset MAT Table Entries? (MATR)** — This configuration allows the user to reset the internally stored MAT learned configuration data back to the default values. The defaults are set to a linear relationship between the economizer damper position and OAT and RAT in the calculation of MAT.

**MAT Outside Air Position Default (MATD)** — This configuration is used to calculate MAT when the economizer option is disabled. The configuration is adjustable from 0 to 100% outside air. This defines the fixed ventilation position that will be used to correctly calculate MAT.

**Altitude.....In Feet: (ALTI)** — The control does not include a barometric pressure sensor to determine altitude. The altitude must be defined the calculation of enthalpy and cfm. The altitude parameter is used to set up a default barometric pressure for use with calculations. The effect of barometric pressure in these calculations is not great, but could have an effect depending on the installed elevation of the unit. If the unit is installed at a particularly high altitude and enthalpy or cfm are being calculated, set this configuration to the current elevation.

**Start Up Delay Time (DLAY)** — This option delays the unit from operating after a power reset. The configuration may be adjusted from 0 to 900 seconds of delay.

**TSTAT — Both Heat and Cool (STAT)** — This option, if enabled, allows both heating and cooling requests to be made at the same time. If the unit is configured for staged gas heat, and if a cooling request is initiated (Y1 or Y2), then W1 initiates re-heat and W2 initiates dehumidification.

**Auxiliary Relay Configuration (AUX.R)** — This option configures the auxiliary relay on the MBB (RLY11). The function of this relay is configurable in the following ways:

- **AUX.R = 0** (Alarm Output) — The relay is used for remote annunciation of an alarm state.
- **AUX.R = 1** (Dehum-Reheat) — The relay is used as a dehumidification/reheat output.
- **AUX.R = 2** (Occup. State) — The relay is used to reflect occupancy. When the control is in occupied mode, the relay will be ON. When the control is in unoccupied mode, the relay will be OFF.
- **AUX.R = 3** (S. Fan State) — The relay is used to reflect the supply fan commanded state. When the supply fan is on, the relay will be ON. When the supply fan is off, the relay will be OFF.

**Space Temp Sensor (SPTS)** — If a space temperature sensor is installed, this configuration should be enabled.

**Space Temp Offset Sensor (SPOS)** — If a space temperature sensor with a space temperature offset slider is installed (T56), this configuration should be enabled.

**Space Temp Offset Range (SPO.R)** — If a space temperature offset sensor is installed, it is possible to configure the range of the slider by adjusting this range configuration.

**Return RH Sensor (RRH.S)** — If a return air relative humidity sensor is installed, this configuration should be enabled.

**Filter Status Switch Enabled? (FLTS)** — If a filter status switch is installed, enable this configuration to begin the monitoring of the filter status input (**Inputs** → **GEN.I** → **FLTS**). See the Dirty Filter Switch section for more details on installation and operation.

**Cooling Control** — When mechanical cooling is required, the A Series *ComfortLink* control system has the capability to control the staging of the compressors in several different ways. Three scroll compressors are used on sizes 020 to 027 and four on sizes 030 to 060. In addition, the *ComfortLink* control system supports the use of an optional minimum load hot gas bypass valve (MLV) that is directly controlled by the *ComfortLink* control system. This provides an additional stage of capacity as well as low load coil freeze protection. The control also integrates the use of an economizer with the use of

mechanical cooling to allow for the greatest use of free cooling. When both mechanical cooling and the economizer are being used, the control will use the economizer to provide better temperature control and limit the cycling of the compressors. The control also checks on various other operation parameters in the unit to make sure that safeties are not exceeded and the compressors are reliably operated.

The A Series *ComfortLink* control system offers two basic control approaches to mechanical cooling. Constant volume operation for 2 stages of cooling or VAV operation for multiple stages of cooling. In addition to these methods of control, the A Series *ComfortLink* control offers the ability to run multiple stages of cooling for either a space temperature sensor or thermostat by controlling the unit to either a low or high cool supply air set point. The control type **Configuration** → **UNIT** → **C.TYP** determines the selection of the type of cooling control as well as the method for selecting a cooling mode.

There are either three or four compressors divided among two refrigeration circuits in the unit. Circuit A always contains two compressors (A1,A2). Circuit B has either one or two compressors (B1,B2). There may be a minimum load valve (MLV), which, if present, is only associated with circuit A. The decision as to which compressor should be turned on or off is decided by the compressor's availability followed by a preferred staging order.

NOTE: Configuration of the machine control type (**C.TYP**) has no effect on whether a unit has a VFD or just a supply fan installed for static pressure control. No matter what the control type is, it is possible to run the unit in either CV or VAV mode provided there are enough stages to accommodate lower air volumes for VAV operation. Refer to the section on static pressure control for information on how to set up the unit for the type of supply fan control desired.

#### SETTING UP THE SYSTEM

**Machine Control Type (Configuration → UNIT → C.TYP)** — The most important cooling control configuration is located under **Configuration** → **UNIT**.

This configuration defines the method and control source responsible for selecting a cooling mode. The configuration also determines the method by which compressors are staged. Control types are:

- **C.TYP = 1** (VAV-RAT) and **C.TYP = 2** (VAV-SPT)

Both of these configurations refer to standard VAV operation. If the control is occupied, the supply fan is run continuously and return-air temperature will be used for both in the determination of the selection of a cooling mode. VAV-SPT differs from VAV-RAT only in that during the unoccupied period, space temperature will be used instead of return-air temperature to start the fan for ten minutes before the return-air temperature is allowed to call out any mode.

- **C.TYP = 3** (TSTAT-MULTI)

This configuration will force the control to monitor the thermostat inputs to make a determination of mode. Unlike traditional 2-stage thermostat control, the unit is allowed to use multiple stages of cooling control and perform VAV style operation. The control will be able to call out a LOW COOL or a HIGH COOL mode and maintain a low or high cool supply air set point.

- **C.TYP = 4** (TSTAT-2 STG)

This configuration will force the control to monitor the thermostat inputs to make a determination of mode.

- **C.TYP = 5** (SPT-MULTI)

This configuration will force the control to monitor a space temperature sensor to make a determination of mode. Unlike traditional 2-stage space temperature control, the unit is allowed to use multiple stages of cooling control and perform VAV style operation. The control will be able to call

out a LOW COOL or a HIGH COOL mode and maintain a low or high cool supply air set point.

- **C.TYP = 6** (SPT-2 STG)

This configuration will force the control to monitor the space temperature sensor to make a determination of mode and allow two stages of cooling.

**MACHINE DEPENDENT CONFIGURATIONS** — Some configurations are linked to the physical unit and must not be changed. The configurations are provided in case a field replacement of a board occurs and the settings are not preserved by the download process of the new software. The following configurations apply to all machine control types (**C.TYP**) except 4 and 6. These configurations are located at the local display under **Configuration**→**UNIT**. See Table 44.

**Table 44 — Machine Dependent Configurations**

ITEM	EXPANSION	RANGE	CCN POINT	DEFAULTS
<b>UNIT</b>	UNIT CONFIGURATION			
<b>SIZE</b>	Unit Size (20-60)	20-60	UNITSIZE	*
<b>RFG.T</b>	REFRIG	0-1	REFRIG_T	*
<b>CND.T</b>	CND HX TYP	0-1	COILTYPE	*

\*Dependent on unit.

**Unit Size (SIZE)** — There are several unit sizes (tons) for the A Series control. Make sure this configuration matches the size called out by the model number of the unit. This is important as the cooling stage tables are directly determined based on this configuration.

**Refrigerant Type (RFGT)** — This configuration specifies the type of refrigerant used in the unit. Configuration **RFGT** is set to 0 if the refrigerant used is R-22. Configuration **RFGT** is set to 1 if the refrigerant used is R-410A. Make sure this configuration matches the refrigerant called out by the model number of the unit.

**Condenser Type (CND.T)** — This configuration specifies the type of condenser installed in the unit. Configuration **CND.T** is set to 0 if the condenser is a round tube, plate fin coil (RTPF). Configuration **CND.T** is set to 1 if the condenser is a micro-channel heat exchanger coil (MCHX). Make sure this configuration matches the condenser type called out by the model number of the unit.

**SET POINTS** — The set points for both cooling and heating are located at the local display under **Setpoints**. See Table 45.

**Table 45 — Setpoints**

ITEM	EXPANSION	RANGE	UNITS	CCN POINT	DEFAULT
<b>OHSP</b>	Occupied Heat Setpoint	40-99	dF	OHSP	68
<b>OCSP</b>	Occupied Cool Setpoint	40-99	dF	OCSP	75
<b>UHSP</b>	Unoccupied Heat Setpoint	40-99	dF	UHSP	55
<b>UCSP</b>	Unoccupied Cool Setpoint	40-99	dF	UCSP	90
<b>GAP</b>	Heat-Cool Setpoint Gap	2-10	^F	HCSP_GAP	5
<b>V.C.ON</b>	VAV Occ. Cool On Delta	0-25	^F	VAVOCON	3.5
<b>V.C.OF</b>	VAV Occ. Cool Off Delta	1-25	^F	VAVOCOFF	2
<b>SASP</b>	Supply Air Setpoint	45-75	dF	SASP	55
<b>SA.HI</b>	Supply Air Setpoint Hi	45-75	dF	SASP_HI	55
<b>SA.LO</b>	Supply Air Setpoint Lo	45-75	dF	SASP_LO	60
<b>SA.HT</b>	Heating Supply Air Setpt	90-145	dF	SASPHEAT	85
<b>T.PRG</b>	Tempering Purge SASP	-20-80	dF	TEMPPURG	50
<b>T.CL</b>	Tempering in Cool SASP	5-75	dF	TEMPCOOL	5
<b>T.V.OC</b>	Tempering Vent Occ SASP	-20-80	dF	TEMPVOCC	65
<b>T.V.UN</b>	Tempering Vent Unocc. SASP	-20-80	dF	TEMPVUNC	50

**Table 46 — Supply Air Reset Configuration**

ITEM	EXPANSION	RANGE	UNITS	CCN POINT	DEFAULT
<b>EDT.R</b>	EVAP.DISCHRG TEMP RESET				
<b>RS.CF</b>	EDT Reset Configuration	0 - 3		EDRSTCFG	0
<b>RTIO</b>	Reset Ratio	0 - 10		RTIO	2
<b>LIMIT</b>	Reset Limit	0 - 20	^F	LIMIT	10
<b>RES.S</b>	EDT 4-20 ma Reset Input	Enable/Disable		EDTRSENS	Disable

**SUPPLY AIR RESET CONFIGURATION** — Supply Air Reset can be used to modify the current cooling supply air set point. Supply Air Reset is applicable to control types, **C.TYP** = 1,2,3, and 5. The configurations for reset can be found at the local display under **Configuration**→**EDT.R**. See Table 46.

**EDT Reset Configuration (RS.CF)** — This configuration applies to several machine control types (**Configuration**→**UNIT**→**C.TYP** = 1,2,3, and 5).

- 0 = NO RESET

No supply air reset is in effect

- 1 = SPT RESET

Space temperature will be used as the reset control variable along with both **RTIO** and **LIMIT** in the calculation of the final amount of reset to be applied (**Inputs**→**RSET**→**SA.S.R**).

- 2 = RAT RESET

Return-air temperature will be used as the reset control variable along with both **RTIO** and **LIMIT** in the calculation of the final amount of reset to be applied (**Inputs**→**RSET**→**SA.S.R**).

- 3 = 3RD PARTY RESET

The reset value is determined by a 4 to 20 mA third party input. An input of 4 mA would correspond to 0° F reset. An input of 20 mA would correspond to 20° F reset. Configuring the control for this option will cause **RES.S** to become enabled automatically with the CEM board. To avoid alarms make sure the CEM board and third party input are connected first before enabling this option.

**Reset Ratio (RTIO)** — This configuration is used when **RS.CF** is set to 1 or 2. For every degree that the controlling temperature (space/return) falls below the occupied cooling set point (**OCSP**), the calculated value of the supply air reset will rise by the number of degrees as specified by this parameter.

**Reset Limit (LIMIT)** — This configuration is used when **RS.CF** is set to 1 or 2. This configuration places a clamp on the amount of supply air reset that can be applied.

**EDT 4-20 mA Reset Input (RES.S)** — This configuration is automatically enabled when **Configuration**→**EDT.R**→**RS.CF** is set to 3 (third party reset).

**COOLING CONFIGURATION** — Relevant configurations for mechanical cooling are located at the local display under **Configuration**→**COOL**. See Table 47.

**Table 47 — Cooling Configuration**

ITEM	EXPANSION	RANGE	UNITS	CCN POINT	DEFAULT
<b>COOL</b>	COOLING CONFIGURATION				
<b>Z.GN</b>	Capacity Threshold Adjst	-10 - 10		Z_GAIN	1
<b>MC.LO</b>	Compressor Lockout Temp	-20 - 55	dF	OATLCOMP	40
<b>C.FOD</b>	Fan-Off Delay, Mech Cool	0-600	sec	COOL_FOD	60
<b>MLV</b>	Min. Load Valve (HGBP)?	Yes/No		MLV_SEL	No
<b>M.M.</b>	Motor Master Control ?	Yes/No		MOTRMAST	No
<b>HPSP</b>	Head Pressure Setpoint	80 - 150	dF	HPSP	113
<b>A1.EN</b>	Enable Compressor A1	Enable/Disable		CMPA1ENA	Enable
<b>A2.EN</b>	Enable Compressor A2	Enable/Disable		CMPA2ENA	Enable
<b>B1.EN</b>	Enable Compressor B1	Enable/Disable		CMPB1ENA	Enable
<b>B2.EN</b>	Enable Compressor B2	Enable/Disable		CMPB2ENA	Enable
<b>CS.A1</b>	CSB A1 Feedback Alarm	Enable/Disable		CSB_A1EN	Enable
<b>CS.A2</b>	CSB A2 Feedback Alarm	Enable/Disable		CSB_A2EN	Enable
<b>CS.B1</b>	CSB B1 Feedback Alarm	Enable/Disable		CSB_B1EN	Enable
<b>CS.B2</b>	CSB B2 Feedback Alarm	Enable/Disable		CSB_B2EN	Enable
<b>REV.R</b>	Rev. Rotation Verified?	Yes/No		REVR_VER	No
<b>H.SST</b>	Hi SST Alert Delay Time	5 - 30	min	HSSTTIME	10 (48/50AJ,AK,AW,AY) 20 (48/50A2,A3,A4,A5)

**Capacity Threshold Adjust (Z.GN)** — This configuration is used for units using the “SumZ” algorithm for cooling capacity control (*Configuration* → *UNIT* → *C.TYP* = 1, 2, 3 or 5). The configuration affects the cycling rate of the cooling stages by raising or lowering the threshold that demand must rise above in order to add or subtract a stage of cooling.

Normally this configuration should not require any tuning or adjustment. If there is an application where the unit may be significantly oversized and there are indications of high compressor cycles, then the Capacity Threshold Adjust (**Z.GN**) can be used to adjust the overall logic gain. Normally this is set to 1.0, but it can be adjusted from 0.5 to 4.0. As the value of **Z.GN** is increased, the cycling of cooling stages will be slowed.

**Compressor Lockout Temperature (MC.LO)** — This configuration is the outdoor air temperature setting below which mechanical cooling is locked out.

**Fan-Off Delay, Mech Cool (C.FOD)** — After a mechanical cooling cycle has ended, this is the delay in seconds that the supply fan will continue to operate.

**Min. Load Valve (HGBP)? (MLV)** — This configuration instructs the control as to whether a minimum load valve has been installed and will be controlled by the compressor staging routine.

**MotorMaster Control? (M.M.)** — The condenser fan staging control for the unit is managed directly by the *ComfortLink* controls. There is no physical Motormaster® device in the standard unit. The standard unit is capable of mechanical cooling operation down to 32 F outdoor temperature. With the addition of accessory Motormaster V speed control on the stage 1 condenser fan(s), mechanical cooling operation down to -20 F outdoor temperature is possible. The accessory Motormaster V speed control is a completely self-contained device and is not managed by the unit’s *ComfortLink* controller. The Motormaster control configuration (**M.M.**) only applies to the 060 size RTPF units. On 060 size RTPF units with accessory Motormaster V speed control installed, this configuration must be set to YES. See Head Pressure Control section, page 49, for more information.

**Head Pressure Set Point (HPSP)** — This is the head pressure set point used by the *ComfortLink* control during condenser fan, head pressure control.

**Enable Compressor A1 (A1.EN)** — This configuration is used to disable the A1 compressor in case of failure.

**Enable Compressor A2 (A2.EN)** — This configuration is used to disable the A2 compressor in case of failure.

**Enable Compressor B1 (B1.EN)** — This configuration is used to disable the B1 compressor in case of failure.

**Enable Compressor B2 (B2.EN)** — This configuration is used to disable the B2 compressor in case of failure.

**CSB A1 Feedback Alarm (CS.A1)** — This configuration is used to enable or disable the compressor A1 feedback alarm. This configuration must be enabled at all times.

**CSB A2 Feedback Alarm (CS.A2)** — This configuration is used to enable or disable the compressor A2 feedback alarm. This configuration must be enabled at all times.

**CSB B1 Feedback Alarm (CS.B1)** — This configuration is used to enable or disable the compressor B1 feedback alarm. This configuration must be enabled at all times.

**CSB B2 Feedback Alarm (CS.B2)** — This configuration is used to enable or disable the compressor B2 feedback alarm. This configuration must be enabled at all times.

**Reverse Rotation Verified? (REV.R)** — If this configuration is set to NO, then after a power up, in the normal run mode, the control will check the suction pressure on the first circuit that is energized after 5 seconds of run time. If the control does not see a sufficient decrease in suction pressure over the first 5 seconds, mechanical cooling will be shut down, and an alarm will be generated (A140). This alarm requires a manual reset.

If the unit is in the Service Test mode, the test will be performed any time a compressor is energized.

Once it has been verified that power to the rooftop and compressors has been applied correctly and the compressors start up normally, this configuration can be set to YES in order to prevent the reverse rotation check from occurring.

**High SST Alert Delay Time (H.SST)** — This option allows the high saturated suction temperature alert timing delay to be adjusted.

**COMPRESSOR SAFETIES** — The 48/50A Series units with *ComfortLink* controls include a compressor protection board (CSB) that protects the operation of each of the compressors. These boards sense the presence or absence of current to each compressor.

If there is a command for a compressor to run and there is no current, then one of the following safeties or conditions have turned the compressor off:

- Compressor overcurrent — Smaller compressors have internal line breaks and larger compressors have a dedicated circuit breaker for overcurrent protection.
- Compressor short circuit — the compressor circuit breaker that provides short circuit protection has tripped then there will not be current.
- Compressor motor over temperature — the internal line-break or over temperature switch has opened.
- High-pressure switch trip — High-pressure switch has opened.

Alarms will also occur if the current sensor board malfunctions or is not properly connected to its assigned digital input. If the compressor is commanded OFF and the Current Sensor reads ON, an alert is generated. This will indicate that a compressor contactor has failed closed. In this case, a special mode “Compressor Stuck on Control” will be enabled and all other compressors will be turned off and an alarm enabled to indicate that service is required. Indoor and outdoor fans will continue to operate. The first outdoor fan stage is turned on immediately. The second fan stage will turn on when outdoor-air

temperature (OAT) rises above 75 F or the highest active circuit saturated condensing temperature (SCT) rises above the HPSP and remains on until the condition is repaired regardless of the OAT and SCT values.

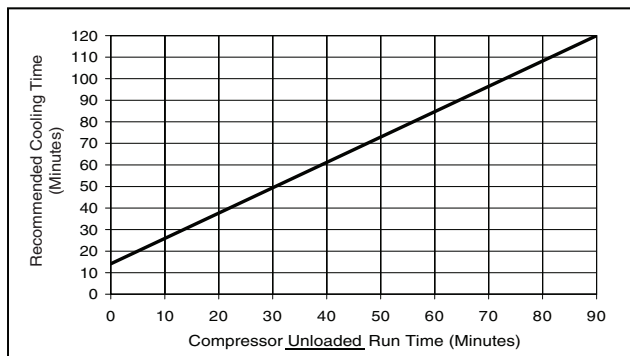
Any time the alert occurs, a strike is called out on the affected compressor. If three successive strikes occur the compressor will be locked out requiring a manual reset or power reset of the circuit board. The clearing of strikes during compressor operation is a combination of 3 complete cycles or 15 continuous minutes of run time operation. If there are one or two strikes on the compressor and three short cycles (ON-OFF, ON-OFF, ON-OFF) less than 15 minutes each occur, the strikes are reset to zero for the affected compressor. If the compressor turns on and runs for 15 minutes straight with no compressor failure, the compressor strikes are cleared.

Additionally, some units contain Copeland compressors equipped with advanced scroll temperature protection (ASTP). A label located above the terminal box identifies Copeland Scroll compressor models that contain this technology. See Fig. 5. Advanced scroll temperature protection is a form of internal discharge temperature protection that unloads the scroll compressor when the internal temperature reaches approximately 300 F. At this temperature, an internal bi-metal disk valve opens and causes the scroll elements to separate, which stops compression. Suction and discharge pressures balance while the motor continues to run. The longer the compressor runs unloaded, the longer it must cool before the bi-metal disk resets. See Fig. 6.

To manually reset ASTP, the compressor should be stopped and allowed to cool. If the compressor is not stopped, the motor



Fig. 5 — Advanced Scroll Temperature Protection Label



\*Times are approximate.

NOTE: Various factors, including high humidity, high ambient temperature, and the presence of a sound blanket will increase cool-down times.

Fig. 6 — Recommended Minimum Cool-Down Time After Compressor is Stopped\*

will run until the motor protector trips, which occurs up to 90 minutes later. Advanced scroll temperature protection will reset automatically before the motor protector resets, which may take up to 2 hours.

**COMPRESSOR TIME GUARDS** — The control will not allow any output relay to come on within 3 seconds of any other output relay. For outputs connected to the compressors, the control will use a Compressor Minimum OFF Time of 2 minutes, a Compressor Minimum ON Time of 3 minutes and a Minimum Delay before turning on another compressor of 10 seconds.

**COOL MODE SELECTION PROCESS** — The A Series ComfortLink controls offer three distinct methods by which it may select a cooling mode.

1. Thermostat (*C.TYP*=3 and 4): The thermostat does not depend upon the state of occupancy and the modes are called out directly by the discrete inputs from the thermostat (*Inputs* → *STAT* → *Y1* and *Y2*).
2. Occupied VAV cooling types (*C.TYP*=1 and 2) are called out in the occupied period (*Operating Modes* → *MODE* → *OCC=ON*).
3. Unoccupied VAV cooling types (*C.TYP*=1 and 2) are called out in the unoccupied period (*Operating Modes* → *MODE* → *OCC=OFF*). They are also used for space sensor control types (*C.TYP*=5 and 6) in both the occupied and unoccupied periods.

This section is devoted to the process of cooling mode determination for the three types outlined above.

**VAV Cool Mode Selection during the Occupied Period (*C.TYP* = 1,2 and *Operating Modes* → *MODE* → *OCC=ON*)**

— There is no difference in the selection of a cooling mode for either VAV-RAT or VAV-SPT in the occupied period. The actual selection of a cool mode, for both control types, is based upon the controlling return-air temperature (*Temperatures* → *AIR.T* → *CTRL* → *R.TMP*). Typically this is the same as the return air temperature thermistor (*Temperatures* → *AIR.T* → *RAT*) except when under CCN Linkage.

**VAV Occupied Cool Mode Evaluation Configuration** — There are VAV occupied cooling offsets under *Setpoints*.

ITEM	EXPANSION	RANGE	UNITS	CCN POINT	DEFAULT
<i>V.C.ON</i>	VAV Occ. Cool On Delta	0-25	°F	VAVOCON	3.5
<i>V.C.OF</i>	VAV Occ. Cool Off Delta	1-25	°F	VAVOCOFF	2

**Cool Mode Determination** — If the machine control type (*Configuration* → *UNIT* → *C.TYP*) = 1 (VAV-RAT) or 2 (VAV-SPT) and the control is occupied (*Operating Modes* → *MODE* → *OCC=ON*), then the unit will not follow the occupied cooling set point (*OCSP*). Instead, the control will follow two offsets in the determination of an occupied VAV cooling mode (*Setpoints* → *V.C.ON* and *Setpoints* → *V.C.OF*), applying them to the low-heat off trip point and comparing the resulting temperature to the return-air temperature.

The *Setpoints* → *V.C.ON* (VAV cool mode on offset) and *Setpoints* → *V.C.OF* (VAV cool mode off offset) offsets are used in conjunction with the low heat mode off trip point to determine when to bring cooling on and off and in enforcing a true “vent” mode between heating and cooling. See Fig. 7. The occupied cooling set point is not used in the determination of the cool mode. The occupied cooling set point is used for supply air reset only.

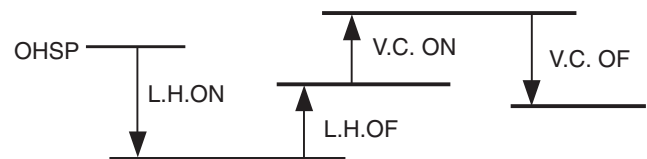


Fig. 7 — VAV Occupied Period Trip Logic

The advantage of this offset technique is that the control can safely enforce a vent mode without worrying about crossing set points. Even more importantly, under CCN linkage, the occupied heating set point may drift up and down and this method ensures a guaranteed separation in degrees Fahrenheit between the calling out of a heating or cooling mode at all times.

NOTE: There is a sub-menu at the local display (**Run Status** → **TRIP**) that allows the user to see the exact trip points for both the heating and cooling modes without having to calculate them. Refer to the Cooling Mode Diagnostic Help section on page 46 for more information.

To enter into a VAV Occupied Cool mode, the controlling temperature must rise above [OHSP minus L.H.ON plus L.H.OF plus V.C.ON].

To exit out of a VAV Occupied Cool mode, the controlling temperature must fall below [OHSP minus L.H.ON plus L.H.OF plus V.C.ON minus V.C.OF].

NOTE: With Vent mode, it is possible to exit out of a cooling mode during the occupied period if the return-air temperature drops low enough. When supply-air temperature reset is not configured, this capability will work to prevent over-cooling the space during the occupied period.

**Supply Air Set Point Control and the Staging of Compressors** — Once the control has determined that a cooling mode is in effect, the cooling control point (**Run Status** → **VIEW** → **CL.C.P**) is calculated and is based upon the supply air set point (**Setpoints** → **SASP**) plus any supply air reset being applied (**Inputs** → **RSET** → **SA.S.R**).

Refer to the SumZ Cooling Algorithm section on page 46 for a discussion of how the A Series ComfortLink controls manage the staging of compressors to maintain supply-air temperature.

**VAV Cool Mode Selection during the Unoccupied Period (C.TYP = 1,2; Operating Modes → MODE → OCC=OFF) and Space Sensor Cool Mode Selection (C.TYP=5 and 6)** —

The machine control types that use this type of mode selection are:

- **C.TYP** = 1 (VAV-RAT) in the unoccupied period
- **C.TYP** = 2 (VAV-SPT) in the unoccupied period
- **C.TYP** = 5 (SPT-MULTI) in both the occupied and unoccupied period
- **C.TYP** = 6 (SPT-2 STG) in both the occupied and unoccupied period

These particular control types operate differently than the VAV types in the occupied mode in that there is both a LOW COOL and a HIGH COOL mode. For both of these modes, the control offers two independent set points, **Setpoints** → **SA.LO** (for LOW COOL mode) and **Setpoints** → **SA.HI** (for HIGH COOL mode). The occupied and unoccupied cooling set points can be found under **Setpoints**.

ITEM	EXPANSION	RANGE	UNITS	CCN POINT	DEFAULT
<b>OCSP</b>	Occupied Cool Setpoint	55-80	dF	OCSP	75
<b>UCSP</b>	Unoccupied Cool Setpoint	75-95	dF	UCSP	90

The heat/cool set point offsets are found under **Configuration** → **D.LV.T**. See Table 48.

Operating modes are under **Operating Modes** → **MODE**.

ITEM	EXPANSION	RANGE	CCN POINT
<b>MODE</b>	MODES CONTROLLING UNIT		
<b>OCC</b>	Currently Occupied	ON/OFF	MODEOCCP
<b>T.C.ST</b>	Temp.Compensated Start	ON/OFF	MODETCST

**Cool Mode Evaluation Logic** — The first thing the control determines is whether the unit is in the occupied mode (**OCC**)

or is in the temperature compensated start mode (**T.C.ST**). If the unit is occupied or in temperature compensated start mode, the occupied cooling set point (**OCSP**) is used. For all other modes, the unoccupied cooling set point (**UCSP**) is used. For further discussion and simplification this will be referred to as the “cooling set point.” See Fig. 8.

**Demand Level Low Cool On Offset (L.C.ON)** — This is the cooling set point offset added to the cooling set point at which point a Low Cool mode starts.

**Demand Level High Cool On Offset (H.C.ON)** — This is the cooling set point offset added to the “cooling set point plus L.C.ON” at which point a High Cool mode begins.

**Demand Level Low Cool Off Offset (L.C.OF)** — This is the cooling set point offset subtracted from “cooling set point plus L.C.ON” at which point a Low Cool mode ends.

NOTE: The “high cool end” trip point uses the “low cool off” (**L.C.OF**) offset divided by 2.

To enter into a LOW COOL mode, the controlling temperature must rise above the cooling set point plus **L.C.ON**.

To enter into a HIGH COOL mode, the controlling temperature must rise above the cooling set point plus **L.C.ON** plus **H.C.ON**.

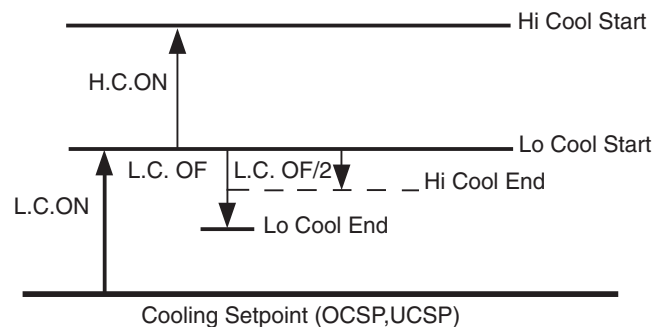
To exit out of a LOW COOL mode, the controlling temperature must fall below the cooling set point plus **L.C.ON** minus **L.C.OF**.

To exit out of a HIGH COOL mode, the controlling temperature must fall below the cooling set point plus **L.C.ON** minus **L.C.OF/2**.

**Comfort Trending** — In addition to the set points and offsets which determine the trip points for bringing on and bringing off cool modes, there are 2 configurations which work to hold off the transitioning from a low cool to a high cool mode if the space is cooling down quickly enough. This method is referred to as Comfort Trending. The comfort trending configurations are **C.TLV** and **C.TTM**.

**Cool Trend Demand Level (C.TLV)** — This is the change in demand that must occur within the time period specified by **C.TTM** in order to hold off a HIGH COOL mode regardless of demand. This is not applicable to VAV control types (**C.TYP**=1 and 2) in the occupied period. As long as a LOW COOL mode is making progress in cooling the space, the control will hold off on the HIGH COOL mode. This is especially true for the space sensor machine control types (**C.TYP** = 5 and 6), because they may transition into the occupied mode and see an immediate large cooling demand when the set points change.

**Cool Trend Time (C.TTM)** — This is the time period upon which the cool trend demand level (**C.TLV**) operates and may hold off staging or a HIGH COOL mode. This is not applicable to VAV control types (**C.TYP**=1 and 2) in the occupied period. See the Cool Trend Demand Level section for more details.



**Fig. 8 — Cool Mode Evaluation**



**Table 48 — Cool/Heat Set Point Offsets Configuration**

ITEM	EXPANSION	RANGE	UNITS	CCN POINT	DEFAULT
<i>D.LVT</i>	COOL/HEAT SETPT. OFFSETS				
<i>L.H.ON</i>	Dmd Level Lo Heat On	-1 - 2	^F	DMDLHON	1.5
<i>H.H.ON</i>	Dmd Level(+) Hi Heat On	0.5 - 20.0	^F	DMDHHON	0.5
<i>L.H.OF</i>	Dmd Level(-) Lo Heat Off	0.5 - 2	^F	DMDLHOFF	1
<i>L.C.ON</i>	Dmd Level Lo Cool On	-1 - 2	^F	DMDLCON	1.5
<i>H.C.ON</i>	Dmd Level(+) Hi Cool On	0.5 - 20.0	^F	DMDHCON	0.5
<i>L.C.OF</i>	Dmd Level(-) Lo Cool Off	0.5 - 2	^F	DMDLCOFF	1
<i>C.TLV</i>	Cool Trend Demand Level	0.1 - 5	^F	CTRENDLV	0.1
<i>H.TLV</i>	Heat Trend Demand Level	0.1 - 5	^F	HTRENDLV	0.1
<i>C.TTM</i>	Cool Trend Time	30 - 600	sec	CTRENDTM	120
<i>H.TTM</i>	Heat Trend Time	30 - 600	sec	HTRENDTM	120

*Timeguards* — In addition to the set points and offsets which determine the trip points for bringing on and bringing off cool modes there is a timeguard of 8 minutes which enforces a time delay between the transitioning from a low cool to a high cool mode. There is a timeguard of 5 minutes which enforces a time delay between the transitioning from a heat mode to a cool mode.

*Supply Air Set Point Control* — Once the control has determined that a cooling mode is in effect, the cooling control point (*Run Status*→*VIEW*→*CL.C.P*) is calculated and is based upon either *Setpoints*→*SA.HI* or *Setpoints*→*SA.LO*, depending on whether a high or a low cooling mode is in effect, respectively. In addition, if supply air reset is configured, it will also be added to the cooling control point.

Refer to the SumZ Cooling Algorithm section for a discussion of how the A Series *ComfortLink* controls manage supply-air temperature and the staging of compressors for these control types.

**Thermostat Cool Mode Selection (C.TYP = 3 and 4)** — When a thermostat type is selected, the decision making process involved in determining the mode is straightforward. Upon energizing the Y1 input only, the unit HVAC mode will be LOW COOL. Upon the energizing of both Y1 and Y2 inputs, the unit HVAC mode will be HIGH COOL. If just input G is energized the unit HVAC mode will be VENT and the supply fan will run.

Selecting the *C.TYP* = 3 (TSTAT – MULTI) control type will cause the control to do the following:

- The control will read the *Configuration*→*UNIT*→*SIZE* configuration parameter to determine the number of cooling stages and the pattern for each stage.
- An HVAC mode equal to LOW COOL will cause the unit to select the *Setpoints*→*SA.LO* set point to control to. An HVAC mode equal to HIGH COOL will cause the unit to select the *Setpoints*→*SA.HI* set point to control to. Supply air reset (if configured) will be added to either the low or high cool set point.
- The control will utilize the SumZ cooling algorithm and control cooling to a supply air set point. See the section for the SumZ Cooling Algorithm section for information on controlling to a supply air set point and compressor staging.

Selecting the *C.TYP* = 4 (TSTAT – 2 STG) control type means that only two stages of cooling will be used. On unit sizes 020, 025 and 027 (with three compressors), an HVAC Mode of LOW COOL will energize one compressor in Circuit A; an HVAC Mode of HIGH COOL will energize all three compressors. On unit sizes 030 and larger (with four compressors) an HVAC Mode of LOW COOL will energize both compressors in Circuit A; an HVAC Mode of HIGH COOL will energize all four compressors. Refer to the section on Economizer Integration with Mechanical Cooling for more information.

**2-Stage Cooling Control Logic (C.TYP = 4 and 6)** — The logic that stages mechanical cooling for the TSTAT and SPT 2-Stage cooling control types differs from that of the multi-stage control types. This section will explain how compressors

are staged and the timing involved for both the Low Cool and High Cool HVAC Modes.

There are either three or four compressors divided among two refrigeration circuits. Circuit A always contains two compressors (*Outputs*→*COOL*→*A1* and *A2*). Circuit B has either one compressor (*Outputs*→*COOL*→*B1*) on size 020-027 units or two compressors (*Outputs*→*COOL*→*B1* and *B2*) on size 030-060 units. For 2-stage cooling control, regardless of configuration, there is no minimum load valve (MLV) control. The decision as to which compressor should be turned on or off next is decided by the compressor’s availability and the preferred staging order.

Either A1 or A2 may start first as there is a built-in lead/lag logic on compressors A1 and A2 every time the unit stages to 0 compressors. Also, based on compressor availability, it should be noted that any compressor may come on. For example, on a 3 compressor unit, if no compressors are currently on, compressor A2 is currently under a minimum off compressor timeguard, and 2 compressors are to be turned on, then compressors A1 and B1 will be turned on immediately instead of A1 and A2.

*Low Cool Versus High Cool Mechanical Staging* — The number of compressors to be requested during a cooling mode are divided into 2 groups by the control, HVAC mode = Lo Cool and HVAC mode = Hi Cool.

If the economizer is not able to provide free cooling (*Run Status*→*ECON*→*ACTV* = NO) then the following staging occurs:

- Lo Cool Mode mechanical stages = 2
- Hi Cool Mode mechanical stages = 3 (for 020 through 027 size units)
- Hi Cool Mode mechanical stages = 4 (for 030 through 060 size units)

If the economizer is able to provide free cooling (*Run Status*→*ECON*→*ACTV* = YES) then the following staging occurs:

1. If the economizer’s current position is less than *Configuration*→*ECON*→*EC.MX* – 5 and mechanical cooling has not yet started for the current cool mode session then:  
Lo Cool Mode mechanical stages = 0  
Hi Cool Mode mechanical stages = 0
2. During the first 2.5 minutes of a low or high cool mode where the economizer position is greater than *Configuration*→*ECON*→*EC.MX* – 5% and mechanical cooling has not yet started:  
Lo Cool Mode mechanical stages = 0  
Hi Cool Mode mechanical stages = 0
3. If the economizer position is greater than *Configuration*→*ECON*→*EC.MX* – 5% for more than 2.5 minutes but less than 5.5 minutes and mechanical cooling has not yet started then:  
Lo Cool Mode mechanical stages = 1  
Hi Cool Mode mechanical stages = 1
4. If the economizer position is greater than *Configuration*→*ECON*→*EC.MX* – 5% for more than 5.5 minutes but less than 8 minutes and mechanical cooling has started

then Lo Cool Mode mechanical stages = 2 and Hi Cool Mode mechanical stages = 2.

- If the economizer position is greater than **Configuration** → **ECON** → **EC.MX** - 5% for more than 8 minutes but less than 11.5 minutes and mechanical cooling has started then:

Lo Cool Mode mechanical stages = 2

Hi Cool Mode mechanical stages = 3

- If the economizer position is greater than **Configuration** → **ECON** → **EC.MX** - 5% for more than 11.5 minutes and mechanical cooling has started then:

Lo Cool Mode mechanical stages = 2

Hi Cool Mode mechanical stages = 3 (for 020 to 027 units only)

Hi Cool Mode mechanical stages = 4 (for 030 to 060 units only)

NOTE: If some compressors are not available due to being faulted, the Hi Cool Mode number of compressors are affected before the Lo Cool Mode number of compressors. For example, if a 4 compressor unit has one compressor faulted, and the economizer is not active, then an HVAC mode Hi Cool requested number of compressors is changed from 4 to 3. If another compressor faults, then both Lo Cool and Hi Cool requested number of compressors are set to 2. In addition, compressors cannot be brought on faster than one every 30 seconds. If the control needs to bring on 2 compressors at once, the first compressor will come on followed by the second compressor 30 seconds later.

Staging of compressors is shown in Tables 49-60.

**EDT Low Override** — There is an override if EDT drops too low based on an alert limit that will lock out cooling. If the supply air/evaporator discharge temperature (EDT) falls below the alert limit (**Configuration** → **ALLM** → **S.A.L.O**) cooling will be inhibited. There is a 20-minute hold off on starting cooling again once the following statement is true: EDT minus (**Run Status** → **COOL** → **SUMZ** → **ADD.R**) has risen above **S.A.L.O**.

The variable **ADD.R** is one of the SumZ cooling algorithm control variables dedicated mainly for multi-stage control.

**2-Stage Control and the Economizer** — The 2-stage logic will first check for the availability of the economizer. If free cooling can be used, then the control will first attempt to use the free cooling.

If no mechanical cooling is active, and the economizer is active, the economizer will first attempt to control to a cooling control point of either the supply air set point high (**S.A.HI**) or supply air set point low (**S.A.LO**) plus any reset applied, depending on whether High Cool or Low Cool mode is in effect, respectively.

If one stage of mechanical cooling is on, and the economizer is active, then the economizer will attempt to control to 53 F. Also If HVAC mode = LOW COOL, the second stage of mechanical cooling will be locked out.

If the set point cannot be satisfied or the economizer is not active, then cooling will be brought on one stage at a time when the evaporator discharge temperature (EDT) is greater the 1.5° F above the current cooling control point. A start-up time delay of 10 minutes and steady state delay after a compressor is energized of 5 minutes is enforced.

If both circuits of mechanical cooling are running, then the economizer will attempt to control to 48 F. If the economizer is active and the outside-air temperature (OAT) is less than the cooling control point + 0.5 F, the compressors will be locked off. When mechanical cooling is on, the control may also use the economizer to trim the leaving-air temperature to prevent unnecessary cycles of the compressor stages.

See the Economizer Integration with Mechanical Cooling section on page 50 for more information on the holding off of mechanical cooling as well as the economizer control point.

**Table 49 — 2-Stage Sequence — 48/50AJ,AW020-027**

STAGE	SEQUENCE 1			SEQUENCE 2		
	0	1	2	0	1	2
	Thermostat Inputs			Thermostat Inputs		
Y1	OPEN	CLOSED	CLOSED	OPEN	CLOSED	CLOSED
Y2	OPEN	OPEN	CLOSED	OPEN	OPEN	CLOSED
COMP	Compressor Status			Compressor Status		
A1	OFF	ON	ON	OFF	OFF	ON
A2	OFF	OFF	ON	OFF	ON	ON
B1	OFF	OFF	ON	OFF	OFF	ON
UNIT	Unit Capacity			Unit Capacity		
020	0%	33%	100%	0%	33%	100%
025	0%	30%	100%	0%	30%	100%
027	0%	33%	100%	0%	33%	100%

**Table 50 — 2-Stage Sequence — 48/50AJ,AW030-060**

STAGE	SEQUENCE 1			SEQUENCE 2		
	0	1	2	0	1	2
	Thermostat Inputs			Thermostat Inputs		
Y1	OPEN	CLOSED	CLOSED	OPEN	CLOSED	CLOSED
Y2	OPEN	OPEN	CLOSED	OPEN	OPEN	CLOSED
COMP	Compressor Status			Compressor Status		
A1	OFF	ON	ON	OFF	ON	ON
A2	OFF	ON	ON	OFF	ON	ON
B1	OFF	OFF	ON	OFF	OFF	ON
B2	OFF	OFF	ON	OFF	OFF	ON
UNIT	Unit Capacity			Unit Capacity		
030	0%	45%	100%	0%	45%	100%
035,036	0%	48%	100%	0%	48%	100%
040,041	0%	43%	100%	0%	43%	100%
050	0%	45%	100%	0%	45%	100%
051,060	0%	50%	100%	0%	50%	100%

**Table 51 — Staging Sequence without Hot Gas Bypass — 48/50AK,AY020-027 and Multi-Stage 48/50AJ,AW020-027**

STAGE	SEQUENCE 1					SEQUENCE 2				
	0	1	2	3	4	0	1	2	3	4
COMP	Compressor Status					Compressor Status				
A1	OFF	ON	ON	OFF	ON	OFF	OFF	ON	ON	ON
A2	OFF	OFF	ON	ON	ON	OFF	ON	ON	OFF	ON
B1	OFF	OFF	OFF	ON	ON	OFF	OFF	OFF	ON	ON
UNIT	Unit Capacity 48/50A					Unit Capacity 48/50A				
020	0%	33%	67%	67%	100%	0%	33%	67%	67%	100%
025	0%	30%	65%	70%	100%	0%	35%	65%	65%	100%
027	0%	33%	67%	67%	100%	0%	33%	67%	67%	100%

**Table 52 — Staging Sequence with Hot Gas Bypass —  
48/50AK,AY020-027 and Multi-Stage 48/50AJ,AW020-027**

STAGE	SEQUENCE 1						SEQUENCE 2					
	0	1	2	3	4	5	0	1	2	3	4	5
COMP	Compressor Status						Compressor Status					
A1	OFF	ON*	ON	ON	OFF	ON	OFF	OFF	OFF	ON	ON	ON
A2	OFF	OFF	OFF	ON	ON	ON	OFF	ON*	ON	ON	OFF	ON
B1	OFF	OFF	OFF	OFF	ON	ON	OFF	OFF	OFF	OFF	ON	ON
UNIT	Unit Capacity 48/50A						Unit Capacity 48/50A					
020	0%	18%	33%	67%	67%	100%	0%	18%	33%	67%	67%	100%
025	0%	17%	30%	65%	70%	100%	0%	22%	35%	65%	65%	100%
027	0%	21%	33%	67%	67%	100%	0%	21%	33%	67%	67%	100%

\*With Minimum Load Valve ON.

**Table 53 — Staging Sequence without Hot Gas Bypass —  
48/50AK,AY030-060 and Multi-Stage 48/50AJ,AW030-060**

STAGE	SEQUENCE 1						SEQUENCE 2					
	0	1	2	3	4	5	0	1	2	3	4	5
COMP	Compressor Status						Compressor Status					
A1	OFF	ON	ON	OFF	ON	ON	OFF	OFF	ON	ON	ON	ON
A2	OFF	OFF	ON	ON	ON	ON	OFF	ON	ON	OFF	ON	ON
B1	OFF	OFF	OFF	ON	ON	ON	OFF	OFF	OFF	OFF	OFF	ON
B2	OFF	OFF	OFF	OFF	OFF	ON	OFF	OFF	OFF	ON	ON	ON
UNIT	Unit Capacity 48/50A						Unit Capacity 48/50A					
030	0%	23%	45%	50%	73%	100%	0%	23%	45%	50%	73%	100%
035,036	0%	22%	48%	52%	74%	100%	0%	26%	48%	48%	74%	100%
040,041	0%	21%	43%	50%	71%	100%	0%	21%	43%	50%	72%	100%
050	0%	23%	46%	46%	68%	100%	0%	23%	46%	54%	77%	100%
051	0%	25%	50%	50%	75%	100%	0%	25%	50%	50%	75%	100%
060	0%	24%	50%	50%	74%	100%	0%	26%	50%	50%	76%	100%

**Table 54 — Staging Sequence with Hot Gas Bypass — 48/50AK,AY030-060**

STAGE	SEQUENCE 1							SEQUENCE 2						
	0	1	2	3	4	5	6	0	1	2	3	4	5	6
COMP	Compressor Status							Compressor Status						
A1	OFF	ON*	ON	ON	OFF	ON	ON	OFF	OFF	OFF	ON	ON	ON	ON
A2	OFF	OFF	OFF	ON	ON	ON	ON	OFF	ON*	ON	ON	OFF	ON	ON
B1	OFF	OFF	OFF	OFF	ON	ON	ON	OFF	OFF	OFF	OFF	OFF	OFF	ON
B2	OFF	OFF	OFF	OFF	OFF	OFF	ON	OFF	OFF	ON	OFF	ON	ON	ON
UNIT	Unit Capacity 48/50A							Unit Capacity 48/50A						
030	0%	12%	23%	45%	50%	73%	100%	0%	12%	23%	45%	50%	73%	100%
035,036	0%	12%	22%	48%	52%	74%	100%	0%	16%	26%	48%	48%	74%	100%
040,041	0%	13%	21%	43%	50%	71%	100%	0%	13%	21%	43%	50%	72%	100%
050	0%	16%	23%	46%	46%	68%	100%	0%	16%	23%	46%	54%	77%	100%
051	0%	19%	25%	50%	50%	75%	100%	0%	19%	25%	50%	50%	75%	100%
060	0%	19%	24%	50%	50%	74%	100%	0%	21%	26%	50%	50%	76%	100%

\*With minimum load valve ON.

**Table 55 — 2-Stage Sequence —  
48/50A2,A4020-027**

STAGE	SEQUENCE 1			SEQUENCE 2		
	0	1	2	0	1	2
	Thermostat Inputs			Thermostat Inputs		
Y1	OPEN	CLOSED	CLOSED	OPEN	CLOSED	CLOSED
Y2	OPEN	OPEN	CLOSED	OPEN	OPEN	CLOSED
COMP	Compressor Status			Compressor Status		
A1	OFF	ON	ON	OFF	OFF	ON
A2	OFF	OFF	ON	OFF	ON	ON
B1	OFF	OFF	ON	OFF	OFF	ON
UNIT	Unit Capacity			Unit Capacity		
020	0%	30%	100%	0%	30%	100%
025	0%	33%	100%	0%	33%	100%
027	0%	33%	100%	0%	33%	100%

**Table 56 — 2-Stage Sequence —  
48/50A2,A4030-060**

STAGE	SEQUENCE 1			SEQUENCE 2		
	0	1	2	0	1	2
	Thermostat Inputs			Thermostat Inputs		
Y1	OPEN	CLOSED	CLOSED	OPEN	CLOSED	CLOSED
Y2	OPEN	OPEN	CLOSED	OPEN	OPEN	CLOSED
COMP	Compressor Status			Compressor Status		
A1	OFF	ON	ON	OFF	OFF	ON
A2	OFF	OFF	ON	OFF	ON	ON
B1	OFF	ON	ON	OFF	OFF	ON
B2	OFF	OFF	ON	OFF	ON	ON
UNIT	Unit Capacity			Unit Capacity		
030	0%	50%	100%	0%	50%	100%
035	0%	50%	100%	0%	50%	100%
040	0%	50%	100%	0%	50%	100%
050	0%	50%	100%	0%	50%	100%
060	0%	50%	100%	0%	50%	100%



**Table 57 — Staging Sequence without Hot Gas Bypass —  
48/50A3,A5020-027 and Multi-Stage 48/50A2,A4020-027**

STAGE	SEQUENCE 1				SEQUENCE 2			
	0	1	2	3	0	1	2	3
<b>COMP</b>	<b>Compressor Status</b>				<b>Compressor Status</b>			
<b>A1</b>	OFF	ON	ON	ON	OFF	OFF	OFF	ON
<b>A2</b>	OFF	OFF	OFF	ON	OFF	ON	ON	ON
<b>B1</b>	OFF	OFF	ON	ON	OFF	OFF	ON	ON
<b>UNIT</b>	<b>Unit Capacity 48/50A</b>				<b>Unit Capacity 48/50A</b>			
<b>020</b>	0%	30%	70%	100%	0%	30%	70%	100%
<b>025</b>	0%	33%	67%	100%	0%	33%	67%	100%
<b>027</b>	0%	33%	67%	100%	0%	33%	67%	100%

**Table 58 — Staging Sequence with Hot Gas Bypass —  
48/50A3,A5020-027 and Multi-Stage 48/50A2,A4020-027**

STAGE	SEQUENCE 1					SEQUENCE 2				
	0	1	2	3	4	0	1	2	3	4
<b>COMP</b>	<b>Compressor Status</b>					<b>Compressor Status</b>				
<b>A1</b>	OFF	ON*	ON	ON	ON	OFF	OFF	OFF	OFF	ON
<b>A2</b>	OFF	OFF	OFF	OFF	ON	OFF	ON*	ON	ON	ON
<b>B1</b>	OFF	OFF	OFF	ON	ON	OFF	OFF	OFF	ON	ON
<b>UNIT</b>	<b>Unit Capacity 48/50A</b>					<b>Unit Capacity 48/50A</b>				
<b>020</b>	0%	10%	30%	70%	100%	0%	10%	30%	70%	100%
<b>025</b>	0%	17%	33%	67%	100%	0%	17%	33%	67%	100%
<b>027</b>	0%	17%	33%	67%	100%	0%	17%	33%	67%	100%

\*With Minimum Load Valve ON.

**Table 59 — Staging Sequence without Hot Gas Bypass —  
48/50A3,A5030-060 and Multi-Stage 48/50A2,A4030-060**

STAGE	SEQUENCE 1					SEQUENCE 2				
	0	1	2	3	4	0	1	2	3	4
<b>COMP</b>	<b>Compressor Status</b>					<b>Compressor Status</b>				
<b>A1</b>	OFF	ON	ON	ON	ON	OFF	OFF	ON	OFF	ON
<b>A2</b>	OFF	OFF	OFF	ON	ON	OFF	ON	OFF	ON	ON
<b>B1</b>	OFF	OFF	ON	ON	ON	OFF	OFF	ON	ON	ON
<b>B2</b>	OFF	OFF	OFF	OFF	ON	OFF	OFF	OFF	ON	ON
<b>UNIT</b>	<b>Unit Capacity 48/50A</b>					<b>Unit Capacity 48/50A</b>				
<b>030</b>	0%	25%	50%	75%	100%	0%	25%	50%	75%	100%
<b>035</b>	0%	20%	50%	80%	100%	0%	20%	50%	70%	100%
<b>040</b>	0%	25%	50%	75%	100%	0%	25%	50%	75%	100%
<b>050</b>	0%	25%	50%	75%	100%	0%	25%	50%	75%	100%
<b>060</b>	0%	25%	50%	75%	100%	0%	25%	50%	75%	100%

**Table 60 — Staging Sequence with Hot Gas Bypass — 48/50A3,A5030-060**

STAGE	SEQUENCE 1						SEQUENCE 2					
	0	1	2	3	4	5	0	1	2	3	4	5
<b>COMP</b>	<b>Compressor Status</b>						<b>Compressor Status</b>					
<b>A1</b>	OFF	ON*	ON	ON	ON	ON	OFF	OFF	OFF	OFF	OFF	ON
<b>A2</b>	OFF	OFF	OFF	OFF	ON	ON	OFF	ON*	ON	ON	ON	ON
<b>B1</b>	OFF	OFF	OFF	ON	ON	ON	OFF	OFF	OFF	OFF	ON	ON
<b>B2</b>	OFF	OFF	OFF	OFF	OFF	ON	OFF	OFF	OFF	ON	ON	ON
<b>UNIT</b>	<b>Unit Capacity 48/50A</b>						<b>Unit Capacity 48/50A</b>					
<b>030</b>	0%	10%	25%	50%	75%	100%	0%	10%	25%	50%	75%	100%
<b>035</b>	0%	7%	20%	50%	80%	100%	0%	7%	20%	50%	70%	100%
<b>040</b>	0%	14%	25%	50%	75%	100%	0%	14%	25%	50%	75%	100%
<b>050</b>	0%	16%	25%	50%	75%	100%	0%	16%	25%	50%	75%	100%
<b>060</b>	0%	18%	25%	50%	75%	100%	0%	18%	25%	50%	75%	100%

\*With minimum load valve ON.

COOLING MODE DIAGNOSTIC HELP — To quickly determine the current trip points for the cooling modes, the Run Status sub-menu at the local display allows the user to view the calculated start and stop points for both the cooling and heating trip points. The following sub-menu can be found at the local display under *Run Status* → *TRIP*. See Table 61.

The controlling temperature is “TEMP” and is in the middle of the table for easy reference. The HVAC mode can also be viewed at the bottom of the table.

**Table 61 — Run Status Mode Trip Helper**

ITEM	EXPANSION	UNITS	CCN POINT
<i>TRIP</i>	MODE TRIP HELPER		
<i>UN.C.S</i>	Unoccup. Cool Mode Start	dF	UCCLSTRT
<i>UN.C.E</i>	Unoccup. Cool Mode End	dF	UCCL_END
<i>OC.C.S</i>	Occupied Cool Mode Start	dF	OCCLSTRT
<i>OC.C.E</i>	Occupied Cool Mode End	dF	OCCL_END
<i>TEMP</i>	Ctl.Temp RAT,SPT or Zone	dF	CTRLTEMP
<i>OC.H.E</i>	Occupied Heat Mode End	dF	OCHT_END
<i>OC.H.S</i>	Occupied Heat Mode Start	dF	OCHTSTRT
<i>UN.H.E</i>	Unoccup. Heat Mode End	dF	UCHT_END
<i>UN.H.S</i>	Unoccup. Heat Mode Start	dF	UCHTSTRT
<i>HVAC</i>	the current HVAC MODE		String

SUMZ COOLING ALGORITHM — The SumZ cooling algorithm is an adaptive PID which is used by the control whenever more than 2 stages of cooling are present (*C.TYP* = 1,2,3, and 5). This section will describe its operation and define its parameters. It is generally not necessary to modify parameters in this section. The information is presented primarily for reference and may be helpful for troubleshooting complex operational problems.

The only configuration parameter for the SumZ algorithm is located at the local display under *Configuration* → *COOL* → *Z.GN*. See Table 47.

Capacity Threshold Adjust (*Z.GN*) — This configuration is used on units using the “SumZ” algorithm for cooling capacity control (*Configuration* → *UNIT* → *C.TYP* = 1, 2, 3 and 5). It affects the cycling rate of the cooling stages by raising or lowering the threshold that capacity must overcome in order to add or subtract a stage of cooling.

The cooling algorithm’s run-time variables are located at the local display under *Run Status* → *COOL*. See Table 62.

Current Running Capacity (*C.CAP*) — This variable represents the amount of capacity in percent that is currently running.

Current Cool Stage (*CUR.S*) — This variable represents the cool stage currently running.

Requested Cool Stage (*REQ.S*) — This variable represents the cool stage currently requested by the control.

Maximum Cool Stages (*MAX.S*) — This variable is the maximum number of cooling stages the control is configured for and capable of controlling.

Active Demand Limit (*DEM.L*) — If demand limit is active, this variable will represent the amount of capacity that the control is currently limited to.

Capacity Load Factor (*SMZ*) — This factor builds up or down over time (–100 to +100) and is used as the means of adding or subtracting a cooling stage during run time. It is a normalized representation of the relationship between “Sum” and “Z.”

Next Stage EDT Decrease (*ADD.R*) — This variable represents (if adding a stage of cooling) how much the temperature

should drop in degrees depending on the *R.PCT* calculation and exactly how much additional capacity is to be added.

$ADD.R = R.PCT * (C.CAP$  — capacity after adding a cooling stage)

For example: If *R.PCT* = 0.2 and the control would be adding 20% cooling capacity by taking the next step up, 0.2 times 20 = 4 F (*ADD.R*).

Next Stage EDT Increase (*SUB.R*) — This variable represents (if subtracting a stage of cooling) how much the temperature should rise in degrees depending on the *R.PCT* calculation and exactly how much capacity is to be subtracted.

$SUB.R = R.PCT * (C.CAP$  — capacity after subtracting a cooling stage)

For Example: If *R.PCT* = 0.2 and the control would be subtracting 30% capacity by taking the next step down, 0.2 times –30 = –6 F (*SUB.R*)

Rise Per Percent Capacity (*R.PCT*) — This is a real time calculation that represents the amount of degrees of drop/rise across the evaporator coil versus percent of current running capacity.

$$R.PCT = (MAT - EDT) / C.CAP$$

Cap Deadband Subtracting (*Y.MIN*) — This is a control variable used for Low Temp Override (*L.TMP*) and Slow Change Override (*SLOW*).

$$Y.MIN = -SUB.R * 0.4375$$

Cap Deadband Adding (*Y.PLU*) — This is a control variable used for High Temp Override (*H.TMP*) and Slow Change Override (*SLOW*).

$$Y.PLU = -ADD.R * 0.4375$$

Cap Threshold Subtracting (*Z.MIN*) — This parameter is used in the calculation of SumZ and is calculated as follows:

$$Z.MIN = Configuration \rightarrow COOL \rightarrow Z.GN * (-10 + (4 * (-SUB.R))) * 0.6$$

Cap Threshold Adding (*Z.PLU*) — This parameter is used in the calculation of SumZ and is calculated as follows:

$$Z.PLU = Configuration \rightarrow COOL \rightarrow Z.GN * (10 + (4 * (-ADD.R))) * 0.6$$

High Temp Cap Override (*H.TMP*) — If stages of mechanical cooling are on and the error is greater than twice *Y.PLU*, and the rate of change of error is greater than 0.5° F per minute, then a stage of mechanical cooling will be added every 30 seconds. This override is intended to react to situations where the load rapidly increases.

Low Temp Cap Override (*L.TMP*) — If the error is less than twice *Y.MIN*, and the rate of change of error is less than –0.5° F per minute, then a mechanical stage will be removed every 30 seconds. This override is intended to quickly react to situations where the load is rapidly reduced.

Pull Down Cap Override (*PULL*) — If the error from set point is above 4° F, and the rate of change is less than –1° F per minute, then pulldown is in effect, and “SUM” is set to 0. This keeps mechanical cooling stages from being added when the error is very large, but there is no load in the space. Pulldown for units is expected to rarely occur, but is included for the rare situation when it is needed. Most likely pulldown will occur when mechanical cooling first becomes available shortly after the control goes into an occupied mode (after a warm unoccupied mode).

**Table 62 — Run Status Cool Display**

ITEM	EXPANSION	RANGE	UNITS	CCN POINT	WRITE STATUS
<b>COOL</b>	COOLING INFORMATION				
<b>C.CAP</b>	Current Running Capacity		%	CAPTOTAL	
<b>CUR.S</b>	Current Cool Stage			COOL_STG	
<b>REQ.S</b>	Requested Cool Stage			CL_STAGE	
<b>MAX.S</b>	Maximum Cool Stages			CLMAXSTG	
<b>DEM.L</b>	Active Demand Limit		%	DEM_LIM	forcible
<b>SUMZ</b>	COOL CAP. STAGE CONTROL				
<b>SMZ</b>	Capacity Load Factor	-100 – +100		SMZ	
<b>ADD.R</b>	Next Stage EDT Decrease		^F	ADDRISE	
<b>SUB.R</b>	Next Stage EDT Increase		^F	SUBRISE	
<b>R.PCT</b>	Rise Per Percent Capacity			RISE_PCT	
<b>Y.MIN</b>	Cap Deadband Subtracting			Y_MINUS	
<b>Y.PLU</b>	Cap Deadband Adding			Y_PLUS	
<b>Z.MIN</b>	Cap Threshold Subtracting			Z_MINUS	
<b>Z.PLU</b>	Cap Threshold Adding			Z_PLUS	
<b>H.TMP</b>	High Temp Cap Override			HI_TEMP	
<b>L.TMP</b>	Low Temp Cap Override			LOW_TEMP	
<b>PULL</b>	Pull Down Cap Override			PULLDOWN	
<b>SLOW</b>	Slow Change Cap Override			SLO_CHNG	

Slow Change Cap Override (**SLOW**) — With a rooftop unit, the design rise at 100% total unit capacity is generally around 30° F. For a unit with 4 stages, each stage represents about 7.5° F of change to EDT. If stages could reliably be cycled at very fast rates, the set point could be maintained very precisely. Since it is not desirable to cycle compressors more than 6 cycles per hour, slow change override takes care of keeping the PID under control when “relatively” close to set point.

**SumZ Operation** — The SumZ algorithm is an adaptive PID style of control. The PID is programmed within the control and the relative speed of staging can only be influenced by the user through the adjustment of the **Z.GN** configuration. The capacity control algorithm uses a modified PID algorithm, with a self adjusting gain which compensates for varying conditions, including changing flow rates across the evaporator coil.

Previous implementations of SumZ made static assumptions about the actual size of the next capacity jump up or down. This control uses a “rise per percent capacity” technique in the calculation of SumZ, instead of the previous “rise per stage” method. For each jump, up or down in capacity, the control will know beforehand the exact capacity change brought on. Better overall staging control can be realized with this technique.

**SUM Calculation** — The PID calculation of the “SUM” is evaluated once every 80 seconds.

$$\text{SUM} = \text{Error} + \text{“SUM last time through”} + (3 * \text{Error Rate})$$

Where:

SUM = the PID calculation, Error = EDT – Cooling Control Point, Error Rate = Error – “Error last time through”

NOTE: “Error” is limited to between -50 and +50 and “Error rate” is limited to between -20 and +20.

This “SUM” will be compared against the “Z” calculations in determining whether cooling stages should be added or subtracted.

**Z Calculation** — For the “Z” calculation, the control attempts to determine the entering and the leaving-air temperature of the evaporator coil and based upon the difference between the two during mechanical cooling, and then determines whether to add or subtract a stage of cooling. This is the adaptive element.

The entering-air temperature is referred to as **MAT** (mixed-air temperature) and the leaving-air temperature of the evaporator coil is referred to as **EDT** (evaporator discharge temperature). They are found at the local display under the **Temperatures** → **CTRL** sub-menu.

The main elements to be calculated and used in the calculation of SumZ are:

- 1) the rise per percent capacity (**R.PCT**)

- 2) the amount of expected rise for the next cooling stage addition

- 3) the amount of expected rise for the next cooling stage subtraction

The calculation of “Z” requires two variables, **Z.PLU** used when adding a stage and **Z.MIN** used when subtracting a stage. They are calculated with the following formulas:

$$\text{Z.PLU} = \text{Z.GN} * (10 + (4 * (-\text{ADD.R}))) * 0.6$$

$$\text{Z.MIN} = \text{Z.GN} * (-10 + (4 * (-\text{SUB.R}))) * 0.6$$

Where:

**Z.GN** = configuration used to modify the threshold levels used for staging (**Configuration** → **COOL** → **Z.GN**)

**ADD.R** = **R.PCT** \* (**C.CAP** – capacity after adding a cooling stage)

**SUB.R** = **R.PCT** \* (**C.CAP** – capacity after subtracting a cooling stage)

Both of these terms, **Z.PLU** and **Z.MIN**, represent a threshold both positive and negative upon which the “SUM” calculation must build up to in order to cause the compressor to stage up or down.

**Comparing SUM and Z** — The “SUM” calculation is compared against **Z.PLU** and **Z.MIN**.

- If “SUM” rises above **Z.PLU**, a cooling stage is added.
- If “SUM” falls below **Z.MIN**, a cooling stage is subtracted.

There is a variable called **SMZ** which is described in the reference section and which can simplify the task of watching the demand build up or down over time. It is calculated as follows:

$$\text{If SUM is positive: } \text{SMZ} = 100 * (\text{SUM} / \text{Z.PLU})$$

$$\text{If SUM is negative: } \text{SMZ} = -100 * (\text{SUM} / \text{Z.MIN})$$

**Mixed Air Temperature Calculation (MAT)** — The mixed-air temperature is calculated and is a function of the economizer position. Additionally there are some calculations in the control which can zero in over time on the relationship of return and outside air as a function of economizer position. There are two configurations which relate to the calculation of “MAT.” These configurations can be located at the local display under **Configuration** → **UNIT**.

ITEM	EXPANSION	RANGE	CCN POINT	DEFAULTS
<b>UNIT</b>	UNIT CONFIGURATION			
<b>MAT.S</b>	MAT Calc Config	0 - 2	MAT_SEL	1
<b>MAT.R</b>	Reset MAT Table Entries?	Yes/No	MATRESET	No

**MAT Calc Config (MATS)** — This configuration gives the user two options in the processing of the mixed-air temperature (MAT) calculation:

- **MATS = 0**  
There will be no MAT calculation.
- **MATS = 1**  
The control will attempt to learn MAT over time. Any time the system is in a vent mode and the economizer stays at a particular position for long enough, MAT = EDT. Using this method, the control has an internal table whereby it can more closely determine the true MAT value.
- **MATS = 2**  
The control will not attempt to learn MAT over time.  
To calculate MAT linearly, the user should reset the MAT table entries by setting **MATR** to YES. Then set **MATS = 2**. The control will calculate MAT based on the position of the economizer and outside air and return air temperature.  
To freeze the MAT table entries, let the unit run with **MATS = 1**. Once sufficient data has been collected, change **MATS = 2**. Do not reset the MAT table.

**Reset MAT Table Entries? (MATR)** — This configuration allows the user to reset the internally stored MAT learned configuration data back to the default values. The defaults are set to a linear relationship between the economizer damper position and OAT and RAT in the calculation of MAT.

**SumZ Overrides** — There are a number of overrides to the SumZ algorithm which may add or subtract stages of cooling.

- High Temp Cap Override (**H.TMP**)
- Low Temp Cap Override (**L.TMP**)
- Pull Down Cap Override (**PULL**)
- Slow Change Cap Override (**SLOW**)

**Economizer Trim Override** — The unit may drop stages of cooling when the economizer is performing free cooling and the configuration **Configuration → ECON → E.TRM** is set to Yes. The economizer controls to the same supply air set point as mechanical cooling does for SumZ when **E.TRM = Yes**. This allows for much tighter temperature control as well as cutting down on the cycling of compressors.

For a long cooling session where the outside-air temperature may drop over time, there may be a point at which the economizer has closed down far enough were the unit could remove a cooling stage and open up the economizer further to make up the difference.

**Mechanical Cooling Lockout (Configuration → COOL → MC.LO)** — This configuration allows a configurable outside-air temperature set point below which mechanical cooling will be completely locked out.

**DEMAND LIMIT CONTROL** — Demand Limit Control may override the cooling algorithm to limit or reduce cooling capacity during run time. The term Demand Limit Control refers to the restriction of machine capacity to control the amount of power that a machine will use. This can save the owner money by limiting peaks in the power supply. Demand limit control is intended to interface with an external Loadshed Device either through CCN communications, external switches, or 4 to 20 mA input.

The control has the capability of loadshedding and limiting in 3 ways:

- Two discrete inputs tied to configurable demand limit set point percentages.
- An external 4 to 20 mA input that can reset capacity back linearly to a set point percentage.
- CCN loadshed functionality.

NOTE: It is also possible to force the demand limit variable (**Run Status → COOL → DEM.L**).

To use Demand Limiting, select the type of demand limiting to use. This is done with the Demand Limit Select configuration (**Configuration → DMD.L → DM.L.S**).

To view the current demand limiting currently in effect, look at **Run Status → COOL → DEM.L**.

The configurations associated with demand limiting can be viewed at the local display at **Configuration → DMD.L**. See Table 63.

**Demand Limit Select (DM.L.S)** — This configuration determines the type of demand limiting.

- 0 = NONE — Demand Limiting not configured.
- 1 = 2 SWITCHES — This will enable switch input demand limiting using the switch inputs connected to the CEM board. Connections should be made to TB6-4,5,6.
- 2 = 4 to 20 mA — This will enable the use of a remote 4 to 20 mA demand limit signal. The CEM module must be used. The 4 to 20 mA signal must come from an externally sourced controller and should be connected to TB6-7,8.
- 3 = CCN LOADSHED — This will allow for loadshed and red lining through CCN communications.

**Two-Switch Demand Limiting (DM.L.S = 1)** — This type of demand limiting utilizes two discrete inputs:

**Demand Limit Switch 1 Setpoint (D.L.S1)** — Dmd Limit Switch Setpoint 1 (0-100% total capacity)

**Demand Limit 2 Setpoint (D.L.S2)** — Dmd Limit Switch Setpoint 2 (0-100% total capacity)

The state of the discrete switch inputs can be found at the local display:

**Inputs → GEN.I → DL.S1**

**Inputs → GEN.I → DL.S2**

The following table illustrates the demand limiting (**Run Status → COOL → DEM.L**) that will be in effect based on the logic of the applied switches:

Switch Status	Run Status → COOL → DEM.L = 1
<b>Inputs → GEN.I → DL.S1 = OFF</b> <b>Inputs → GEN.I → DL.S2 = OFF</b>	100%
<b>Inputs → GEN.I → DL.S1 = ON</b> <b>Inputs → GEN.I → DL.S2 = OFF</b>	<b>Configuration → DMD.L → D.L.S1</b>
<b>Inputs → GEN.I → DL.S1 = ON</b> <b>Inputs → GEN.I → DL.S2 = ON</b>	<b>Configuration → DMD.L → D.L.S2</b>
<b>Inputs → GEN.I → DL.S1 = OFF</b> <b>Inputs → GEN.I → DL.S2 = ON</b>	<b>Configuration → DMD.L → D.L.S2</b>

**4-20 mA Demand Limiting (DM.L.S = 2)** — If the unit has been configured for 4 to 20 mA demand limiting, then the **Inputs → 4-20 → DML.M** value is used to determine the amount of demand limiting in effect (**Run Status → COOL → DEM.L**). The Demand Limit at 20 mA (**D.L.20**) configuration must be set. This is the configured demand limit corresponding to a 20 mA input (0 to 100%).

The value of percentage reset is determined by a linear interpolation from 0% to "**D.L.20**"% based on the **Inputs → 4-20 → DML.M** input value.

The following examples illustrate the demand limiting (**Run Status → COOL → DEM.L**) that will be in effect based on amount of current seen at the 4 to 20 mA input, **DML.M**.

<b>D.L.20 = 80%</b> <b>DML.M = 4mA</b> <b>DEM.L = 100%</b>	<b>D.L.20 = 80%</b> <b>DML.M = 12 mA</b> <b>DEM.L = 90%</b>	<b>D.L.20 = 80%</b> <b>DML.M = 20mA</b> <b>DEM.L = 80%</b>
--	---	--

**CCN Loadshed Demand Limiting (DM.L.S = 3)** — If the unit has been configured for CCN Loadshed Demand Limiting, then the demand limiting variable (**Run Status → COOL → DEM.L**) is controlled via CCN commands.

**Table 63 — Demand Limit Configuration**

ITEM	EXPANSION	RANGE	UNITS	CCN POINT	DEFAULT
<b>DMD.L</b>	DEMAND LIMIT CONFIG.				
<b>DM.L.S</b>	Demand Limit Select	0 - 3		DMD_CTRL	0
<b>D.L.20</b>	Demand Limit at 20 ma	0 - 100	%	DMT20MA	100
<b>SH.NM</b>	Loadshed Group Number	0 - 99		SHED_NUM	0
<b>SH.DL</b>	Loadshed Demand Delta	0 - 60	%	SHED_DEL	0
<b>SH.TM</b>	Maximum Loadshed Time	0 - 120	min	SHED_TIM	60
<b>D.L.S1</b>	Demand Limit Sw.1 Setpt.	0 - 100	%	DLSWSP1	80
<b>D.L.S2</b>	Demand Limit Sw.2 Setpt.	0 - 100	%	DLSWSP2	50

The relevant configurations for this type of demand limiting are:

Loadshed Group Number (**SH.NM**) — CCN Loadshed Group number

Loadshed Demand Delta (**SH.DL**) — CCN Loadshed Demand Delta

Maximum Loadshed Time (**SH.TM**) — CCN Maximum Loadshed time

The Loadshed Group Number (**SH.NM**) corresponds to the loadshed supervisory device that resides elsewhere on the CCN network and broadcasts loadshed and redline commands to its associated equipment parts. The **SH.NM** variable will default to zero which is an invalid group number. This allows the loadshed function to be disabled until configured.

Upon reception of a redline command, the machine will be prevented from starting if it is not running. If it is running, then **DEM.L** is set equal to the current running cooling capacity (**Run Status** → **COOL** → **C.CAP**).

Upon reception of a loadshed command, the **DEM.L** variable is set to the current running cooling capacity (**Run Status** → **COOL** → **C.CAP**) minus the configured Loadshed Demand Delta (**SH.DL**).

A redline command or loadshed command will stay in effect until a Cancel redline or Cancel loadshed command is received, or until the configurable Maximum Loadshed time (**SH.TM**) has elapsed.

**HEAD PRESSURE CONTROL** — Condenser head pressure control for the 48/50A Series rooftops is controlled directly by the unit, except when the unit is equipped and configured for Motormaster® V control. The control is able to cycle up to three stages of outdoor fans (see Table 64) to maintain acceptable head pressure.

For 48/50AJ,AK,AW,AY units, fan stages will react to saturated condensing temperature (SCT) sensors (**Temperatures** → **REF.T** → **SCT.A** and **SCT.B**) which are connected to the condenser coils in circuit A and B. The control converts the temperatures to the corresponding refrigerant pressures (**Pressures** → **REF.P** → **DP.A** and **DP.B**).

For 48/50A2,A3,A4,A5 units, fan stages react to discharge pressure transducers (DPT) (**Pressures** → **REF.P** → **DP.A** and **DP.B**) which are connected to the compressor discharge piping in circuit A and B. The control converts the pressures to the corresponding saturated condensing temperatures (**Temperatures** → **REF.T** → **SCT.A** and **SCT.B**).

Unit size (**Configuration** → **UNIT** → **SIZE**), refrigerant type (**Configuration** → **UNIT** → **RFG.T**), and condenser heat exchanger type (**Configuration** → **UNIT** → **CND.T**) are used to determine if the second stage fans are configured to respond to a particular refrigerant circuit (independent control) or both refrigerant circuits (common control). The 48/50A2,A3,A4,A5060 units with microchannel (MCHX) condenser heat exchangers are the only units that utilize independent fan controls.

If the unit is equipped with the accessory Motormaster V control, the Motormaster installed configuration (**Configuration** → **COOL** → **M.M.**) must be set to YES if the

unit size (**Configuration** → **UNIT** → **SIZE**) is 60 tons and the condenser heat exchanger type (**Configuration** → **UNIT** → **CND.T**) is RTPF (round tube plate fin). This is because the condenser fan relay A (MBB Relay 6) output must be energized to enable the Motormaster V control and must not be turned off by the head pressure control algorithm. The size 60 ton unit with RTPF condenser heat exchangers offers 3 stages of head pressure control and is the one case where condenser fan relay A may be requested off during head pressure control operation. By configuring **M.M.** to YES, the control is instructed not to turn off the relay to attempt 3 stages of head pressure control.

There are two configurations provided for head pressure control that can be found at the local display:

- **Configuration** → **COOL** → **M.M.** – **Motor Master Control?**
- **Configuration** → **COOL** → **HPSP** – **Head Pressure Setpoint**

There are two outputs (MBB Relays) provided to control head pressure:

- **Outputs** → **FANS** → **CD.FA** – Condenser Fan Circuit A (MBB Relay 6 - OFC1,4). For size 60 ton units with MCHX condensers, MBB – Relay 6 drives OFC4 and compressor contactor B1 or B2 auxiliary contacts drive OFC1.
- **Outputs** → **FANS** → **CD.FB** – Condenser Fan Circuit B (MBB Relay 5 - OFC2)

**Head Pressure Control Operation** — The following logic describes the head pressure control routines for the unit sizes outlined in Table 64.

For 020 to 035 size units, there are two outdoor fans that are common to both refrigerant circuits. The control cycles two stages of outdoor fans, one fan per stage, to maintain acceptable head pressure.

For 036 to 050 size units, there are four outdoor fans that are common to both refrigerant circuits. The control cycles two stages of outdoor fans, two fans per stage, to maintain acceptable head pressure.

For 051 and 060 size units – There are six outdoor fans that are common to both refrigerant circuits (size 060 MCHX units have 4 fans). The control cycles three stages of outdoor fans, two fans for stage one, four fans for stage two, and six fans for stage three to maintain acceptable head pressure.

When a compressor has been commanded on, then condenser fan A (MBB Relay 6) will be energized (**CD.FA** = ON). Condenser fan A will remain on until all compressors have been commanded off. If the highest active circuit SCT is above the HPSP or if OAT is greater than 75 F then condenser fan B (MBB Relay 5) will be energized (**CD.FB** = ON). Condenser fan B will remain on until all compressors have been commanded off, or the highest active circuit SCT drops 40 F below the HPSP for greater than 2 minutes and OAT is less than 73 F.

NOTE: For size 60 units with RTPF condenser heat exchangers not configured for Motormaster control, the control stages down differently than the other units. For these units, the control will first turn off condenser fan relay A. After 2 minutes, the control will turn off relay B and turn back on relay A.

**Table 64 — Condenser Fan Staging**

FAN RELAY	48/50A UNIT SIZE			
	020-035	036-050	051,060	060 with MCHX
OFC1,4* (MBB - RELAY 6)	OFM1	OFM1, OFM2	OFM1, OFM2	OFM4
OFC2 (MBB - RELAY 5)	OFM2	OFM3, OFM4	OFM3, OFM4, OFM5, OFM6	OFM2
OFC3 C.A1-AUX or C.A2-AUX	NA	NA	NA	OFM3
OFC1* C.B1-AUX or C.B2-AUX	NA	NA	NA	OFM1

\* For size 60 ton units with MCHX condensers, MBB – Relay 6 drives OFC4 and compressor contactor B1 or B2 auxiliary contacts drive OFC1.

For 060 size units with MCHX condensers, there are four outdoor fans, two for each independent refrigerant circuit. The control cycles two stages of outdoor fans for each circuit, one fan per stage, to maintain acceptable head pressure.

When a circuit A compressor has been commanded on, then OFC3 is energized via the normally opened auxiliary contacts on the compressor contactors. The auxiliary contacts are wired such that turning on either circuit A compressor will energize OFC3. Contactor OFC3 will remain on until all circuit A compressors have been commanded off. If SCTA is above the HPSP or if OAT is greater than 75 F, then condenser fan A (MBB Relay 6) will be energized (**CD.FA** = ON) turning on OFC4. Condenser fan A will remain on until all compressors have been commanded off, or SCTA drops 40 F below the HPSP for greater than 2 minutes and OAT is less than 73 F.

When a circuit B compressor has been commanded on, then OFC1 is energized via the normally opened auxiliary contacts on the compressor contactors. The auxiliary contacts are wired such that turning on either circuit B compressor will energize OFC1. Contactor OFC1 will remain on until all circuit B compressors have been commanded off. If SCTB is above the HPSP or if OAT is greater than 75 F, then condenser fan B (MBB Relay 5) will be energized (**CD.FB** = ON) turning on OFC2. Condenser fan B will remain on until all compressors have been commanded off, or SCTB drops 40 F below the HPSP for greater than 2 minutes and OAT is less than 73 F.

**Failure Mode Operation** — If either of the SCT or DPT sensors fails, then the control defaults to head pressure control based on the OAT sensor. The control turns on the second fan stage when the OAT is above 65 F and stages down when OAT drops below 50 F.

If the OAT sensor fails, then the control defaults to head pressure control based on the SCT sensors. The control turns on the second fan stage when the highest active circuit SCT is above the HPSP and stages down when the highest active circuit SCT drops 40 F below the HPSP for longer than 2 minutes.

If the SCT, DPT, and OAT sensors have all failed, then the control turns on the first and second fan stages when any compressor is commanded on.

Compressor current sensor boards (CSB) are used on all units and are able to diagnose a compressor stuck on (welded contactor) condition. If the control commands a compressor off and the CSB detects current flowing to the compressor, then the first fan stage is turned on immediately. The second fan stage will turn on when OAT rises above 75 F or the highest active circuit SCT rises above the HPSP and remain on until the condition is repaired regardless of the OAT and SCT values.

**ECONOMIZER INTEGRATION WITH MECHANICAL COOLING** — When the economizer is able to provide free cooling (**Run Status** → **ECON** → **ACTV** = YES), mechanical cooling may be delayed or even held off indefinitely.

NOTE: Once mechanical cooling has started, this delay logic is no longer relevant.

**Economizer Mechanical Cooling Delay** — This type of mechanical cooling delay is relevant to the all machine control types.

If the economizer is able to provide free cooling at the start of a cooling session, the mechanical cooling algorithm checks the economizer's current position (**Run Status** → **ECON** → **ECN.P**) and compares it to the economizer's maximum position (**Configuration** → **ECON** → **EC.MX**) – 5%. Once the economizer has opened beyond this point a 2.5-minute timer starts. If the economizer stays beyond this point for 2.5 minutes continuously, the mechanical cooling algorithm is allowed to start computing demand and stage compressors.

**Economizer Control Point (Run Status → VIEW → EC.C.P)**

— There are 4 different ways to determine the economizer control point when the economizer is able to provide free cooling:

If no mechanical cooling is active and HVAC mode = LOW COOL

$$EC.C.P = \text{Setpoints} \rightarrow SA.LO + \text{Inputs} \rightarrow RSET \rightarrow SA.S.R$$

If no mechanical cooling is active and HVAC mode = HIGH COOL

$$EC.C.P = \text{Setpoints} \rightarrow SA.HI + \text{Inputs} \rightarrow RSET \rightarrow SA.S.R$$

When the first stage of mechanical cooling has started

**EC.C.P** = 53 F plus any economizer suction pressure reset applied

When the second stage of mechanical cooling has started

**EC.C.P** = 48 F plus any economizer suction pressure reset applied

**Heating Control** — The A Series *ComfortLink* control system offers control for 3 different types of heating systems to satisfy general space heating requirements: 2-stage gas heat, 2-stage electric heat and multiple-stage (staged) gas heat.

Variable air volume (VAV) type applications (**C.TYP** = 1, 2, 3, or 5) require that the space terminal positions be commanded to open to Minimum Heating positions when gas or electric heat systems are active, to provide for the unit heating system's Minimum Heating Airflow rate.

For VAV applications, the heat interlock relay (HIR) function provides the switching of a control signal intended for use by the VAV terminals. This signal must be used to command the terminals to open to their Heating Open positions. The HIR is energized whenever the Heating mode is active, an IAQ pre-occupied force is active, or if fire smoke modes, pressurization, or smoke purge modes are active.

**SETTING UP THE SYSTEM** — The heating configurations are located at the local display under **Configuration** → **HEAT**. See Table 65.

**Heating Control Type (HT.CF)** — The heating control types available are selected with this variable.

- 0 = No Heat
- 1 = Electric Heat
- 2 = 2 Stage Gas Heat
- 3 = Staged Gas Heat

**Heating Supply Air Set Point (HT.SP)** — In a low heat mode for staged gas heat, this is the supply air set point for heating.

**Table 65 — Heating Configuration**

ITEM	EXPANSION	RANGE	UNITS	CCN POINT	DEFAULT
<b>HEAT</b>	HEATING CONFIGURATION				
<b>HT.CF</b>	Heating Control Type	0 - 3		HEATTYPE	0*
<b>HT.SP</b>	Heating Supply Air Setpt	80 - 120	dF	SASPHEAT	85
<b>OC.EN</b>	Occupied Heating Enabled	Yes/No		HTOCCENA	No
<b>LAT.M</b>	MBB Sensor Heat Relocate	Yes/No		HTLATMON	No
<b>G.FOD</b>	Fan Off Delay, Gas Heat	45 - 600	sec	GAS_FOD	45
<b>E.FOD</b>	Fan Off Delay, Elec Heat	10 - 600	sec	ELEC_FOD	30
<b>SG.CF</b>	STAGED GAS CONFIGS				
<b>HT.ST</b>	Staged Gas Heat Type	0 - 4		HTSTGTYP	0*
<b>CAP.M</b>	Max Cap Change per Cycle	5 - 45		HTCAPMAX	45*
<b>M.R.DB</b>	S.Gas DB min.dF/PID Rate	0 - 5		HT_MR_DB	0.5
<b>S.G.DB</b>	St.Gas Temp. Dead Band	0 - 5	^F	HT_SG_DB	2
<b>RISE</b>	Heat Rise dF/sec Clamp	0.05 - 0.2		HTSGRISE	0.06
<b>LAT.L</b>	LAT Limit Config	0 - 20	^F	HTLATLIM	10
<b>LIM.M</b>	Limit Switch Monitoring?	Yes/No		HTLIMMON	Yes
<b>SW.H.T</b>	Limit Switch High Temp	110 - 180	dF	HT_LIMHI	170*
<b>SW.L.T</b>	Limit Switch Low Temp	100 - 170	dF	HT_LIMLO	160*
<b>HT.P</b>	Heat Control Prop. Gain	0 - 1.5		HT_PGAIN	1
<b>HT.D</b>	Heat Control Derv. Gain	0 - 1.5		HT_DGAIN	1
<b>HT.TM</b>	Heat PID Rate Config	60 - 300	sec	HTSGPIDR	90

\*Some defaults are model number dependent.

**Occupied Heating Enable (OC.EN)** — This configuration only applies when the unit’s control type (**Configuration** → **UNIT** → **C.TYP**) is configured for 1 (VAV-RAT) or 2 (VAV-SPT). If the user wants to have the capability of performing heating throughout the entire occupied period, then this configuration needs to be set to “YES.” Most installations do not require this capability, and if heating is installed, it is used to heat the building in the morning. In this case set **OC.EN** to “NO.”

NOTE: This unit does not support simultaneous heating and cooling. If significant simultaneous heating and cooling demand is expected, it may be necessary to provide additional heating or cooling equipment and a control system to provide occupants with proper comfort.

**MBB Sensor Heat Relocate (LAT.M)** — This option allows the user additional performance benefit when under CCN Linkage for the 2-stage electric and gas heating types. As two-stage heating types do not “modulate” to a supply air set point, no leaving air thermistor is required and none is provided. The evaporator discharge thermistor, which is initially installed upstream of the heater, can be repositioned downstream and the control can expect to sense this heat. While the control does not need this to energize stages of heat, the control can wait for a sufficient temperature rise before announcing a heating mode to a CCN linkage system (ComfortID™).

If the sensor is relocated, the user will now have the capability to view the leaving-air temperature at all times at **Temperatures** → **AIR.T** → **CTRL** → **LAT**.

NOTE: If the user does not relocate this sensor for the 2-stage electric or gas heating types and is under CCN Linkage, then the control will send a heating mode (if present) unconditionally to the linkage coordinator in the CCN zoning system regardless of the leaving-air temperature.

**Fan-Off Delay, Gas Heat (G.FOD)** — This configuration is the delay in seconds, after a gas heat mode has ended (**HT.CF=2,3**) that the control will continue to energize the supply fan.

**Fan-Off Delay, Elec Heat (E.FOD)** — This configuration is the delay in seconds, after an electric heat mode has ended (**HT.CF=1**) that the control will continue to energize the supply fan.

**HEAT MODE SELECTION PROCESS** — There are two possible heat modes that the control will call out for heating control: HVAC Mode = LOW HEAT and HVAC Mode = HIGH HEAT. These modes will be called out based on control type (**C.TYP**).

**VAV-RAT (C.TYP = 1) and VAV-SPT (C.TYP = 2)** — There is no difference in the selection of a heating mode for either

VAV-RAT or VAV-SPT, except that for VAV-SPT, space temperature is used in the unoccupied period to turn on the supply fan for 10 minutes before checking return-air temperature. The actual selection of a heat mode, LOW or HIGH for both control types, will be based upon the controlling return-air temperature.

With sufficient heating demand, there are still conditions that will prevent the unit from selecting a heat mode. First, the unit must be configured for a heat type (**Configuration** → **HEAT** → **HT.CF** not equal to “NONE”). Second, the unit has a configuration which can enable or disable heating in the occupied period except for a standard morning warmup cycle (**Configuration** → **HEAT** → **OC.EN**). See descriptions above in the Setting Up the System section for more information.

If the unit is allowed to select a heat mode, then the next step is an evaluation of demand versus set point. At this point, the logic is the same as for control types SPT Multi-Stage and SPT-2 Stage, (**C.TYP = 5,6**) except for the actual temperature compared against set point. See Temperature Driven Heat Mode Evaluation section.

**Tstat-Multi-Stage (C.TYP = 3) and Tstat-2 Stage (C.TYP = 4)** — There is no difference in the selection of a heat mode between the control types TSTAT 2-stage or TSTAT multi-stage. These selections only refer to how cooling will be handled. With thermostat control the W1 and W2 inputs determine whether the HVAC Mode is LOW or HIGH HEAT.

W1 = ON, W2 = OFF: HVAC MODE = LOW HEAT\*  
W2 = ON, W2 = ON: HVAC MODE = HIGH HEAT

\*If the heating type is either 2-stage electric or 2-stage gas, the unit may promote a low heat mode to a high heat mode.

NOTE: If W2 = ON and W1 is OFF, a “HIGH HEAT” HVAC Mode will be called out but an alert (T422) will be generated. See Alarms and Alerts section on page 94.

**SPT Multi-Stage (C.TYP = 5) and SPT 2 Stage (C.TYP = 6)** — There is no difference in the selection of a heat mode between the control types SPT 2-stage or SPT multi-stage. These selections only refer to how cooling will be handled. So, for a valid heating type selected (**HT.CF** not equal to zero) the unit is free to select a heating mode based on space temperature (SPT).

If the unit is allowed to select a heat mode, then the next step is an evaluation of demand versus set point. At this point, the logic is the same as for control types VAV-RAT and VAV-SPT (**C.TYP = 1,2**), except for the actual temperature compared against set point. See Temperature Driven Heat Mode Evaluation section on page 52.



**TEMPERATURE DRIVEN HEAT MODE EVALUATION** — This section discusses the control method for selecting a heating mode based on temperature. Regardless of whether the unit is configured for return air or space temperature, the logic is exactly the same. For the rest of this discussion, the temperature in question will be referred to as the “controlling temperature.”

First, the occupied and unoccupied heating set points under *Setpoints* must be configured.

ITEM	EXPANSION	RANGE	UNITS	CCN POINT	DEFAULT
OHSP	Occupied Heat Setpoint	55-80	dF	OHSP	68
UHSP	Unoccupied Heat Setpoint	40-80	dF	UHSP	55

Then, the heat/cool set point offsets under *Configuration* → *D.LVT* should be set. See Table 66.

Related operating modes are under *Operating Modes* → *MODE*.

ITEM	EXPANSION	RANGE	CCN POINT
MODE	MODES CONTROLLING UNIT	UNIT	
OCC	Currently Occupied	ON/OFF	MODEOCCP
T.C.ST	Temp. Compensated Start	ON/OFF	MODETCST

The first thing the control determines is whether the unit is in the occupied mode (*OCC*) or in the temperature compensated start mode (*T.C.ST*). If the unit is occupied or in temperature compensated start mode, the occupied heating set point (*OHSP*) is used. In all other cases, the unoccupied heating set point (*UHSP*) is used.

The control will call out a low or high heat mode by comparing the controlling temperature to the heating set point and the heating set point offset. The set point offsets are used as additional help in customizing and tweaking comfort into the building space.

**Demand Level Low Heat on Offset (*L.H.ON*)** — This is the heating set point offset below the heating set point at which point Low Heat starts.

**Demand Level High Heat on Offset (*H.H.ON*)** — This is the heating set point offset below the heating set point minus *L.H.ON* at which point high heat starts.

**Demand Level Low Heat Off Offset (*L.H.OF*)** — This is the heating set point offset above the heating set point minus *L.H.ON* at which point the Low Heat mode ends.

See Fig. 9 for an example of offsets.

To enter into a LOW HEAT mode, if the controlling temperature falls below the heating set point minus *L.H.ON*, then HVAC mode = LOW HEAT.

To enter into a HIGH HEAT mode, if the controlling temperature falls below the heating set point minus *L.H.ON* minus *H.H.ON*, then HVAC mode = HIGH HEAT.

To get out of a LOW HEAT mode, the controlling temperature must rise above the heating set point minus *L.H.ON* plus *L.H.OF*.

To get out of a HIGH HEAT mode, the controlling temperature must rise above the heating set point minus *L.H.ON* plus *L.H.OF/2*.

The Run Status table in the local display allows the user to see the exact trip points for both the heating and cooling modes without doing the calculations.

**Heat Trend Demand Level (*H.TLV*)** — This is the change in demand that must be seen within the time period specified by *H.TTM* in order to hold off a HIGH HEAT mode regardless of demand. This is not applicable to VAV control types (*C.TYP*=1 and 2) in the occupied period. This method of operation has been referred to as “Comfort Trending.” As long as a LOW HEAT mode is making progress in warming the space, the control will hold off on a HIGH HEAT mode. This is relevant for the space sensor machine control types (*C.TYP* = 5 and 6) because they may transition into the occupied mode and see an immediate and large heating demand when the set points change.

**Heat Trend Time (*H.TTM*)** — This is the time period upon which the heat trend demand level (*H.TLV*) operates and may work to hold off staging or a HIGH HEAT mode. This is not applicable to VAV control types (*C.TYP*=1 and 2) in the occupied period. See “Heat Trend Demand Level” section for more details.

**HEAT MODE DIAGNOSTIC HELP** — To quickly determine the current trip points for the low and high heat modes, there is a menu in the local display which lets the user quickly view the state of the system. This menu also contains the cool trip points as well. See Table 67 at the local display under *Run Status* → *TRIP*.

The controlling temperature is “TEMP” and is in the middle of the table for easy reference. Also, the “HVAC” mode can be viewed at the bottom of the table.

**HT.CF = 1,2 (Two-Stage Gas and Electric Heat Control)** — If the HVAC mode is LOW HEAT:

- If Electric Heat is configured, then the control will request the supply fan ON
- If Gas Heat is configured, then the IGC indoor fan input controls the supply fan request
- The control will turn on Heat Relay 1 (*HS1*)
- If Evaporator Discharge Temperature is less than 50 F, then the control will turn on Heat Relay 2 (*HS2*)\*

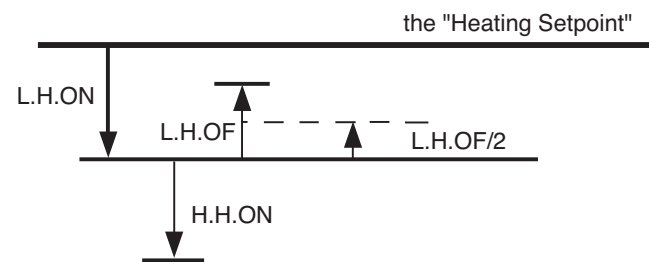


Fig. 9 — Heating Offsets

Table 66 — Heat/Cool Set Point Offsets

ITEM	EXPANSION	RANGE	UNITS	CCN POINT	DEFAULT
<i>D.LVT</i>	COOL/HEAT SETPT. OFFSETS				
<i>L.H.ON</i>	Dmd Level Lo Heat On	-1 - 2	^F	DMDLHON	1.5
<i>H.H.ON</i>	Dmd Level(+) Hi Heat On	0.5 - 20.0	^F	DMDHHON	0.5
<i>L.H.OF</i>	Dmd Level(-) Lo Heat Off	0.5 - 2	^F	DMDLHOFF	1
<i>L.C.ON</i>	Dmd Level Lo Cool On	-1 - 2	^F	DMDLCON	1.5
<i>H.C.ON</i>	Dmd Level(+) Hi Cool On	0.5 - 20.0	^F	DMDHCON	0.5
<i>L.C.OF</i>	Dmd Level(-) Lo Cool Off	0.5 - 2	^F	DMDLCOFF	1
<i>C.TLV</i>	Cool Trend Demand Level	0.1 - 5	^F	CTRENDLV	0.1
<i>H.TLV</i>	Heat Trend Demand Level	0.1 - 5	^F	HTRENDLV	0.1
<i>C.T.TM</i>	Cool Trend Time	30 - 600	sec	CTRENDTM	120
<i>H.T.TM</i>	Heat Trend Time	30 - 600	sec	HTRENDTM	120



**Table 67 — Mode Trip Helper Table**

ITEM	EXPANSION	UNITS	CCN POINT
<b>TRIP</b>	MODE TRIP HELPER		
<b>UN.C.S</b>	Unoccup. Cool Mode Start	dF	UCCLSTRT
<b>UN.C.E</b>	Unoccup. Cool Mode End	dF	UCCL_END
<b>OC.C.S</b>	Occupied Cool Mode Start	dF	OCCLSTRT
<b>OC.C.E</b>	Occupied Cool Mode End	dF	OCCL_END
<b>TEMP</b>	Ctl.Temp RAT,SPT or Zone	dF	CTRLTEMP
<b>OC.H.E</b>	Occupied Heat Mode End	dF	OCHT_END
<b>OC.H.S</b>	Occupied Heat Mode Start	dF	OCHTSTRT
<b>UN.H.E</b>	Unoccup. Heat Mode End	dF	UCHT_END
<b>UN.H.S</b>	Unoccup. Heat Mode Start	dF	UCHTSTRT
<b>HVAC</b>	the current HVAC MODE		String

If the HVAC mode is HIGH HEAT:

- If Electric Heat is configured, then the control will request the supply fan ON
- If Gas Heat is configured, then the IGC indoor fan input controls the supply fan request
- The control will turn on Heat Relay 1 (**HS1**)
- The control will turn on Heat Relay 2 (**HS2**)

\*The logic for this “low heat” override is that one stage of heating will not be able to raise the temperature of the supply airstream sufficient to heat the space.

**HT.CF = 3 (Staged Gas Heating Control)** — As an option, the units with gas heat can be equipped with staged gas heat controls that will provide from 5 to 11 stages of heat capacity. This is intended for tempering mode and tempering economizer air when in a cooling mode and the dampers are fully closed. Tempering can also be used during a pre-occupancy purge to prevent low temperature air from being delivered to the space. Tempering for staged gas will be discussed in its own section. This section will focus on heat mode control, which ultimately is relevant to tempering, minus the consideration of the supply air heating control point.

The staged gas configurations are located at the local display under **Configuration** → **HEAT** → **SGCF**. See Table 68.

**Staged Gas Heat Type (HT.ST)** — This configuration sets the number of stages and the order that are they staged.

**Max Cap Change per Cycle (CAP.M)** — This configuration limits the maximum change in capacity per PID run time cycle.

**S.Gas DB Min.dF/PID Rate (M.R.DB)** — This configuration is a deadband minimum temperature per second rate. See Staged Gas Heating logic below for more details.

**St.Gas Temp.Dead Band (S.GDB)** — This configuration is a deadband delta temperature. See Staged Gas Heating Logic below for more details.

**Heat Rise in dF/Sec Clamp (RISE)** — This configuration prevents the heat from staging up when the leaving-air temperature is rising too fast.

**LAT Limit Config (LAT.L)** — This configuration senses when leaving-air temperature is outside a delta temperature band around set point and allows staging to react quicker.

**Limit Switch Monitoring? (LIM.M)** — This configuration allows the operation of the limit switch monitoring routine. This should be set to NO as a limit switch temperature sensor is not used with A Series units.

**Limit Switch High Temp (SW.H.T)** — This configuration is the temperature limit above which stages of heat will be removed.

**Limit Switch Low Temp (SW.L.T)** — This configuration is the temperature limit above which no additional stages of heat will be allowed.

**Heat Control Prop. Gain (HT.P)** — This configuration is the proportional term for the PID which runs in the HVAC mode LOW HEAT.

**Heat Control Derv. Gain (HT.D)** — This configuration is the derivative term for the PID which runs in the HVAC mode LOW HEAT.

**Heat PID Rate Config (HT.TM)** — This configuration is the PID run time rate.

**Staged Gas Heating Logic**

If the HVAC mode is HIGH HEAT:

- The supply fan for staged gas heating is controlled by the integrated gas control (IGC) boards and, unless the supply fan is on for a different reason, it will be controlled by the IGC indoor fan input.
- Command all stages of heat ON

If the HVAC mode is LOW HEAT:

- The supply fan for staged gas heating is controlled by the integrated gas control (IGC) boards and, unless the supply fan is on for a different reason, it will be controlled by the IGC indoor fan input.
- The unit will control stages of heat to the heating control point (**Run Status** → **VIEW** → **HT.C.P**). The heating control point in a LOW HEAT HVAC mode for staged gas is the heating supply air set point (**Setpoints** → **SA.HT**).

**Staged Gas Heating PID Logic** — The heat control loop is a PID (proportional/integral/derivative) design with exceptions, overrides, and clamps. Capacity rises and falls based on set point and supply-air temperature. When the staged gas control is in Low Heat or Tempering Mode (HVAC mode), the algorithm calculates the desired heat capacity. The basic factors that govern the controlling method are:

- how fast the algorithm is run.
- the amount of proportional and derivative gain applied.
- the maximum allowed capacity change each time this algorithm is run.
- deadband hold-off range when rate is low.

**Table 68 — Staged Gas Configuration**

ITEM	EXPANSION	RANGE	UNITS	CCN POINT	DEFAULTS
<b>SG.CF</b>	STAGED GAS CONFIGS				
<b>HT.ST</b>	Staged Gas Heat Type	0 - 4		HTSTGTYP	0*
<b>CAP.M</b>	Max Cap Change per Cycle	5 - 45		HTCAPMAX	45*
<b>M.R.DB</b>	S.Gas DB min.dF/PID Rate	0 - 5		HT_MR_DB	0.5
<b>S.G.DB</b>	St.Gas Temp. Dead Band	0 - 5	^F	HT_SG_DB	2
<b>RISE</b>	Heat Rise dF/sec Clamp	0.05 - 0.2		HTSGRISE	0.06
<b>LAT.L</b>	LAT Limit Config	0 - 20	^F	HTLATLIM	10
<b>LIM.M</b>	Limit Switch Monitoring?	Yes/No		HTLIMMON	Yes
<b>SW.H.T</b>	Limit Switch High Temp	110 - 180	dF	HT_LIMHI	170*
<b>SW.L.T</b>	Limit Switch Low Temp	100 - 170	dF	HT_LIMLO	160*
<b>HT.P</b>	Heat Control Prop. Gain	0 - 1.5		HT_PGAIN	1
<b>HT.D</b>	Heat Control Derv. Gain	0 - 1.5		HT_DGAIN	1
<b>HT.TM</b>	Heat PID Rate Config	60 - 300	sec	HTSGPIDR	90

\*Some configurations are model number dependent.

This routine is run once every *HTTM* seconds. Every time the routine is run, the calculated sum is added to the control output value. In this manner, integral effect is achieved. Every time this algorithm is run, the following calculation is performed:

$$\text{Error} = \text{HT.C.P} - \text{LAT}$$

Error\_last = error calculated previous time

$$P = \text{HT.P} * (\text{Error})$$

$$D = \text{HT.D} * (\text{Error} - \text{Error\_last})$$

The P and D terms are overridden to zero if:

Error < *S.GDB* AND Error > - *S.GDB* AND D < *M.R.DB* AND D > - *M.R.DB*. “P + D” are then clamped based on *CAPM*. This sum can be no larger or no smaller than +*CAPM* or -*CAPM*.

Finally, the desired capacity is calculated:

Staged Gas Capacity Calculation = “P + D” + old Staged Gas Capacity Calculation

NOTE: The PID values should not be modified without approval from Carrier.

**IMPORTANT:** When gas or electric heat is used in a VAV application with third party terminals, the HIR relay output must be connected to the VAV terminals in the system in order to enforce a minimum heating airflow rate. The installer is responsible to ensure the total minimum heating cfm is not below limits set for the equipment. Failure to do so will result in limit switch tripping and may void warranty.

**Staged Gas Heat Staging** — Different unit sizes will control heat stages differently based on the amount of heating capacity included. These staging patterns are selected based on the model number. The selection of a set of staging patterns is controlled via the heat stage type configuration parameter (*HT.ST*). As the heating capacity rises and falls based on demand, the staged gas control logic will stage the heat relay patterns up and down, respectively. The Heat Stage Type configuration selects one of 4 staging patterns that the stage gas control will use. In addition to the staging patterns, the capacity for each stage is also determined by the staged gas heating PID control. Therefore, choosing the heat relay outputs is a function of the capacity desired, the heat staging patterns based on the heat stage type (*HT.ST*) and the capacity presented by each staging pattern. As the staged gas control desired capacity rises, it is continually checked against the capacity of the next staging pattern.

When the desired capacity is greater than or equal to the capacity of the next staging pattern, the next heat stage is selected (*Run Status* → *VIEW* → *HT.ST* = *Run Status* → *VIEW* → *HT.ST* + 1). Similarly, as the capacity of the control drops, the desired capacity is continually checked against the next lower stage. When the desired capacity is less than or equal to the next

lower staging pattern, the next lower heat stage pattern is selected (*Run Status* → *VIEW* → *HT.ST* = *Run Status* → *VIEW* → *HT.ST* - 1). The first two staged gas heat outputs are located on the MBB board and outputs 3, 4, 5, and 6 are located on the SCB board. These outputs are used to produce 5 to 11 stages as shown in Tables 69A and 69B. The heat stage selected (*Run Status* → *VIEW* → *HT.ST*) is clamped between 0 and the maximum number of stages possible (*Run Status* → *VIEW* → *H.MAX*) for the chosen set of staging patterns. See Tables 70-73.

**INTEGRATED GAS CONTROL BOARD LOGIC** — All gas heat units are equipped with one or more integrated gas control (IGC) boards. This board provides control for the ignition system for the gas heat sections. On size 020-050 low heat units there will be one IGC board. On size 020-050 high heat units and 051 and 060 low heat units there are two IGC boards. On size 051 and 060 high heat units there are three IGC boards. When a call for gas heat is initiated, power is sent to W on the IGC boards. For standard 2-stage heat, all boards are wired in parallel. For staged gas heat, each board is controlled separately. When energized, an LED on the IGC board will be turned on. See Table 74 for LED explanations. Each board will ensure that the rollout switch and limit switch are closed. The induced-draft motor is then energized. When the speed of the motor is proven with the Hall Effect sensor on the motor, the ignition activation period begins. The burners ignite within 5 seconds. If the burners do not light, there is a 22-second delay before another 5-second attempt is made. If the burners still do not light, this sequence is repeated for 15 minutes. After 15 minutes have elapsed and the burners have not ignited then heating is locked out. The control will reset when the request for W (heat) is temporarily removed. When ignition occurs, the IGC board will continue to monitor the condition of the rollout switch, limit switches, Hall Effect sensor, and the flame sensor. Forty-five seconds after ignition has occurred, the IGC will request that the indoor fan be turned on. The IGC fan output (IFO) is connected to the indoor fan input on the MBB which will indicate to the controls that the indoor fan should be turned on (if not already on). If for some reason the overtemperature limit switch trips prior to the start of the indoor fan blower, on the next attempt the 45-second delay will be shortened by 5 seconds. Gas will not be interrupted to the burners and heating will continue. Once modified, the fan delay will not change back to 45 seconds unless power is reset to the control. The IGC boards only control the first stage of gas heat on each gas valve. The second stages are controlled directly from the MBB board. The IGC board has a minimum on-time of 1 minute. In modes such as Service Test where long minimum on times are not enforced, the 1-minute timer on the IGC will still be followed and the gas will remain on for a minimum of 1 minute.

**Table 69A — Staged Gas Heat — 48AJ,AK,AW,AY Units**

UNIT SIZE	HEAT CAPACITY	UNIT MODEL NO. POSITION NO. 5	<i>Configuration</i> → <i>HEAT</i> → <i>SG.CF</i> → <i>HT.ST</i> ENTRY VALUE
020-035	Low	S	1 = 5 STAGE
	High	T	2 = 7 STAGE
036-050	Low	S	1 = 5 STAGE
	High	T	1 = 5 STAGE
051,060	Low	S	4 = 11 STAGE
	High	T	3 = 9 STAGE

**Table 69B — Staged Gas Heat — 48A2,A3,A4,A5 Units**

UNIT SIZE	HEAT CAPACITY	UNIT MODEL NO. POSITION NO. 5	Configuration → HEAT → SG.CF → HT.ST ENTRY VALUE
020-030	Low	S	1 = 5 STAGE
	High	T	2 = 7 STAGE
035-050	Low	S	1 = 5 STAGE
	High	T	1 = 5 STAGE
060	Low	S	4 = 11 STAGE
	High	T	3 = 9 STAGE

**Table 70 — Staged Gas Heat Control Steps (Configuration → HEAT → SG.CF → HT.ST = 1)**

STAGE	RELAY OUTPUT						CAPACITY %
	Heat 1	Heat 2	Heat 3	Heat 4	Heat 5	Heat 6	
	MBB-RLY8	MBB-RLY7	SCB-RLY1	SCB-RLY2	SCB-RLY3	SCB-RLY4	
	IGC1	MGV1	IGC2	MGV2	IGC3	MGV3	
0	OFF	OFF	OFF	OFF	OFF	OFF	0
1	ON	OFF	OFF	OFF	OFF	OFF	37
2	ON	ON	OFF	OFF	OFF	OFF	50
3	ON	OFF	ON	OFF	OFF	OFF	75
4	ON	ON	ON	OFF	OFF	OFF	87
5	ON	ON	ON	ON	OFF	OFF	100

**Table 71 — Staged Gas Heat Control Steps (Configuration → HEAT → SG.CT → HT.ST = 2)**

STAGE	RELAY OUTPUT						CAPACITY %
	Heat 1	Heat 2	Heat 3	Heat 4	Heat 5	Heat 6	
	MBB-RLY8	MBB-RLY7	SCB-RLY1	SCB-RLY2	SCB-RLY3	SCB-RLY4	
	IGC1	MGV1	IGC2	MGV2	IGC3	MGV3	
0	OFF	OFF	OFF	OFF	OFF	OFF	0
1	ON	OFF	OFF	OFF	OFF	OFF	25
2	ON	ON	OFF	OFF	OFF	OFF	33
3	OFF	OFF	ON	OFF	OFF	OFF	50
4	OFF	OFF	ON	ON	OFF	OFF	67
5	ON	OFF	ON	OFF	OFF	OFF	75
6	ON	ON	ON	OFF	OFF	OFF	83
7	ON	ON	ON	ON	OFF	OFF	100

**Table 72 — Staged Gas Heat Control Steps (Configuration → HEAT → SG.CT → HT.ST = 3)**

STAGE	RELAY OUTPUT						CAPACITY %
	Heat 1	Heat 2	Heat 3	Heat 4	Heat 5	Heat 6	
	MBB-RLY8	MBB-RLY7	SCB-RLY1	SCB-RLY2	SCB-RLY3	SCB-RLY4	
	IGC1	MGV1	IGC2	MGV2	IGC3	MGV3	
0	OFF	OFF	OFF	OFF	OFF	OFF	0
1	ON	OFF	OFF	OFF	OFF	OFF	25
2	ON	ON	OFF	OFF	OFF	OFF	33
3	ON	OFF	ON	OFF	OFF	OFF	50
4	ON	ON	ON	OFF	OFF	OFF	58
5	ON	ON	ON	ON	OFF	OFF	67
6	ON	OFF	ON	OFF	ON	OFF	75
7	ON	OFF	ON	ON	ON	OFF	83
8	ON	ON	ON	ON	ON	OFF	92
9	ON	ON	ON	ON	ON	ON	100

**Table 73 — Staged Gas Heat Control Steps (Configuration→HEAT→SG.CT→HT.ST = 4)**

STAGE	RELAY OUTPUT						CAPACITY %
	Heat 1	Heat 2	Heat 3	Heat 4	Heat 5	Heat 6	
	MBB-RLY8	MBB-RLY7	SCB-RLY1	SCB-RLY2	SCB-RLY3	SCB-RLY4	
	IGC1	MGV1	IGC2	MGV2	IGC3	MGV3	
0	OFF	OFF	OFF	OFF	OFF	OFF	0
1	ON	OFF	OFF	OFF	OFF	OFF	19
2	ON	ON	OFF	OFF	OFF	OFF	25
3	ON	OFF	OFF	OFF	ON	OFF	38
4	ON	ON	OFF	OFF	ON	OFF	44
5	ON	ON	OFF	OFF	ON	ON	50
6	ON	OFF	ON	OFF	OFF	OFF	57
7	ON	ON	ON	OFF	OFF	OFF	63
8	ON	OFF	ON	OFF	ON	OFF	76
9	ON	OFF	ON	ON	ON	OFF	88
10	ON	ON	ON	ON	ON	OFF	94
11	ON	ON	ON	ON	ON	ON	100

**Table 74 — IGC LED Indicators**

LED INDICATION	ERROR CODE
On	Normal Operation
Off	Hardware Failure
1 Flash	Fan On/Off Delay Modified
2 Flashes	Limit Switch Fault
3 Flashes	Fame Sense Fault
4 Flashes	Five Consecutive Limit Switch Faults
5 Flashes	Ignition Lockout Fault
6 Flashes	Ignition Switch Fault
7 Flashes	Rollout Switch Fault
8 Flashes	Internal Control Fault
9 Flashes	Software Lockout

**NOTES:**

1. There is a 3-second pause between error code displays.
2. If more than one error code exists, all applicable error codes will be displayed in numerical sequence.
3. Error codes on the IGC will be lost if power to the unit is interrupted.

**RELOCATE SAT (Supply Air Temperature) SENSOR FOR HEATING IN LINKAGE APPLICATIONS** — On CCN installations employing ComfortID™ terminals, the factory SAT location must be changed to a new location downstream of the unit’s heating system. The ComfortID terminal controls read the SAT value for their “proof-of-heat” sequence before terminals open to Minimum Heating positions during unit heating sequence.

Determine a location in the supply duct that will provide a fairly uniform airflow. Typically this would be a minimum of 5 equivalent duct diameters downstream of the unit. Also, care should be taken to avoid placing the thermistor within a direct line-of-sight of the heating element to avoid radiant effects.

Run a new two-wire conductor cable from the control box through the low voltage conduit into the space inside the building and route the cable to the new sensor location.

**Installing a New Sensor** — A field-provided duct-mount temperature sensor (Carrier P/N 33ZCSENPAT or equivalent 10 kilo-ohm at 25 C NTC [negative temperature coefficient] sensor) is required. Install the sensor through the side wall of the duct and secure.

**Re-Using the Factory SAT Sensor** — The factory sensor is attached to one of the supply fan housings. Disconnect the sensor from the factory harness. Drill a hole insert the sensor through the duct wall and secure in place.

Attach the new conductor cable to the sensor leads and terminate in an appropriate junction box. Connect the opposite end inside the unit control box at the factory leads from MBB

J8 terminals 11 and 12 (PNK) leads. Secure the unattached PNK leads from the factory harness to ensure no accidental contact with other terminals inside the control box.

**MORNING WARM UP** — Morning Warm Up is a period of time that assists CCN linkage in opening up downstream zone dampers for the first heating cycle of a day.

The Morning Warm Up Period is CCN linkage mode “2” and is relayed in the following conditions:

- Temperature Compensated Start Mode is active AND Heat Mode in effect AND LAT is warm enough or is to be ignored due to placement.
- The unit just went into occupied mode and there has been no cooling mode yet and a heat cycle occurs or was in progress when the unit went occupied.

In both cases, if and when the heat mode terminates, a heat cycle has occurred and any subsequent heat cycles will not be treated as a morning warm up period.

**TEMPERING MODE** — In a vent or cooling mode, the rooftop may encounter a situation where the economizer at minimum position is sending cold outside air down the ductwork of the building. Therefore, it may be necessary to bring heat on to counter-effect this low supply-air temperature. This is referred to as the tempering mode.

**Setting up the System** — The relevant set points for Tempering are located at the local display under *Setpoints*:

ITEM	EXPANSION	RANGE	UNITS	CCN POINT	DEFAULT
T.PRG	Tempering Purge SASP	-20-80	dF	TEMPPURG	50
T.CL	Tempering in Cool SASP	5-75	dF	TEMPCOOL	5
T.V.OCC	Tempering Vent Occ SASP	-20-80	dF	TEMPVOCC	65
T.V.UN	Tempering Vent Unocc. SASP	-20-80	dF	TEMPVUNC	50

**Operation** — First, the unit must be in a vent mode, a low cool mode, or a high cool HVAC mode to be considered for a tempering mode. Secondly, the tempering mode is only allowed when the rooftop is configured for staged gas (**Configuration→HEAT→HT.CF=3**).

If the control is configured for staged gas, the control is in a vent, low cool, or high cool HVAC mode, and the rooftop control is in a situation where the economizer must maintain a minimum position, then the evaporator discharge temperature (EDT) will be monitored. If the EDT falls below a particular trip point then the tempering mode may be called out:

HVAC mode = “Tempering Vent”

HVAC mode = “Tempering LoCool”  
HVAC mode = “Tempering HiCool”

The decision making/selection process for the tempering trip set point is as follows:

- If an HVAC cool mode is in effect, then the vent trip point is **T.CL**.
- If in a pre-occupied purge mode (**Operating Modes** → **MODE** → **IAQ.P=ON**), then the trip point is **T.PRG**.
- If in an occupied mode (**Operating Modes** → **MODE** → **IAQ.P=ON**), then the trip point is **T.VOC**.
- For all other cases, the trip point is **T.V.UN**.

NOTE: The unoccupied economizer free cooling mode does not qualify as a HVAC cool mode as it is an energy saving feature and has its own OAT lockout already. The unoccupied free cooling mode (HVAC mode = Unocc. Free Cool) will override any unoccupied vent mode from triggering a tempering mode.

If OAT is above the chosen tempering set point, tempering will not be allowed. Additionally, tempering mode is locked out if any stages of mechanical cooling are present.

A minimum amount of time must pass before calling out any tempering mode. In effect, the EDT must fall below the trip point value  $-1^{\circ}$  F continuously for a minimum of 2 minutes. Also, at the end of a mechanical cooling cycle, there must be a minimum 10 minutes of delay allowed before considering tempering during vent mode in order to allow any residual cooling to dissipate from the evaporator coil.

If the above conditions are met, the algorithm is free to select the tempering mode (MODETEMP). If a tempering mode becomes active, the modulating heat source (staged gas) will attempt to maintain leaving-air temperature (LAT) at the tempering set point used to trigger the tempering mode. The technique for modulation of set point for staged gas and hydronic heat is the same as in a heat mode. More information regarding the operation of heating can be referenced in the Heating Control section.

Recovery from a tempering mode (MODETEMP) will occur when the EDT rises above the trip point. On any change in HVACMODE, the tempering routine will re-assess the tempering set point which may cause the control to continue or exit tempering mode.

**Static Pressure Control** — Variable air volume (VAV) air-conditioning systems must provide varying amounts of air to the conditioned space. As air terminals downstream of the unit modulate their flows, the unit must maintain control over the duct static pressure in order to accommodate the needs of the terminals and meet the varying combined airflow requirement.

The static pressure control routine is also used on CV units with VFD for staged air volume. The fan is controlled at discrete speeds through the VFD by the unit *ComfortLink* control based on the operating mode of the unit.

A 48/50AK,AY,A3,A5 unit equipped with a duct pressure control system is provided with a variable frequency drive (VFD) for the supply fan. The speed of the fan can be controlled directly by the *ComfortLink* controls. A transducer is used to measure duct static pressure. The signal from the transducer is received by the ECB-2 board and is then used in a PID control routine that outputs a 4 to 20 mA signal to the VFD.

Generally, only VAV systems utilize static pressure control. It is required because as the system VAV terminals modulate closed when less air is required, there must be a means of controlling airflow from the unit, thereby effectively preventing overpressurization and its accompanying problems.

A 48/50AJ,AW,A2,A4 unit can be equipped with a VFD for staged air volume control. The speed of the fan is controlled directly by the *ComfortLink* controls based on the operating

mode of the unit. A 4 to 20 mA signal is sent to the VFD to control the fan speed.

The four most fundamental configurations for most applications are **Configuration** → **SP** → **SP.CF**, which is the static pressure control type, **Configuration** → **SP** → **CV.FD**, used to indicate CV unit with VFD (staged air volume). **Configuration** → **SP** → **SP.S**, used to enable the static pressure sensor, and **Configuration** → **SP** → **SP.SP**, the static pressure set point to be maintained.

OPERATION — On VAV units equipped with a VFD and a proper static pressure sensor, when **SP.CF**, **SP.S** and **SP.SP** are configured, a PID routine periodically measures the duct static pressure and calculates the error from set point. This error is simply the duct static pressure set point minus the measured duct static pressure. The error becomes the basis for the proportional term of the PID. The routine also calculates the integral of the error over time, and the derivative (rate of change) of the error. A value is calculated as a result of this PID routine, and this value is then used to create an output signal used to adjust the VFD to maintain the static pressure set point.

Static pressure reset is the ability to force a lowering of the static pressure set point through an external control signal. The unit controls support this in two separate ways, through a 4 to 20 mA signal input wired to the unit's isolator board input terminals (third party control) or via CCN.

When employing the CCN, this feature uses the communications capabilities of VAV systems with ComfortID™ terminals under linkage. The system dynamically determines and maintains an optimal duct static pressure set point based on the actual load conditions in the space. This can result in a significant reduction in required fan energy by lowering the set point to only the level required to maintain adequate airflow throughout the system.

OPERATION — On CV units equipped with a VFD (Staged Air Volume) when **SP.CF**, **CV.FD**, **SP.FN** are configured, the *ComfortLink* control will control the speed of the supply fan based on the operating mode of the unit. The VFD speed setting points are **SP.MN**, **SP.MX**, **HT.VM**. When in LOW COOL mode and the compressor stage less than 50%, fan will be as **SP.MN** minimum speed. When in HIGH COOL, the fan will be at **SP.MX** maximum speed. In heating mode, the fan will operate at **SP.MX** maximum speed when the heating stage is 75% or greater and at **HT.VM** heating minimum speed when the heating stage is less than 75%. On units configured for two stage T'stat operation, the fan will be at **SP.MX** on a call for W2 and at **HT.VM** on a call for only W1.

SETTING UP THE SYSTEM — The options for static pressure control are found under the Local Display Mode **Configuration** → **SP**. See Table 75.

#### CAUTION

Failure to correctly configure **SP.CF** and **SP.FN** when operating in VFD Bypass mode will result in the indoor fan motor running continuously. Damage to unit could result.

**Static Pressure Configuration (SP.CF)** — This variable is used to configure the use of *ComfortLink* controls for static pressure control. There are the following options:

**0 (None)** — There will be no static pressure control by *ComfortLink* controls. This setting would be used for a constant volume (CV) application when static pressure control is not required or for a VAV application if there will be third-party control of the VFD. In this latter case, a suitable means of control must be field installed. This setting must be used on CV units with VFD (staged air volume).

Additionally, **SP.CF** must be set to 0 (None) when a unit is equipped with optional VFD bypass and is operating in Bypass

mode. Failure to change this configuration in Bypass mode will result in the indoor fan motor running continuously.

**I (VFD Control)** — This will enable the use of *ComfortLink* controls for static pressure control via a supply fan VFD.

**Constant Vol IDF ia VFD? (CV.FD)** — This variable enables the use of a CV unit with VFD for staged air volume control.

**Static Pressure Fan Control? (SP.FN)** — This is automatically set to Yes when **SP.CF** = 1 or when **CV.FD** is set to Yes. When the user would like the 4 to 20 mA output to energize the VFD, as opposed to the fan relay, **SP.FN** may be set to Yes when **SP.CF** = 0. When the control turns the fan ON, the control will send the **SP.MX** value of the 4 to 20 mA signal to the third party VFD control.

Additionally, **SP.FN** must be set to NO when the unit is equipped with optional VFD bypass and is operating in Bypass mode. Failure to change this configuration in bypass mode will result in the indoor fan motor running continuously.

**Static Pressure Sensor (SP.S)** — This variable enables the use of a supply duct static pressure sensor. This must be enabled to use *ComfortLink* controls for static pressure control. If using a third-party control for the VFD, this should be disabled. This is not used when **CV.FD** is set to Yes.

**Static Pressure Low Range (SP.LO)** — This is the minimum static pressure that the sensor will measure. For most sensors this will be 0 in. wg. The *ComfortLink* controls will map this value to a 4 mA sensor input.

**Static Pressure High Range (SP.HI)** — This is the maximum static pressure that the sensor will measure. Commonly this will be 5 in. wg. The *ComfortLink* controls will map this value to a 20 mA sensor input.

**Static Pressure Set Point (SP.SP)** — This is the static pressure control point. It is the point against which the *ComfortLink* controls compare the actual measured supply duct pressure for determination of the error that is used for PID control. Generally one would set **SP.SP** to the minimum value necessary for proper operation of air terminals in the conditioned space at all load conditions. Too high of a value will cause unnecessary fan motor power consumption at part load conditions and/or noise problems. Too low a value will result in insufficient airflow.

**VFD Minimum Speed (SP.MN)** — This is the minimum speed for the supply fan VFD. Typically the value is chosen to maintain a minimum level of ventilation.

**VFD Heating Minimum Speed (HT.V.M)** — This is the low speed setting for units in heating mode. The range is 75 to 100% with the default setting of 75%.

NOTE: Most VFDs have a built-in minimum speed adjustment which must be configured for 0% when using *ComfortLink* controls for static pressure control.

**VFD Maximum Speed (SP.MX)** — This is the maximum speed for the supply fan VFD. This is usually set to 100% when **CV.FD** = Yes, the range is 33 to 67% with the default setting of 67%.

**VFD Fire Speed Override (SP.FS)** — This is the speed that the supply fan VFD will use during the pressurization, evacuation and purge fire modes. This is usually set to 100%.

**Static Pressure Reset Configuration (SP.RS)** — This option is used to configure the static pressure reset function. When **SP.RS** = 0, there is no static pressure reset via an analog input.

If the outdoor air quality sensor is not configured (**Configuration** → **IAQ** → **IAQ.CF** → **OQ.A.C** = 0), then it is possible to use the outdoor air quality sensor location on the CEM board to perform static pressure reset via an external 4 to 20 mA input.

Configuring **SP.RS** = 1 provides static pressure reset based on this CEM 4 to 20 mA input and ranged from 0 to 3 in. wg. Wire the input to the CEM using TB6-11 and 12. When **SP.RS** = 2, there is static pressure reset based on RAT and defined by **SP.RT** and **SP.LM**. When **SP.RS** = 3, there is static pressure reset based on SPT and defined by **SP.RT** and **SP.LM**.

Setting **SP.RS** to 1, 2 or 3 will give the user the ability to reset from 0 to 3 in. wg of static pressure. The reset will apply to the supply static pressure set point. The static pressure reset function will only act to reduce the static pressure control point.

As an example, the static pressure reset input is measuring 6 mA, and is therefore resetting 2 mA (6 mA – 4 mA) of its 16 mA control range. The 4 to 20 mA range corresponds directly to the 0 to 3 in. wg of reset. Therefore 2 mA reset is  $2/16 * 3 \text{ in. wg} = 0.375 \text{ in. wg}$  of reset. If the static pressure set point (**SP.SP**) = 1.5 in. wg, then the static pressure control point for the system will be reset to  $1.5 - 0.375 = 1.125 \text{ in. wg}$ .

When **SP.RS** = 4, the static pressure reset function acts to provide direct VFD speed control where 4 mA = 0% speed and 20 mA = 100% (**SP.MN** and **SP.MX** will override). Note that **SP.CF** must be set to 1 (VFD Control), prior to configuring **SP.RS** = 4. Failure to do so could result in damage to ductwork due to overpressurization. This is the recommended approach if a third party wishes to control the variable speed supply fan. In effect, this represents a speed control signal “pass through” under normal operating circumstances. The *ComfortLink* control system overrides the third party signal for critical operation situations, most notably smoke and fire control.

**Static Pressure Reset Ratio (SP.RT)** — This option defines the reset ratio in terms of static pressure versus temperature. The reset ratio determines how much is the static pressure reduced for every degree below set point for RAT or SPT.

**Static Pressure Reset Limit (SP.LM)** — This option defines the maximum amount of static pressure reset that is allowed. This is sometimes called a “clamp.”

NOTE: Resetting static pressure via RAT and SPT is primarily a constant volume application which utilizes a VFD. The reasoning is that there is significant energy savings in slowing down a supply fan as opposed to running full speed with supply air reset. Maintaining the supply air set point and slowing down the fan has the additional benefit of working around dehumidification concerns.

**Static Pressure Reset Economizer Position (SPEC)** — This option effectively resets **ECONOMIN** to fully occupied ventilation position, to account for the drop in static pressure during static pressure reset control. The static pressure reset for the calculation cannot be larger than the supply air static set point (**SP.SP**).

The calculation is as follows:

(Static Pressure Reset/**SP.LM**) x (ECONOSPR – **ECONOMIN**)

As an example, the static pressure reset limit (**SP.LM**) = 0.75 in. wg. The current static pressure reset is set to 0.5 in. wg. The settings for **ECONOSPR** = 50% and **ECONOMIN** = 20%.

**Table 75 — Static Pressure Control Configuration**

ITEM	EXPANSION	RANGE	UNITS	CCN POINT	DEFAULT
<b>SP</b>	SUPPLY STATIC PRESS.CFG.				
<b>SP.CF</b>	Static Pres. VFD Control?	0, 1		STATICCFG	0*
<b>CV.FD</b>	Constant VOL IDF is VFD	Yes/No		CVIDFVFD	No
<b>SP.FN</b>	Static Pres. Fan Control?	Yes/No		STATPFAN	Yes*
<b>SP.S</b>	Static Pressure Sensor	Enable/Disable		SPSENS	Disable*
<b>SP.LO</b>	Static Press. Low Range	-10 - 0	in. W.C.	SP_LOW	0
<b>SP.HI</b>	Static Press. High Range	0 - 10	in. W.C.	SP_HIGH	5
<b>SP.SP</b>	Static Pressure Setpoint	0 - 5	in. W.C.	SPSP	1.5
<b>SP.MN</b>	VFD Minimum Speed	0 - 100	%	STATPMIN	20
<b>SP.MX</b>	VFD Maximum Speed	0 - 100†	%	STATPMAX	100**
<b>SP.FS</b>	VFD Fire Speed Override	0 - 100	%	STATPFSSO	100
<b>HT.V.M</b>	VFD Heating Minimum Speed	75-100	%	VFDHTMIN	75
<b>SP.RS</b>	Stat. Pres. Reset Config	0 - 4		SPRSTCFG	0
<b>SP.RT</b>	SP Reset Ratio (""/dF)	0 - 2.00		SPRRATIO	0.2
<b>SP.LM</b>	SP Reset Limit in iwc ("	0 - 2.00		SPRLIMIT	0.75
<b>SP.EC</b>	SP Reset Econo.Position	0 - 100	%	ECONOSPR	5
<b>S.PID</b>	STAT.PRESS.PID CONFIGS				
<b>SP.TM</b>	Static Press. PID Run Rate	1 - 200	sec	SPIDRATE	2
<b>SP.P</b>	Static Press. Prop. Gain	0 - 100		STATP_PG	20
<b>SP.I</b>	Static Press. Intg. Gain	0 - 50		STATP_IG	2
<b>SP.D</b>	Static Press. Derv. Gain	0 - 50		STATP_DG	0
<b>SP.SG</b>	Static Press. System Gain	0 - 50		STATP_SG	1.0

\* Some defaults are model number dependent.

† 33-67 when CV.FD = Yes.

\*\* 67 when CV.FD = Yes.

Therefore, the amount to add to the economizer's ECONOMIN configuration is:  $(0.5/0.75) \times (50-20) = 20\%$ . In effect, for the positioning of the economizer, ECONOMIN would now be replaced by ECONOMIN + 10%.

**Static Pressure PID Config (S.PID)** — Static pressure PID configuration can be accessed under this heading in the **Configuration** → **SP** submenu. Under most operating conditions the control PID factors will not require any adjustment and the factory defaults should be used. If persistent static pressure fluctuations are detected, small changes to these factors may improve performance. Decreasing the factors generally reduce the responsiveness of the control loop, while increasing the factors increase its responsiveness. Note the existing settings before making changes, and seek technical assistance from Carrier before making significant changes to these factors.

**Static Pressure PID Run Rate (S.PID → S.P.TM)** — This is the number of seconds between duct static pressure readings taken by the ComfortLink PID routine.

**Static Pressure Proportional Gain (S.PID → S.P.P)** — This is the proportional gain for the static pressure control PID control loop.

**Static Pressure Integral Gain (S.PID → S.P.I)** — This is the integral gain for the static pressure control PID control loop.

**Static Pressure Derivative Gain (S.PID → S.P.D)** — This is the derivative gain for the static pressure control PID control loop.

**Static Pressure System Gain (S.PID → S.P.SG)** — This is the system gain for the static pressure control PID control loop.

**STATIC PRESSURE RESET OPERATION** — The ComfortLink controls support the use of static pressure reset. The Linkage Master terminal monitors the primary air damper position of all the terminals in the system (done through LINKAGE with the new ComfortID™ air terminals).

The Linkage Master then calculates the amount of supply static pressure reduction necessary to cause the most open damper in the system to open more than the minimum value (60%) but not more than the maximum value (90% or negligible static pressure drop). This is a dynamic calculation, which occurs every two minutes when ever the system is operating.

The calculation ensures that the supply static pressure is always enough to supply the required airflow at the worst case terminal but never more than necessary, so that the primary air dampers do not have to operate with an excessive pressure drop (more than required to maintain the airflow set point of each individual terminal in the system).

As the system operates, if the most open damper opens more than 90%, the system recalculates the pressure reduction variable and the value is reduced. Because the reset value is subtracted from the controlling set point at the equipment, the pressure set point increases and the primary-air dampers close a little (to less than 90%). If the most open damper closes to less than 60%, the system recalculates the pressure reduction variable and the value is increased. This results in a decrease in the controlling set point at the equipment, which causes the primary-air dampers to open a little more (to greater than 60%).

The rooftop unit has the static pressure set point programmed into the CCN control. This is the maximum set point that could ever be achieved under any condition. To simplify the installation and commissioning process for the field, this system control is designed so that the installer only needs to enter a maximum duct design pressure or maximum equipment pressure, whichever is less. There is no longer a need to calculate the worst case pressure drop at design conditions and then hope that some intermediate condition does not require a higher supply static pressure to meet the load conditions. For example, a system design requirement may be 1.2 in. wg, the equipment may be capable of providing 3.0 in. wg and the supply duct is designed for 5.0 in. wg. In this case, the installer could enter 3.0 in. wg as the supply static pressure set point and allow the air terminal system to dynamically adjust the supply duct static pressure set point as required.

The system will determine the actual set point required delivering the required airflow at every terminal under the current load conditions. The set point will always be the lowest value under the given conditions. As the conditions and airflow set points at each terminal change throughout the operating period, the equipment static pressure set point will also change.



The CCN system must have access to a CCN variable (SPRESET which is part of the equipment controller). In the algorithm for static pressure control, the SPRESET value is always subtracted from the configured static pressure set point by the equipment controller. The SPRESET variable is always checked to be a positive value or zero only (negative values are limited to zero). The result of the subtraction of the SPRESET variable from the configured set point is limited so that it cannot be less than zero. The result is that the system will dynamically determine the required duct static pressure based on the actual load conditions currently in the space. This eliminates the need to calculate the design supply static pressure set point. This also saves the energy difference between the design static pressure set point and the required static pressure.

**Third Party 4 to 20 mA Input** — It is also possible to perform static pressure reset via an external 4 to 20 mA signal connected to the CEM board where 4 mA corresponds to 0 in. wg of reset and 20 mA corresponds to 3 in. wg of reset. The static pressure 4 to 20 mA input shares the same input as the analog OAQ sensor. Therefore, both sensors cannot be used at the same time. To enable the static pressure reset 4 to 20 mA sensor, set (*Configuration* → *SP* → *SP.RS*) to Enabled.

**RELATED POINTS** — These points represent static pressure control and static pressure reset inputs and outputs. See Table 76.

**Static Pressure mA (SP.M)** — This variable reflects the value of the static pressure sensor signal received by the *ComfortLink* controls. The value may be helpful in troubleshooting.

**Static Pressure mA Trim (SP.M.T)** — This input allows a modest amount of trim to the 4 to 20 mA static pressure transducer signal, and can be used to calibrate a transducer.

**Static Pressure Reset mA (SP.R.M)** — This input reflects the value of a 4 to 20 mA static pressure reset signal applied to TB6 terminals 11 and 12 on the CEM board, from a third party control system.

**Static Pressure Reset (SP.RS)** — This variable reflects the value of a static pressure reset signal applied from a CCN system. The means of applying this reset is by forcing the value of the variable SPRESET through CCN.

**Supply Fan VFD Speed (S.VFD)** — This output can be used to check on the actual speed of the VFD. This may be helpful in some cases for troubleshooting.

## Fan Status Monitoring

**GENERAL** — The A Series *ComfortLink* controls offer the capability to detect a failed supply fan through either a duct static pressure transducer or an accessory discrete switch. The fan status switch is an accessory that allows for the monitoring of a discrete switch, which trips above a differential pressure drop across the supply fan. For any unit with a factory-installed duct static pressure sensor, it is possible to measure duct pressure rise directly, which removes the need for a differential switch. All 48/50AK,AW,A3,A5 units with a factory-installed supply fan VFD will have the duct static pressure sensor as standard.

**SETTING UP THE SYSTEM** — The fan status monitoring configurations are located in *Configuration* → *UNIT*. See Table 77.

**Fan Stat Monitoring Type (SFS.M)** — This configuration selects the type of fan status monitoring to be performed.

- 0 - NONE — No switch or monitoring
- 1 - SWITCH — Use of the fan status switch
- 2 - SP RISE — Monitoring of the supply duct pressure.

**Fan Fail Shuts Down Unit (SFS.S)** — This configuration will configure the unit to shut down on a supply fan status fail or simply alert the condition and continue to run. When configured to YES, the control will shut down the unit if supply fan status monitoring fails and the control will also send out an alarm. If set to NO, the control will not shut down the unit if supply fan status monitoring fails but will send out an alert.

**SUPPLY FAN STATUS MONITORING LOGIC** — Regardless of whether the user is monitoring a discrete switch or is monitoring static pressure, the timing for both methods are the same and rely upon the configuration of static pressure control. The configuration that determines static pressure control is *Configuration* → *SP* → *SP.CF*. If this configuration is set to 0 (none), a fan failure condition must wait 60 continuous seconds before taking action. If this configuration is 1 (VFD), a fan failure condition must wait 3 continuous minutes before taking action.

If the unit is configured to monitor a fan status switch (*SFS.M* = 1), and if the supply fan commanded state does not match the supply fan status switch for 3 continuous minutes, then a fan status failure has occurred.

If the unit is configured for supply duct pressure monitoring (*SFS.M* = 2), then

- If the supply fan is requested ON and the static pressure reading is not greater than 0.2 in. wg for 3 continuous minutes, a fan failure has occurred.
- If the supply fan is requested OFF and the static pressure reading is not less than 0.2 in. wg for 3 continuous minutes, a fan failure has occurred.

**Dirty Filter Switch** — The unit can be equipped with a field-installed accessory dirty filter switch. The switch is located in the filter section. If a dirty filter switch is not installed, the switch input is configured to read “clean” all the time.

To enable the sensor for dirty filter monitoring set *Configuration* → *UNIT* → *SENS* → *FLT.S* to ENABLE. The state of the filter status switch can be read at *Inputs* → *GEN.I* → *FLT.S*. See Table 78.

**Table 77 — Fan Status Monitoring Configuration**

ITEM	EXPANSION	RANGE	CCN POINT
<i>SFS.S</i>	Fan Fail Shuts Down Unit	Yes/No	SFS_SHUT
<i>SFS.M</i>	Fan Stat Monitoring Type	0 - 2	SFS_MON

**Table 78 — Dirty Filter Switch Points**

ITEM	EXPANSION	RANGE	CCN POINT
<i>Configuration</i> → <i>UNIT</i> → <i>SENS</i> → <i>FLT.S</i>	Filter Stat.Sw.Enabled ?	Enable/Disable	FLTS_ENA
<i>Inputs</i> → <i>GEN.I</i> → <i>FLT.S</i>	Filter Status Input	DRTY/CLN	FLTS

**Table 76 — Static Pressure Reset Related Points**

ITEM	EXPANSION	RANGE	UNITS	CCN POINT	DEFAULT
<b>Inputs</b>					
→ 4-20 → <i>SP.M</i>	Static Pressure mA	4-20	mA	SP_MA	
→ 4-20 → <i>SP.M.T</i>	Static Pressure mA Trim	-2.0 - +2.0	mA	SPMATRIM	
→ 4-20 → <i>SP.R.M</i>	Static Pressure Reset mA	4-20	mA	SPRST_MA	0.0
→ <i>RSET</i> → <i>SP.RS</i>	Static Pressure Reset	0.0-3.0	in. wg	SPRESET	0.0
<b>Outputs</b>					
→ <i>Fans</i> → <i>S.VFD</i>	Supply Fan VFD Speed	0-100	%	SFAN_VFD	



Monitoring of the filter status switch is disabled in the Service Test mode and when the supply fan is not commanded on. If the fan is on and the unit is not in a test mode and the filter status switch reads “dirty” for 2 continuous minutes, an alert is generated. Recovery from this alert is done through a clearing of all alarms or after cleaning the filter and the switch reads “clean” for 30 seconds.

NOTE: The filter switch should be adjusted to allow for the operating cfm and the type of filter. Refer to the accessory installation instructions for information on adjusting the switch.

**Economizer** — The economizer control is used to manage the outside and return air dampers of the unit to provide ventilation air as well as free cooling based on several configuration options. This section contains a description of the economizer and its ability to provide free cooling. See the section on Indoor Air Quality Control on page 67 for more information on setting up and using the economizer to perform demand controlled ventilation (DCV). See the Third Party Control section for a description on how to take over the operation of the economizer through external control.

The economizer system also permits this unit to perform smoke control functions based on external control switch inputs. Refer to the Smoke Control Modes section for detailed discussions.

Economizer control can be based on automatic control algorithms using unit-based set points and sensor inputs. This economizer control system can also be managed through external logic systems.

The economizer system is a factory-installed option. This unit can also have the following devices installed to enhance economizer control:

- Outside air humidity sensor
- Return air humidity sensor

NOTE: All these options require the controls expansion module (CEM).

**SETTING UP THE SYSTEM** — The economizer configuration options are under the Local Display Mode **Configuration** → **ECON**. See Table 79.

**Economizer Installed? (EC.EN)** — If an economizer is not installed or is to be completely disabled then the configuration option **EC.EN** should be set to No. Otherwise in the case of an installed economizer, this value must be set to Yes.

**Economizer Minimum Position (EC.MN)** — The configuration option **EC.MN** is the economizer minimum position. See the section on indoor air quality for further information on how to reset the economizer further to gain energy savings and to more carefully monitor IAQ problems.

**Economizer Maximum Position (EC.MX)** — The upper limit of the economizer may be limited by setting **EC.MX**. This value defaults to 98% to avoid problems associated with slight changes in the economizer damper’s end stop over time. Typically this will not need to be adjusted.

**Economizer Trim for Sum Z? (E.TRM)** — Sum Z is the adaptive cooling control algorithm used for multiple stages of mechanical cooling capacity. The configuration option, **E.TRM** is typically set to Yes, and allows the economizer to modulate to the same control point (Sum Z) that is used to control capacity staging. The advantage is lower compressor cycling coupled with tighter temperature control. Setting this option to No will cause the economizer, if it is able to provide free cooling, to open to the Economizer Max. Position (**EC.MX**) during mechanical cooling.

**ECONOMIZER OPERATION** — There are four potential elements which are considered concurrently which determine whether the economizer is able to provide free cooling:

1. Dry bulb changeover (outside-air temperature qualification)
2. Economizer switch (discrete control input monitoring)

3. Economizer changeover select (**E.SEL** economizer changeover select configuration option)
4. Outdoor dewpoint limit check (requires an installed outdoor relative humidity sensor installed)

**Dry Bulb Changeover (OAT.L)** — Outside-air temperature may be viewed under **Temperatures** → **AIR.T** → **OAT**. The control constantly compares its outside-air temperature reading against the high temperature OAT lockout (**OAT.L**). If the temperature reads above **OAT.L**, the economizer will not be allowed to perform free cooling.

**Economizer Switch (EC.SW)** — The function of this switch is determined by **Configuration** → **ECON** → **EC.SW**. The state of the corresponding economizer input can be viewed under **Inputs** → **GEN.I** → **E.SW**.

When set to **EC.SW = 0**, the switch is disabled. When set to **EC.SW = 1**, the economizer switch functions to enable/disable the economizer. When set to **EC.SW = 2**, the switch functions as an IAQ override switch. This functions just like the discrete IAQ input **Inputs** → **AIR.Q** → **IAQ.I** when **Configuration** → **IAQ** → **AQ.CF** → **IQ.I.C=2** (IAQ Discrete Override). See the Indoor Air Quality Control section for more information.

When **Configuration** → **ECON** → **EC.SW=1** and **Inputs** → **GEN.I** → **E.SW = No**, free cooling will not be allowed.

**Economizer Control Type (E.TYP)** — This configuration should not be changed.

**Economizer Changeover Select (E.SEL)** — The control is capable of performing any one of the following changeover types in addition to both the dry bulb lockout and the external switch enable input:

- |                  |                                  |
|------------------|----------------------------------|
| <b>E.SEL = 0</b> | none                             |
| <b>E.SEL = 1</b> | Differential Dry Bulb Changeover |
| <b>E.SEL = 2</b> | Outdoor Enthalpy Changeover      |
| <b>E.SEL = 3</b> | Differential Enthalpy Changeover |

**Differential Dry Bulb Changeover** — As both return air and outside air temperature sensors are installed as standard on these units, the user may select this option, **E.SEL = 1**, to perform a qualification of return and outside air in the enabling and disabling of free cooling. If this option is selected and outside-air temperature is greater than return-air temperature, free cooling will not be allowed.

**Outdoor Enthalpy Changeover** — This option should be used in climates with higher humidity conditions. The A Series control can use an enthalpy switch or enthalpy sensor, or the standard installed outdoor dry bulb sensor and an accessory relative humidity sensor to calculate the enthalpy of the air.

Setting **Configuration** → **ECON** → **E.SEL = 2** requires that the user configure **Configuration** → **ECON** → **O.A.E.C**, the Outdoor Enthalpy Changeover Select, and install an outdoor relative humidity sensor. Once the sensor is installed, enable **Configuration** → **ECON** → **ORH.S**, the outdoor relative humidity sensor configuration option.

If the user selects one of the Honeywell curves, A,B,C or D, then **O.A.E.C** options 1-4 should be selected. See Fig. 10 for a diagram of these curves on a psychrometric chart.

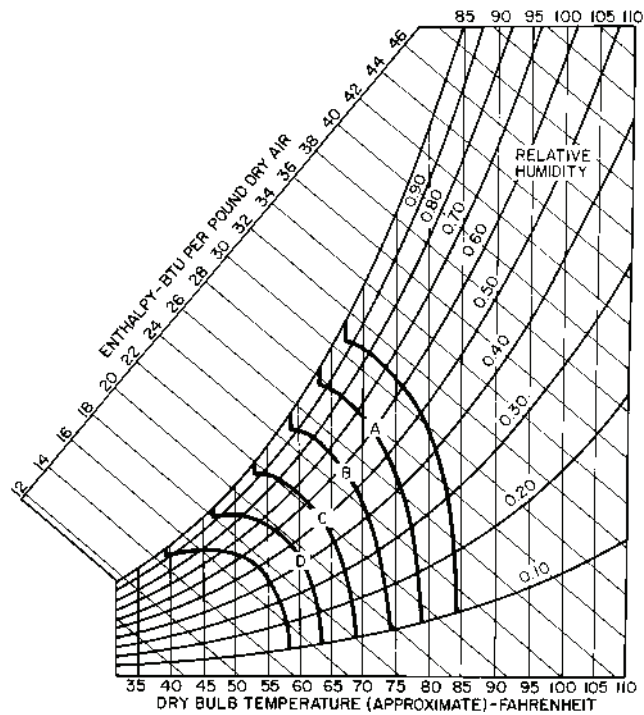
- |                    |                       |
|--------------------|-----------------------|
| <b>O.A.E.C = 1</b> | Honeywell A Curve     |
| <b>O.A.E.C = 2</b> | Honeywell B Curve     |
| <b>O.A.E.C = 3</b> | Honeywell C Curve     |
| <b>O.A.E.C = 4</b> | Honeywell D Curve     |
| <b>O.A.E.C = 5</b> | custom enthalpy curve |

If the user selects **O.A.E.C = 5**, a direct comparison of outdoor enthalpy versus an enthalpy set point is done. This outdoor enthalpy set point limit is configurable, and is called **Configuration** → **ECON** → **O.A.EN**.

Depending on what **Configuration** → **ECON** → **O.A.E.C** is configured for, if the outdoor enthalpy exceeds the Honeywell

curves or the outdoor enthalpy compare value (**Configuration** → **ECON** → **OA.EN**), then free cooling will not be allowed.

**Differential Enthalpy Changeover** — This option compares the outdoor-air enthalpy to the return air enthalpy and chooses the option with the lowest enthalpy. This option should be used in climates with high humidity conditions. This option uses both humidity sensors and dry bulb sensors to calculate the enthalpy of the outdoor and return air. An accessory outdoor air humidity sensor (**ORH.S**) and return air humidity sensor (**RRH.S**) are used. The outdoor air relative humidity sensor config (**ORH.S**) and return air humidity sensor config (**Configuration** → **UNIT** → **SENS** → **RRH.S**) must be enabled.



CONTROL CURVE	CONTROL POINT (approx Deg) AT 50% RH
A	73
B	68
C	63
D	58

**Fig. 10 — Psychrometric Chart for Enthalpy Control**

**Outdoor Dewpoint Limit Check** — If an outdoor relative humidity sensor is installed, then the control is able to calculate the outdoor air dewpoint temperature and will compare this temperature against the outside air dewpoint temperature limit configuration (**Configuration** → **ECON** → **O.DEW**). If the outdoor air dewpoint temperature is greater than **O.DEW**, then free cooling will not be allowed. Figure 11 shows a horizontal limit line in the custom curve of the psychrometric chart. This is the outdoor air dewpoint limit boundary.

**Custom Psychrometric Curves** — Refer to the psychrometric chart and the standard Honeywell A-D curves in Fig. 10. The curves start from the bottom and rise vertically, angle to the left and then fold over. This corresponds to the limits imposed by dry bulb changeover, outdoor enthalpy changeover and outdoor dewpoint limiting respectively. Therefore, it is now possible to create any curve desired with the addition of one outdoor relative humidity sensor and the options for changeover now available. See Fig. 11 for an example of a custom curve constructed on a psychrometric chart.

**UNOCCUPIED ECONOMIZER FREE COOLING** — This Free Cooling function is used to start the supply fan and use the economizer to bring in outside air when the outside temperature is cool enough to pre-cool the space. This is done to delay the need for mechanical cooling when the system enters the occupied period. This function requires the use of a space temperature sensor.

When configured, the economizer will modulate during an unoccupied period and attempt to maintain space temperature to the occupied cooling set point. Once the need for cooling has been satisfied during this cycle, the fan will be stopped.

Configuring the economizer for Unoccupied Economizer Free Cooling is done in the **UEFC** group. There are three configuration options, **FC.CF**, **FC.TM** and **FC.LO**.

**Unoccupied Economizer Free Cooling Configuration (FC.CF)** — This option is used to configure the type of unoccupied economizer free cooling control that is desired.

- 0 = disable unoccupied economizer free cooling
- 1 = perform unoccupied economizer free cooling as available during the entire unoccupied period.
- 2 = perform unoccupied economizer free cooling as available, **FC.TM** minutes before the next occupied period.

**Unoccupied Economizer Free Cooling Time Configuration (FC.TM)** — This option is a configurable time period, prior to the next occupied period, that the control will allow unoccupied economizer free cooling to operate. This option is only applicable when **FC.CF** = 2.

**Table 79 — Economizer Configuration Table**

ITEM	EXPANSION	RANGE	UNITS	CCN POINT	DEFAULT
<b>EC.EN</b>	Economizer Installed?	Yes/No		ECON_ENA	Yes
<b>EC.MN</b>	Economizer Min.Position	0 - 100	%	ECONOMIN	5
<b>EC.MX</b>	Economizer Max.Position	0 - 100	%	ECONOMAX	98
<b>E.TRM</b>	Economzr Trim For SumZ ?	Yes/No		ECONTRIM	Yes
<b>E.SEL</b>	Econ ChangeOver Select	0 - 3		ECON_SEL	0
<b>OA.E.C</b>	OA Enthalpy ChgOvr Selct	1 - 5		OAEC_SEL	4
<b>OA.EN</b>	Outdr.Enth Compare Value	18 - 28		OAEN_CFG	24
<b>OAT.L</b>	High OAT Lockout Temp	-40 - 120	dF	OAT_LOCK	60
<b>O.DEW</b>	OA Dewpoint Temp Limit	50 - 62	dF	OADEWCFG	55
<b>ORH.S</b>	Outside Air RH Sensor	Enable/Disable		OARHSENS	Disable
<b>E.TYP</b>	Economizer Control Type	1 - 3		ECON_CTL	1
<b>EC.SW</b>	Economizer Switch Config	0 - 2		ECOSWCFG	0
<b>E.CFG</b>	ECON.OPERATION CONFIGS				
<b>E.P.GN</b>	Economizer Prop.Gain	0.7 - 3.0		EC_PGAIN	1
<b>E.RNG</b>	Economizer Range Adjust	0.5 - 5	^F	EC_RANGE	2.5
<b>E.SPD</b>	Economizer Speed Adjust	0.1 - 10		EC_SPEED	0.75
<b>E.DBD</b>	Economizer Deadband	0.1 - 2	^F	EC_DBAND	0.5
<b>UEFC</b>	UNOCC.ECON.FREE COOLING				
<b>FC.CF</b>	Unoc Econ Free Cool Cfg	0-2		UEFC_CFG	0
<b>FC.TM</b>	Unoc Econ Free Cool Time	0 - 720	min	UEFCTIME	120
<b>FC.LO</b>	Un.Ec.Free Cool OAT Lock	40 - 70	dF	UEFCNTLO	50

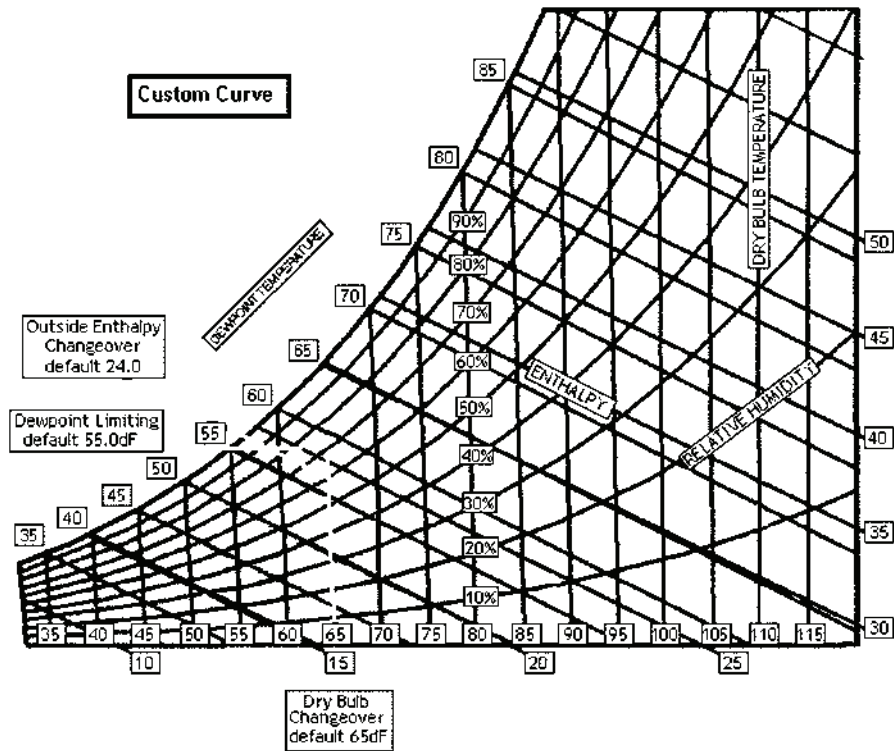


Fig. 11 — Custom Changeover Curve Example

Unoccupied Economizer Free Cooling Outside Lockout Temperature (FC.L.O) — This configuration option allows the user to select an outside-air temperature below which unoccupied free cooling is not allowed. This is further explained in the logic section.

Unoccupied Economizer Free Cooling Logic — The following qualifications that must be true for unoccupied free cooling to operate:

- Unit configured for an economizer
- Space temperature sensor enabled and sensor reading within limits
- Unit is in the unoccupied mode
- *FC.CF* set to 1 or *FC.CF* set to 2 and control is within *FC.TM* minutes of the next occupied period
- Not in the Temperature Compensated Start Mode
- Not in a cooling mode
- Not in a heating mode
- Not in a tempering mode
- Outside-air temperature sensor reading within limits
- Economizer would be allowed to cool if the fan was requested and in a cool mode
- $OAT > FC.L.O$  (1.0° F hysteresis applied)
- Unit not in a fire smoke mode
- No fan failure when configured to for unit to shut down on a fan failure

If all of the above conditions are satisfied:

Unoccupied Economizer Free Cooling will start when both of the following conditions are true:

$$\{SPT > (OCSP + 2)\} \text{ AND } \{SPT > (OAT + 8)\}$$

The Unoccupied Economizer Free Cooling Mode will stop when either of the following conditions are true:

$$\{SPT < OCSP\} \text{ OR } \{SPT < (OAT + 3)\}$$

where SPT = Space Temperature and OCSP = Occupied Cooling Set Point.

When the Unoccupied Economizer Free Cooling mode is active, the supply fan is turned on and the economizer damper modulated to control to the supply air set point (*Setpoints* → *SASP*) plus any supply air reset that may be applied (*Inputs* → *RSET* → *S.A.S.R*).

ECONOMIZER OPERATION CONFIGURATION — The configuration items in the *E.CFG* menu group affect how the economizer modulates when attempting to follow an economizer cooling set point. Typically, they will not need adjustment. In fact, it is strongly advised not to adjust these configuration items from their default settings without first consulting a service engineering representative.

In addition, the economizer cooling algorithm is designed to automatically slow down the economizer actuator's rate of travel as outside air temperature decreases.

ECONOMIZER DIAGNOSTIC HELP — Because there are so many conditions which might disable the economizer from being able to provide free cooling, the control has a display table to identify these potentially disabling sources. The user can check *ACTV*, the "Economizer Active" flag. If this flag is set to Yes there is no reason to check *DISA* (Economizer Disabling Conditions). If the flag is set to No, this means that at least one or more of the flags under the group *DISA* are set to Yes and the user can discover what is preventing the economizer from performing free cooling by checking the table.

The economizer's reported and commanded positions are also viewable, as well as outside air temperature, relative humidity, enthalpy and dew point temperature.

The following information can be found under the Local Display Mode *Run Status* → *ECON*. See Table 80.

Economizer Control Point Determination Logic — Once the economizer is allowed to provide free cooling, the economizer must determine exactly what set point it should try to maintain. The set point the economizer attempts to maintain when "free cooling" is located at *Run Status* → *VIEW* → *EC.C.P*. This is the economizer control point.

The control selects set points differently, based on the control type of the unit. This control type can be found at *Configuration* → *UNIT* → *C.TYP*. There are 6 types of control.

- |                  |                     |
|------------------|---------------------|
| <i>C.TYP</i> = 1 | VAV-RAT             |
| <i>C.TYP</i> = 2 | VAV-SPT             |
| <i>C.TYP</i> = 3 | TSTAT Multi-Staging |
| <i>C.TYP</i> = 4 | TSTAT 2 Stage       |

**C.TYP** = 5 SPT Multi-Staging  
**C.TYP** = 6 SPT 2 Stage

If the economizer is not allowed to do free cooling, then **EC.C.P** = 0.

If the economizer is allowed to do free cooling and the Unoccupied Free Cooling Mode is ON, then **EC.C.P** = **Setpoints** → **SASP** + **Inputs** → **RSET** → **SA.S.R.**

If the economizer is allowed to do free cooling and the Dehumidification mode is ON, then **EC.C.P** = the Cooling Control Point (**Run Status** → **VIEW** → **CL.C.P**).

If the **C.TYP** is either 4 or 6, and the unit is in a cool mode, then

If Stage = 0 **EC.C.P** = the Cooling Control Point (**Run Status** → **VIEW** → **CL.C.P**)

If Stage = 1 53.0 + economizer suction pressure reset (see below)

If Stage = 2 48.0 + economizer suction pressure reset (see below)

NOTE: To check the current cooling stage go to **Run Status** → **Cool** → **CUR.S.**

If the **C.TYP** is either 1,2,3 or 5, and the unit is in a cool mode, then **EC.C.P** = the Cooling Control Point (**Run Status** → **VIEW** → **CL.C.P**).

**Economizer Suction Pressure Reset for Two-Stage Cooling** — If the unit's control type is set to either 2-stage thermostat or 2-stage space temperature control, then there is no cooling control point. Stages 1 and 2 are brought on based on demand, irrespective of the evaporator discharge temperature. In this case, the economizer monitors suction pressure and resets the economizer control point accordingly in order to protect the unit from freezing. For those conditions when the economizer opens up fully but is not able to make set point, and then a compressor comes on, it is conceivable that the coil might freeze. This can be indirectly monitored by checking suction pressure. Rather than fail a circuit, the control will attempt to protect the unit by resetting the economizer control point until the suction pressure rises out of freezing conditions.

If either circuit's suction pressure drops to within 5 psig of the low suction pressure trip point, the control will start adding reset to the economizer control point if it is active. It will be possible to reset the control point upwards, 10 degrees (2 degrees per psig), between the low suction pressure trip point of 52 psig for 48/50AJ,AK,AW,AY units or 93 psig for 48/50A2,A3,A4,A5 units. If this does not work, and if the suction pressure drops below the trip point, then the control will further reset the control point 1 degree every 15 seconds up to a

maximum of 10 degrees. The resulting effect will be to warm up the mixed air entering the evaporator, thereby raising the suction pressure.

**Building Pressure Control** — The building pressure control sequence provides control of the pressure in the building through the modulating flow rate function of the modulating power exhaust option. This function also provides control of the constant volume 2-stage power exhaust option.

**BUILDING PRESSURE CONFIGURATION** — The building pressure configurations are found at the local display under **Configuration** → **BP**. See Table 81.

**Building Pressure Config (BPCF)** — This configuration selects the type of building pressure control.

- **BPCF** = 0, No building pressure control
- **BPCF** = 1, constant volume two-stage power exhaust based on economizer position
- **BPCF** = 2, multiple stage building pressure control based on a building pressure sensor
- **BPCF** = 3, VFD building pressure control based on a building pressure sensor

**Building Pressure PID Run Rate (BPRT)** — This configuration selects the run time of the PID algorithm. This configuration is only active when **BPCF** = 3. It is recommended that this value not be changed without guidance from Service Engineering.

**Building Pressure Proportional Gain (BPP)** — This configuration selects the proportional gain of the PID algorithm. This configuration is only active when **BPCF** = 3. It is recommended that this value not be changed without guidance from Service Engineering.

**Building Pressure Integral Gain (BPI)** — This configuration selects the integral gain of the PID algorithm. This configuration is only active when **BPCF** = 3. It is recommended that this value not be changed without guidance from Service Engineering.

**Building Pressure Derivative Gain (BPD)** — This configuration selects the derivative gain of the PID algorithm. This configuration is only active when **BPCF** = 3. It is recommended that this value not be changed without guidance from Service Engineering.

**Building Pressure Set Point Offset (BP.SO)** — This configuration is the value below the building pressure set point to which the building pressure must fall in order to turn off power exhaust control. This configuration is only active when **BPCF** = 3.

**Building Pressure Minimum Speed (BPMN)** — This configuration is the minimum allowed VFD speed during building pressure control. This configuration is only active when **BPCF** = 3.

**Table 80 — Economizer Run Status Table**

ITEM	EXPANSION	RANGE	UNITS	CCN POINT	WRITE STATUS
<b>ECN.P</b>	Economizer Act.Curr.Pos.	0-100	%	ECONOPOS	
<b>ECN.C</b>	Economizer Act.Cmd.Pos.	0-100	%	ECONOCMD	forcible
<b>ACTV</b>	Economizer Active ?	YES/NO		EACTIVE	
<b>DISA</b>	ECON DISABLING CONDITIONS				
<b>UNAV</b>	Econ Act. Unavailable?	YES/NO		ECONUNAV	
<b>R.EC.D</b>	Remote Econ. Disabled?	YES/NO		ECONDISA	
<b>DBC</b>	DBC - OAT Lockout?	YES/NO		DBC_STAT	
<b>DEW</b>	DEW - OA Dewpt.Lockout?	YES/NO		DEW_STAT	
<b>DDBC</b>	DDBC- OAT > RAT Lockout?	YES/NO		DDBCSTAT	
<b>OAEC</b>	OAEC- OA Enth Lockout?	YES/NO		OAECSTAT	
<b>DEC</b>	DEC - Diff.Enth.Lockout?	YES/NO		DEC_STAT	
<b>EDT</b>	EDT Sensor Bad?	YES/NO		EDT_STAT	
<b>OAT</b>	OAT Sensor Bad ?	YES/NO		OAT_STAT	
<b>FORC</b>	Economizer Forced ?	YES/NO		ECONFORC	
<b>SFON</b>	Supply Fan Not On 30s ?	YES/NO		SFONSTAT	
<b>CLOF</b>	Cool Mode Not In Effect?	YES/NO		COOL_OFF	
<b>OAQL</b>	OAQ Lockout in Effect ?	YES/NO		OAQLOCKD	
<b>HELD</b>	Econ Recovery Hold Off?	YES/NO		ECONHELD	
<b>DH.DS</b>	Dehumid. Disabled Econ.?	YES/NO		DHDISABL	
<b>O.AIR</b>	OUTSIDE AIR INFORMATION				
<b>OAT</b>	Outside Air Temperature		dF	OAT	forcible
<b>OA.RH</b>	Outside Air Rel. Humidity		%	OARH	forcible
<b>OA.E</b>	Outside Air Enthalpy			OAE	
<b>OA.D.T</b>	Outside Air Dewpoint Temp		dF	OAEWTMP	

**Building Pressure Maximum Speed (BP.MX)** — This configuration is the maximum allowed VFD speed during building pressure control. This configuration is only active when **BP.CF = 3**.

**VFD Fire Speed (BP.FS)** — This configuration is the VFD speed override when the control is in the purge or evacuation smoke control modes. This configuration is only active when **BP.CF = 3**.

**Power Exhaust Motors (BP.MT)** — This configuration is machine dependent and instructs the building pressure control algorithm as to whether the unit has 4 or 6 motors to control. The motors are controlled by three power exhaust relays A, B, and C. These relay outputs are located at the local display under **Outputs → FANS → PE.A,B,C**.

The following table illustrates the number of motors each relay is in control of based on **BP.MT**:

<b>BP.MT</b>	<b>PE_A Relay</b>	<b>PE_B Relay</b>	<b>PE_C Relay</b>
<b>1 (4 motors)</b>	1 Motor	2 Motors	1 Motor
<b>2 (6 motors)</b>	1 Motor	2 Motors	3 Motors

**Building Pressure Sensor (BP.S)** — This configuration allows the reading of a building pressure sensor when enabled. This is automatically enabled when **BP.CF = 2** or **3**.

**Building Pressure (+/-) Range (BP.R)** — This configuration establishes the range in in. wg that a 4 to 20 mA sensor will be scaled to. The control only allows sensors that measure both positive and negative pressure.

**Building Pressure SETP (BP.SP)** — This set point is the building pressure control set point. If the unit is configured for modulating building pressure control, then this is the set point that the control will control to.

**Power Exhaust on Setp.1 (BP.P1)** — When configured for building pressure control type **BP.CF = 1** (constant volume two-stage control), the control will turn on the first power exhaust fan when the economizer's position exceeds this set point.

**Power Exhaust on Setp.1 (BP.P2)** — When configured for building pressure control type **BP.CF = 1** (constant volume two-stage control), the control will turn on the second power exhaust fan when the economizer's position exceeds this set point.

**Modulating PE Algorithm Select (BP.SL)** — This configuration selects the algorithm used to step the power exhaust stages. This must be set to 1 at all times. The other selections are not used.

**Building Pressure PID Evaluation Time (BP.TM)** — This configuration is the run time rate of the multiple stage (modulating) power exhaust algorithm (**BP.CF=2**).

**Building Pressure Threshold Adjustment (BP.ZG)** — This configuration is not used. It currently has no effect on building pressure control.

**High Building Pressure Level (BP.HP)** — This configuration is the threshold level above the building pressure set point used to control stages of power exhaust when **BP.SL=1**.

**Low Building Pressure Level (BP.LP)** — This configuration is the threshold level below the building pressure set point used to control stages of power exhaust when **BP.SL=1**.

**CONSTANT VOLUME 2-STAGE CONTROL (BP.CF = 1) OPERATION** — Two exhaust fan relays will be turned on and off based on economizer position. The two trip set points are **BP.P1** and **BP.P2**. If the economizer is greater than or equal to **BP.P1**, then power exhaust stage 1 is requested and a 60-second timer is initialized. If the economizer is 5% below the **BP.P1**, then power exhaust stage 1 is turned off. Also, if the economizer position is less than **BP.P1** and the 60-second timer has expired, power exhaust stage 1 is turned off. The same logic applies to the second power exhaust stage, except the **BP.P2** trip point is monitored. If the economizer position is greater than or equal to **BP.P2**, then power exhaust stage 2 is energized and a 60-second timer is initialized. If the economizer is 5% below the **BP.P2** the second power exhaust stage turned off. If the economizer is less than **BP.P2** and the 60-second timer has expired, second stage power exhaust is turned off.

For **BP.CF=1**, the Table 82 illustrates the power exhaust stages 1 and 2, relay combinations based upon **Configuration → BP.MT** (4 or 6 motors).

**MULTIPLE POWER EXHAUST STAGE BUILDING PRESSURE CONTROL (BP.CF = 2) OPERATION** — Building pressure control is active whenever the supply fan is running. The control algorithm to be used (**BP.SL=1**) is a timed threshold technique for bringing stages of power exhaust on and off.

The number of power exhaust stages available for this control algorithm is a function of the number of motors it supports. This number of motors is defined by the **Configuration → BP → BP.MT** configuration. Table 83 illustrates the staging tables for this control algorithm based on **BP.MT**.

The following configurations are used in the controlling of building pressure with this algorithm:

- **Configuration → BP → B.CFG → BP.HP** (building pressure high threshold level)
- **Configuration → BP → B.CFG → BP.LP** (building pressure low threshold level)
- **Configuration → BP → B.CFG → BP.TM** (building pressure timer)

This control function is allowed to add or select power exhaust stages at any time, except that a delay time must expire after a stage is added or subtracted. Any time a stage change is made, a timer is started which delays staging for  $10 * BP.TM$  seconds. The default for **BP.TM** is 1, therefore the delay between stage changes is set to 10 seconds.

The logic to add or subtract a stage of power exhaust is as follows:

- If building pressure (**Pressures → AIR.P → BP**) is greater than the building pressure set point (**Configuration → BP → BP.SP**) plus the building pressure high threshold level (**Configuration → BP → B.CFG → BP.HP**) add a stage of power exhaust.

**Table 81 — Building Pressure Configuration**

ITEM	EXPANSION	RANGE	UNITS	CCN POINT	DEFAULT
<b>BP</b>	BUILDING PRESS. CONFIG				
<b>BP.CF</b>	Building Press. Config	0-3		BLDG_CFG	0*
<b>BP.RT</b>	Bldg.Pres.PID Run Rate	5-120	sec	BPIDRATE	10
<b>BP.P</b>	Bldg. Press. Prop. Gain	0-5		BLDGP_PG	0.5
<b>BP.I</b>	Bldg.Press.Integ.Gain	0-2		BLDGP_IG	0.5
<b>BP.D</b>	Bldg.Press.Deriv.Gain	0-5		BLDGP_DG	0.3
<b>BP.SO</b>	BP Setpoint Offset	0.0 - 0.5	"H2O	BPSO	0.05
<b>BP.MN</b>	BP VFD Minimum Speed	0-100	%	BLDGPMIN	10
<b>BP.MX</b>	BP VFD Maximum Speed	0-100	%	BLDGPMAX	100
<b>BP.FS</b>	VFD/Act. Fire Speed/Pos.	0-100	%	BLDGPFSO	100
<b>BP.MT</b>	Power Exhaust Motors	1-2		PWRM	1*
<b>BP.S</b>	Building Pressure Sensor	Enable/Dsable		BPSENS	Dsable*
<b>BP.R</b>	Bldg Press (+/-) Range	0 - 1.00	"H2O	BP_RANGE	0.25
<b>BP.SP</b>	Building Pressure Setp.	-0.25 -> 0.25	"H2O	BPSP	0.05
<b>BP.P1</b>	Power Exhaust On Setp.1	0 - 100	%	PES1	35
<b>BP.P2</b>	Power Exhaust On Setp.2	0 - 100	%	PES2	75
<b>B.CFG</b>	BP ALGORITHM CONFIGS				
<b>BP.SL</b>	Modulating PE Alg. Slct.	1-3		BPSELECT	1
<b>BP.TM</b>	BP PID Evaluation Time	0 - 10	min	BPPERIOD	1
<b>BP.ZG</b>	BP Threshold Adjustment	0.1 - 10.0	"H2O	BPZ_GAIN	1
<b>BP.HP</b>	High BP Level	0 - 1.000	"H2O	BPHPLVL	0.05
<b>BP.LP</b>	Low BP Level	0 - 1.000	"H2O	BPLPLVL	0.04

\*Some configurations are machine dependent.

**Table 82 — Power Exhaust Staging (BP.CF = 1)**

<b>BP.MT = 1 (4 motors)</b>	<b>PE.A</b>	<b>PE.B</b>	<b>PE.C</b>
Power Exhaust Stage 0	OFF	OFF	OFF
Power Exhaust Stage 1	OFF	ON	OFF
Power Exhaust Stage 2	ON	ON	ON
<b>BP.MT = 2 (6 motors)</b>	<b>PE.A</b>	<b>PE.B</b>	<b>PE.C</b>
Power Exhaust Stage 0	OFF	OFF	OFF
Power Exhaust Stage 1	OFF	OFF	ON
Power Exhaust Stage 2	ON	ON	ON

**Table 83 — Power Exhaust Staging (BP.CF = 2)**

<b>BP.MT = 1 (4 motors)</b>	<b>PE.A</b>	<b>PE.B</b>	<b>PE.C</b>
Power Exhaust Stage 0	OFF	OFF	OFF
Power Exhaust Stage 1	ON	OFF	OFF
Power Exhaust Stage 2	OFF	ON	OFF
Power Exhaust Stage 3	ON	ON	OFF
Power Exhaust Stage 4	ON	ON	ON
<b>BP.MT = 2 (6 motors)</b>	<b>PE.A</b>	<b>PE.B</b>	<b>PE.C</b>
Power Exhaust Stage 0	OFF	OFF	OFF
Power Exhaust Stage 1	ON	OFF	OFF
Power Exhaust Stage 2	OFF	ON	OFF
Power Exhaust Stage 3	ON	ON	OFF
Power Exhaust Stage 4	ON	OFF	ON
Power Exhaust Stage 5	OFF	ON	ON
Power Exhaust Stage 6	ON	ON	ON

- If building pressure (**Pressures** → **AIR.P** → **BP**) is less than the building pressure set point (**Configuration** → **BP** → **BP.SP**) minus the building pressure low threshold level (**Configuration** → **BP** → **B.CFG** → **B.P.LP**) subtract a stage of power exhaust.

VFD POWER EXHAUST BUILDING PRESSURE CONTROL (**BP.CF** = 3) — A 4 to 20mA analog output from Economizer Control Board 1 (ECB-1, AO1) is provided as a speed reference for a field-installed VFD power exhaust

accessory. If building pressure (**Pressures** → **AIR.P** → **BP**) rises above the building pressure set point (**BP.SP**) and the supply fan is on, then building pressure control is initialized. Thereafter, if the supply fan relay goes off or if the building pressure drops below the **BP.SP** minus the building pressure set point offset (**BP.SO**) for 5 continuous minutes, building pressure control will be stopped. The 5-minute timer will continue to re-initialize if the VFD is still commanded to a speed > 0%. If the building pressure falls below the set point, the VFD will slow



down automatically. Control is performed with a PID loop where:

$$\text{Error} = \text{BP} - \text{B.P.S.P}$$

$K = 1000 * \text{B.P.R.T}/60$  (normalize the PID control for run rate)

$$P = K * \text{B.P.P} * (\text{error})$$

$I = K * \text{B.P.I} * (\text{error}) + "I"$  calculated last time through the PID

$D = K * \text{B.P.D} * (\text{error} - \text{error computed last time through the PID})$

VFD speed reference (clamped between **BP.MN** and **BP.MX%**) = P + I + D

**Smoke Control Modes** — There are four smoke control modes that can be used to control smoke within areas serviced by the unit: Pressurization mode, Evacuation mode, Smoke Purge mode, and Fire Shutdown. Evacuation, Pressurization and Smoke Purge modes require the Controls Expansion Board (CEM). The Fire Shutdown input is located on the main board (MBB) on terminals TB5-10 and 11. The unit may also be equipped with a factory-installed return air smoke detector that is wired to TB5-10 and 11 and will shut the unit down if a smoke condition is determined. Field-monitoring wiring can be connected to terminal TB5-8 and 9 to monitor the smoke detector. Inputs on the CEM board can be used to put the unit in the Pressurization, Evacuation, and Smoke Purge modes. These switches or inputs are connected to TB6 as shown below. Refer to Major System Components section on page 102 for wiring diagrams.

Pressurization — TB5-12 and 13

Evacuation — TB5-12 and 14

Smoke Purge — TB5-12 and 15

Each mode must be energized individually on discrete inputs and the corresponding alarm is initiated when a mode is activated. The fire system provides a normally closed dry contact closure. Multiple smoke control inputs, sensed by the control will force the unit into a Fire Shutdown mode.

**FIRE-SMOKE INPUTS** — These discrete inputs can be found on the local display under **Inputs** → **FIRE**.

ITEM	EXPANSION	RANGE	CCN POINT	WRITE STATUS
<b>FIRE</b>	FIRE-SMOKE INPUTS			
<b>FSD</b>	Fire Shutdown Input	ALRM/NORM	FSD	forcible
<b>PRES</b>	Pressurization Input	ALRM/NORM	PRES	forcible
<b>EVAC</b>	Evacuation Input	ALRM/NORM	EVAC	forcible
<b>PURG</b>	Smoke Purge Input	ALRM/NORM	PURG	forcible

**Fire Shutdown Mode** — This mode will cause an immediate and complete shutdown of the unit.

**Pressurization Mode** — This mode attempts to raise the pressure of a space to prevent smoke infiltration from an adjacent space. Opening the economizer (thereby closing the return air damper), shutting down power exhaust and turning the indoor fan on will increase pressure in the space.

**Evacuation Mode** — This mode attempts to lower the pressure of the space to prevent infiltrating an adjacent space with its smoke. Closing the economizer (thereby opening the return-air damper), turning on the power exhaust and shutting down the indoor fan decrease pressure in the space.

**Smoke Purge Mode** — This mode attempts to draw out smoke from the space after the emergency condition. Opening the economizer (thereby closing the return-air damper), turning on both the power exhaust and indoor fan will evacuate smoke and bring in fresh air.

**AIRFLOW CONTROL DURING THE FIRE-SMOKE MODES** — All non-smoke related control outputs will get shut down in the fire-smoke modes. Those related to airflow will be controlled as explained below. The following matrix

specifies all actions the control shall undertake when each mode occurs (outputs are forced internally with CCN priority number 1 - "Fire"):

DEVICE	PRESSURIZATION	PURGE	EVACUATION	FIRE SHUTDOWN
<b>Economizer</b>	100%	100%	0%	0%
<b>Indoor Fan — VFD</b>	ON/FSO*	ON/FSO*	OFF	OFF
<b>Power Exhaust</b>	OFF	ON/FSO*	ON/FSO*	OFF
<b>Heat Interlock Relay</b>	ON	ON	OFF	OFF

\*"FSO" refers to the supply VFD fire speed override configurable speed.

#### RELEVANT ITEMS

The economizer's commanded output can be found in **Outputs** → **ECON** → **ECN.C**.

The configurable fire speed override for supply fan VFD is in **Configuration** → **SP** → **SP.FS**.

The supply fan relay's commanded output can be found in **Outputs** → **FANS** → **S.FAN**.

The supply fan VFD's commanded speed can be found in **Outputs** → **FANS** → **S.VFD**.

**Indoor Air Quality Control** — The indoor air quality (IAQ) function will admit fresh air into the space whenever space air quality sensors detect high levels of CO<sub>2</sub>.

When a space or return air CO<sub>2</sub> sensor is connected to the unit control, the unit's IAQ routine allows a demand-based control for ventilation air quantity, by providing a modulating outside air damper position that is proportional to CO<sub>2</sub> level. The ventilation damper position is varied between a minimum ventilation level (based on internal sources of contaminants and CO<sub>2</sub> levels other than from the effect of people) and the maximum design ventilation level (determined at maximum populated status in the building). Demand controlled ventilation (DCV) is also available when the *ComfortLink* unit is connected to a CCN system using *ComfortID*<sup>TM</sup> terminal controls.

This function also provides alternative control methods for controlling the amount of ventilation air being admitted, including fixed outdoor air ventilation rates (measured as cfm), external discrete sensor switch input and externally generated proportional signal controls.

The IAQ function requires the installation of the factory-option economizer system. The DCV sequences also require the connection of accessory (or field-supplied) space or return air CO<sub>2</sub> sensors. Fixed cfm rate control requires the factory-installed outdoor air cfm option. External control of the ventilation position requires supplemental devices, including a 4 to 20 mA signal, a 10 kilo-ohm potentiometer, or a discrete switch input, depending on the method selected. Outside air CO<sub>2</sub> levels may also be monitored directly and high CO<sub>2</sub> economizer restriction applied when an outdoor air CO<sub>2</sub> sensor is connected. (The outdoor CO<sub>2</sub> sensor connection requires installation of the CEM.)

The *ComfortLink* control system has the capability of DCV using an IAQ sensor. The indoor air quality (IAQ) is measured using a CO<sub>2</sub> sensor whose measurements are displayed in parts per million (ppm). The IAQ sensor can be field-installed in the return duct. There is also an accessory space IAQ sensor that can be installed directly in the occupied space. The sensor must provide a 4 to 20 mA output signal and must include its own 24-v supply. The sensor connects to terminal TB5-6 and 7. Be sure to leave the 182-ohm resistor in place on terminals 6 and 7.

**OPERATION** — The unit's indoor air quality algorithm modulates the position of the economizer damper between two user configurations depending upon the relationship between the IAQ and the outdoor air quality (OAQ). Both of these values can be read at the **Inputs** → **AIR.Q** submenu. The lower of these two configurable positions is referred to as the IAQ Demand

Vent Min Position (*IAQ.M*), while the higher is referred to as Economizer Minimum Position (*EC.MN*). The *IAQ.M* should be set to an economizer position that brings in enough fresh air to remove contaminants and CO<sub>2</sub> generated by sources other than people. The *EC.MN* value should be set to an economizer position that brings in enough fresh air to remove contaminants and CO<sub>2</sub> generated by all sources including people. The *EC.MN* value is the design value for maximum occupancy.

The logic that is used to control the dampers in response to IAQ conditions is shown in Fig. 12. The *ComfortLink* controls will begin to open the damper from the *IAQ.M* position when the IAQ level begins to exceed the OAQ level by a configurable amount, which is referred to as Differential Air Quality Low Limit (*DAQ.L*).

If OAQ is not being measured, OAQ can be manually configured. It should be set at around 400 to 450 ppm or measured with a handheld sensor during the commissioning of the unit. The OAQ reference level can be set using the OAQ Reference Set Point (*OAQ.U*). When the differential between IAQ and OAQ reaches the configurable Diff. Air Quality Hi Limit (*DAQ.H*), then the economizer position will be *EC.MN*.

When the IAQ-OAQ differential is between *DAQ.L* and *DAQ.H*, the control will modulate the damper between *IAQ.M* and *EC.MN* as shown in Fig. 12. The relationship is a linear relationship but other non-linear options can be used. The damper position will never exceed the bounds specified by *IAQ.M* and *EC.MN* during IAQ control.

If the building is occupied and the indoor fan is running and the differential between IAQ and OAQ is less than *DAQ.L*, the economizer will remain at *IAQ.M*. The economizer will not close completely. The damper position will be 0 when the fan is not running or the building is unoccupied. The damper position may exceed *EC.MN* in order to provide free cooling.

The *ComfortLink* controller is configured for air quality sensors which provide 4 mA at 0 ppm and 20 mA at 2000 ppm. If a sensor has a different range, these bounds must be reconfigured. These pertinent configurations for ranging the air quality sensors are *IQ.R.L*, *IQ.R.H*, *OQ.R.L* and *OQ.R.H*. The bounds represent the PPM corresponding to 4 mA (low) and 20 mA (high) for IAQ and OAQ, respectively.

If OAQ exceeds the OAQ Lockout Value (*OAQ.L*), then the economizer will remain at *IAQ.M*. This is used to limit the use of outside air which outdoor air CO<sub>2</sub> levels are above the *OAQ.L* limit. Normally a linear control of the damper vs. the IAQ control signal can be used, but the control also supports non-linear control. Different curves can be used based on the Diff.AQ Responsiveness Variable (*IAQ.R*). See Fig. 13.

SETTING UP THE SYSTEM — The IAQ configuration options are under the Local Display Mode *Configuration* → *IAQ*. See Table 84.

Economizer Min Position (*Configuration* → *IAQ* → *DCV.C* → *EC.MN*) — This is the fully occupied minimum economizer position.

IAQ Demand Vent Min Pos. (*Configuration* → *IAQ* → *DCV.C* → *IAQ.M*) — This configuration will be used to set the minimum damper position in the occupied period when there is no IAQ demand.

IAQ Analog Sensor Config (*Configuration* → *IAQ* → *AQ.CF* → *IQ.A.C*) — This is used to configure the type of IAQ position control. It has the following options:

- *IQ.A.C* = 0 (No analog input). If there is no other minimum position control, the economizer minimum position will be *Configuration* → *IAQ* → *DCV.C* → *EC.MN* and there will be no IAQ control.
- *IQ.A.C* = 1 (IAQ analog input). An indoor air (space or return air) CO<sub>2</sub> sensor is installed. If an outdoor air CO<sub>2</sub> sensor is also installed, or OAQ is broadcast on the CCN,

or if a default OAQ value is used, then the unit can perform IAQ control.

- *IQ.A.C* = 2 (IAQ analog input with minimum position override) — If the differential between IAQ and OAQ is above *Configuration* → *IAQ* → *AQ.SP* → *DAQ.H*, the economizer minimum position will be the IAQ override position (*Configuration* → *IAQ* → *AQ.SP* → *IQ.O.P*).
- *IQ.A.C* = 3 (4 to 20 mA minimum position) — With a 4 to 20 mA signal connected to TB5-6 and 7, the economizer minimum position will be scaled linearly from 0% (4 mA) to *EC.MX* (20 mA).

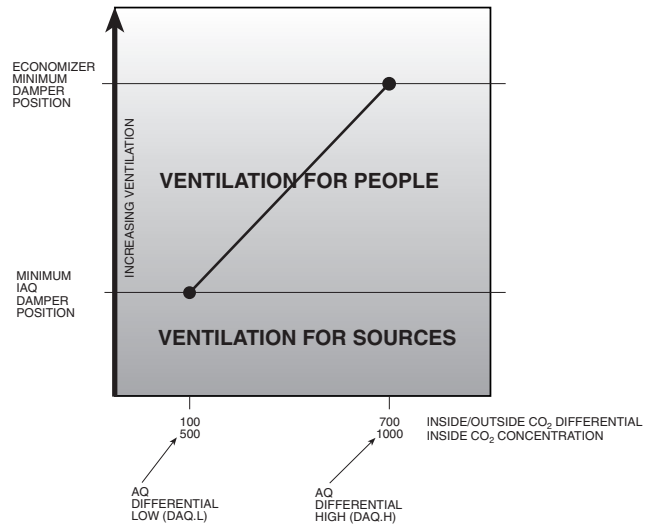
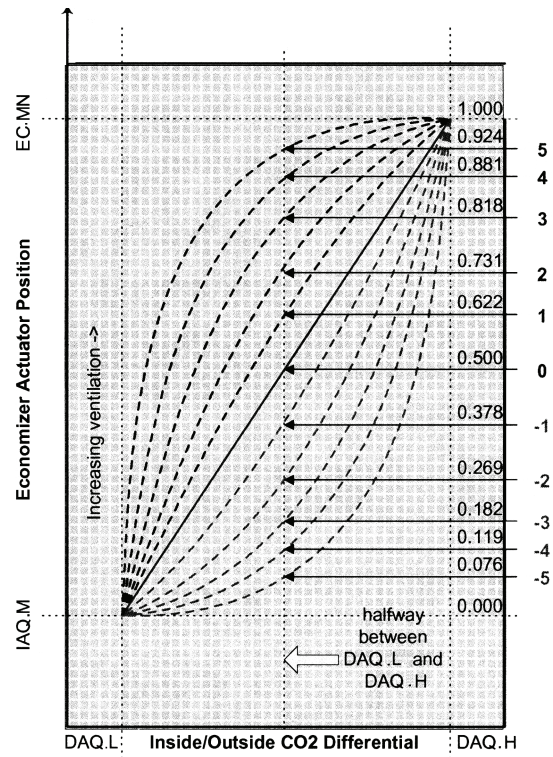


Fig. 12 — IAQ Control



NOTE: Calculating the *IAQ.M* and *EC.MN* damper position based on differential IAQ measurement.

Based on the configuration parameter *IAQREACT*, the reaction to damper positioning based on differential air quality ppm can be adjusted.

- IAQREACT = 1 to 5 (more responsive)
- IAQREACT = 0 (linear)
- IAQREACT = -1 to -5 (less responsive)

Fig. 13 — IAQ Response Curve



- **IQ.A.C** = 4 (10K potentiometer minimum position) — With a 10K linear potentiometer connected to TB5-6 and 7, the economizer minimum position will be scaled linearly from 0% (0 kilo-ohms) to **EC.MX** (10 kilo-ohms).

**IAQ Analog Fan Config (Configuration → IAQ → AQ.CF → IQ.A.F)** — This configuration is used to configure the control of the indoor fan. If this option is used then the IAQ sensor must be in the space and not in the return duct. It has the following configurations:

- **IQ.A.F** = 0 (No Fan Start) — IAQ demand will never override normal indoor fan operation during occupied or unoccupied period and turn it on.
- **IQ.A.F** = 1 (Fan On If Occupied) — IAQ demand will override normal indoor fan operation and turn it on (if off) only during the occupied period (CV operation with automatic fan).
- **IQ.A.F** = 2 (Fan On Occupied/Unoccupied) — IAQ demand will always override normal indoor fan operation and turn it on (if off) during both the occupied and unoccupied period. For **IQ.A.F** = 1 or 2, the fan will be turned on as described above when DAQ is above the DAQ Fan On Set Point (**Configuration → IAQ → AQ.SP → D.F.ON**). The fan will be turned off when DAQ is below the DAQ Fan Off Set Point (**Configuration → IAQ → AQ.SP → D.F.OF**). The control can also be set up to respond to a discrete IAQ input. The discrete input is connected to TB5-6 and 7.

**IAQ Discrete Input Config (Configuration → IAQ → AQ.CF → IQ.I.C)** — This configuration is used to set the type of IAQ sensor. The following are the options:

- **IQ.I.C** = 0 (No Discrete Input) — This is used to indicate that no discrete input will be used and the standard IAQ sensor input will be used.
- **IQ.I.C** = 1 (IAQ Discrete Input) — This will indicate that the IAQ level (high or low) will be indicated by the discrete input. When the IAQ level is low, the economizer minimum position will be **Configuration → IAQ → DCV.C → IAQ.M**.
- **IQ.I.C** = 2 (IAQ Discrete Input with Minimum Position Override) — This will indicate that the IAQ level (high or low) will be indicated by the discrete input and the economizer minimum position will be the IAQ override position, **IQ.O.P** (when high).

It is also necessary to configure how the fan operates when using the IAQ discrete input.

**IAQ Discrete Fan Config (Configuration → IAQ → AQ.CF → IQ.I.F)** — This is used to configure the operation of the fan during an IAQ demand condition. It has the following configurations:

- **IQ.I.F** = 0 (No Fan Start) — IAQ demand will never override normal indoor fan operation during occupied or unoccupied period and turn it on.
- **IQ.I.F** = 1 (Fan On If Occupied) — IAQ demand will override normal indoor fan operation and turn it on (if off) only during the occupied period (CV operation with automatic fan).
- **IQ.I.F** = 2 (Fan On Occupied/Unoccupied) — IAQ demand will always override normal indoor fan operation and turn it on (if off) during both the occupied and unoccupied period.

**OAQ 4-20 mA Sensor Config (Configuration → IAQ → AQ.CF → OQ.A.C)** — This is used to configure the type of outdoor sensor that will be used for OAQ levels. It has the following configuration options:

- **OQ.A.C** = 0 (No Sensor) — No sensor will be used and the internal software reference setting will be used.
- **OQ.A.C** = 1 (OAQ Sensor with DAQ) — An outdoor CO<sub>2</sub> sensor will be used.
- **OQ.A.C** = 2 (4 to 20 mA Sensor without DAQ).

**IAQ Econo Override Pos (Configuration → IAQ → AQ.SP → IQ.O.P)** — This configuration is the position that the economizer goes to when override is in effect.

**Diff. Air Quality Lo Limit (Configuration → IAQ → AQ.SP → DAQ.L)** — This is the differential CO<sub>2</sub> level at which IAQ control of the dampers will be initiated.

**Diff. Air Quality Hi Limit (Configuration → IAQ → AQ.SP → DAQ.H)** — This is the differential CO<sub>2</sub> level at which IAQ control of the dampers will be at maximum and the dampers will be at the **Configuration → IAQ → DCV.C → EC.MN**.

**DAQ ppm Fan Off Set Point (Configuration → IAQ → AQ.SP → D.F.OF)** — This is the CO<sub>2</sub> level at which the indoor fan will be turned off.

**DAQ ppm Fan On Set Point (Configuration → IAQ → AQ.SP → D.F.ON)** — This is the CO<sub>2</sub> level at which the indoor fan will be turned on.

**Diff. IAQ Responsiveness (Configuration → IAQ → AQ.SP → IAQ.R)** — This is the configuration that is used to select the IAQ response curves as shown in Fig. 13.

**OAQ Lockout Value (Configuration → IAQ → AQ.SP → OAQ.L)** — This is the maximum OAQ level above which demand ventilation will be disabled.

**User Determined OAQ (Configuration → IAQ → AQ.SP → OAQ.U)** — If an OAQ sensor is unavailable, the user can manually set the OAQ reading.

**IAQ Low Reference (Configuration → IAQ → AQ.S.R → IQ.R.L)** — This is the reference that will be used with a non-Carrier IAQ sensor that may have a different characteristic curve. It represents the CO<sub>2</sub> level at 4 mA.

**IAQ High Reference (Configuration → IAQ → AQ.S.R → IQ.R.H)** — This is the reference that will be used with a non-Carrier IAQ sensor that may have a different characteristic curve. It represents the CO<sub>2</sub> level at 20 mA.

**OAQ Low Reference (Configuration → IAQ → AQ.S.R → OQ.R.L)** — This is the reference that will be used with a non-Carrier OAQ sensor that may have a different characteristic curve. It represents the CO<sub>2</sub> level at 4 mA.

**OAQ High Reference (Configuration → IAQ → AQ.S.R → OQ.R.H)** — This is the reference that will be used with a non-Carrier OAQ sensor that may have a different characteristic curve. It represents the CO<sub>2</sub> level at 20 mA.

**PRE-OCCUPANCY PURGE** — The control has the option for a pre-occupancy purge to refresh the air in the space prior to occupancy.

This feature is enabled by setting **Configuration → IAQ → IAQ.P → IQ.PG** to Yes.

The IAQ purge will operate under the following conditions:

- **IQ.PG** is enabled
- the unit is in the unoccupied state
- Current Time is valid
- Next Occupied Time is valid
- time is within two hours of the next occupied period
- time is within the purge duration (**Configuration → IAQ → IAQ.P → IQ.P.T**)

If all of the above conditions are met, the following logic is used:

If  $OAT \geq IQ.L.O$  and  $OAT \leq OCS$  and economizer is available then purge will be enabled and the economizer will be commanded to 100%.

If  $OAT < IQ.L.O$  then the economizer will be positioned to the IAQ Purge LO Temp Min Pos (**Configuration → IAQ → IAQ.P → IQ.P.L**)

If neither of the above are true then the dampers will be positioned to the IAQ Purge HI Temp Min Pos (**Configuration → IAQ → IAQ.P → IQ.P.H**)

If this mode is enabled the indoor fan and heat interlock relay (VAV) will be energized.

**IAQ Purge (Configuration → IAQ → IAQ.P → IQ.PG)** — This is used to enable IAQ pre-occupancy purge.

**IAQ Purge Duration (Configuration → IAQ → IAQ.P → IQ.PT)** — This is the maximum amount of time that a purge can occur.

**IAQ Purge Lo Temp Min Pos (Configuration → IAQ → IAQ.P → IQ.PL)** — This is used to configure a low limit for damper position to be used during the purge mode.

**IAQ Purge Hi Temp Min Pos (Configuration → IAQ → IAQ.P → IQ.PH)** — This is used to configure a maximum position for the dampers to be used during the purge cycle.

**IAQ Purge OAT Lockout Temp (Configuration → IAQ → IAQ.P → IQ.L.O)** — Nighttime lockout temperature below which the purge cycle will be disabled.

**Dehumidification and Reheat** — The Dehumidification function will override comfort condition set points based on dry bulb temperature and deliver cooler air to the space in order to satisfy a humidity set point at the space or return air humidity sensor. The Reheat function will energize a suitable heating system concurrent with dehumidification sequence should the dehumidification operation result in excessive cooling of the space condition.

The dehumidification sequence requires the installation of a space or return air humidity sensor or a discrete switch input. An ECB option is required to accommodate an RH (relative humidity) sensor connection. A CEM (option or accessory) is required to accommodate an RH switch. Reheat is possible when multiple-step staged gas control option or hydronic heat field-installed coil is installed. Reheat is also possible using a heat reclaim coil (field-supplied and installed) or a DX (direct expansion) reheat coil.

Dehumidification and reheat control are allowed during Cooling and Vent modes in the Occupied period.

On constant volume units using thermostat inputs (*C.TYP* = 3 or 4), the discrete switch input must be used as the dehumidification control input. The commercial Thermidistat™ device is the recommended accessory device.

**SETTING UP THE SYSTEM** — The settings for dehumidification can be found at the local display at **Configuration → DEHU**. See Table 85.

**Dehumidification Configuration (D.SEL)** — The dehumidification configuration can be set for the following settings:

- **D.SEL** = 0 — No dehumidification and reheat.
- **D.SEL** = 1 — The control will perform dehumidification and reheat with staged gas only.
- **D.SEL** = 2 — The control will perform both dehumidification and reheat with third party heat via an alarm relay. In the case of **D.SEL**=2, during dehumidification, the alarm relay will close to convey the need for reheat. A typical application might be to energize a 3-way valve to perform DX reheat.

**Dehumidification Sensor (D.SEN)** — The sensor can be configured for the following settings:

- **D.SEN** = 1 — Initiated by return air relative humidity sensor.
- **D.SEN** = 2 — Initiated by discrete input.

**Economizer Disable in Dehum Mode (D.EC.D)** — This configuration determines economizer operation during Dehumidification mode.

- **D.EC.D** = YES — Economizer disabled during dehumidification (default).
- **D.EC.D** = NO — Economizer not disabled during dehumidification.

**Table 84 — Indoor Air Quality Configuration**

ITEM	EXPANSION	RANGE	UNITS	CCN POINT	DEFAULT
<b>DCV.C</b>	DCV ECONOMIZER SETPOINTS				
<b>EC.MN</b>	Economizer Min.Position	0 - 100	%	ECONOMIN	5
<b>IAQ.M</b>	IAQ Demand Vent Min.Pos.	0 - 100	%	IAQMINP	0
<b>AQ.CF</b>	AIR QUALITY CONFIGS				
<b>IQ.A.C</b>	IAQ Analog Sensor Config	0 - 4		IAQANCFG	0
<b>IQ.A.F</b>	IAQ 4-20 ma Fan Config	0 - 2		IAQANFAN	0
<b>IQ.I.C</b>	IAQ Discrete Input Config	0 - 2		IAQINCFG	0
<b>IQ.I.F</b>	IAQ Disc.In. Fan Config	0 - 2		IAQINFAN	0
<b>OQ.A.C</b>	OAQ 4-20ma Sensor Config	0 - 2		OAQANCFG	0
<b>AQ.SP</b>	AIR QUALITY SETPOINTS				
<b>IQ.O.P</b>	IAQ Econo Override Pos.	0 - 100	%	IAQOVPOS	100
<b>DAQ.L</b>	Diff.Air Quality LoLimit	0 - 1000		DAQ_LOW	100
<b>DAQ.H</b>	Diff. Air Quality HiLimit	100 - 2000		DAQ_HIGH	700
<b>D.F.OF</b>	DAQ PPM Fan Off Setpoint	0 - 2000		DAQFNOFF	200
<b>D.F.ON</b>	DAQ PPM Fan On Setpoint	0 - 2000		DAQFNON	400
<b>IAQ.R</b>	Diff. AQ Responsiveness	-5 - 5		IAQREACT	0
<b>OAQ.L</b>	OAQ Lockout Value	0 - 2000		OAQLOCK	0
<b>OAQ.U</b>	User Determined OAQ	0 - 5000		OAQ_USER	400
<b>AQ.S.R</b>	AIR QUALITY SENSOR RANGE				
<b>IQ.R.L</b>	IAQ Low Reference	0 - 5000		IAQREFL	0
<b>IQ.R.H</b>	IAQ High Reference	0 - 5000		IAQREFH	2000
<b>OQ.R.L</b>	OAQ Low Reference	0 - 5000		OAQREFL	0
<b>OQ.R.H</b>	OAQ High Reference	0 - 5000		OAQREFH	2000
<b>IAQ.P</b>	IAQ PRE-OCCUPIED PURGE				
<b>IQ.PG</b>	IAQ Purge	Yes/No		IAQPURGE	No
<b>IQ.PT</b>	IAQ Purge Duration	5 - 60	min	IAQPTIME	15
<b>IQ.PL</b>	IAQ Purge LoTemp Min Pos	0 - 100	%	IAQPLTMP	10
<b>IQ.PH</b>	IAQ Purge HiTemp Min Pos	0 - 100	%	IAQPHTMP	35
<b>IQ.L.O</b>	IAQ Purge OAT Lockout	35 - 70	dF	IAQPNTLO	50

**Table 85 — Dehumidification Configuration**

ITEM	EXPANSION	RANGE	UNITS	CCN POINT	DEFAULT
<b>DEHU</b>	DEHUMIDIFICATION CONFIG.				
<b>D.SEL</b>	Dehumidification Config	0-2		DHSELECT	0
<b>D.SEN</b>	Dehumidification Sensor	1-2		DHSENSOR	1
<b>D.EC.D</b>	Econ disable in DH mode?	Yes/No		DHECDISA	Yes
<b>D.V.CF</b>	Vent Reheat Setpt Select	0-1		DHVHTCFG	0
<b>D.V.RA</b>	Vent Reheat RAT offset	0-8	^F	DHVRAOFF	0
<b>D.V.HT</b>	Vent Reheat Setpoint	55-95	dF	DHVHT_SP	70
<b>D.C.SP</b>	Dehumidify Cool Setpoint	40-55	dF	DHCOOLSP	45
<b>D.RH.S</b>	Dehumidify RH Setpoint	10-90	%	DHRELHSP	55

**Vent Reheat Set Point Select (D.V.CF)** — This configuration determines how the vent reheat set point is selected.

- **D.V.CF** = 0 — Reheat follows an offset subtracted from return air temperature (**D.V.RA**).
- **D.V.CF** = 1 — Reheat follows a dehumidification heat set point (**D.V.HT**).

**Vent Reheat RAT Offset (D.V.RA)** — Set point offset used only during the vent mode. The air will be reheated to return-air temperature less this offset.

**Vent Reheat Set Point (D.V.HT)** — Set point used only during the vent mode. The air will be reheated to this set point.

**Dehumidify Cool Set Point (D.C.SP)** — This is the dehumidification cooling set point.

**Dehumidity RH Set Point (D.RH.S)** — This is the dehumidification relative humidity trip point.

**OPERATION** — Dehumidification and reheat can only occur if the unit is equipped with either staged gas or hydronic heat. Dehumidification without reheat can be done on any unit but **Configuration** → **DEHU** → **D.SEL** must be set to 2.

If the machine’s control type is a TSTAT type (**Configuration** → **UNIT** → **C.TYP**=3 or 4) and the discrete input selection for the sensor is not configured (**D.SEN** not equal to 2), dehumidification will be disabled.

If the machine’s control type is a TSTAT type (**Configuration** → **UNIT** → **C.TYP**=3 or 4) and the economizer is able to provide cooling, a dehumidification mode may be called out, but the control will not request mechanical cooling.

If a 2-stage control type is selected (**Configuration** → **UNIT** → **C.TYP** = 4 or 6), then the economizer, if active, locks out mechanical cooling during the Dehumidification mode.

**NOTE:** Configuring **Configuration** → **DEHU** → **D.SEN** to 2 will enable the CEM board along with the sensor selected for control.

**NOTE:** If **Configuration** → **DEHU** → **D.SEL** = 1 or 2, then staged gas control will be automatically enabled (**Configuration** → **HEAT** → **HT.CF** will be set to 3).

If a tempering, unoccupied or “mechanical cooling locked out” HVAC mode is present, dehumidification will be disabled. An HVAC Off, Vent or Cool mode must be in effect to launch either a Reheat or Dehumidification mode.

If an associated sensor responsible for dehumidification fails, dehumidification will not be attempted (**SPRH, RARH**).

**Initiating a Reheat or Dehumidification Mode** — To call out a Reheat mode in the Vent or the Off HVAC mode, or to call out a Dehumidification mode in a Cool HVAC mode, one of the following conditions must be true:

- The space is occupied and the humidity is greater than the relative humidity trip point (**D.RH.S**).
- The space is occupied and the discrete humidity input is closed.

**Dehumidification and Reheat Control** — If a dehumidification mode is initiated, the rooftop will attempt to lower humidity as follows:

- **Economizer Cooling** — The economizer, if allowed to perform free cooling, will have its control point (**Run Status** → **VIEW** → **EC.C.P**) set to **Configuration** → **DEHU**

→ **D.C.SP**. If **Configuration** → **DEHU** → **D.EC.D** is disabled, the economizer will always be disabled during dehumidification.

- **Cooling** — For all cooling control types: A High Cool HVAC mode will be requested internally to the control to maintain diagnostics, although the end user will see a Dehumidification mode at the display. In addition, for multi-stage cooling units the cooling control point will be set to **Configuration** → **DEHU** → **D.C.SP** (no SASP reset is applied).
- **Reheat When Cooling Demand is Present** — For reheat control during dehumidification: If reheat follows an offset subtracted from return-air temperature (**Configuration** → **DEHU** → **D.SEL** = 2), then no heating will be initiated and the alarm relay will be energized. If **Configuration** → **DEHU** → **D.SEL** = 1 and **Configuration** → **HEAT** → **HT.CF** = staged gas or hot water valve, then the selected heating control type will operate in the low heat/modulating mode.
- The heating control point will be whatever the actual cooling set point would have been (without any supply air reset applied).
- **Reheat During Vent Mode** — If configured (**Configuration** → **DEHU** → **D.V.CF** = 0), the heating control point will be equal to RAT – **D.V.RA**. If configured (**Configuration** → **DEHU** → **D.V.CF**=1), the heating control point will be equal to the **D.V.HT** set point.

**Ending Dehumidification and Reheat Control** — When either the humidity sensor fall 5% below the set point (**Configuration** → **DEHU** → **D.RH.S**) or the discrete input reads “LOW”, the Dehumidification mode will end.

**Temperature Compensated Start** — This logic is used when the unit is in the unoccupied state. The control will calculate early Start Bias time based on Space Temperature deviation from the occupied cooling and heating set points. This will allow the control to start the unit so that the space is at conditioned levels when the occupied period starts. This is required for ASHRAE 90.1 compliance. A space sensor is required for non-linkage applications.

**SETTING UP THE SYSTEM** — The settings for temperature compensated start can be found in the local display under **Configuration** → **UNIT**.

ITEM	EXPANSION	RANGE	UNITS	CCN POINT
<b>TCS.C</b>	Temp.Cmp.Strt.Cool Factr	0 - 60	min	TCSTCOOL
<b>TCS.H</b>	Temp.Cmp.Strt.Heat Factr	0 - 60	min	TCSTHEAT

**TCST-Cool Factor (TCS.C)** — This is the factor for the start time bias equation for cooling.

**TCST-Heat Factor (TCS.H)** — This is the factor for the start time bias equation for heating.

**NOTE:** Temperature compensated start is disabled when these factors are set to 0.

**TEMPERATURE COMPENSATED START LOGIC** — The following conditions must be met:

- Unit is in unoccupied state.
- Next occupied time is valid.
- Current time of day is valid.

- Valid space temperature reading is available (sensor or DAV-Linkage).

The algorithm will calculate a Start Bias time in minutes using the following equations:

If (space temperature > occupied cooling set point)

$$\text{Start Bias Time} = (\text{space temperature} - \text{occupied cooling set point}) * TCS.C$$

If (space temperature < occupied heating set point)

$$\text{Start Bias Time} = (\text{occupied heating set point} - \text{space temperature}) * TCS.H$$

When the Start Bias Time is greater than zero the algorithm will subtract it from the next occupied time to calculate the new start time. When the new start time is reached, the Temperature Compensated Start mode is set (*Operating Modes* → *MODE* → *T.C.ST*), the fan is started and the unit controlled as in an occupied state. Once set, Temperature Compensated mode will stay on until the unit goes into the Occupied mode. The Start Bias Time will be written into the CCN Linkage Equipment Table if the unit is controlled in DAV mode. If the Unoccupied Economizer Free Cool mode is active (*Operating Modes* → *HVAC* = “UNOCC FREE COOL”) when temperature compensated start begins, the Unoccupied Free Cool mode will be stopped.

**Carrier Comfort Network® (CCN) System** — It is possible to configure the *ComfortLink* control to participate as an element of the Carrier Comfort Network (CCN) system directly from the local display. This section will deal with explaining the various programmable options which are found under the *CCN* sub-menu in the *Configuration* mode.

The major configurations for CCN programming are located in the local displays at *Configuration* → *CCN*. See Table 86.

**CCN Address (CCNA)** — This configuration is the CCN address the rooftop is assigned.

**CCN Bus Number (CCNB)** — This configuration is the CCN bus the rooftop is assigned.

**CCN Baud Rate (BAUD)** — This configuration is the CCN baud rate. For units equipped with the optional UPC, the CCN Baud Rate must be set to 9600.

**CCN Time/Date Broadcast (TM.DT)** — If this configuration is set to ON, the control will periodically send the time and date out onto the CCN bus once a minute. If this device is on a CCN network then it will be important to make sure that only one device on the bus has this configuration set to ON. If more than one time broadcaster is present, problems with the time will occur.

NOTE: Only the time and date broadcaster can perform daylight savings time adjustments. Even if the rooftop is stand alone, the user may want to set this to ON to accomplish the daylight/savings function.

**CCN OAT Broadcast (OAT.B)** — If this configuration is set to ON, the control will periodically broadcast its outside-air temperature at a rate of once every 30 minutes.

**CCN OARH Broadcast (ORH.B)** — If this configuration is set to ON, the control will periodically broadcast its outside air relative humidity at a rate of once every 30 minutes.

**CCN OAQ Broadcast (OAQ.B)** — If this configuration is set to ON, the control will periodically broadcast its outside air quality reading at a rate of once every 30 minutes.

**Global Schedule Broadcast (G.S.B)** — If this configuration is set to ON and the schedule number (*SCH.N*) is between 65 and 99, then the control will broadcast the internal time schedule once every 2 minutes.

**CCN Broadcast Acknowledger (B.ACK)** — If this configuration is set to ON, then when any broadcasting is done on the bus, this device will respond to and acknowledge. Only one device per bus can be configured for this option.

**Schedule Number (SCH.N)** — This configuration determines what schedule the control may follow.

*SCH.N* = 0 The control is always occupied.

*SCH.N* = 1 The control follows its internal time schedules. The user may enter any number between 1 and 64 but it will be overwritten to “1” by the control as it only has one internal schedule.

*SCH.N* = 65-99 The control is either set up to receive to a broadcasted time schedule set to this number or the control is set up to broadcast its internal time schedule (*G.S.B*) to the network and this is the global schedule number it is broadcasting. If this is the case, then the control still follows its internal time schedules.

**Accept Global Holidays? (HOL.T)** — If a device is broadcasting the time on the bus, it is possible to accept the time yet not accept the global holiday from the broadcast message.

**Override Time Limit (O.T.L)** — This configuration allows the user to decide how long an override occurs when it is initiated. The override may be configured from 1 to 4 hours. If the time is set to 0, the override function will become disabled.

**Table 86 — CCN Configuration**

ITEM	EXPANSION	RANGE	UNITS	POINT	DEFAULT
<b>CCN</b>	CCN CONFIGURATION				
<b>CCNA</b>	CCN Address	1 - 239		CCNADD	1
<b>CCNB</b>	CCN Bus Number	0 - 239		CCNBUS	0
<b>BAUD</b>	CCN Baud Rate	1 - 5		CCNBAUDD	3*
<b>BROD</b>	CCN BROADCAST DEFINITIONS				
<b>TM.DT</b>	CCN Time/Date Broadcast	ON/OFF		CCNBC	On
<b>OAT.B</b>	CCN OAT Broadcast	ON/OFF		OATBC	Off
<b>ORH.B</b>	CCN OARH Broadcast	ON/OFF		OARHBC	Off
<b>OAQ.B</b>	CCN OAQ Broadcast	ON/OFF		OAQBC	Off
<b>G.S.B</b>	Global Schedule Broadcast	ON/OFF		GSBC	Off
<b>B.ACK</b>	CCN Broadcast Ack'er	ON/OFF		CCNBCACK	Off
<b>SC.OV</b>	CCN SCHEDULES-OVERRIDES				
<b>SCH.N</b>	Schedule Number	0 - 99		SCHEDNUM	1
<b>HOL.T</b>	Accept Global Holidays?	YES/NO		HOLIDAYT	No
<b>O.T.L.</b>	Override Time Limit	0 - 4	HRS	OTL	1
<b>OV.EX</b>	Timed Override Hours	0 - 4	HRS	OVR_EXT	0
<b>SPT.O</b>	SPT Override Enabled ?	YES/NO		SPT_OVER	Yes
<b>T58.O</b>	T58 Override Enabled ?	YES/NO		T58_OVER	Yes
<b>GL.OV</b>	Global Sched. Override ?	YES/NO		GLBLOVER	No

\* For units equipped with optional UPC, the CCN Baud Rate must be set to 3.

Timed Override Hours (OVEX) — This displays the current number of hours left in an override. It is possible to cancel an override in progress by writing “0” to this variable, thereby removing the override time left.

SPT Override Enabled? (SPT.O) — If a space sensor is present, then it is possible to override an unoccupied period by pushing the override button on the T55 or T56 sensor. This option allows the user to disable this function by setting this configuration to NO.

T58 Override Enabled? (T58.O) — The T58 sensor is a CCN device that allows cooling/heating set points to be adjusted, space temperature to be written to the rooftop unit, and the ability to initiate a timed override. This option allows the user to disable the override initiated from the T58 sensor by setting this option to NO.

Global Schedule Override? (GL.OV) — If the control is set to receive global schedules then it is also possible for the global schedule broadcaster to call out an override condition as well. This configuration allows the user to disable the global schedule broadcaster from overriding the control.

**Alert Limit Configuration** — The ALLM submenu is used to configure the alert limit set points. A list is shown in Table 87.

SPT Low Alert Limit/Occ (SPL.O) — If the space temperature is below the configurable occupied SPT Low Alert Limit (SPL.O), then Alert 300 will be generated and the unit will be stopped. The alert will automatically reset.

SPT High Alert Limit/Occ (SPH.O) — If the space temperature is above the configurable occupied SPT High Alert Limit (SPH.O), then Alert 301 will be generated and the unit will be stopped. The alert will automatically reset.

SPT Low Alert Limit/Unocc (SPL.U) — If the space temperature is below the configurable unoccupied SPT Low Alert Limit (SPL.U), then Alert 300 will be generated and the unit will be stopped. The alert will automatically reset.

SPT High Alert Limit/Unocc (SPH.U) — If the space temperature is above the configurable unoccupied SPT High Alert Limit (SPH.U), then Alert 301 will be generated and the unit will be stopped. The alert will automatically reset.

EDT Low Alert Limit/Occ (SAL.O) — If the evaporator discharge temperature is below the configurable occupied evaporator discharge temperature (EDT) Low Alert Limit (SAL.O), then Alert 302 will be generated and cooling operation will be stopped but heating operation will continue. The alert will automatically reset.

EDT High Alert Limit/Occ (SAH.O) — If the evaporator discharge temperature is above the configurable occupied EDT High Alert Limit (SAH.O), then Alert 303 will be generated and heating operation will be stopped but cooling operation will continue. The alert will automatically reset.

EDT Low Alert Limit/Unocc (SAL.U) — If the evaporator discharge temperature is below the configurable unoccupied EDT Low Alert Limit (SAL.U), then Alert 302 will be generated and cooling operation will be stopped but heating operation will continue. The alert will automatically reset.

EDT High Alert Limit/Unocc (SAH.U) — If the evaporator discharge temperature is above the configurable unoccupied EDT High Alert Limit (SAH.U), then Alert 303 will be generated and heating operation will be stopped but cooling operation will continue. The alert will automatically reset.

RAT Low Alert Limit/Occ (RAL.O) — If the return-air temperature is below the configurable occupied RAT Low Alert Limit (RAL.O), then Alert 304 will be generated and internal routines will be modified. Unit operation will continue but VAV heating operation will be disabled. The alert will automatically reset.

RAT High Alert Limit/Occ (RAH.O) — If the return-air temperature is above the configurable occupied RAT High Alert Limit (RAH.O), then Alert 305 will be generated and operation will continue. The alert will automatically reset.

RAT Low Alert Limit/Unocc (RAL.U) — If the return-air temperature is below the configurable unoccupied RAT Low Alert Limit (RAL.U), then Alert 304 will be generated. Unit operation will continue but VAV heating operation will be disabled. The alert will automatically reset.

RAT High Alert Limit/Unocc (RAH.U) — If the return-air temperature is above the configurable unoccupied RAT High Alert Limit (RAH.U), then Alert 305 will be generated. Operation will continue. The alert will automatically reset.

RARH Low Alert Limit (RRHL) — If the unit is configured to use a return air relative humidity sensor (Configuration → UNIT → SENS → RRHS), and the measured level is below the configurable RH Low Alert Limit (RRHL), then Alert 308 will occur. The unit will continue to run and the alert will automatically reset.

RARH High Alert Limit (RRHH) — If the unit is configured to use a return air relative humidity sensor (Configuration → UNIT → SENS → RRHS), and the measured level is above the configurable RARH High Alert Limit (RRHH), then Alert 309 will occur. The unit will continue to run and the alert will automatically reset.

Supply Duct Pressure Low Alert Limit (SPL) — If the unit is a VAV unit with a supply duct pressure sensor and the measured supply duct static pressure is below the configurable SP Low Alert Limit (DPL), then Alert 310 will occur. The unit will continue to run and the alert will automatically reset.

Supply Duct Pressure High Alert Limit (SPH) — If the unit is a VAV unit with a supply duct pressure sensor and the measured supply duct static pressure is above the configurable SP High Alert Limit (SPH), then Alert 311 will occur. The unit will continue to run and the alert will automatically reset.

Building Pressure Low Alert Limit (BPL) — If the unit is configured to use modulating power exhaust then a building static pressure limit can be configured using the BP Low Alert Limit (BPL). If the measured pressure is below the limit then Alert 312 will occur.

Building Pressure High Alert Limit (BPH) — If the unit is configured to use modulating power exhaust then a building static pressure limit can be configured using the BP Hi Alert Limit (BPH). If the measured pressure is above the limit, then Alert 313 will occur.

Indoor Air Quality High Alert Limit (IAQH) — If the unit is configured to use a CO<sub>2</sub> sensor and the level is above the configurable IAQ High Alert Limit (IAQH) then the alert will occur. The unit will continue to run and the alert will automatically reset.

**Sensor Trim Configuration** — The TRIM submenu is used to calibrate the sensor trim settings. The trim settings are used when the actual measured reading does not match the sensor output. The sensor can be adjusted to match the actual measured reading with the trim function. A list is shown in Table 88.

**IMPORTANT:** Sensor trim must not be used to extend unit operation past the allowable operating range. Doing so may void the warranty.

Air Temperature Leaving Supply Fan Sensor (SAT.T) — This variable is used to adjust the supply fan temperature sensor reading. The sensor reading can be adjusted ± 10° F to match the actual measured temperature.

Return Air Temperature Sensor Trim (RAT.T) — This variable is used to adjust the return air temperature sensor reading.

The sensor reading can be adjusted  $\pm 10^\circ$  F to match the actual measured temperature.

**Outdoor Air Temperature Sensor Trim (OAT.T)** — This variable is used to adjust the outdoor air temperature sensor reading. The sensor reading can be adjusted  $\pm 10^\circ$  F to match the actual measured temperature.

**Space Temperature Sensor Trim (SPT.T)** — This variable is used to adjust the space temperature sensor reading. The sensor reading can be adjusted  $\pm 10^\circ$  F to match the actual measured temperature.

**Circuit A Saturated Condenser Temperature Trim (CTA.T)** — This variable is used to adjust the saturated condenser temperature sensor reading for circuit A. The sensor reading can be adjusted  $\pm 30^\circ$  F to match the actual measured temperature. Used on 48/50AJ,AK,AW,AY units only.

**Circuit B Saturated Condenser Temperature Trim (CTB.T)** — This variable is used to adjust the saturated condenser temperature sensor reading for circuit B. The sensor reading can be adjusted  $\pm 30^\circ$  F to match the actual measured temperature. Used on 48/50AJ,AK,AW,AY units only.

**Suction Pressure Circuit A Trim (SPA.T)** — This variable is used to adjust the suction pressure sensor reading for circuit A. The sensor reading can be adjusted  $\pm 50$  psig to match the actual measured pressure.

**Suction Pressure Circuit B Trim (SPB.T)** — This variable is used to adjust the suction pressure sensor reading for circuit B. The sensor reading can be adjusted  $\pm 50$  psig to match the actual measured pressure.

**Discharge Pressure Circuit A Trim (DPA.T)** — This variable is used to adjust the discharge pressure sensor reading for circuit A. The sensor reading can be adjusted  $\pm 50$  psig to match the actual measured pressure. Used on 48/50A2,A3,A4,A5 units only.

**Discharge Pressure Circuit B Trim (DPB.T)** — This variable is used to adjust the discharge pressure sensor reading for circuit B. The sensor reading can be adjusted  $\pm 50$  psig to

match the actual measured pressure. Used on 48/50A2,A3,A4,A5 units only.

**4 to 20 mA Inputs** — There are a number of 4 to 20 mA inputs which may be calibrated. These inputs are located in **Inputs** → **4-20**. They are:

- **SP.M.T** — static pressure milliamp trim
- **BPM.T** — building pressure milliamp trim
- **OA.M.T** — outside air cfm milliamp trim
- **RA.M.T** — return air cfm milliamp trim
- **SA.M.T** — supply air cfm milliamp trim

**Discrete Switch Logic Configuration** — The **SW.LG** submenu is used to configure the normally open/normally closed settings of switches and inputs. This is used when field-supplied switches or input devices are used instead of Carrier devices. The normally open or normally closed setting may be different on a field-supplied device. These points are used to match the control logic to the field-supplied device.

The defaults for this switch logic section will not normally need changing. However, if a field-installed switch is used that is different from the Carrier switch, these settings may need adjustment.

**IMPORTANT:** Many of the switch inputs to the control can be configured to operate as normally open or normally closed.

Settings for switch logic are found at the local displays under the **Configuration** → **SW.LG** submenu. See Table 89.

**Filter Status Input — Clean (FTS.L)** — The filter status input for clean filters is set for normally open. If a field-supplied filter status switch is used that is normally closed for a clean filter, change this variable to closed.

**IGC Feedback — Off (IGC.L)** — The input for IGC feedback is set for normally open for off. If a field-supplied IGC feedback switch is used that is normally closed for feedback off, change this variable to closed.

**Table 87 — Alert Limit Configuration**

ITEM	EXPANSION	RANGE	UNITS	POINT	DEFAULT
<b>SPL.O</b>	SPT lo alert limit/occ	-10-245	dF	SPLO	60
<b>SPH.O</b>	SPT hi alert limit/occ	-10-245	dF	SPHO	85
<b>SPL.U</b>	SPT lo alert limit/unocc	-10-245	dF	SPLU	45
<b>SPH.U</b>	SPT hi alert limit/unocc	-10-245	dF	SPHU	100
<b>SAL.O</b>	EDT lo alert limit/occ	-40-245	dF	SALO	40
<b>SAH.O</b>	EDT hi alert limit/occ	-40-245	dF	SAHO	100
<b>SAL.U</b>	EDT lo alert limit/unocc	-40-245	dF	SALU	40
<b>SAH.U</b>	EDT hi alert limit/unocc	-40-245	dF	SAHU	100
<b>RAL.O</b>	RAT lo alert limit/occ	-40-245	dF	RALO	60
<b>RAH.O</b>	RAT hi alert limit/occ	-40-245	dF	RAHO	90
<b>RAL.U</b>	RAT lo alert limit/unocc	-40-245	dF	RALU	40
<b>RAH.U</b>	RAT hi alert limit/unocc	-40-245	dF	RAHU	100
<b>R.RH.L</b>	RARH low alert limit	0-100	%	RRHL	0
<b>R.RH.H</b>	RARH high alert limit	0-100	%	RRHH	100
<b>SPL</b>	SP low alert limit	0-5	"H2O	SPL	0
<b>SPH</b>	SP high alert limit	0-5	"H2O	SPH	2
<b>BPL</b>	BP lo alert limit	-0.25-0.25	"H2O	BPL	-0.25
<b>BPH</b>	BP high alert limit	-0.25-0.25	"H2O	BPH	0.25
<b>IAQ.H</b>	IAQ high alert limit	0-5000		IAQH	1200

**Table 88 — Sensor Trim Configuration**

ITEM	EXPANSION	RANGE	UNITS	POINT	DEFAULT
<b>SAT.T</b>	Air Temp Lvg SF Trim	-10 - 10	^F	SAT_TRIM	0
<b>RAT.T</b>	RAT Trim	-10 - 10	^F	RAT_TRIM	0
<b>OAT.T</b>	OAT Trim	-10 - 10	^F	OAT_TRIM	0
<b>SPT.T</b>	SPT Trim	-10 - 10	^F	SPT_TRIM	0
<b>CTA.T</b>	Cir A Sat. Cond. Temp Trim	-30 - 30	^F	SCTA_TRIM	0
<b>CTB.T</b>	Cir B Sat. Cond. Temp Trim	-30 - 30	^F	SCTB_TRIM	0
<b>SPA.T</b>	Suct.Press.Circ.A Trim	-50 - 50	PSIG	SPA_TRIM	0
<b>SPB.T</b>	Suct.Press.Circ.B Trim	-50 - 50	PSIG	SPB_TRIM	0
<b>DPA.T</b>	Dis.Press.Circ.A Trim	-50 - 50	PSIG	DPA_TRIM	0
<b>DPB.T</b>	Dis.Press.Circ.B Trim	-50 - 50	PSIG	DPB_TRIM	0

**Remote Switch — Off (RMI.L)** — The remote switch is set for normally open when off. If a field-supplied control switch is used that is normally closed for an off signal, change this variable to closed.

**Economizer Switch — No (ECS.L)** — The economizer switch is set for normally open when low. If a field-supplied economizer switch is used that is normally closed when low, change this variable to closed.

**Fan Status Switch — Off (SFS.L)** — The fan status switch input is set for normally open for off. If a field-supplied fan status switch is used that is normally closed, change this variable to closed.

**Demand Limit Switch 1 — Off (DL1.L)** — The demand limit switch no. 1 input is set for normally open for off. If a field-supplied demand limit switch is used that is normally closed, change this variable to closed.

**Demand Limit Switch 2/Dehumidify — Off (DL2.L)** — The demand limit switch no. 2 input is set for normally open for off. If a field-supplied demand limit switch is used that is normally closed, change this variable to closed.

**IAQ Discrete Input — Low (IAQ.L)** — The IAQ discrete input is set for normally open when low. If a field-supplied IAQ discrete input is used that is normally closed, change this variable to closed.

**Fire Shutdown — Off (FSD.L)** — The fire shutdown input is set for normally open when off. If a field-supplied fire shutdown input is used that is normally closed, change this variable to closed.

**Pressurization Switch — Off (PRS.L)** — The pressurization input is set for normally open when off. If a field-supplied pressurization input is used that is normally closed, change this variable to closed.

**Evacuation Switch — Off (EVC.L)** — The evacuation input is set for normally open when off. If a field-supplied evacuation input is used that is normally closed, change this variable to closed.

**Smoke Purge — Off (PRGL)** — The smoke purge input is set for normally open when off. If a field-supplied smoke purge input is used that is normally closed, change this variable to closed.

**Display Configuration** — The *DISP* submenu is used to configure the local display settings. A list is shown in Table 90.

**Test Display LEDs (TEST)** — This is used to test the operation of the *ComfortLink* display.

**Metric Display (METR)** — This variable is used to change the display from English units to Metric units.

**Language Selection (LANG)** — This variable is used to change the language of the *ComfortLink* display. At this time, only English is available.

**Password Enable (PAS.E)** — This variable enables or disables the use of a password. The password is used to restrict use of the control to change configurations.

**Service Password (PASS)** — This variable is the 4-digit numeric password that is required if enabled.

**Remote Control Switch Input** — The remote switch input is located on the ECB-1 board and connected to TB6 terminals 1 and 3. The switch can be used for several remote control functions. See Table 91.

**Remote Input State (Inputs → GEN.I → REMT)** — This is the actual real time state of the remote input.

**Remote Switch Config (Configuration → UNIT → RM.CF)** — This is the configuration that allows the user to assign different types of functionality to the remote discrete input.

- 0 — NO REMOTE SW — The remote switch will not be used.
- 1 — OCC-UNOCC SW — The remote switch input will control the occupancy state. When the remote switch input is ON, the unit will forced into the occupied mode. When the remote switch is OFF, the unit will be forced into the unoccupied mode.
- 2 — STRT/STOP — The remote switch input will start and stop the unit. When the unit is commanded to stop, any timeguards in place on compressors will be honored first. When the remote switch is ON, the unit will be commanded to stop. When the remote switch is OFF the unit will be enabled to operate.
- 3 — OVERRIDE SW — The remote switch can be used to override any internal or external time schedule being used by the control and force the unit into an occupied mode when the remote input state is ON. When the remote switch is ON, the unit will be forced into an occupied state. When the remote switch is OFF, the unit will use its internal or external time schedules.

**Table 89 — Switch Logic Configuration**

ITEM	EXPANSION	RANGE	CCN POINT	DEFAULT
<b>SW.LG</b>	SWITCH LOGIC: NO / NC			
<b>FTS.L</b>	Filter Status Inpt-Clean	Open/Close	FLTSLOGC	Open
<b>IGC.L</b>	IGC Feedback - Off	Open/Close	GASFANLG	Open
<b>RMI.L</b>	RemSw Off-Unoc-Strt-NoOv	Open/Close	RMTINLOG	Open
<b>ECS.L</b>	Economizer Switch - No	Open/Close	ECOSWLOG	Open
<b>SFS.L</b>	Fan Status Sw. - Off	Open/Close	SFSLOGIC	Open
<b>DL1.L</b>	Dmd.Lmt.Sw.1 - Off	Open/Close	DMD_SW1L	Open
<b>DL2.L</b>	Dmd.Lmt.2 Dehumid - Off	Open/Close	DMD_SW2L	Open
<b>IAQ.L</b>	IAQ Disc.Input - Low	Open/Close	IAQINLOG	Open
<b>FSD.L</b>	Fire Shutdown - Off	Open/Close	FSDLOGIC	Open
<b>PRS.L</b>	Pressurization Sw. - Off	Open/Close	PRESLOGC	Open
<b>EVC.L</b>	Evacuation Sw. - Off	Open/Close	EVACLOGC	Open
<b>PRG.L</b>	Smoke Purge Sw. - Off	Open/Close	PURGLOGC	Open

**Table 90 — Display Configuration**

ITEM	EXPANSION	RANGE	UNITS	POINT	DEFAULT
<b>TEST</b>	Test Display LEDs	ON/OFF		TEST	Off
<b>METR</b>	Metric Display	ON/OFF		DISPUNIT	Off
<b>LANG</b>	Language Selection	0-1 (multi-text strings)		LANGUAGE	0
<b>PAS.E</b>	Password Enable	ENABLE/DISABLE		PASS_EBL	Enable
<b>PASS</b>	Service Password	0000-9999		PASSWORD	1111

**Table 91 — Remote Switch Configuration**

ITEM	EXPANSION	RANGE	CCN POINT
<b>REMT</b>	Remote Input State	ON/OFF	RMTIN
<b>RM.CF</b>	Remote Switch Config	0 - 3	RMTINCFG
<b>RM.LL</b>	RemSw Off-Unoc-Strt-NoOv	Open/Close	RMTINLOG

Remote Switch Logic Configuration (**Configuration** → **SW.LG** → **RM.LL**) — The control allows for the configuration of a normally open/closed status of the remote input switch via **RM.LL**. If this variable is configured OPEN, then when the switch is open, the remote input switch perceives the logic state as OFF. Correspondingly, if **RM.LL** is set to CLOSED, the remote input switch will perceive a closed switch as meaning OFF. See Table 92.

**Hot Gas Bypass** — Hot gas bypass is an active part of the A-Series *ComfortLink* capacity staging and minimum evaporator load protection functions. It is controlled through the Minimum Load Valve function.

The hot gas bypass option consists of a solenoid valve with a fixed orifice sized to provide a nominal 3-ton evaporator load bypass. A hot gas refrigerant line routes the bypassed hot gas from Circuit A's discharge line to Circuit A's evaporator distributor. When the unit control calls for hot gas bypass, the hot gas enters the evaporator coil and adds refrigeration load to the compressor circuit to reduce the cooling effect from Circuit A.

The hot gas bypass system is a factory-installed option installed on Circuit A only. This function is enabled at **Configuration** → **COOL** → **MLV**. When this function is enabled, an additional stage of cooling capacity is provided by the unit control staging sequences (see Tables 52, 54, 58, and 60).

**Space Temperature Offset** — Space temperature offset corresponds to a slider on a T56 sensor that allows the occupant to adjust the space temperature by a configured range during an occupied period. This sensor is only applicable to units that are configured as either 2-Stage SPT or Multi-Stage SPT control (**Configuration** → **UNIT** → **C.TYP** = 5 or 6).

ITEM	EXPANSION	RANGE	UNITS	CCN POINT
<b>S.P.O.S</b>	Space Temp Offset Sensor	Enable/Disable		SPTOSENS
<b>S.P.O.R</b>	Space Temp Offset Range	1 - 10		SPTO_RNG
<b>SPTO</b>	Space Temperature Offset	+ - S.P.O.R	^F	SPTO

Space Temperature Offset Sensor (**Configuration** → **UNIT** → **SENS** → **S.P.O.S**) — This configuration disables the reading of the offset slider.

Space Temperature Offset Range (**Configuration** → **UNIT** → **SENS** → **S.P.O.R**) — This configuration establishes the range, in degrees F, that the T56 slider can affect **SPTO** when adjusting the slider from the far left (-**S.P.O.R**) to the far right (+**S.P.O.R**). The default is 5° F.

**Table 92 — Remote Switch Logic Configuration**

REMOTE SWITCH LOGIC CONFIGURATION ( <b>RM.LL</b> )	SWITCH STATUS	REMOTE INPUT STATE ( <b>REMT</b> )	REMOTE SWITCH CONFIGURATION ( <b>RM.CF</b> )			
			0	1	2	3
			No Remote Switch	Occ-Unocc Switch	Start/Stop	Override
OPEN	OPEN	OFF	xxxxx	Unoccupied	Start	No Override
	CLOSED	ON	xxxxx	Occupied	Stop	Override
CLOSED	OPEN	ON	xxxxx	Occupied	Stop	Override
	CLOSED	OFF	xxxxx	Unoccupied	Start	No Override

Space Temperature Offset Value (**Temperatures** → **AIR.T** → **SPTO**) — The Space Temperature Offset Value is the reading of the slider potentiometer in the T56 that is resolved to delta degrees based on **S.P.O.R**.

**TIME CLOCK CONFIGURATION**

This section describes each Time Clock menu item. Not every point will need to be configured for every unit. Refer to the Controls Quick Start section for more information on what set points need to be configured for different applications. The Time Clock menu items are discussed in the same order that they are displayed in the Time Clock table. The Time Clock table is shown in Table 93.

**Hour and Minute (HH.MM)** — The hour and minute of the time clock are displayed in 24-hour, military time. Time can be adjusted manually by the user.

When connected to the CCN, the unit can be configured to transmit time over the network or receive time from a network device. All devices on the CCN should use the same time. Only one device on the CCN should broadcast time or problems will occur.

**Month of Year (MNTH)** — This variable is the current month of the calendar year.

**Day of Month (DOM)** — This variable is the current day (1 to 31) of the month.

**Day of Week (DAY)** — This variable is the current day of the week (Monday = 1 through Sunday = 7).

**Year (YEAR)** — This variable is the current year (for example, 2005).

**Local Time Schedule (SCH.L)** — This submenu is used to program the time schedules. There are 8 periods (**PER.1** through **PER.8**). Each time period can be used to set up a local schedule for the unit.

Monday In Period (**PER.X** → **DAYS** → **MON**) — This variable is used to include or remove Monday from the schedule. Each period is assigned an occupied on and off time. If this variable is set to YES, then Monday will be included in that period's occupied time schedule. If this variable is set to NO, then the period's occupied time schedule will not be used on Monday. This variable can be set for Periods 1 through 8.

Tuesday In Period (**PER.X** → **DAYS** → **TUE**) — This variable is used to include or remove Tuesday from the schedule. Each period is assigned an occupied on and off time. If this variable is set to YES, then Tuesday will be included in that period's occupied time schedule. If this variable is set to NO, then the period's occupied time schedule will not be used on Tuesday. This variable can be set for Periods 1 through 8.

Wednesday In Period (**PER.X** → **DAYS** → **WED**) — This variable is used to include or remove Wednesday from the schedule. Each period is assigned an occupied on and off time. If this variable is set to YES, then Wednesday will be included in that period's occupied time schedule. If this variable is set to NO, then the period's occupied time schedule will not be used on Wednesday. This variable can be set for Periods 1 through 8.



Thursday In Period (PER.X→DAYS→THU) — This variable is used to include or remove Thursday from the schedule. Each period is assigned an occupied on and off time. If this variable is set to YES, then Thursday will be included in that period's occupied time schedule. If this variable is set to NO, then the period's occupied time schedule will not be used on Thursday. This variable can be set for Periods 1 through 8.

Friday In Period (PER.X→DAYS→FRI) — This variable is used to include or remove Friday from the schedule. Each period is assigned an occupied on and off time. If this variable is set to YES, then Friday will be included in that period's occupied time schedule. If this variable is set to NO, then the period's occupied time schedule will not be used on Friday. This variable can be set for Periods 1 through 8.

Saturday In Period (PER.X→DAYS→SAT) — This variable is used to include or remove Saturday from the schedule. Each period is assigned an occupied on and off time. If this variable is set to YES, then Saturday will be included in that period's occupied time schedule. If this variable is set to NO, then the period's occupied time schedule will not be used on Saturday. This variable can be set for Periods 1 through 8.

Sunday In Period (PER.X→DAYS→SUN) — This variable is used to include or remove Sunday from the schedule. Each period is assigned an occupied on and off time. If this variable is set to YES, then Sunday will be included in that period's occupied time schedule. If this variable is set to NO, then the period's occupied time schedule will not be used on Sunday. This variable can be set for Periods 1 through 8.

Holiday In Period (PER.X→DAYS→HOL) — This variable is used to include or remove a Holiday from the schedule. Each period is assigned an occupied on and off time. If this variable is set to YES, then holidays will be included in that period's occupied time schedule. If this variable is set to NO, then the period's occupied time schedule will not be used on holidays. This variable can be set for Periods 1 through 8.

Occupied From (PER.X→OCC) — This variable is used to configure the start time of the Occupied period. All days in the same period set to YES will enter into Occupied mode at this time.

Occupied To (PER.X→UNC) — This variable is used to configure the end time of the Occupied period. All days in the same period set to YES will exit Occupied mode at this time.

**Local Holiday Schedules (HOL.L)** — This submenu is used to program the local holiday schedules. Up to 30 holidays can be configured. When a holiday occurs, the unit will

follow the occupied schedules that have the HOLIDAY IN PERIOD point set to YES.

Holiday Start Month (HD.01 to HD.30→MON) — This is the start month for the holiday. The numbers 1 to 12 correspond to the months of the year (e.g., January = 1).

Holiday Start Day (HD.01 to HD.30→DAY) — This is the start day of the month for the holiday. The day can be set from 1 to 31.

Holiday Duration (HD.01 to HD.30→LEN) — This is the length in days of the holiday. The holiday can last up to 99 days.

**Daylight Savings Time (DAY.S)** — The daylight savings time function is used in applications where daylight savings time occurs. The function will automatically correct the clock on the days configured for daylight savings time.

**DAYLIGHT SAVINGS START (DS.ST)** — This submenu configures the start date and time for daylight savings.

Daylight Savings Start Month (DS.ST→ST.MN) — This is the start month for daylight savings time. The numbers 1 to 12 correspond to the months of the year (e.g., January = 1).

Daylight Savings Start Week (DS.ST→ST.WK) — This is the start week of the month for daylight savings. The week can be set from 1 to 5.

Daylight Savings Start Day (DS.ST→ST.DY) — This is the start day of the week for daylight savings. The day can be set from 1 to 7 (Sunday=1, Monday=2, etc.).

Daylight Savings Minutes To Add (DS.ST→MIN.A) — This is the amount of time that will be added to the time clock for daylight savings.

**DAYLIGHT SAVINGS STOP (DS.SP)** — This submenu configures the end date and time for daylight savings.

Daylight Savings Stop Month (DS.SP→SP.MN) — This is the stop month for daylight savings time. The numbers 1 to 12 correspond to the months of the year (e.g., January = 1).

Daylight Savings Stop Week (DS.SP→SP.WK) — This is the stop week of the month for daylight savings. The week can be set from 1 to 5.

Daylight Savings Stop Day (DS.SP→SP.DY) — This is the stop day of the week for daylight savings. The day can be set from 1 to 7 (Sunday=1, Monday=2, etc.).

Daylight Savings Minutes To Subtract (DS.SP→MIN.S) — This is the amount of time that will be removed from the time clock after daylight savings ends.

**Table 93 — Time Clock Configuration**

ITEM	EXPANSION	RANGE	POINT	DEFAULT
<b>TIME</b>	<b>TIME OF DAY</b>			
<b>HH.MM</b>	Hour and Minute	00:00	TIME	
<b>DATE</b>	<b>MONTH,DATE,DAY AND YEAR</b>			
<b>MNTH</b>	Month of Year	multi-text strings	MOY	
<b>DOM</b>	Day of Month	0-31	DOM	
<b>DAY</b>	Day of Week	multi-text strings	DOWDISP	
<b>YEAR</b>	Year	e.g. 2003	YOCDISP	
<b>SCH.L</b>	<b>LOCAL TIME SCHEDULE</b>			
<b>PER.1</b>	PERIOD 1			
<b>PER.1→DAYS</b>	DAY FLAGS FOR PERIOD 1			Period 1 only
<b>PER.1→DAYS→MON</b>	Monday in Period	YES/NO	PER1MON	Yes
<b>PER.1→DAYS→TUE</b>	Tuesday in Period	YES/NO	PER1TUE	Yes
<b>PER.1→DAYS→WED</b>	Wednesday in Period	YES/NO	PER1WED	Yes
<b>PER.1→DAYS→THU</b>	Thursday in Period	YES/NO	PER1THU	Yes
<b>PER.1→DAYS→FRI</b>	Friday in Period	YES/NO	PER1FRI	Yes
<b>PER.1→DAYS→SAT</b>	Saturday in Period	YES/NO	PER1SAT	Yes
<b>PER.1→DAYS→SUN</b>	Sunday in Period	YES/NO	PER1SUN	Yes
<b>PER.1→DAYS→HOL</b>	Holiday in Period	YES/NO	PER1HOL	Yes
<b>PER.1→OCC</b>	Occupied from	00:00	PER1_OCC	00:00
<b>PER.1→UNC</b>	Occupied to	00:00	PER1_UNC	24:00
<b>Repeat for periods 2-8</b>				
<b>HOL.L</b>	<b>LOCAL HOLIDAY SCHEDULES</b>			
<b>HD.01</b>	HOLIDAY SCHEDULE 01			
<b>HD.01→MON</b>	Holiday Start Month	0-12	HOL_MON1	
<b>HD.01→DAY</b>	Start Day	0-31	HOL_DAY1	
<b>HD.01→LEN</b>	Duration (Days)	0-99	HOL_LEN1	
<b>Repeat for holidays 2-30</b>				
<b>DAY.S</b>	<b>DAYLIGHT SAVINGS TIME</b>			
<b>DS.ST</b>	DAYLIGHT SAVINGS START			
<b>DS.ST→ST.MN</b>	Month	1 - 12	STARTM	4
<b>DS.ST→ST.WK</b>	Week	1 - 5	STARTW	1
<b>DS.ST→ST.DY</b>	Day	1 - 7	STARTD	7
<b>DS.ST→MIN.A</b>	Minutes to Add	0 - 90	MINADD	60
<b>DS.SP</b>	<b>DAYLIGHTS SAVINGS STOP</b>			
<b>DS.SP→SP.MN</b>	Month	1 - 12	STOPM	10
<b>DS.SP→SP.WK</b>	Week	1 - 5	STOPW	5
<b>DS.SP→SP.DY</b>	Day	1 - 7	STOPD	7
<b>DS.SP→MIN.S</b>	Minutes to Subtract	0 - 90	MINSUB	60

**TROUBLESHOOTING**

The scrolling marquee display shows the actual operating conditions of the unit while it is running. If there are alarms or there have been alarms, they will be displayed in either the current alarm list or the history alarm list. The Service Test mode allows proper operation of the compressors, fans, and other components to be checked while the unit is not operating.

**Complete Unit Stoppage** — There are several conditions that can cause the unit not to provide heating or cooling. If an alarm is active which causes the unit to shut down, diagnose the problem using the information provided in the Alarms and Alerts section on page 94, but also check for the following:

- Cooling and heating loads are satisfied.
- Programmed schedule.
- General power failure.
- Tripped control circuit transformers circuit breakers.
- Tripped compressor circuit breakers.
- Unit is turned off through the CCN network.

**Single Circuit Stoppage** — If a single circuit stops incorrectly, there are several possible causes. The problem should be investigated using information from the Alarms and Alerts section on page 94.

**Service Analysis** — Detailed service analysis can be found in Tables 94-96 and in Fig. 14.

**Restart Procedure** — Before attempting to restart the machine, check the alarm list to determine the cause of the shutdown. If the shutdown alarm for a particular circuit has occurred, determine and correct the cause before allowing the unit to run under its own control again. When there is problem, the unit should be diagnosed in Service Test mode. The alarms must be reset before the circuit can operate in either Normal mode or Service Test mode.

**Thermistor Troubleshooting** — The electronic control uses five 5K-thermistors for the saturated condensing temperature on 48/50AJ,AK,AW,AY units (SCT.A and SCT.B). See Tables 97 and 98 for temperature vs. resistance data.

When replacing thermistors SCT.A and SCT.B, reuse the original hardware. These thermistors must be clamped tightly to the hairpins of the condenser.

The EDT, OAT, RAT, LAT, T55, T56, and T58 space temperature sensors use 10K thermistors. Resistances at various temperatures are listed in Tables 99 and 100.

**THERMISTOR/TEMPERATURE SENSOR CHECK** — A high quality digital volt-ohmmeter is required to perform this check.

1. Connect the digital voltmeter across the appropriate thermistor terminals at the J8 terminal strip on the main base board.
2. Using the voltage reading obtained, read the sensor temperature from Tables 97-100.
3. To check thermistor accuracy, measure temperature at probe location with an accurate thermocouple-type temperature-measuring instrument. Insulate thermocouple to avoid ambient temperatures from influencing reading. Temperature measured by thermocouple and temperature determined from thermistor voltage reading should be close, 5° F (3° C) if care was taken in applying thermocouple and taking readings.

If a more accurate check is required, unit must be shut down and thermistor removed and checked at a known temperature (freezing point or boiling point of water) using either voltage drop measured across thermistor at the J8 terminal, or by determining the resistance with unit shut down and thermistor disconnected from J8. Compare the values determined with the value read by the control in the Temperatures mode using the scrolling marquee display.

**Transducer Troubleshooting** — On 48/50AJ,AK, AW,AY units, the electronic control uses 2 suction pressure transducers to measure the suction pressure of circuits A and B. The pressure/voltage characteristics of these transducers are shown in Tables 101 and 102. On 48/50A2,A3,A4,A5 units, the electronic control uses 4 pressure transducers to measure

the suction and discharge pressure of circuits A and B. The pressure/voltage characteristics of these transducers are shown in Tables 103 and 104. The accuracy of these transducers can be verified by connecting an accurate pressure gage to the second refrigerant port in the suction line.

**Table 94 — Cooling Service Analysis**

PROBLEM	SOLUTION
<b>COMPRESSOR DOES NOT RUN</b> <b>Active Alarm</b>	Check active alarms using local display.
<b>Contactor Open</b> 1. Power off. 2. Fuses blown in field power circuit. 3. No control power.  4. Compressor circuit breaker tripped.  5. Safety device lockout circuit active. 6. High-pressure switch open.  7. Loose electrical connections.	1. Restore power. 2. After finding cause and correcting, replace with correct size fuse. 3. Check secondary fuse(s); replace with correct type and size. Replace transformer if primary windings receiving power. 4. Check for excessive compressor current draw. Reset breaker; replace if defective. 5. Reset lockout circuit at circuit breaker. 6. Check for refrigerant overcharge, obstruction of outdoor airflow, air in system or whether compressor discharge valve is fully open. Be sure outdoor fans are operating correctly. 7. Tighten all connections.
<b>Contactor Closed</b> 1. Compressor leads loose. 2. Motor windings open. 3. Single phasing.  4. ASTP activated (48/50A2,A3,A4,A5 only)	1. Check connections. 2. See compressor service literature. 3. Check for blown fuse. Check for loose connection at compressor terminal. 4. Allow 30 to 120 minutes for cool down. See Compressor Safeties section on page 39.
<b>COMPRESSOR STOPS ON HIGH PRESSURE</b> <b>Outdoor Fan On</b> 1. High-pressure switch faulty. 2. Airflow restricted. 3. Air recirculating. 4. Noncondensables in system. 5. Refrigerant overcharge. 6. Line voltage incorrect. 7. Refrigerant system restrictions.  8. Fan running in reverse direction.	1. Replace switch. 2. Remove obstruction. 3. Clear airflow area. 4. Purge and recharge as required. 5. Purge as required. 6. Consult power company. 7. Check or replace filter drier, expansion valve, etc. Check that compressor discharge valve is fully open. 8. Correct wiring.
<b>Outdoor Fan Off</b> 1. Fan slips on shaft. 2. Motor not running. 3. Motor overload open. 4. Motor burned out.	1. Tighten fan hub setscrews. 2. Check power and capacitor. 3. Check overload rating. Check for fan blade obstruction. 4. Replace motor.
<b>COMPRESSOR CYCLES ON LOW PRESSURE</b> <b>Indoor-Air Fan Running</b> 1. Filter drier plugged. 2. Expansion valve power head defective. 3. Low refrigerant charge. 4. Faulty pressure transducer.	1. Replace filter drier. 2. Replace power head. 3. Add charge. 4. Check that pressure transducer is connected and secured to suction line. If still not functioning, replace transducer.
<b>Airflow Restricted</b> 1. Coil iced up. 2. Coil dirty. 3. Air filters dirty. 4. Dampers closed.	1. Check refrigerant charge. 2. Clean coil fins. 3. Clean or replace filters. 4. Check damper operation and position.
<b>Indoor-Air Fan Stopped</b> 1. Electrical connections loose. 2. Fan relay defective. 3. Motor overload open. 4. Motor defective. 5. Fan belt broken or slipping.	1. Tighten all connections. 2. Replace relay. 3. Power supply. 4. Replace motor. 5. Replace or tighten belt.

LEGEND

**ASTP** — Advanced Scroll Temperature Protection  
**VFD** — Variable Frequency Drive

**Table 94 — Cooling Service Analysis (cont)**

PROBLEM	SOLUTION
<b>COMPRESSOR RUNNING BUT COOLING INSUFFICIENT</b> <u>Suction Pressure Low</u> 1. Refrigerant charge low. 2. Head pressure low. 3. Air filters dirty. 4. Expansion valve power head defective. 5. Indoor coil partially iced. 6. Indoor airflow restricted.	1. Add refrigerant. 2. Check refrigerant charge. 3. Clean or replace filters. 4. Replace power head. 5. Check low-pressure setting. 6. Remove obstruction.
<u>Suction Pressure High</u> Heat load excessive.	Check for open doors or windows.
<b>UNIT OPERATES TOO LONG OR CONTINUOUSLY</b> 1. Low refrigerant charge. 2. Control contacts fused. 3. Air in system. 4. Partially plugged expansion valve or filter drier.	1. Add refrigerant 2. Replace control. 3. Purge and evacuate system. 4. Clean or replace.
<b>SYSTEM IS NOISY</b> 1. Piping vibration. 2. Compressor noisy.	1. Support piping as required. 2. Replace compressor.
<b>COMPRESSOR LOSES OIL</b> 1. Leak in system. 2. Crankcase heaters not energized during shutdown.	1. Repair leak. 2. Check wiring and relays. Check heater and replace if defective.
<b>FROSTED SUCTION LINE</b> Expansion valve admitting excess refrigerant.	Adjust expansion valve.
<b>HOT LIQUID LINE</b> 1. Shortage of refrigerant due to leak. 2. Expansion valve opens too wide.	1. Repair leak and recharge. 2. Adjust expansion valve.
<b>FROSTED LIQUID LINE</b> Restricted filter drier.	Remove restriction or replace.
<b>INDOOR FAN CONTACTOR OPEN</b> 1. Power off. 2. Fuses blown in field power circuit. 3. No control power.	1. Restore power. 2. After finding cause and correcting, replace with correct fuses. 3. Check secondary fuses. Replace with correct type and size. Replace transformer if primary windings are receiving power.
<b>INDOOR FAN CONTACTOR CLOSED</b> 1. VFD overload function tripped.  2. Motor leads loose. 3. Motor windings open. 4. Single phasing.  5. Belts broken or thrown. 6. Circuit breaker tripped.	1. Refer to separate VFD technical manual for troubleshooting instructions. 2. Check connections at motor lead junction box. 3. Check motor windings. 4. Check for blown fuse. Check for loose connections at motor junction box. 5. Check belts. Replace as complete set if necessary. 6. Check for excessive current draw. Reset breaker. Replace if defective.

LEGEND

**ASTP** — Advanced Scroll Temperature Protection  
**VFD** — Variable Frequency Drive

**Table 95 — Gas Heating Service Analysis**

PROBLEM	CAUSE	REMEDY
<b>Burners Will Not Ignite.</b>	Active alarm.	Check active alarms using <i>ComfortLink</i> scrolling marquee.
	No power to unit.	Check power supply, fuses, wiring, and circuit breakers.
	No power to IGC (Integrated Gas Control).	Check fuses and plugs.
	Heaters off due to time guard to prevent short cycling.	Check using <i>ComfortLink</i> scrolling marquee.
	Control calling for Cooling.	Check using <i>ComfortLink</i> scrolling marquee.
	No gas at main burners.	Check gas line for air and purge as necessary. After purging gas line of air, allow gas to dissipate for at least 5 minutes before attempting to re-light unit.
	Water in gas line.	Drain water and install drip.
<b>Inadequate Heating.</b>	Dirty air filters.	Replace air filters.
	Gas input too low.	Check gas pressure at manifold. Refer to gas valve adjustment in Installation, Start-up, and Service Manual.
	Control calling for W1 only (low heat).	Allow time for W2 to energize.
	Unit undersized for load.	Decrease load.
	Restricted airflow.	Remove restriction.
	Too much outdoor air.	Check economizer position and configuration. Adjust minimum position using <i>ComfortLink</i> scrolling marquee.
	Limit switch cycles main burners.	Check rotation of blower, thermostat heat anticipator settings, and temperature rise of unit. Adjust as needed.
<b>Poor Flame Characteristics.</b>	Incomplete combustion (lack of combustion air) results in: Aldehyde odors, CO, sooting flame, or floating flame.	Check all screws around flue outlets and burner compartment. Tighten as necessary.
		Cracked heat exchanger, replace.
		Unit is over-fired, reduce input. Adjust gas line or manifold pressure.
		Check vent for restriction. Clean as necessary.
<b>Burners Will Not Turn Off.</b>	Unit is in minimum on-time.	Check using <i>ComfortLink</i> scrolling marquee.
	Unit running in Service Test mode.	Check using <i>ComfortLink</i> scrolling marquee.

**Table 96 — Electric Heat Service Analysis**

PROBLEM	CAUSE	REMEDY
<b>No Heat.</b>	Power failure.	Call power company.
	Fuse blown or circuit breaker tripped.	Replace fuse or reset circuit breaker.
	Thermostat occupancy schedule set point not calling for Heating.	Check using <i>ComfortLink</i> scrolling marquee.
	No 24 vac at primary contactor.	Check transformer and circuit breaker.
	No power (high voltage) to L2 of primary contactor.	Check safety switches “one-shot” backup and auto limit.
	Bad electrical elements.	Power off unit and remove high voltage wires. Check resistance of heater, replace if open.

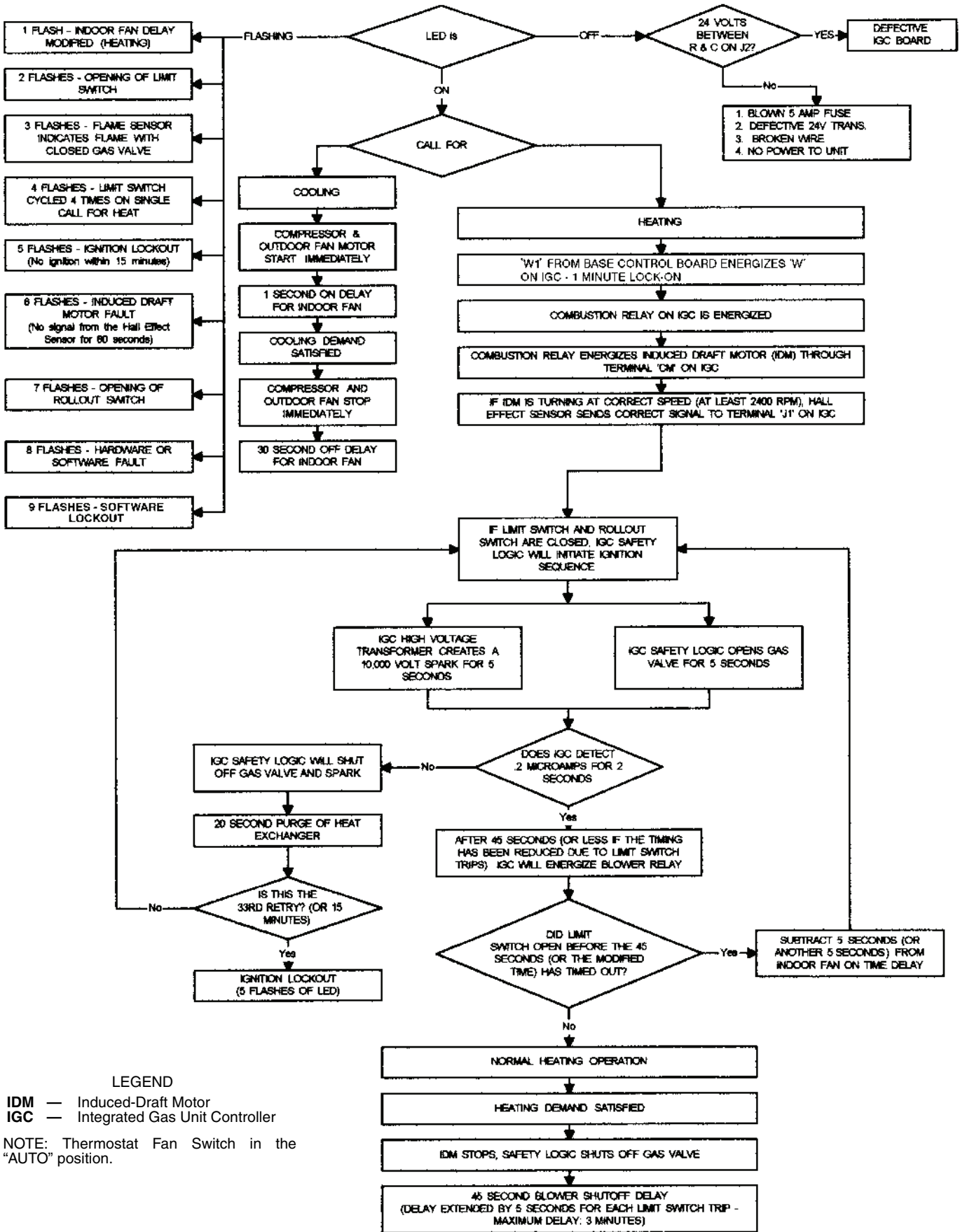


Fig. 14 — IGC Service Analysis Logic

Table 97 — 5K Thermistor Temperature vs. Resistance (SCT Sensors) (English)

TEMP (F)	VOLTAGE DROP (V)	RESISTANCE (Ohms)	TEMP (F)	VOLTAGE DROP (V)	RESISTANCE (Ohms)	TEMP (F)	VOLTAGE DROP (V)	RESISTANCE (Ohms)
-25	3.699	98,010	59	1.982	7,686	143	0.511	1,190
-24	3.689	94,707	60	1.956	7,665	144	0.502	1,165
-23	3.679	91,522	61	1.930	7,468	145	0.494	1,141
-22	3.668	88,449	62	1.905	7,277	146	0.485	1,118
-21	3.658	85,486	63	1.879	7,091	147	0.477	1,095
-20	3.647	82,627	64	1.854	6,911	148	0.469	1,072
-19	3.636	79,871	65	1.829	6,735	149	0.461	1,050
-18	3.624	77,212	66	1.804	6,564	150	0.453	1,029
-17	3.613	74,648	67	1.779	6,399	151	0.445	1,007
-16	3.601	72,175	68	1.754	6,238	152	0.438	986
-15	3.588	69,790	69	1.729	6,081	153	0.430	965
-14	3.576	67,490	70	1.705	5,929	154	0.423	945
-13	3.563	65,272	71	1.681	5,781	155	0.416	925
-12	3.550	63,133	72	1.656	5,637	156	0.408	906
-11	3.536	61,070	73	1.632	5,497	157	0.402	887
-10	3.523	59,081	74	1.609	5,361	158	0.395	868
-9	3.509	57,162	75	1.585	5,229	159	0.388	850
-8	3.494	55,311	76	1.562	5,101	160	0.381	832
-7	3.480	53,526	77	1.538	4,976	161	0.375	815
-6	3.465	51,804	78	1.516	4,855	162	0.369	798
-5	3.450	50,143	79	1.493	4,737	163	0.362	782
-4	3.434	48,541	80	1.470	4,622	164	0.356	765
-3	3.418	46,996	81	1.448	4,511	165	0.350	750
-2	3.402	45,505	82	1.426	4,403	166	0.344	734
-1	3.386	44,066	83	1.404	4,298	167	0.339	719
0	3.369	42,679	84	1.382	4,196	168	0.333	705
1	3.352	41,339	85	1.361	4,096	169	0.327	690
2	3.335	40,047	86	1.340	4,000	170	0.322	677
3	3.317	38,800	87	1.319	3,906	171	0.317	663
4	3.299	37,596	88	1.298	3,814	172	0.311	650
5	3.281	36,435	89	1.278	3,726	173	0.306	638
6	3.262	35,313	90	1.257	3,640	174	0.301	626
7	3.243	34,231	91	1.237	3,556	175	0.296	614
8	3.224	33,185	92	1.217	3,474	176	0.291	602
9	3.205	32,176	93	1.198	3,395	177	0.286	591
10	3.185	31,202	94	1.179	3,318	178	0.282	581
11	3.165	30,260	95	1.160	3,243	179	0.277	570
12	3.145	29,351	96	1.141	3,170	180	0.272	561
13	3.124	28,473	97	1.122	3,099	181	0.268	551
14	3.103	27,624	98	1.104	3,031	182	0.264	542
15	3.082	26,804	99	1.086	2,964	183	0.259	533
16	3.060	26,011	100	1.068	2,898	184	0.255	524
17	3.038	25,245	101	1.051	2,835	185	0.251	516
18	3.016	24,505	102	1.033	2,773	186	0.247	508
19	2.994	23,789	103	1.016	2,713	187	0.243	501
20	2.972	23,096	104	0.999	2,655	188	0.239	494
21	2.949	22,427	105	0.983	2,597	189	0.235	487
22	2.926	21,779	106	0.966	2,542	190	0.231	480
23	2.903	21,153	107	0.950	2,488	191	0.228	473
24	2.879	20,547	108	0.934	2,436	192	0.224	467
25	2.856	19,960	109	0.918	2,385	193	0.220	461
26	2.832	19,393	110	0.903	2,335	194	0.217	456
27	2.808	18,843	111	0.888	2,286	195	0.213	450
28	2.784	18,311	112	0.873	2,239	196	0.210	445
29	2.759	17,796	113	0.858	2,192	197	0.206	439
30	2.735	17,297	114	0.843	2,147	198	0.203	434
31	2.710	16,814	115	0.829	2,103	199	0.200	429
32	2.685	16,346	116	0.815	2,060	200	0.197	424
33	2.660	15,892	117	0.801	2,018	201	0.194	419
34	2.634	15,453	118	0.787	1,977	202	0.191	415
35	2.609	15,027	119	0.774	1,937	203	0.188	410
36	2.583	14,614	120	0.761	1,898	204	0.185	405
37	2.558	14,214	121	0.748	1,860	205	0.182	401
38	2.532	13,826	122	0.735	1,822	206	0.179	396
39	2.506	13,449	123	0.723	1,786	207	0.176	391
40	2.480	13,084	124	0.710	1,750	208	0.173	386
41	2.454	12,730	125	0.698	1,715	209	0.171	382
42	2.428	12,387	126	0.686	1,680	210	0.168	377
43	2.402	12,053	127	0.674	1,647	211	0.165	372
44	2.376	11,730	128	0.663	1,614	212	0.163	367
45	2.349	11,416	129	0.651	1,582	213	0.160	361
46	2.323	11,112	130	0.640	1,550	214	0.158	356
47	2.296	10,816	131	0.629	1,519	215	0.155	350
48	2.270	10,529	132	0.618	1,489	216	0.153	344
49	2.244	10,250	133	0.608	1,459	217	0.151	338
50	2.217	9,979	134	0.597	1,430	218	0.148	332
51	2.191	9,717	135	0.587	1,401	219	0.146	325
52	2.165	9,461	136	0.577	1,373	220	0.144	318
53	2.138	9,213	137	0.567	1,345	221	0.142	311
54	2.112	8,973	138	0.557	1,318	222	0.140	304
55	2.086	8,739	139	0.548	1,291	223	0.138	297
56	2.060	8,511	140	0.538	1,265	224	0.135	289
57	2.034	8,291	141	0.529	1,240	225	0.133	282
58	2.008	8,076	142	0.520	1,214			

**Table 98 — 5K Thermistor Temperature vs. Resistance (SCT Sensors) (SI)**

TEMP (C)	VOLTAGE DROP (V)	RESISTANCE (Ohms)	TEMP (C)	VOLTAGE DROP (V)	RESISTANCE (Ohms)	TEMP (C)	VOLTAGE DROP (V)	RESISTANCE (Ohms)
-32	3.705	100,260	15	1.982	7,855	62	0.506	1,158
-31	3.687	94,165	16	1.935	7,499	63	0.490	1,118
-30	3.668	88,480	17	1.889	7,161	64	0.475	1,079
-29	3.649	83,170	18	1.844	6,840	65	0.461	1,041
-28	3.629	78,125	19	1.799	6,536	66	0.447	1,006
-27	3.608	73,580	20	1.754	6,246	67	0.433	971
-26	3.586	69,250	21	1.710	5,971	68	0.420	938
-25	3.563	65,205	22	1.666	5,710	69	0.407	906
-24	3.539	61,420	23	1.623	5,461	70	0.395	876
-23	3.514	57,875	24	1.580	5,225	71	0.383	836
-22	3.489	54,555	25	1.538	5,000	72	0.371	805
-21	3.462	51,450	26	1.497	4,786	73	0.360	775
-20	3.434	48,536	27	1.457	4,583	74	0.349	747
-19	3.406	45,807	28	1.417	4,389	75	0.339	719
-18	3.376	43,247	29	1.378	4,204	76	0.329	693
-17	3.345	40,845	30	1.340	4,028	77	0.319	669
-16	3.313	38,592	31	1.302	3,861	78	0.309	645
-15	3.281	38,476	32	1.265	3,701	79	0.300	623
-14	3.247	34,489	33	1.229	3,549	80	0.291	602
-13	3.212	32,621	34	1.194	3,404	81	0.283	583
-12	3.177	30,866	35	1.160	3,266	82	0.274	564
-11	3.140	29,216	36	1.126	3,134	83	0.266	547
-10	3.103	27,633	37	1.093	3,008	84	0.258	531
-9	3.065	26,202	38	1.061	2,888	85	0.251	516
-8	3.025	24,827	39	1.030	2,773	86	0.244	502
-7	2.985	23,532	40	0.999	2,663	87	0.237	489
-6	2.945	22,313	41	0.969	2,559	88	0.230	477
-5	2.903	21,163	42	0.940	2,459	89	0.223	466
-4	2.860	20,079	43	0.912	2,363	90	0.217	456
-3	2.817	19,058	44	0.885	2,272	91	0.211	446
-2	2.774	18,094	45	0.858	2,184	92	0.204	436
-1	2.730	17,184	46	0.832	2,101	93	0.199	427
0	2.685	16,325	47	0.807	2,021	94	0.193	419
1	2.639	15,515	48	0.782	1,944	95	0.188	410
2	2.593	14,749	49	0.758	1,871	96	0.182	402
3	2.547	14,026	50	0.735	1,801	97	0.177	393
4	2.500	13,342	51	0.713	1,734	98	0.172	385
5	2.454	12,696	52	0.691	1,670	99	0.168	376
6	2.407	12,085	53	0.669	1,609	100	0.163	367
7	2.360	11,506	54	0.649	1,550	101	0.158	357
8	2.312	10,959	55	0.629	1,493	102	0.154	346
9	2.265	10,441	56	0.610	1,439	103	0.150	335
10	2.217	9,949	57	0.591	1,387	104	0.146	324
11	2.170	9,485	58	0.573	1,337	105	0.142	312
12	2.123	9,044	59	0.555	1,290	106	0.138	299
13	2.076	8,627	60	0.538	1,244	107	0.134	285
14	2.029	8,231	61	0.522	1,200			



Table 99 — 10K Thermistor vs. Resistance (T55, T56, OAT, RAT, EDT, LAT Sensors) (English)

TEMP (F)	VOLTAGE DROP (V)	RESISTANCE (Ohms)	TEMP (F)	VOLTAGE DROP (V)	RESISTANCE (Ohms)	TEMP (F)	VOLTAGE DROP (V)	RESISTANCE (Ohms)
-25	4.758	196,453	61	2.994	14,925	147	0.890	2,166
-24	4.750	189,692	62	2.963	14,549	148	0.876	2,124
-23	4.741	183,300	63	2.932	14,180	149	0.862	2,083
-22	4.733	177,000	64	2.901	13,824	150	0.848	2,043
-21	4.724	171,079	65	2.870	13,478	151	0.835	2,003
-20	4.715	165,238	66	2.839	13,139	152	0.821	1,966
-19	4.705	159,717	67	2.808	12,814	153	0.808	1,928
-18	4.696	154,344	68	2.777	12,493	154	0.795	1,891
-17	4.686	149,194	69	2.746	12,187	155	0.782	1,855
-16	4.676	144,250	70	2.715	11,884	156	0.770	1,820
-15	4.665	139,443	71	2.684	11,593	157	0.758	1,786
-14	4.655	134,891	72	2.653	11,308	158	0.745	1,752
-13	4.644	130,402	73	2.622	11,031	159	0.733	1,719
-12	4.633	126,183	74	2.592	10,764	160	0.722	1,687
-11	4.621	122,018	75	2.561	10,501	161	0.710	1,656
-10	4.609	118,076	76	2.530	10,249	162	0.699	1,625
-9	4.597	114,236	77	2.500	10,000	163	0.687	1,594
-8	4.585	110,549	78	2.470	9,762	164	0.676	1,565
-7	4.572	107,006	79	2.439	9,526	165	0.666	1,536
-6	4.560	103,558	80	2.409	9,300	166	0.655	1,508
-5	4.546	100,287	81	2.379	9,078	167	0.645	1,480
-4	4.533	97,060	82	2.349	8,862	168	0.634	1,453
-3	4.519	94,020	83	2.319	8,653	169	0.624	1,426
-2	4.505	91,019	84	2.290	8,448	170	0.614	1,400
-1	4.490	88,171	85	2.260	8,251	171	0.604	1,375
0	4.476	85,396	86	2.231	8,056	172	0.595	1,350
1	4.461	82,729	87	2.202	7,869	173	0.585	1,326
2	4.445	80,162	88	2.173	7,685	174	0.576	1,302
3	4.429	77,662	89	2.144	7,507	175	0.567	1,278
4	4.413	75,286	90	2.115	7,333	176	0.558	1,255
5	4.397	72,940	91	2.087	7,165	177	0.549	1,233
6	4.380	70,727	92	2.059	6,999	178	0.540	1,211
7	4.363	68,542	93	2.030	6,838	179	0.532	1,190
8	4.346	66,465	94	2.003	6,683	180	0.523	1,169
9	4.328	64,439	95	1.975	6,530	181	0.515	1,148
10	4.310	62,491	96	1.948	6,383	182	0.507	1,128
11	4.292	60,612	97	1.921	6,238	183	0.499	1,108
12	4.273	58,781	98	1.894	6,098	184	0.491	1,089
13	4.254	57,039	99	1.867	5,961	185	0.483	1,070
14	4.235	55,319	100	1.841	5,827	186	0.476	1,052
15	4.215	53,693	101	1.815	5,698	187	0.468	1,033
16	4.195	52,086	102	1.789	5,571	188	0.461	1,016
17	4.174	50,557	103	1.763	5,449	189	0.454	999
18	4.153	49,065	104	1.738	5,327	190	0.447	981
19	4.132	47,627	105	1.713	5,210	191	0.440	964
20	4.111	46,240	106	1.688	5,095	192	0.433	947
21	4.089	44,888	107	1.663	4,984	193	0.426	931
22	4.067	43,598	108	1.639	4,876	194	0.419	915
23	4.044	42,324	109	1.615	4,769	195	0.413	900
24	4.021	41,118	110	1.591	4,666	196	0.407	885
25	3.998	39,926	111	1.567	4,564	197	0.400	870
26	3.975	38,790	112	1.544	4,467	198	0.394	855
27	3.951	37,681	113	1.521	4,370	199	0.388	841
28	3.927	36,610	114	1.498	4,277	200	0.382	827
29	3.903	35,577	115	1.475	4,185	201	0.376	814
30	3.878	34,569	116	1.453	4,096	202	0.370	800
31	3.853	33,606	117	1.431	4,008	203	0.365	787
32	3.828	32,654	118	1.409	3,923	204	0.359	774
33	3.802	31,752	119	1.387	3,840	205	0.354	762
34	3.776	30,860	120	1.366	3,759	206	0.349	749
35	3.750	30,009	121	1.345	3,681	207	0.343	737
36	3.723	29,177	122	1.324	3,603	208	0.338	725
37	3.697	28,373	123	1.304	3,529	209	0.333	714
38	3.670	27,597	124	1.284	3,455	210	0.328	702
39	3.654	26,838	125	1.264	3,383	211	0.323	691
40	3.615	26,113	126	1.244	3,313	212	0.318	680
41	3.587	25,396	127	1.225	3,244	213	0.314	670
42	3.559	24,715	128	1.206	3,178	214	0.309	659
43	3.531	24,042	129	1.187	3,112	215	0.305	649
44	3.503	23,399	130	1.168	3,049	216	0.300	639
45	3.474	22,770	131	1.150	2,986	217	0.296	629
46	3.445	22,161	132	1.132	2,926	218	0.292	620
47	3.416	21,573	133	1.114	2,866	219	0.288	610
48	3.387	20,998	134	1.096	2,809	220	0.284	601
49	3.357	20,447	135	1.079	2,752	221	0.279	592
50	3.328	19,903	136	1.062	2,697	222	0.275	583
51	3.298	19,386	137	1.045	2,643	223	0.272	574
52	3.268	18,874	138	1.028	2,590	224	0.268	566
53	3.238	18,384	139	1.012	2,539	225	0.264	557
54	3.208	17,904	140	0.996	2,488			
55	3.178	17,441	141	0.980	2,439			
56	3.147	16,991	142	0.965	2,391			
57	3.117	16,552	143	0.949	2,343			
58	3.086	16,131	144	0.934	2,297			
59	3.056	15,714	145	0.919	2,253			
60	3.025	15,317	146	0.905	2,209			

**Table 100 — 10K Thermistor vs. Resistance (T55, T56, OAT, RAT, EDT, LAT Sensors) (SI)**

TEMP (C)	VOLTAGE DROP (V)	RESISTANCE (Ohms)	TEMP (C)	VOLTAGE DROP (V)	RESISTANCE (Ohms)	TEMP (C)	VOLTAGE DROP (V)	RESISTANCE (Ohms)
-32	4.762	200,510	15	3.056	15,714	62	0.940	2,315
-31	4.748	188,340	16	3.000	15,000	63	0.913	2,235
-30	4.733	177,000	17	2.944	14,323	64	0.887	2,157
-29	4.716	166,342	18	2.889	13,681	65	0.862	2,083
-28	4.700	156,404	19	2.833	13,071	66	0.837	2,011
-27	4.682	147,134	20	2.777	12,493	67	0.813	1,943
-26	4.663	138,482	21	2.721	11,942	68	0.790	1,876
-25	4.644	130,402	22	2.666	11,418	69	0.767	1,813
-24	4.624	122,807	23	2.610	10,921	70	0.745	1,752
-23	4.602	115,710	24	2.555	10,449	71	0.724	1,693
-22	4.580	109,075	25	2.500	10,000	72	0.703	1,637
-21	4.557	102,868	26	2.445	9,571	73	0.683	1,582
-20	4.533	97,060	27	2.391	9,164	74	0.663	1,530
-19	4.508	91,588	28	2.337	8,776	75	0.645	1,480
-18	4.482	86,463	29	2.284	8,407	76	0.626	1,431
-17	4.455	81,662	30	2.231	8,056	77	0.608	1,385
-16	4.426	77,162	31	2.178	7,720	78	0.591	1,340
-15	4.397	72,940	32	2.127	7,401	79	0.574	1,297
-14	4.367	68,957	33	2.075	7,096	80	0.558	1,255
-13	4.335	65,219	34	2.025	6,806	81	0.542	1,215
-12	4.303	61,711	35	1.975	6,530	82	0.527	1,177
-11	4.269	58,415	36	1.926	6,266	83	0.512	1,140
-10	4.235	55,319	37	1.878	6,014	84	0.497	1,104
-9	4.199	52,392	38	1.830	5,774	85	0.483	1,070
-8	4.162	49,640	39	1.784	5,546	86	0.470	1,037
-7	4.124	47,052	40	1.738	5,327	87	0.457	1,005
-6	4.085	44,617	41	1.692	5,117	88	0.444	974
-5	4.044	42,324	42	1.648	4,918	89	0.431	944
-4	4.003	40,153	43	1.605	4,727	90	0.419	915
-3	3.961	38,109	44	1.562	4,544	91	0.408	889
-2	3.917	36,182	45	1.521	4,370	92	0.396	861
-1	3.873	34,367	46	1.480	4,203	93	0.386	836
0	3.828	32,654	47	1.439	4,042	94	0.375	811
1	3.781	31,030	48	1.400	3,889	95	0.365	787
2	3.734	29,498	49	1.362	3,743	96	0.355	764
3	3.686	28,052	50	1.324	3,603	97	0.345	742
4	3.637	26,686	51	1.288	3,469	98	0.336	721
5	3.587	25,396	52	1.252	3,340	99	0.327	700
6	3.537	24,171	53	1.217	3,217	100	0.318	680
7	3.485	23,013	54	1.183	3,099	101	0.310	661
8	3.433	21,918	55	1.150	2,986	102	0.302	643
9	3.381	20,883	56	1.117	2,878	103	0.294	626
10	3.328	19,903	57	1.086	2,774	104	0.287	609
11	3.274	18,972	58	1.055	2,675	105	0.279	592
12	3.220	18,090	59	1.025	2,579	106	0.272	576
13	3.165	17,255	60	0.996	2,488	107	0.265	561
14	3.111	16,474	61	0.968	2,400			

**Table 101 — Suction Pressure Transducer Pressure (PSIG) vs. Voltage (SP-A, SP-B, SP.XR=0, 48/50AJ,AK,AW,AY Units Only)**

PRESSURE (PSIG)	VOLTAGE DROP (V)	PRESSURE (PSIG)	VOLTAGE DROP (V)	PRESSURE (PSIG)	VOLTAGE DROP (V)	PRESSURE (PSIG)	VOLTAGE DROP (V)
0	0.290	34	1.436	68	2.582	102	3.728
1	0.324	35	1.470	69	2.615	103	3.761
2	0.357	36	1.503	70	2.649	104	3.795
3	0.391	37	1.537	71	2.683	105	3.829
4	0.425	38	1.571	72	2.717	106	3.862
5	0.458	39	1.604	73	2.750	107	3.896
6	0.492	40	1.638	74	2.784	108	3.930
7	0.526	41	1.672	75	2.818	109	3.964
8	0.560	42	1.705	76	2.851	110	3.997
9	0.593	43	1.739	77	2.885	111	4.031
10	0.627	44	1.773	78	2.919	112	4.065
11	0.661	45	1.807	79	2.952	113	4.098
12	0.694	46	1.840	80	2.986	114	4.132
13	0.728	47	1.874	81	3.020	115	4.166
14	0.762	48	1.908	82	3.054	116	4.200
15	0.795	49	1.941	83	3.087	117	4.233
16	0.829	50	1.975	84	3.121	118	4.267
17	0.863	51	2.009	85	3.155	119	4.301
18	0.897	52	2.042	86	3.188	120	4.334
19	0.930	53	2.076	87	3.222	121	4.368
20	0.964	54	2.110	88	3.256	122	4.402
21	0.998	55	2.144	89	3.290	123	4.435
22	1.031	56	2.177	90	3.323	124	4.469
23	1.065	57	2.211	91	3.357	125	4.503
24	1.099	58	2.245	92	3.391	126	4.537
25	1.132	59	2.278	93	3.424	127	4.570
26	1.166	60	2.312	94	3.458	128	4.604
27	1.200	61	2.346	95	3.492	129	4.638
28	1.234	62	2.380	96	3.525	130	4.671
29	1.267	63	2.413	97	3.559	131	4.705
30	1.301	64	2.447	98	3.593	132	4.739
31	1.335	65	2.481	99	3.627	133	4.772
32	1.368	66	2.514	100	3.660	134	4.806
33	1.402	67	2.548	101	3.694	135	4.840

**Table 102 — Suction Pressure Transducer Pressure (PSIG) vs. Voltage (SP-A, SP-B, SP.XR = 1,  
48/50AJ,AK,AW,AY Units Only)**

<b>PRESSURE (PSIG)</b>	<b>VOLTAGE DROP (V)</b>	<b>PRESSURE (PSIG)</b>	<b>VOLTAGE DROP (V)</b>	<b>PRESSURE (PSIG)</b>	<b>VOLTAGE DROP (V)</b>	<b>PRESSURE (PSIG)</b>	<b>VOLTAGE DROP (V)</b>
0	0.500	51	1.520	101	2.520	151	3.520
1	0.520	52	1.540	102	2.540	152	3.540
2	0.540	53	1.560	103	2.560	153	3.560
3	0.560	54	1.580	104	2.580	154	3.580
4	0.580	55	1.600	105	2.600	155	3.600
5	0.600	56	1.620	106	2.620	156	3.620
6	0.620	57	1.640	107	2.640	157	3.640
7	0.640	58	1.660	108	2.660	158	3.660
8	0.660	59	1.680	109	2.680	159	3.680
9	0.680	60	1.700	110	2.700	160	3.700
10	0.700	61	1.720	111	2.720	161	3.720
11	0.720	62	1.740	112	2.740	162	3.740
12	0.740	63	1.760	113	2.760	163	3.760
13	0.760	64	1.780	114	2.780	164	3.780
14	0.780	65	1.800	115	2.800	165	3.800
15	0.800	66	1.820	116	2.820	166	3.820
16	0.820	67	1.840	117	2.840	167	3.840
17	0.840	68	1.860	118	2.860	168	3.860
18	0.860	69	1.880	119	2.880	169	3.880
19	0.880	70	1.900	120	2.900	170	3.900
20	0.900	71	1.920	121	2.920	171	3.920
21	0.920	72	1.940	122	2.940	172	3.940
22	0.940	73	1.960	123	2.960	173	3.960
23	0.960	74	1.980	124	2.980	174	3.980
24	0.980	75	2.000	125	3.000	175	4.000
25	1.000	76	2.020	126	3.020	176	4.020
26	1.020	77	2.040	127	3.040	177	4.040
27	1.040	78	2.060	128	3.060	178	4.060
28	1.060	79	2.080	129	3.080	179	4.080
29	1.080	80	2.100	130	3.100	180	4.100
30	1.100	81	2.120	131	3.120	181	4.120
31	1.120	82	2.140	132	3.140	182	4.140
32	1.140	83	2.160	133	3.160	183	4.160
33	1.160	84	2.180	134	3.180	184	4.180
34	1.180	85	2.200	135	3.200	185	4.200
35	1.200	86	2.220	136	3.220	186	4.220
36	1.220	87	2.240	137	3.240	187	4.240
37	1.240	88	2.260	138	3.260	188	4.260
38	1.260	89	2.280	139	3.280	189	4.280
39	1.280	90	2.300	140	3.300	190	4.300
40	1.300	91	2.320	141	3.320	191	4.320
41	1.320	92	2.340	142	3.340	192	4.340
42	1.340	93	2.360	143	3.360	193	4.360
43	1.360	94	2.380	144	3.380	194	4.380
44	1.380	95	2.400	145	3.400	195	4.400
45	1.400	96	2.420	146	3.420	196	4.420
46	1.420	97	2.440	147	3.440	197	4.440
47	1.440	98	2.460	148	3.460	198	4.460
48	1.460	99	2.480	149	3.480	199	4.480
49	1.480	100	2.500	150	3.500	200	4.500
50	1.500						

**Table 103 — Suction Pressure Transducer (PSIG) vs. Voltage (SP-A, SP-B, 48/50A2,A3,A4,A5 Units Only)**

PRESSURE (PSIG)	VOLTAGE DROP (V)	PRESSURE (PSIG)	VOLTAGE DROP (V)	PRESSURE (PSIG)	VOLTAGE DROP (V)	PRESSURE (PSIG)	VOLTAGE DROP (V)
0	0.466	106	1.509	211	2.543	316	3.576
1	0.476	107	1.519	212	2.553	317	3.586
2	0.486	108	1.529	213	2.562	318	3.596
3	0.495	109	1.539	214	2.572	319	3.606
4	0.505	110	1.549	215	2.582	320	3.616
5	0.515	111	1.558	216	2.592	321	3.626
6	0.525	112	1.568	217	2.602	322	3.635
7	0.535	113	1.578	218	2.612	323	3.645
8	0.545	114	1.588	219	2.622	324	3.655
9	0.554	115	1.598	220	2.631	325	3.665
10	0.564	116	1.608	221	2.641	326	3.675
11	0.574	117	1.618	222	2.651	327	3.685
12	0.584	118	1.627	223	2.661	328	3.694
13	0.594	119	1.637	224	2.671	329	3.704
14	0.604	120	1.647	225	2.681	330	3.714
15	0.614	121	1.657	226	2.690	331	3.724
16	0.623	122	1.667	227	2.700	332	3.734
17	0.633	123	1.677	228	2.710	333	3.744
18	0.643	124	1.686	229	2.720	334	3.753
19	0.653	125	1.696	230	2.730	335	3.763
20	0.663	126	1.706	231	2.740	336	3.773
21	0.673	127	1.716	232	2.749	337	3.783
22	0.682	128	1.726	233	2.759	338	3.793
23	0.692	129	1.736	234	2.769	339	3.803
24	0.702	130	1.745	235	2.779	340	3.813
25	0.712	131	1.755	236	2.789	341	3.822
26	0.722	132	1.765	237	2.799	342	3.832
27	0.732	133	1.775	238	2.809	343	3.842
28	0.741	134	1.785	239	2.818	344	3.852
29	0.751	135	1.795	240	2.828	345	3.862
30	0.761	136	1.805	241	2.838	346	3.872
31	0.771	137	1.814	242	2.848	347	3.881
32	0.781	138	1.824	243	2.858	348	3.891
33	0.791	139	1.834	244	2.868	349	3.901
34	0.801	140	1.844	245	2.877	350	3.911
35	0.810	141	1.854	246	2.887	351	3.921
36	0.820	142	1.864	247	2.897	352	3.931
37	0.830	143	1.873	248	2.907	353	3.940
38	0.840	144	1.883	249	2.917	354	3.950
39	0.850	145	1.893	250	2.927	355	3.960
40	0.860	146	1.903	251	2.936	356	3.970
41	0.869	147	1.913	252	2.946	357	3.980
42	0.879	148	1.923	253	2.956	358	3.990
43	0.889	149	1.932	254	2.966	359	4.000
44	0.899	150	1.942	255	2.976	360	4.009
45	0.909	151	1.952	256	2.986	361	4.019
46	0.919	152	1.962	257	2.996	362	4.029
47	0.928	153	1.972	258	3.005	363	4.039
48	0.938	154	1.982	259	3.015	364	4.049
49	0.948	155	1.992	260	3.025	365	4.059
50	0.958	156	2.001	261	3.035	366	4.068
51	0.968	157	2.011	262	3.045	367	4.078
52	0.978	158	2.021	263	3.055	368	4.088
53	0.988	159	2.031	264	3.064	369	4.098
54	0.997	160	2.041	265	3.074	370	4.108
55	1.007	161	2.051	266	3.084	371	4.118
56	1.017	162	2.060	267	3.094	372	4.128
57	1.027	163	2.070	268	3.104	373	4.137
58	1.037	164	2.080	269	3.114	374	4.147
59	1.047	165	2.090	270	3.124	375	4.157
60	1.056	166	2.100	271	3.133	376	4.167
61	1.066	167	2.110	272	3.143	377	4.177
62	1.076	168	2.120	273	3.153	378	4.187
63	1.086	169	2.129	274	3.163	379	4.196
64	1.096	170	2.139	275	3.173	380	4.206
65	1.106	171	2.149	276	3.183	381	4.216
66	1.116	172	2.159	277	3.192	382	4.226
67	1.125	173	2.169	278	3.202	383	4.236
68	1.135	174	2.179	279	3.212	384	4.246
69	1.145	175	2.188	280	3.222	385	4.255
70	1.155	176	2.198	281	3.232	386	4.265
71	1.165	177	2.208	282	3.242	387	4.275
72	1.175	178	2.218	283	3.251	388	4.285
73	1.184	179	2.228	284	3.261	389	4.295
74	1.194	180	2.238	285	3.271	390	4.305
75	1.204	181	2.247	286	3.281	391	4.315
76	1.214	182	2.257	287	3.291	392	4.324
77	1.224	183	2.267	288	3.301	393	4.334
78	1.234	184	2.277	289	3.311	394	4.344
79	1.243	185	2.287	290	3.320	395	4.354
80	1.253	186	2.297	291	3.330	396	4.364
81	1.263	187	2.307	292	3.340	397	4.374
82	1.273	188	2.316	293	3.350	398	4.383
83	1.283	189	2.326	294	3.360	399	4.393
84	1.293	190	2.336	295	3.370	400	4.403
85	1.303	191	2.346	296	3.379	401	4.413
86	1.312	192	2.356	297	3.389	402	4.423
87	1.322	193	2.366	298	3.399	403	4.433
88	1.332	194	2.375	299	3.409	404	4.442
89	1.342	195	2.385	300	3.419	405	4.452
90	1.352	196	2.395	301	3.429	406	4.462
91	1.362	197	2.405	302	3.438	407	4.472
92	1.371	198	2.415	303	3.448	408	4.482
93	1.381	199	2.425	304	3.458	409	4.492
94	1.391	200	2.434	305	3.468	410	4.502
95	1.401	201	2.444	306	3.478	411	4.511
96	1.411	202	2.454	307	3.488	412	4.521
97	1.421	203	2.464	308	3.498	413	4.531
98	1.430	204	2.474	309	3.507	414	4.541
99	1.440	205	2.484	310	3.517	415	4.551
100	1.450	206	2.494	311	3.527	416	4.561
101	1.460	207	2.503	312	3.537	417	4.570
102	1.470	208	2.513	313	3.547	418	4.580
103	1.480	209	2.523	314	3.557	419	4.590
104	1.490	210	2.533	315	3.566	420	4.600
105	1.499						

**Table 104 — Discharge Pressure Transducer (PSIG) vs. Voltage (DP-A, DP-B, 48/50A2,A3,A4,A5 Units Only)**

<b>PRESSURE (PSIG)</b>	<b>VOLTAGE DROP (V)</b>	<b>PRESSURE (PSIG)</b>	<b>VOLTAGE DROP (V)</b>	<b>PRESSURE (PSIG)</b>	<b>VOLTAGE DROP (V)</b>	<b>PRESSURE (PSIG)</b>	<b>VOLTAGE DROP (V)</b>
14.5	0.500	95	0.993	176	1.490	257	1.987
16	0.509	96	1.000	177	1.496	258	1.993
17	0.515	97	1.006	178	1.502	259	1.999
18	0.521	98	1.012	179	1.508	260	2.005
19	0.528	99	1.018	180	1.515	261	2.011
20	0.534	100	1.024	181	1.521	262	2.017
21	0.540	101	1.030	182	1.527	263	2.023
22	0.546	102	1.036	183	1.533	264	2.029
23	0.552	103	1.043	184	1.539	265	2.036
24	0.558	104	1.049	185	1.545	266	2.042
25	0.564	105	1.055	186	1.551	267	2.048
26	0.570	106	1.061	187	1.557	268	2.054
27	0.577	107	1.067	188	1.564	269	2.060
28	0.583	108	1.073	189	1.570	270	2.066
29	0.589	109	1.079	190	1.576	271	2.072
30	0.595	110	1.085	191	1.582	272	2.079
31	0.601	111	1.092	192	1.588	273	2.085
32	0.607	112	1.098	193	1.594	274	2.091
33	0.613	113	1.104	194	1.600	275	2.097
34	0.620	114	1.110	195	1.606	276	2.103
35	0.626	115	1.116	196	1.613	277	2.109
35	0.626	116	1.122	197	1.619	278	2.115
36	0.632	117	1.128	198	1.625	279	2.121
37	0.638	118	1.134	199	1.631	280	2.128
38	0.644	119	1.141	200	1.637	281	2.134
39	0.650	120	1.147	201	1.643	282	2.140
40	0.656	121	1.153	202	1.649	283	2.146
41	0.662	122	1.159	203	1.656	284	2.152
42	0.669	123	1.165	204	1.662	285	2.158
43	0.675	124	1.171	205	1.668	286	2.164
44	0.681	125	1.177	206	1.674	287	2.170
45	0.687	126	1.184	207	1.680	288	2.177
46	0.693	127	1.190	208	1.686	289	2.183
47	0.699	128	1.196	209	1.692	290	2.189
48	0.705	129	1.202	210	1.698	291	2.195
49	0.711	130	1.208	211	1.705	292	2.201
50	0.718	131	1.214	212	1.711	293	2.207
51	0.724	132	1.220	213	1.717	294	2.213
52	0.730	133	1.226	214	1.723	295	2.220
53	0.736	134	1.233	215	1.729	296	2.226
54	0.742	135	1.239	216	1.735	297	2.232
55	0.748	136	1.245	217	1.741	298	2.238
56	0.754	137	1.251	218	1.747	299	2.244
57	0.761	138	1.257	219	1.754	300	2.250
58	0.767	139	1.263	220	1.760	301	2.256
59	0.773	140	1.269	221	1.766	302	2.262
60	0.779	141	1.275	222	1.772	303	2.269
61	0.785	142	1.282	223	1.778	304	2.275
62	0.791	143	1.288	224	1.784	305	2.281
63	0.797	144	1.294	225	1.790	306	2.287
64	0.803	145	1.300	226	1.797	307	2.293
65	0.810	146	1.306	227	1.803	308	2.299
66	0.816	147	1.312	228	1.809	309	2.305
67	0.822	148	1.318	229	1.815	310	2.311
68	0.828	149	1.325	230	1.821	311	2.318
69	0.834	150	1.331	231	1.827	312	2.324
70	0.840	151	1.337	232	1.833	313	2.330
71	0.846	152	1.343	233	1.839	314	2.336
72	0.852	153	1.349	234	1.846	315	2.342
73	0.859	154	1.355	235	1.852	316	2.348
74	0.865	155	1.361	236	1.858	317	2.354
75	0.871	156	1.367	237	1.864	318	2.361
76	0.877	157	1.374	238	1.870	319	2.367
77	0.883	158	1.380	239	1.876	320	2.373
78	0.889	159	1.386	240	1.882	321	2.379
79	0.895	160	1.392	241	1.888	322	2.385
80	0.902	161	1.398	242	1.895	323	2.391
81	0.908	162	1.404	243	1.901	324	2.397
82	0.914	163	1.410	244	1.907	325	2.403
83	0.920	164	1.416	245	1.913	326	2.410
84	0.926	165	1.423	246	1.919	327	2.416
85	0.932	166	1.429	247	1.925	328	2.422
86	0.938	167	1.435	248	1.931	329	2.428
87	0.944	168	1.441	249	1.938	330	2.434
88	0.951	169	1.447	250	1.944	331	2.440
89	0.957	170	1.453	251	1.950	332	2.446
90	0.963	171	1.459	252	1.956	333	2.452
91	0.969	172	1.466	253	1.962	334	2.459
92	0.975	173	1.472	254	1.968	335	2.465
93	0.981	174	1.478	255	1.974	336	2.471
94	0.987	175	1.484	256	1.980	337	2.477

**Table 104 — Discharge Pressure Transducer (PSIG) vs. Voltage (DP-A, DP-B, 48/50A2,A3,A4,A5 Units Only) (cont)**

<b>PRESSURE (PSIG)</b>	<b>VOLTAGE DROP (V)</b>	<b>PRESSURE (PSIG)</b>	<b>VOLTAGE DROP (V)</b>	<b>PRESSURE (PSIG)</b>	<b>VOLTAGE DROP (V)</b>	<b>PRESSURE (PSIG)</b>	<b>VOLTAGE DROP (V)</b>
338	2.483	421	2.992	504	3.501	587	4.010
339	2.489	422	2.998	505	3.507	588	4.016
340	2.495	423	3.004	506	3.513	589	4.022
341	2.502	424	3.010	507	3.519	590	4.028
342	2.508	425	3.016	508	3.525	591	4.034
343	2.514	426	3.023	509	3.531	592	4.040
344	2.520	427	3.029	510	3.538	593	4.046
345	2.526	428	3.035	511	3.544	594	4.052
346	2.532	429	3.041	512	3.550	595	4.059
347	2.538	430	3.047	513	3.556	596	4.065
348	2.544	431	3.053	514	3.562	597	4.071
349	2.551	432	3.059	515	3.568	598	4.077
350	2.557	433	3.066	516	3.574	599	4.083
351	2.563	434	3.072	517	3.580	600	4.089
352	2.569	435	3.078	518	3.587	601	4.095
353	2.575	436	3.084	519	3.593	602	4.102
354	2.581	437	3.090	520	3.599	603	4.108
355	2.587	438	3.096	521	3.605	604	4.114
356	2.593	439	3.102	522	3.611	605	4.120
357	2.600	440	3.108	523	3.617	606	4.126
358	2.606	441	3.115	524	3.623	607	4.132
359	2.612	442	3.121	525	3.629	608	4.138
360	2.618	443	3.127	526	3.636	609	4.144
361	2.624	444	3.133	527	3.642	610	4.151
362	2.630	445	3.139	528	3.648	611	4.157
363	2.636	446	3.145	529	3.654	612	4.163
364	2.643	447	3.151	530	3.660	613	4.169
365	2.649	448	3.157	531	3.666	614	4.175
366	2.655	449	3.164	532	3.672	615	4.181
367	2.661	450	3.170	533	3.679	616	4.187
368	2.667	451	3.176	534	3.685	617	4.193
369	2.673	452	3.182	535	3.691	618	4.200
370	2.679	453	3.188	536	3.697	619	4.206
371	2.685	454	3.194	537	3.703	620	4.212
372	2.692	455	3.200	538	3.709	621	4.218
373	2.698	456	3.206	539	3.715	622	4.224
374	2.704	457	3.213	540	3.721	623	4.230
375	2.710	458	3.219	541	3.728	624	4.236
376	2.716	459	3.225	542	3.734	625	4.243
377	2.722	460	3.231	543	3.740	626	4.249
378	2.728	461	3.237	544	3.746	627	4.255
379	2.734	462	3.243	545	3.752	628	4.261
380	2.741	463	3.249	546	3.758	629	4.267
381	2.747	464	3.256	547	3.764	630	4.273
382	2.753	465	3.262	548	3.770	631	4.279
383	2.759	466	3.268	549	3.777	632	4.285
384	2.765	467	3.274	550	3.783	633	4.292
385	2.771	468	3.280	551	3.789	634	4.298
386	2.777	469	3.286	552	3.795	635	4.304
387	2.784	470	3.292	553	3.801	636	4.310
388	2.790	471	3.298	554	3.807	637	4.316
389	2.796	472	3.305	555	3.813	638	4.322
390	2.802	473	3.311	556	3.820	639	4.328
391	2.808	474	3.317	557	3.826	640	4.334
392	2.814	475	3.323	558	3.832	641	4.341
393	2.820	476	3.329	559	3.838	642	4.347
394	2.826	477	3.335	560	3.844	643	4.353
395	2.833	478	3.341	561	3.850	644	4.359
396	2.839	479	3.347	562	3.856	645	4.365
397	2.845	480	3.354	563	3.862	646	4.371
398	2.851	481	3.360	564	3.869	647	4.377
399	2.857	482	3.366	565	3.875	648	4.384
400	2.863	483	3.372	566	3.881	649	4.390
401	2.869	484	3.378	567	3.887	650	4.396
402	2.875	485	3.384	568	3.893	651	4.402
403	2.882	486	3.390	569	3.899	652	4.408
404	2.888	487	3.397	570	3.905	653	4.414
405	2.894	488	3.403	571	3.911	654	4.420
406	2.900	489	3.409	572	3.918	655	4.426
407	2.906	490	3.415	573	3.924	656	4.433
408	2.912	491	3.421	574	3.930	657	4.439
409	2.918	492	3.427	575	3.936	658	4.445
410	2.925	493	3.433	576	3.942	659	4.451
411	2.931	494	3.439	577	3.948	660	4.457
412	2.937	495	3.446	578	3.954	661	4.463
413	2.943	496	3.452	579	3.961	662	4.469
414	2.949	497	3.458	580	3.967	663	4.475
415	2.955	498	3.464	581	3.973	664	4.482
416	2.961	499	3.470	582	3.979	665	4.488
417	2.967	500	3.476	583	3.985	666	4.494
418	2.974	501	3.482	584	3.991	667	4.500
419	2.980	502	3.488	585	3.997		
420	2.986	503	3.495	586	4.003		

**Forcing Inputs and Outputs** — Many variables may be forced both from the CCN and directly at the local display. This can be useful during diagnostic testing and also during operation, typically as part of an advanced third party control scheme. See Appendices A and B.

NOTE: In the case of a power reset, any force in effect at the time of the power reset will be cleared.

**CONTROL LEVEL FORCING** — If any of the following points are forced with a priority level of 7 (consult CCN literature for a description of priority levels), the software clears the force from the point if it has not been written to or forced again within the timeout periods defined below:

<b>Temperatures</b> → <b>AIR.T</b> → <b>OAT</b>	Outside Air Temperature	30 minutes
<b>Temperatures</b> → <b>AIR.T</b> → <b>RAT</b>	Return Air Temperature	3 minutes
<b>Temperatures</b> → <b>AIR.T</b> → <b>SPT</b>	Space Temperature	3 minutes
<b>Inputs</b> → <b>RSET</b> → <b>SP.RS</b>	Static Pressure Reset	30 minutes
<b>Inputs</b> → <b>REL.H</b> → <b>OA.RH</b>	Outside Air Relative Humidity	30 minutes
<b>Inputs</b> → <b>AIR.Q</b> → <b>OAQ</b>	Outside Air Quality	30 minutes

**Run Status Menu** — The Run Status menu provides the user important information about the unit. The Run Status table can be used to troubleshoot problems and to help determine how and why the unit is operating.

**AUTO VIEW OF RUN STATUS** — The Auto View of Run Status display table provides the most important unit information. The HVAC Mode (**Run Status**→**VIEW**→**HVAC**) informs the user what HVAC mode the unit is currently in. Refer to the Modes section on page 32 for information on HVAC modes. The occupied status, unit temperatures, unit set points, and stage information can also be shown. See Table 105.

**Run Status**→**VIEW**→**HVAC** — Displays the current HVAC Mode(s) by name. HVAC Modes include:

OFF	VENT	HIGH HEAT
STARTING UP	HIGH COOL	FIRE SHUT DOWN
SHUTTING DOWN	LOW COOL	PRESSURIZATION
DISABLED	UNOCC FREE COOL	EVACUATION
SOFTSTOP REQUEST	TEMPERING HICOOL	SMOKE PURGE
REM SW DISABLE	TEMPERING LOCOOL	
COMP STUCK ON	TEMPERING VENT	
TEST	LOW HEAT	

**Run Status**→**VIEW**→**OCC** — This variable displays the current occupancy status of the control.

**Run Status**→**VIEW**→**MAT** — This variable displays the current value for mixed-air temperature. This value is calculated based on return-air and outside-air temperatures and economizer damper position.

**Run Status**→**VIEW**→**EDT** — This variable displays the current evaporator discharge air temperature during Cooling modes. This value is read at the supply air thermistor location (or at cooling coil thermistor array if unit is equipped with hydronic heating coil).

**Run Status**→**VIEW**→**LAT** — This variable displays the current leaving-air temperature during Vent and Hydronic Heating modes. This value is read at the supply air thermistor location.

**Run Status**→**VIEW**→**EC.C.P** — This variable displays the current economizer control point value (a target value for air temperature leaving the evaporator coil location).

**Run Status**→**VIEW**→**ECN.P** — This variable displays the current actual economizer position (in percentage open).

**Run Status**→**VIEW**→**CL.C.P** — This variable displays the current cooling control point (a target value for air temperature leaving the evaporator coil location).

**Run Status**→**VIEW**→**C.CAP** — This variable displays the current amount of unit cooling capacity (in percent of maximum).

**Run Status**→**VIEW**→**HT.C.P** — This variable displays the current heating control point, for use with staged gas control option only (a target value for air temperature leaving the supply duct).

**Run Status**→**VIEW**→**HT.ST** — This variable displays the current number of heating stages active (for staged gas control option only). Compare to following point.

**Run Status**→**VIEW**→**H.MAX** — This variable displays the maximum number of heat stages available for this model.

**ECONOMIZER RUN STATUS** — The Economizer Run Status display table provides information about the economizer and can be used to troubleshoot economizer problems. See Table 106. The current position, commanded position, and whether the economizer is active can be displayed. All the disabling conditions for the economizer and outside air information is also displayed.

**COOLING INFORMATION** — The Cooling Information run status display table provides information on the cooling operation of the unit. See Table 107.

**Current Running Capacity (C.CAP)** — This variable represents the amount of capacity currently running as a percent.

**Current Cool Stage (CUR.S)** — This variable represents the cool stage currently running.

**Requested Cool Stage (REQ.S)** — This variable represents the requested cool stage. Cooling relay time guards in place may prevent the requested cool stage from matching the current cool stage.

**Maximum Cool Stages (MAX.S)** — This variable is the maximum number of cooling stages the control is configured for and capable of controlling.

**Active Demand Limit (DEM.L)** — If demand limit is active, this variable will represent the amount of capacity that the control is currently limited to.

**Capacity Load Factor (SMZ)** — This factor builds up or down over time (–100 to +100) and is used as the means of adding or subtracting a cooling stage during run time. It is a normalized representation of the relationship between “Sum” and “Z”. See the SUMZ Cooling Algorithm section on page 46.

**Next Stage EDT Decrease (ADD.R)** — This variable represents (if adding a stage of cooling) how much the temperature should drop in degrees depending on the **R.PCT** calculation and how much additional capacity is to be added.

$ADD.R = R.PCT * (C.CAP - \text{capacity after adding a cooling stage})$

For example: If **R.PCT** = 0.2 and the control would be adding 20% cooling capacity by taking the next step up, 0.2 times 20 = 4 F **ADD.R**.

**Next Stage EDT Increase (SUB.R)** — This variable represents (if subtracting a stage of cooling) how much the temperature should rise in degrees depending on the **R.PCT** calculation and how much capacity is to be subtracted.

$SUB.R = R.PCT * (C.CAP - \text{capacity after subtracting a cooling stage})$

For Example: If **R.PCT** = 0.2 and the control would be subtracting 30% capacity by taking the next step down, 0.2 times –30 = –6 F **SUB.R**.

**Rise Per Percent Capacity (R.PCT)** — This is a real time calculation that represents the amount of degrees of drop/rise across the evaporator coil versus percent of current running capacity.

$$R.PCT = (MAT - EDT) / C.CAP$$

**Cap Deadband Subtracting (Y.MIN)** — This is a control variable used for Low Temp Override (**L.TMP**) and Slow Change Override (**SLOW**).

$$Y.MIN = -SUB.R * 0.4375$$

**Cap Deadband Adding (Y.PLU)** — This is a control variable used for High Temp Override (**H.TMP**) and Slow Change Override (**SLOW**).

$$Y.PLU = -ADD.R * 0.4375$$

Cap Threshold Subtracting (**Z.MIN**) — This parameter is used in the calculation of **SMZ** and is calculated as follows:

$$Z.MIN = \text{Configuration} \rightarrow \text{COOL} \rightarrow Z.GN * (-10 + (4 * (-SUB.R))) * 0.6$$

Cap Threshold Adding (**Z.PLU**) — This parameter is used in the calculation of **SMZ** and is calculated as follows:

$$Z.PLU = \text{Configuration} \rightarrow \text{COOL} \rightarrow Z.GN * (10 + (4 * (-ADD.R))) * 0.6$$

High Temp Cap Override (**H.TMP**) — If stages of mechanical cooling are on and the error is greater than twice **Y.PLU**, and the rate of change of error is greater than 0.5° F, then a stage of mechanical cooling will be added every 30 seconds. This override is intended to react to situations where the load rapidly increases.

Low Temp Cap Override (**L.TMP**) — If the error is less than twice **Y.MIN**, and the rate of change of error is less than -0.5° F, then a mechanical stage will be removed every 30 seconds. This override is intended to quickly react to situations where the load is rapidly reduced.

Pull Down Cap Override (**PULL**) — If the error from set point is above 4° F, and the rate of change is less than -1° F per minute, then pulldown is in effect, and "SUM" is set to 0. This keeps mechanical cooling stages from being added when the error is very large, but there is no load in the space. Pulldown for units is expected to rarely occur, but is included for the rare situation when it is needed. Most likely pulldown will occur when mechanical cooling first becomes available shortly after the control goes into an occupied mode (after a warm unoccupied mode).

Slow Change Cap Override (**SLOW**) — With a rooftop unit, the design rise at 100% total unit capacity is generally around 30° F. For a unit with 4 stages, each stage represents about 7.5° F of change to EDT. If stages could reliably be cycled at very fast rates, the set point could be maintained very precisely. Since it is not desirable to cycle compressors more than 6 cycles per hour, slow change override takes care of keeping the PID under control when "relatively" close to set point.

MODE TRIP HELPER — The Mode Trip Helper table provides information on the unit modes and when the modes start and stop. See Table 108. This information can be used to help determine why the unit is in the current mode.

CCN/LINKAGE DISPLAY TABLE — The CCN/Linkage display table provides information on unit linkage. See Table 109.

COMPRESSOR RUN HOURS DISPLAY TABLE — The Compressor Run Hours Display Table displays the number of run time hours for each compressor. See Table 110.

COMPRESSOR STARTS DISPLAY TABLE — The Compressor Starts Display Table displays the number of starts for each compressor. See Table 111.

TIME GUARD DISPLAY TABLE — The Time Guard Display Table delay time for each compressor and heat relay. See Table 112.

SOFTWARE VERSION NUMBERS DISPLAY TABLE — The Software Version Numbers Display Table displays the software version numbers of the unit boards and devices. See Table 113.

**Table 105 — Auto View of Run Status Display Table**

ITEM	EXPANSION	RANGE	UNITS	POINT	WRITE STATUS
<b>VIEW</b>	AUTO VIEW OF RUN STATUS				
<b>HVAC</b>	ascii string spelling out the hvac modes			string	
<b>OCC</b>	Occupied ?	YES/NO		OCCUPIED	forcible
<b>MAT</b>	Mixed Air Temperature		dF	MAT	
<b>EDT</b>	Evaporator Discharge Tmp		dF	EDT	
<b>LAT</b>	Leaving Air Temperature		dF	LAT	
<b>EC.C.P</b>	Economizer Control Point		dF	ECONCPNT	
<b>ECN.P</b>	Economizer Act.Curr.Pos.	0-100	%	ECONOPOS	
<b>CL.C.P</b>	Cooling Control Point		dF	COOLCPNT	
<b>C.CAP</b>	Current Running Capacity			CAPTOTAL	
<b>HT.C.P</b>	Heating Control Point		dF	HEATCPNT	
<b>HT.ST</b>	Requested Heat Stage			HT_STAGE	
<b>H.MAX</b>	Maximum Heat Stages			HTMAXSTG	

**Table 106 — Economizer Run Status Display Table**

ITEM	EXPANSION	RANGE	UNITS	POINT	WRITE STATUS
<b>ECON</b>	ECONOMIZER RUN STATUS				
<b>ECN.P</b>	Economizer Act.Curr.Pos.	0-100	%	ECONOPOS	
<b>ECN.C</b>	Economizer Act.Cmd.Pos.	0-100	%	ECONOCMD	forcible
<b>ACTV</b>	Economizer Active ?	YES/NO		ECACTIVE	
<b>DISA</b>	ECON DISABLING CONDITIONS				
<b>UNAV</b>	Econ Act. Unavailable?	YES/NO		ECONUNAV	
<b>R.EC.D</b>	Remote Econ. Disabled?	YES/NO		ECONDISA	
<b>DBC</b>	DBC - OAT Lockout?	YES/NO		DBC_STAT	
<b>DEW</b>	DEW - OA Dewpt.Lockout?	YES/NO		DEW_STAT	
<b>DDBC</b>	DDBD- OAT > RAT Lockout?	YES/NO		DDBCSTAT	
<b>OAEC</b>	OAEC- OA Enth Lockout?	YES/NO		OAECSTAT	
<b>DEC</b>	DEC - Diff.Enth.Lockout?	YES/NO		DEC_STAT	
<b>EDT</b>	EDT Sensor Bad?	YES/NO		EDT_STAT	
<b>OAT</b>	OAT Sensor Bad ?	YES/NO		OAT_STAT	
<b>FORC</b>	Economizer Forced ?	YES/NO		ECONFORC	
<b>SFON</b>	Supply Fan Not On 30s ?	YES/NO		SFONSTAT	
<b>CLOF</b>	Cool Mode Not In Effect?	YES/NO		COOL_OFF	
<b>OAQL</b>	OAQ Lockout in Effect ?	YES/NO		OAQLOCKD	
<b>HELD</b>	Econ Recovery Hold Off?	YES/NO		ECONHELD	
<b>O.AIR</b>	OUTSIDE AIR INFORMATION				
<b>OAT</b>	Outside Air Temperature		dF	OAT	forcible
<b>OA.RH</b>	Outside Air Rel. Humidity		%	OARH	forcible
<b>OA.E</b>	Outside Air Enthalpy			OAE	
<b>OA.D.T</b>	OutsideAir Dewpoint Temp		dF	OADEWTMP	



**Table 107 — Cooling Information Display Table**

ITEM	EXPANSION	RANGE	UNITS	POINT	WRITE STATUS
<b>COOL</b>	COOLING INFORMATION				
<b>C.CAP</b>	Current Running Capacity		%	CAPTOTAL	
<b>CUR.S</b>	Current Cool Stage			COOL_STG	
<b>REQ.S</b>	Requested Cool Stage			CL_STAGE	
<b>MAX.S</b>	Maximum Cool Stages			CLMAXSTG	
<b>DEM.L</b>	Active Demand Limit		%	DEM_LIM	forcible
<b>SUMZ</b>	COOL CAP. STAGE CONTROL				
<b>SMZ</b>	Capacity Load Factor	-100 → +100		SMZ	
<b>ADD.R</b>	Next Stage EDT Decrease		^F	ADDRISE	
<b>SUB.R</b>	Next Stage EDT Increase		^F	SUBRISE	
<b>R.PCT</b>	Rise Per Percent Capacity			RISE_PCT	
<b>Y.MIN</b>	Cap Deadband Subtracting			Y_MINUS	
<b>Y.PLU</b>	Cap Deadband Adding			Y_PLUS	
<b>Z.MIN</b>	Cap Threshold Subtracting			Z_MINUS	
<b>Z.PLU</b>	Cap Threshold Adding			Z_PLUS	
<b>H.TMP</b>	High Temp Cap Override			HI_TEMP	
<b>L.TMP</b>	Low Temp Cap Override			LOW_TEMP	
<b>PULL</b>	Pull Down Cap Override			PULLDOWN	
<b>SLOW</b>	Slow Change Cap Override			SLO_CHNG	

**Table 108 — Mode Trip Helper Display Table**

ITEM	EXPANSION	RANGE	UNITS	POINT	WRITE STATUS
<b>TRIP</b>	MODE TRIP HELPER				
<b>UN.C.S</b>	Unoccup. Cool Mode Start			UCCLSTRT	
<b>UN.C.E</b>	Unoccup. Cool Mode End			UCCL_END	
<b>OC.C.S</b>	Occupied Cool Mode Start			OCCLSTRT	
<b>OC.C.E</b>	Occupied Cool Mode End			OCCL_END	
<b>TEMP</b>	Ctl.Temp RAT,SPT or Zone			CTRLTEMP	
<b>OC.H.E</b>	Occupied Heat Mode End			OCHT_END	
<b>OC.H.S</b>	Occupied Heat Mode Start			OCHTSTRT	
<b>UN.H.E</b>	Unoccup. Heat Mode End			UCHT_END	
<b>UN.H.S</b>	Unoccup. Heat Mode Start			UCHTSTRT	
<b>HVAC</b>	ascii string spelling out the hvac modes			string	

**Table 109 — CCN/Linkage Display Table**

ITEM	EXPANSION	RANGE	UNITS	POINT	WRITE STATUS
<b>LINK</b>	CCN - LINKAGE				
<b>MODE</b>	Linkage Active - CCN	ON/OFF		MODELINK	
<b>L.Z.T</b>	Linkage Zone Control Tmp		dF	LZT	
<b>L.C.SP</b>	Linkage Curr. Cool Setpt		dF	LCSP	
<b>L.H.SP</b>	Linkage Curr. Heat Setpt		dF	LHSP	

**Table 110 — Compressor Run Hours Display Table**

ITEM	EXPANSION	RANGE	UNITS	POINT	WRITE STATUS
<b>HRS</b>	COMPRESSOR RUN HOURS				
<b>HR.A1</b>	Compressor A1 Run Hours	0-999999	HRS	HR_A1	config
<b>HR.A2</b>	Compressor A2 Run Hours	0-999999	HRS	HR_A2	config
<b>HR.B1</b>	Compressor B1 Run Hours	0-999999	HRS	HR_B1	config
<b>HR.B2</b>	Compressor B2 Run Hours	0-999999	HRS	HR_B2	config

**Table 111 — Compressor Starts Display Table**

ITEM	EXPANSION	RANGE	UNITS	POINT	WRITE STATUS
<b>STRT</b>	COMPRESSOR STARTS				
<b>ST.A1</b>	Compressor A1 Starts	0-999999		CY_A1	config
<b>ST.A2</b>	Compressor A2 Starts	0-999999		CY_A2	config
<b>ST.B1</b>	Compressor B1 Starts	0-999999		CY_B1	config
<b>ST.B2</b>	Compressor B2 Starts	0-999999		CY_B2	config

**Table 112 — Time Guard Display Table**

ITEM	EXPANSION	RANGE	UNITS	POINT	WRITE STATUS
TMGD	TIMEGUARDS				
TG.A1	Compressor A1 Timeguard			CMPA1_TG	
TG.A2	Compressor A2 Timeguard			CMPA2_TG	
TG.B1	Compressor B1 Timeguard			CMPB1_TG	
TG.B2	Compressor B2 Timeguard			CMPB2_TG	
TG.H1	Heat Relay 1 Timeguard			HS1_TG	
TG.H2	Heat Relay 2 Timeguard			HS2_TG	
TG.H3	Heat Relay 3 Timeguard			HS3_TG	
TG.H4	Heat Relay 4 Timeguard			HS4_TG	
TG.H5	Heat Relay 5 Timeguard			HS5_TG	
TG.H6	Heat Relay 6 Timeguard			HS6_TG	

**Table 113 — Software Version Numbers Display Table**

ITEM	EXPANSION	RANGE	UNITS	POINT	WRITE STATUS
VERS	SOFTWARE VERSION NUMBERS				
MBB	CESR131343-xx-xx			string	
ECB1	CESR131249-xx-xx			string	
ECB2	CESR131249-xx-xx			string	
SCB	CESR131226-xx-xx			string	
CEM	CESR131174-xx-xx			string	
MARQ	CESR131171-xx-xx			string	
NAVI	CESR130227-xx-xx			string	

**Alarms and Alerts** — There are a variety of different alerts and alarms in the system.

- P — Pre-Alert: Part of the unit is temporarily down. The alarm is not broadcast on the CCN network. The alarm relay is not energized. After an allowable number of retries, if the function does not recover, the pre-alert will be upgraded to an alert or an alarm.
- T — Alert: Part of the unit is down, but the unit is still partially able to provide cooling or heating.
- A — Alarm: The unit is down and is unable to provide cooling or heating.

All alarms are displayed with a code of AXXX where the A is the category of alarm (Pre-Alert, Alert, or Alarm) and XXX is the number.

The response of the control system to various alerts and alarms depends on the seriousness of the particular alert or alarm. In the mildest case, an alert does not affect the operation of the unit in any manner. An alert can also cause a “strike.” A “striking” alert will cause the circuit to shut down for 15 minutes. This feature reduces the likelihood of false alarms causing a properly working system to be shut down incorrectly. If three strikes occur before the circuit has an opportunity to show that it can function properly, the circuit will strike out, causing the shutdown alarm for that particular circuit. Once activated, the shutdown alarm can only be cleared via an alarm reset.

Circuits with strikes are given an opportunity to reset their strike counter to zero. As discussed above, a strike typically causes the circuit to shut down. Fifteen minutes later, that circuit will once again be allowed to run. If the circuit is able to run for 1 minute, its replacement circuit will be allowed to shut down (if not required to run to satisfy requested stages). However, the “troubled” circuit must run continuously for 5 minutes with no detectable problems before the strike counter is reset to zero.

All the alarms and alerts are summarized in Table 114.

**DIAGNOSTIC ALARM CODES AND POSSIBLE CAUSES**

T051, P051 (Circuit A, Compressor 1 Failure)

T052, P052 (Circuit A, Compressor 2 Failure)

T055, P055 (Circuit B, Compressor 1 Failure)

T056, P056 (Circuit B, Compressor 2 Failure) — Alert codes 051, 052, 055, and 056 are for compressors A1, A2, B1, and B2 respectively. These alerts occur when the current sensor (CS) does not detect compressor current during compressor

operation. When this occurs, the control turns off the compressor and logs a strike for the respective circuit. These alerts reset automatically.

If the current sensor board reads OFF while the compressor relay has been commanded ON for a period of 4 continuous seconds, an alert is generated.

Any time this alert occurs, a strike will be called out on the affected compressor. If three successive strikes occur the compressor will be locked out requiring a manual reset or power reset of the circuit board. The clearing of strikes during compressor operation is a combination of 3 complete cycles or 15 continuous minutes of run time operation. So, if there are one or two strikes on the compressor and three short cycles (ON-OFF, ON-OFF, ON-OFF) less than 15 minutes each occur, the strikes will be reset to zero for the affected compressor. Also, if the compressor turns on and runs for 15 minutes straight with no compressor failure, the compressor’s strikes are cleared as well.

NOTE: Until the compressor is locked out, for the first two strikes, the alert will not be broadcast to the network, nor will the alarm relay be closed.

The possible causes are:

- High-pressure switch (HPS) open. The HPS is wired in series with compressor relays on the MBB. If the high-pressure switch opens during compressor operation, the compressor stops, and the CS no longer detects current, causing the control to activate this alert.

For 48/50AJ,AK,AW,AY units:

- Compressor internal overload protection is open. The internal overloads are used on the Scroll Tech compressors (black) and smaller Maneurop compressors used on the size 020, 025, 027, 030, 035 units and 040 A1, A2 compressors.
- Internal compressor temperature sensor trip. The large Maneurop compressors (blue) used on the size 040 (B1, B2), 050, and 060 units have an internal temperature sensor.
- Circuit breaker trip. The compressors are protected from short circuit by a breaker in the control box. On the size 020-035 and 040 A1, A2 units there is one breaker per two compressors and on the size 040 (B1, B2), 050, and 060 compressors there is one breaker per compressor because there are not internal overloads.
- Wiring error. A wiring error might not allow the compressor to start.

**Table 114 — Alert and Alarm Codes**

ALARM OR ALERT NUMBER	DESCRIPTION	ACTION TAKEN BY CONTROL	RESET METHOD	PROBABLE CAUSE
A051	Circuit A, Compressor 1 Stuck On Failure	Turn off all compressors	Manual	Welded contact
P051	Circuit A, Compressor 1 Failure	Add strike to compressor	Automatic (max 3)	High pressure switch, compressor current, wiring error
T051	Circuit A, Compressor 1 Failure	Compressor locked off	Manual	Exceeded 3 strike limit
A052	Circuit A, Compressor 2 Stuck On Failure	Turn off all compressors	Manual	Welded contact
P052	Circuit A, Compressor 2 Failure	Add strike to compressor	Automatic (max 3)	High pressure switch, compressor current, wiring error
T052	Circuit A, Compressor 2 Failure	Compressor locked off	Manual	Exceeded 3 strike limit
A055	Circuit B, Compressor 1 Stuck On Failure	Turn off all compressors	Manual	Welded contact
P055	Circuit B, Compressor 1 Failure	Add strike to compressor	Automatic (max 3)	High pressure switch, compressor current, wiring error
T055	Circuit B, Compressor 1 Failure	Compressor locked off	Manual	Exceeded 3 strike limit
A056	Circuit B, Compressor 2 Stuck On Failure	Turn off all compressors	Manual	Welded contact
P056	Circuit B, Compressor 2 Failure	Add strike to compressor	Automatic (max 3)	High pressure switch, compressor current, wiring error
T056	Circuit B, Compressor 2 Failure	Compressor locked off	Manual	Exceeded 3 strike limit
T064	Circuit A Saturated Condensing Thermistor Failure (48/50AJ,AK,AW,AY units only)	Use OAT for head pressure control	Automatic	Faulty thermistor or wiring error
T065	Circuit B Saturated Condensing Thermistor Failure (48/50AJ,AK,AW,AY units only)	Use OAT for head pressure control	Automatic	Faulty thermistor or wiring error
T072	Evaporator Discharge Reset Sensor Failure	Unit shutdown	Automatic	Faulty remote input on CEM board
T073	Outside Air Temperature Thermistor Failure	Stop use of economizer	Automatic	Faulty thermistor or wiring error
T074	Space Temperature Thermistor Failure	Unit shutdown	Automatic	Faulty thermistor or wiring error
T075	Return Air Thermistor Failure	Continue to run unit	Automatic	Faulty thermistor or wiring error
T076	Outside Air Relative Humidity Sensor Failure	Use OAT changeover control	Automatic	Faulty sensor or wiring error
T078	Return Air Relative Humidity Sensor Failure	Use differential dry bulb changeover	Automatic	Faulty sensor or wiring error
T082	Space Temperature Offset Sensor Failure	Use Space temperature without offset	Automatic	Faulty sensor or wiring error
T090	Circuit A Discharge Pressure Transducer Failure	Stop circuit	Automatic	Faulty sensor, wiring error
T091	Circuit B Discharge Pressure Transducer Failure	Stop circuit	Automatic	Faulty sensor, wiring error
T092	Circuit A Suction Pressure Transducer Failure	Stop circuit	Automatic	Faulty sensor, wiring error
T093	Circuit B Suction Pressure Transducer Failure	Stop circuit	Automatic	Faulty sensor, wiring error
T110	Circuit A Loss of Charge	Stop circuit	Manual	Low refrigerant charge
T111	Circuit B Loss of Charge	Stop circuit	Manual	Low refrigerant charge
A120	Circuit A Low Saturated Suction Temperature Alarm.	Stop circuit	Manual	Low refrigerant charge, low airflow, dirty coil, broken fan belt, TXV problem
P120	Circuit A Low Saturated Suction Temp-Comp A2 Shutdown	Compressor A2 shutdown	Automatic	Low refrigerant charge, low airflow, dirty coil, broken fan belt, TXV problem
T120	Circuit A Low Saturated Suction Temperature Alert.	Stop circuit	Automatic	Low refrigerant charge, low airflow, dirty coil, broken fan belt, TXV problem
A121	Circuit B Low Saturated Suction Temperature Alarm.	Stop circuit	Manual	Low refrigerant charge, low airflow, dirty coil, broken fan belt, TXV problem
P121	Circuit B Low Saturated Suction Temp-Comp B2 Shutdown	Compressor B2 shutdown	Automatic	Low refrigerant charge, low airflow, dirty coil, broken fan belt, TXV problem
T121	Circuit B Low Saturated Suction Temperature Alert.	Stop circuit	Automatic	Low refrigerant charge, low airflow, dirty coil, broken fan belt, TXV problem
T122	Circuit A High Saturated Suction Temperature	Stop circuit	Manual	TXV problem, high load
T123	Circuit B High Saturated Suction Temperature	Stop circuit	Manual	TXV problem, high load
P126	Circuit A High Head Pressure, Comp Shutdown	Circuit staged down	Automatic	Dirty condenser, condenser fan failure, system overcharged
T126	Circuit A High Head Pressure Alert	Stop circuit	Automatic	Dirty condenser, condenser fan failure, system overcharged
A126	Circuit A High Head Pressure Alarm	Stop circuit	Manual	Dirty condenser, condenser fan failure, system overcharged
P127	Circuit B High Head Pressure Comp Shutdown	Circuit staged down	Automatic	Dirty condenser, condenser fan failure, system overcharged.
T127	Circuit B High Head Pressure Alert	Stop circuit	Automatic	Dirty condenser, condenser fan failure, system overcharged
A127	Circuit B High Head Pressure Alarm	Stop circuit	Manual	Dirty condenser, condenser fan failure, system overcharged
A140	Reverse Rotation Detected	Stop unit	Manual	Incorrect compressor wiring
A150	Unit is in Emergency Stop	Stop unit	Manual	External shutdown command
T153	Real Time Clock Hardware Failure	Stop unit	Manual	Control Board failure, check lights
A154	Serial EEPROM Hardware Failure	Stop unit	Manual	Control Board failure, check lights
T155	Serial EEPROM Storage Failure Error	Stop unit	Manual	Control Board failure, check lights
A156	Critical Serial EEPROM Storage Failure Error	Stop unit	Manual	Control Board failure, check lights
A157	A/D Hardware Failure	Stop unit	Manual	Control Board failure, check lights
A171	Staged Gas Control Board Comm Failure	Stop gas heat	Automatic	Control Board failure, check lights
A172	Controls Expansion Module Comm Failure	Stop options on CEM	Automatic	Control Board failure, check lights
A173	ECB1 Board Communication Failure	Stop economizer & power exh	Automatic	Control Board failure, check lights
A174	ECB2 Board Communication Failure	Stop unit	Automatic	Control Board failure, check lights
T177	4-20 MA Demand Limit Failure	Stop demand limiting	Automatic	Input failure, wiring error
T178	4-20 MA Static Pressure Reset/VFD Fail	Stop static pressure reset/VFD	Automatic	Input Failure, wiring error
A200	Linkage Timeout Error - Communication Failure	Stop unit	Manual	Wiring errors, board failures
T210	Building Pressure Transducer Failure	Close economizer, stop exhaust	Automatic	Sensor failure, wiring error
T211	Static Pressure Transducer Failure	Stop unit	Automatic	Sensor failure, wiring error

**Table 114 — Alert and Alarm Codes (cont)**

ALARM OR ALERT NUMBER	DESCRIPTION	ACTION TAKEN BY CONTROL	RESET METHOD	PROBABLE CAUSE
T220	Indoor Air Quality Sensor Failure	Stop IAQ control	Automatic	Sensor failure, wiring error
T221	Outdoor Air Quality Sensor Failure	Use a default value for IAQ	Automatic	Sensor failure, wiring error
T229	Economizer Minimum Position Override Input Failure	Use software configured minimum	Automatic	Input failure, wiring error
T300	Space Temperature Below Limit	Stop cooling, but continue to heat	Automatic	Outdoor dampers stuck, no load
T301	Space Temperature Above Limit	Stop heating, but continue to cool	Automatic	High load, dampers open
T302	Supply Temperature Below Limit	Continue to run unit	Automatic	Dampers open, check configuration setpoint
T303	Supply Temperature Above Limit	Continue to run unit	Automatic	Dampers open, check configuration setpoint
T304	Return Temperature Below Limit	Continue to run unit	Automatic	Dampers open, check configuration setpoint
T305	Return Temperature Above Limit	Continue to run unit	Automatic	Dampers open, check configuration setpoint
T308	Return Air Relative Humidity Below Limit	Alert	Automatic	Configuration error, or sensor error
T309	Return Air Relative Humidity Above Limit	Continue to run unit	Automatic	Dampers open, check configuration setpoint
T310	Supply Duct Static Pressure Below Limit	Continue to run unit	Automatic	VFD problem, broken fan belt
T311	Supply Duct Static Pressure Above Limit	Continue to run unit	Automatic	VFD problem, broken fan belt
T312	Building Static Pressure Below Limit	Continue to run unit	Automatic	Exhaust issues, check setpoint
T313	Building Static Pressure Above Limit	Continue to run unit	Automatic	Exhaust issues, check setpoint
T314	IAQ Above Limit	Continue to run unit	Automatic	Damper or IAQ control issues
A404	Fire Shut Down Emergency Mode (fire-smoke)	Unit Shutdown	Automatic	Smoke detector switch or external switch
A405	Evacuation Emergency Mode	Run power exhaust	Automatic	Special fire mode control
A406	Pressurization Emergency Mode	Run supply fan	Automatic	Special fire mode control
A407	Smoke Purge Emergency Mode	Run supply and exhaust fans	Automatic	Special fire mode control
T408	Dirty Air Filter	Continue to run unit	Automatic	Dirty filter, switch setting
A409	Supply Fan Status Failure	Stop unit	Automatic	Fan drive failure
T409	Supply Fan Status Failure	Continue to run unit	Automatic	Fan drive failure, or sensor failure
T414	Loss of Communication with the Belimo Actuator	Close economizer	Automatic	Calibrate economizer, economizer failure, wiring
T414	Belimo Actuator Direction Error	Close economizer	Automatic	Motor direction switch wrong, wiring
T414	Belimo Actuator Failure	Attempt to close economizer	Automatic	Motor failure
T414	Belimo Actuator Jammed	Close economizer	Automatic	Obstruction in damper
T414	Belimo Actuator Range Error	Close economizer	Automatic	Calibrate economizer
T420	R-W1 Jumper Must Be Installed to Run Heat in Service Test	No heat	Automatic	Add red wire jumpers
T421	Thermostat Y2 Input ON without Y1 ON	Assume Y2 is Y1	Automatic	Thermostat wiring error
T422	Thermostat W2 Input ON without W1 ON	Assume W2 is W1	Automatic	Thermostat wiring error
T423	Thermostat Y and W Inputs ON	Alert	Automatic	Thermostat issues
T424	Thermostat G Input OFF on a Call for Cooling	Turn fan on	Automatic	Thermostat or wiring issues
T500	Current Sensor Board Failure - A1	Stop compressor A1	Automatic	Faulty board or wiring
T501	Current Sensor Board Failure - A2	Stop compressor A2	Automatic	Faulty board or wiring
T502	Current Sensor Board Failure - B1	Stop compressor B1	Automatic	Faulty board or wiring
T503	Current Sensor Board Failure - B2	Stop compressor B2	Automatic	Faulty board or wiring
A700	Supply Air Temperature Sensor Failure	Stop staged gas heat	Automatic	Faulty sensor or wiring error
T701	Staged Gas Thermistor 1 Failure	Stop staged gas heat	Automatic	Faulty sensor or wiring error
T702	Staged Gas Thermistor 2 Failure	Stop staged gas heat	Automatic	Faulty sensor or wiring error
T703	Staged Gas Thermistor 3 Failure	Stop staged gas heat	Automatic	Faulty sensor or wiring error
A704	Staged Gas Leaving Air Temp Sum Total Failure	Stop staged gas heat	Automatic	Faulty sensor or wiring error
T705	Limit Switch Thermistor Failure	Stop staged gas heat	Automatic	Faulty switch or wiring

**LEGEND**

- |  |   |
|--|---|
| <b>Axxx</b> — Alarm                    | <b>Pxxx</b> — Pre-Alert                   |
| <b>CEM</b> — Controls Expansion module | <b>Txxx</b> — Alert                       |
| <b>IAQ</b> — Indoor Air Quality        | <b>TXV</b> — Thermostatic Expansion Valve |
| <b>OAT</b> — Outdoor Air Temperature   | <b>VFD</b> — Variable Frequency Drive     |

For 48/50A2,A3,A4,A5 units:

- Compressor internal overload protector is open. Internal overload protectors are used in the Copeland compressors in all units except size 60 ton units with voltages of 208/230-v, 380-v, and 575-v.
- Compressor external overload protector (Kriwan module) has activated. The Copeland compressors in size 60 ton units with voltages of 208/230-v, 380-v, and 575-v use external overload protector modules that are mounted in the compressor wiring junction box. Temperature sensors embedded in the compressor motor windings are the inputs to the module. The module is powered with 120 vac from the units main control box. The module output is a normally closed contact that is wired in series with the compressor

contactor coil. In a compressor motor overload condition, the contact opens de-energizing the compressor contactor.

- Circuit breaker trip. The compressors are protected from short circuit by a breaker in the control box. On the 020-050 size units there is one breaker per two compressors and on the 060 size units there is one breaker per compressor.
- Wiring Error. A wiring error might not allow the compressor to start.

To check out alerts 051, 052, 055 and 056:

- Turn on the compressor in question using Service Test mode. If the compressor does not start, then most likely the problem is one of the following: HPS open, open internal protection, circuit breaker trip, incorrect safety wiring, or incorrect compressor wiring.

2. If the compressor does start verify it is rotating in the correct direction.

**IMPORTANT:** Prolonged operation in the wrong direction can damage the compressor. Correct rotation can be verified by a gage set and looking for a differential pressure rise on start-up.

**IMPORTANT:** If the compressor starts, verify that the indoor and outdoor fans are operating properly.

**IMPORTANT:** If the CS is always detecting current, then verify that the compressor is on. If the compressor is on, check the contactor and the relay on the MBB. If the compressor is off and there is no current, verify CS wiring and replace if necessary.

**IMPORTANT:** Return to Normal mode and observe compressor operation to verify that compressor current sensor is working and condenser fans are energized after compressor starts.

A051 (Circuit A, Compressor 1 Stuck On Failure)

A052 (Circuit A, Compressor 2 Stuck On Failure)

A055 (Circuit B, Compressor 1 Stuck On Failure)

A056 (Circuit B, Compressor 2 Stuck On Failure) — Alarm codes 051, 052, 055, and 056 are for compressors A1, A2, B1, B2 respectively. These alarms occur when the current sensor (CS) detects current when the compressor should be off. When this occurs, the control turns off the compressor and logs a strike for the respective circuit. Use the scrolling marquee to reset the alarm.

If the current sensor board reads ON while the compressor relay has been commanded OFF for a period of 4 continuous seconds, an alarm is generated. These alarms are only monitored for a period of 10 seconds after the compressor relay has been commanded OFF. This is done to facilitate a service technician forcing a relay to test a compressor.

In addition, if a compressor stuck failure occurs and the current sensor board reports the compressor and the request off, certain diagnostics will take place.

1. If any of the 4 compressors are diagnosed as stuck on and the current sensor board is on and the request is off, the control will request the supply fan which will automatically start building airflow control. Condenser fans will also be commanded on to maintain normal head pressure.
2. Heating will be disabled while any one of the compressors has this problem.

The possible causes are:

- welded contactor
- frozen compressor relay on MBB

To check out alarms 051, 052, 055, and 056:

1. Place the unit in Service Test mode. All compressors should be off.
2. Verify that there is not 24 v at the contactor coil. If there is 24 v at the contactor, check relay on MBB and wiring.
3. Check for welded contactor.
4. Verify CS wiring.
5. Return to Normal mode and observe compressor operation to verify that compressor current sensor is working and condenser fans are energized after compressor starts.

T064 (Circuit A Saturated Condensing Thermistor Failure)

T065 (Circuit B Saturated Condensing Thermistor Failure) — Alert codes 064 and 065 are for circuits A and B, respectively. This alert code is for 48/50AJ,AK,AW,AY units only. These alerts occur when the saturated condensing temperatures (*Temperatures*→*REF.T*→*SCT.A* and *SCT.B*) are outside the range

–40 to 240 F (–40 to 116 C). When this occurs, the control uses the outdoor temperature (*OAT*) to control the outdoor fans. The control will default to control based on the OAT sensor and will turn on OFC.B when the ambient is above 65 F and off when the ambient is below 50 F.

If the SCT and OAT sensors have all failed then the control should turn on OFC.B when compressors are on.

The cause of the alert is usually a faulty thermistor, a shorted or open thermistor caused by a wiring error, or a loose connection.

T072 (Evaporator Discharge Reset Sensor Failure) — If the unit is configured to use the remote EDT 4 to 20 mA reset input (*Configuration*→*EDT.R*→*RES.S*) and the sensor reading is less than 2 mA then the alert will occur. When this occurs the control will default to the internal set points. The sensor is connected to the optional CEM module. For this sensor to be used, the EDT 4 to 20 mA reset input (*Configuration*→*EDT.R*→*RES.S*) must be set to “enabled.”

T073 (Outside Air Temperature Thermistor Failure) — This alert occurs when the outside air temperature sensor (*Temperatures*→*AIR.T*→*OAT*) is outside the range –40 to 240 F (–40 to 116 C). Failure of this thermistor (*Temperatures*→*AIR.T*→*OAT*) will disable any elements of the control which requires its use. Economizer control beyond the vent position and the calculation of mixed-air temperature for the sumZ algorithm will not be possible. This alert resets automatically. The cause of the alert is usually a faulty thermistor, a shorted or open thermistor caused by a wiring error, or a loose connection.

T074 (Space Temperature Thermistor Failure) — This alert occurs when the space temperature sensor (*Temperatures*→*AIR.T*→*SPT*) is outside the range –40 to 240 F (–40 to 116 C). This alert will only occur if the unit is configured to use a space temperature sensor. Configuration is done through the Unit Control Type (*Configuration*→*UNIT*→*C.TYP*) configuration. Failure of this thermistor (*Temperatures*→*AIR.T*→*SPT*) will disable any elements of the control which requires its use. If the unit is configured for SPT 2 stage or SPT multi-stage operation and the sensor fails, no cooling or heating mode may be chosen. This alert resets automatically. The cause of the alert is usually a faulty thermistor in the T55, T56, or T58 device, a shorted or open thermistor caused by a wiring error, or a loose connection.

T075 (Return Air Thermistor Failure) — This alert occurs when the return air temperature sensor (*Temperatures*→*AIR.T*→*RAT*) is outside the range –40 to 240 F (–40 to 116 C). The RAT is standard on all units and is located in the return section near the auxiliary control box. This alert resets automatically. The cause of the alert is usually a faulty thermistor, a shorted or open thermistor caused by a wiring error, or a loose connection.

Failure of this thermistor (*Temperatures*→*AIR.T*→*RAT*) will disable any elements of the control which requires its use. Elements of failure include:

- the calculation of mixed air temperature for sumZ control
- the selection of a mode for VAV units
- economizer differential enthalpy or dry bulb control
- return air temperature supply air reset

T076 (Outside Air Relative Humidity Sensor Failure) — This alert occurs when the outside air humidity sensor (*Inputs*→*REL.H*→*OA.RH*) has a reading less than 2 mA. Failure of this sensor will disable any elements of the control which requires its use including economizer outdoor and differential enthalpy control. The OA.RH sensor is located in the economizer hood and is used for control of the economizer. The sensor is a loop powered 4 to 20 mA sensor. This alert resets automatically. The cause of the alert is usually a faulty sensor, a shorted or open sensor caused by a wiring error, or a loose connection. The unit must be configured to use the sensor through the

Outside Air RH Sensor (*Configuration*→*ECON*→*ORH.S*) setting.

**T078 (Return Air Relative Humidity Sensor Failure)** — This alert occurs when the return air humidity sensor (*Inputs*→*REL.H*→*RA.RH*) has a reading less than 2 mA. Failure of this sensor (*Inputs*→*REL.H*→*RA.RH*) will disable any elements of the control which requires its use including economizer differential enthalpy control.

The RA.RH sensor is located in the return air section near the auxiliary control box. The sensor is a loop powered 4 to 20 mA sensor. This alert resets automatically. The cause of the alert is usually a faulty sensor, a shorted or open sensor caused by a wiring error, or a loose connection. The unit must be configured to use the sensor through the Outside Air RH Sensor (*Configuration*→*UNIT*→*SENS*→*RRH.S*) setting.

**T082 (Space Temperature Offset Sensor Failure)** — If the unit is configured to use a space temperature sensor and is using a T56 sensor with an offset potentiometer, then the alert will occur if the potentiometer is outside the allowable range. The control will default to the software applicable set point because there is no offset available that may be applied to space temperature. The alert will automatically clear. The unit must be configured for one of the SPT control options through the Unit Control Type (*Configuration*→*UNIT*→*C.TYP*) configuration.

**T090 (Circuit A Discharge Pressure Transducer Failure)**

**T091 (Circuit B Discharge Pressure Transducer Failure)** — Alert codes 090, and 091 are for circuits A and B respectively. These alerts occur when the unit is configured for pressure transducers (*Configuration*→*UNIT*→*DP.XR*) and the pressure is outside the range 0.0 to 667.0 psig. A circuit cannot run when this alert is active. Use the scrolling marquee to reset the alert. The cause of the alert is usually a faulty transducer, faulty 5v power supply, or a loose connection. Although the software supports this option, it is not possible at the time of the writing of this specification to order the optional discharge pressure transducers.

**T092 (Circuit A Suction Pressure Transducer Failure)**

**T093 (Circuit B Suction Pressure Transducer Failure)** — Alert codes 092, and 093 are for circuits A and B respectively. These alerts occur when the pressure is outside the following ranges: 0.5 to 134.5 psig when *SP.XR*=0, 0.0 to 200.0 psig when *SP.XR*=1, and 0.0 to 420.0 psig on all 48/50A2,A3,A4,A5 units. A circuit cannot run when this alert is active. Use the scrolling marquee to reset the alert. The cause of the alert is usually a faulty transducer, faulty 5 v power supply, or a loose connection.

**T110 (Circuit A Loss of Charge)**

**T111 (Circuit B Loss of Charge)** — Alert codes 110, and 111 are for circuits A, and B respectively. These alerts occur when the compressor is OFF and the suction pressure is less than 5 psig for 48/50AJ,AK,AW,AY units or 18 psig for 48/50A2, A3,A4,A5 units and the OAT is above -5 F for 1 continuous minute. The alert will automatically clear when the suction pressure transducer reading is valid and greater than 15 psig for 48/50AJ,AK,AW,AY units or 54 psig for 48/50A2,A3,A4,A5 units. The cause of the alert is usually low refrigerant pressure or a faulty suction pressure transducer.

**P120 (Circuit A Low Saturated Suction Temperature — Compressor A2 Shutdown)**

**T120 (Circuit A Low Saturated Suction Temperature Alert)**

**A120 (Circuit A Low Saturated Suction Temperature Alarm)**

**P121 (Circuit B Low Saturated Suction Temperature — Compressor B2 Shutdown)**

**T121 (Circuit B Low Saturated Suction Temperature Alert)**

**A121 (Circuit B Low Saturated Suction Temperature Alarm)** — This alert/alarm is used to keep the evaporator coils from freezing and the saturated suction temperature above the low limit for the compressors.

There will be a start-up delay if the outside-air temperature is too low. When the outdoor ambient is below 60 F, during initial start-up, saturated suction temperature will be ignored for a period of 5 minutes. When *Temperatures*→*REF.T*→*SSTA* or *Temperatures*→*REF.T*→*SSTB* is less than 20 F for 4 minutes, less than 10 F for 2 minutes, less than 0° F for 1 minute or less than -20 F for 20 seconds continuously, the second compressor of the affected circuit, if it exists, will be shut down with a local alert (P120, P121) and a 10-minute timeguard will be added to the compressor. If saturated suction temperature continues to be less than 20 F for 4 minutes, less than 10 F for 2 minutes, less than 0° F for 1 minute or less than -20 F for 20 seconds continuously then compressor no. 1 will be shut down and then an alert or alarm will be issued.

This failure follows a 3 strike methodology whereby the first two times a circuit goes down entirely, an alert will be generated which keeps the circuit off for 15 minutes before allowing the circuit to try again. The third time this happens, an alarm will be generated which will necessitate a manual reset to get the circuit back running. It is important to note that a “strike” is called out only if all compressors in the circuit are off at the time of alert/alarm.

To prevent nuisance alerts, P120 and P121 show up in the alarm history and locally at the display but are not broadcast to the network. To recover from these alerts, a 10-minute holdoff timer must elapse and the saturated suction temperature must rise above 29.32 F. If recovery occurs, staging will be allowed on the circuit again. Again, a “strike” is tied to the circuit going off entirely, not reducing capacity and recovering. Therefore it is possible that multiple P120 or P121 alerts may be stored in alarm history but not broadcast.

If there are 1 or 2 strikes on the circuit and the circuit recovers for a period of time, it is possible to clear out the strikes thereby resetting the strike counter automatically. The control must have saturated suction temperature greater than or equal to 34 F for 60 minutes in order to reset the strike counters.

**T122 (Circuit A High Saturated Suction Temperature)**

**T123 (Circuit B High Saturated Suction Temperature)** — Alert codes 122 and 123 occur when compressors in a circuit have been running for at least 5 to 30 minutes (*Configuration*→*COOL*→*H.SST*). On 48/50AJ,AK,AW,AY units, this alert code occurs if the circuit saturated suction temperature is greater than 60 F. On 48/50A2,A3,A4,A5 units, this alert code occurs if the circuit saturated suction temperature is greater than 65 F when one compressor is running or 60 F when two compressors are running. For all units, the high saturated suction alert is generated and the circuit is shut down. Alert code 122 is for circuit A and 123 for circuit B.

**LRTA High Saturated Condensing Temperature Alert/Alarm**

**P126 (Circuit A High Head Pressure, Comp Shutdown)**

**T126 (Circuit A High Head Pressure Alert)**

**A126 (Circuit A High Head Pressure Alarm)**

**P127 (Circuit B High Head Pressure, Comp Shutdown)**

**T127 (Circuit B High Head Pressure Alert)**

**A127 (Circuit B High Head Pressure Alarm)** — This alert/ alarm is used to keep the saturated condensing temperature below maximum recommended compressor operating pressure. This alert/ alarm attempts to prevent the saturated condensing temperature from reaching the high pressure switch trip point by reducing the number of compressors operating on a circuit.

When the saturated condensing temperature on a circuit is greater than 145 F (140 F on R-22 units), no compressors will be added to the circuit.

When temperatures *REF.T*, *SCTA*, or temperatures *REF.T*, *SCTB* rise above 150 F (145 F on R-22 units), a compressor of the affected circuit will be immediately shut down with pre-alert (P126,P127) and a 10-minute timeguard will be added to the compressor. If the saturated condensing temperature

remains above 150 F (145 F on R-22 units) for 10 more seconds, another compressor of the affected circuit, if it exists, will be shut down with pre-alert (P126, P127) and a 10-minute timeguard will be added to the compressor. This sequence will continue until the last compressor on the circuit is shut down, at which time the circuit will be shut down with alert (T126, T127).

This failure follows a three strike methodology. When the circuit is shut down entirely, an alert (T126, T127) is generated and a strike is logged on the circuit. On the third strike, alarm (A126, A127) will be generated which will necessitate a manual reset to get the circuit back running. It is important to note that a strike is called out only if all compressors in the circuit are off at the time of the alert.

To prevent nuisance alerts, P126 and P127 show up in the alarm history and locally at the display, but are never broadcast to the network. To recover from these alerts, both a 10-minute hold off timer and saturated condensing temperature returning under the compressor envelope must occur. If recovery occurs, staging will be allowed on the circuit once again. Again, a strike is tied to the circuit going off entirely, not reducing capacity and recovering. Therefore, it is possible that multiple P126 and P127 alerts may be stored in alarm history but not broadcast.

**A140 (Reverse Rotation Detected)** — A test is made once, on power up, for suction pressure change on the first activated circuit. The unit control determines failure is as follows:

The suction pressure of both circuits is sampled 5 seconds before the compressor is brought on, right when the compressor is brought on and 5 seconds afterwards. The rate of suction pressure change from 5 seconds before the compressor is brought on to when the compressor is brought on is calculated. Then the rate of suction pressure change from when the compressor is brought on to 5 seconds afterwards is calculated.

With the above information, the test for reverse rotation is made. If the suction pressure change 5 seconds after compression is greater than the suction pressure change 5 seconds before compression – 1.25, then there is a reverse rotation error.

This alarm will disable mechanical cooling and will require a manual reset. This alarm may be disabled once the reverse rotation check has been verified by setting **Configuration** → **COOL** → **REVR** = Yes.

**A150 (Unit is in Emergency Stop)** — If the fire safety input condition occurs to indicate a fire or smoke condition, then Alarm code 150 will occur and the unit will be immediately stopped. Through separate inputs the unit can be put into purge, evacuation, and pressurization. This requires a manual reset.

If the CCN point name “EMSTOP” in the System table is set to emergency stop, the unit will shut down immediately and broadcast an alarm back to the CCN indicating that the unit is down. This alarm will clear when the variable is set back to “enable.”

**T153 (Real Time Clock Hardware Failure)** — A problem has been detected with the real timeclock on the MBB. Try resetting the power and check the indicator lights. If the alert continues, the board should be replaced.

**A154 (Serial EEPROM Hardware Failure)** — A problem has been detected with the EEPROM on the MBB. Try resetting the power and check the indicator lights. If the alarm continues, the board should be replaced.

**T155 (Serial EEPROM Storage Failure Error)** — A problem has been detected with the EEPROM storage on the MBB. Try resetting the power and check the indicator lights. If the alert continues, the board should be replaced.

**A156 (Critical Serial EEPROM Storage Failure Error)** — A problem has been detected with the EEPROM storage on the MBB. Try resetting the power and check the indicator lights. If the alarm continues, the board should be replaced.

**A157 (A/D Hardware Failure)** — A problem has been detected with A/D conversion on the boards. Try resetting the power and check the indicator lights. If the alarm continues, the board should be replaced.

**A171 (Staged Gas Control Board Comm Failure)** — This alarm indicates that there are communications problems with the staged gas heat control board, which is located in the gas section on units equipped with staged gas heat. If this alarm occurs, the staged gas heat will be disabled. The alarm will automatically reset.

**A172 (Controls Expansion Module Comm Failure)** — This alarm indicates that there are communications problems with the controls expansion board. All functions performed by the CEM will stop, which can include demand limit, reset, fire control modes, and the fan status switch. The alarm will automatically reset.

**A173 (ECB1 Board Communication Failure)** — This alarm indicates that there are communications problems with the economizer control board. This will result in the economizer and the power exhaust not working and the dampers to be fully closed. The exhaust fans will stop. The alarm will automatically reset.

**A174 (ECB2 Board Communication Failure)** — This alarm indicates that there are communications problems with the ECB2 which controls the VAV unit indoor fan inverter speed and hot gas bypass on CV and VAV units. Because the control of the fan is critical to unit operation, the unit will be stopped. The alarm will automatically reset.

**T177 (4-20 mA Demand Limit Failure)** — This alert indicates a problem with the optional remote 4 to 20 mA demand limit signal (**Inputs** → **4-20** → **DL.M**) that is connected to the CEM module (if the signal reads less than 2 mA). If this occurs, then demand limiting will be disabled. The unit must be configured for 4 to 20 mA Demand Limiting using the Demand Limit Select (**Configuration** → **DMD.L** → **DM.L.S**).

**T178 (4-20 mA Static Pressure Reset/VFD Failure)** — If this transducer fails (if the signal reads less than 2 mA on the input of the CEM module), and the unit is configured to perform static pressure reset or remote control of the supply fan VFD with this transducer, no static pressure reset or VFD control will be performed and an alert will be generated. Recovery is automatic. Reason for error is either a faulty sensor, wiring error, or damaged input on the CEM control board.

**A200 (Linkage Timeout Error — Comm Failure)** — If linkage is established via the CCN with ComfortID™ terminals, a 5-minute timeout on loss of communication will be monitored. If 5 minutes expires since the last communication from a VAV Linkage Master, the unit will remove the link and flag the alert. When the rooftop loses its link, the temperature and set points are derived locally. Recovery is automatic on re-establishment of communications. Reason for failure may be wiring error, too much bus activity, or damaged 485 drivers.

**T210 (Building Pressure Transducer Failure)** — The building pressure transducer (**Pressures** → **AIR.P** → **BP**) fails if the signal from the 4 to 20 mA building pressure transducer (used to control the power exhaust fans and the building pressure) is below 2 mA. If the alert occurs, then the economizer will be closed and the power exhaust fans turned off. This alert will automatically reset. Check the building pressure transducer and sensor tubing. The sensor is located in the auxiliary control box. The alert will automatically reset.

**T211 (Static Pressure Transducer Failure)** — The static pressure transducer (**Pressures** → **AIR.P** → **SP**) fails if the signal from the 4 to 20 mA static pressure transducer (used to control the VFD speed) is below 2 mA. This failure will cause the unit to stop due to the potential damage that could occur due to over-pressurization. Check the pressure transducer and sensor tubing. The sensor is located in the auxiliary control box. The alert will automatically reset.

**T220 (Indoor Air Quality Sensor Failure)** — The indoor air quality sensor (*Inputs*→*AIR.Q*→*IAQ*) fails if the signal from the 4 to 20 mA sensor is below 2 mA. If the indoor air quality sensor fails, demand control ventilation is not possible. The control defaults to the maximum vent position. Recovery is automatic. Reason for error is either a faulty sensor, wiring error, or damaged input on the MBB control board.

**T221 (Outdoor Air Quality Sensor Failure)** — The indoor air quality sensor (*Inputs*→*AIR.Q*→*OAQ*) fails if the signal from the 4 to 20 mA sensor is below 2 mA. If the outdoor air quality sensor fails, OAQ defaults to 400 ppm and demand control ventilation will continue. Recovery is automatic. Reason for error is either a faulty sensor, wiring error, or damaged input on the CEM control board.

**T229 (Economizer Minimum Position Override Input Failure)** — If the unit is configured to use the remote position override for the economizer and the input Econo Min. Pos. Override (*Configuration*→*IAQ*→*AQ.SP*→*IQ.O.P*) input 4 to 20 mA reading is less than 2 mA then an alert will occur and the default software minimum position will be used for the economizer. The alert will automatically reset.

**T300 (Space Temperature Below Limit)** — If the space temperature is below the configurable SPT Low Alert Limits (occupied [*Configuration*→*ALLM*→*SPL.O*] for 5 minutes or unoccupied [*Configuration*→*ALLM*→*SPL.U*] for 10 minutes), then an alert will be broadcast. The alert will automatically reset.

**T301 (Space Temperature Above Limit)** — If the space temperature is above the configurable SPT High Alert Limits (occupied [*Configuration*→*ALLM*→*SPH.O*] for 5 minutes or unoccupied [*Configuration*→*ALLM*→*SPH.U*] for 10 minutes), then an alert will be broadcast. The alert will automatically reset.

**T302 (Supply Temperature Below Limit)** — If the supply-air temperature measured by the supply temperature sensor is below the configurable SAT LO Alert Limit/Occ (*Configuration*→*ALLM*→*SAL.O*) for 5 minutes or the SAT LO Alert Limit/Unocc (*Configuration*→*ALLM*→*SAL.U*) for 10 minutes, then an alert will be broadcast.

**T303 (Supply Temperature Above Limit)** — If the supply temperature is above the configurable SAT HI Alert Limit Occ (*Configuration*→*ALLM*→*SAH.O*) for 5 minutes or the SAT HI Alert Limit/Unocc (*Configuration*→*ALLM*→*SAH.U*) for 10 minutes, then an alert will be broadcast. The alert will automatically reset.

**T304 (Return Air Temperature Below Limit)** — If the return-air temperature measured by the RAT sensor is below the configurable RAT LO Alert Limit/Occ (*Configuration*→*ALLM*→*RAL.O*) for 5 minutes or RAT HI Alert Limit/Occ (*Configuration*→*ALLM*→*RAL.U*) for 10 minutes, then an alert will be broadcast.

**T305 (Return Air Temperature Above Limit)** — If the return-air temperature is above the RAT HI Alert Limit/Occ (*Configuration*→*ALLM*→*RAH.O*) for 5 minutes or RAT HI Alert Limit/Occ (*Configuration*→*ALLM*→*RAH.U*) for 10 minutes, then an alert will be broadcast. The alert will automatically reset.

**T308 (Return Air Relative Humidity Below Limit)** — If the unit is configured to use a return air relative humidity sensor through the Return Air RH Sensor (*Configuration*→*UNIT*→*SENS*→*RRH.S*) setting, and the measured level is below the configurable RH Low Alert Limit (*Configuration*→*ALLM*→*R.RH.L*) for 5 minutes, then the alert will occur. The unit will continue to run and the alert will automatically reset.

**T309 (Return Air Relative Humidity Above Limit)** — If the unit is configured to use a return air relative humidity sensor through the Return Air RH Sensor (*Configuration*→*UNIT*→*SENS*→*RRH.S*) setting, and the measured level is

above the configurable RH High Alert Limit (*Configuration*→*ALLM*→*R.RH.H*) for 5 minutes, then the alert will occur. Unit will continue to run and the alert will automatically reset.

**T310 (Supply Duct Static Pressure Below Limit)** — If the unit is a VAV unit with a supply duct pressure sensor and the measured supply duct static pressure (*Pressures*→*AIR.P*→*SP*) is below the configurable SP Low Alert Limit (*Configuration*→*ALLM*→*SPL*) for 5 minutes, then the alert will occur. The unit will continue to run and the alert will automatically reset.

**T311 (Supply Duct Static Pressure Above Limit)** — If the unit is a VAV unit with a supply duct pressure sensor and the measured supply duct static pressure (*Pressures*→*AIR.P*→*SP*) is above the configurable SP Low Alert Limit (*Configuration*→*ALLM*→*SPH*) for 5 minutes, then the alert will occur. The unit will continue to run and the alert will automatically reset.

**T312 (Building Static Pressure Below Limit)** — If the unit is configured to use a VFD controlled power exhaust or a modulating power exhaust then a building static pressure limit can be configured using the BP Low Alert Limit (*Configuration*→*ALLM*→*BPL*). If the measured pressure (*Pressures*→*AIR.P*→*BP*) is below the limit for 5 minutes then the alert will occur.

**T313 (Building Static Pressure Above Limit)** — If the unit is configured to use a VFD controlled power exhaust or a modulating power exhaust then a building static pressure limit can be configured using the BP HI Alert Limit (*Configuration*→*ALLM*→*BPH*). If the measured pressure (*Pressures*→*AIR.P*→*BP*) is above the limit for 5 minutes, then the alert will occur.

**T314 (IAQ Above Limit)** — If the unit is configured to use an CO<sub>2</sub> sensor and the level (*Inputs*→*AIR.Q*→*IAQ*) is above the configurable IAQ High Alert Limit (*Configuration*→*ALLM*→*IAQH*) for 5 minutes then the alert will occur. The unit will continue to run and the alert will automatically reset.

**A404 (Fire Shutdown Emergency Mode)** — This alarm occurs when the fire shutdown input is active (either open or closed depending upon its configuration). If the fire shutdown input is energized (fire shutdown is in effect), or if two fire smoke modes are incorrectly energized at the same time, a fire shutdown mode will occur. This is an emergency mode requiring the complete shutdown of the unit. Recovery is automatic when the inputs are no longer on.

This alarm is usually caused by an auxiliary device that is trying to shut down the unit (e.g., smoke detector). The input for Fire Shutdown is at *Inputs*→*FIRE*→*FSD*. The switch logic configuration for this switch input can be found at variable *Configuration*→*SW.LG*→*FSD.L*. Verify that the configuration is set correctly, verify the wiring and auxiliary device. This alarm resets automatically.

**A405 (Evacuation Emergency Mode)** — Unit has been placed in the fire evacuation mode by means of the external command for evacuation (*Inputs*→*FIRE*→*EVAC*).

If the evacuation input on the CEM is energized, an evacuation mode occurs which flags an alarm. This mode attempts to lower the pressure of the space to prevent smoke from moving into another space. This is the reverse of the Pressurization mode. Closing the economizer, opening the return-air damper, turning on the power exhaust, and shutting down the indoor fan will decrease pressure in the space. Recovery is automatic when the input is no longer on.

**A406 (Pressurization Emergency Mode)** — Unit has been placed in the fire pressurization mode by means of the External command for pressurization (*Inputs*→*FIRE*→*PRES*).

If the pressurization input on the CEM is energized, a pressurization mode occurs which flags an alarm. This mode attempts to raise the pressure of a space to prevent smoke



infiltration from another space. The space with smoke should be in an Evacuation mode attempting to lower its pressure. Opening the economizer, closing the return-air damper, shutting down power exhaust, and turning the indoor fan on will increase pressure in the space. Recovery is automatic when the input is no longer on.

**A407 (Smoke Purge Emergency Mode)** — Unit has been placed in the fire pressurization mode by means of the external command for pressurization (**Inputs** → **FIRE** → **PURG**).

If the smoke purge input on the CEM is energized, a smoke purge mode occurs which flags an alarm. This mode attempts to draw out smoke from the space after the emergency condition. Opening the economizer, closing the return-air damper, and turning on both the power exhaust and indoor fan will evacuate smoke and bring in fresh air. Recovery is automatic when the input is no longer on.

**T408 (Dirty Air Filter)** — If no dirty filter switch is installed, the switch will read “clean filter” all the time. Therefore the dirty filter routine runs continuously and diagnoses the input. Because of the different possible times it takes to generate static pressure, this routine waits 2 minutes after the fan starts before the dirty filter switch is monitored. If the dirty filter switch reads “dirty filter” for 2 continuous minutes, an alert is generated. No system action is taken. This is a reminder that it is time to change the filters in the unit. Recovery from this alert is through a clearing of all alarms (manual) or after the dirty filter switch reads clean for 30 continuous seconds (automatic).

Because the Dirty Air Filter switch can be configured normally opened or closed, the switch might be open or closed. The configuration for this switch input can be found at variable **Configuration** → **SW.LG** → **SFS.L**. Verify that the configuration is set correctly. Verify the wiring and filter status switch. The hose should be connected to the low side of the switch. This alert resets automatically. The dirty filter switch is enabled at **Configuration** → **UNIT** → **SENS** → **FLT.S**.

**A409 (Supply Fan Commanded On, Sensed Off Failure)**

**A409 (Supply Fan Commanded Off, Sensed On Failure)**

**T409 (Supply Fan Commanded On, Sensed Off Failure)**

**T409 (Supply Fan Commanded Off, Sensed On Failure)** —

Both the alert and the alarm refer to the same failure. The only difference between the alarm and alert is that in the case where the supply fan status configuration to shut down the unit is set to YES (**Configuration** → **UNIT** → **SFS.S**), the alarm will be generated AND the unit will be shut down. It is possible to configure **Configuration** → **UNITS** → **SFS.M** to either a switch or to monitor a 0.2-in. wg rise in duct pressure if the unit is VAV with duct pressure control.

The timings for failure for both are the same and are illustrated in the following table:

UNIT TYPE/MODE	MINIMUM ON TIME	MINIMUM OFF TIME
CV (no gas heat)	30 seconds	1 minute
CV (gas heat)	2 minutes	4 minutes
VAV (IGV/no gas heat)	2 minutes	4 minutes
VAV (VFD/no gas heat)	1 minute	1 minute
VAV (IGV/gas heat)	4 minutes	4 minutes
VAV (VFD/gas heat)	3 minutes	4 minutes

Recovery is manual. Reason for failure may be a broken fan belt, failed fan relay or failed supply fan status switch.

**T414 (Loss of Communication with Belimo Actuator)** — The Belimo economizer motor is a digital controlled motor. The ComfortLink™ controls can monitor the status of the motor. If there is a problem, this alert will occur. The control will attempt to close the economizer dampers.

**T414 (Belimo Actuator Direction Error)** — This alert occurs when the economizer damper direction switch is in the wrong position. The direction switch should be in the clockwise

position and the actuator should be mounted so that the CW face of the actuator is accessible. Correct if necessary. This alert clears automatically.

**T414 (Belimo Actuator Failure)** — This alert occurs when the commanded damper position is changing too rapidly. This alert resets automatically.

**T414 (Belimo Actuator Jammed)** — This alert occurs when the control software has detected that the damper is stuck. Check the mechanical actuation of the dampers.

**T414 (Belimo Actuator Range Error)** — This alert occurs when the economizer range of motion is less than 90 degrees. Initiate economizer calibration (**Service Test** → **INDP** → **E.CAL**) using the Service Test menu.

**T420 (R-W1 Jumper Must be Installed to Run Heat in Service Test)** — This alert occurs when a request for a heat output has occurred yet the W1 input is not high. A jumper must be installed between R and W1 when trying to test heat in Service Test. The alert will clear when Service Test is exited or if another Service Test mode is selected. Remove jumper when done using Service Test if the unit is operating with a thermostat. The jumper should only be left in place if the unit is operating with a space temperature sensor.

**T421 (Thermostat Y2 Input On without Y1 On)** — This alert occurs in Thermostat Mode when Y2 is energized and Y1 is not. Verify thermostat and thermostat wiring. When Y2 turns on, the software will behave as if Y1 and Y2 are both on. When Y2 turns off, the software will behave as if Y1 and Y2 are both Off. This alert resets automatically when Y1 is turned on.

**T422 (Thermostat W2 Input On without W1 On)** — This alert occurs in Thermostat Mode when W2 is energized and W1 is not. Verify thermostat and thermostat wiring. When W2 turns on, the software will behave as if W1 and W2 are both on. When W2 turns off, the software will behave as if W1 and W2 are both off. This alert resets automatically when W1 is turned on.

**T423 (Thermostat Y and W Inputs On)** — This alert occurs in Thermostat Mode when Y1 or Y2 is energized simultaneously with W1 or W2. Verify thermostat and thermostat wiring. The software will enter either the cooling or heating mode depending upon which input turned on first. This alert resets automatically when Y1 and Y2 are not on simultaneously with W1 and W2.

**T424 (Thermostat G Input Off On a Cooling Call)** — This alert occurs in Thermostat Mode when the fan is not requested (G = ON) during cooling (Y1 or Y2 = ON). Verify thermostat and thermostat wiring.

**T500 (Current Sensor Board Failure – A1)**

**T501 (Current Sensor Board Failure – A2)**

**T502 (Current Sensor Board Failure – B1)**

**T503 (Current Sensor Board Failure – B2)** — Alert codes 500, 501, 502, and 503 are for compressors A1, A2, B1, and B2 respectively. These alerts occur when the output of the current sensor (CS) is a constant high value. These alerts reset automatically. If the problem cannot be resolved and the CS board must be replaced, the CS board can be temporarily disabled while securing a replaced board. A CS board is disabled by setting **Configuration** → **COOL** → **CS.A1**, **CS.A2**, **CS.B1** or **CS.B2** to Disable.

If the current sensor board malfunctions or is not properly connected to its assigned digital input, an alert will be generated. It takes 2 to 4 seconds to log the alert. If the alert is logged, it stays for a minimum of 15 seconds to provide the application a reasonable time to catch the failure. Compressors will be not be inhibited by this failure. Recovery is automatic. Reason for failure may be a faulty current sensor board, incorrect wiring, or a damaged input on the MBB control board.

**A700 (Supply Air Temperature Sensor Failure)** — This alarm indicates a failure of the sensor supply air temperature sensor or the leaving air temperature sensor (if using hydronic heat). This alarm occurs when the temperature sensor (*Temperatures* → *AIR.T* → *SAT*) is outside the range -40 to 240 F (-40 to 116 C). This alarm resets automatically. The cause of the alarm is usually a faulty thermistor, a shorted or open thermistor caused by a wiring error, or a loose connection.

**T701 (Staged Gas 1 Thermistor Failure)**

**T702 (Staged Gas 2 Thermistor Failure)**

**T703 (Staged Gas 3 Thermistor Failure)** — If any of the staged gas thermistors (*Temperatures* → *AIR.T* → *S.GLI-3*) fails, an alert will be generated and the remaining thermistors will be averaged together (*Temperatures* → *AIR.T* → *S.GLS*) without the failed thermistor. Recovery is automatic. Reason for failure may be incorrect wiring, faulty thermistor, or a damaged input on the staged gas control board (SCB).

**A704 (Staged Gas Leaving Air Temperature Sum Total Failure)** — If all three staged gas thermistors (*Temperatures* → *AIR.T* → *S.GLI-3*) fail (the sensor is outside the range of -40 F to 240 F), staged gas will be shut down and this alarm will be generated. Recovery is automatic. Reason for failure may be faulty wiring, faulty thermistors, or damaged inputs on the staged gas control board (SCB).

**T705 (Limit Switch Thermistor Failure)** — A failure (the sensor is outside the range of -40 F to 240 F) of this thermistor (*Temperatures* → *AIR.T* → *S.GLM*) will cause an alert to occur and a disabling of the limit switch monitoring function for the staged gas control board (SCB). Recovery is automatic. Reason for failure may be due to faulty wiring, a faulty thermistor, or a damaged input on the staged gas control board (SCB).

## MAJOR SYSTEM COMPONENTS

**General** — The 48/50A Series package rooftop units with electric cooling and with gas heating (48A units) or electric cooling and electric heating (50A units) contain the *ComfortLink* electronic control system that monitors all operations of the rooftop. The control system is composed of several components as listed below. See Fig. 15-23 for typical control and power component schematics. Figures 24 and 25 show the layout of the control box, unit, and thermistor and transducer locations.

### Factory-Installed Components

**MAIN BASE BOARD (MBB)** — See Fig 26. The MBB is the center of the *ComfortLink* control system. The MBB contains the major portion of the operating software and controls the operation of the unit. The MBB has 22 inputs and 11 outputs. See Table 115 for the inputs and output assignments. The MBB also continuously monitors additional data from the optional ECB1, ECB2, SCB, and CEM boards through the LEN communications port. The MBB also interfaces with the Carrier Comfort Network® system through the CCN communications port. The board is located in the main control box.

**ECONOMIZER BOARD (ECB1)** — The ECB1 controls the economizer actuator and the power exhaust fans. The ECB1 operates the economizer motor using a digital communication

signal that also provides status and diagnostics for the economizer motor. See Fig. 27. The ECB1 also controls the operation of the power exhaust motors and provides up to 6 stages of digitally sequenced power exhaust either based on the economizer motor position or the building pressure. The board has 4 inputs and 6 outputs. Additionally, ECB1 provides an output that will send a 4 to 20 mA signal to a field-installed VFD power exhaust accessory. Details can be found in Table 116. The ECB1 board is located in an auxiliary box located at the end of the unit behind the filter access door. The board also contains a second LEN port than can be used with the accessory Navigator™ display.

**VAV BOARD (ECB2)** — The VAV board (which is the same hardware as the ECB1) is used to control the supply fan on VAV units. See Fig. 27. It sends a 4 to 20 mA signal to the VFD based on a supply duct pressure sensor connected to the board. The board also accepts a signal from another pressure sensor that monitors building pressure and controls the operation of the optional modulating power exhaust motors. The board will also be used on CV units with the optional building pressure control feature and modulating power exhaust. This board is also used to control a digitally controlled hot gas bypass solenoid with an integral orifice for use in low load applications. This board is located in the auxiliary control box. Input and output assignments are summarized in Table 117.

**STAGED GAS HEAT BOARD (SCB)** — When optional staged gas heat is used on CV and VAV units, the SCB board is installed and controls operation of the gas valves. See Fig. 28. The SCB also provides additional sensors for monitoring of the supply-air temperature. This board is located in the gas heat section of the unit. The inputs and outputs are summarized in Table 118.

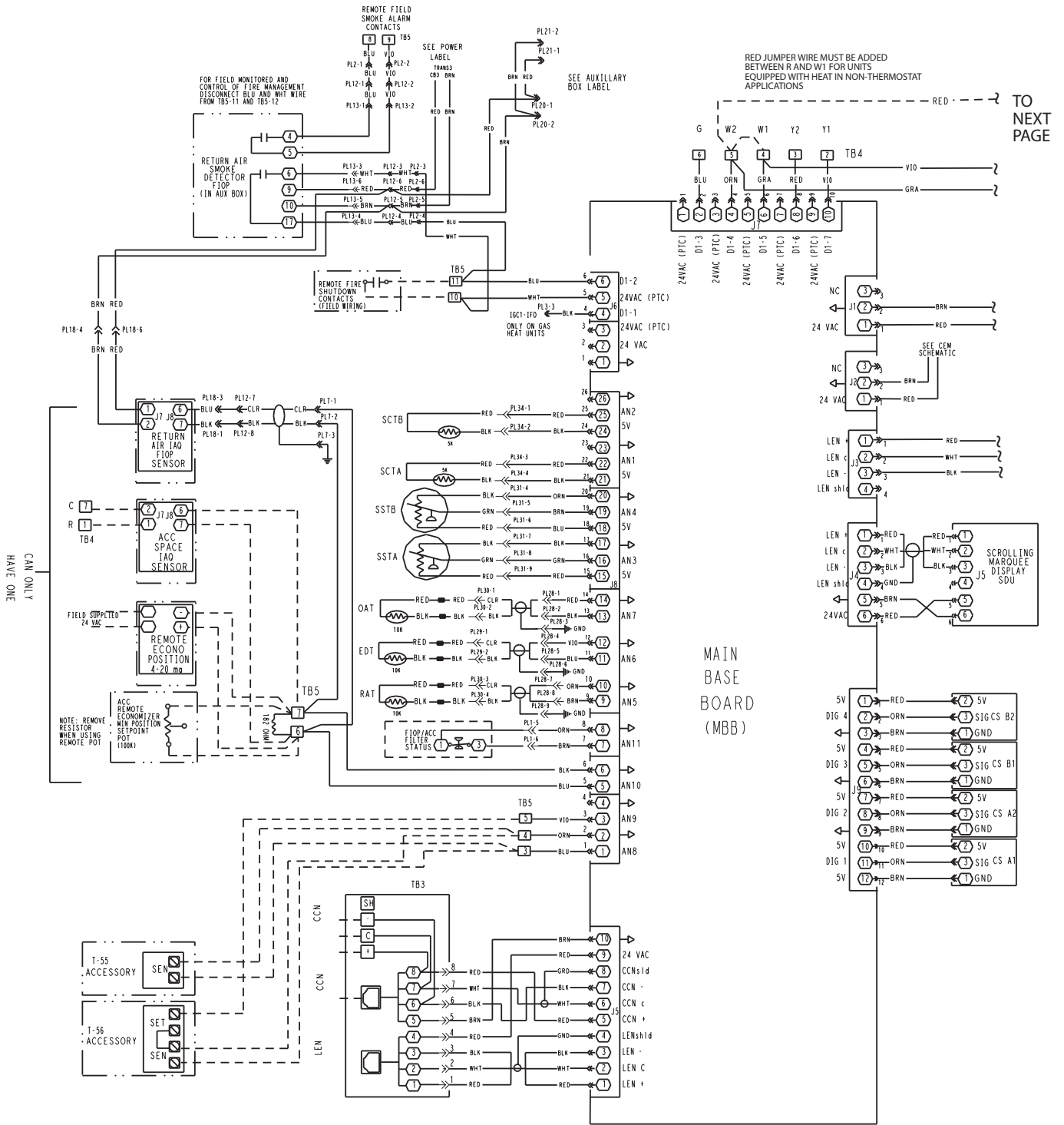
**CONTROL EXPANSION MODULE (CEM)** — The optional CEM (also available as an accessory) is used to accept inputs for additional sensors or control sequence switches, including:

- smoke control mode field switches
- VAV Supply Air Temperature Set Point reset using an external 4 to 20 mA signal
- outdoor air CO<sub>2</sub> sensor (for supply duct pressure reset using an external 4 to 20 mA signal)
- external fan status pressure switch input (CV units)
- demand limit sequence proportional signal or discrete switches

The CEM board is located in the main control box. See Fig. 29. The inputs and outputs are summarized in Table 119.

**INTEGRATED GAS CONTROL (IGC)** — One IGC is provided with each bank of gas heat exchangers (2 used on the size 020-050 units and 3 on size 051 and 060 units). The IGC controls the direct spark ignition system and monitors the rollout switch, limit switches, and induced-draft motor Hall Effect switch. The IGC is equipped with an LED (light-emitting diode) for diagnostics. See Table 120.

**COMPRESSOR PROTECTION BOARD (CS)** — This board monitors the status of the compressor by sensing the current flow to the compressors and then provides digital status signal to the MBB.



**Fig. 15 — Typical Main Control Box Wiring Schematic (48/50AJ,AK,AW,AY Units)**



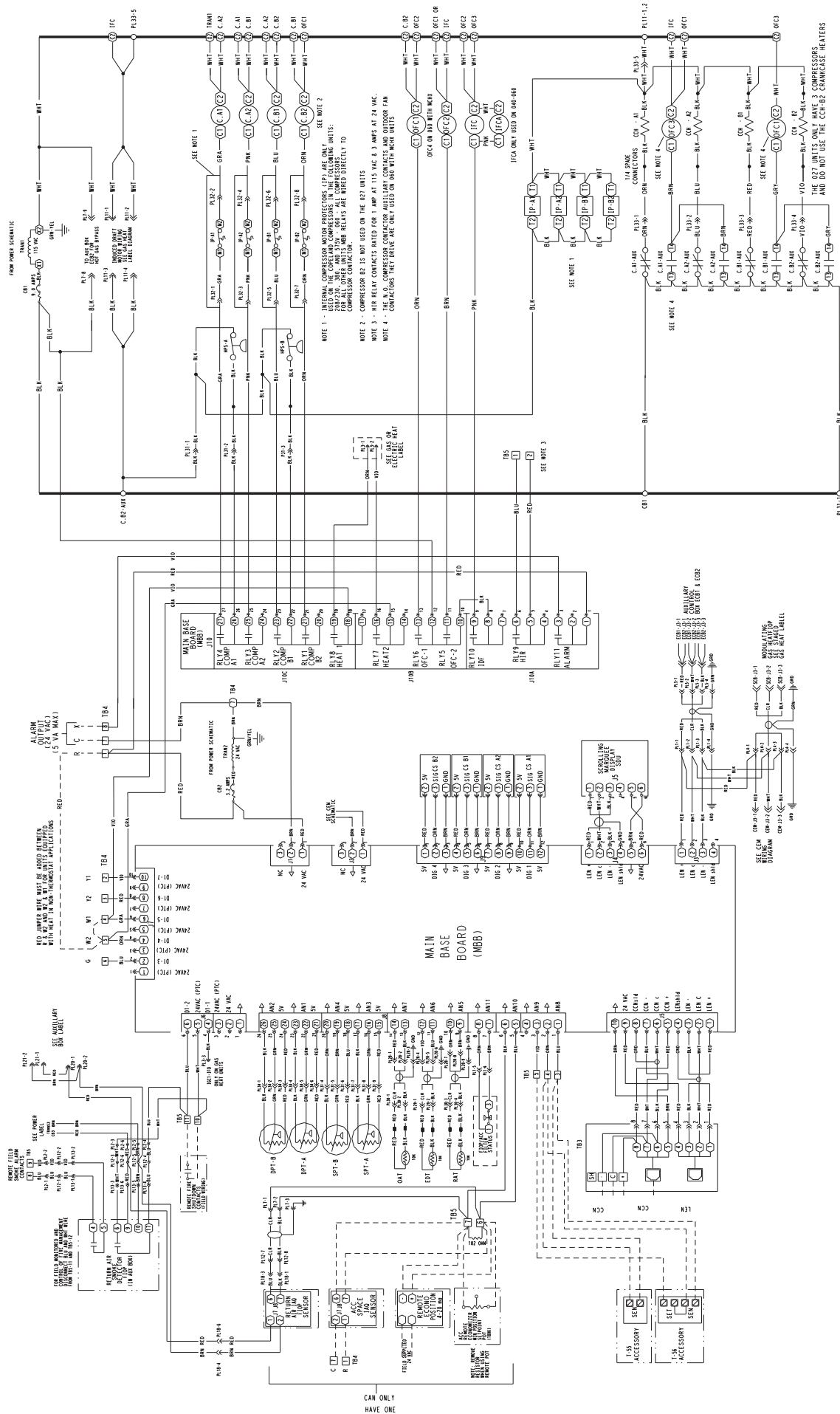
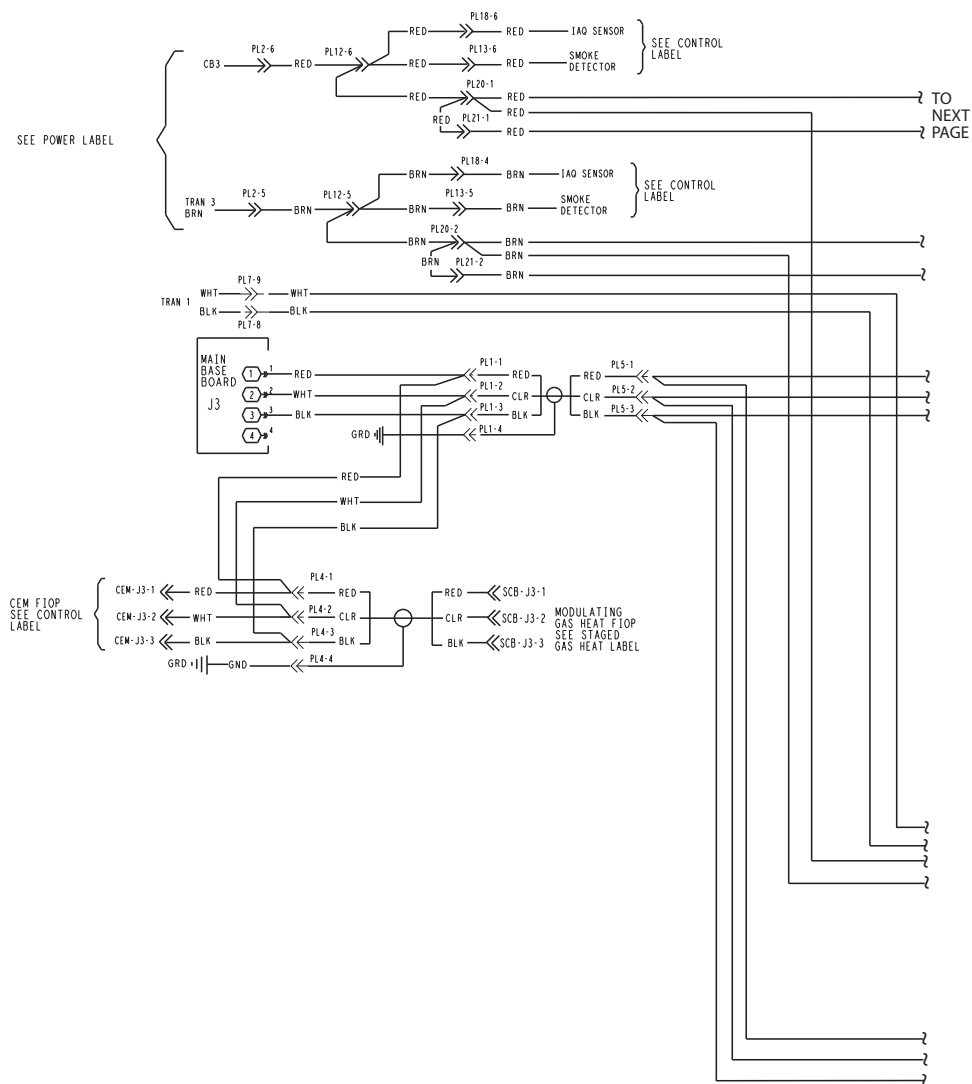
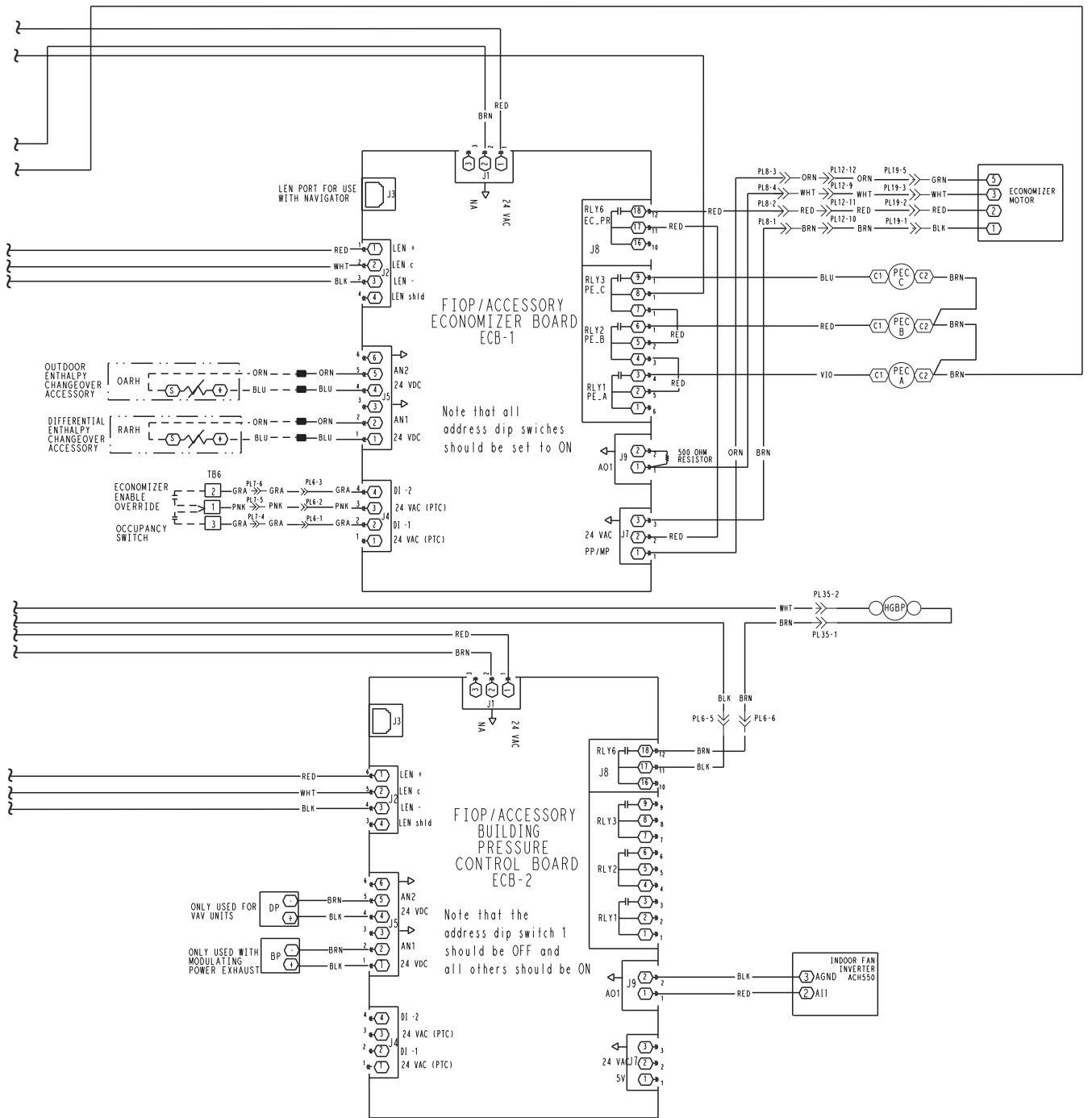


Fig. 16 — Typical Main Control Box Wiring Schematic (48/50A2, A3, A4, A5 Units)



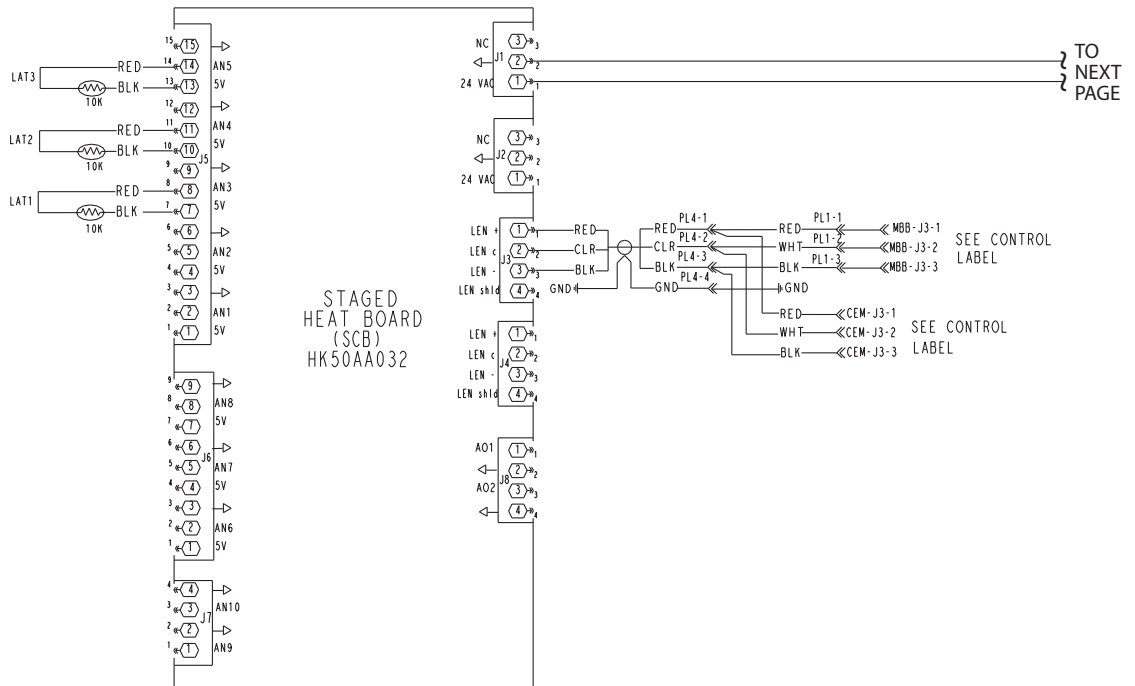
**Fig. 17 — Typical Auxiliary Control Box Wiring Schematic**



**Fig. 17 — Typical Auxiliary Control Box Wiring Schematic (cont)**

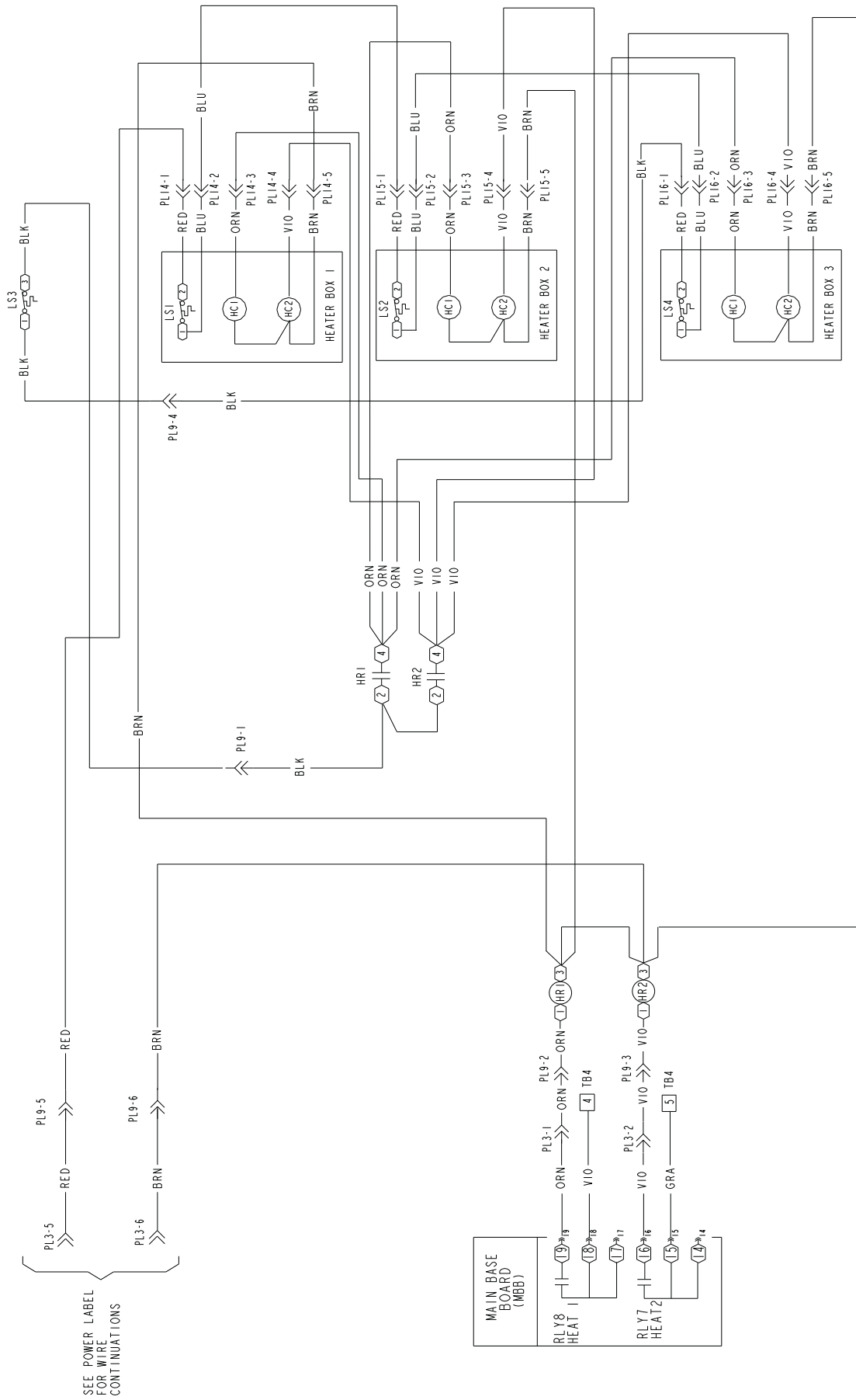






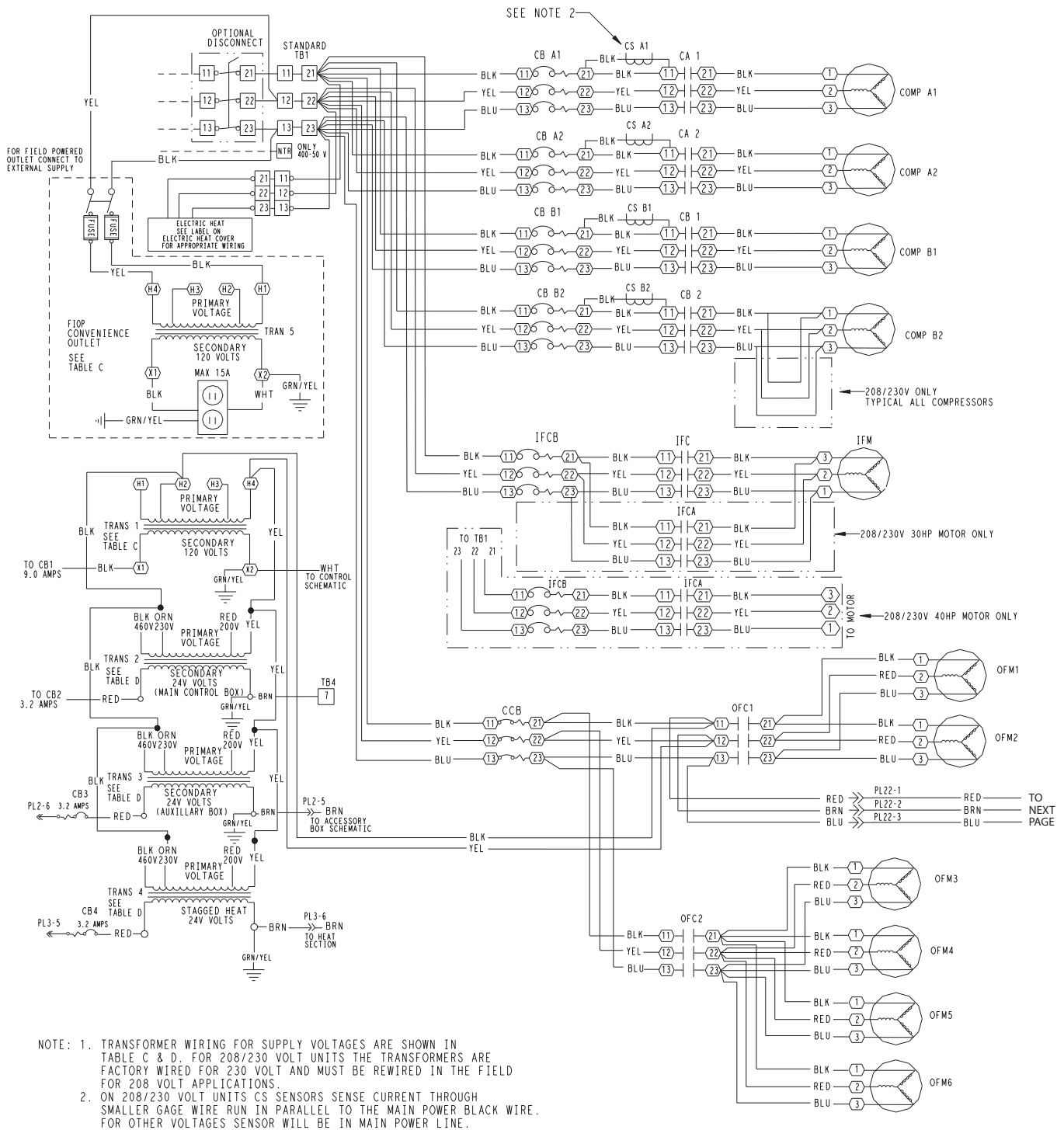
**Fig. 19 — Typical Staged Gas Heat Wiring Schematic (Size 051 and 060 Units Shown)**





SEE POWER LABEL  
FOR WIRE  
CONTINUATIONS

Fig. 20 — Typical Electric Heat Control Schematic — (50 Series Size 051 and 060 Units Shown)



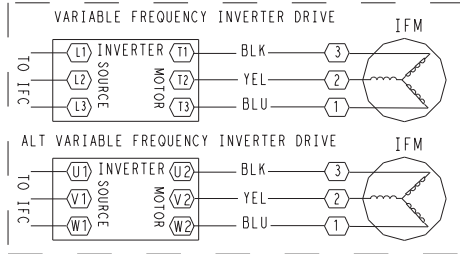
**Fig. 21 — Typical Power Schematic (48/50AJ,AK,AW,AY051 and 060 Units Shown)**

TABLE C

208-230/460V TRANSFORMER	CONNECT	H1 460V H2 230V H3 208V H4 COMM
PRIMARY VOLTAGE: 460V 230V 208V COMM	H1 (BLK) H2 (BLK) H3 (BLK) H4 (YEL)	X2 X1
SECONDARY VOLTAGE 115V	X1 (BLK) X2 (YEL)	115V
COMM		
575V TRANSFORMER	CONNECT	H1 575V H2 95V H3 115V H4 COMM
PRIMARY VOLTAGE: 575V	H1 (BLK) H4 (YEL)	X3 X2 X1
SECONDARY VOLTAGE 115V	X1 (BLK) X3 (YEL)	115V
COMM		
400V TRANSFORMER	CONNECT	H1 415V H2 400V H3 380V H4 COMM
PRIMARY VOLTAGE: 400V 380V	H2 (BLK) H3 (BLK) H4 (YEL)	X4 X3 X2 X1
SECONDARY VOLTAGE 115V	X1 (BLK) X2-X4 X1-X3 X4 (YEL)	115V
COMM		

TABLE D

208-230/460V TRANSFORMER	CONNECT	BLK 460V ORN 230V RED 208V YEL COMM
PRIMARY VOLTAGE: 460V 230V 208V COMM	BLK ORN RED YEL	24V COMM
SECONDARY VOLTAGE 24V	X1 (BLK) X2 (YEL)	COMM
COMM		
575V TRANSFORMER	CONNECT	BLK 600V YEL COMM
PRIMARY VOLTAGE: 575V	BLK YEL	24V COMM
SECONDARY VOLTAGE 24V	X1 (BLK) X3 (YEL)	COMM
COMM		
400V TRANSFORMER	CONNECT	BLK 400V YEL COMM
PRIMARY VOLTAGE: 400V 380V	BLK YEL	24V COMM
SECONDARY VOLTAGE 24V	X1 (BLK) X4 (YEL)	COMM
COMM		



POWER EXHAUST FIOP AND ACCESSORY

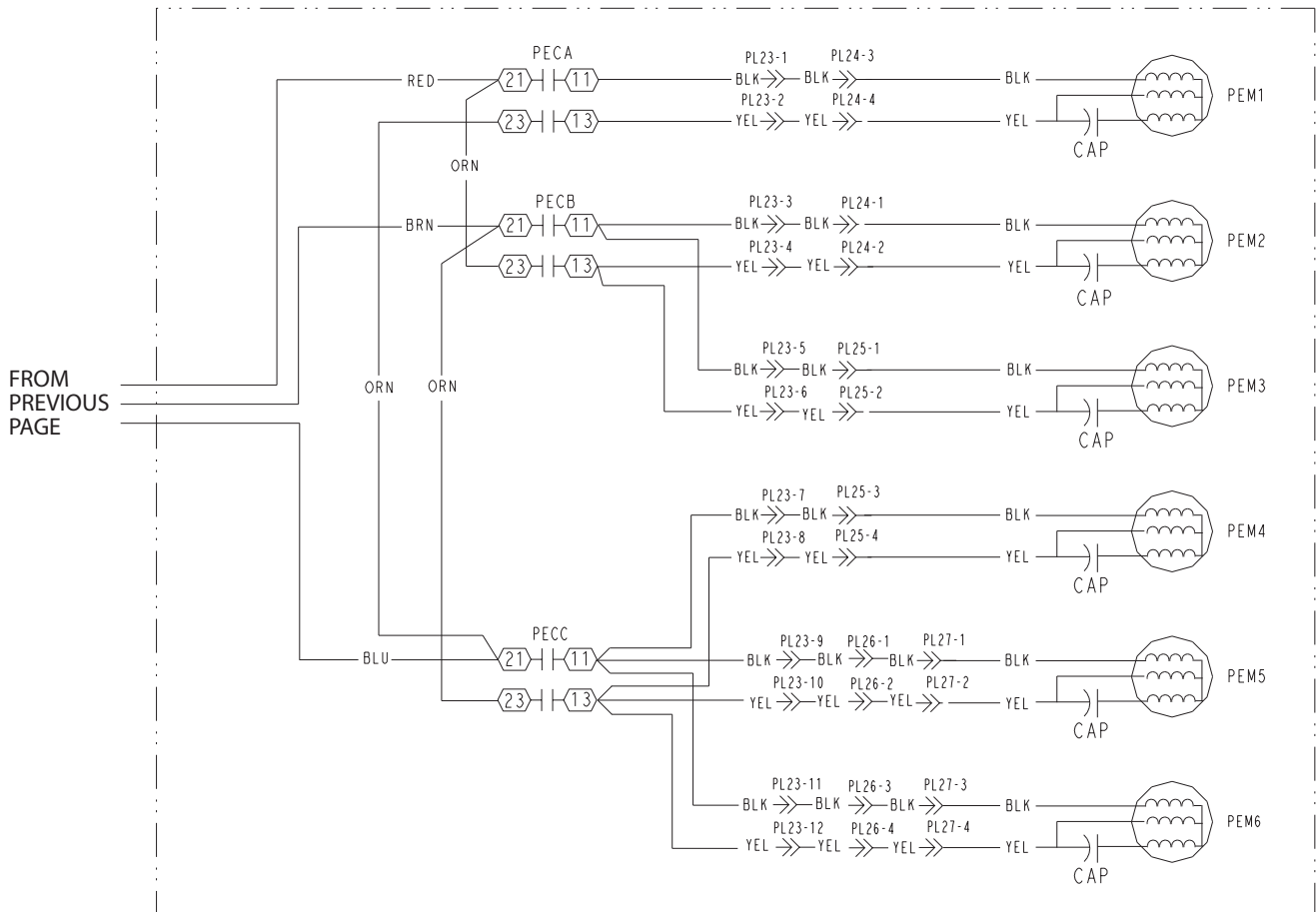
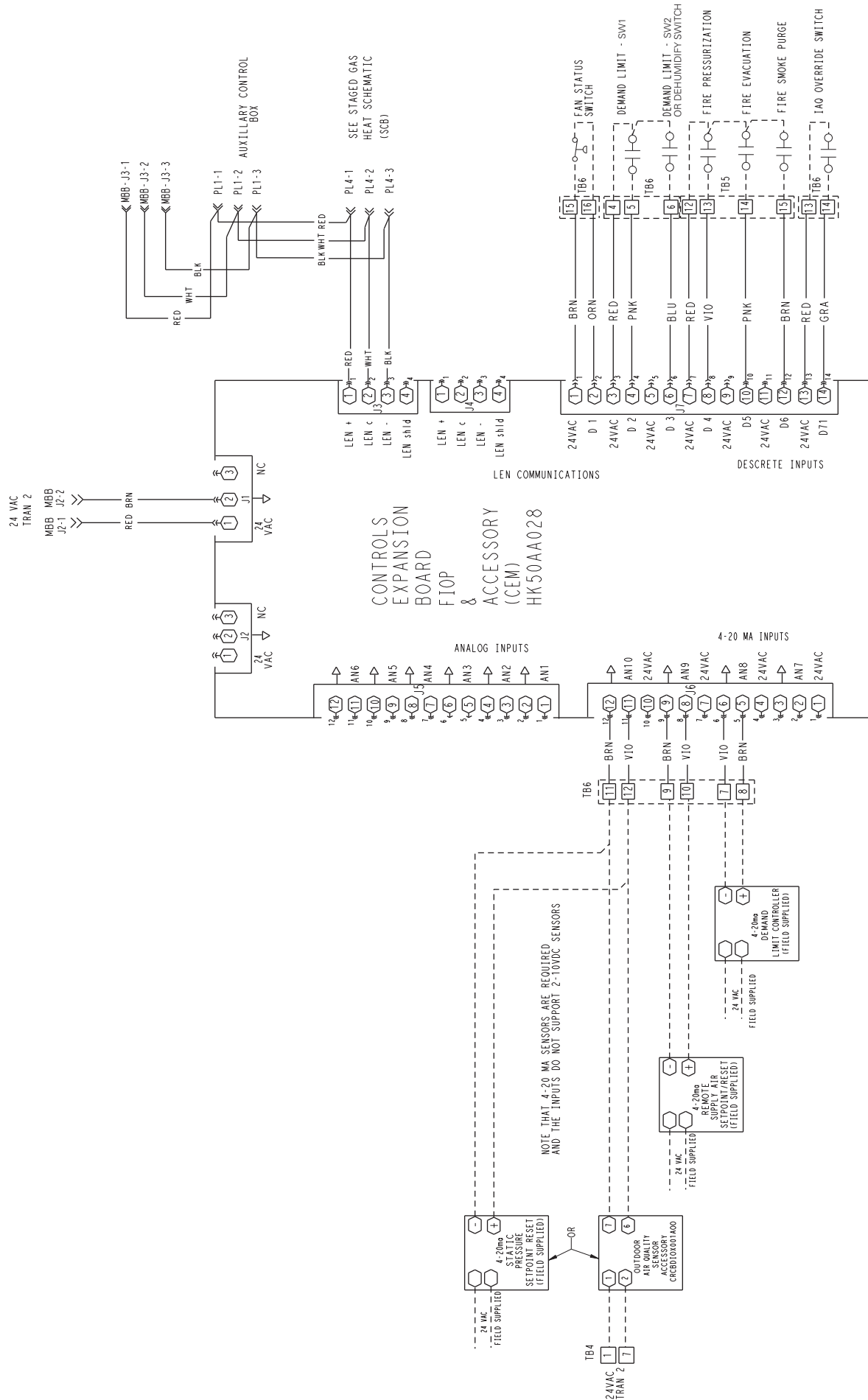


Fig. 21 — Typical Power Schematic (48/50AJ,AK,AW,AY051 and 060 Units Shown) (cont)



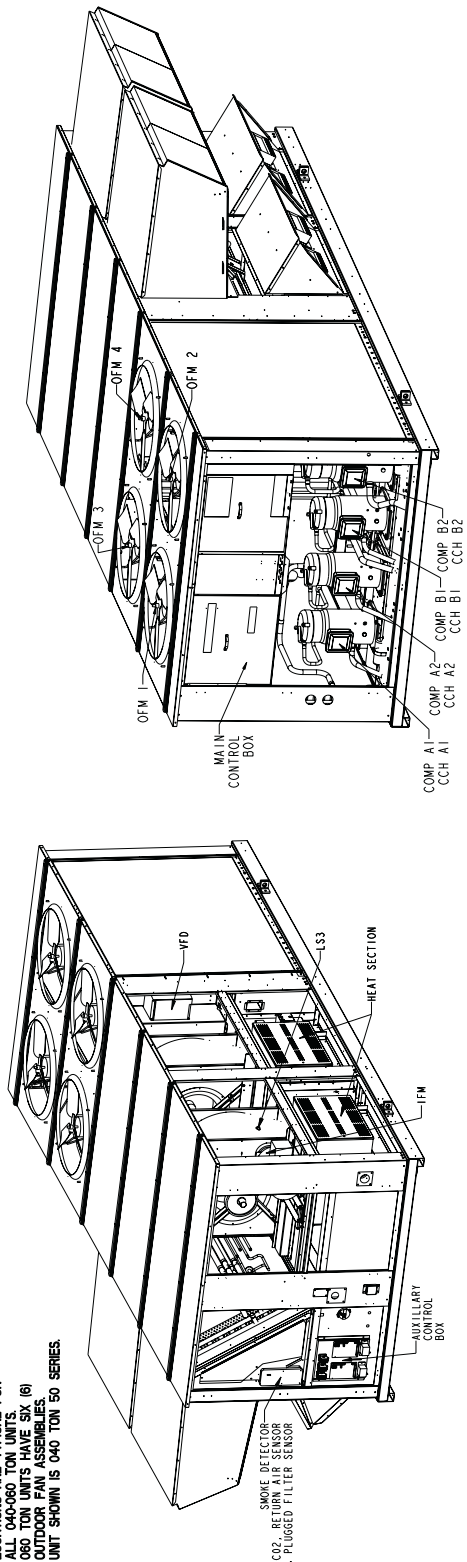


**Fig. 23 — Typical Controls Option Wiring Schematic**

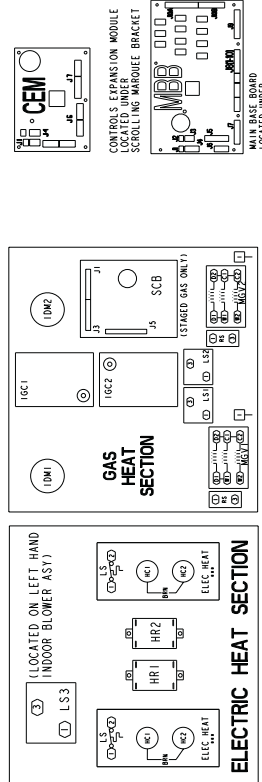




LOCATIONS ARE TYPICAL FOR ALL 040-060 TON UNITS. 060 TON UNITS HAVE SIX (6) OUTDOOR FAN ASSEMBLIES. UNIT SHOWN IS 040 TON 50 SERIES.

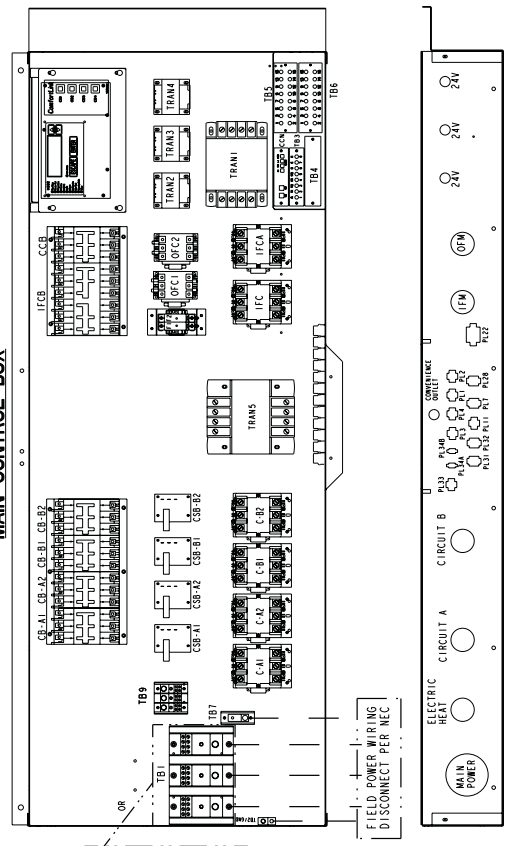
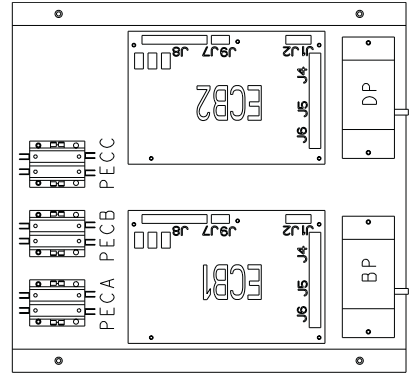


COMP A1  
CCH A1  
COMP A2  
CCH A2  
COMP B1  
CCH B1  
COMP B2  
CCH B2



**MAIN CONTROL BOX**

**AUXILIARY CONTROL BOX**



**BOTTOM VIEW OF CONTROL BOX**









**Fig. 25 — Typical Large Chassis Component Locations (Size 036-060 Units)**

## LEGEND AND NOTES FOR FIG. 15-25

### LEGEND

<b>A</b>	—	Circuit A
<b>AUX</b>	—	Auxiliary Contact
<b>B</b>	—	Circuit B
<b>BP</b>	—	Building Pressure Transducer
<b>C</b>	—	Contact, Compressor
<b>CAP</b>	—	Capacitor
<b>CB</b>	—	Circuit Breaker
<b>CCB</b>	—	Control Circuit Breaker
<b>CCH</b>	—	Crankcase Heater
<b>CCN</b>	—	Carrier Comfort Network®
<b>CEM</b>	—	Controls Expansion Module
<b>COMP</b>	—	Compressor Motor
<b>CR</b>	—	Control Relay
<b>CS</b>	—	Compressor Safety
<b>CSB</b>	—	Compressor Current Sensing Board
<b>DP</b>	—	Duct Pressure Sensor
<b>DPT</b>	—	Discharge Pressure Transducer
<b>DS</b>	—	Disconnect Switch
<b>ECB-1</b>	—	Economizer Control Board
<b>ECB-2</b>	—	Building and Supplier Air Control Board
<b>EDT</b>	—	Evaporator Discharge Air Temperature
<b>FIOP</b>	—	Factory-Installed Option
<b>FS</b>	—	Flame Sensor
<b>FU</b>	—	Fuse
<b>GND</b>	—	Ground
<b>HC</b>	—	Heat Contactor
<b>HGBP</b>	—	Hot Gas Bypass
<b>HIR</b>	—	Heat Interlock Relay
<b>HPS</b>	—	High Pressure Switch
<b>HR</b>	—	Heat Relay
<b>HS</b>	—	Hall Effect Induced Draft Motor Switch
<b>IAQ</b>	—	Indoor Air Quality
<b>IDF</b>	—	Induced Draft Fan
<b>IDM</b>	—	Induced Draft Motor
<b>IFC</b>	—	Indoor Fan Contactor
<b>IFCB</b>	—	Indoor Fan Circuit Breaker
<b>IFM</b>	—	Indoor Fan Motor
<b>IGC</b>	—	Integrated Gas Control Board
<b>IP</b>	—	Internal Compressor Protector
<b>LAT</b>	—	Staged Gas Temperature Sensor
<b>LEN</b>	—	Local Equipment Network
<b>LS</b>	—	Limit Switch
<b>MBB</b>	—	Main Base Board
<b>MGV</b>	—	Main Gas Valve
<b>NEC</b>	—	National Electrical Code
<b>OARH</b>	—	Outdoor Air Relative Humidity
<b>OAT</b>	—	Outdoor Air Temperature Sensor
<b>OFC</b>	—	Outdoor Fan Contactor
<b>OFM</b>	—	Outdoor Fan Motor
<b>PEC</b>	—	Power Exhaust Contactor
<b>PEM</b>	—	Power Exhaust Motor

<b>PL</b>	—	Plug
<b>RARH</b>	—	Return Air Relative Humidity
<b>RAT</b>	—	Return Air Temperature Sensor
<b>RLA</b>	—	Rated Load Amps
<b>RLY</b>	—	Relay
<b>RS</b>	—	Rollout Switch
<b>SCB</b>	—	Staged Gas Heat Control Board
<b>SCT</b>	—	Saturated Condensing Temperature Sensor
<b>SDU</b>	—	Scrolling Marquee Display
<b>SST</b>	—	Saturated Suction Temperature Sensor
<b>T-55</b>	—	Room Temperature Sensor
<b>T-56</b>	—	Room Temperature Sensor with Setpoint
<b>TB</b>	—	Terminal Block
<b>TRAN</b>	—	Transformer
<b>VAV</b>	—	Variable Air Volume
<b>VFD</b>	—	Variable Frequency Drive

	Terminal Block
	Terminal (Unmarked)
	Terminal (Marked)
	Splice
	Factory Wiring
	Field Wiring
	To indicate common potential only. Not to represent wiring.
	To Indicate FIOP or Accessory

#### THERMOSTAT MARKINGS

<b>BM</b>	—	Blower Motor
<b>C</b>	—	Common
<b>CM</b>	—	Inducer Motor
<b>CS</b>	—	Centrifugal Switch
<b>G</b>	—	Fan
<b>IFO</b>	—	Indoor Fan On
<b>L1</b>	—	Line 1
<b>R</b>	—	Thermostat Power
<b>RT</b>	—	Power Supply
<b>SS</b>	—	Speed Sensor
<b>W1</b>	—	Thermostat Heat Stage 1
<b>W2</b>	—	Thermostat Heat Stage 2
<b>X</b>	—	Alarm Output
<b>Y1</b>	—	Thermostat Cooling Stage 1
<b>Y2</b>	—	Thermostat Cooling Stage 2

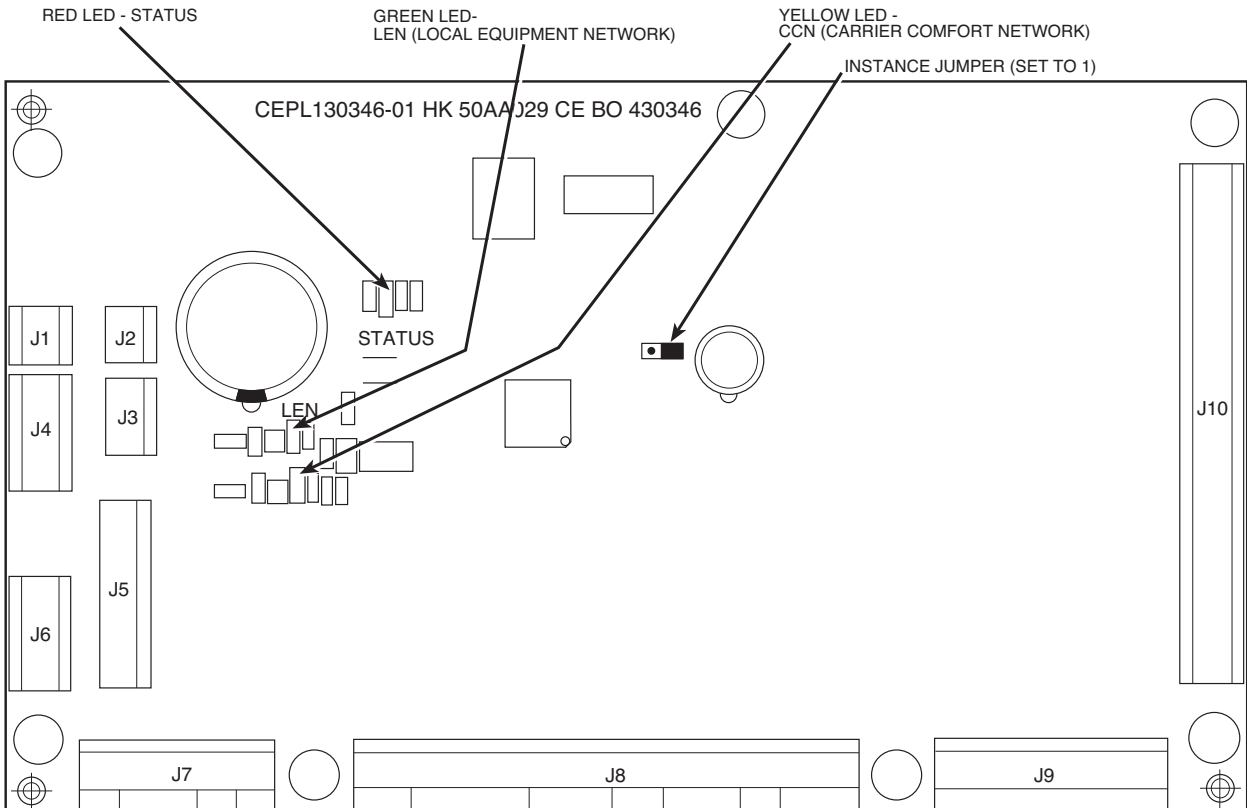
#### NOTES:

1. Factory wiring is in accordance with the National Electrical Codes. Any field modifications or additions must be in compliance with all applicable codes.
2. Use 75° C min wire for field power supply, use copper wires for all units.
3. All circuit breakers "Must Trip Amps" are equal to or less than 156% RLA.
4. Compressor and fan motors are thermally protected — three phase motors protected against primary single phase conditions.
5. Red jumper wire must be added between R, W1, and W2 for space temperature sensor and all VAV units with heat and temporarily during Service Test mode when the heaters need to operate.

**Table 115 — Main Control Board (MBB) Inputs and Outputs**

POINT NAME	POINT DESCRIPTION	I/O POINT NAME	PLUG AND PIN REFERENCE	SIGNAL PIN(S)	PORT STATE
<b>INPUTS</b>					
GASFAN	YAC Indoor Fan relay (fan request from YAC)	DI1	J6, 3-4	4	0 = 24vac, 1= 0vac
FSD	Fire Shutdown switch input	DI2	J6, 5-6	6	0 = 24vac, 1= 0vac
G	Thermostat 'G' input	DI3	J7, 1-2	2	0 = 24vac, 1= 0vac
W2	Thermostat 'W2' input	DI4	J7, 3-4	4	0 = 24vac, 1= 0vac
W1	Thermostat 'W1' input	DI5	J7, 5-6	6	0 = 24vac, 1= 0vac
Y2	Thermostat 'Y2' input	DI6	J7, 7-8	8	0 = 24vac, 1= 0vac
Y1	Thermostat 'Y1' input	DI7	J7, 9-10	10	0 = 24vac, 1= 0vac
CSB_A1	Compressor A1 current sensor	DIG1	J9, 10-12	10=5v, 11=Vin, 12=GND	0 = 5vdc, 1 = 0vdc
CSB_A2	Compressor A2 current sensor	DIG2	J9, 7-9	7=5v, 8=Vin, 9=GND	0 = 5vdc, 1 = 0vdc
CSB_B1	Compressor B1 current sensor	DIG3	J9, 4-6	4=5v, 5=Vin, 6=GND	0 = 5vdc, 1 = 0vdc
CSB_B2	Compressor B2 current sensor	DIG4	J9, 1-3	1=5v, 2=Vin, 3=GND	0 = 5vdc, 1 = 0vdc
DP_A/SCTA	Circuit A saturated condensing pressure/temp	AN1	J8, 21-23	21=5v, 22=Vin, 23=GND (thermistor 21-22)	(0-5vdc, thermistor, ohms)
DP_B/SCTB	Circuit B saturated condensing pressure/temp	AN2	J8, 24-26	24=5v, 25=Vin, 26=GND (thermistor 24-25)	(0-5vdc, thermistor, ohms)
SP_A/SSTA	Circuit A saturated suction pressure/temp	AN3	J8, 15-17	15=5v, 16=Vin, 17=GND (thermistor 15-16)	(0-5vdc, thermistor, ohms)
SP_B/SSTB	Circuit B saturated suction pressure/temp	AN4	J8, 18-20	18=5v, 19=Vin, 20=GND (thermistor 18-20)	(0-5vdc, thermistor, ohms)
RAT	Return air temperature	AN5	J8, 9-10	9	(thermistor, ohms)
SA_TEMP	Supply air temperature	AN6	J8, 11-12	11	(thermistor, ohms)
OAT	Outdoor air temperature	AN7	J8, 13-14	13	(thermistor, ohms)
SPT	Space temperature (T55/56)	AN8	J8, 1-2	1	(thermistor, ohms)
SPTO	Space temperature offset (T56)	AN9	J8, 3-4	3	(thermistor, ohms)
IAQ/IAQMINOV	IAQ analog input	AN10	J8, 5-6	5	(thermistor, ohms)
FLTS	Filter Status	AN11	J8, 7-8	7	(thermistor, ohms)
<b>OUTPUTS</b>					
CMPB2	Compressor B2	RLY 1	J10, 20-21	20 = RLY1A (=RLY2A), 21 = RLY1B	1 = Closes RLY1A/RLY1B
CMPB1	Compressor B1	RLY 2	J10, 22-23	22 = RLY2A (=RLY1A), 23 = RLY2B	1 = Closes RLY2A/RLY2B
CMPA2	Compressor A2	RLY 3	J10, 24-25	24 = RLY3A (=RLY4A), 25 = RLY3B	1 = Closes RLY3A/RLY3B
CMPA1	Compressor A1	RLY 4	J10, 26-27	26 = RLY4A (=RLY3A), 27 = RLY4B	1 = Closes RLY4A/RLY4B
CONDFANB	Condenser fan B	RLY 5	J10, 10-11	10 = RLY5A (=RLY6A), 11 = RLY5B	1 = Closes RLY5A/RLY5B
CONDFANA	Condenser fan A	RLY 6	J10, 12-13	12 = RLY6A (=RLY5A), 13 = RLY6B	1 = Closes RLY6A/RLY6B
HS2	Heat stage 2	RLY7	J10, 14-16	14 = 15 = RLY7A, 16 = RLY7B	1 = Closes RLY7A/RLY7B
HS1	Heat stage 1	RLY 8	J10, 17-19	17 = 18 = RLY8A, 19 = RLY8B	1 = Closes RLY8A/RLY8B
HIR	Heat interlock relay	RLY 9	J10, 4-6	4 = 5 = RLY9A, 6 = RLY9B	1 = Closes RLY9A/RLY9B
SF	Supply fan	RLY 10	J10, 7-9	7 = 8 = RLY10A, 9 = RLY10B	1 = Closes RLY10A/RLY10B
ALRM	Alarm output relay	RLY 11	J10, 1-3	1 = 2 = RLY11A, 3 = RLY11B	1 = Closes RLY11A/RLY11B

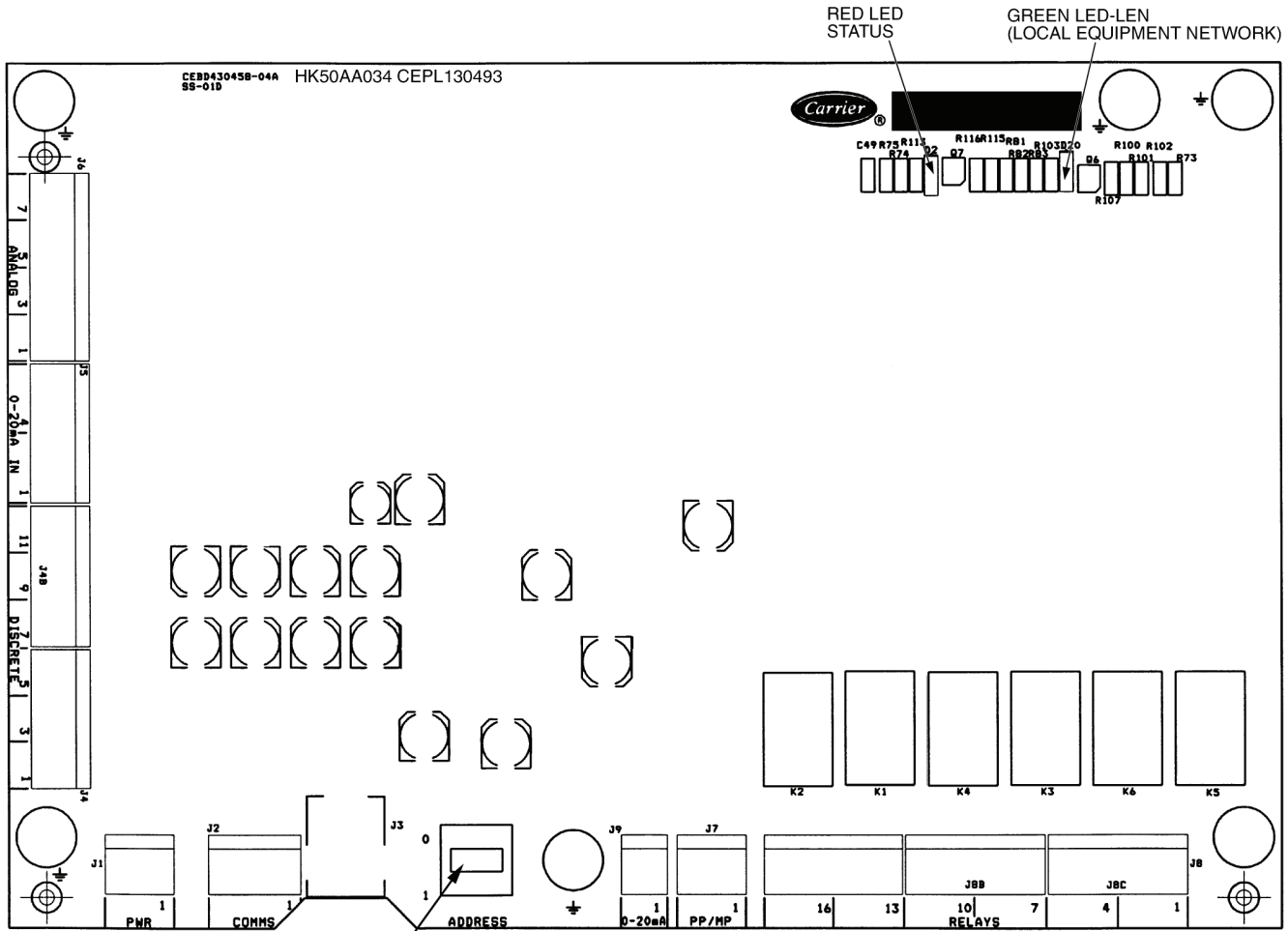
YAC — Gas Heat Unit



**Fig. 26 — Main Base Board (MBB)**

**Table 116 — Economizer Control Board (ECB1) Inputs and Outputs**

POINT NAME	POINT DESCRIPTION	I/O POINT NAME	PLUG AND PIN REFERENCE	SIGNAL PIN(S)	PORT STATE
<b>INPUTS</b>					
RMTIN	Remote occupancy	DI1	J4, 1-2	2	24VAC = 1, 0VAC = 0
ECONENBL, ECOORIDE	Economizer enable	DI2	J4, 3-4	4	24VAC = 1, 0VAC = 0
RARH	Return air relative humidity	AN1	J5, 1-3	1=24VDC, 2=0-20mA in, 3=GND	0-20mA
OARH	Outdoor air relative humidity	AN2	J5, 4-6	4=24VDC, 5=0-20mA in, 6=GND	0-20mA
<b>OUTPUTS</b>					
ECB1_AO1	ECB1, analog output 1	AO1	J9, 1-2	1=0-20mA, 2=GND	0-20mA OUT
ECONOCMD	Economizer actuator (digital control)	PP/MP	J7, 1-3	1=PP/MP Data, 2=24VAC, 3=GND	Belimo PP/MP Protocol
PE_A	Power Exhaust stage A	RLY1	J8, 1-3	1 = 2 = RLY1A, 3 = RLY1B	1 = Closes RLY1A/RLY1B
PE_B	Power Exhaust stage B	RLY 2	J8, 4-6	4 =5 = RLY2A, 6 = RLY2B	1 = Closes RLY2A/RLY2B
PE_C	Power Exhaust stage C	RLY 3	J8, 7-9	7 = 8 = RLY3A, 9 = RLY3B	1 = Closes RLY3A/RLY3B
ECON_PWR	Economizer Power	RLY 6	J8, 16-18	16 = 17 = RLY6A, 18 = RLY6B	1 = Closes RLY6A/RLY6B

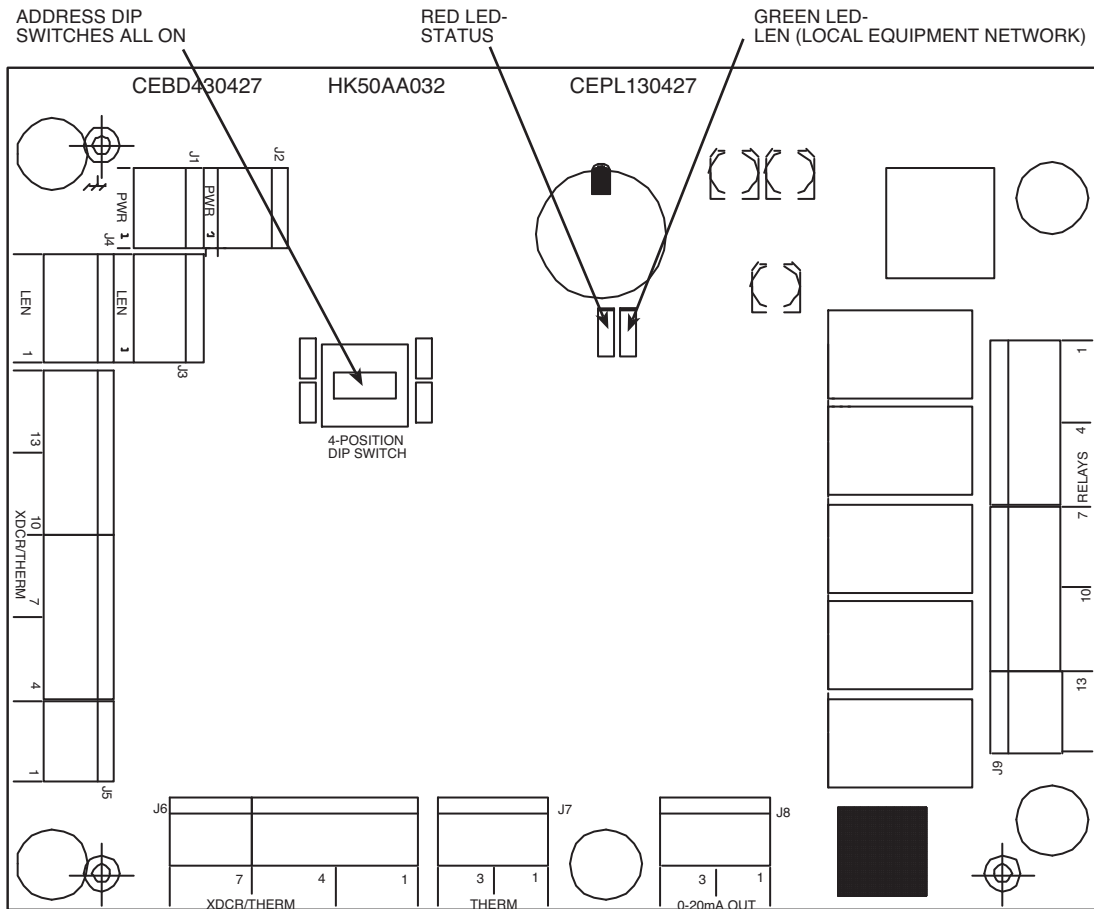


ADDRESS DIP SWITCHES  
 RCB - 1-4 ON  
 ECB - 1-OFF, 2-4 ON

**Fig. 27 — Economizer Control Board (ECB1) and VAV Control Board (ECB2)**

**Table 117 — VAV Control Board (ECB2) Inputs and Outputs**

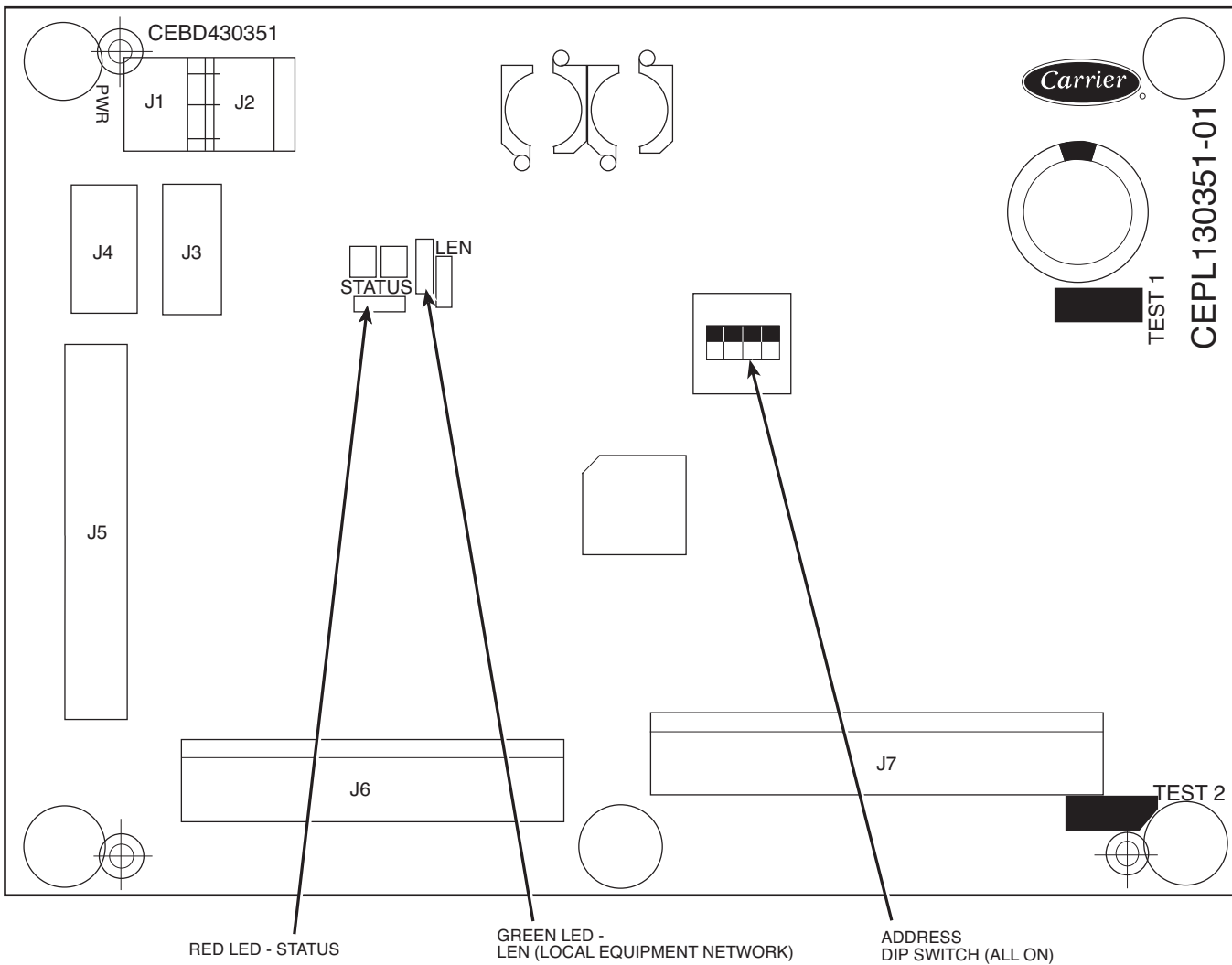
POINT NAME	POINT DESCRIPTION	I/O POINT NAME	PLUG AND PIN REFERENCE	SIGNAL PIN(S)	PORT STATE
<b>INPUTS</b>		DI1	J4, 1-2	2	24VAC = 1, 0VAC = 0
		DI2	J4, 3-4	4	24VAC = 1, 0VAC = 0
<b>BP</b>	Building static pressure	AN1	J5, 1-3	1=24VDC, 2=0-20mA in, 3=GND	0-20mA
<b>SP</b>	Supply Duct static pressure	AN2	J5, 4-6	4=24VDC, 5=0-20mA in, 6=GND	0-20mA
<b>OUTPUTS</b>					
<b>SFAN_VFD</b>	Supply Fan Inverter speed	AO1	J9, 1-2	1=0-20mA, 2=GND	0-20mA OUT
		PP/MP	J7, 1-3	1=PP/MP Data, 2=24VAC, 3=GND	Belimo PP/MP Protocol
		RLY1	J8, 1-3	1 = 2 = RLY1A, 3 = RLY1B	1 = Closes RLY1A/RLY1B
		RLY 2	J8, 4-6	4 = 5 = RLY2A, 6 = RLY2B	1 = Closes RLY2A/RLY2B
		RLY 3	J8, 7-9	7 = 8 = RLY3A, 9 = RLY3B	1 = Closes RLY3A/RLY3B
<b>MLV</b>	Minimum load valve	RLY 6	J8, 16-18	16 = 17 = RLY6A, 18 = RLY6B	1 = Closes RLY6A/RLY6B



**Fig. 28 — Staged Gas Heat Control Board (SCB)**

**Table 118 — Staged Gas Control Board (SCB) Inputs and Outputs**

POINT NAME	POINT DESCRIPTION	I/O POINT NAME	PLUG AND PIN REFERENCE	SIGNAL PIN(S)	PORT STATE
<b>INPUTS</b>					
		AN1	J5, 1-3	1=5v, 2=Vin, 3=GND (thermistor 1-2)	(0-5VDC, thermistor, ohms)
		AN2	J5, 4-6	4=5v, 5=Vin, 6=GND (thermistor 4-5)	(0-5VDC, thermistor, ohms)
<b>LAT1SGAS</b>	Leaving air temperature 1	AN3	J5, 7-9	7=5v, 8=Vin, 9=GND (thermistor 7-8)	(0-5VDC, thermistor, ohms)
<b>LAT2SGAS</b>	Leaving air temperature 2	AN4	J5, 10-12	10=5v, 11=Vin, 12=GND (thermistor 10-11)	(0-5VDC, thermistor, ohms)
<b>LAT3SGAS</b>	Leaving air temperature 3	AN5	J5, 13-15	13=5v, 14=Vin, 15=GND (thermistor 13-14)	(0-5VDC, thermistor, ohms)
		AN6	J6, 1-3	1=5v, 2=Vin, 3=GND (thermistor 1-2)	(0-5VDC, thermistor, ohms)
		AN7	J6, 4-6	4=5v, 5=Vin, 6=GND (thermistor 4-5)	(0-5VDC, thermistor, ohms)
		AN8	J6, 7-9	7=5v, 8=Vin, 9=GND (thermistor 7-8)	(0-5VDC, thermistor, ohms)
		AN9	J7, 1-2	1	(thermistor, ohms)
		AN10	J7, 3-4	3	(thermistor, ohms)
<b>OUTPUTS</b>					
		AO1	J8, 1-2	1=0-20mA, 2=GND	0-20mA OUT
		AO2	J8, 3-4	3=0-20mA, 4=GND	0-20mA OUT
<b>HS3</b>	Heat Stage 3	RLY1	J9, 1-3	1 = 2 = RLY1A, 3 = RLY1B	1 = Closes RLY1A/RLY1B
<b>HS4</b>	Heat Stage 4	RLY 2	J9, 4-6	4 = 5 = RLY2A, 6 = RLY2B	1 = Closes RLY2A/RLY2B
<b>HS5</b>	Heat Stage 5	RLY 3	J9, 7-9	7 = 8 = RLY3A, 9 = RLY3B	1 = Closes RLY3A/RLY3B
<b>HS6</b>	Heat Stage 6	RLY 4	J9, 10-12	10 = 11 = RLY4A, 12 = RLY4B	1 = Closes RLY4A/RLY4B
		RLY 5	J9, 13-15	13 = 14 = RLY5A, 15 = RLY5B	1 = Closes RLY5A/RLY5B



**Fig. 29 — Controls Expansion Board (CEM)**

**Table 119 — Controls Expansion Board (CEM) Inputs**

POINT NAME	POINT DESCRIPTION	I/O POINT NAME	PLUG AND PIN REFERENCE	SIGNAL PIN(S)	PORT STATE
<b>INPUTS</b>					
SFS	Supply Fan Status switch	DI 1	J7, 1-2	2	0 = 24vac, 1= 0vac
DMD_SW1	Demand Limit - SW1	DI 2	J7, 3-4	4	0 = 24vac, 1= 0vac
DMD_SW2/ DHD ISGIN	Demand Limit - SW2/ Dehumidification Switch Input	DI 3	J7, 5-6	6	0 = 24vac, 1= 0vac
PRES	Pressurization	DI 4	J7, 7-8	8	0 = 24vac, 1= 0vac
EVAC	Evacuation	DI 5	J7, 9-10	10	0 = 24vac, 1= 0vac
PURG	Purge	DI 6	J7, 11-12	12	0 = 24vac, 1= 0vac
IAQIN	Indoor Air Quality Switch	DI 7	J7, 13-14	14	0 = 24vac, 1= 0vac
		AN7	J6, 1-3	2 (1 = loop power)	(0-20mA input)
DMDLMTMA	4-20mA Demand Limit	AN8	J6, 4-6	5 (4 = loop power)	(0-20mA input)
EDTRESMA	4-20mA Evaporator Discharge SP Reset	AN9	J6, 7-9	8 (7 = loop power)	(0-20mA input)
OAQ	Outside Air CO <sub>2</sub> Sensor	AN10	J6, 10-12	11 (10 = loop power)	(0-20mA input)
SPRESET	SP Reset milliamps	AN10	J6, 10-12	11 (10 = loop power)	(0-20mA input)
CEM_10K1/ CEM_4201	CEM AN1 10k temp J5,1-2/ CEM AN1 4-20 ma J5,1-2	AN1	J5, 1-2	1	(thermistor, ohms)
CEM_10K2/ CEM_4202	CEM AN2 10k temp J5,3-4/ CEM AN2 4-20 ma J5,3-4	AN2	J5, 3-4	3	(thermistor, ohms)
CEM_10K3/ CEM_4203	CEM AN3 10k temp J5,5-6/ CEM AN3 4-20 ma J5,5-6	AN3	J5, 5-6	5	(thermistor, ohms)
CEM_10K4/ CEM_4204	CEM AN4 10k temp J5,7-8/ CEM AN4 4-20 ma J5,7-8	AN4	J5, 7-8	7	(thermistor, ohms)
		AN5	J5, 9-10	9	(thermistor, ohms)
		AN6	J5, 11-12	11	(thermistor, ohms)

**Table 120 — IGC Board Inputs and Outputs**

POINT NAME	POINT DESCRIPTION	CONNECTOR PIN NO.
<b>INPUTS</b>		
RT	24 Volt Power Supply	R1,C
W	Heat Demand	2
G	Fan	3
LS	Limit Switch	7,8
RS	Rollout Switch	5,6
SS	Hall Effect Sensor	1,2,3
CS	Centrifugal Switch (Not Used)	9,10
FS	Flame Sense	FS
<b>OUTPUTS</b>		
CM	Induced Draft Motor	CM
IFO	Indoor Fan	IFO
R	24 Volt Power Output (Not Used)	R
SPARK	Sparker	—
LED	Display LED	

**SCROLLING MARQUEE** — This device is the keypad interface used to access the control information, read sensor values, and test the unit. The scrolling marquee display is a 4-key, 4-character, 16-segment LED display as well as an Alarm Status LED. See Fig. 30. The display is easy to operate using 4 buttons and a group of 11 LEDs that indicate the following menu structures:

- Run Status
- Service Test
- Temperatures
- Pressures
- Set points
- Inputs
- Outputs
- Configuration
- Timeclock
- Operating Modes
- Alarms

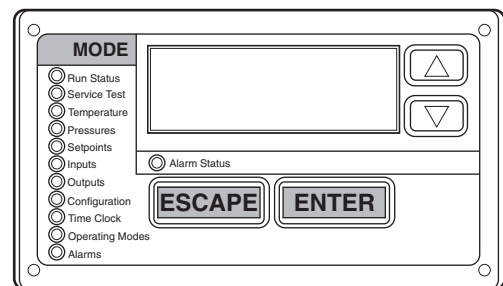
Through the scrolling marquee the user can access all the inputs and outputs to check on their values and status. Because the unit is equipped with suction pressure transducers and discharge saturation temperature sensors it can also display

pressures typically obtained from gages. The control includes a full alarm history, which can be accessed from the display. In addition, through the scrolling marquee the user can access a built-in test routine that can be used at start-up commission and to diagnose operational problems with the unit. The scrolling marquee is located in the main control box and is standard on all units.

**SUPPLY FAN** — The size 020 to 050 units are equipped with two 15 x 11-in. forward-curved fans. The size 051 and 060 units have three 15 x 11-in. fans. They are on a common shaft and are driven by single belt drive 3-phase motor. The fan is controlled directly by the *ComfortLink* controls.

**VARIABLE FREQUENCY DRIVE (VFD)** — On variable volume units, the supply fan speed is controlled by a 3-phase VFD. The VFD is located in the fan section behind a removable panel as shown in Fig. 24 and 25. The VFD speed is controlled directly by the *ComfortLink* controls through a 4 to 20 mA signal based on a supply duct pressure sensor. The inverter has a display, which can be used for service diagnostics, but setup of the supply duct pressure set point and control loop factors is done through the scrolling marquee display. The VFD is powered during normal operation to prevent condensation from forming on the boards during the off mode and is stopped by driving the speed to 0 (by sending a 2 mA signal to the VFD).

The A Series units use ABB ACH550 VFDs. The interface wiring for the VFDs is shown in Fig. 31. Terminal designations are shown in Table 121.



**Fig. 30 — Scrolling Marquee**



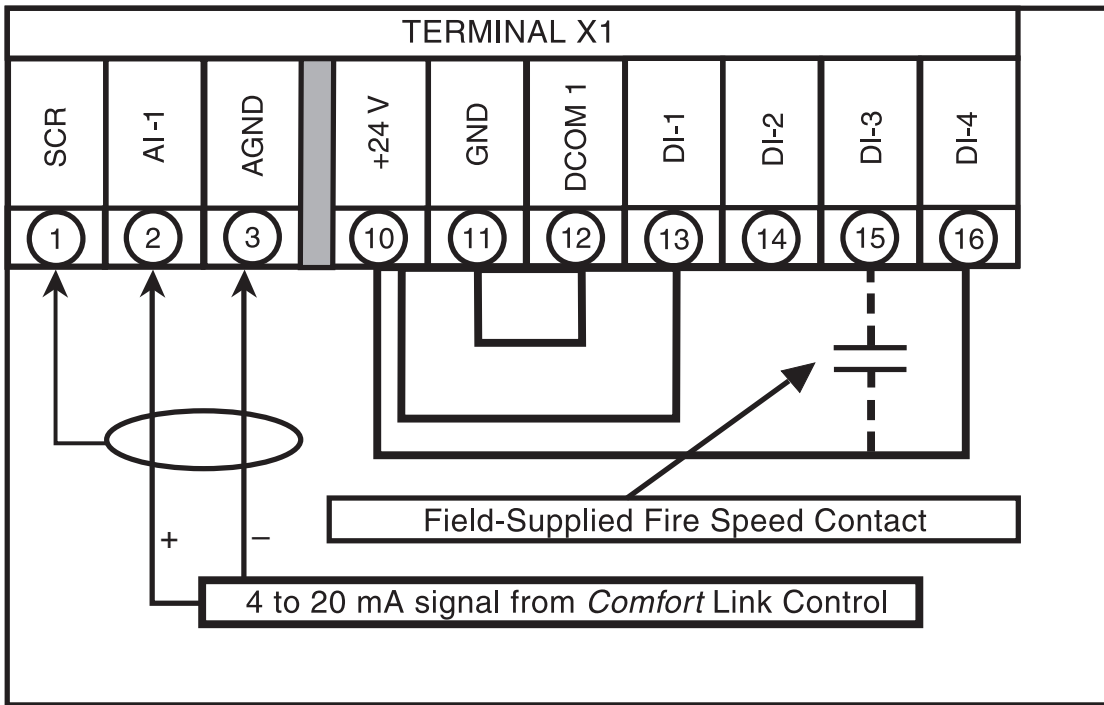


Fig. 31 — VFD Wiring

Table 121 — VFD Terminal Designations

TERMINAL	FUNCTION
U1 V1 W1	Three-Phase Main Circuit Input Power Supply
U2 V2 W2	Three-Phase AC Output to Motor, 0 V to Maximum Input Voltage Level
X1-11 (GND) X1-12 (COMMON)	Factory-supplied jumper
X1-10 (24 VDC) X1-13 (DI-1)	Run (factory-supplied jumper)
X1-10 (24 VDC) X1-16 (DI-4)	Start Enable 1 (factory-supplied jumper). When opened the drive goes to emergency stop.
X1-2 (AI-1) X1-3 (AGND)	Factory wired for 4 to 20 mA remote input

**POWER EXHAUST** — The units can be equipped with an optional power exhaust system. The power exhaust fans are forward-curved fans with direct-drive motors. The motors are controlled directly by the *ComfortLink* controls through the ECB1 board. On the 48/50A020-050 units there are 4 fans. On the 48/50A051 and 060 units there are 6 fans. The fan sequences are controlled to provide 4 stages on the 48/50A020-050 units and 6 stages on the 48/50A051 and 060 units. There are two control methods. For CV applications the fans can be configured for 2 stages based on adjustable economizer damper positions. For VAV applications and CV units with the building pressure control option, the fans are sequenced to maintain a building pressure set point based on a building pressure transducer.

**ECONOMIZER MOTOR** — The economizer outside air and return air dampers are gear-driven dampers without linkage. A digitally controlled economizer motor controls their position. The motor position is controlled by the ECB1 board by means of a digital two-way communication signal. This allows for

accurate control of the motors as well as feedback information and diagnostics information. The control has a self-calibration routine that allows the motor position to be configured at initial unit start-up. The motor is located on the economizer and can be reached through the filter access door.

**THERMISTORS AND PRESSURE TRANSDUCERS** — The 48/50AJ,AK,AW,AY units are equipped with thermistors and pressure transducers. These units have two thermistors connected to the condenser coil and two pressure transducers that are connected to the low side of the system.

The 48/50A2,A3,A4,A5 units are equipped with four pressure transducers. These units have two pressure transducers connected to the low side of the system and two pressure transducers connected to the high side of the system.

By using either temperature sensors or transducers, the *ComfortLink* controller displays the high and low side pressures and saturation temperatures. A normal gage set is not required.

**SMOKE DETECTOR** — The units can be equipped with an optional smoke detector located in the return air. The detector is wired to the *ComfortLink* controls and, if activated, will stop the unit by means of a special fire mode. The smoke detector can also be wired to an external alarm system through TB5 terminals 10 and 11. The sensor is located in the return air section behind the filter access door.

**FILTER STATUS SWITCH** — The units can be equipped with an optional filter status switch. The switch measures the pressure drop across the filters and closes when an adjustable pressure set point is exceeded. The sensor is located in the return air section behind the filter access door.

**RETURN AIR CO<sub>2</sub> SENSOR** — The unit can also be equipped with a return air IAQ CO<sub>2</sub> sensor that is used for the demand control ventilation. The sensor is located in the return air section and can be accessed from the filter access door.



**BOARD ADDRESSES** — Each board in the system has an address. The MBB has a default address of 1 but it does have an instance jumper that should be set to 1 as shown in Fig. 26. For the other boards in the system there is a 4-dip switch header on each board that should be set as shown below.

BOARD	SW1	SW2	SW3	SW4
ECB1	0	0	0	0
ECB2	1	0	0	0
SCB	0	0	0	0
CEM	0	0	0	0

0 = On; 1 = Off

**FIELD CONNECTION TERMINAL STRIPS** — Field connection terminal strips are located in the main control box. See Fig. 32 and Table 122.

**Accessory Control Components** — In addition to the factory-installed options, the units can also be equipped with several field-installed accessories that expand the control features of the unit. The following hardware components can be used as accessories.

**ROOM THERMOSTATS (48/50AJ,AW,A2,A4 UNITS ONLY)** — The *ComfortLink* controls support a conventional electro-mechanical or electronic thermostat that uses the Y1, Y2, W1, W2, and G signals. The control also supports an additional input for an occupied/unoccupied command that is available on some new thermostats. The *ComfortLink* controls can be configured to run with multiple stages of capacity which allows up to 6 stages of capacity. Although the unit can be configured for normal 2-stage control, it is recommended that the multi-stage control be used. The room thermostat is connected to TB4.

**SPACE SENSOR** — The *ComfortLink* controls support the use of space temperature sensors. The T55 and T56 sensors and CCN communicating T58 room sensor can be used. The T55 and T56 sensors are connected to TB5 terminal 3, 4, and 5. The T58 sensor is connected to the CCN connections on TB3. When a T55, T56, or T58 sensor is used, the user must install the red jumpers from R to W1, and W2 on TB4 for the heat function to work correctly.

**SPACE CO<sub>2</sub> SENSORS** — The *ComfortLink* controls also support a CO<sub>2</sub> IAQ sensor that can be located in the space for use in demand ventilation. The sensor must be a 4 to 20 mA sensor and should be connected to TB5 terminal 6 and 7. See Fig. 33 for sensor wiring.

**ECONOMIZER HUMIDITY CHANGEOVER SENSORS** — The *ComfortLink* controls support 5 different changeover schemes for the economizer. These are:

- outdoor air dry bulb
- differential dry bulb

- outdoor air enthalpy curves
- differential enthalpy
- custom curves (a combination of an enthalpy/dewpoint curve and a dry bulb curve).

The units are equipped as standard with an outside air and return air dry bulb sensor which supports the dry bulb changeover methods. If the other methods are to be used, then a field-installed humidity sensor must be installed for outdoor air enthalpy and customer curve control and two humidity sensors must be installed for differential enthalpy. Installation holes are pre-drilled and wire harnesses are installed in every unit for connection of the humidity sensors. The *ComfortLink* controls convert the measured humidity into enthalpy, dewpoint, and the humidity changeover curves.

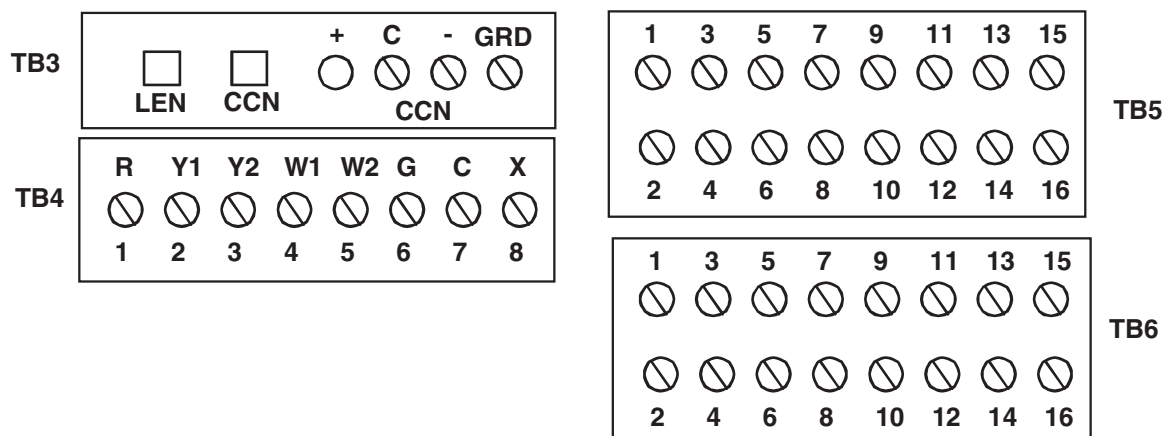
**MOTORMASTER® V CONTROL** — For operation below 32 F when an economizer is not used, the units can be equipped with an accessory Motormaster V control, which controls the speed of the stage 1 condenser fans. The Motormaster V control is a 3-phase inverter that controls the speed of the fans based on a pressure transducer connected to the liquid line. On 48/50A020-035 units, one fan will be controlled. On 48/50A036-060 units, two fans will be controlled. For units equipped with an economizer, there should not be a need for this control because the economizer can provide free cooling using outside air, which will be significantly lower in operating cost.

The accessory Motormaster V speed control is a completely self-contained control and is not controlled by the unit's *ComfortLink* controller. On 48/50A051 and 060 units with 6 fan motors, the Motormaster control configuration (*M.M.*) must be set to YES. See page 39.

**ACCESSORY NAVIGATOR™ DISPLAY** — The accessory handheld Navigator display can be used with the 48/50A series units. See Fig. 34. The Navigator display operates the same way as the scrolling marquee device. The ECB1 and ECB2 boards contain a second LEN port (J3 connection) than can be used with the handheld Navigator display.

**CONTROL MODULE COMMUNICATIONS**

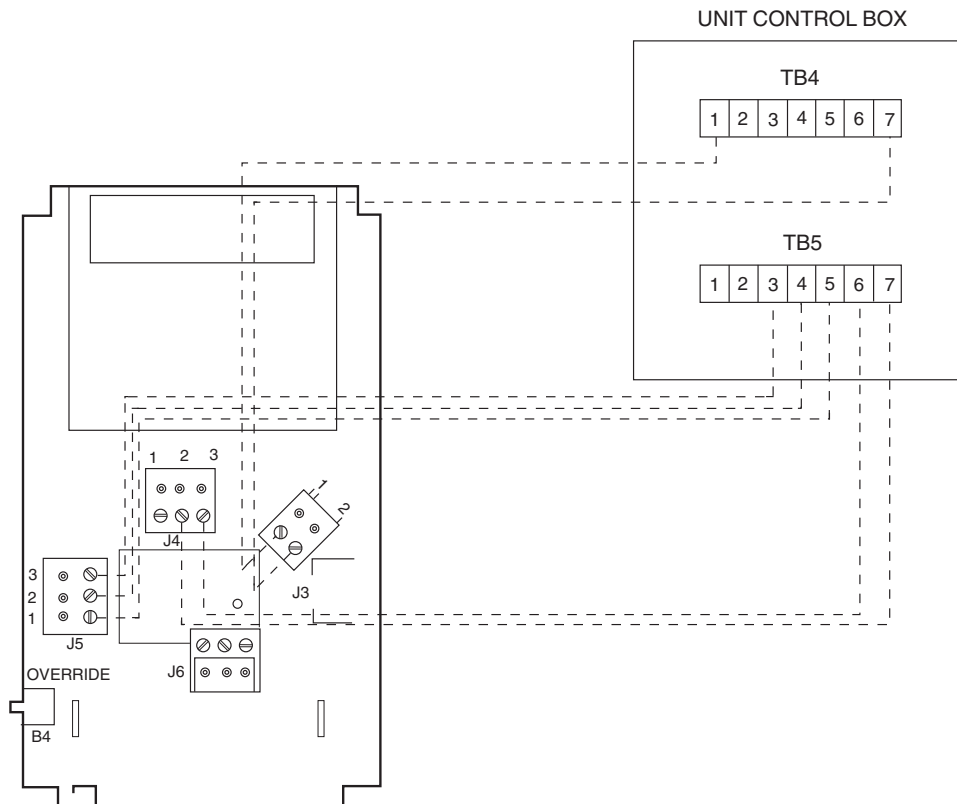
**Red LED** — Proper operation of the control boards can be visually checked by looking at the red status LEDs as shown on Fig. 26-29. When operating correctly, the red status LEDs should blink in unison at a rate of once every 2 seconds. If the red LEDs are not blinking in unison, verify that correct power is being supplied to all modules. Also, be sure that the main base board is supplied with the current software. If necessary, reload current software. If the problem still persists, replace the MBB. A board LED that is lit continuously or blinking at a rate of once per second or faster indicates that the board should be replaced.



**Fig. 32 — Field Connection Terminal Strips (Main Control Box)**

**Table 122 — Field Connection Terminal Strips**

TERMINAL BOARD	TERMINAL NO.	DESCRIPTION	TYPE
<b>TB-1 - POWER CONNECTION OR DISCONNECT (in Main Control Box)</b>			
TB1	11	L1 power supply	208-230/460/575/380/-3-60, 400-3-50
	12	L2 power supply	208-230/460/575/380/-3-60, 400-3-50
	13	L3 power supply	208-230/460/575/380/-3-60, 400-3-50
<b>TB-2 - GROUND (in Main Control Box)</b>			
TB2	1	Neutral Power	
<b>TB-3 - CCN COMMUNICATIONS (HY84HA096) (in Main Control Box)</b>			
TB3	1	LEN +	5 VDC, logic
	2	LEN C	5 VDC, logic
	3	LEN -	5 VDC, logic
	4	24 VAC	24 VAC
	5	CCN +	5 VDC, logic
	6	CCN c	5 VDC, logic
	7	CCN -	5 VDC, logic
	8	Grd	ground
<b>TB-4 - THEROMSTAT CONNECTIONS (HY84HA090) (in Main Control Box)</b>			
TB4	1	Thermostat R	24VAC
	2	Thermostat Y1	24VAC
	3	Thermostat Y2	24VAC
	4	Thermostat W1	24VAC
	5	Thermostat W2	24VAC
	6	Thermostat G	24VAC
	7	Thermostat C	24VAC
	8	Thermostat X	24VAC
<b>TB-5 - FIELD CONNECTIONS (HY84HA101) (in Main Control Box)</b>			
TB5	1	VAV Heater Interlock Relay, Ground	external 24 VDC relay
	2	VAV Heater Interlock Relay, 24 VAC	external 24 VDC relay
	3	T56 Sensor	5VDC
	4	T56/T58 Ground	5VDC
	5	T58 Setpoint	5VDC
	6	Indoor Air IAQ Remote Sensor/Remote Pot/Remote 4-20 mA	4-20 mA, ext. powered w/res or 0-5 VDC
	7	Indoor Air IAQ Remote Sensor/Remote Pot/Remote 4-20 mA	4-20 mA, ext. powered w/res or 0-5 VDC
	8	Smoke Detector Remote Alarm	external contacts
	9	Smoke Detector Remote Alarm	external contacts
	10	Fire Shutdown	24 VAC external
	11	Fire Shutdown	external contact
	12	Fire Control Common	external contact
	13	Fire Pressurization	external contact
	14	Fire Evacuation	external contact
	15	Fire Smoke Purge	external contact
	16	Not Used	—
<b>TB-6 - FIELD CONNECTIONS (HY84HA101) (in Main Control Box)</b>			
TB6	1	Remote Occupied/Economizer Enable 24 VAC	external 24 VAC contact
	2	Remote Economizer Contact	external 24 VAC contact
	3	Remote Occupied Contact	external 24 VAC contact
	4	Demand Limit Contacts Common	external 24 VAC contact
	5	Demand Limit Switch 1	external 24 VAC contact
	6	Demand Limit Switch 2/Dehumidify Switch Input	external 24 VAC contact
	7	Demand Limit 4-20 mA	externally powered 4-20 mA
	8	Demand Limit 4-20 mA	externally powered 4-20 mA
	9	Remote Supply Air Setpoint 4-20 mA	externally powered 4-20 mA
	10	Remote Supply Air Setpoint 4-20 mA	externally powered 4-20 mA
	11	Outdoor Air IAQ 4-20 mA	externally powered 4-20 mA
	12	Outdoor Air IAQ 4-20 mA	externally powered 4-20 mA
	13	IAQ Remote Switch	external contact
	14	IAQ Remote Switch	external contact
	15	Supply Fan Status Switch	—
	16	Supply Fan Status Switch	—
<b>TB-7 - ELECTRIC HEAT POWER BLOCK (in Electric Heat section)</b>			
TB7	1	L1 Power Supply	208-230/460/575/380/-3-60, 400-3-50
	2	L2 Power Supply	208-230/460/575/380/-3-60, 400-3-50
	3	L3 Power Supply	208-230/460/575/380/-3-60, 400-3-50



**Fig. 33 — CO<sub>2</sub> and Space Temperature Sensor Wiring (33ZCT55CO2 and 33ZCT56CO2)**

**Green LED** — The boards also have a green LED, which is the indicator of the operation of the LEN communications, which is used for communications between the boards. On the MBB board the Local Equipment Network (LEN) LED should always be blinking whenever power is on. All other boards have a LEN LED that will blink whenever power is on and there is communication occurring. If LEN LED is not blinking, check LEN connections for potential communication errors (J3 and J4 connectors). A 3-wire sensor bus accomplishes communication between modules. These 3 wires run in parallel from module to module.

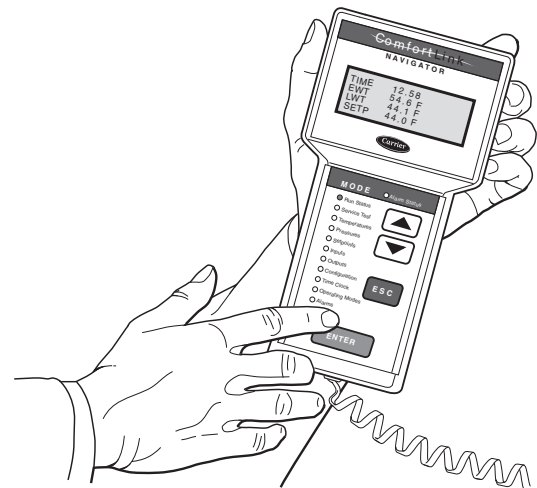
**Yellow LED** — The MBB has one yellow LED. The Carrier Comfort Network® (CCN) LED will blink during times of network communication. The other boards do not have a CCN communications port.

**CARRIER COMFORT NETWORK INTERFACE** — The 48/50A Series units can be connected to the CCN interface if desired. The communication bus wiring is a shielded, 3-conductor cable with drain wire and is field supplied and installed. See the Installation Instructions for wiring information. The system elements are connected to the communication bus in a daisy chain arrangement. The positive pin of each system element communication connector must be wired to the positive pins of the system elements on either side of it. This is also required for the negative and signal ground pins of each system element. Wiring connections for CCN should be made at TB3. See Fig. 35. Consult the CCN Contractor's Manual for further information.

**NOTE:** Conductors and drain wire must be 20-AWG (American Wire Gage) minimum stranded, tinned copper. Individual conductors must be insulated with PVC, PVC/nylon, vinyl, Teflon, or polyethylene. An aluminum/polyester 100% foil shield and an outer jacket of PVC, PVC/nylon, chrome vinyl, or Teflon with a minimum operating temperature range of -20 C to 60 C is required.

It is important when connecting to a CCN communication bus that a color-coding scheme be used for the entire network to simplify the installation. It is recommended that red be used for the signal positive, black for the signal negative and white for the signal ground. Use a similar scheme for cables containing different colored wires.

At each system element, the shields of its communication bus cables must be tied together. If the communication bus is entirely within one building, the resulting continuous shield must be connected to a ground at one point only. If the communication bus cable exits from one building and enters another, the shields must be connected to grounds at the lightning suppressor in each building where the cable enters or exits the building (one point per building only).



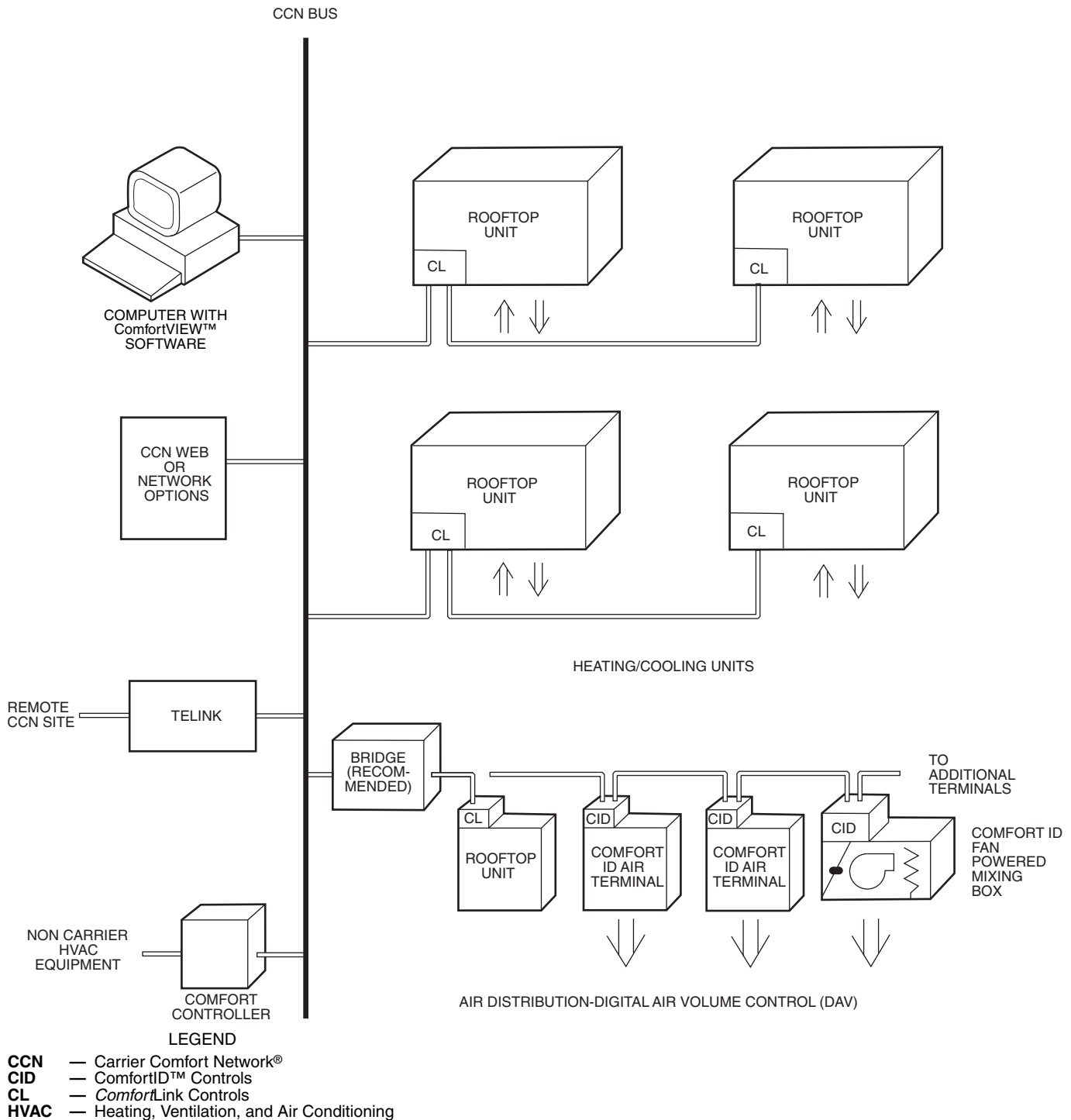
**Fig. 34 — Accessory Navigator Display**

To connect the unit to the network:

1. Turn off power to the control box.
2. Cut the CCN wire and strip the ends of the red (+), white (ground), and black (-) conductors. (Substitute appropriate colors for different colored cables.)
3. Connect the red wire to (+) terminal on TB3 of the plug, the white wire to COM terminal, and the black wire to the (-) terminal.
4. The RJ14 CCN connector on TB3 can also be used, but is only intended for temporary connection (for example, a laptop computer running Service Tool).

5. Restore power to unit.

**IMPORTANT:** A shorted CCN bus cable will prevent some routines from running and may prevent the unit from starting. If abnormal conditions occur, unplug the connector. If conditions return to normal, check the CCN connector and cable. Run new cable if necessary. A short in one section of the bus can cause problems with all system elements on the bus.



**Fig. 35 — CCN System Architecture**

## SERVICE

### ⚠ WARNING

Before performing service or maintenance operations on unit, turn off main power switch to unit. Electrical shock could cause personal injury.

**Service Access** — All unit components can be reached through clearly labelled hinged access doors. These doors are not equipped with tiebacks, so if heavy duty servicing is needed, either remove them or prop them open to prevent accidental closure.

Each door is held closed with 3 latches. The latches are secured to the unit with a single  $\frac{1}{4}$ -in. - 20 x  $\frac{1}{2}$ -in. long bolt. See Fig. 36.

To open, loosen the latch bolt using a  $\frac{7}{16}$ -in. wrench. Pivot the latch so it is not in contact with the door. Open the door. To shut, reverse the above procedure.

NOTE: Disassembly of the top cover may be required under special service circumstances. It is very important that the orientation and position of the top cover be marked on the unit prior to disassembly. This will allow proper replacement of the top cover onto the unit and prevent rainwater from leaking into the unit.

IMPORTANT: After servicing is completed, make sure door is closed and relatched properly, and that the latches are tight. Failure to do so can result in water leakage into the evaporator section of the unit.

**Cleaning** — Inspect unit interior at beginning of each heating and cooling season and as operating conditions require. Remove unit side panels and/or open doors for access to unit interior.

**MAIN BURNERS** — At the beginning of each heating season, inspect for deterioration or blockage due to corrosion or other causes. Observe the main burner flames and adjust if necessary. Check spark gap. See Fig. 37. Refer to Main Burners section on page 140.

**FLUE GAS PASSAGEWAYS** — The flue collector box and heat exchanger cells may be inspected by removing gas section access panel, flue box cover, collector box, and main burner assembly (Fig. 38 and 39). Refer to Main Burners section on page 140 for burner removal sequence. If cleaning is required, clean all parts with a wire brush. Reassemble using new high-temperature insulation for sealing.

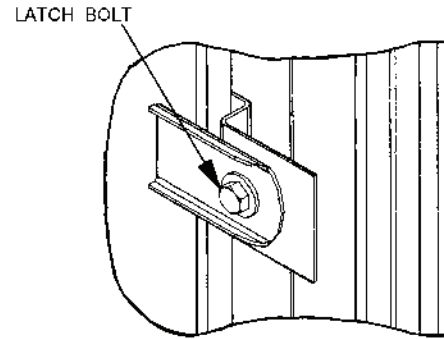


Fig. 36 — Door Latch

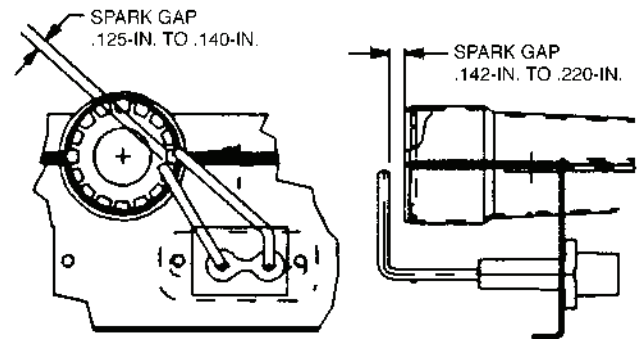
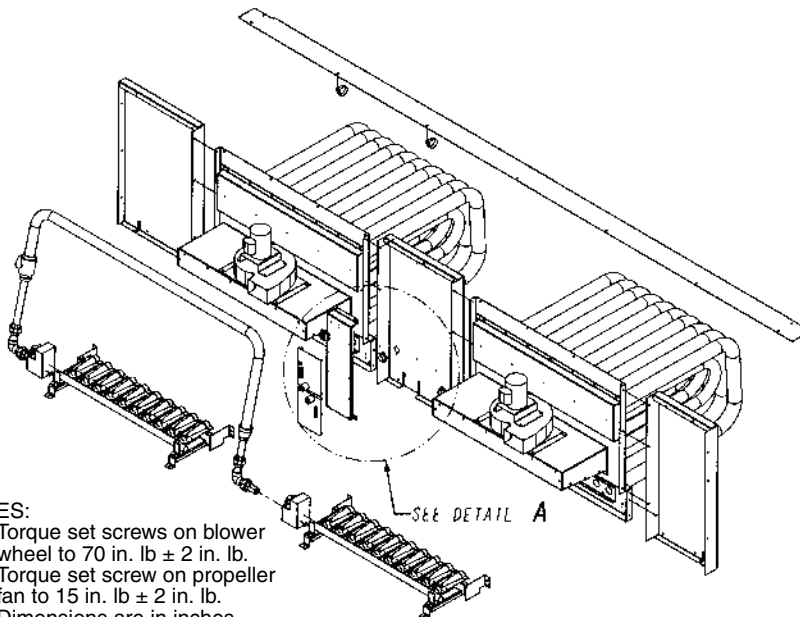


Fig. 37 — Spark Gap Adjustment



NOTES:

1. Torque set screws on blower wheel to 70 in. lb  $\pm$  2 in. lb.
2. Torque set screw on propeller fan to 15 in. lb  $\pm$  2 in. lb.
3. Dimensions are in inches.

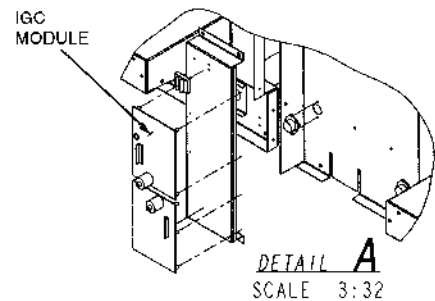
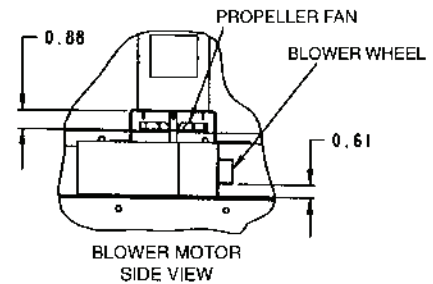
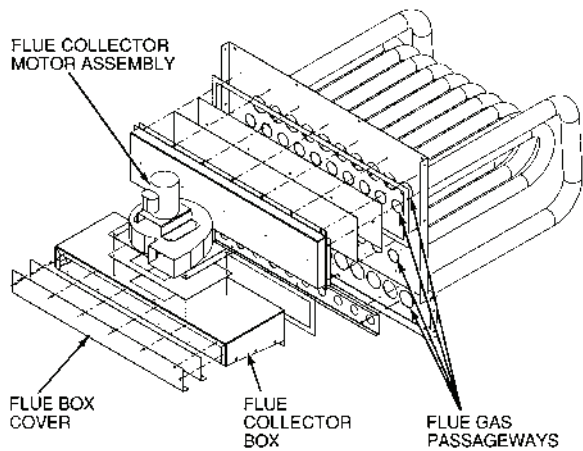


Fig. 38 — Typical Gas Heating Section





**Fig. 39 — Gas Heat Section Details**

**COMBUSTION-AIR BLOWER** — Clean periodically to assure proper airflow and heating efficiency. Inspect blower wheel every fall and periodically during heating season. For the first heating season, inspect blower wheel bi-monthly to determine proper cleaning frequency.

To inspect blower wheel, remove heat exchanger access panel. Shine a flashlight into opening to inspect wheel. If cleaning is required, remove motor and wheel assembly by removing screws holding motor mounting plate to top of combustion fan housing (Fig. 38 and 39). The motor, scroll, and wheel assembly can be removed from the unit. Remove scroll from plate. Remove the blower wheel from the motor shaft and clean with a detergent or solvent. Replace motor and wheel assembly.

**ROUND TUBE PLATE FIN COIL MAINTENANCE AND CLEANING RECOMMENDATIONS** — Routine cleaning of coil surfaces is essential to maintain proper operation of the unit. Elimination of contamination and removal of harmful residues will greatly increase the life of the coil and extend the life of the unit. The following maintenance and cleaning procedures are recommended as part of the routine maintenance activities to extend the life of the coil.

**Remove Surface Loaded Fibers** — Surface loaded fibers or dirt should be removed with a vacuum cleaner. If a vacuum cleaner is not available, a soft non-metallic bristle brush may be used. In either case, the tool should be applied in the direction of the fins. Coil surfaces can be easily damaged (fin edges can be easily bent over and damage to the coating of a protected coil) if the tool is applied across the fins.

**NOTE:** Use of a water stream, such as a garden hose, against a surface loaded coil will drive the fibers and dirt into the coil. This will make cleaning efforts more difficult. Surface loaded fibers must be completely removed prior to using low velocity clean water rinse.

**Periodic Clean Water Rinse** — A periodic clean water rinse is very beneficial for coils that are applied in coastal or industrial environments. However, it is very important that the water rinse is made with very low velocity water stream to avoid damaging the fin edges. Monthly cleaning as described below is recommended.

**Routine Cleaning of Coil Surfaces** — Monthly cleaning with Totaline® environmentally sound coil cleaner is essential to extend the life of coils. This cleaner is available from Carrier Replacement parts division as part number P902-0301 for a one gallon container, and part number P902-0305 for a 5 gallon container. It is recommended that all coils, including copper tube aluminum fin, pre-coated fin, copper fin, or E-coated coils be cleaned with the Totaline environmentally sound coil cleaner as described below. Coil cleaning should be part of the unit's regularly scheduled maintenance procedures to ensure long life

of the coil. Failure to clean the coils may result in reduced durability in the environment.

Avoid the use of:

- coil brighteners
- acid cleaning prior to painting
- high pressure washers
- poor quality water for cleaning

Totaline environmentally sound coil cleaner is non-flammable, hypoallergenic, nonbacterial, and a USDA accepted biodegradable agent that will not harm the coil or surrounding components such as electrical wiring, painted metal surfaces, or insulation. Use of non-recommended coil cleaners is strongly discouraged since coil and unit durability could be affected.

*Totaline Environmentally Sound Coil Cleaner Application Equipment*

- 2½ gallon garden sprayer
- water rinse with low velocity spray nozzle

**CAUTION**

Harsh chemicals, household bleach or acid or basic cleaners should not be used to clean outdoor or indoor coils of any kind. These cleaners can be very difficult to rinse out of the coil and can accelerate corrosion at the fin/tube interface where dissimilar materials are in contact. If there is dirt below the surface of the coil, use the Totaline environmentally sound coil cleaner as described above.

**CAUTION**

High velocity water from a pressure washer, garden hose, or compressed air should never be used to clean a coil. The force of the water or air jet will bend the fin edges and increase airside pressure drop. Reduced unit performance or nuisance unit shutdown may occur.

*Totaline Environmentally Sound Coil Cleaner Application Instructions*

1. Remove any foreign objects or debris attached to the coil face or trapped within the mounting frame and brackets.
2. Put on personal protective equipment including safety glasses and/or face shield, waterproof clothing and gloves. It is recommended to use full coverage clothing.
3. Remove all surface loaded fibers and dirt with a vacuum cleaner as described above.
4. Thoroughly wet finned surfaces with clean water and a low velocity garden hose, being careful not to bend fins.
5. Mix Totaline environmentally sound coil cleaner in a 2½ gallon garden sprayer according to the instructions included with the cleaner. The optimum solution temperature is 100 F.

**NOTE:** Do NOT USE water in excess of 130 F, as the enzymatic activity will be destroyed.

6. Thoroughly apply Totaline environmentally sound coil cleaner solution to all coil surfaces including finned area, tube sheets and coil headers.
7. Hold garden sprayer nozzle close to finned areas and apply cleaner with a vertical, up-and-down motion. Avoid spraying in horizontal pattern to minimize potential for fin damage.
8. Ensure cleaner thoroughly penetrates deep into finned areas.
9. Interior and exterior finned areas must be thoroughly cleaned.
10. Finned surfaces should remain wet with cleaning solution for 10 minutes.

11. Ensure surfaces are not allowed to dry before rinsing. Reapplying cleaner as needed to ensure 10-minute saturation is achieved.
12. Thoroughly rinse all surfaces with low velocity clean water using downward rinsing motion of water spray nozzle. Protect fins from damage from the spray nozzle.

#### MICROCHANNEL HEAT EXCHANGER (MCHX) CONDENSER COIL MAINTENANCE AND CLEANING RECOMMENDATIONS

#### ⚠ CAUTION

Do not apply any chemical cleaners to MCHX condenser coils. These cleaners can accelerate corrosion and damage the coil.

Routine cleaning of coil surfaces is essential to maintain proper operation of the unit. Elimination of contamination and removal of harmful residues will greatly increase the life of the coil and extend the life of the unit. The following steps should be taken to clean MCHX condenser coils:

1. Remove any foreign objects or debris attached to the coil face or trapped within the mounting frame and brackets.
2. Put on personal protective equipment including safety glasses and/or face shield, waterproof clothing and gloves. It is recommended to use full coverage clothing.
3. Start high pressure water sprayer and purge any soap or industrial cleaners from sprayer before cleaning condenser coils. Only clean potable water is authorized for cleaning condenser coils.
4. Clean condenser face by spraying the coil steady and uniformly from top to bottom while directing the spray straight toward the coil. Do not exceed 900 psig or 30 degree angle. The nozzle must be at least 12 in. from the coil face. Reduce pressure and use caution to prevent damage to air centers.

#### ⚠ CAUTION

Excessive water pressure will fracture the braze between air centers and refrigerant tubes.

**CONDENSATE DRAIN** — Check and clean each year at start of cooling season. In winter, keep drains and traps dry.

**FILTERS** — Clean or replace at start of each heating and cooling season, or more often if operating conditions require. Refer to Installation Instructions for type and size.

**NOTE:** The unit requires industrial grade throwaway filters capable of withstanding face velocities up to 625 fpm.

**OUTDOOR-AIR INLET SCREENS** — Clean screens with steam or hot water and a mild detergent. Do not use disposable filters in place of screens.

#### Lubrication

**FAN SHAFT BEARINGS** — Lubricate bearings at least every 6 months with suitable bearing grease. Do not over grease. Typical lubricants are given below:

MANUFACTURER	LUBRICANT
Texaco	Regal AFB-2*
Mobil	Mobilplex EP No. 1
Sunoco	Prestige 42
Texaco	Multifak 2

\*Preferred lubricant because it contains rust and oxidation inhibitors.

**CONDENSER AND EVAPORATOR-FAN MOTOR BEARINGS** — The condenser and evaporator-fan motors have permanently sealed bearings, so no field lubrication is necessary.

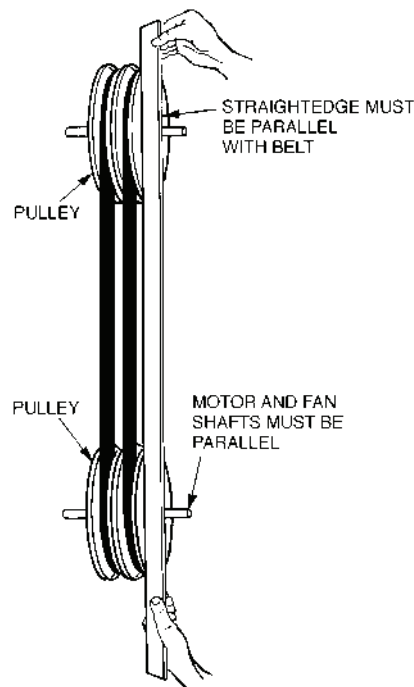
#### Evaporator Fan Performance Adjustment (Fig. 40) — Fan motor pulleys are designed for speed shown in Physical Data table in unit Installation Instructions (factory speed setting).

**IMPORTANT:** Check to ensure that the unit drive matches the duct static pressure using Tables 3-38.

To change fan speeds, change pulleys.

To align fan and motor pulleys:

1. Shut off unit power supply.
2. Loosen fan shaft pulley bushing.
3. Slide fan pulley along fan shaft.
4. Make angular alignment by loosening motor from mounting plate.
5. Retighten pulley.
6. Return power to the unit.

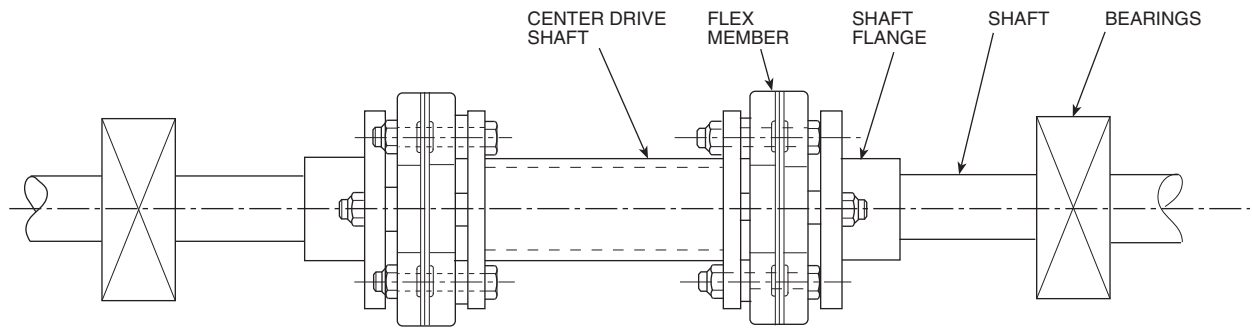


**Fig. 40 — Evaporator-Fan Alignment and Adjustment**

**Evaporator Fan Coupling Assembly** — If the coupling has been removed for other blower assembly component repair or replacement, it is critical that the coupling be reassembled and aligned correctly to prevent premature failures.

**REASSEMBLING THE COUPLING INTO THE UNIT (Fig. 41)**

1. Prior to reassembling the coupling, loosen the 4 bearing mounting bolts, which secure the 2 bearings on either side of the coupling. Remove the drive belts.
2. Reassemble the coupling with the bearings loose. This allows the coupling to find its own self-alignment position.
3. Check the hub-to-shaft fit for close fitting clearances. Replace hubs if high clearances are determined.
4. Check the key for close-fitted clearances on the sides and 0.015 in. clearance over the top of the key. Replace key if necessary.
5. Be sure that hub flanges, flex members, spacer, and hardware are clean and free of oil.
6. Place the flanges onto the shafts with the hub facing outward. Do not tighten the set screws at this time.



**Fig. 41 — Evaporator Fan Coupling**

7. Outside of the unit, assemble the flex members to the center drive shaft with 4 bolts and nuts. The flex members have collars that need to be inserted into the smaller hole of the drive shaft flange.
8. Assemble the flex member/drive shaft assembly to one of the shaft flanges, using 2 bolts and nuts. Slide the other shaft flange towards the assembly and assemble using 2 bolts and nuts. If the shafts are not misaligned, the collar in the flex member should line up with the shaft flange holes.
9. Torque nuts properly to 95 to 100 ft-lb. Do not turn a coupling bolt. Always turn the nut. Always use thread lubricant or anti-seize compound to prevent thread galling.
10. The ends of the shafts should be flush with the inside of the shaft flange. Torque the set screws to 25 ft-lb.
11. After assembly is complete, slowly rotate the shafts by hand for 30 to 60 seconds.
12. Tighten the bearing mounting bolts, using care not to place any loads on the shaft which would cause flexure to the shafts.
13. Reinstall drive belts. (Refer to Belt Tension Adjustment section below.)
14. Visually inspect the assembly. If the shafts are overly misaligned, the drive shaft flange will not be parallel with the shaft flanges.
15. Recheck nut torque after 1 to 2 hours of operation. Bolts tend to relax after being initially torqued.

6. Adjust bolts and nut on mounting plate to secure motor in fixed position. Recheck belt tension after 24 hours of operation. Adjust as necessary. Refer to Installation Instructions for proper tension values.
7. Restore power to unit.

### Evaporator-Fan Motor Replacement

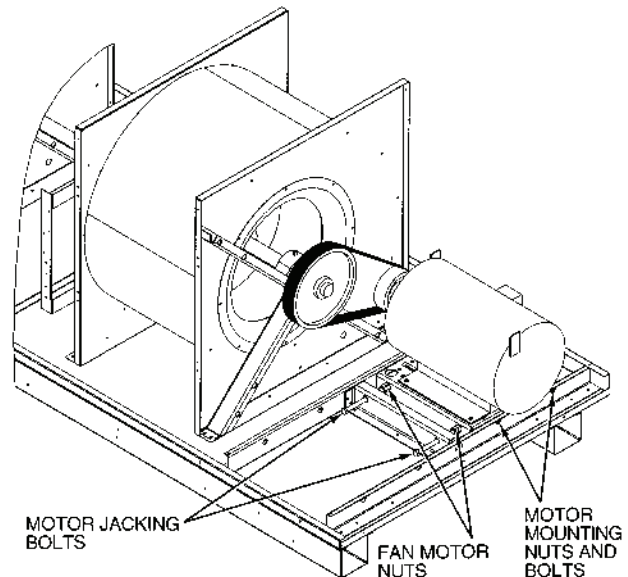
1. Turn off unit power supply.
2. Remove upper outside panel and open hinged door to gain access to motor.
3. Fully retract motor plate adjusting bolts.
4. Loosen the 2 rear (nearest the evaporator coil) motor plate nuts.
5. Remove the 2 front motor plate nuts and carriage bolts.
6. Slide motor plate to the rear (toward the coil) and remove fan belt(s).
7. Slide motor plate to the front and hand tighten one of the rear motor plate nuts (tight enough to prevent the motor plate from sliding back but loose enough to allow the plate to pivot upward).
8. Pivot the front of the motor plate upward enough to allow access to the motor mounting hex bolts and secure in place by inserting a prop.
9. Remove the nuts from the motor mounting hex bolts and remove motor.
10. Replace the locktooth washer under the motor base with a new washer. Be sure that the washer contacts the motor base surface.
11. Reverse above steps to install new motor.

### Evaporator Fan Service and Replacement

1. Turn off unit power supply.
2. Remove supply-air section panels.
3. Remove belt and blower pulley.
4. Loosen setscrews in blower wheels.
5. Remove locking collars from bearings.
6. Remove shaft.
7. Remove venturi on opposite side of bearing.
8. Lift out wheel.
9. Reverse above procedure to reinstall fan.
10. Check and adjust belt tension as necessary.
11. Restore power to unit.

### Belt Tension Adjustment — To adjust belt tension:

1. Turn off unit power supply.
2. Loosen motor mounting nuts and bolts. See Fig. 42.
3. Loosen fan motor nuts.
4. Turn motor jacking bolts to move motor mounting plate left or right for proper belt tension. A slight bow should be present in the belt on the slack side of the drive while running under full load.
5. Tighten nuts.



**Fig. 42 — Belt Tension Adjustment**



## Condenser-Fan Adjustment

NOTE: Condenser fans on size 060 MCHX units are not adjustable.

1. Turn off unit power supply.
2. Remove fan guard.
3. Loosen fan hub setscrews.
4. Adjust fan height on shaft using a straightedge placed across venturi and measure per Fig. 43.
5. Fill hub recess with permagum if rubber hubcap is missing.
6. Tighten setscrews and replace panel(s).
7. Turn on unit power.

**Four-Inch Filter Replacement** — The 4-Inch Filter Change Mode variable is used to service the unit when 4-in. filters are used. When the filters need to be changed, set **Service Test** → **F.4.CH** = **YES**. The unit will be placed in Service Test mode and the economizer will move to the 40% open position to facilitate removal of the 4-in. filters. After the filters have been changed, set **Service Test** → **F.4.CH** = **NO** to return the unit to normal operation.

**Power Failure** — The economizer damper motor is a spring return design. In event of power failure, dampers will return to fully closed position until power is restored.

**Refrigerant Charge** — Amount of refrigerant charge is listed on unit nameplate. Refer to Carrier GTAC II; Module 5; Charging, Recovery, Recycling, and Reclamation section for charging methods and procedures.

Unit panels must be in place when unit is operating during charging procedure.

NOTE: Do not use recycled refrigerant as it may contain contaminants.

**NO CHARGE** — Use standard evacuating techniques. After evacuating system, weigh in the specified amount of refrigerant from the unit nameplate.

### LOW CHARGE COOLING

**All Units with Round Tube-Plate Fin Condenser Coils** — Connect the gage set and a temperature-measuring device to the liquid line. Ensure that all condenser fans are operating. It may be necessary to block part of the coil on cold days to ensure that condensing pressures are high enough to turn on the fans. Adjust the refrigerant charge in each circuit to obtain state point liquid subcooling for specific models as listed in Table 123.

NOTE: Indoor-air cfm must be within normal operating range of unit.

**Table 123 – Round Tube, Plate Fin Unit Charge**

UNIT 48/50	REFRIGERANT TYPE	SIZE	LIQUID SUBCOOLING
AJ,AK,AW,AY	R-22	020, 025, 027, 030, 035, 040, 050, 060	20 F ± 2 F
		036	18 F ± 2 F
		041, 051	15 F ± 2 F
A2,A3,A4,A5	R-410A	020, 027, 040, 050, 060	15 F ± 2 F
		030, 035	20 F ± 2 F
		025	12 F ± 2 F

**48/50A2,A3,A4,A5 Units with MCHX Condenser** — Due to the compact, all aluminum design, microchannel heat exchangers will reduce refrigerant charge and overall operating weight. As a result, charging procedures for MCHX units require more accurate measurement techniques. Charge should be added in small increments. Using cooling charging charts provided (Fig. 44-50), add or remove refrigerant until conditions of the chart are met. As conditions get close to the point

on the chart, add or remove charge in 1/4 lb increments until complete. Ensure that all fans are on and all compressors are running when using charging charts.

**To Use the Cooling Charging Chart** — Use the outdoor air temperature, saturated suction temperature and saturated condensing temperature (available on the *ComfortLink* display), and find the intersection point on the cooling charging chart. If intersection point is above the line, carefully recover some of the refrigerant. If intersection point is below the line, carefully add refrigerant.

NOTE: Indoor-air cfm must be within normal operating range of unit.

**Thermostatic Expansion Valve (TXV)** — Each circuit has a TXV. The TXV is adjustable and is factory set to maintain 8 to 12° F superheat leaving the evaporator coil. The TXV controls flow of liquid refrigerant to the evaporator coils. Adjusting the TXV is not recommended.

## Gas Valve Adjustment

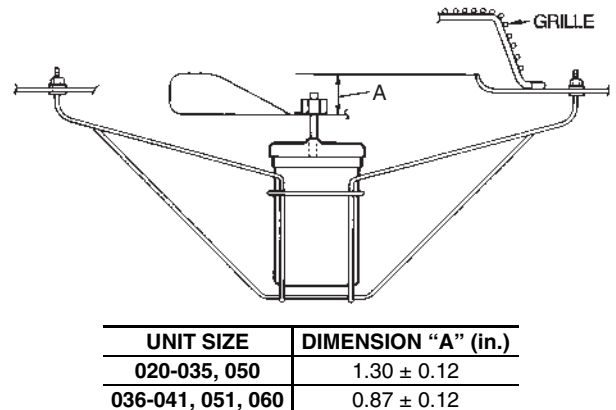
**NATURAL GAS** — The 2-stage gas valve opens and closes in response to the thermostat or limit control.

When power is supplied to valve terminals 3 and 4, the pilot valve opens to the preset position. When power is supplied to terminals 1 and 2, the main valve opens to its preset position.

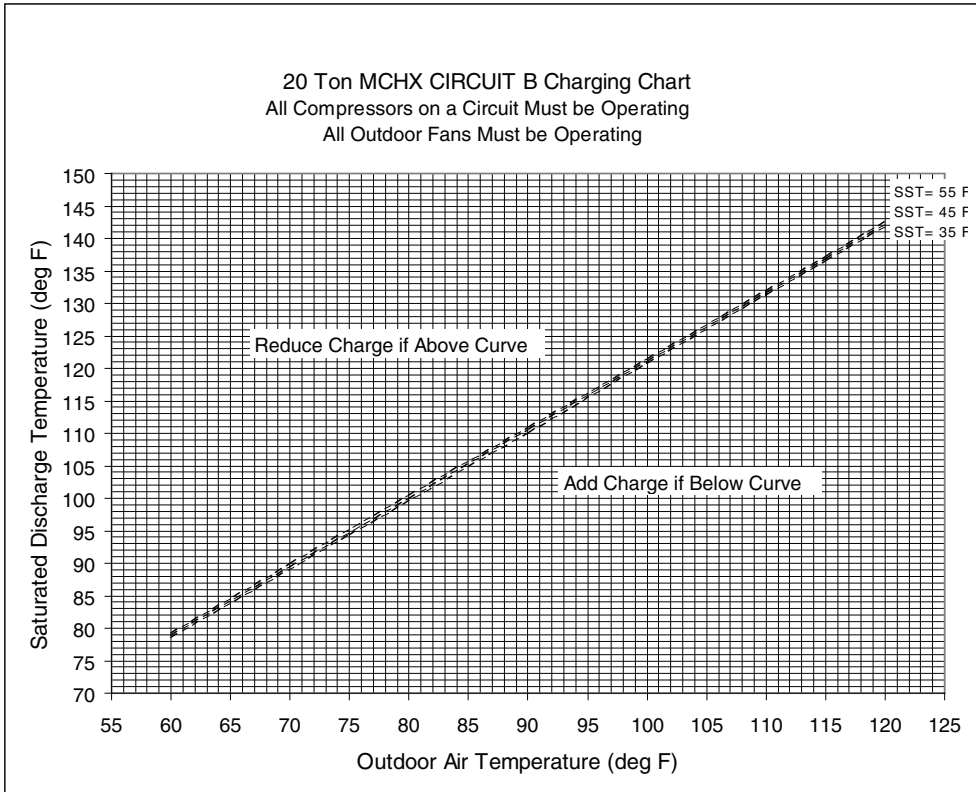
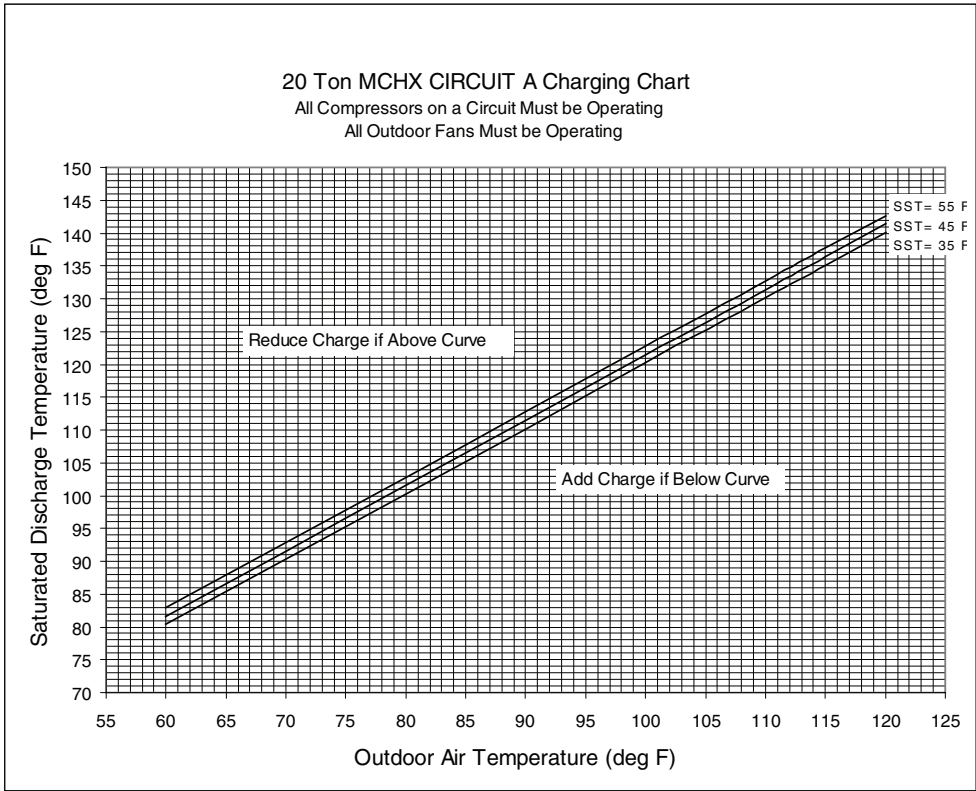
The regular factory setting is stamped on the valve body (3.5 in. wg).

To adjust regulator:

1. Set thermostat at setting for no call for heat.
2. Switch main gas valve to OFF position.
3. Remove 1/8-in. pipe plug from manifold. Install a water manometer pressure-measuring device.
4. Switch main gas valve to ON position.
5. Set thermostat at setting to call for heat (high fire).
6. Remove screw cap covering regulator adjustment screw (See Fig. 51).
7. Turn adjustment screw clockwise to increase pressure or counterclockwise to decrease pressure.
8. Once desired pressure is established, set unit to no call for heat (3.3-in. wg high fire).
9. Switch main gas valve to OFF position.
10. Remove pressure-measuring device and replace 1/8-in. pipe plug and screw cap.
11. Turn main gas valve to ON position and check heating operation.



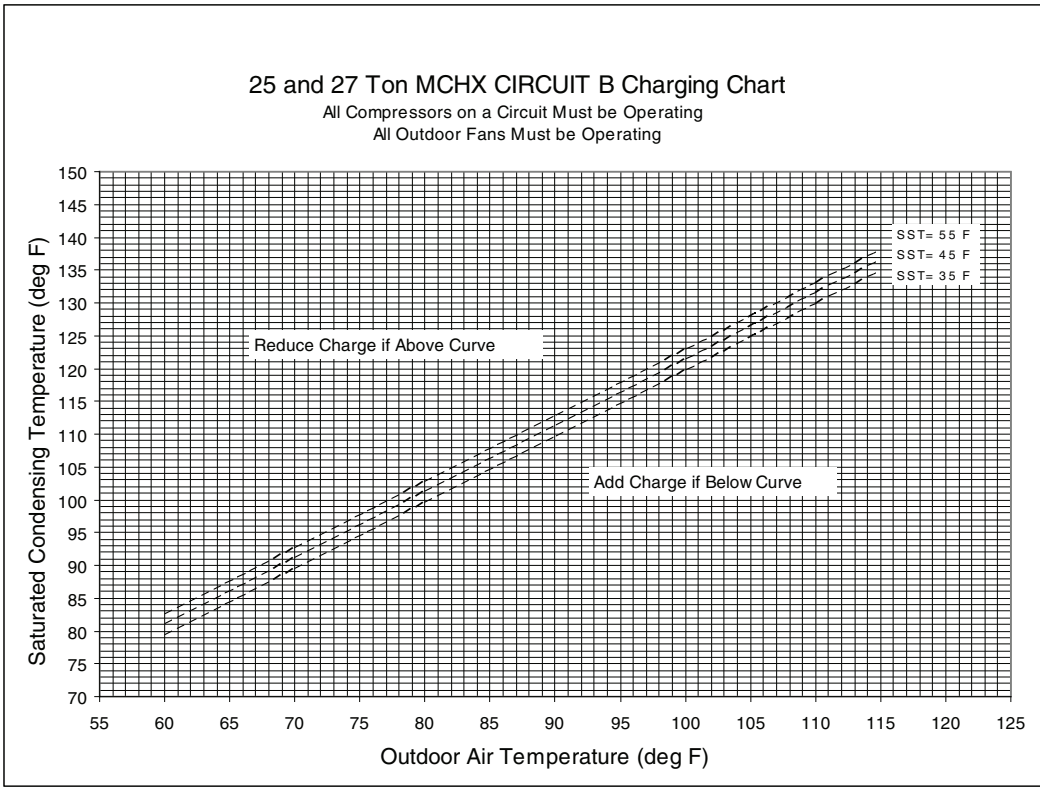
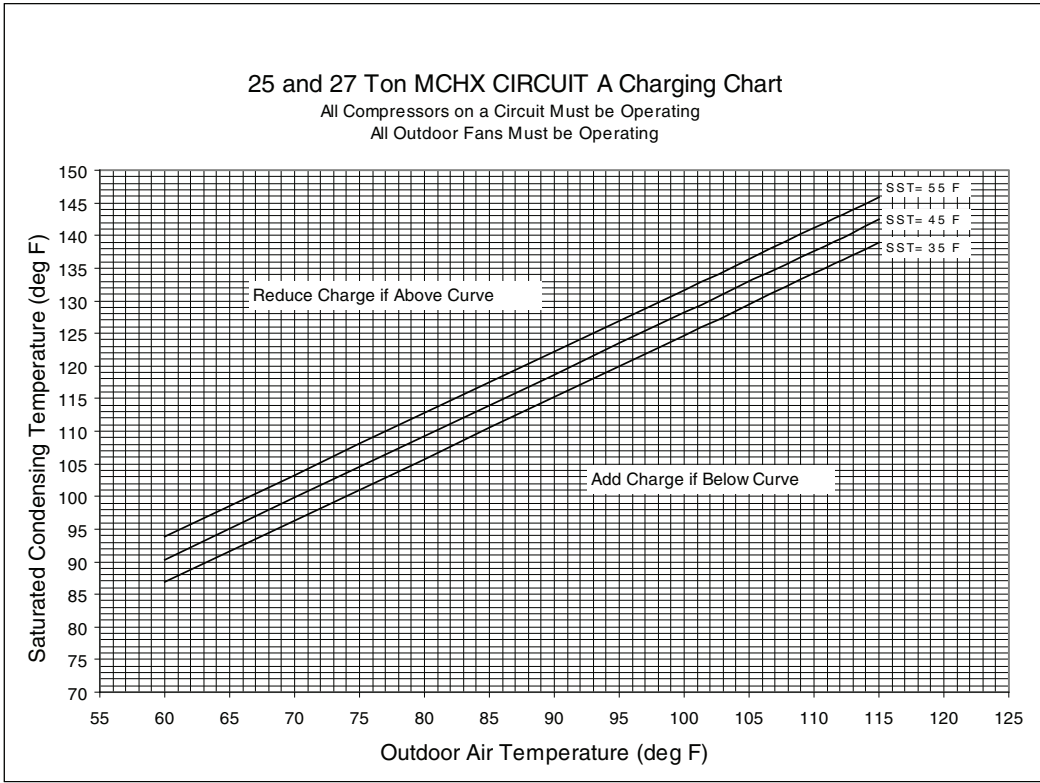
**Fig. 43 — Condenser-Fan Adjustment (All Units Except Size 060 MCHX)**



LEGEND

- MCHX — Microchannel Heat Exchanger
- SST — Saturated Suction Temperature

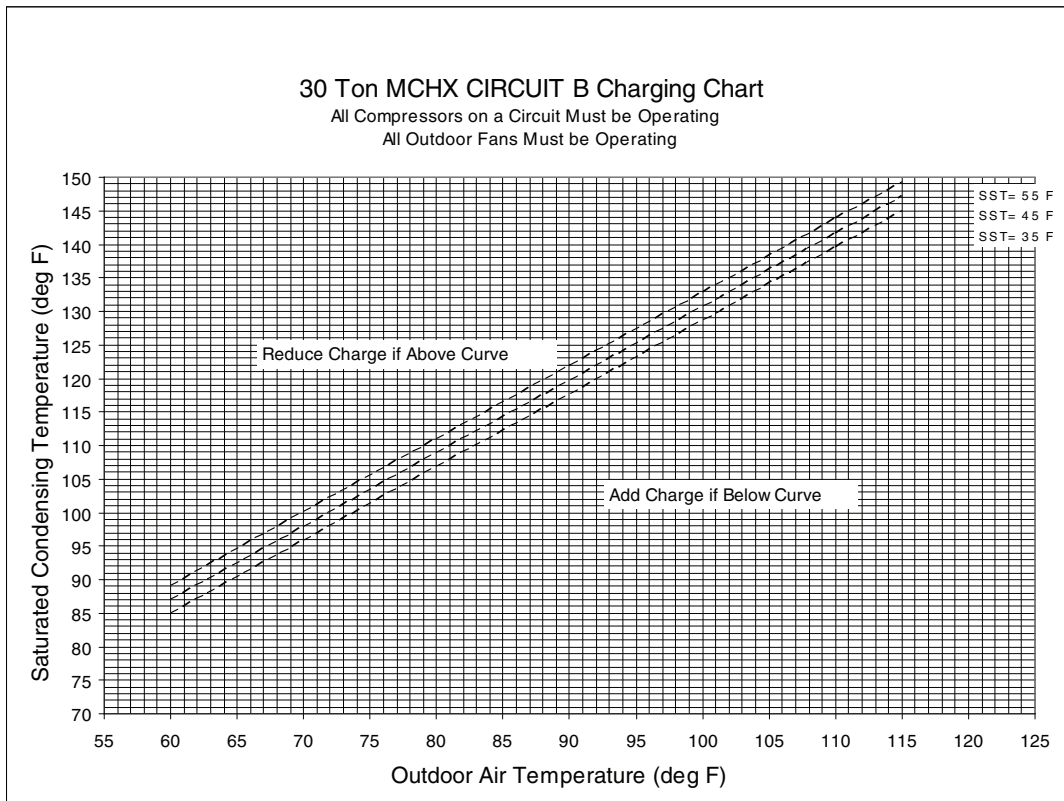
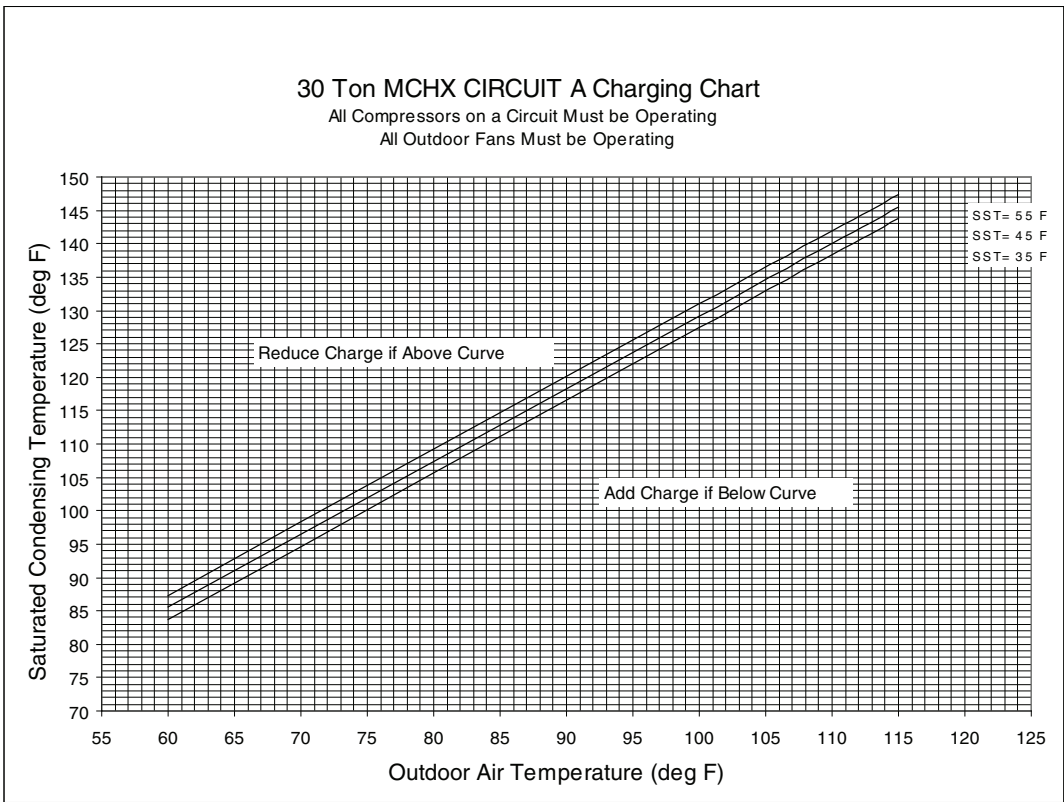
**Fig. 44 — Charging Chart — 48/50A2,A3,A4,A5020 with R-410A Refrigerant**



LEGEND

- MCHX — Microchannel Heat Exchanger
- SST — Saturated Suction Temperature

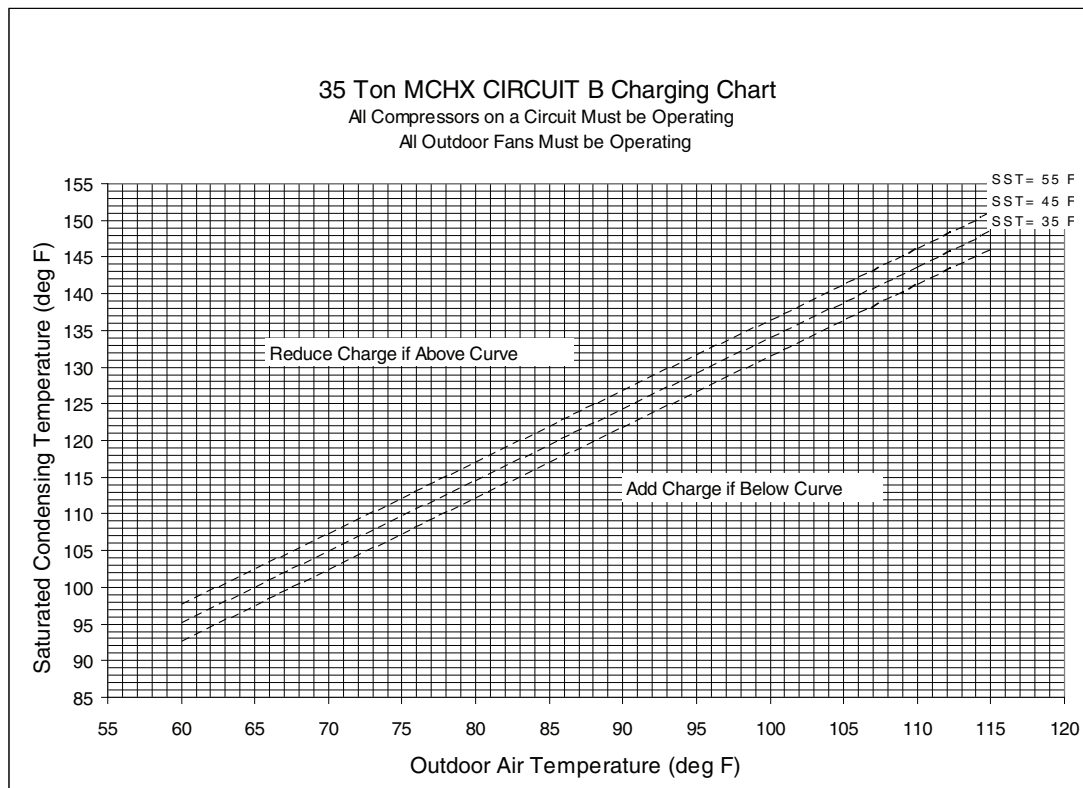
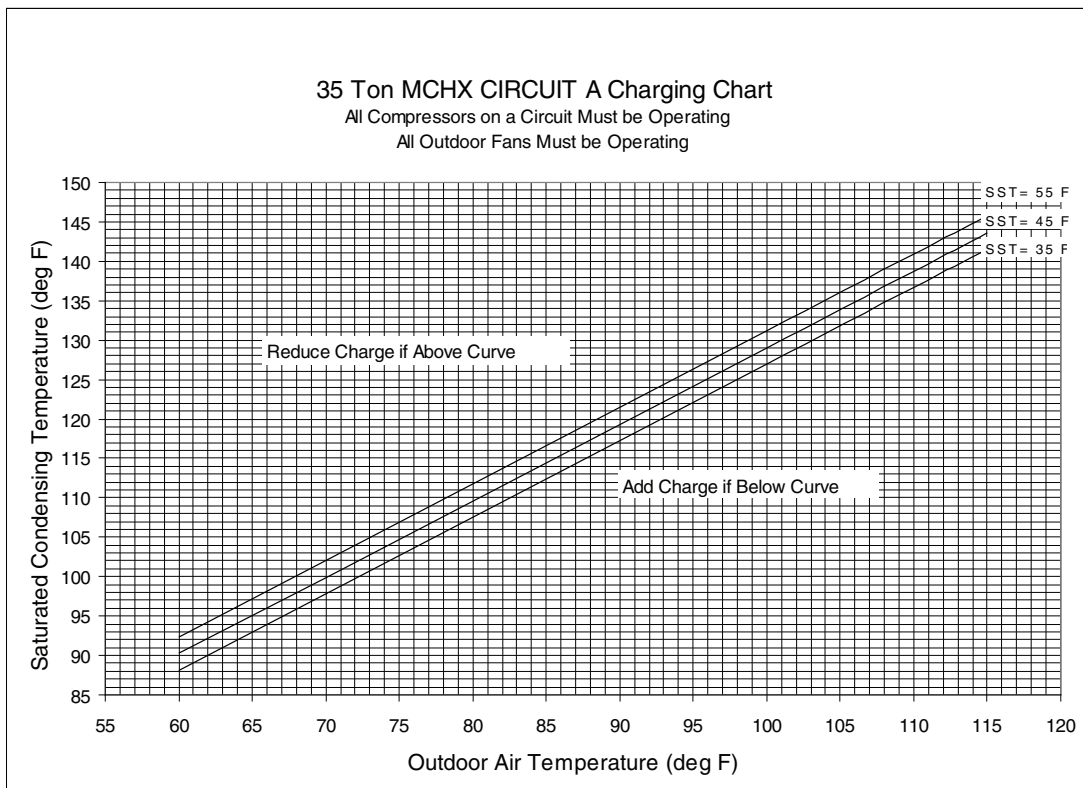
**Fig. 45 — Charging Chart — 48/50A2,A3,A4,A5025 and 027 with R-410A Refrigerant**



**LEGEND**

**MCHX** — Microchannel Heat Exchanger  
**SST** — Saturated Suction Temperature

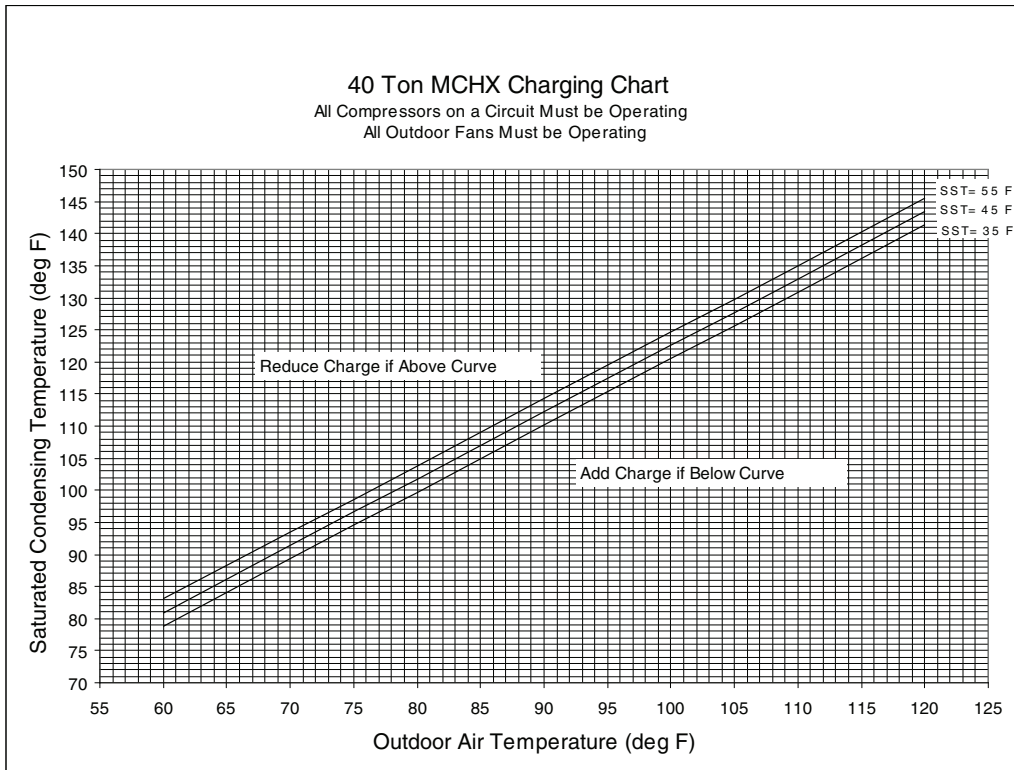
**Fig. 46 — Charging Chart — 48/50A2,A3,A4,A5030 with R-410A Refrigerant**



**LEGEND**

- MCHX** — Microchannel Heat Exchanger
- SST** — Saturated Suction Temperature

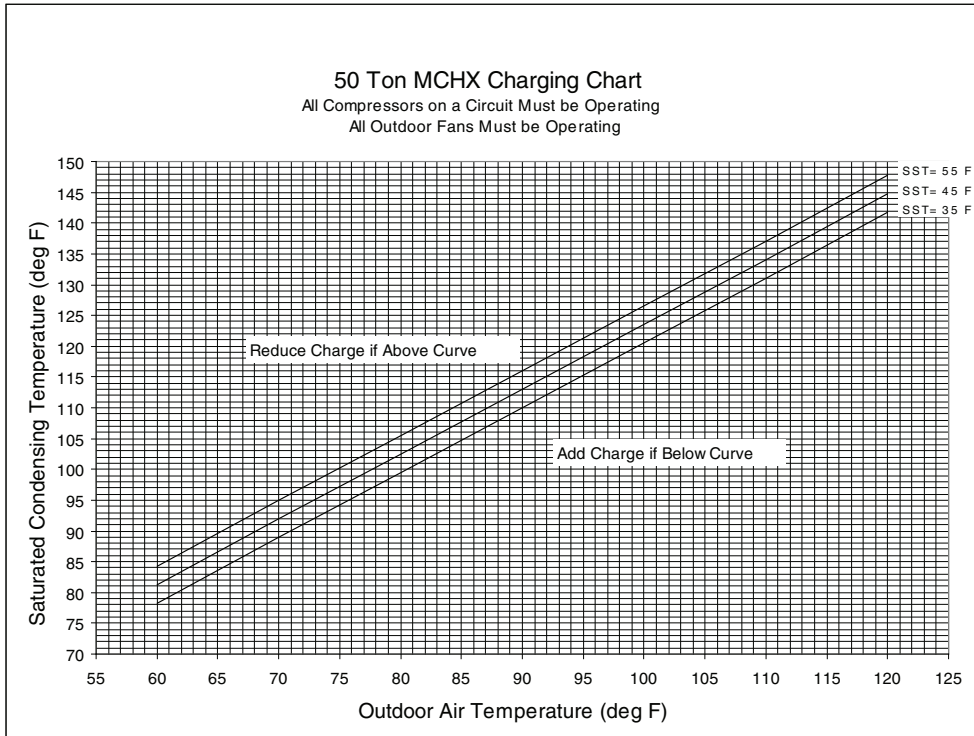
**Fig. 47 — Charging Chart — 48/50A2,A3,A4,A5035 with R-410A Refrigerant**



**LEGEND**

**MCHX** — Microchannel Heat Exchanger  
**SST** — Saturated Suction Temperature

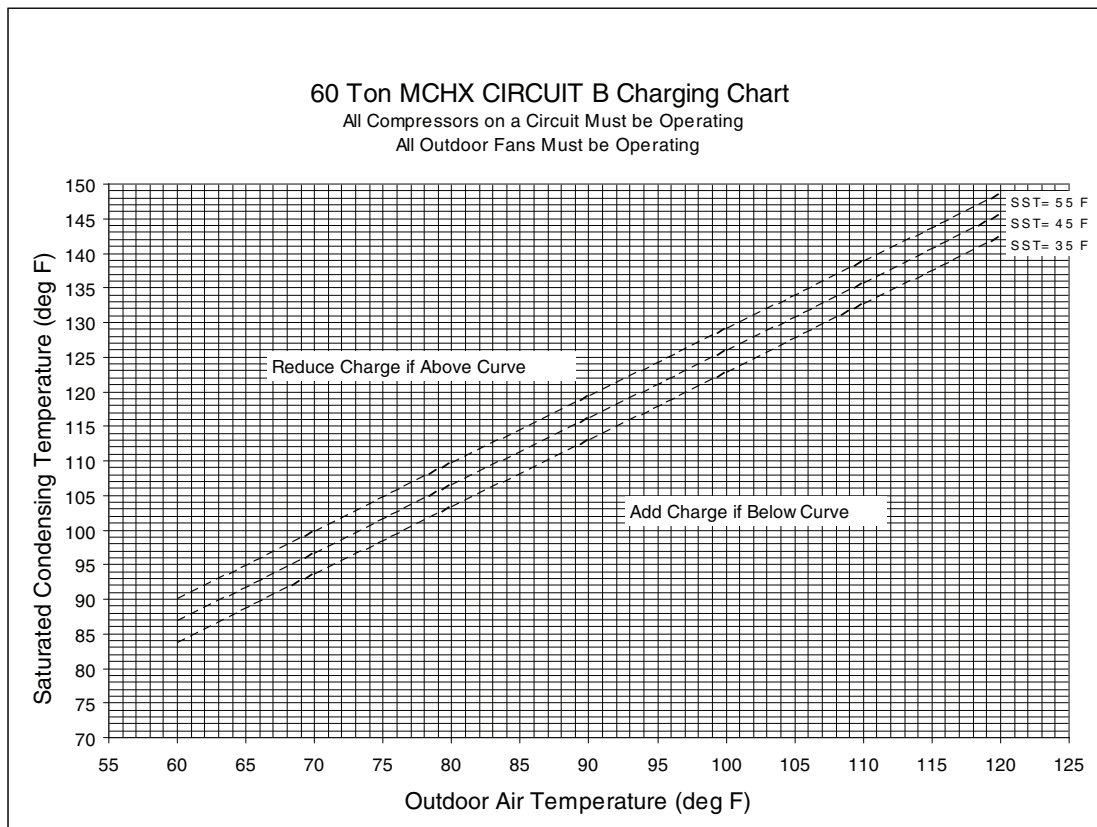
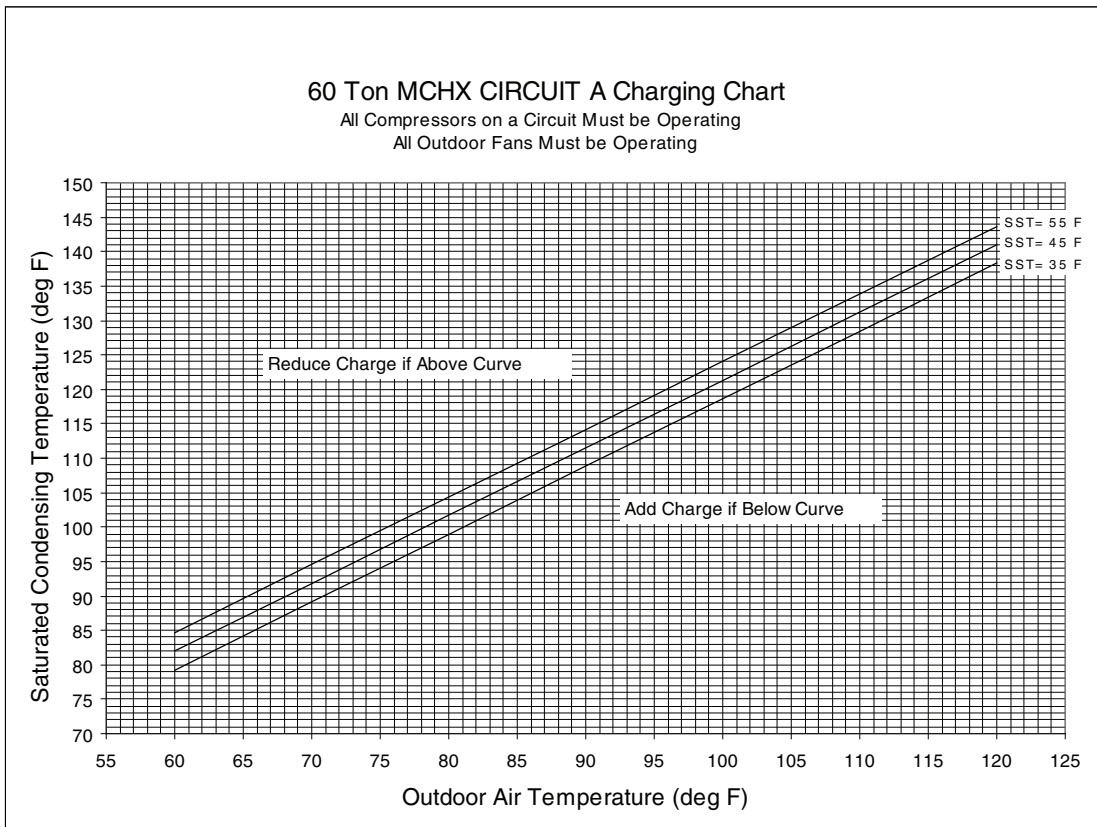
**Fig. 48 — Charging Chart — 48/50A2,A3,A4,A5040 with R-410A Refrigerant**



**LEGEND**

**MCHX** — Microchannel Heat Exchanger  
**SST** — Saturated Suction Temperature

**Fig. 49 — Charging Chart — 48/50A2,A3,A4,A5050 with R-410A Refrigerant**



LEGEND

**MCHX** — Microchannel Heat Exchanger  
**SST** — Saturated Suction Temperature

**Fig. 50 — Charging Chart — 48/50A2,A3,A4,A5060 with R-410A Refrigerant**



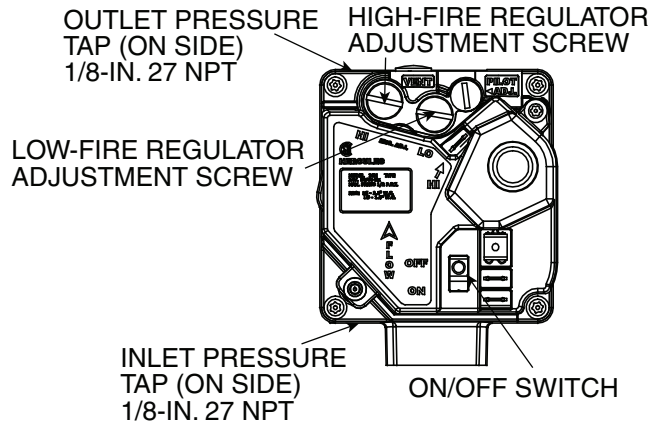
**Main Burners** — For all applications, main burners are factory set and should require no adjustment.

**MAIN BURNER REMOVAL (Fig. 52)**

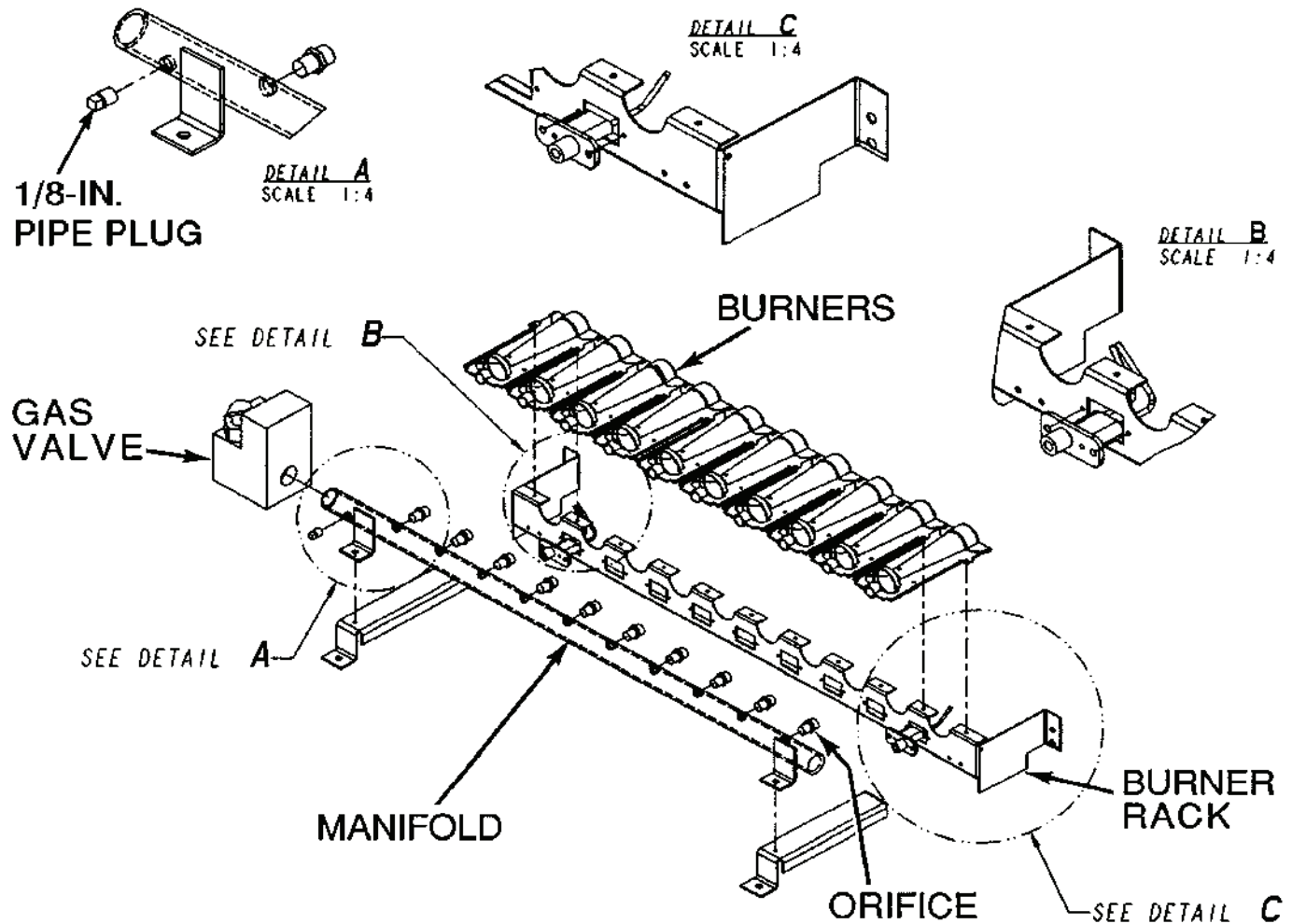
1. Shut off (field-supplied) manual main gas valve.
2. Shut off power supply to unit.
3. Remove heating access panel.
4. Disconnect gas piping from gas valve inlet.
5. Remove wires from gas valve.
6. Remove wires from rollout switch.
7. Remove sensor wire and ignitor cable from IGC board.
8. Remove 2 screws securing manifold bracket to basepan.
9. Remove 4 screws that hold the burner support plate flange to the vestibule plate.
10. Lift burner assembly out of unit.
11. Reverse procedure to re-install burners.

**Filter Drier** — Replace whenever refrigerant system is exposed to atmosphere.

**Replacement Parts** — A complete list of replacement parts may be obtained from any Carrier distributor upon request.



**Fig. 51 — Gas Valve (Part Number EF33CW271)**



**Fig. 52 — Main Burner Removal**



**APPENDIX A — LOCAL DISPLAY TABLES**

**MODE — RUN STATUS**

ITEM	EXPANSION	RANGE	UNITS	CCN POINT	WRITE STATUS	PAGE NO.
<b>VIEW</b>	AUTO VIEW OF RUN STATUS					
→HVAC	ascii string spelling out the hvac modes			string		91,92
→OCC	Occupied ?	YES/NO		OCCUPIED	forcible	91,92
→MAT	Mixed Air Temperature		dF	MAT		91,92
→EDT	Evaporator Discharge Tmp		dF	EDT		91,92
→LAT	Leaving Air Temperature		dF	LAT		91,92
→EC.C.P	Economizer Control Point		dF	ECONCPNT		50,63,64,71,91,92
→ECN.P	Economizer Act.Curr.Pos.	0-100	%	ECONOPOS		91,92
→CL.C.P	Cooling Control Point		dF	COOLCPNT		41,42,64,91,92
→C.CAP	Current Running Capacity			CAPTOTAL		91,92
→HT.C.P	Heating Control Point		dF	HEATCPNT		53,91,92
→HT.ST	Requested Heat Stage			HT_STAGE		54-56,91,92
→H.MAX	Maximum Heat Stages			HTMAXSTG		54,91,92
<b>ECON</b>	ECONOMIZER RUN STATUS					
→ECN.P	Economizer Act.Curr.Pos.	0-100	%	ECONOPOS	forcible	50,64,92
→ECN.C	Economizer Act.Cmd.Pos.	0-100	%	ECONOCMD		64,92
→ACTV	Economizer Active ?	YES/NO		EACTIVE		42,50,64,92
→DISA	ECON DISABLING CONDITIONS					64,92
→DISA→UNAV	Econ Act. Unavailable?	YES/NO		ECONUNAV		64,92
→DISA→R.EC.D	Remote Econ. Disabled ?	YES/NO		ECONDISA		64,92
→DISA→DBC	DBC - OAT Lockout?	YES/NO		DBC_STAT		64,92
→DISA→DEW	DEW - OA Dewpt.Lockout?	YES/NO		DEW_STAT		64,92
→DISA→DDBC	DDBD- OAT > RAT Lockout?	YES/NO		DDBCSTAT		64,92
→DISA→OAEC	OAEC- OA Enth Lockout?	YES/NO		OAECSTAT		64,92
→DISA→DEC	DEC - Diff.Enth.Lockout?	YES/NO		DEC_STAT		64,92
→DISA→EDT	EDT Sensor Bad?	YES/NO		EDT_STAT		64,92
→DISA→OAT	OAT Sensor Bad ?	YES/NO		OAT_STAT		64,92
→DISA→FORC	Economizer Forced ?	YES/NO		ECONFORC		64,92
→DISA→SFON	Supply Fan Not On 30s ?	YES/NO		SFONSTAT		64,92
→DISA→CLOF	Cool Mode Not In Effect?	YES/NO		COOL_OFF		64,92
→DISA→OAQL	OAQ Lockout in Effect ?	YES/NO		OAQLOCKD		64,92
→DISA→HELD	Econ Recovery Hold Off?	YES/NO		ECONHELD		64,92
→DISA→DH.DS	Dehumid. Disabled Econ?	YES/NO		DHDISABL		64,92
→O.AIR	OUTSIDE AIR INFORMATION					64,92
→O.AIR→OAT	Outside Air Temperature		dF	OAT	forcible	64,92
→O.AIR→OA.RH	Outside Air Rel. Humidity		%	OARH	forcible	64,92
→O.AIR→OA.E	Outside Air Enthalpy			OAE		64,92
→O.AIR→OA.D.T	OutsideAir Dewpoint Temp		dF	OADEWTMP		64,92
<b>COOL</b>	COOLING INFORMATION					
→C.CAP	Current Running Capacity		%	CAPTOTAL	forcible	46,47,49,91,93
→CUR.S	Current Cool Stage			COOL_STG		46,47,64,91,93
→REQ.S	Requested Cool Stage			CL_STAGE		46,47,91,93
→MAX.S	Maximum Cool Stages			CLMAXSTG		46,47,91,93
→DEM.L	Active Demand Limit			DEM_LIM		46-48,91,93
→SUMZ	COOL CAP. STAGE CONTROL					46,47,91,93
→SUMZ→SMZ	Capacity Load Factor		%	SMZ		46,47,91,93
→SUMZ→ADD.R	Next Stage EDT Decrease		^F	ADDRISE		43,46,47,91,93
→SUMZ→SUB.R	Next Stage EDT Increase		^F	SUBRISE		46,47,91,93
→SUMZ→R.PCT	Rise Per Percent Capacity			RISE_PCT		46,47,91,93
→SUMZ→Y.MIN	Cap Deadband Subtracting			Y_MINUS		46,47,91,93
→SUMZ→Y.PLU	Cap Deadband Adding			Y_PLUS		46,47,91,93
→SUMZ→Z.MIN	Cap Threshold Subtracting			Z_MINUS		46,47,92,93
→SUMZ→Z.PLU	Cap Threshold Adding			Z_PLUS		46,47,92,93
→SUMZ→H.TMP	High Temp Cap Override			HI_TEMP		46,47,92,93
→SUMZ→L.TMP	Low Temp Cap Override			LOW_TEMP		46,47,92,93
→SUMZ→PULL	Pull Down Cap Override			PULLDOWN		46,47,92,93
→SUMZ→SLOW	Slow Change Cap Override			SLO_CHNG		47,92,93
<b>TRIP</b>	MODE TRIP HELPER					
→UN.C.S	Unoccup. Cool Mode Start			UCCLSTRT		46,53,93
→UN.C.E	Unoccup. Cool Mode End			UCCL_END		46,53,93
→OC.C.S	Occupied Cool Mode Start			OCCLSTRT		46,53,93
→OC.C.E	Occupied Cool Mode End			OCCL_END		46,53,93
→TEMP	Ctl.Temp RAT,SPT or Zone			CTRLTEMP		46,53,93
→OC.H.E	Occupied Heat Mode End			OCHT_END		46,53,93
→OC.H.S	Occupied Heat Mode Start			OCHTSTRT		46,53,93
→UN.H.E	Unoccup. Heat Mode End			UCHT_END		46,53,93
→UN.H.S	Unoccup. Heat Mode Start			UCHTSTRT		46,53,93
→HVAC	ascii string spelling out the hvac modes			string		46,53,93
<b>LINK</b>	CCN - LINKAGE					
→MODE	Linkage Active - CCN	ON/OFF		MODELINK		93
→L.Z.T	Linkage Zone Control Tmp		dF	LZT		93
→L.C.SP	Linkage Curr. Cool Setpt		dF	LCSP		93
→L.H.SP	Linkage Curr. Heat Setpt		dF	LHSP		93
<b>HRS</b>	COMPRESSOR RUN HOURS					
→HR.A1	Compressor A1 Run Hours	0-999999	HRS	HR_A1	config	93
→HR.A2	Compressor A2 Run Hours	0-999999	HRS	HR_A2	config	93
→HR.B1	Compressor B1 Run Hours	0-999999	HRS	HR_B1	config	93
→HR.B2	Compressor B2 Run Hours	0-999999	HRS	HR_B2	config	93
<b>STRT</b>	COMPRESSOR STARTS					
→ST.A1	Compressor A1 Starts	0-999999		CY_A1	config	93
→ST.A2	Compressor A2 Starts	0-999999		CY_A2	config	93
→ST.B1	Compressor B1 Starts	0-999999		CY_B1	config	93
→ST.B2	Compressor B2 Starts	0-999999		CY_B2	config	93

**APPENDIX A — LOCAL DISPLAY TABLES (cont)**  
**MODE — RUN STATUS (cont)**

ITEM	EXPANSION	RANGE	UNITS	CCN POINT	WRITE STATUS	PAGE NO.
<b>TMGD</b>	<b>TIMEGUARDS</b>					
→ <b>TG.A1</b>	Compressor A1 Timeguard			CMPA1_TG		94
→ <b>TG.A2</b>	Compressor A2 Timeguard			CMPA2_TG		94
→ <b>TG.B1</b>	Compressor B1 Timeguard			CMPB1_TG		94
→ <b>TG.B2</b>	Compressor B2 Timeguard			CMPB2_TG		94
→ <b>TG.H1</b>	Heat Relay 1 Timeguard			HS1_TG		94
→ <b>TG.H2</b>	Heat Relay 2 Timeguard			HS2_TG		94
→ <b>TG.H3</b>	Heat Relay 3 Timeguard			HS3_TG		94
→ <b>TG.H4</b>	Heat Relay 4 Timeguard			HS4_TG		94
→ <b>TG.H5</b>	Heat Relay 5 Timeguard			HS5_TG		94
→ <b>TG.H6</b>	Heat Relay 6 Timeguard			HS6_TG		94
<b>VERS</b>	<b>SOFTWARE VERSION NUMBERS</b>					
→ <b>MBB</b>	CESR131343-xx-xx			string		94
→ <b>ECB1</b>	CESR131249-xx-xx			string		94
→ <b>ECB2</b>	CESR131249-xx-xx			string		94
→ <b>SCB</b>	CESR131226-xx-xx			string		94
→ <b>CEM</b>	CESR131174-xx-xx			string		94
→ <b>MARQ</b>	CESR131171-xx-xx			string		94
→ <b>NAVI</b>	CESR130227-xx-xx			string		94

**MODE — SERVICE TEST**

ITEM	EXPANSION	RANGE	UNITS	CCN POINT	WRITE STATUS	PAGE NO.
<b>TEST</b>	Service Test Mode	ON/OFF		MAN_CTRL		
<b>STOP</b>	Local Machine Disable	YES/NO		UNITSTOP	config	27,29,30,33
<b>S.STP</b>	Soft Stop Request	YES/NO		SOFTSTOP	forcible	29,30
<b>FAN.F</b>	Supply Fan Request	YES/NO		SFANFORC	forcible	29,30
<b>F.4.CH</b>	4 in. Filter Change Mode	YES/NO		FILT4CHG		29,30
<b>INDP</b>	<b>TEST INDEPENDENT OUTPUTS</b>					
→ <b>ECN.C</b>	Economizer Act.Cmd.Pos.			ECONCTST		30
→ <b>E.PWR</b>	Economizer Power Test			ECONPTST		30
→ <b>E.CAL</b>	Calibrate the Economizer?			ECON_CAL		30
→ <b>PE.A</b>	Power Exhaust Relay A			PE_A_TST		30
→ <b>PE.B</b>	Power Exhaust Relay B			PE_B_TST		30
→ <b>PE.C</b>	Power Exhaust Relay C			PE_C_TST		30
→ <b>H.I.R</b>	Heat Interlock Relay	ON/OFF		HIR_TST		30
→ <b>ALRM</b>	Remote Alarm/Aux Relay	ON/OFF		ALRM_TST		30
<b>FANS</b>	<b>TEST FANS</b>					
→ <b>S.FAN</b>	Supply Fan Relay	ON/OFF		SFAN_TST		30
→ <b>S.VFD</b>	Supply Fan VFD Speed	0-100	%	SGVFDTST		30
→ <b>CD.FA</b>	Condenser Fan Circuit A	ON/OFF		CNDA_TST		30
→ <b>CD.FB</b>	Condenser Fan Circuit B	ON/OFF		CNDB_TST		30
<b>COOL</b>	<b>TEST COOLING</b>					
→ <b>A1</b>	Compressor A1 Relay	ON/OFF		CMPA1TST		30
→ <b>A2</b>	Compressor A2 Relay	ON/OFF		CMPA2TST		30
→ <b>MLV</b>	Min. Load Valve (HGBP)	ON/OFF		MLV_TST		30
→ <b>B1</b>	Compressor B1 Relay	ON/OFF		CMPB1TST		30
→ <b>B2</b>	Compressor B2 Relay	ON/OFF		CMPB2TST		30
<b>HEAT</b>	<b>TEST HEATING</b>					
→ <b>HT.ST</b>	Requested Heat Stage	0-MAX		HTST_TST		30
→ <b>HT.1</b>	Heat Relay 1	ON/OFF		HS1_TST		30
→ <b>HT.2</b>	Heat Relay 2	ON/OFF		HS2_TST		30
→ <b>HT.3</b>	Relay 3 W1 Gas Valve 2	ON/OFF		HS3_TST		30
→ <b>HT.4</b>	Relay 4 W2 Gas Valve 2	ON/OFF		HS4_TST		30
→ <b>HT.5</b>	Relay 5 W1 Gas Valve 3	ON/OFF		HS5_TST		30
→ <b>HT.6</b>	Relay 6 W2 Gas Valve 3	ON/OFF		HS6_TST		30

**MODE — TEMPERATURES**

ITEM	EXPANSION	RANGE	UNITS	CCN POINT	WRITE STATUS
<b>AIR.T</b>	<b>AIR TEMPERATURES</b>				
→ <b>CTRL</b>	<b>CONTROL TEMPS</b>				
→ <b>CTRL→EDT</b>	Evaporator Discharge Tmp		dF	EDT	
→ <b>CTRL→LAT</b>	Leaving Air Temperature		dF	LAT	
→ <b>CTRL→MAT</b>	Mixed Air Temperature		dF	MAT	
→ <b>CTRL→R.TMP</b>	Controlling Return Temp		dF	RETURN_T	forcible
→ <b>CTRL→S.TMP</b>	Controlling Space Temp		dF	SPACE_T	forcible
→ <b>SAT</b>	Air Tmp Lvg Supply Fan		dF	SAT	
→ <b>OAT</b>	Outside Air Temperature	-40 - 240	dF	OAT	forcible
→ <b>RAT</b>	Return Air Temperature		dF	RAT	forcible
→ <b>SPT</b>	Space Temperature	-40 - 240	dF	SPT	forcible
→ <b>SPTO</b>	Space Temperature Offset		^F	SPTO	forcible
→ <b>S.G.LS</b>	Staged Gas LAT Sum		dF	LAT_SGAS	
→ <b>S.G.L1</b>	Staged Gas LAT 1		dF	LAT1SGAS	
→ <b>S.G.L2</b>	Staged Gas LAT 2		dF	LAT2SGAS	
→ <b>S.G.L3</b>	Staged Gas LAT 3		dF	LAT3SGAS	
→ <b>S.G.LM</b>	Staged Gas Limit Sw.Temp		dF	LIMSWTMP	
<b>REF.T</b>	<b>REFRIGERANT TEMPERATURES</b>				
→ <b>SCT.A</b>	Cir A Sat.Condensing Temp		dF	SCTA	
→ <b>SST.A</b>	Cir A Sat.Suction Temp.		dF	SSTA	
→ <b>SCT.B</b>	Cir B Sat.Condensing Tmp		dF	SCTB	
→ <b>SST.B</b>	Cir B Sat.Suction Temp.		dF	SSTB	

**APPENDIX A — LOCAL DISPLAY TABLES (cont)**

**MODE — PRESSURES**

ITEM	EXPANSION	RANGE	UNITS	CCN POINT	WRITE STATUS
<b>AIR.P</b> → <b>SP</b> → <b>BP</b>	AIR PRESSURES Static Pressure Building Pressure		"H2O "H2O	SP BP	
<b>REF.P</b> → <b>DP.A</b> → <b>SP.A</b> → <b>DP.B</b> → <b>SP.B</b>	REFRIGERANT PRESSURES Cir A Discharge Pressure Cir A Suction Pressure Cir B Discharge Pressure Cir B Suction Pressure		PSIG PSIG PSIG PSIG	DP_A SP_A DP_B SP_B	

**MODE — SET POINTS**

ITEM	DESCRIPTION	RANGE	UNITS	CCN POINT	DEFAULT
<b>OHSP</b>	Occupied Heat Setpoint	40-99	dF	OHSP	68
<b>OCSP</b>	Occupied Cool Setpoint	40-99	dF	OCSP	75
<b>UHSP</b>	Unoccupied Heat Setpoint	40-99	dF	UHSP	55
<b>UCSP</b>	Unoccupied Cool Setpoint	40-99	dF	UCSP	90
<b>GAP</b>	Heat-Cool Setpoint Gap	2-10	^F	HCSP_GAP	5
<b>V.C.ON</b>	VAV Occ. Cool On Delta	0-25	^F	VAVOCON	3.5
<b>V.C.OF</b>	VAV Occ. Cool Off Delta	1-25	^F	VAVOCOFF	2
<b>SASP</b>	Supply Air Setpoint	45-75	dF	SASP	55
<b>SA.HI</b>	Supply Air Setpoint Hi	45-75	dF	SASP_HI	55
<b>SA.LO</b>	Supply Air Setpoint Lo	45-75	dF	SASP_LO	60
<b>SA.HT</b>	Heating Supply Air Setpt	80-120	dF	SASPHEAT	85
<b>T.PRG</b>	Tempering Purge SASP	-20-80	dF	TEMPPURG	50
<b>T.CL</b>	Tempering in Cool SASP	5-75	dF	TEMPCOOL	5
<b>T.V.OC</b>	Tempering Vent Occ SASP	-20-80	dF	TEMPVOCC	65
<b>T.V.UN</b>	Tempering Vent Unocc. SASP	-20-80	dF	TEMPVUNC	50

**MODE — INPUTS**

ITEM	EXPANSION	RANGE	UNITS	CCN POINT	WRITE STATUS
<b>GEN.I</b> → <b>FLT.S</b> → <b>G.FAN</b> → <b>REMT</b> → <b>E.SW</b> → <b>E.ENA</b> → <b>E.OVR</b> → <b>S.FN.S</b> → <b>DL.S1</b> → <b>DL.S2</b> → <b>DH.IN</b>	GENERAL INPUTS Filter Status Input Fan Request From IGC Remote Input State Economizer Control Input Remote Economizer Enable Econo Position Override Supply Fan Status Switch Demand Limit Switch 1 Demand Limit Switch 2 Dehumidify Switch Input	DRTY/CLN ON/OFF * YES/NO YES/NO YES/NO ON/OFF ON/OFF ON/OFF ON/OFF		FLTS IGCFAN RMTIN ECOSW ECONENBL ECOORIDE SFS DMD_SW1 DMD_SW2 DHDISCIN	forcible forcible forcible forcible forcible forcible forcible forcible
<b>FD.BK</b> → <b>CS.A1</b> → <b>CS.A2</b> → <b>CS.B1</b> → <b>CS.B2</b>	COMPRESSOR FEEDBACK Compressor A1 Feedback Compressor A2 Feedback Compressor B1 Feedback Compressor B2 Feedback	ON/OFF ON/OFF ON/OFF ON/OFF		CSB_A1 CSB_A2 CSB_B1 CSB_B2	
<b>STAT</b> → <b>G</b> → <b>W1</b> → <b>W2</b> → <b>Y1</b> → <b>Y2</b>	THERMOSTAT INPUTS Thermostat G Input Thermostat W1 Input Thermostat W2 Input Thermostat Y1 Input Thermostat Y2 Input	ON/OFF ON/OFF ON/OFF ON/OFF ON/OFF		G W1 W2 Y1 Y2	forcible forcible forcible forcible forcible
<b>FIRE</b> → <b>FSD</b> → <b>PRES</b> → <b>EVAC</b> → <b>PURG</b>	FIRE-SMOKE INPUTS Fire Shutdown Input Pressurization Input Evacuation Input Smoke Purge Input	ALARM/NORMAL ALARM/NORMAL ALARM/NORMAL ALARM/NORMAL		FSD PRES EVAC PURG	forcible forcible forcible forcible
<b>REL.H</b> → <b>OA.RH</b> → <b>OA.EN</b> → <b>OA.DP</b> → <b>RA.RH</b> → <b>RA.EN</b>	RELATIVE HUMIDITY Outside Air Rel. Humidity Outdoor Air Enthalpy Outside Air Dewpoint Temp Return Air Rel. Humidity Return Air Enthalpy		% dF %	OARH OAE OADEWTMP RARH RAE	forcible forcible
<b>AIR.Q</b> → <b>IAQ.I</b> → <b>IAQ</b> → <b>OAQ</b> → <b>DAQ</b> → <b>IQ.P.O</b>	AIR QUALITY SENSORS IAQ - Discrete Input IAQ - PPM Return CO2 OAQ - PPM Return CO2 Diff. Air Quality in PPM IAQ Min.Pos. Override	HIGH/LOW		IAQIN IAQ OAQ DAQ IAQMINOV	forcible forcible forcible forcible
<b>RSET</b> → <b>SA.S.R</b> → <b>SP.RS</b>	RESET INPUTS Supply Air Setpnt. Reset Static Pressure Reset		^F	SASPRSET SPRESET	forcible forcible

\*The display text changes depending on the remote switch configuration (**Configuration**→**UNIT**→**RM.CF**). If **RM.CF** is set to 0 (No Remote Switch), then the display text will be "On" or "Off." If **RM.CF** is set to 1 (Occupied/Unoccupied Switch), then the display text will be "Occupied" or "Unoccupied." If **RM.CF** is set to 2 (Start/Stop), then the display text will be "Stop" or "Start." If **RM.CF** is set to 3 (Override Switch), then the display text will be "No Override" or "Override."

**APPENDIX A — LOCAL DISPLAY TABLES (cont)**

**MODE — INPUTS (cont)**

ITEM	EXPANSION	RANGE	UNITS	CCN POINT	WRITE STATUS	
<b>4-20</b>	4-20 MILLIAMPS INPUTS					
→ <b>IAQ.M</b>	IAQ Milliamps		ma	IAQ_MA	forcible	
→ <b>OAQ.M</b>	OAQ Milliamps		ma	OAQ_MA		
→ <b>SP.R.M</b>	SP Reset milliamps		ma	SPRST_MA		
→ <b>DML.M</b>	4-20 ma Demand Signal		ma	DMDLMTMA		
→ <b>EDR.M</b>	EDT Reset Milliamps		ma	EDTRESMA		
→ <b>ORH.M</b>	OARH Milliamps		ma	OARH_MA		
→ <b>RRH.M</b>	RARH Milliamps		ma	RARH_MA		
→ <b>BP.M</b>	BP Milliamps		ma	BP_MA		
→ <b>BP.M.T</b>	Bldg. Pressure Trim (ma)	-2.0 - 2.0		BPMATRIM		config
→ <b>SP.M</b>	SP Milliamps		ma	SP_MA		
→ <b>SP.M.T</b>	Static Press. Trim (ma)	-2.0 - 2.0		SPMATRIM		

\*The display text changes depending on the remote switch configuration (**Configuration**→**UNIT**→**RM.CF**). If **RM.CF** is set to 0 (No Remote Switch), then the display text will be "On" or "Off." If **RM.CF** is set to 1 (Occupied/Unoccupied Switch), then the display text will be "Occupied" or "Unoccupied." If **RM.CF** is set to 2 (Start/Stop), then the display text will be "Stop" or "Start." If **RM.CF** is set to 3 (Override Switch), then the display text will be "No Override" or "Override."

**MODE — OUTPUTS**

ITEM	EXPANSION	RANGE	UNITS	CCN POINT	WRITE STATUS	
<b>FANS</b>	FANS					
→ <b>S.FAN</b>	Supply Fan Relay	ON/OFF		SFAN_RLY	forcible	
→ <b>S.VFD</b>	Supply Fan VFD Speed	0-100	%	SFAN_VFD		
→ <b>P.E.A</b>	Power Exhaust Relay A	ON/OFF		PE_A		
→ <b>P.E.B</b>	Power Exhaust Relay B	ON/OFF		PE_B		
→ <b>P.E.C</b>	Power Exhaust Relay C	ON/OFF		PE_C		
→ <b>CD.FA</b>	Condenser Fan Circuit A	ON/OFF		CONDFANA		
→ <b>CD.FB</b>	Condenser Fan Circuit B	ON/OFF		CONDFANB		
<b>COOL</b>	COOLING					
→ <b>A1</b>	Compressor A1 Relay	ON/OFF		CMPA1		forcible
→ <b>A2</b>	Compressor A2 Relay	ON/OFF		CMPA2		
→ <b>MLV</b>	Min. Load Valve (HGBP)	ON/OFF		MLV		
→ <b>B1</b>	Compressor B1 Relay	ON/OFF		CMPB1		
→ <b>B2</b>	Compressor B2 Relay	ON/OFF		CMPB2		
<b>HEAT</b>	HEATING					
→ <b>HT.1</b>	Heat Relay 1	ON/OFF		HS1	forcible	
→ <b>HT.2</b>	Heat Relay 2	ON/OFF		HS2		
→ <b>HT.3</b>	Relay 3 W1 Gas Valve 2	ON/OFF		HS3		
→ <b>HT.4</b>	Relay 4 W2 Gas Valve 2	ON/OFF		HS4		
→ <b>HT.5</b>	Relay 5 W1 Gas Valve 3	ON/OFF		HS5		
→ <b>HT.6</b>	Relay 6 W2 Gas Valve 3	ON/OFF		HS6		
→ <b>H.I.R</b>	Heat Interlock Relay	ON/OFF		HIR		
<b>ECON</b>	ECONOMIZER					
→ <b>ECN.P</b>	Economizer Act.Curr.Pos.	0-100	%	ECONOPOS	forcible	
→ <b>ECN.C</b>	Economizer Act.Cmd.Pos.	0-100	%	ECONOCMD		
→ <b>E.PWR</b>	Economizer Power Relay	ON/OFF		ECON_PWR		
<b>GEN.O</b>	GENERAL OUTPUTS					
<b>ALRM</b>	Remote Alarm/Aux Relay	ON/OFF		ALRM	forcible	

**MODE — CONFIGURATION**

ITEM	EXPANSION	RANGE	UNITS	CCN POINT	DEFAULT	PAGE NO.
<b>UNIT</b>	UNIT CONFIGURATION					
→ <b>C.TYP</b>	Machine Control Type	1 - 6 (multi-text strings)		CTRLTYPE	4	27,28,32,35-37, 63,76,97
→ <b>CV.FN</b>	Fan Mode (0=Auto, 1=Cont)	0 - 1 (multi-text strings)		FAN_MODE	1	27,28,35,36
→ <b>RM.CF</b>	Remote Switch Config	0 - 3 (multi-text strings)		RMTINCFG	0	31,35,36,75
→ <b>CEM</b>	CEM Module Installed	Yes/No		CEM_BRD	No	35,36
→ <b>TCS.C</b>	Temp.Cmp.Strt.Cool Factr	0 - 60	min	TCSTCOOL	0	35,36,71
→ <b>TCS.H</b>	Temp.Cmp.Strt.Heat Factr	0 - 60	min	TCSTHEAT	0	36,71
→ <b>SFS.S</b>	Fan Fail Shuts Down Unit	Yes/No		SFS_SHUT	No	36,60,101
→ <b>SFS.M</b>	Fan Stat Monitoring Type	0 - 2 (multi-text strings)		SFS_MON	0	35,36,60,101
→ <b>VAV.S</b>	VAV Unocc.Fan Retry Time	0 - 720	min	SAMPMINS	50	36
→ <b>SIZE</b>	Unit Size (20-60)	20 - 60		UNITSIZE	20	36,38,42,49
→ <b>DP.XR</b>	Disch.Press. Transducers	Yes/No		DP_TRANS	No	36,98
→ <b>SP.XR</b>	Suct. Pres. Trans. Type	0 - 1 (multi-text strings)		SPXRTYPE	0	36
→ <b>RFG.T</b>	Refrig: 0=R22 1=R410A	0 - 1 (multi-text strings)		REFRIG_T	1	36,38,49
→ <b>CND.T</b>	Cnd HX Typ:0=RTPF 1=MCHX	0 - 1 (multi-text strings)		COILTYPE	0	36,38,49
→ <b>MAT.S</b>	MAT Calc Config	0 - 2 (multi-text strings)		MAT_SEL	1	36,47,48
→ <b>MAT.R</b>	Reset MAT Table Entries?	Yes/No		MATRESET	No	36,37,47,48
→ <b>MAT.D</b>	MAT Outside Air Default	0-100	%	MATOADOS	20	36,37
→ <b>ALTI</b>	Altitude.....in feet:	0 - 60000		ALTITUDE	0	36,37
→ <b>DLAY</b>	Startup Delay Time	0 - 900	sec	DELAY	0	36,37
→ <b>STAT</b>	TSTAT-Both Heat and Cool	Yes/No		TSTATALL	No	36,37
→ <b>AUX.R</b>	Auxiliary Relay Config	0 - 3		AUXRELAY	0	36,37
→ <b>SENS</b>	INPUT SENSOR CONFIG					36
→ <b>SENS</b> → <b>SPT.S</b>	Space Temp Sensor	Enable/Disable		SPTSSENS	Disable	27,28,36,37
→ <b>SENS</b> → <b>SP.O.S</b>	Space Temp Offset Sensor	Enable/Disable		SPTOSENS	Disable	36,37,76
→ <b>SENS</b> → <b>SP.O.R</b>	Space Temp Offset Range	1 - 10		SPTO_RNG	5	36,37,76
→ <b>SENS</b> → <b>RRH.S</b>	Return Air RH Sensor	Enable/Disable		RARHSENS	Disable	36,37,62,98,100
→ <b>SENS</b> → <b>FLT.S</b>	Filter Stat.Sw.Enabled ?	Enable/Disable		FLTS_ENA	Disable	36,37,60,101

**APPENDIX A — LOCAL DISPLAY TABLES (cont)**

**MODE — CONFIGURATION (cont)**

ITEM	EXPANSION	RANGE	UNITS	CCN POINT	DEFAULT	PAGE NO.
<b>COOL</b>	<b>COOLING CONFIGURATION</b>					
→Z.GN	Capacity Threshold Adjst	-10 - 10		Z_GAIN	1	39,46,92
→MC.LO	Compressor Lockout Temp	-20 - 55	dF	OATLCOMP	40	39,48
→C.FOD	Fan-Off Delay, Mech Cool	0 - 600	sec	COOL_FOD	60	39
→MLV	Min. Load Valve? (HGBP)	Yes/No		MLV_SEL	No	39,76
→M.M.	Motor Master Control	Yes/No		MOTRMAST	No	39,49
→HPSP	Head Pressure Setpoint	80 - 150	dF	HPSP	113	39,49
→A1.EN	Enable Compressor A1	Enable/Disable		CMPA1ENA	Enable	39
→A2.EN	Enable Compressor A2	Enable/Disable		CMPA2ENA	Enable	39
→B1.EN	Enable Compressor B1	Enable/Disable		CMPB1ENA	Enable	39
→B2.EN	Enable Compressor B2	Enable/Disable		CMPB2ENA	Enable	39
→CS.A1	CSB A1 Feedback Alarm	Enable/Disable		CSB_A1EN	Enable	39,101
→CS.A2	CSB A2 Feedback Alarm	Enable/Disable		CSB_A2EN	Enable	39,101
→CS.B1	CSB B1 Feedback Alarm	Enable/Disable		CSB_B1EN	Enable	39,101
→CS.B2	CSB B2 Feedback Alarm	Enable/Disable		CSB_B2EN	Enable	39,101
→REV.R	Rev Rotation Verified ?	Yes/No		REVR_VER	No	39,99
→H.SST	Hi SST Alert Delay Time	5 - 30	min	HSSTIME	10	39,98
<b>EDT.R</b>	<b>EVAP.DISCHRG TEMP RESET</b>					
→RS.CF	EDT Reset Configuration	0 - 3 (multi-text strings)		EDRSTCFG	0	28,38
→RTIO	Reset Ratio	0 - 10		RTIO	2	28,38
→LIMT	Reset Limit	0 - 20	^F	LIMT	10	28,38
→RES.S	EDT 4-20 ma Reset Input	Enable/Disable		EDTRSENS	Disable	28,35,38,97
<b>HEAT</b>	<b>HEATING CONFIGURATION</b>					
→HT.CF	Heating Control Type	0 - 4	dF	HEATTYPE	0	50,51,56,71
→HT.SP	Heating Supply Air Setpt	80 - 120		SASPHEAT	85	50,51
→OC.EN	Occupied Heating Enabled	Yes/No		HTOCCENA	No	51
→LAT.M	MBB Sensor Heat Relocate	Yes/No		HTLATMON	No	51
→G.FOD	Fan-Off Delay, Gas Heat	45-600		GAS_FOD	45	51
→E.FOD	Fan-Off Delay, Elec Heat	10-600		HEAT_FOD	30	51
→SG.CF	<b>STAGED GAS CONFIGS</b>					
→SG.CF→HT.ST	Staged Gas Heat Type	0 - 4		HTSTGTYP	0	51,53-56
→SG.CF→CAP.M	Max Cap Change per Cycle	5 - 45		HTCAPMAX	45	51,53,54
→SG.CF→M.R.DB	S.Gas DB min.dF/PID Rate	0 - 5		HT_MR_DB	0.5	51,53,54
→SG.CF→S.G.DB	St.Gas Temp. Dead Band	0 - 5	^F	HT_SG_DB	2	51,53,54
→SG.CF→RISE	Heat Rise dF/sec Clamp	0.05 - 0.2		HTSGRISE	0.06	51,53
→SG.CF→LAT.L	LAT Limit Config	0 - 20	^F	HTLATLIM	10	51,53
→SG.CF→LIM.M	Limit Switch Monitoring?	Yes/No		HTLIMMON	No	51,53
→SG.CF→SW.H.T	Limit Switch High Temp	110 - 180	dF	HT_LIMHI	170	51,53
→SG.CF→SW.L.T	Limit Switch Low Temp	100 - 170	dF	HT_LIMLO	160	51,53
→SG.CF→HT.P	Heat Control Prop. Gain	0 - 1.5		HT_PGAIN	1	51,53
→SG.CF→HT.D	Heat Control Derv. Gain	0 - 1.5		HT_DGAIN	1	51,53
→SG.CF→HT.TM	Heat PID Rate Config	60 - 300	sec	HTSGPIDR	90	51,53
<b>SP</b>	<b>SUPPLY STATIC PRESS.CFG.</b>					
→SP.CF	Static Pressure Config	0 - 1 (multi-text strings)		STATICCFG	No	31,57-60
→CV.FD	Constant Vol IDF is VFD?	Yes/No		CVIDFVFD	No	57,58
→SP.FN	Static Pres.Fan Control?	Yes		STATPFAN	Yes	57-59
→SP.S	Static Pressure Sensor	Enable/Disable		SPSENS	Disable	57-59
→SP.LO	Static Press. Low Range	-10 - 0		SP_LOW	0	58,59
→SP.HI	Static Press. High Range	0 - 10		SP_HIGH	5	58,59
→SP.SP	Static Pressure Setpoint	0 - 5	"H2O	SPSP	1.5	28,57-59
→SP.MN	VFD Minimum Speed	0 - 100	%	STATPMIN	20	58,59
→SP.MX	VFD Maximum Speed	0 - 100	%	STATPMAX	100	57-59
→SP.FS	VFD Fire Speed Override	0 - 100	%	STATPFSD	100	57-59,67
→HT.V.M	VFD Heating Min Speed	75-100	%	VFDHTMIN	75	57-59
→SP.RS	Stat. Pres. Reset Config	0-4 (multi-text strings)		SPRSTCFG	0	31,57-60
→SP.RT	SP Reset Ratio ("dF)	0 - 2.00		SPRRATIO	0.2	58,59
→SP.LM	SP Reset Limit in iwc(")	0 - 2.00		SPRLIMIT	0.75	58,59
→SP.EC	SP Reset Econo.Position	0 - 100	%	ECONOSPR	5	58,59
→S.PID	<b>STAT.PRESS.PID CONFIGS</b>					
→S.PID→SP.TM	Stat.Pres.PID Run Rate	1 - 200	sec	SPIDRATE	2	59
→S.PID→SP.P	Static Press. Prop. Gain	0 - 100		STATP_PG	20	59
→S.PID→SP.I	Static Pressure Intg. Gain	0 - 50		STATP_IG	2	59
→S.PID→SP.D	Static Pressure Derv. Gain	0 - 50		STATP_DG	0	59
→S.PID→SP.SG	Static Press.System Gain	0 - 50		STATP_SG	1	59
<b>ECON</b>	<b>ECONOMIZER CONFIGURATION</b>					
→EC.EN	Economizer Installed?	Yes/No		ECON_ENA	Yes	28,61,62
→EC.MN	Economizer Min.Position	0 - 100	%	ECONOMIN	5	28,61,62
→EC.MX	Economizer Max.Position	0 - 100	%	ECONOMAX	98	28,42,43,50,61,62
→E.TRM	Economzr Trim For SumZ ?	Yes/No		ECONTRIM	Yes	28,48,61,62
→E.SEL	Econ ChangeOver Select	0 - 3 (multi-text strings)		ECON_SEL	1	28,32,61,62
→OA.E.C	OA Enthalpy ChgOvr Selct	1 - 5 (multi-text strings)		OAEC_SEL	4	28,61,62
→OA.EN	Outdr.Enth Compare Value	18 - 28		OAEN_CFG	24	28,61,62
→OAT.L	High OAT Lockout Temp	-40 - 120	dF	OAT_LOCK	60	28,61,62
→O.DEW	OA Dewpoint Temp Limit	50 - 62	dF	OADEWCFG	55	28,62
→ORH.S	Outside Air RH Sensor	Enable/Disable		OARHSENS	Disable	28,61,62,98
→E.TYP	Economizer Control Type	1-3 (multi-text strings)		ECON_CTL	1	61,62
→EC.SW	Economizer Switch Config	0 - 2 (multi-text strings)		ECOSWCFG	0	61,62
→E.CFG	<b>ECON.OPERATION CONFIGS</b>					
→E.CFG→E.P.GN	Economizer Prop.Gain	0.7 - 3.0		EC_PGAIN	1	62
→E.CFG→E.RNG	Economizer Range Adjust	0.5 - 5.0	^F	EC_RANGE	2.5	62
→E.CFG→E.SPD	Economizer Speed Adjust	0.1 - 10.0		EC_SPEED	0.75	62
→E.CFG→E.DBD	Economizer Deadband	0.1 - 2.0	^F	EC_DBAND	0.5	62
→UEFC	<b>UNOCC.ECON.FREE COOLING</b>					
→UEFC→FC.CF	Unoc Econ Free Cool Cfg	0-2 (multi-text strings)		UEFC_CFG	0	62,63
→UEFC→FC.TM	Unoc Econ Free Cool Time	0 - 720	min	UEFCTIME	120	62,63
→UEFC→FC.L.O	Un.Ec.Free Cool OAT Lock	40 - 70	dF	UEFCNTLO	50	62,63

**APPENDIX A — LOCAL DISPLAY TABLES (cont)**

**MODE — CONFIGURATION (cont)**

ITEM	EXPANSION	RANGE	UNITS	CCN POINT	DEFAULT	PAGE NO.
<b>BP</b>	<b>BUILDING PRESS. CONFIG</b>					
→BP.CF	Building Press. Config	0-3		BLDG_CFG	0	29,64,66
→BP.RT	Bldg.Pres.PID Run Rate	5-120	sec	BPIDRATE	10	64,66
→BP.P	Bldg. Press. Prop. Gain	0-5		BLDGP_PG	0.5	64,66
→BP.I	Bldg.Press.Integ.Gain	0-2		BLDGP_IG	0.5	64,66
→BP.D	Bldg.Press.Deriv.Gain	0-5		BLDGP_DG	0.3	64,66
→BP.SO	BP Setpoint Offset	0.0 - 0.5	"H2O	BPSO	0.05	64,66
→BP.MN	BP VFD Minimum Speed	0-100	%	BLDGPMIN	10	64,66
→BP.MX	BP VFD Maximum Speed	0-100	%	BLDGPMAX	100	65,66
→BP.FS	VFD/Act. Fire Speed/Pos.	0-100	%	BLDGPFSD	100	65,66
→BP.MT	Power Exhaust Motors	1-2		PWRM	1	65,66
→BP.S	Building Pressure Sensor	Enable/Dsable		BPSENS	Dsable	65,66
→BP.R	Bldg Press (+/-) Range	0 - 1.00	"H2O	BP_RANGE	0.25	65,66
→BP.SP	Building Pressure Setp.	-0.25 -> 0.25	"H2O	BPSP	0.05	29,65,66
→BP.P1	Power Exhaust On Setp.1	0 - 100	%	PES1	35	29,65,66
→BP.P2	Power Exhaust On Setp.2	0 - 100	%	PES2	75	29,65,66
→B.CFG	<b>BP ALGORITHM CONFIGS</b>					65,66
→B.CFG→BP.SL	Modulating PE Alg. Slct.	1-3		BPSELECT	1	65,66
→B.CFG→BP.TM	BP PID Evaluation Time	0 - 10	min	BPPERIOD	1	65,66
→B.CFG→BP.ZG	BP Threshold Adjustment	0.1 - 10.0	"H2O	BPZ_GAIN	1	65,66
→B.CFG→BP.HP	High BP Level	0 - 1.000	"H2O	BPHPLVL	0.05	65,66
→B.CFG→BP.LP	Low BP Level	0 - 1.000	"H2O	BPLPLVL	0.04	65,66
<b>D.LV.T</b>	<b>COOL/HEAT SETPT. OFFSETS</b>					
→L.H.ON	Dmd Level Lo Heat On	-1 - 2	^F	DMDLHON	1.5	27,28,42,52
→H.H.ON	Dmd Level(+) Hi Heat On	0.5 - 20.0	^F	DMDHHON	0.5	27,28,42,52
→L.H.OF	Dmd Level(-) Lo Heat Off	0.5 - 2	^F	DMDLHOFF	1	27,28,42,52
→L.C.ON	Dmd Level Lo Cool On	-1 - 2	^F	DMDLCON	1.5	27,28,42,52
→H.C.ON	Dmd Level(+) Hi Cool On	0.5 - 20.0	^F	DMDHCON	0.5	27,28,42,52
→L.C.OF	Dmd Level(-) Lo Cool Off	0.5 - 2	^F	DMDLCOFF	1	27,28,42,52
→C.T.LV	Cool Trend Demand Level	0.1 - 5	^F	CTRENDLV	0.1	42,52
→H.T.LV	Heat Trend Demand Level	0.1 - 5	^F	HTRENDLV	0.1	42,52
→C.T.TM	Cool Trend Time	30 - 600	sec	CTRENDTM	120	42,52
→H.T.TM	Heat Trend Time	30 - 600	sec	HTRENDTM	120	42,52
<b>DMD.L</b>	<b>DEMAND LIMIT CONFIG.</b>					
→DM.L.S	Demand Limit Select	0 - 3 (multi-text strings)		DMD_CTRL	0	31,35,48,49,99
→D.L.20	Demand Limit at 20 ma	0 - 100	%	DMT20MA	100	31,49
→SH.NM	Loadshed Group Number	0 - 99		SHED_NUM	0	49
→SH.DL	Loadshed Demand Delta	0 - 60	%	SHED_DEL	0	49
→SH.TM	Maximum Loadshed Time	0 - 120	min	SHED_TIM	60	49
→D.L.S1	Demand Limit Sw.1 Setpt.	0 - 100	%	DLSWSP1	80	31,49
→D.L.S2	Demand Limit Sw.2 Setpt.	0 - 100	%	DLSWSP2	50	31,49
<b>IAQ</b>	<b>INDOOR AIR QUALITY CFG.</b>					
→DCV.C	<b>DCV ECONOMIZER SETPOINTS</b>					
→DCV.C→EC.MN	Economizer Min.Position	0 - 100	%	ECONOMIN	5	29,31,32,68-70
→DCV.C→IAQ.M	IAQ Demand Vent Min.Pos.	0 - 100	%	IAQMINP	0	29,31,68-70
→AQ.CF	<b>AIR QUALITY CONFIGS</b>					
→AQ.CF→IQ.A.C	IAQ Analog Sensor Config	0 - 4 (multi-text strings)		IAQANCFG	0	32,68-70
→AQ.CF→IQ.A.F	IAQ 4-20 ma Fan Config	0 - 2 (multi-text strings)		IAQANFAN	0	32,69,70
→AQ.CF→IQ.I.C	IAQ Discrete Input Config	0 - 2 (multi-text strings)		IAQINCFG	0	31,35,69-70
→AQ.CF→IQ.I.F	IAQ Disc.In. Fan Config	0 - 2 (multi-text strings)		IAQINFAN	0	32,69-70
→AQ.CF→OQ.A.C	OAQ 4-20ma Sensor Config	0 - 2 (multi-text strings)		OQANCFG	0	35,69-70
→AQ.SP	<b>AIR QUALITY SETPOINTS</b>					
→AQ.SP→IQ.O.P	IAQ Econ Override Pos.	0 - 100	%	IAQOVPOS	100	32,68-70,100
→AQ.SP→DAQ.L	Diff.Air Quality LoLimit	0 - 1000		DAQ_LOW	100	68-70
→AQ.SP→DAQ.H	Diff.Air Quality HiLimit	100 - 2000		DAQ_HIGH	700	32,68-70
→AQ.SP→D.F.OF	DAQ PPM Fan Off Setpoint	0 - 2000		DAQFNOFF	200	32,69,70
→AQ.SP→D.F.ON	DAQ PPM Fan On Setpoint	0 - 2000		DAQFNON	400	32,69,70
→AQ.SP→IAQ.R	Diff. AQ Responsiveness	-5 - 5		IAQREACT	0	68-70
→AQ.SP→OAQ.L	OAQ Lockout Value	0 - 2000		OAQLOCK	0	68-70
→AQ.SP→OAQ.U	User Determined OAQ	0 - 5000		OAQ_USER	400	32,68-70
→AQ.S.R	<b>AIR QUALITY SENSOR RANGE</b>					
→AQ.S.R→IQ.R.L	IAQ Low Reference	0 - 5000		IAQREFL	0	32,68-70
→AQ.S.R→IQ.R.H	IAQ High Reference	0 - 5000		IAQREFH	2000	32,68-70
→AQ.S.R→OQ.R.L	OAQ Low Reference	0 - 5000		OQREFL	0	68-70
→AQ.S.R→OQ.R.H	OAQ High Reference	0 - 5000		OQREFH	2000	68-70
→IAQ.P	<b>IAQ PRE-OCCUPIED PURGE</b>					
→IAQ.P→IQ.PG	IAQ Purge	Yes/No		IAQPURGE	No	69,70
→IAQ.P→IQ.P.T	IAQ Purge Duration	5-60	min	IAQPTIME	15	69,70
→IAQ.P→IQ.P.L	IAQ Purge LoTemp Min Pos	0-100	%	IAQPLTMP	10	69,70
→IAQ.P→IQ.P.H	IAQ Purge HiTemp Min Pos	0-100	%	IAQPHTMP	35	69,70
→IAQ.P→IQ.L.O	IAQ Purge OAT Lockout	35-70	dF	IAQPNTLO	50	69,70
<b>DEHU</b>	<b>DEHUMIDIFICATION CONFIG.</b>					
→D.SEL	Dehumidification Config	0-2 (multi-text strings)		DHSELECT	0	70,71
→D.SEN	Dehumidification Sensor	1-2 (multi-text strings)		DHSENSOR	1	70,71
→D.EC.D	Econ disable in DH mode?	Yes/No		DHECDISA	Yes	70,71
→D.V.CF	Vent Reheat Setpt Select	0-1 (multi-text strings)		DHVHTCFG	0	71
→D.V.RA	Vent Reheat RAT offset	0-8	^F	DHVRAOFF	0	71
→D.V.HT	Vent Reheat Setpoint	55-95	dF	DHVHT_SP	70	71
→D.C.SP	Dehumidify Cool Setpoint	40-55	dF	DHCOOLSP	45	71
→D.RH.S	Dehumidify RH Setpoint	10-90	%	DHRELHSP	55	71

**APPENDIX A — LOCAL DISPLAY TABLES (cont)**

**MODE — CONFIGURATION (cont)**

ITEM	EXPANSION	RANGE	UNITS	CCN POINT	DEFAULT	PAGE NO.
<b>CCN</b>	CCN CONFIGURATION					
→ <b>CCNA</b>	CCN Address	1 - 239		CCNADD	1	72
→ <b>CCNB</b>	CCN Bus Number	0 - 239		CCNBUS	0	72
→ <b>BAUD</b>	CCN Baud Rate	1 - 5 (multi-text strings)		CCNBAUDD	3	72
→ <b>BROD</b>	CCN BROADCAST DEFINITIONS					
→ <b>BROD</b> → <b>TM.DT</b>	CCN Time/Date Broadcast	ON/OFF		CCNBC	On	72
→ <b>BROD</b> → <b>OAT.B</b>	CCN OAT Broadcast	ON/OFF		OATBC	Off	72
→ <b>BROD</b> → <b>ORH.B</b>	CCN OARH Broadcast	ON/OFF		OARHBC	Off	72
→ <b>BROD</b> → <b>OAQ.B</b>	CCN OAQ Broadcast	ON/OFF		OAQBC	Off	72
→ <b>BROD</b> → <b>G.S.B</b>	Global Schedule Broadcast	ON/OFF		GSBC	Off	72
→ <b>BROD</b> → <b>B.ACK</b>	CCN Broadcast Ack'er	ON/OFF		CCNBCACK	Off	72
→ <b>SC.OV</b>	CCN SCHEDULES-OVERRIDES					
→ <b>SC.OV</b> → <b>SCH.N</b>	Schedule Number	0 - 99		SCHEDNUM	1	27-29,72
→ <b>SC.OV</b> → <b>HOL.T</b>	Accept Global Holidays?	YES/NO		HOLIDAYT	No	72
→ <b>SC.OV</b> → <b>O.T.L.</b>	Override Time Limit	0 - 4	HRS	OTL	1	27,72
→ <b>SC.OV</b> → <b>OV.EX</b>	Timed Override Hours	0 - 4	HRS	OVR_EXT	0	72,73
→ <b>SC.OV</b> → <b>SPT.O</b>	SPT Override Enabled ?	YES/NO		SPT_OVER	Yes	27,72,73
→ <b>SC.OV</b> → <b>T58.O</b>	T58 Override Enabled ?	YES/NO		T58_OVER	Yes	27,72,73
→ <b>SC.OV</b> → <b>GL.OV</b>	Global Sched. Override ?	YES/NO		GLBLOVER	No	72,73
<b>ALLM</b>	ALERT LIMIT CONFIG.					
→ <b>SPL.O</b>	SPT lo alert limit/occ	-10-245	dF	SPLO	60	73,74,100
→ <b>SP.H.O</b>	SPT hi alert limit/occ	-10-245	dF	SPHO	85	73,74,100
→ <b>SPL.U</b>	SPT lo alert limit/unocc	-10-245	dF	SPLU	45	73,74,100
→ <b>SP.H.U</b>	SPT hi alert limit/unocc	-10-245	dF	SPHU	100	73,74,100
→ <b>SA.L.O</b>	EDT lo alert limit/occ	-40-245	dF	SALO	40	43,73,74,100
→ <b>SA.H.O</b>	EDT hi alert limit/occ	-40-245	dF	SAHO	100	73,74,100
→ <b>SA.L.U</b>	EDT lo alert limit/unocc	-40-245	dF	SALU	40	73,74,100
→ <b>SA.H.U</b>	EDT hi alert limit/unocc	-40-245	dF	SAHU	100	73,74,100
→ <b>RA.L.O</b>	RAT lo alert limit/occ	-40-245	dF	RALO	60	73,74,100
→ <b>RA.H.O</b>	RAT hi alert limit/occ	-40-245	dF	RAHO	90	73,74,100
→ <b>RA.L.U</b>	RAT lo alert limit/unocc	-40-245	dF	RALU	40	73,74,100
→ <b>RA.H.U</b>	RAT hi alert limit/unocc	-40-245	dF	RAHU	100	73,74,100
→ <b>R.RH.L</b>	RARH low alert limit	0-100	%	RRHL	0	73,74,100
→ <b>R.RH.H</b>	RARH high alert limit	0-100	%	RRHH	100	73,74,100
→ <b>SPL</b>	SP low alert limit	0-5	"H2O	SPL	0	73,74,100
→ <b>SP.H</b>	SP high alert limit	0-5	"H2O	SPH	2	73,74,100
→ <b>BPL</b>	BP lo alert limit	-0.25-0.25	"H2O	BPL	-0.25	73,74,100
→ <b>BPH</b>	BP high alert limit	-0.25-0.25	"H2O	BPH	0.25	73,74,100
→ <b>IAQ.H</b>	IAQ high alert limit	0-5000		IAQH	1200	73,74,100
<b>TRIM</b>	SENSOR TRIM CONFIG.					
→ <b>SAT.T</b>	Air Temp Lvg SF Trim	-10 - 10	^F	SAT_TRIM	0	73,74
→ <b>RAT.T</b>	RAT Trim	-10 - 10	^F	RAT_TRIM	0	73,74
→ <b>OAT.T</b>	OAT Trim	-10 - 10	^F	OAT_TRIM	0	74
→ <b>SPT.T</b>	SPT Trim	-10 - 10	^F	SPT_TRIM	0	74
→ <b>CTA.T</b>	Cir A Sat.Cond.Temp Trim	-30 - 30	^F	SCTATRIM	0	74
→ <b>CTB.T</b>	Cir B Sat.Cond.Temp Trim	-30 - 30	^F	SCTBTRIM	0	74
→ <b>SPA.T</b>	Suct.Press.Circ.A Trim	-50 - 50	PSIG	SPA_TRIM	0	74
→ <b>SPB.T</b>	Suct.Press.Circ.B Trim	-50 - 50	PSIG	SPB_TRIM	0	74
→ <b>DPA.T</b>	Dis.Press.Circ.A Trim	-50 - 50	PSIG	DPA_TRIM	0	74
→ <b>DPB.T</b>	Dis.Press.Circ.B Trim	-50 - 50	PSIG	DPB_TRIM	0	74
<b>SW.LG</b>	SWITCH LOGIC: NO / NC					
→ <b>FTS.L</b>	Filter Status Inpt-Clean	Open/Close		FLTSLOGC	Open	74,75
→ <b>IGC.L</b>	IGC Feedback - Off	Open/Close		GASFANLG	Open	74,75
→ <b>RMI.L</b>	RemSw Off-Unoc-Strt-NoOv	Open/Close		RMTINLOG	Open	31,75,76
→ <b>ECS.L</b>	Economizer Switch - No	Open/Close		ECOSWLOG	Open	75,
→ <b>SFS.L</b>	Fan Status Sw. - Off	Open/Close		SFSLOGIC	Open	75,101
→ <b>DL1.L</b>	Dmd.Lmt.Sw.1 - Off	Open/Close		DMD_SW1L	Open	31,75
→ <b>DL2.L</b>	Dmd.Lmt.Sw.2 - Dehumid - Off	Open/Close		DMD_SW2L	Open	31,75
→ <b>IAQ.L</b>	IAQ Disc.Input - Low	Open/Close		IAQINLOG	Open	31,32,75
→ <b>FSD.L</b>	Fire Shutdown - Off	Open/Close		FSDLOGIC	Open	75,100
→ <b>PRS.L</b>	Pressurization Sw. - Off	Open/Close		PRESLOGC	Open	75
→ <b>EVC.L</b>	Evacuation Sw. - Off	Open/Close		EVACLOGC	Open	75
→ <b>PRG.L</b>	Smoke Purge Sw. - Off	Open/Close		PURGLOGC	Open	75
<b>DISP</b>	DISPLAY CONFIGURATION					
→ <b>TEST</b>	Test Display LEDs	ON/OFF		TEST	Off	75
→ <b>METR</b>	Metric Display	ON/OFF		DISPUNIT	Off	75
→ <b>LANG</b>	Language Selection	0-1(multi-text strings)		LANGUAGE	0	75
→ <b>PAS.E</b>	Password Enable	ENABLE/DISABLE		PASS_EBL	Enable	75
→ <b>PASS</b>	Service Password	0000-9999		PASSWORD	1111	75

**APPENDIX A — LOCAL DISPLAY TABLES (cont)**

**MODE — TIME CLOCK**

ITEM	EXPANSION	RANGE	UNITS	CCN POINT	DEFAULT	PAGE NO.
<b>TIME</b> → <b>HH.MM</b>	TIME OF DAY Hour and Minute	00:00		TIME		76,78
<b>DATE</b> → <b>MINTH</b> → <b>DOM</b> → <b>DAY</b> → <b>YEAR</b>	MONTH,DATE,DAY AND YEAR Month of Year Day of Month Day of Week Year	multi-text strings 0-31 multi-text strings e.g. 2003		MOY DOM DOWDISP YOCDISP		76,78 76,78 76,78 76,78
<b>SCH.L</b> → <b>PER.1</b> → <b>PER.1→DAYS</b> → <b>PER.1→DAYS→MON</b> → <b>PER.1→DAYS→TUE</b> → <b>PER.1→DAYS→WED</b> → <b>PER.1→DAYS→THU</b> → <b>PER.1→DAYS→FRI</b> → <b>PER.1→DAYS→SAT</b> → <b>PER.1→DAYS→SUN</b> → <b>PER.1→DAYS→HOL</b> → <b>PER.1→OCC</b> → <b>PER.1→UNC</b> <i>Repeated for periods 2-8.....</i>	LOCAL TIME SCHEDULE PERIOD 1 DAY FLAGS FOR PERIOD 1 Monday in Period Tuesday in Period Wednesday in Period Thursday in Period Friday in Period Saturday in Period Sunday in Period Holiday in Period Occupied from Occupied to	YES/NO YES/NO YES/NO YES/NO YES/NO YES/NO YES/NO YES/NO YES/NO 00:00 00:00		PER1MON PER1TUE PER1WED PER1THU PER1FRI PER1SAT PER1SUN PER1HOL PER1_OCC PER1_UNC	Period 1 only Yes Yes Yes Yes Yes Yes Yes Yes 00:00 24:00	27,28,76,78 76,78 76,78 76,78 77,78 77,78 77,78 77,78 77,78 77,78 77,78
<b>HOL.L</b> → <b>HD.01</b> → <b>HD.01→MON</b> → <b>HD.01→DAY</b> → <b>HD.01→LEN</b> <i>Repeated for holidays 2-30.....</i>	LOCAL HOLIDAY SCHEDULES HOLIDAY SCHEDULE 01 Holiday Start Month Start Day Duration (Days)	0-12 0-31 0-99		HOL_MON1 HOL_DAY1 HOL_LEN1		77,78 77,78 77,78
<b>DAY.S</b> <b>DS.ST</b> <b>DS.ST→ST.MN</b> <b>DS.ST→ST.WK</b> <b>DS.ST→ST.DY</b> <b>DS.ST→MIN.A</b> <b>DS.SP</b> <b>DS.SP→SP.MN</b> <b>DS.SP→SP.WK</b> <b>DS.SP→SP.DY</b> <b>DS.SP→MIN.S</b>	DAYLIGHT SAVINGS TIME DAYLIGHT SAVINGS START Month Week Day Minutes to Add DAYLIGHTS SAVINGS STOP Month Week Day Minutes to Subtract	1 - 12 1 - 5 1 - 7 0 - 90 1 - 12 1 - 5 1 - 7 0 - 90		STARTM STARTW STARTD MINADD STOPM STOPW STOPD MINSUB	4 1 7 60 10 5 7 60	77,78 77,78 77,78 77,78 77,78 77,78 77,78 77,78

**MODE — OPERATING MODES**

ITEM	EXPANSION	RANGE	UNITS	CCN POINT
<b>SYS.M</b> <b>HVAC</b> <b>CTRL</b> <b>MODE</b> → <b>OCC</b> → <b>T.OVR</b> → <b>DCV</b> → <b>SA.R</b> → <b>DMD.L</b> → <b>T.C.ST</b> → <b>IAQ.P</b> → <b>LINK</b> → <b>LOCK</b> → <b>H.NUM</b>	ascii string spelling out the system mode ascii string spelling out the hvac modes ascii string spelling out the "control type" MODES CONTROLLING UNIT Currently Occupied Timed Override in Effect DCV Resetting Min Pos Supply Air Reset Demand Limit in Effect Temp.Compensated Start IAQ Pre-Occ Purge Active Linkage Active - CCN Mech.Cooling Locked Out HVAC Mode Numerical Form	ON/OFF ON/OFF ON/OFF ON/OFF ON/OFF ON/OFF ON/OFF ON/OFF ON/OFF 0-24		string string string MODEOCCP MODETOVR MODEADCV MODESARCS MODEDMLT MODETCST MODEIQPG MODELINK MODELOCK MODEHVAC

**MODE — ALARMS**

ITEM	EXPANSION	RANGE	UNITS	CCN POINT	WRITE STATUS
<b>CURR</b> <b>R.CUR</b> <b>HIST</b>	CURRENTLY ACTIVE ALARMS this is a dynamic list of active alarms Reset All Current Alarms ALARM HISTORY this is a record of the last 20 alarms	YES/NO		strings ALRESET strings	ram config



## APPENDIX B — CCN TABLES

All A Series units with *ComfortLink* controls have a port for interface with the Carrier Comfort Network® (CCN) system. On TB3 there is a J11 jack which can be used for temporary connection to the CCN network or to computers equipped with CCN software like the Service Tool. Also on TB3 there are screw connections that can be used for more permanent CCN connections.

In the following tables the structure of the tables which are used with the Service Tool as well as the names and data that are included in each table are shown. As a reference the equivalent scrolling marquee tables and names are included. There are several CCN variables that are not displayed through the scrolling marquee and are used for more extensive diagnostics and system evaluations.

### STATUS DISPLAY TABLES

TABLE	DISPLAY NAME	RANGE	UNITS	POINT NAME	WRITE STATUS
COOLING	HVAC Mode.....: Control Mode.....:	ascii text strings ascii text strings			
	Current Running Capacity Cooling Control Point Evaporator Discharge Tmp Mixed Air Temperature		% dF dF dF	CAPTOTAL COOLCPNT EDT MAT	
COOL_A	Compressor A1 Relay Compressor A1 Feedback Compressor A1 Timeguard Compressor A2 Relay Compressor A2 Feedback Compressor A2 Timeguard Minimum Load Valve Cir A Discharge Pressure Cir A Suction Pressure Cir A Sat.Condensing Tmp Cir A Sat.Suction Temp.		PSIG PSIG dF dF	CMPA1 CSB_A1 CMPA1_TG CMPA2 CSB_A2 CMPA2_TG MLV DP_A SP_A SCTA SSTA	
COOL_B	Compressor B1 Relay Compressor B1 Feedback Compressor B1 Timeguard Compressor B2 Relay Compressor B2 Feedback Compressor B2 Timeguard Cir B Discharge Pressure Cir B Suction Pressure Cir B Sat.Condensing Tmp Cir B Sat.Suction Temp.		PSIG PSIG dF dF	CMPB1 CSB_B1 CMPB1_TG CMPB2 CSB_B2 CMPB2_TG DP_B SP_B SCTB SSTB	
ECONDIAG	Economizer Active ?	Yes/No		EACTIVE	
	Conditions which prevent economizer being active:				
	Econ Act. Unavailable?	Yes/No		ECONUNAV	
	Remote Econ. Disabled ?	Yes/No		ECONDISA	
	DBC - OAT lockout?	Yes/No		DBC_STAT	
	DEW - OA Dewpt. lockout?	Yes/No		DEW_STAT	
	DDBC- OAT > RAT lockout?	Yes/No		DDBCSTAT	
	OAEC- OA Enth Lockout?	Yes/No		OAECSTAT	
	DEC - Diff.Enth.Lockout?	Yes/No		DEC_STAT	
	EDT Sensor Bad ?	Yes/No		EDT_STAT	
	OAT Sensor Bad ?	Yes/No		OAT_STAT	
	Economizer forced ?	Yes/No		ECONFORC	
Supply Fan not on 30s ?	Yes/No		SFONSTAT		
Cool Mode not in effect?	Yes/No		COOL_OFF		
OAQ lockout in effect ?	Yes/No		OAQLOCKD		
Econ recovery hold off?	Yes/No		ECONHELD		
ECONOMZR	Economizer Act.Curr.Pos. Economizer Act.Cmd.Pos.		% %	ECONOPOS ECONOCMD	forcible
	Economizer Active ? Economizer Control Point		dF	EACTIVE ECONCPNT	
	Outside Air Temperature		dF	OAT	forcible
	Evaporator Discharge Tmp Controlling Return Temp		dF dF	EDT RETURN_T	forcible

**APPENDIX B — CCN TABLES (cont)**

**STATUS DISPLAY TABLES (cont)**

TABLE	DISPLAY NAME	RANGE	UNITS	POINT NAME	WRITE STATUS
GENERAL	Occupied ?	Yes/No		OCCUPIED	forcible
	Static Pressure		"H2O	SP	
	Building Pressure		"H2O	BP	
	Outside Air Rel.Humidity		%	OARH	forcible
	Return Air Rel.Humidity		%	RARH	forcible
	Space Temperature Offset		^F	SPTO	forcible
Supply Air Setpnt. Reset		^F	SASPRSET	forcible	
Static Pressure Reset			SPRESET	forcible	
IAQ - PPM Return CO2			IAQ	forcible	
OAQ - PPM Return CO2			OAQ	forcible	
IAQ Min.Pos.Override			IAQMINOV	forcible	
GENERIC	20 points dependent upon the configuration of the "generics" table in the Service-Config section on page 156.				
HEATING	HVAC Mode.....:	ascii text strings ascii text strings ascii text strings ascii text strings ascii text strings	dF	HT_STAGE HEATCPNT	forcible
	Control Mode.....:				
	Heat Control Type.....:				
	Re-Heat Control Type				
	Heating Mode.....:				
	Current Heat Stage				
	Heating Control Point				
	Heat Relay 1				
	Heat Relay 2				
	Relay 3 W1 Gas Valve 2				
	Relay 4 W2 Gas Valve 2				
	Relay 5 W1 Gas Valve 3				
Relay 6 W2 Gas Valve 3					
Heat Interlock Relay					
Heat Stage 1 Timeguard					
Heat Stage 2 Timeguard					
Heat Stage 3 Timeguard					
Heat Stage 4 Timeguard					
Heat Stage 5 Timeguard					
Heat Stage 6 Timeguard					
MODEDISP	System Mode.....: HVAC Mode.....: Control Mode.....: Currently Occupied Timed Override in effect DCV resetting min pos Supply Air Reset Demand Limit in Effect Temp.Compensated Start IAQ pre-occ purge active Linkage Active - DAV Mech.Cooling Locked Out HVAC Mode Numerical Form	ascii text strings ascii text strings ascii text strings On/Off On/Off On/Off On/Off On/Off On/Off On/Off On/Off On/Off On/Off number		MODEOCCP MODETOVR MODEADCV MODESARS MODEDMLT MODETCST MODEIQPG MODELINK MODELOCK MODEHVAC	
MODETRIP	Unoccup. Cool Mode Start Unoccup. Cool Mode End Occupied Cool Mode Start Occupied Cool Mode End  Ctl.Temp RAT,SPT or Zone  Occupied Heat Mode End Occupied Heat Mode Start Unoccup. Heat Mode End Unoccup. Heat Mode Start HVAC Mode.....:	ascii text strings		UCCLSTRT UCCL_END OCCLSTRT OCCL_END  CTRLTEMP  OCHT_END OCHTSTRT UCHT_END UCHTSTRT string	
TEMPCTRL	Evaporator Discharge Tmp Leaving Air Temperature Mixed Air Temperature Controlling Return Temp Controlling Space Temp		dF dF dF dF dF	EDT LAT MAT RETURN_T SPACE_T	forcible forcible

**APPENDIX B — CCN TABLES (cont)**

**STATUS DISPLAY TABLES (cont)**

TABLE	DISPLAY NAME	RANGE	UNITS	POINT NAME	WRITE STATUS
TEMPS	Air Temp Lvg Supply Fan		dF	SAT	
	Return Air Temperature		dF	RAT	forcible
	Outside Air Temperature		dF	OAT	forcible
	Space Temperature		dF	SPT	forcible
	Space Temperature Offset		^F	SPTO	forcible
	Staged Gas LAT Sum		dF	LAT_SGAS	
	Staged Gas LAT 1		dF	LAT1SGAS	
	Staged Gas LAT 2		dF	LAT2SGAS	
	Staged Gas LAT 3		dF	LAT23SGAS	
	Staged Gas Limit Sw.Temp		dF	LIMSWTMP	
	Cir A Sat.Condensing Tmp		dF	SCTA	
	Cir B Sat.Condensing Tmp		dF	SCTB	
	Cir A Sat.Suction Temp.		dF	SSTA	
	Cir B Sat.Suction Temp.		dF	SSTB	
	TSTAT	Control Mode.....:	ascii text strings		
Thermostat Y1 Input		On/Off		Y1	forcible
Thermostat Y2 Input		On/Off		Y2	forcible
Thermostat W1 Input		On/Off		W1	forcible
Thermostat W2 Input		On/Off		W2	forcible
Thermostat G Input		On/Off		G	forcible
UINPUTS	Filter Status Input	Dirty/Clean		FLTS	forcible
	Fan request from IGC	On/Off		IGCFAN	
	Fire Shutdown Switch	Alarm/Normal		FSD	forcible
	Thermostat G Input	On/Off		G	forcible
	Thermostat W2 Input	On/Off		W2	forcible
	Thermostat W1 Input	On/Off		W1	forcible
	Thermostat Y2 Input	On/Off		Y2	forcible
	Thermostat Y1 Input	On/Off		Y1	forcible
	Economizer Control Input	On/Off		ECOSW	forcible
	Remote Economizer Enable	Yes/No		ECONENBL	forcible
	Econo Position Override	Yes/No		ECOORIDE	forcible
	Remote Input State	On/Off		RMTIN	forcible
	Supply Fan Status Switch	On/Off		SFS	forcible
	Demand Limit Switch 1	On/Off		DMD_SW1	forcible
	Demand Limit Switch 2	On/Off		DMD_SW2	forcible
	Pressurization Input	Alarm/Normal		PRES	forcible
	Evacuation Input	Alarm/Normal		EVAC	forcible
Smoke Purge Input	Alarm/Normal		PURG	forcible	
IAQ - Discrete Input	High/Low		IAQIN	forcible	
Dehumidify Switch Input	On/Off		DHDISCIN	forcible	
UOUTPUTS	FANS				
	Supply Fan Relay	On/Off		SFAN_RLY	
	Supply Fan VFD Speed	0-100	%	SFAN_VFD	
	Supply Fan Request	Yes/No		SFANFORC	forcible
	Power Exhaust Relay A	On/Off		PE_A	
	Power Exhaust Relay B	On/Off		PE_B	
	Power Exhaust Relay C	On/Off		PE_C	
	Condenser Fan A	On/Off		CONDFANA	
	Condenser Fan B	On/Off		CONDFANB	
	COOLING				
	Compressor A1 Relay	On/Off		CMPA1	
	Compressor A2 Relay	On/Off		CMPA2	
	Minimum Load Valve	On/Off		MLV	
	Compressor B1 Relay	On/Off		CMPB1	
	Compressor B2 Relay	On/Off		CMPB2	
	HEATING				
	Heat Relay 1	On/Off		HS1	
	Heat Relay 2	On/Off		HS2	
	Relay 3 W1 Gas Valve 2	On/Off		HS3	
	Relay 4 W2 Gas Valve 2	On/Off		HS4	
Relay 5 W1 Gas Valve 3	On/Off		HS5		
Relay 6 W2 Gas Valve 3	On/Off		HS6		
Heat Interlock Relay	On/Off		HIR	forcible	
ECONOMIZER					
Economizer Act.Curr.Pos.	0-100	%	ECONOPOS		
Economizer Act.Cmd.Pos.	0-100	%	ECONOCMD	forcible	
Economizer Power Relay	On/Off		ECON_PWR	forcible	
GENERAL OUTPUTS					
Remote Alarm/Aux Relay	On/Off		ALRM	forcible	

**APPENDIX B — CCN TABLES (cont)**

**SET POINT TABLE**

TABLE	NAME	RANGE	UNITS	POINT NAME	DEFAULT
SET_PNT	Occupied Heat Setpoint	40-99	dF	OHSP	68
	Occupied Cool Setpoint	40-99	dF	OCSP	75
	Unoccupied Heat Setpoint	40-99	dF	UHSP	55
	Unoccupied Cool Setpoint	40-99	dF	UCSP	90
	Heat-Cool Setpoint Gap	2-10	^F	HCSP_GAP	5
	VAV Occ. Cool On Delta	0-25	^F	VAVOCON	3.5
	VAV Occ. Cool Off Delta	1-25	^F	VAVOCOFF	2
	Supply Air Setpoint	45-75	dF	SASP	55
	Supply Air Setpoint Hi	45-75	dF	SASP_HI	55
	Supply Air Setpoint Lo	45-75	dF	SASP_LO	60
	Heating Supply Air Setpt	80-100	dF	SASPHEAT	85
	Tempering Purge SASP	-20-80	dF	TEMPPURG	50
	Tempering in Cool SASP	5-75	dF	TEMPCOOL	5
	Tempering in Vent Occ SASP	-20-80	dF	TEMPVOCC	65
	Tempering Vent Unocc. SASP	-20-80	dF	TEMPVUNC	50

**CONFIG TABLES**

TABLE	NAME	RANGE	UNITS	POINT NAME	DEFAULT
ALARMDEF	Alarm Routing Control	00000000-11111111		ALRM_CNT	11000000
	Equipment Priority	0 - 7		EQP_TYPE	5
	Comm Failure Retry Time	1 - 240	min	RETRY_TM	10
	Re-Alarm Time	1 - 255	min	RE-ALARM	30
	Alarm System Name	up to 8 alphanum		ALRM_NAM	A-SERIES
BRODEFS	CCN Time/Date Broadcast	Off/On		CCNBC	Off
	CCN OAT Broadcast	Off/On		OATBC	Off
	CCN OARH Broadcast	Off/On		OARHBC	Off
	CCN OAQ Broadcast	Off/On		OAQBC	Off
	Global Schedule Broadcast	Off/On		GSBC	Off
	Daylight Savings Start:				
	Month	1 - 12		STARTM	4
	Week	1 - 5		STARTW	1
	Day	1 - 7		STARTD	7
	Minutes to Add	0 - 90		MINADD	60
	Daylight Savings Stop:				
	Month	1 - 12		STOPM	10
	Week	1 - 5		STOPW	5
	Day	1 - 7		STOPD	7
Minutes to Subtract	0 - 90		MINSUB	60	
Ctrl-ID	Device Name: Description: Location: Software Part Number: Model Number: Serial Number: Reference Number:	A-Series A Series Rooftop  CESR131343-XX-XX			
HOLIDAY HOLDY01S to HOLDY30S	Broadcast Supervisory				
	Holiday Start Month	1-12		HOL-MON	0
	Start Day	1-31		HOL-DAY	0
Duration (days)	1-99		HOL-LEN	0	
OCCDEFCS	Occupancy Supervisory				
	Timed Override Hours	0		OVR-EXT	
	Period 1 DOW (MTWTFSSH)	00000000		DOW1	
	Occupied From	0:00		OCCTOD1	
	Occupied To	0:00		UNOCTOD1	
	Period 2 DOW (MTWTFSSH)	00000000		DOW2	
	Occupied From	0:00		OCCTOD2	
	Occupied To	0:00		UNOCTOD2	
	Period 3 DOW (MTWTFSSH)	00000000		DOW3	
	Occupied From	0:00		OCCTOD3	
	Occupied To	0:00		UNOCTOD3	
	Period 4 DOW (MTWTFSSH)	00000000		DOW4	
	Occupied From	0:00		OCCTOD4	
	Occupied To	0:00		UNOCTOD4	
	Period 5 DOW (MTWTFSSH)	00000000		DOW5	
	Occupied From	0:00		OCCTOD5	
	Occupied To	0:00		UNOCTOD5	
	Period 6 DOW (MTWTFSSH)	00000000		DOW6	
	Occupied From	0:00		OCCTOD6	
	Occupied To	0:00		UNOCTOD6	
	Period 7 DOW (MTWTFSSH)	00000000		DOW7	
	Occupied From	0:00		OCCTOD7	
	Occupied To	0:00		UNOCTOD7	
	Period 8 DOW (MTWTFSSH)	00000000		DOW8	
Occupied From	0:00		OCCTOD8		
Occupied To	0:00		UNOCTOD8		

**APPENDIX B — CCN TABLES (cont)**

**CONFIG TABLES (cont)**

TABLE	NAME	RANGE	UNITS	POINT NAME	DEFAULT
SCHEDOVR	Schedule Number	0-99		SCHEDNUM	0
	Accept Global Holidays?	Yes/No		HOLIDAYT	No
	Override Time Limit	0-4	hours	OTL	1
	Timed Override Hours	0-4	hours	OVR_EXT	0
	Accepting an Override: SPT Override Enabled ?	Yes/No		SPT_OVER	Yes
	T58 Override Enabled ?	Yes/No		T58_OVER	Yes
	Allowed to Broadcast a Global Sched. Override ?	Yes/No		GLBLOVER	No
SET_PNT	Occupied Heat Setpoint	55-80	dF	OHSP	68
	Occupied Cool Setpoint	55-80	dF	OCSP	75
	Unoccupied Heat Setpoint	40-80	dF	UHSP	55
	Unoccupied Cool Setpoint	75-95	dF	UCSP	90
	Heat-Cool Setpoint Gap	2-10	^F	HCSP_GAP	5
	VAV Occ. Cool On Delta	0-25	^F	VAVOCON	3.5
	VAV Occ. Cool Off Delta	1-25	^F	VAVOCOFF	2
	Supply Air Setpoint	45-75	dF	SASP	55
	Supply Air Setpoint Hi	45-75	dF	SASP_HI	55
	Supply Air Setpoint Lo	45-75	dF	SASP_LO	60
	Heating Supply Air Setpt	90-145	dF	SASPHEAT	85
	Tempering Purge SASP	-20-80	dF	TEMPPURG	50

**SERVICE-CONFIG TABLES**

TABLE	NAME	RANGE	UNITS	POINT NAME	DEFAULT
ALLM	SPT lo alert limit/occ	-10-245	dF	SPLO	60
	SPT hi alert limit/occ	-10-245	dF	SPHO	85
	SPT lo alert limit/unocc	-10-245	dF	SPLU	45
	SPT hi alert limit/unocc	-10-245	dF	SPHU	100
	EDT lo alert limit/occ	-40-245	dF	SALO	40
	EDT hi alert limit/occ	-40-245	dF	SAHO	100
	EDT lo alert limit/unocc	-40-245	dF	SALU	40
	EDT hi alert limit/unocc	-40-245	dF	SAHU	100
	RAT lo alert limit/occ	-40-245	dF	RALO	60
	RAT hi alert limit/occ	-40-245	dF	RAHO	90
	RAT lo alert limit/unocc	-40-245	dF	RALU	40
	RAT hi alert limit/unocc	-40-245	dF	RAHU	100
	RARH low alert limit	0-100	%	RRHL	0
	RARH high alert limit	0-100	%	RRHH	100
	SP low alert limit	0-5	"H2O	SPL	0
	SP high alert limit	0-5	"H2O	SPH	2
	BP lo alert limit	-0.25-0.25	"H2O	BPL	-0.25
	BP high alert limit	-0.25-0.25	"H2O	BPH	0.25
	IAQ high alert limit	0-5000		IAQH	1200
BP__	Building Press. Config	0-3		BLDG_CFG	0
	Bldg.Pres.PID Run Rate	5-120		BPIDRATE	10
	Bldg. Press. Prop. Gain	0-5		BLDGP_PG	0.5
	Bldg.Press.Integ.Gain	0-2		BLDGP_IG	0.5
	Bldg.Press.Deriv.Gain	0-5		BLDGP_DG	0.3
	BP Setpoint Offset	0.0 - 0.5		BPSO	0.05
	BP VFD Minimum Speed	0-100		BLDGPMIN	10
	BP VFD Maximum Speed	0-100		BLDGPMAX	100
	VFD/Act. Fire Speed/Pos.	0-100		BLDGPFSO	100
	Power Exhaust Motors 0=None,1=4 Mtr, 2=6 Mtr	0-2		PWRM	1
	Building Pressure Sensor	Enable/Disable		BPSENS	Dsable
	Bldg Press (+/-) Range	0-1		BP_RANGE	0.25
	Building Pressure Setp.	-0.25 -> 0.25	"H2O	BPSP	0.05
	Power Exhaust On Setp.1	0-100	%	PES1	35
	Power Exhaust On Setp.2	0-100	%	PES2	75
	Modulating PE Alg. Slct.	1-3		BPSELECT	1
	BP PID Evaluation Time	0-10	min	BPPERIOD	1
	BP Threshold Adjustment	0.1-10		BPZ_GAIN	1
	High BP Level	0-1		BPHPLVL	0.05
	Low BP Level	0-1		BPLPLVL	0.04

**APPENDIX B — CCN TABLES (cont)**  
**SERVICE-CONFIG TABLES (cont)**

TABLE	NAME	RANGE	UNITS	POINT NAME	DEFAULT
COOL	Capacity Threshold Adjust	-10 -> 10		Z_GAIN	1
	Compressor Lockout Temp	-20 -> 55	dF	OATLCOMP	40
	Fan-off Delay, Mech Cool	0-600	sec	COOL_FOD	60
	Minimum Load Valve?	Yes/No		MLV_SEL	No
	Motor Master Control ?	Yes/No		MOTRMAST	No
	Head Pressure Setpoint	80-150	dF	HPSP	110
	Enable Compressor A1	Enable/Disable		CMPA1ENA	Enable
	Enable Compressor A2	Enable/Disable		CMPA2ENA	Enable
	Enable Compressor B1	Enable/Disable		CMPB1ENA	Enable
	Enable Compressor B2	Enable/Disable		CMPB2ENA	Enable
	CSB A1 Feedback Alarm	Enable/Disable		CSB_A1EN	Enable
	CSB A2 Feedback Alarm	Enable/Disable		CSB_A2EN	Enable
	CSB B1 Feedback Alarm	Enable/Disable		CSB_B1EN	Enable
	CSB B2 Feedback Alarm	Enable/Disable		CSB_B2EN	Enable
	Rev. Rotation Verified ?	Yes/No		REVR_VER	No
	Hi SST Alert Delay Time	5-30	min	HSSTTIME	10
DEHU	Dehumidification Config	0-2		DHSELECT	0
	Dehumidification Sensor	1-2		DHSENSOR	1
	Econ disable in DH mode?	Yes/No		DHECONEN	No
	Vent Reheat Setpt Select	0-1		DHVHTCFG	0
	Vent Reheat RAT offset	0-8	^F	DHVRAOFF	0
	Vent Reheat Setpoint	55-95	dF	DHVHT_SP	70
	Dehumidify Cool Setpoint	40-55	dF	DHCOOLSP	45
	Dehumidify RH Setpoint	10-90	%	DHRELHSP	55
DISP	Metric Display	Off/On		DISPUNIT	Off
	Language Selection	0-1		LANGUAGE	0
	Password Enable	Enable/Disable		PASS_EBL	Enable
	Service Password	0000-9999		PASSWORD	1111
	Contrast Adjustment	-255 - 255		CNTR_ADJ	0
DLVT	Brightness Adjustment	-255 - 255		BRTS_ADJ	0
	Dmd Level Lo Heat On	-1 - 2	^F	DMDLHON	1.5
DMDL	Dmd Level(+) Hi Heat On	0.5 - 20.0	^F	DMDHHON	0.5
	Dmd Level(-) Lo Heat Off	0.5 - 2	^F	DMDLHOFF	1
	Dmd Level Lo Cool On	-1 - 2	^F	DMDLCON	1.5
	Dmd Level(+) Hi Cool On	0.5 - 20.0	^F	DMDHCON	0.5
	Dmd Level(-) Lo Cool Off	0.5 - 2	^F	DMDLCOFF	1
	Cool Trend Demand Level	0.1 - 5	^F	CTRENDLV	0.1
	Heat Trend Demand Level	0.1 - 5	^F	HTRENDLV	0.1
	Cool Trend Time	30 - 600	sec	CTRENDTM	120
	Heat Trend Time	30 - 600	sec	HTRENDTM	120
	Demand Limit Select	0 - 3		DMD_CTRL	0
	Demand Limit at 20 ma	0 - 100	%	DMT20MA	100
	Loadshed Group Number	0 - 99		SHED_NUM	0
	Loadshed Demand Delta	0 - 60	%	SHED_DEL	0
	Maximum Loadshed Time	0 - 120	min	SHED_TIM	60
Demand Limit Sw.1 Setpt.	0 - 100	%	DLSWSP1	80	
Demand Limit Sw.2 Setpt.	0 - 100	%	DLSWSP2	50	
ECON	Economizer Installed ?	Yes/No		ECON_ENA	Yes
	Economizer Min.Position	0 - 100	%	ECONOMIN	20
	Economizer Max.Position	0 - 100	%	ECONOMAX	98
	Economizr trim for sumZ ?	Yes/No		ECONTRIM	Yes
	Econ ChangeOver Select	0 - 3		ECON_SEL	1
	OA Enthalpy ChgOvr Selct	1 - 5		OAEC_SEL	2
	Outdr.Enth Compare Value	18 - 28		OAEN_CFG	24
	High OAT Lockout Temp	55 - 120	dF	OAT_LOCK	60
	OA Dewpoint Temp Limit	50 - 62	dF	OADEWCFG	55
	Outside Air RH Sensor	Enable/Disable		OARHSENS	Disable
	Economizer Control Type	1-3		ECON_CTL	1
	Economizer Switch Config	0-2		ECOSWCFG	0
	Economizer Prop.Gain	0.7 - 3.0		EC_PGAIN	1
	Economizer Range Adjust	0.5 - 5	^F	EC_RANGE	2.5
	Economizer Speed Adjust	0.1 - 10	^F	EC_SPEED	0.75
	Economizer Deadband	0.1 - 2	^F	EC_DBAND	0.5
	Unoc Econ Free Cool Cfg	0-2		UEFC_CFG	0
	Unoc Econ Free Cool Time	0-720	min	UEFCTIME	120
Un.Ec.Free Cool OAT Lock	40-70	dF	UEFCNTLO	50	
EDTR	EDT Reset Configuration	0 - 3		EDRSTCFG	0
	Reset Ratio	0 - 10		RTIO	2
	Reset Limit	0 - 20	^F	LIMIT	10
	EDT 4-20 ma Reset Input	Enable/Disable		EDTRSENS	Disable

**APPENDIX B — CCN TABLES (cont)**

**SERVICE-CONFIG TABLES (cont)**

TABLE	NAME	RANGE	UNITS	POINT NAME	DEFAULT
HEAT	Heating Control Type	0 - 4		HEATTYPE	0
	Heating Supply Air Setpt	80-120	dF	SASPHEAT	85
	Occupied Heating Enabled	Yes/No		HTOCCENA	No
	MBB Sensor Heat Relocate	Yes/No		HTLATMON	No
	Fan-off Delay, Gas Heat	45-600		GAS_FOD	45
	Fan-off Delay, Elec Heat	10-600		ELEC_FOD	30
	Staged Gas Heat Type	0 - 4		HTSTGTYP	0
	Max Cap Change per Cycle	5 - 45		HTCAPMAX	45
	S.Gas DB min.dF/PID Rate	0 - 5		HT_MR_DB	0.5
	St.Gas Temp. Dead Band	0 - 5	^F	HT_SG_DB	2
	Heat Rise dF/sec Clamp	0.05 - 0.2		HTSGRISE	0.06
	LAT Limit Config	0 - 20	^F	HTLATLIM	10
	Heat Control Prop. Gain	0 - 1.5		HT_PGAIN	1
	Heat Control Derv. Gain	0 - 1.5		HT_DGAIN	1
	Heat PID Rate Config	60 - 300	sec	HTSGPIDR	90
IAQ_	Economizer Min.Position	0 - 100	%	ECONOMIN	5
	IAQ Demand Vent Min.Pos.	0 - 100	%	IAQMINP	0
	IAQ Analog Sensor Config	0 - 4		IAQANCFG	0
	IAQ 4-20 ma Fan Config	0 - 2		IAQANFAN	0
	IAQ Discrete Input Config	0 - 2		IAQINCFG	0
	IAQ Disc.In. Fan Config	0 - 2		IAQINFAN	0
	OAQ 4-20ma Sensor Config	0 - 2		OAQANCFG	0
	IAQ Econo Override Pos.	0 - 100	%	IAQOVPOS	100
	Diff. Air Quality LoLimit	0 - 1000		DAQ_LOW	100
	Diff. Air Quality HiLimit	100 - 2000		DAQ_HIGH	700
	DAQ PPM Fan Off Setpoint	0 - 2000		DAQFNOFF	200
	DAQ PPM Fan On Setpoint	0 - 2000		DAQFNON	400
	Diff. AQ Responsiveness	-5 - 5		IAQREACT	0
	OAQ Lockout Value	0 - 2000		OAQLOCK	0
	User determined OAQ	0-5000		OAQ_USER	400
	IAQ Low Reference	0 - 5000		IAQREFL	0
	IAQ High Reference	0 - 5000		IAQREFH	2000
	OAQ Low Reference	0 - 5000		OAQREFL	0
	OAQ High Reference	0 - 5000		OAQREFH	2000
	IAQ Purge	Yes/No		IAQPURGE	No
IAQ Purge Duration	5-60	min	IAQPTIME	15	
IAQ Purge LoTemp Min Pos	0-100	%	IAQPLTMP	10	
IAQ Purge HiTemp Min Pos	0-100	%	IAQPHTMP	35	
IAQ Purge OAT Lockout	35-70	dF	IAQPNTLO	50	
SP_	Static Pres.VFD Control?	No		STATICCFG	No
	Constant Vol IDF is VFD?	Yes/No		CVIDFVFD	No
	Static Pres.Fan Control?	Yes		STATPFAN	Yes
	Static Pressure Sensor	Enable/Disable		SPSENS	Disable
	Static Press. Low Range	-10 - 0		SP_LOW	0
	Static Press. High Range	0 - 10		SP_HIGH	5
	Static Pressure Setpoint	0 - 5	"H2O	SPSP	1.5
	VFD Minimum Speed	10 - 50	%	STATPMIN	20
	VFD Maximum Speed	50 - 100	%	STATPMAX	100
	VFD Fire Speed Override	0 - 100	%	STATPFSO	100
	VFD Heating Min Speed	75-100	%	VFDHTMIN	75
	Stat. Pres. Reset Config	0-4 (multi-text strings)		SPRSTCFG	0
	SP Reset Ratio ("/dF)	0 - 2.00		SPRRATIO	0.2
	SP Reset Limit in iwC(")	0 - 2.00		SPRLIMIT	0.75
	SP Reset Econo.Position	0 - 100	%	ECONOSPR	5
	Stat.Pres.PID Run Rate	1 - 200	sec	SPIDRATE	2
	Static Press. Prop. Gain	0 - 100		STATP_PG	20
	Static Pressure Intg. Gain	0 - 50		STATP_IG	2
Static Pressure Derv. Gain	0 - 50		STATP_DG	0	
Static Press.System Gain	0 - 50		STATP_SG	1	
TRIM	Air Temp Lvg SF Trim	-10 - 10	^F	SAT_TRIM	0
	RAT Trim	-10 - 10	^F	RAT_TRIM	0
	OAT Trim	-10 - 10	^F	OAT_TRIM	0
	SPT Trim	-10 - 10	^F	SPT_TRIM	0
	Cir A Sat.Cond.Temp Trim	-30 - 30	^F	SCTATRIM	0
	Cir B Sat.Cond.Temp Trim	-30 - 30	^F	SCTBTRIM	0
	Suct.Press.Circ.A Trim	-50 - 50	PSI	SPA_TRIM	0
	Suct.Press.Circ.B Trim	-50 - 50	PSI	SPB_TRIM	0
	Dis.Press.Circ.A Trim	-50 - 50	PSI	DPA_TRIM	0
	Dis.Press.Circ.B Trim	-50 - 50	PSI	DPB_TRIM	0
	Static Press. Trim (ma)	-2 - 2		SPMATRIM	0
	Bldg. Pressure Trim (ma)	-2 - 2		BPMATRIM	0

**APPENDIX B — CCN TABLES (cont)**

**SERVICE-CONFIG TABLES (cont)**

TABLE	NAME	RANGE	UNITS	POINT NAME	DEFAULT
<b>SWLG</b>	Filter Status Inpt-Clean	Open/Close		FLTSLOGC	Open
	IGC Feedback - Off	Open/Close		GASFANLG	Open
	RemSw Off-Unoc-Strt-NoOv	Open/Close		RMTINLOG	Open
	Economizer Switch - No	Open/Close		ECOSWLOG	Open
	Fan Status Sw. - Off	Open/Close		SFSLOGIC	Open
	Dmd.Lmt.Sw.1 - Off	Open/Close		DMD_SW1L	Open
	Dmd.Lmt.-Dehumid - Off	Open/Close		DMD_SW2L	Open
	IAQ Disc.Input - Low	Open/Close		IAQINLOG	Open
	Fire Shutdown - Off	Open/Close		FSDLOGIC	Open
	Press. Switch - Off	Open/Close		PRESLOGC	Open
	Evacuation Sw. - Off	Open/Close		EVACLOGC	Open
	Smoke Purge Sw. - Off	Open/Close		PURGLOGC	Open
<b>UNIT</b>	Machine Control Type	1-6		CTRLTYPE	4
	Fan Mode (0=auto, 1=cont)	0-1		FAN_MODE	1
	Remote Switch Config	0 -3		RMTINCFG	0
	CEM Module installed	Yes/No		CEM_BRD	No
	Temp.Cmp.Strt.Cool Factr	0-60	min	TCSTCOOL	0
	Temp.Cmp.Strt.Heat Factr	0-60	min	TCSTHEAT	0
	Fan fail shuts down unit	Yes/No		SFS_SHUT	No
	Fan Stat Monitoring Type	0-2		SFS_MON	0
	VAV Unocc.Fan Retry time	0-720	min	SAMPMINS	50
	Unit Size (20-60)	20-60	TONS	UNITSIZE	20
	20,25,27,30,35,40,50,60				
	Disch. Press. Transducer	Yes/No		DP_TRANS	No
	Suct. Pres. Trans. Type	0-1		SPXRTYPE	0
	Refrig: 0=R22 1=R410A	0-1		REFRIG_T	
	Cnd HX Typ:0=RTPF 1=MCHX	0-1		COILTYPE	
	MAT Calc Config	0-2		MAT_SEL	1
	Reset MAT Table Entries?	Yes/No		MATRESET	No
	MAT Outside Air Default	0-100	%	MATOAPOS	20
	Altitude.....in feet:	0-60000		ALTITUDE	0
	Startup Delay Time	0-900	sec	DELAY	0
	TSTAT-Both Heat and Cool	Yes/No		TSTATALL	No
	Auxiliary Relay Config	0 - 3		AUXRELAY	0
	Space Temp Sensor	Enable/Disable		SPTSENS	Disable
	Space Temp Offset Sensor	Enable/Disable		SPTOSENS	Disable
	Space Temp Offset Range	1 - 10	^F	SPTO_RNG	5
	Return Air RH Sensor	Enable/Disable		RARHSENS	Disable
Filter Stat.Sw.Enabled ?	Enable/Disable		FLTS_ENA	Disable	
<b>generics</b>	POINT_01 Definition	8 CHAR ASCII		POINT_01	
	POINT_02 Definition	8 CHAR ASCII		POINT_02	
	POINT_03 Definition	8 CHAR ASCII		POINT_03	
	POINT_04 Definition	8 CHAR ASCII		POINT_04	
	POINT_05 Definition	8 CHAR ASCII		POINT_05	
	POINT_06 Definition	8 CHAR ASCII		POINT_06	
	POINT_07 Definition	8 CHAR ASCII		POINT_07	
	POINT_08 Definition	8 CHAR ASCII		POINT_08	
	POINT_09 Definition	8 CHAR ASCII		POINT_09	
	POINT_10 Definition	8 CHAR ASCII		POINT_10	
	POINT_11 Definition	8 CHAR ASCII		POINT_11	
	POINT_12 Definition	8 CHAR ASCII		POINT_12	
	POINT_13 Definition	8 CHAR ASCII		POINT_13	
	POINT_14 Definition	8 CHAR ASCII		POINT_14	
	POINT_15 Definition	8 CHAR ASCII		POINT_15	
	POINT_16 Definition	8 CHAR ASCII		POINT_16	
	POINT_17 Definition	8 CHAR ASCII		POINT_17	
	POINT_18 Definition	8 CHAR ASCII		POINT_18	
	POINT_19 Definition	8 CHAR ASCII		POINT_19	
	POINT_20 Definition	8 CHAR ASCII		POINT_20	



**APPENDIX B — CCN TABLES (cont)**  
**MAINTENANCE DISPLAY TABLES**

TABLE	DISPLAY NAME	RANGE	UNITS	POINT NAME	WRITE STATUS	
<b>ALARMS01</b>	Active Alarm -----	ascii ascii		ALARM_01		
	Active Alarm -----	ascii ascii		ALARM_02		
	Active Alarm -----	ascii ascii		ALARM_03		
	Active Alarm -----	ascii ascii		ALARM_04		
<b>follow same format for...</b> <b>ALARMS02</b> <b>ALARMS03</b> <b>ALARMS04</b> <b>ALARMS05</b>						
<b>COMPRESR</b>	Compressor A1 Relay Compressor A1 Feedback Curr.Sens.Brd. A1 Status CSB A1 Feedback Alarm Comp A1 Locked Out ? Compressor A1 Strikes Enable Compressor A1	On/Off On/Off ascii Enable/Disable Yes/No Enable/Disable		CMPA1 CSB_A1 CSBA1ASC CSB_A1EN CMPA1LOK CMPA1STR CMPA1ENA	config     config	
	Compressor A2 Relay Compressor A2 Feedback Curr.Sens.Brd. A2 Status CSB A2 Feedback Alarm Comp A2 Locked Out ? Compressor A2 Strikes Enable Compressor A2	On/Off On/Off ascii Enable/Disable Yes/No Enable/Disable		CMPA2 CSB_A2 CSBA2ASC CSB_A2EN CMPA2LOK CMPA2STR CMPA2ENA	config     config	
	Compressor B1 Relay Compressor B1 Feedback Curr.Sens.Brd. B1 Status CSB B1 Feedback Alarm Comp B1 Locked Out ? Compressor B1 Strikes Enable Compressor B1	On/Off On/Off ascii Enable/Disable Yes/No Enable/Disable		CMPB1 CSB_B1 CSBB1ASC CSB_B1EN CMPB1LOK CMPB1STR CMPB1ENA	config     config	
	Compressor B2 Relay Compressor B2 Feedback Curr.Sens.Brd. B2 Status CSB B2 Feedback Alarm Comp B2 Locked Out ? Compressor B2 Strikes Enable Compressor B2	On/Off On/Off ascii Enable/Disable Yes/No Enable/Disable		CMPB2 CSB_B2 CSBB2ASC CSB_B2EN CMPB2LOK CMPB2STR CMPB2ENA	config     config	
	<b>DMANDLIM</b>	Active Demand Limit Percent Total Capacity	0-100 0-100	% %	DEM_LIM CAPTOTAL	forcible
		Demand Limit Select	0-3		DMD_CTRL	config
		Demand Limit Switch 1 Demand Limit Switch 2 Demand Limit Sw.1 Setpt. Demand Limit Sw.2 Setpt.	On/Off On/Off 0-100 0-100	  % %	DMD_SW1 DMD_SW2 DLSWSP1 DLSWSP2	forcible forcible config config
		4-20 ma Demand Signal Demand Limit at 20 ma	4-20 0-100	ma %	DMDLMTMA DMT20MA	forcible config
		CCN Loadshed Signal Loadshed Group Number Loadshed Demand Delta Maximum Loadshed Time	0-99 0-99 0-60 0-120	  % min	DL_STAT SHED_NUM SHED_DEL SHED_TIM	config config config config



**APPENDIX B — CCN TABLES (cont)**  
**MAINTENANCE DISPLAY TABLES (cont)**

TABLE	DISPLAY NAME	RANGE	UNITS	POINT NAME	WRITE STATUS
ENTHALPY	Outdoor Air Enthalpy Outside Air Temperature Outside Air Rel.Humidity Outside Air RH Sensor OA Dewpoint Temp Limit OutsideAir DewPoint Temp OutsideAir Humidity Ratio OA H2O Vapor Sat.Pressur OA H2O Partial.Press.Vap		dF %  dF dF "Hg "Hg	OAE OAT OARH OARHSENS OADEWCFG OADEWTMP OA_HUMR OA_PWS OA_PWS	forcible forcible config config
	Return Air Enthalpy Return Air Temperature Controlling Return Temp Return Air Rel.Humidity Return Air Temp Sensor Return Air RH Sensor		dF dF %	RAE RAT RETURN_T RARH RATSENS RARHSENS	forcible forcible forcible config config
	Altitude.....in feet: Atmospheric Pressure		"Hg	ALTITUDE ATMOPRES	config config
LINKDATA	Supervisory Element # Supervisory Bus Supervisory Block Number Average Occup. Heat Stp. Average Occup. Cool Stp. Average Unocc. Heat Stp. Average Unocc. Cool Stp. Average Zone Temperature Average Occup. Zone Temp Linkage System Occupied? Next Occupied Day Next Occupied Time Next Unoccupied Day Next Unoccupied Time Last Unoccupied Day Last Unoccupied Time		dF dF dF dF dF dF	SUPE-ADR SUPE-BUS BLOCKNUM AOHS AOCS AUHS AUCS AZT AOZT LOCC LNEXTOCC LNEXTOCC LNEXTUOD LNEXTUOD LNEXTUNC LLASTUOD LLASTUNC	
MILLIAMP	IAQ milliamps OAQ milliamps SP Reset milliamps 4-20 ma Demand Signal EDT Reset milliamps OARH milliamps RARH milliamps BP milliamps SP milliamps		ma ma ma ma ma ma ma ma ma	IAQ_MA OAQ_MA SPRST_MA DMDLMTMA EDTRESMA OARH_MA RARH_MA BP_MA SP_MA	forcible
MODES	System Mode.....: HVAC Mode.....: Control Mode.....:	ascii text strings ascii text strings ascii text strings			
	Currently Occupied Timed Override in effect DCV resetting min pos Supply Air Reset Demand Limit in Effect Temp.Compensated Start IAQ pre-occ purge active Linkage Active - DAV Mech.Cooling Locked Out HVAC Mode Numerical Form	On/Off On/Off On/Off On/Off On/Off On/Off On/Off On/Off On/Off 0-24		MODEOCCP MODETOVR MODEADCV MODESARS MODEDMLT MODETCST MODEIQPG MODELINK MODELLOCK MODEHVAC	
OCCDEFME	Current Day, Time & Date: Occupancy Controlled By:	ascii date & time ascii text ascii text ascii text		TIMEDATE OCDFTXT1 OCDFTXT2 OCDFTXT3 MODE_OCC	
	Currently Occupied  Current Occupied Time Current Unoccupied Time Next Occupied Day & Time Next Unocc. Day & Time Last Unocc. Day & Time Current Occup. Period # Timed-Override in Effect Timed-Override Duration	       Yes/No	       hours	  STRTTIME ENDTIME NXTOC_DT NXTUN_DT PRVUN_DT PER_NO OVERLAST OVR_HRS	

**APPENDIX B — CCN TABLES (cont)**  
**MAINTENANCE DISPLAY TABLES (cont)**

TABLE	DISPLAY NAME	RANGE	UNITS	POINT NAME	WRITE STATUS
PRESBLDG	Building Pressure Econo Damper Current Pos Power Exhaust Stage A Power Exhaust Stage B Power Exhaust Stage C		"H2O %	BP ECONOPOS PE_A PE_B PE_C	
	BP Load Factor BP Rise Per Stage			BPSMZ BPRISE	
	BP PID/Integral Term BP PID Threshold BP Deadband Building Pressure Error Rate of Chng of BPERORR High BP Override Low BP Override			BPINT BPZ BPY BPERORR BPRATE BPPOVRD BPLPOVRD	config config config config config config config
PRESDUCT	Static Pressure Supply Fan VFD Speed		"H2O %	SP SFAN_VFD	
	Static Pressure Setpoint Static Pressure Reset		"H2O	SPSP SPRESET	config forcible
STAGEGAS	Heating Mode.....: Requested Heat Stage Heating Control Point			HT_STAGE HEATCPNT	
	Staged Gas LAT Sum Staged Gas LAT 1 Staged Gas LAT 2 Staged Gas LAT 3 Staged Gas Limit Sw.Temp Heat PID Timer Staged Gas Capacity Calc Current Running Capacity Proportional Cap. Change Derivative Cap. Change Maximum Heat Stages Hi Limit Switch Tmp Mode LAT Cutoff Mode Capacity Clamp Mode		dF dF dF dF dF sec % %	LAT_SGAS LAT1SGAS LAT2SGAS LAT3SGAS LIMSWTMP HTSGTIMR HTSGCALC HTSG_CAP HTSG_P HTSG_D HTMAXSTG LIMTMODE LATCMODE CAPMODE	
STRTHOUR	Compressor A1 Run Hours Compressor A2 Run Hours Compressor B1 Run Hours Compressor B2 Run Hours		hours hours hours hours	HR_A1 HR_A2 HR_B1 HR_B2	config config config config
	Compressor A1 Starts Compressor A2 Starts Compressor B1 Starts Compressor B2 Starts			CY_A1 CY_A2 CY_B1 CY_B2	config config config config
SUMZ	Cooling Control Point Mixed Air Temperature Evaporator Discharge Tmp Return Air Temperature Outside Air Temperature Econo Damper Current Pos		dF dF dF dF dF %	COOLCPNT MAT EDT RAT OAT ECONOPOS	
	Capacity Threshold Adjst Capacity Load Factor Next Stage EDT Decrease Next Stage EDT Increase Rise Per Percent Capacity Cap Deadband Subtracting Cap Deadband Adding Cap Threshold Subtracting Cap Threshold Adding High Temp Cap Override Low Temp Cap Override Pull Down Cap Override Slow Change Cap Override	On/Off On/Off On/Off On/Off		Z_GAIN SMZ ADDRISE SUBRISE RISE_PCT Y_MINUS Y_PLUS Z_MINUS Z_PLUS HI_TEMP LOW_TEMP PULLDOWN SLO_CHNG	
SYSTEM	Reset All Current Alarms	Yes/No		ALRESET	config
	Reset the Device	Yes/No		RESETDEV	config
	Local Machine Disable	Yes/No		UNITSTOP	config
	Soft Stop Request	Yes/No		SOFTSTOP	forcible
	Emergency Stop	Enable/Disable		EMSTOP	forcible
	CEM AN1 10K temp J5,1-2	-40 - 240	dF	CEM10K1	forcible
	CEM AN2 10K temp J5,3-4	-40 - 240	dF	CEM10K2	forcible
	CEM AN3 10K temp J5,5-6	-40 - 240	dF	CEM10K3	forcible
	CEM AN4 10K temp J5,7-8	-40 - 240	dF	CEM10K4	forcible
	CEM AN1 4-20 ma J5,1-2	0-20	ma	CEM4201	forcible
	CEM AN2 4-20 ma J5,3-4	0-20	ma	CEM4202	forcible
	CEM AN3 4-20 ma J5,5-6	0-20	ma	CEM4203	forcible
	CEM AN4 4-20 ma J5,7-8	0-20	ma	CEM4204	forcible

**APPENDIX B — CCN TABLES (cont)**  
**MAINTENANCE DISPLAY TABLES (cont)**

TABLE	DISPLAY NAME	RANGE	UNITS	POINT NAME	WRITE STATUS
TESTCOOL	Compressor A1 Relay	ON/OFF		CMPA1TST	test
	Compressor A2 Relay	ON/OFF		CMPA2TST	test
	Min. Load Valve (HGBP)	ON/OFF		MLV_TST	test
	Compressor B1 Relay	ON/OFF		CMPB1TST	test
	Compressor B2 Relay	ON/OFF		CMPB2TST	test
TESTFANS	Supply Fan Relay	ON/OFF	%	SFAN_TST	test
	Supply Fan VFD Speed	0-100		SGVFDTST	test
	Condenser Fan Circuit A	ON/OFF		CNDA_TST	test
	Condenser Fan Circuit B	ON/OFF		CNDB_TST	test
TESTHEAT	Requested Heat Stage	0-MAX		HTST_TST	test
	Heat Relay 1	ON/OFF		HS1_TST	test
	Heat Relay 2	ON/OFF		HS2_TST	test
	Relay 3 W1 Gas Valve 2	ON/OFF		HS3_TST	test
	Relay 4 W2 Gas Valve 2	ON/OFF		HS4_TST	test
	Relay 5 W1 Gas Valve 3	ON/OFF		HS5_TST	test
	Relay 6 W2 Gas Valve 3	ON/OFF		HS6_TST	test
TESTINDP	Economizer Position Test			ECONCTST	test
	Economizer Power Test			ECONPTST	test
	Calibrate the Economizer?			ECON_CAL	test
	Power Exhaust Relay A			PE_A_TST	test
	Power Exhaust Relay B			PE_B_TST	test
	Power Exhaust Relay C			PE_C_TST	test
	Heat Interlock Relay	ON/OFF		HIR_TST	test
	Remote Alarm/Aux Relay	ON/OFF		ALRM_TST	test
VERSIONS	MBB CESR131343-	ascii version#		MBB_SW	
	ECB1 CESR131249-	ascii version#		ECB1_SW	
	ECB2 CESR131249-	ascii version#		ECB2_SW	
	SCB CESR131226-	ascii version#		SCB_SW	
	CEM CESR131174-	ascii version#		CEM_SW	
	MARQUEE CESR131171-	ascii version#		MARQ_SW	
	NAVIGATOR CESR130227-	ascii version#		NAVI_SW	

**TIME SCHEDULE CONFIG TABLE**

Allowable Entries: Day not selected = 0 Day selected = 1

	DAY FLAGS MTWTFSSH	OCCUPIED TIME	UNOCCUPIED TIME
Period 1:	00000000	00:00	00:00
Period 2:	00000000	00:00	00:00
Period 3:	00000000	00:00	00:00
Period 4:	00000000	00:00	00:00
Period 5:	00000000	00:00	00:00
Period 6:	00000000	00:00	00:00
Period 7:	00000000	00:00	00:00
Period 8:	00000000	00:00	00:00

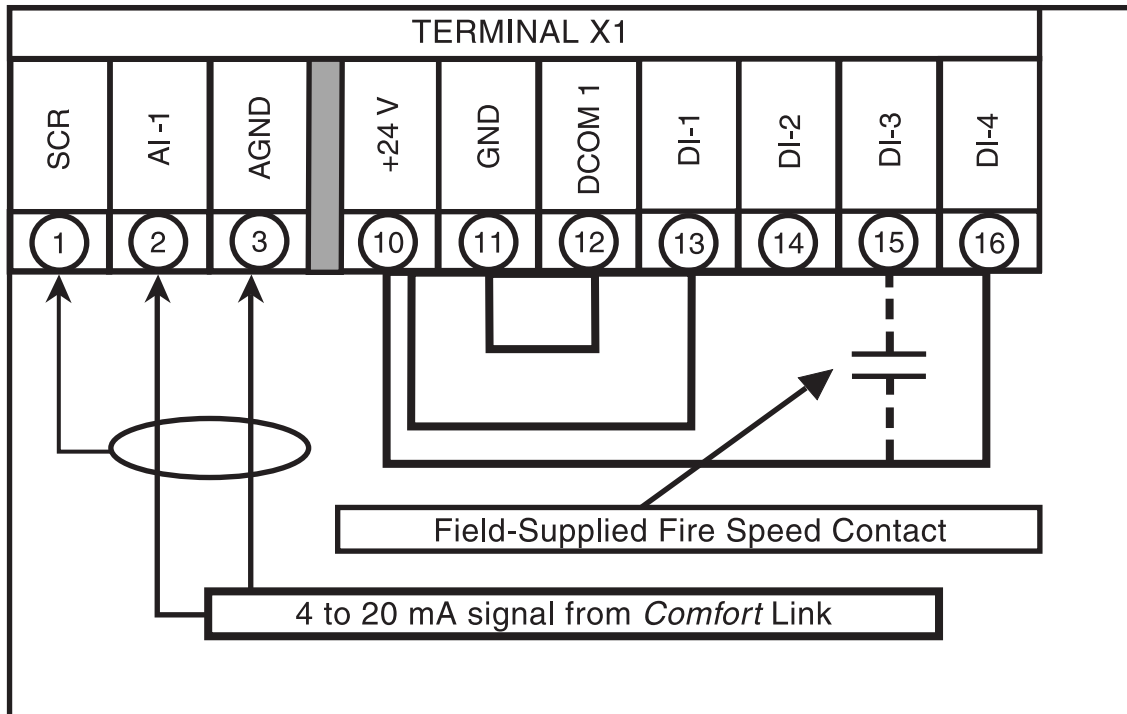
## APPENDIX C — VFD INFORMATION

On variable air volume units with optional VFD, the supply fan speed is controlled by a 3-phase VFD. The VFD is located in the supply fan section behind a removable panel. The VFD speed is controlled directly by the *ComfortLink* controls through a 4 to 20 mA signal based on a supply duct pressure sensor. The VFD has a display, which can be used for service diagnostics, but setup of the building pressure and control loop factors should be done through the scrolling marquee display. The VFD is powered during normal operation to prevent condensation from forming on the boards during the off mode and is stopped by driving the speed to 0 (by sending a 4 mA signal to the VFD).

The A Series units use ABB VFDs. The interface wiring for the VFDs is shown in Fig. A. The VFD connects through an isolation board to the 4 to 20 mA RCB board. Terminal designations are shown in Table A. Configurations are shown in Table B.

**Table A — VFD Terminal Designations**

TERMINAL	FUNCTION
U1 V1 W1	Three-Phase Main Circuit Input Power Supply
U2 V2 W2	Three-Phase AC Output to Motor, 0 V to Maximum Input Voltage Level
X1-11 (GND) X1-12 (COMMON)	Factory-supplied jumper
X1-10 (24 VDC) X1-13 (DI-1)	Run (factory-supplied jumper)
X1-10 (24 VDC) X1-16 (DI-4)	Start Enable 1 (Factory-supplied jumper). When opened the drive goes to emergency stop.
X1-2 (AI-1) X1-3 (AGND)	Factory wired for 4 to 20 mA remote input



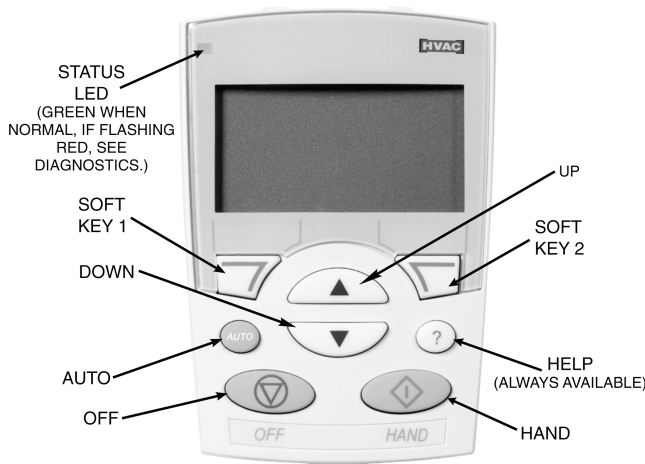
**Fig. A — VFD Wiring**

## APPENDIX C — VFD INFORMATION (cont)

### Table B — VFD Configurations

PARAMETER GROUP	PARAMETER TITLE	PARAMETER INDEX	CARRIER DEFAULT
Start-Up Data	LANGUAGE	9901	ENGLISH
	APPLIC MACRO	9902	USER 1
	MOTOR CTRL MODE	9904	SCALAR: FREQ
	MOTOR NOM VOLT	9905	460v
	MOTOR NOM CURR	9906	*TBD*
	MOTOR NOM FREQ	9907	60 Hz
	MOTOR NOM SPEED	9908	1750 rpm
Start/Stop/Dir	EXT1 COMMANDS	1001	DI-1
	DIRECTION	1003	REVERSE
Analog Inputs	MINIMUM AI1	1301	20.0 %
	MAXIMUM AI1	1302	100.0 %
Relay Outputs	RELAY OUTPUT 1	1401	STARTED
	RELAY OUTPUT 2	1402	RUN
	RELAY OUTPUT 3	1403	FAULT (-1)
System Controls	RUN ENABLE	1601	NOT SELECTED
	START ENABLE 1	1608	DI-4
OVER RIDE	OVERRIDE SEL	1701	DI-3
	OVERRIDE FREQ	1702	60 Hz
	OVERRIDE SPEED	1703	1750 rpm
	OVER PASS CODE	1704	ENTERED
	OVERRIDE	1705	ON
	STOP FUNCTION	2102	RAMP
Accel/Decel	ACCELER TIME 1	2202	30.0s
	DECELER TIME 1	2203	30.0s
MOTOR	SWITCHING FREQ	2606	8 kHz

**VFD Operation** — The VFD keypad is shown in Fig. B. The function of SOFT KEYS 1 and 2 change depending on what is displayed on the screen. The function of SOFT KEY 1 matches the word in the lower left-hand box on the display screen. The function of SOFT KEY 2 matches the word in the lower right-hand box on the display screen. If the box is empty, then the SOFT KEY does not have a function on that specific screen. The UP and DOWN keys are used to navigate through the menus. The OFF key is used to turn off the VFD. The AUTO key is used to change control of the drive to automatic control. The HAND key is used to change control of the drive to local (hand held) control. The HELP button is used to access the help screens.



**Fig. B — VFD Keypad**

**START UP WITH ASSISTANT** — Initial start-up has been performed at the factory. To start up the VFD with the Start-Up Assistant or reset the VFD with the Carrier defaults, perform the following procedure:

1. Select MENU (SOFT KEY 2). The Main menu will be displayed.
2. Use the UP or DOWN keys to highlight ASSISTANTS on the display screen and press ENTER (SOFT KEY 2).
3. Use the UP or DOWN keys to highlight Carrier Assistant and press SEL (SOFT KEY 2).
4. The Carrier Assistant will ask questions to determine the correct parameters for the VFD. Select the desired values and press SAVE (SOFT KEY 2) after every change. The process will continue until all the parameters are set.
  - a. The Carrier Assistant will ask “Is this an Air Handler or Rooftop?” Select “Rooftop.”
  - b. The Carrier Assistant will ask “Is this a High E or Premium E motor?” Select the correct efficiency type.
  - c. If the VFD can be used with two different size (HP) motors, then the Carrier Assistant will ask the user to choose the proper HP. Select the correct motor horsepower.

**START UP BY CHANGING PARAMETERS INDIVIDUALLY** — Initial start-up is performed at the factory. To start up the VFD with by changing individual parameters, perform the following procedure:

1. Select MENU (SOFT KEY 2). The Main menu will be displayed.
2. Use the UP or DOWN keys to highlight PARAMETERS on the display screen and press ENTER (SOFT KEY 2).
3. Use the UP or DOWN keys to highlight the desired parameter group and press SEL (SOFT KEY 2).

## APPENDIX C — VFD INFORMATION (cont)

4. Use the UP or DOWN keys to highlight the desired parameter and press EDIT (SOFT KEY 2).
5. Use the UP or DOWN keys to change the value of the parameter.
6. Press SAVE (SOFT KEY 2) to store the modified value. Press CANCEL (SOFT KEY 1) to keep the previous value. Any modifications that are not saved will not be changed.
7. Choose another parameter or press EXIT (SOFT KEY 1) to return to the listing of parameter groups. Continue until all the parameters have been configured and then press EXIT (SOFT KEY 1) to return to the main menu.

NOTE: The current parameter value appears above the highlight parameter. To view the default parameter value, press the UP and DOWN keys simultaneously. To restore the default factory settings, select the application macro “HVAC Default.”

**VFD Modes** — The VFD has several different modes for configuring, operating, and diagnosing the VFD. The modes are:

- Standard Display mode — shows drive status information and operates the drive
- Parameters mode — edits parameter values individually
- Start-up Assistant mode — guides the start-up and configuration
- Changed Parameters mode — shows all changed parameters
- Drive Parameter Backup mode — stores or uploads the parameters
- Clock Set mode — sets the time and date for the drive
- I/O Settings mode — checks and edits the I/O settings

**STANDARD DISPLAY MODE** — Use the standard display mode to read information on the drive status and operate the drive. To reach the standard display mode, press EXIT until the LCD display shows status information as described below. See Fig. C.

The top line of the LCD display shows the basic status information of the drive. The HAND icon indicates that the drive control is local from the control panel. The AUTO icon indicates that the drive is in remote control mode, such as the basic I/O (X1) or field bus.

The arrow icon indicates the drive and motor rotation status. A rotating arrow (clockwise or counterclockwise) indicates that the drive is running and at set point and the shaft direction is forward or reverse. A rotating blinking arrow indicates that the drive is running but not at set point. A stationary arrow indicates that the drive is stopped. For Carrier rooftop units, the correct rotation is counterclockwise.

The upper right corner shows the frequency set point that the drive will maintain.

Using parameter group 34, the middle of the LCD display can be configured to display 3 parameter values. The default display shows parameters 0103 (OUTPUT FREQ) in percentages, 0104 (CURRENT) in amperes, and 0120 (AII) in milliamperes.

The bottom corners of the LCD display show the functions currently assigned to the two soft keys. The lower middle displays the current time (if configured to show the time).

The first time the drive is powered up, it is in the OFF mode. To switch to local hand-held control and control the drive using the control panel, press and hold the HAND button. Pressing the HAND button switches the drive to hand control while keeping the drive running. Press the AUTO button to switch to

remote input control. To start the drive press the HAND or AUTO buttons, to stop the drive press the OFF button.

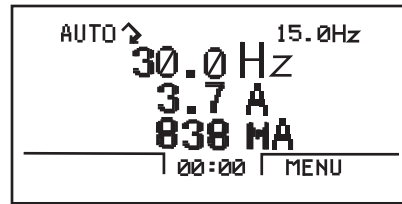


Fig. C — Standard Display Example

To adjust the speed in HAND mode, press the UP or DOWN buttons (the reference changes immediately). The reference can be modified in the local control (HAND) mode, and can be parameterized (using Group 11 reference select) to also allow modification in the remote control mode.

**PARAMETERS MODE** — The Parameters mode is used to change the parameters on the drive. To change parameters, perform the following procedure:

1. Select MENU (SOFT KEY 2). The Main menu will be displayed.
2. Use the UP or DOWN keys to highlight PARAMETERS on the display screen and press ENTER (SOFT KEY 2).
3. Use the UP or DOWN keys to highlight the desired parameter group and press SEL (SOFT KEY 2).
4. Use the UP or DOWN keys to highlight the desired parameter and press EDIT (SOFT KEY 2).
5. Use the UP or DOWN keys to change the value of the parameter.
6. Press SAVE (SOFT KEY 2) to store the modified value. Press CANCEL (SOFT KEY 1) to keep the previous value. Any modifications that are not saved will not be changed.
7. Choose another parameter or press EXIT (SOFT KEY 1) to return to the listing of parameter groups. Continue until all the parameters have been configured and then press EXIT (SOFT KEY 1) to return to the main menu.

NOTE: The current parameter value appears above the highlight parameter. To view the default parameter value, press the UP and DOWN keys simultaneously. To restore the default factory settings, select the Carrier application macro.

**START-UP ASSISTANT MODE** — To use the Start-Up Assistant, perform the following procedure:

1. Select MENU (SOFT KEY 2). The Main menu will be displayed.
2. Use the UP or DOWN keys to highlight ASSISTANTS on the display screen and press ENTER (SOFT KEY 2).
3. Use the UP or DOWN keys to highlight Commission Drive and press SEL (SOFT KEY 2).
4. The Start-Up Assistant will display the parameters that need to be configured. Select the desired values and press SAVE (SOFT KEY 2) after every change. The process will continue until all the parameters are set. The assistant checks to make sure that entered values are in range.

The assistant is divided into separate tasks. The user can activate the tasks one after the other or independently. The tasks are typically done in this order: Application, References 1 and 2, Start/Stop Control, Protections, Constant Speeds, PID Control, Low Noise Setup, Panel Display, Timed Functions, and Outputs.



## APPENDIX C — VFD INFORMATION (cont)

**CHANGED PARAMETERS MODE** — The Changed Parameters mode is used to view and edit recently changed parameters on the drive. To view the changed parameters, perform the following procedure:

1. Select MENU (SOFT KEY 2). The Main menu will be displayed.
2. Use the UP or DOWN keys to highlight CHANGED PAR on the display screen and press ENTER (SOFT KEY 2). A list of the recently changed parameters will be displayed.
3. Use the UP or DOWN keys to highlight the desired parameter group and press EDIT (SOFT KEY 2) to change the parameter if desired.
4. Press EXIT (SOFT KEY 1) to exit the Changed Parameters mode.

**DRIVE PARAMETER BACKUP MODE** — The drive parameter back up mode is used to export the parameters from one drive to another. The parameters can be uploaded from a VFD to the removable control panel. The control panel can then be transferred to another drive and the parameters downloaded into memory.

Depending on the motor and application, there are two options available. The first option is to download all parameters. This copies both application and motor parameters to the drive from the control panel. This is recommended when using the same application for drives of the same size. This can also be used to create a backup of the parameters group for the drive.

The second option downloads only the application parameters to the drive. This is recommended when using the same application for drives of different sizes. Parameters 9905, 9906, 9907, 9908, 9909, 1605, 1607, 5201, and group 51 parameters and internal motor parameters are not copied.

**Upload All Parameters** — To upload and store parameters in the control panel from the VFD, perform the following procedure:

1. Select MENU (SOFT KEY 2). The Main menu will be displayed.
2. Use the UP or DOWN keys to highlight PAR BACKUP on the display screen and press ENTER (SOFT KEY 2).
3. Use the UP or DOWN keys to highlight UPLOAD TO PANEL and press SEL (SOFT KEY 2).
4. The text “Copying Parameters” will be displayed with a progress indicator. To stop the process, select ABORT (SOFT KEY 1).
5. When the upload is complete, the text “Parameter upload successful” will be displayed.
6. The display will then return to the PAR BACKUP menu. Select EXIT (SOFT KEY 1) to return to the main menu.
7. The control panel can now be disconnected from the drive.

**Download All Parameters** — To download all parameters from the control panel to the VFD, perform the following procedure:

1. Install the control panel with the correct parameters onto the VFD.
2. Select MENU (SOFT KEY 2). The Main menu will be displayed.
3. Use the UP or DOWN keys to highlight PAR BACKUP on the display screen and press ENTER (SOFT KEY 2).
4. Use the UP or DOWN keys to highlight DOWNLOAD TO DRIVE ALL and press SEL (SOFT KEY 2).

5. The text “Restoring Parameters” will be displayed with a progress indicator. To stop the process, select ABORT (SOFT KEY 1).
6. When the download is complete, the text “Parameter download successful” will be displayed.
7. The display will then return to the PAR BACKUP menu. Select EXIT (SOFT KEY 1) to return to the main menu.
8. The control panel can now be disconnected from the drive.

**Download Application Parameters** — To download application parameters only to the control panel from the VFD, perform the following procedure:

1. Install the control panel with the correct parameters onto the VFD.
2. Select MENU (SOFT KEY 2). The Main menu will be displayed.
3. Use the UP or DOWN keys to highlight PAR BACKUP on the display screen and press ENTER (SOFT KEY 2).
4. Use the UP or DOWN keys to highlight DOWNLOAD APPLICATION and press SEL (SOFT KEY 2).
5. The text “Downloading Parameters (partial)” will be displayed with a progress indicator. To stop the process, select ABORT (SOFT KEY 1).
6. When the download is complete, the text “Parameter download successful” will be displayed.
7. The display will then return to the PAR BACKUP menu. Select EXIT (SOFT KEY 1) to return to the main menu.
8. The control panel can now be disconnected from the drive.

**CLOCK SET MODE** — The clock set mode is used for setting the date and time for the internal clock of the VFD. In order to use the timer functions of the VFD control, the internal clock must be set. The date is used to determine weekdays and is visible in the fault logs.

To set the clock, perform the following procedure:

1. Select MENU (SOFT KEY 2). The Main menu will be displayed.
2. Use the UP or DOWN keys to highlight CLOCK SET on the display screen and press ENTER (SOFT KEY 2). The clock set parameter list will be displayed.
3. Use the UP or DOWN keys to highlight CLOCK VISIBILITY and press SEL (SOFT KEY 2). This parameter is used to display or hide the clock on the screen. Use the UP or DOWN keys to change the parameter setting. Press OK (SOFT KEY 2) to save the configuration and return to the Clock Set menu.
4. Use the UP or DOWN keys to highlight SET TIME and press SEL (SOFT KEY 2). Use the UP or DOWN keys to change the hours and minutes. Press OK (SOFT KEY 2) to save the configuration and return to the Clock Set menu.
5. Use the UP or DOWN keys to highlight TIME FORMAT and press SEL (SOFT KEY 2). Use the UP or DOWN keys to change the parameter setting. Press OK (SOFT KEY 2) to save the configuration and return to the Clock Set menu.
6. Use the UP or DOWN keys to highlight SET DATE and press SEL (SOFT KEY 2). Use the UP or DOWN keys to change the day, month, and year. Press OK (SOFT KEY 2) to save the configuration and return to the Clock Set menu.

## APPENDIX C — VFD INFORMATION (cont)

7. Use the UP or DOWN keys to highlight DATE FORMAT and press SEL (SOFT KEY 2). Use the UP or DOWN keys to change the parameter setting. Press OK (SOFT KEY 2) to save the configuration and return to the Clock Set menu.
8. Press EXIT (SOFT KEY 1) twice to return to the main menu.

**I/O SETTINGS MODE** — The I/O Settings mode is used for viewing and editing the I/O settings.

To configure the I/O settings, perform the following procedure:

1. Select MENU (SOFT KEY 2). The Main menu will be displayed.
2. Use the UP or DOWN keys to highlight I/O SETTINGS on the display screen and press ENTER (SOFT KEY 2). The I/O Settings parameter list will be displayed.
3. Use the UP or DOWN keys to highlight the desired I/O setting and press SEL (SOFT KEY 2).
4. Use the UP or DOWN keys to select the parameter to view. Press OK (SOFT KEY 2).
5. Use the UP or DOWN keys to change the parameter setting. Press SAVE (SOFT KEY 2) to save the configuration. Press CANCEL (SOFT KEY 1) to keep the previous value. Any modifications that are not saved will not be changed.
6. Press EXIT (SOFT KEY 1) twice to return to the main menu.

**Third Party Controls** — For conversion to third party control of the VFD, perform the following procedure:

1. Remove the factory-installed jumper between X1-10 and X1-13 (control of VFD start/stop).
2. Remove the factory-installed jumper between X1-10 and X1-16 and replace with a normally closed safety contact for control of VFD start enable.
3. Install speed signal wires to AI-1 and AGND. This input is set at the factory for a 4 to 20 mA signal. If a 0 to 10 vdc signal is required, change DIP switch J1 (located above the VFD control terminal strip) to OFF (right position to left position) and change parameter 1301 to 0% from 20%.

**VFD Diagnostics** — The drive detects error situations and reports them using:

- the green and red LEDs on the body of the drive (located under the keypad)
- the status LED on the control panel
- the control panel display
- the Fault Word and Alarm Word parameter bits (parameters 0305 to 0309)

The form of the display depends on the severity of the error. The user can specify the severity for many errors by directing the drive to ignore the error situation, report the situation as an alarm, or report the situation as a fault.

**FAULTS (RED LED LIT)** — The VFD signals that it has detected a severe error, or fault, by:

- enabling the red LED on the drive (LED is either steady or flashing)
- setting an appropriate bit in a Fault Word parameter (0305 to 0307)
- overriding the control panel display with the display of a fault code
- stopping the motor (if it was on)

The fault code on the control panel display is temporary. Pressing the MENU, ENTER, UP button or DOWN buttons removes the fault message. The message reappears after a few seconds if the control panel is not touched and the fault is still active.

**ALARMS (GREEN LED FLASHING)** — For less severe errors, called alarms, the diagnostic display is advisory. For these situations, the drive is simply reporting that it had detected something unusual. In these situations, the drive:

- flashes the green LED on the drive (does not apply to alarms that arise from control panel operation errors)
- sets an appropriate bit in an Alarm Word parameter (0308 or 0309)
- overrides the control panel display with the display of an alarm code and/or name

Alarm messages disappear from the control panel display after a few seconds. The message returns periodically as long as the alarm condition exists.

**CORRECTING FAULTS** — The recommended corrective action for faults is shown in the Fault Listing Table C. The VFD can also be reset to remove the fault. If an external source for a start command is selected and is active, the VFD may start immediately after fault reset.

To reset a fault indicated by a flashing red LED, turn off the power for 5 minutes. To reset a fault indicated by a red LED (not flashing), press RESET from the control panel or turn off the power for 5 minutes. Depending on the value of parameter 1604 (FAULT RESET SELECT), digital input or serial communication could also be used to reset the drive. When the fault has been corrected, the motor can be started.

**HISTORY** — For reference, the last three fault codes are stored into parameters 0401, 0412, 0413. For the most recent fault (identified by parameter 0401), the drive stores additional data (in parameters 0402 through 0411) to aid in troubleshooting a problem. For example, a parameter 0404 stores the motor speed at the time of the fault. To clear the fault history (all of Group 04, Fault History parameters), follow these steps:

1. In the control panel, Parameters mode, select parameter 0401.
2. Press EDIT.
3. Press the UP and DOWN buttons simultaneously.
4. Press SAVE.

**CORRECTING ALARMS** — To correct alarms, first determine if the Alarm requires any corrective action (action is not always required). Use Table D to find and address the root cause of the problem.

If diagnostics troubleshooting has determined that the drive is defective during the warranty period, contact ABB Automation Inc., at 1-800-435-7365, option 4, option 3. A qualified technician will review the problem with the caller and make a determination regarding how to proceed. This may involve dispatching a designated service station (DSS) representative from an authorized station, dispatching a replacement unit, or advising return for repair.

**VFD Maintenance** — If installed in an appropriate environment, the VFD requires very little maintenance.

Table E lists the routine maintenance intervals recommended by Carrier.

**HEAT SINK** — The heat sink fins accumulate dust from the cooling air. Since a dusty sink is less efficient at cooling the drive, overtemperature faults become more likely. In a normal environment check the heat sink annually, in a dusty environment check more often.

## APPENDIX C — VFD INFORMATION (cont)

### Table C — Fault Codes

FAULT CODE	FAULT NAME IN PANEL	DESCRIPTION AND RECOMMENDED CORRECTIVE ACTION
1	OVERCURRENT	Output current is excessive. Check for excessive motor load, insufficient acceleration time (parameters 2202 ACCELER TIME 1, default 30 seconds), or faulty motor, motor cables or connections.
2	DC OVERVOLT	Intermediate circuit DC voltage is excessive. Check for static or transient over voltages in the input power supply, insufficient deceleration time (parameters 2203 DECELER TIME 1, default 30 seconds), or undersized brake chopper (if present).
3	DEV OVERTEMP	Drive heat sink is overheated. Temperature is at or above 115 C (239 F). Check for fan failure, obstructions in the air flow, dirt or dust coating on the heat sink, excessive ambient temperature, or excessive motor load.
4	SHORT CIRC	Fault current. Check for short-circuit in the motor cable(s) or motor or supply disturbances.
5	OVERLOAD	Inverter overload condition. The drive output current exceeds the ratings.
6	DC UNDERVOLT	Intermediate circuit DC voltage is not sufficient. Check for missing phase in the input power supply, blown fuse, or under voltage on main circuit.
7	AI1 LOSS	Analog input 1 loss. Analog input value is less than AI1 FLT LIMIT (3021). Check source and connection for analog input and parameter settings for AI1 FLT LIMIT (3021) and 3001 AI<MIN FUNCTION.
8	AI2 LOSS	Analog input 2 loss. Analog input value is less than AI2 FLT LIMIT (3022). Check source and connection for analog input and parameter settings for AI2 FLT LIMIT (3022) and 3001 AI<MIN FUNCTION.
9	MOT OVERTEMP	Motor is too hot, as estimated by the drive. Check for overloaded motor. Adjust the parameters used for the estimate (3005 through 3009). Check the temperature sensors and Group 35 parameters.
10	PANEL LOSS	Panel communication is lost and either drive is in local control mode (the control panel displays LOC), or drive is in remote control mode (REM) and is parameterized to accept start/stop, direction or reference from the control panel. To correct check the communication lines and connections. Check parameter 3002 PANEL COMM ERROR, parameters in Group 10: Command Inputs and Group 11:Reference Select (if drive operation is REM).
11	ID RUN FAIL	The motor ID run was not completed successfully. Check motor connections.
12	MOTOR STALL	Motor or process stall. Motor is operating in the stall region. Check for excessive load or insufficient motor power. Check parameters 3010 through 3012.
13	RESERVED	Not used.
14	EXT FAULT 1	Digital input defined to report first external fault is active. See parameter 3003 EXTERNAL FAULT 1.
15	EXT FAULT 2	Digital input defined to report second external fault is active. See parameter 3004 EXTERNAL FAULT 2.
16	EARTH FAULT	The load on the input power system is out of balance. Check for faults in the motor or motor cable. Verify that motor cable does not exceed maximum specified length.
17	UNDERLOAD	Motor load is lower than expected. Check for disconnected load. Check parameters 3013 UNDERLOAD FUNCTION through 3015 UNDERLOAD CURVE.
18	THERM FAIL	Internal fault. The thermistor measuring the internal temperature of the drive is open or shorted. Contact Carrier.
19	OPEX LINK	Internal fault. A communication-related problem has been detected between the OMIO and OINT boards. Contact Carrier.
20	OPEX PWR	Internal fault. Low voltage condition detected on the OINT board. Contact Carrier.
21	CURR MEAS	Internal fault. Current measurement is out of range. Contact Carrier.
22	SUPPLY PHASE	Ripple voltage in the DC link is too high. Check for missing main phase or blown fuse.
23	RESERVED	Not used.
24	OVERSPEED	Motor speed is greater than 120% of the larger (in magnitude) of 2001 MINIMUM SPEED or 2002 MAXIMUM SPEED parameters. Check parameter settings for 2001 and 2002. Check adequacy of motor braking torque. Check applicability of torque control. Check brake chopper and resistor.
25	RESERVED	Not used.
26	DRIVE ID	Internal fault. Configuration block drive ID is not valid.
27	CONFIG FILE	Internal configuration file has an error. Contact Carrier.
28	SERIAL 1 ERR	Field bus communication has timed out. Check fault setup (3018 COMM FAULT FUNC and 3019 COMM FAULT TIME). Check communication settings (Group 51 or 53 as appropriate). Check for poor connections and/or noise on line.
29	EFB CON FILE	Error in reading the configuration file for the field bus adapter.
30	FORCE TRIP	Fault trip forced by the field bus. See the field bus reference literature.
31	EFB 1	Fault code reserved for the EFB protocol application. The meaning is protocol dependent.
32	EFB 2	Fault code reserved for the EFB protocol application. The meaning is protocol dependent.
33	EFB 3	Fault code reserved for the EFB protocol application. The meaning is protocol dependent.
34	MOTOR PHASE	Fault in the motor circuit. One of the motor phases is lost. Check for motor fault, motor cable fault, thermal relay fault, or internal fault.
35	OUTP WIRING	Error in power wiring suspected. Check that input power wired to drive output. Check for ground faults.
101-105	SYSTEM ERROR	Error internal to the drive. Contact Carrier and report the error number.
201-206	SYSTEM ERROR	Error internal to the drive. Contact Carrier and report the error number.
1000	PAR HZRPM	Parameter values are inconsistent. Check for any of the following: 2001 MINIMUM SPEED > 2002 MAXIMUM SPEED 2007 MINIMUM FREQ > 2008 MAXIMUM FREQ 2001 MINIMUM SPEED / 9908 MOTOR NOM SPEED is outside of the range: -128/+128 2002 MAXIMUM SPEED / 9908 MOTOR NOM SPEED is outside of the range: -128/+128 2007 MINIMUM FREQ / 9907 MOTOR NOM FREQ is outside of the range: -128/+128 2008 MAXIMUM FREQ / 9907 MOTOR NOM FREQ is outside of the range: -128/+128
1001	PAR PFA REFNG	Parameter values are inconsistent. Check that 2007 MINIMUM FREQ is negative, when 8123 PFA ENABLE is active.
1002	PAR PFA IOCNF	Parameter values are inconsistent. The number of programmed PFA relays does not match with Interlock configuration, when 8123 PFA ENABLE is active. Check consistency of RELAY OUTPUT parameters 1401 through 1403, and 1410 through 1412. Check 8117 NR OF AUX MOTORS, 8118 AUTOCHANGE INTERV, and 8120 INTERLOCKS.
1003	PAR AI SCALE	Parameter values are inconsistent. Check that parameter 1301 AI 1 MIN > 1302 AI 1 MAX and that parameter 1304 AI 2 MIN > 1305 AI 2 MAX.
1004	PAR AO SCALE	Parameter values are inconsistent. Check that parameter 1504 AO 1 MIN > 1505 AO 1 MAX and that parameter 1510 AO 2 MIN > 1511 AO 2 MAX.
1005	PAR PCU 2	Parameter values for power control are inconsistent: Improper motor nominal kVA or motor nominal power. Check the following parameters: $1.1 < (9906 \text{ MOTOR NOM CURR} * 9905 \text{ MOTOR NOM VOLT} * 1.73 / \text{PN}) < 2.6$ Where: PN = $1000 * 9909 \text{ MOTOR NOM POWER}$ (if units are kW) or PN = $746 * 9909 \text{ MOTOR NOM POWER}$ (if units are HP, e.g., in US)
1006	PAR EXT RO	Parameter values are inconsistent. Check the extension relay module for connection and 1410 through 1412 RELAY OUTPUTS 4 through 6 have non-zero values.
1007	PAR FBUS	Parameter values are inconsistent. Check that a parameter is set for field bus control (e.g., 1001 EXT1 COMMANDS = 10 (COMM)), but 9802 COMM PROT SEL = 0.
1008	PAR PFA MODE	Parameter values are inconsistent. The 9904 MOTOR CTRL MODE must = 3 (SCALAR SPEED) when 8123 PFA ENABLE activated.
1009	PAR PCU 1	Parameter values for power control are inconsistent or improper motor nominal frequency or speed. Check for both of the following: $1 < (60 * 9907 \text{ MOTOR NOM FREQ} / 9908 \text{ MOTOR NOM SPEED} < 16$ $0.8 < 9908 \text{ MOTOR NOM SPEED} / (120 * 9907 \text{ MOTOR NOM FREQ} / \text{Motor poles}) < 0.992$
1010	OVERRIDE/PFA CONFLICT	Override mode is enabled and PFA is activated at the same time. This cannot be done because PFA interlocks cannot be observed in the override mode.

## APPENDIX C — VFD INFORMATION (cont)

### Table D — Alarm Codes

ALARM CODE	ALARM NAME IN PANEL	DESCRIPTION AND RECOMMENDED CORRECTIVE ACTION
2001	—	Reserved
2002	—	Reserved
2003	—	Reserved
2004	DIR LOCK	The change in direction being attempted is not allowed. Do not attempt to change the direction of motor rotation, or Change parameter 1003 DIRECTION to allow direction change (if reverse operation is safe).
2005	I/O COMM	Field bus communication has timed out. Check fault setup (3018 COMM FAULT FUNC and 3019 COMM FAULT TIME). Check communication settings (Group 51 or 53 as appropriate). Check for poor connections and/or noise on line.
2006	AI1 LOSS	Analog input 1 is lost, or value is less than the minimum setting. Check input source and connections. Check the parameter that sets the minimum (3021) and the parameter that sets the Alarm/Fault operation (3001).
2007	AI2 LOSS	Analog input 2 is lost, or value is less than the minimum setting. Check input source and connections. Check parameter that sets the minimum (3022) and the parameter that sets the Alarm/Fault operation (3001).
2008	PANEL LOSS	Panel communication is lost and either the VFD is in local control mode (the control panel displays HAND), or the VFD is in remote control mode (AUTO) and is parameterized to accept start/stop, direction or reference from the control panel. To correct, check the communication lines and connections, Parameter 3002 PANEL LOSS, and parameters in groups 10 COMMAND INPUTS and 11 REFERENCE SELECT (if drive operation is REM).
2009	—	Reserved
2010	MOT OVERTEMP	Motor is hot, based on either the VFD estimate or on temperature feedback. This alarm warns that a Motor Overload fault trip may be near. Check for overloaded motor. Adjust the parameters used for the estimate (3005 through 3009). Check the temperature sensors and Group 35 parameters.
2011	UNDERLOAD	Motor load is lower than expected. This alarm warns that a Motor Underload fault trip may be near. Check that the motor and drive ratings match (motor is NOT undersized for the drive). Check the settings on parameters 3013 to 3015.
2012	MOTOR STALL	Motor is operating in the stall region. This alarm warns that a Motor Stall fault trip may be near.
2013*	AUTORESET	This alarm warns that the drive is about to perform an automatic fault reset, which may start the motor. To control automatic reset, use parameter group 31 (AUTOMATIC RESET).
2014*	AUTOCHANGE	This alarm warns that the PFA autochange function is active. To control PFA, use parameter group 81 (PFA) and the Pump Alternation macro.
2015	PFA INTERLOCK	This alarm warns that the PFA interlocks are active, which means that the drive cannot start any motor (when Autochange is used), or a speed regulated motor (when Autochange is not used).
2016	—	Reserved
2017*	OFF BUTTON	This alarm indicates that the OFF button has been pressed.
2018*	PID SLEEP	This alarm warns that the PID sleep function is active, which means that the motor could accelerate when the PID sleep function ends. To control PID sleep, use parameters 4022 through 4026 or 4122 through 4126.
2019	ID RUN	The VFD is performing an ID run.
2020	OVERRIDE	Override mode is activated.
2021	START ENABLE 1 MISSING	This alarm warns that the Start Enable 1 signal is missing. To control Start Enable 1 function, use parameter 1608. To correct, check the digital input configuration and the communication settings.
2022	START ENABLE 2 MISSING	This alarm warns that the Start Enable 2 signal is missing. To control Start Enable 2 function, use parameter 1609. To correct, check the digital input configuration and the communication settings.
2023	EMERGENCY STOP	Emergency stop is activated.

\*This alarm is not indicated by a relay output, even when the relay output is configured to indicate alarm conditions, parameter 1401 RELAY OUTPUT = 5 (ALARM) or 16 (FLT/ALARM).

Check the heat sink as follows (when necessary):

1. Remove power from drive.
2. Remove the cooling fan.
3. Blow clean compressed air (not humid) from bottom to top and simultaneously use a vacuum cleaner at the air outlet to trap the dust. If there a risk of the dust entering adjoining equipment, perform the cleaning in another room.
4. Replace the cooling fan.
5. Restore power.

### Table E — Maintenance Intervals

MAINTENANCE	INTERVAL
Heat Sink Temperature Check and Cleaning	Every 6 to 12 months (depending on the dustiness of the environment)
Main Cooling Fan Replacement	Every five years
Internal Enclosure Cooling Fan Replacement	Every three years
Capacitor Change (Frame Size R5 and R6)	Every ten years
HVAC Control Panel Battery Change	Every ten years

## APPENDIX C — VFD INFORMATION (cont)

**MAIN FAN REPLACEMENT** — The main cooling fan of the VFD has a life span of about 60,000 operating hours at maximum rated operating temperature and drive load. The expected life span doubles for each 18 F drop in the fan temperature (fan temperature is a function of ambient temperatures and drive loads).

Fan failure can be predicted by the increasing noise from fan bearings and the gradual rise in the heat sink temperature in spite of heat sink cleaning. If the drive is operated in a critical part of a process, fan replacement is recommended once these symptoms start appearing. Replacement fans are available from Carrier.

To replace the main fan for frame sizes R1 through R4, perform the following (see Fig. D):

1. Remove power from drive.
2. Remove drive cover.
3. For frame sizes R1 and R2, press together the retaining clips on the fan cover and lift. For frame sizes R3 and R4, press in on the lever located on the left side of the fan mount, and rotate the fan up and out.
4. Disconnect the fan cable.
5. Install the new fan by reversing Steps 2 to 4.
6. Restore power.

To replace the main fan for frame sizes R5 and R6, perform the following (see Fig. E):

1. Remove power from drive.
2. Remove the screws attaching the fan.
3. Disconnect the fan cable.
4. Install the fan in reverse order.
5. Restore power.

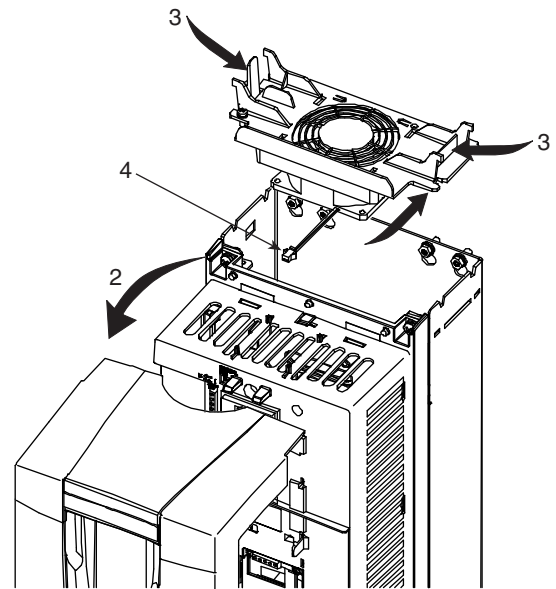
**INTERNAL ENCLOSURE FAN REPLACEMENT** — The VFD IP 54 / UL Type 12 enclosures have an additional internal fan to circulate air inside the enclosure.

To replace the internal enclosure fan for frame sizes R1 to R4, perform the following (see Fig. F):

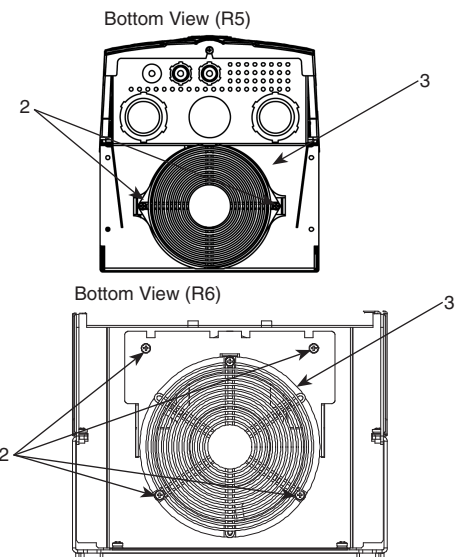
1. Remove power from drive.
2. Remove the front cover.
3. The housing that holds the fan in place has barbed retaining clips at each corner. Press all four clips toward the center to release the barbs.
4. When the clips/barbs are free, pull the housing up to remove from the drive.
5. Disconnect the fan cable.
6. Install the fan in reverse order, noting the following: the fan airflow is up (refer to arrow on fan); the fan wire harness is toward the front; the notched housing barb is located in the right-rear corner; and the fan cable connects just forward of the fan at the top of the drive.

To replace the internal enclosure fan for frame sizes R5 or R6, perform the following:

1. Remove power from drive.
2. Remove the front cover.
3. Lift the fan out and disconnect the cable.
4. Install the fan in reverse order.
5. Restore power.



**Fig. D — Main Fan Replacement (Frame Sizes R1-R4)**

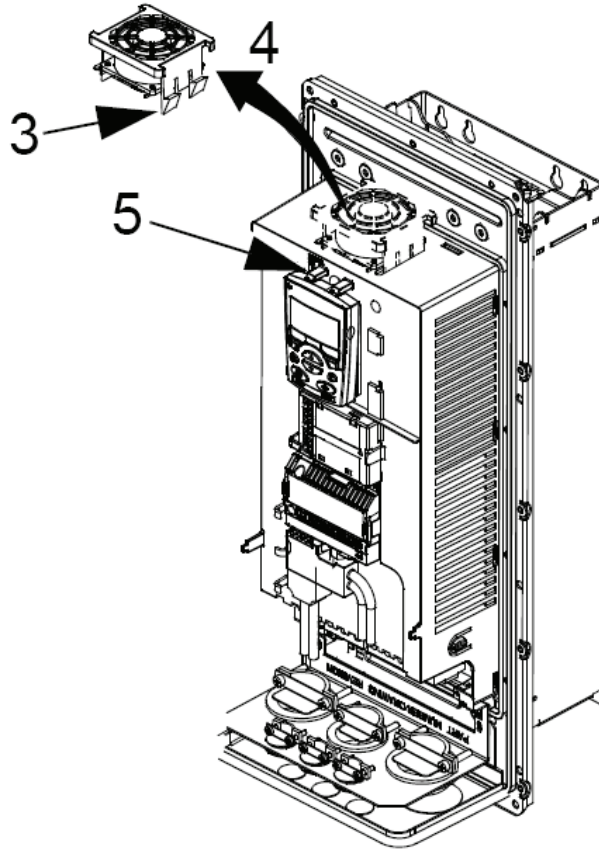


**Fig. E — Main Fan Replacement (Frame Sizes R5 and R6)**

**CONTROL PANEL CLEANING** — Use a soft damp cloth to clean the control panel. Avoid harsh cleaners which could scratch the display window.

**BATTERY REPLACEMENT** — A battery is only used in assistant control panels that have the clock function available and enabled. The battery keeps the clock operating in memory during power interruptions. The expected life for the battery is greater than ten years. To remove the battery, use a coin to rotate the battery holder on the back of the control panel. Replace the battery with type CR2032.

**APPENDIX C — VFD INFORMATION (cont)**



**Fig. F — Internal Enclosure Fan Replacement**

## APPENDIX D — MODE SELECTION PROCESS

The following section is to be used in conjunction with Fig. 4 on page 34. To help determine why the unit controls are in a certain mode, the programming logic is provided below. The software will proceed, step by step, until a mode is reached. If an “If” statement is true, then that mode will be entered. The “Else” statement refers to other possible choices.

If the System Mode is OFF:

```

{ If the fire shut down input (Inputs→FIRE→FSD)
  is in “alarm”:
    HVAC mode: ("Fire Shut Down ") OFF
  Else
    HVAC mode: ("Disabled ") OFF}
Else If: The rooftop is not in “factory test” and a fire
smoke-control mode is “alarming”:
{ If the pressurization input (Inputs→FIRE→PRES)
  is in “alarm”:
    HVAC mode: ("Pressurization ")
  Else If the evacuation input (Inputs→FIRE→EVAC)
  is in “alarm”:
    HVAC mode: ("Evacuation ")
  Else If the smoke purge input (Inputs→FIRE→PURG)
  is in “alarm”:
    HVAC mode: ("Smoke Purge ")
  Else If: Someone changed the machine’s
  control type (Configuration→UNIT→C.TYP) during
  run time, a 15 second delay is called out:
{   HVAC mode: ("Disabled ") OFF}
  Else If: The System Mode is TEST:
{   HVAC mode: ("Test ")
  Else If: The “soft stop” command (Service Test→S.STP)
  is forced to YES:
{   HVAC mode: ("SoftStop Request")}
  Else If: The remote switch config (Configuration→
UNIT→RM.CF)=2; “start/stop”, and the remote
  input state (Inputs→GEN.I→REMT)=ON:
{   HVAC mode: ("Rem. Sw. Disable") OFF}
  Else If: Configured for static pressure control
  (Configuration→SP→SP.CF = 1,2) and the static
  pressure sensor (Pressures→AIR.P→SP) fails:
{   HVAC mode: ("Static Pres.Fail") OFF}
  Else If: Configured for supply fan status monitoring
  (Configuration→UNIT→SFS.M = 1,2) and
  configured to shut the unit down on fan status fail
  (Configuration→UNIT→SFS.S = YES)
{   HVAC mode: ("Fan Status Fail ") OFF}
  Else If: The unit is just waking up from a power reset
{   HVAC mode: ("Starting Up ") OFF}
  Else If: A compressor is diagnosed as being “Stuck On”
{   HVAC mode: ("Comp. Stuck On ")
  Else The control is free to select the normal heating/
  cooling HVAC modes:

```

```

HVAC mode: ("Off ")
— The unit is off and no operating modes are active.
HVAC mode: ("Tempering Vent ")
— The economizer is at minimum vent position but
the supply air temperature has dropped below the
tempering vent set point. Gas heat is used to
temper the ventilation air.
HVAC mode: ("Tempering LoCool")
— The economizer is at minimum vent position but
the combination of the outside-air temperature and
the economizer position has dropped the supply-air
temperature below the tempering cool set point.
Gas heat is used to temper the ventilation air.
HVAC mode: ("Tempering HiCool")
— The economizer is at minimum vent position but
the combination of the outside air temperature and
the economizer position has dropped the supply air
temperature below the tempering cool set point.
Gas heat is used to temper the ventilation air.
HVAC mode: ("Re-Heat")
— The unit is operating in reheat mode.
HVAC mode: ("Dehumidification")
— The unit is operating in dehumidification mode.
HVAC mode: ("Vent ")
— This is a normal operation mode where no heating
or cooling is required and outside air is being
delivered to the space to control IAQ levels.
HVAC mode: ("Low Cool ")
— This is a normal cooling mode when a low cooling
demand exists.
HVAC mode: ("High Cool ")
— This is a normal cooling mode when a high
cooling demand exists.
HVAC mode: ("Low Heat ")
— This is a normal heating mode when a low
heating demand exists.
HVAC mode: ("High Heat ")
— This is a normal heating mode when a high
heating demand exists.
HVAC mode: ("Unocc. Free Cool")
— In this mode the unit will operate in cooling but
will be using the economizer for free cooling.
Entering this mode will depend on the status of the
outside air. The unit can be configured for outside
air changeover, differential dry bulb changeover,
outside air enthalpy changeover, differential
enthalpy changeover, or a custom arrangement
of enthalpy/dewpoint and dry bulb. See the
Economizer section for further details.

```

NOTE: There is also a transitional mode whereby the machine may be waiting for relay timeguards to expire before shutting the machine completely down:

```

HVAC mode: ("Shutting Down ")

```

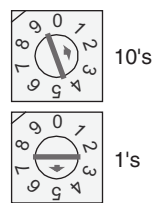
## APPENDIX E — UPC OPEN CONTROLLER

The following section is used to configure the UPC Open. The UPC Open controller is mounted in a separate enclosure below the main control box.

**To Address the UPC Open Controller** — The user must give the UPC Open controller an address that is unique on the BACnet\* network. Perform the following procedure to assign an address:

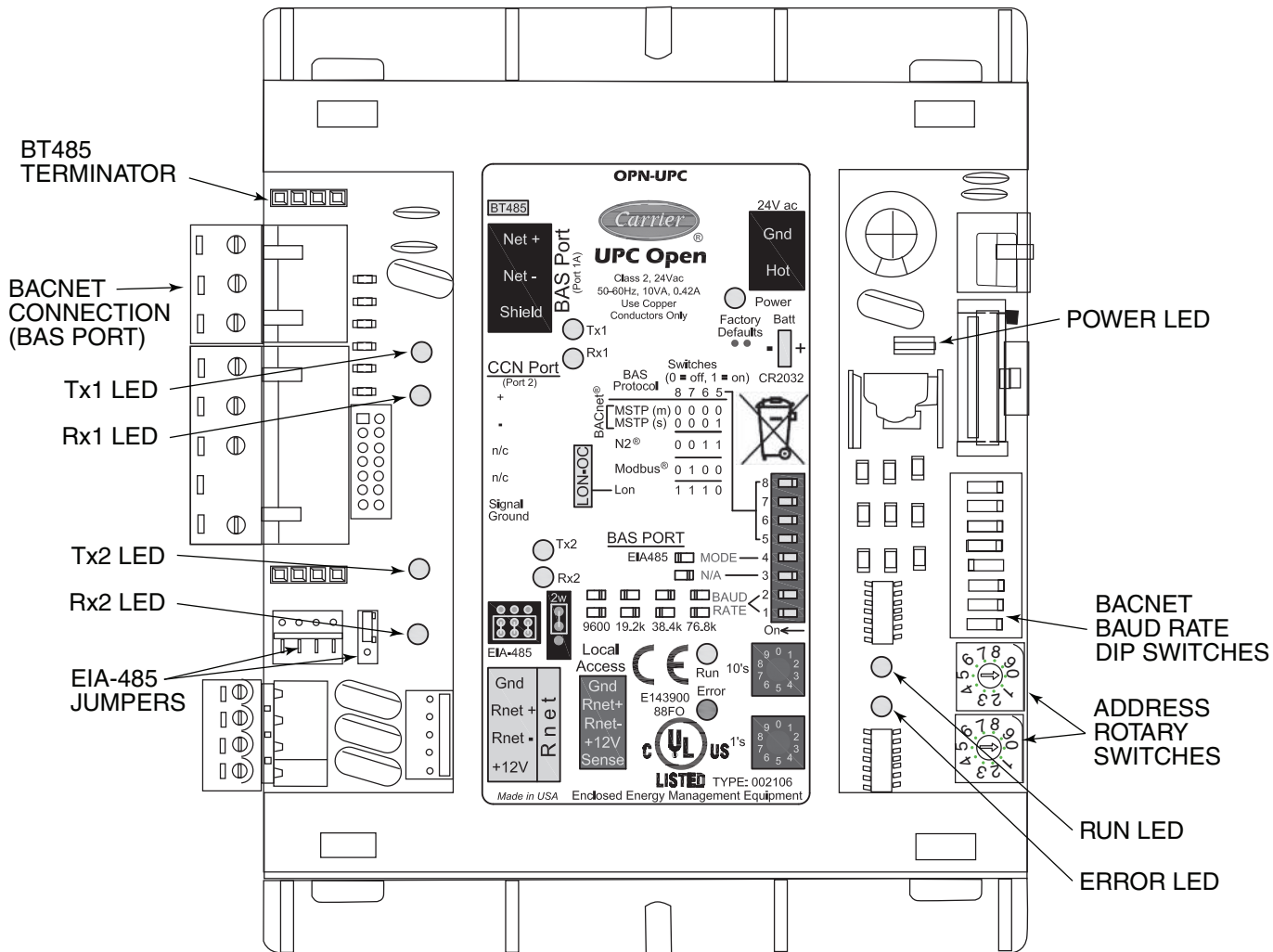
1. If the UPC Open controller is powered, pull the screw terminal connector from the controller's power terminals labeled Gnd and HOT. The controller reads the address each time power is applied to it.
2. Using the rotary switches (see Fig. G and H), set the controller's address. Set the Tens (10's) switch to the tens digit of the address, and set the Ones (1's) switch to the ones digit.

As an example in Fig. G, if the controller's address is 25, point the arrow on the Tens (10's) switch to 2 and the arrow on the Ones (1's) switch to 5.



**Fig. G — Address Rotary Switches**

**BACNET DEVICE INSTANCE ADDRESS** — The UPC Open controller also has a BACnet Device Instance address. This Device Instance **MUST** be unique for the complete BACnet system in which the UPC Open controller is installed. The Device Instance is auto generated by default and is derived by adding the MAC address to the end of the Network Number. The Network Number of a new UPC Open controller is 16101, but it can be changed using i-Vu® Tools or BACView device. By default, a MAC address of 20 will result in a Device Instance of 16101 + 20 which would be a Device Instance of 1610120.



**Fig. H — UPC Open Controller**

\* Sponsored by ASHRAE (American Society of Heating, Refrigerating, and Air Conditioning Engineers).



## APPENDIX E — UPC OPEN CONTROLLER (cont)

**Configuring the BAS Port for BACnet MS/TP** — Use the same baud rate and communication settings for all controllers on the network segment. The UPC Open controller is fixed at 8 data bits, No Parity, and 1 Stop bit for this protocol's communications.

If the UPC Open controller has been wired for power, pull the screw terminal connector from the controller's power terminals labeled Gnd and HOT. The controller reads the DIP Switches and jumpers each time power is applied to it.

Set the BAS Port DIP switch DS3 to “enable.” Set the BAS Port DIP switch DS4 to “E1485.” Set the BMS Protocol DIP switches DS8 through DS5 to “MSTP.” See Table F.

**Table F — SW3 Protocol Switch Settings for MS/TP**

DS8	DS7	DS6	DS5	DS4	DS3
Off	Off	Off	Off	On	Off

Verify that the EIA-485 jumpers below the CCN Port are set to EIA-485 and 2W.

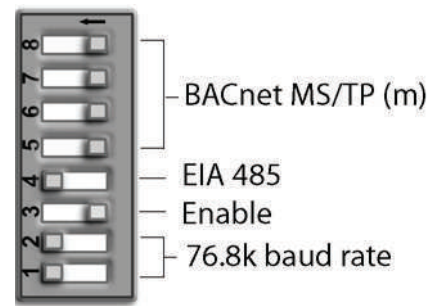
The example in Fig. J shows the BAS Port DIP Switches set for 76.8k (Carrier default) and MS/TP.

Set the BAS Port DIP Switches DS2 and DS1 for the appropriate communications speed of the MS/TP network (9600, 19.2k, 38.4k, or 76.8k bps). See Fig. I and Table G.

**Table G — Baud Selection Table**

BAUD RATE	DS2	DS1
9,600	Off	Off
19,200	On	Off
38,400	Off	On
76,800	On	On

**Wiring the UPC Open Controller to the MS/TP Network** — The UPC Open controller communicates using BACnet on an MS/TP network segment communications at 9600 bps, 19.2 kbps, 38.4 kbps, or 76.8 kbps.



**Fig. I — DIP Switches**

Wire the controllers on an MS/TP network segment in a daisy-chain configuration. Wire specifications for the cable are 22 AWG (American Wire Gage) or 24 AWG, low-capacitance, twisted, stranded, shielded copper wire. The maximum length is 2000 ft.

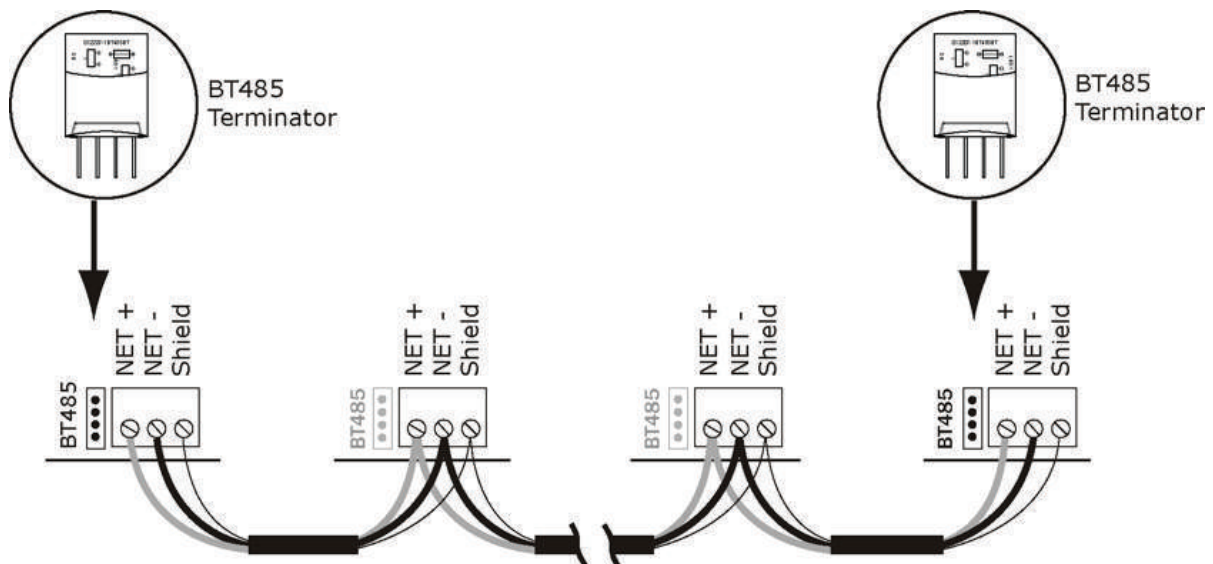
Install a BT485 terminator on the first and last controller on a network segment to add bias and prevent signal distortions due to echoing. See Fig. H, J, and K.

To wire the UPC Open controller to the BAS network:

1. Pull the screw terminal connector from the controller's BAS Port.
2. Check the communications wiring for shorts and grounds.
3. Connect the communications wiring to the BAS port's screw terminals labeled Net +, Net -, and Shield.

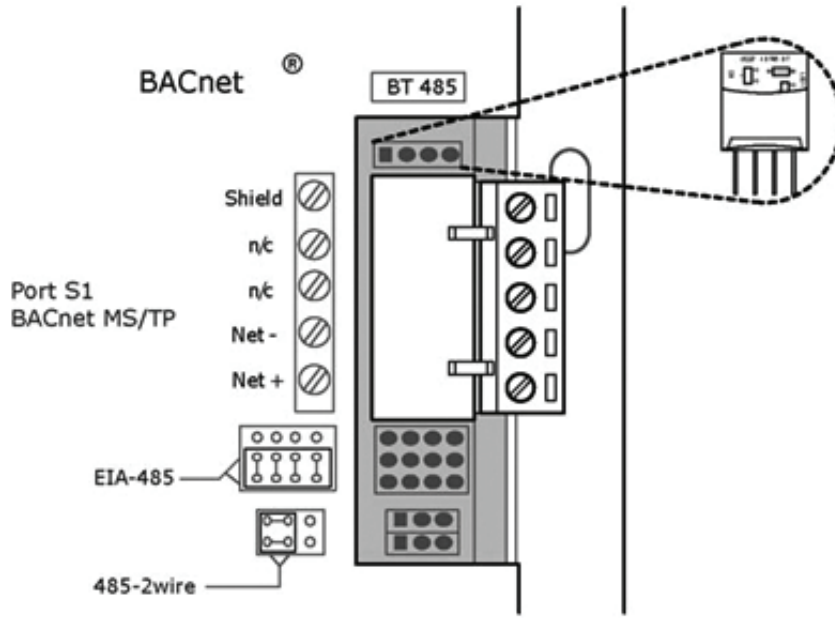
NOTE: Use the same polarity throughout the network segment.

4. Insert the power screw terminal connector into the UPC Open controller's power terminals if they are not currently connected.
5. Verify communication with the network by viewing a module status report. To perform a module status report using the BACview keypad/display unit, press and hold the “FN” key then press the “.” Key.



**Fig. J — Network Wiring**

## APPENDIX E — UPC OPEN CONTROLLER (cont)



**Fig. K — BT485 Terminator Installation**

To install a BT485 terminator, push the BT485 terminator, on to the BT485 connector located near the BACnet connector.  
NOTE: The BT485 terminator has no polarity associated with it.

To order a BT485 terminator, consult Commercial Products i-Vu® Open Control System Master Prices.

**MS/TP Wiring Recommendations** — Recommendations are shown in Tables H and I. The wire jacket and UL

temperature rating specifications list two acceptable alternatives. The Halar specification has a higher temperature rating and a tougher outer jacket than the SmokeGard specification, and it is appropriate for use in applications where the user is concerned about abrasion. The Halar jacket is also less likely to crack in extremely low temperatures.

NOTE: Use the specified type of wire and cable for maximum signal integrity.

**Table H — MS/TP Wiring Recommendations**

SPECIFICATION	RECOMMENDATION
<b>Cable</b>	Single twisted pair, low capacitance, CL2P, 22 AWG (7x30), TC foam FEP, plenum rated cable
<b>Conductor</b>	22 or 24 AWG stranded copper (tin plated)
<b>Insulation</b>	Foamed FEP 0.015 in. (0.381 mm) wall 0.060 in. (1.524 mm) O.D.
<b>Color code</b>	Black/White
<b>Twist Lay</b>	2 in. (50.8 mm) lay on pair 6 twists/foot (20 twists/meter) nominal
<b>Shielding</b>	Aluminum/Mylar shield with 24 AWG TC drain wire
<b>Jacket</b>	SmokeGard Jacket (SmokeGard PVC) 0.021 in. (0.5334 mm) wall 0.175 in. (4.445 mm) O.D. Halar Jacket (E-CTFE) 0.010 in. (0.254 mm) wall 0.144 in. (3.6576 mm) O.D.
<b>DC resistance</b>	15.2 Ohms/1000 feet (50 Ohms/km) nominal
<b>Capacitance</b>	12.5 pF/ft (41 pF/meter) nominal conductor to conductor
<b>Characteristic impedance</b>	100 Ohms nominal
<b>Weight</b>	12 lb/1000 feet (17.9 kg/km)
<b>UL Temperature Rating</b>	SmokeGard 167°F (75°C) Halar -40 to 302°F (-40 to 150°C)
<b>Voltage</b>	300 Vac, power limited
<b>Listing</b>	UL: NEC CL2P, or better

**LEGEND**

- AWG** — American Wire Gage
- CL2P** — Class 2 Plenum Cable
- DC** — Direct Current
- FEP** — Fluorinated Ethylene Polymer
- NEC** — National Electrical Code
- O.D.** — Outside Diameter
- TC** — Tinned Copper
- UL** — Underwriters Laboratories

## APPENDIX E — UPC OPEN CONTROLLER (cont)

**Table I — Open System Wiring Specifications and Recommended Vendors**

WIRING SPECIFICATIONS		RECOMMENDED VENDORS AND PART NUMBERS			
Wire Type	Description	Connect Air International	Belden	RMCORP	Contractors Wire and Cable
<b>MS/TP Network (RS-485)</b>	22 AWG, single twisted shielded pair, low capacitance, CL2P, TC foam FEP, plenum rated. See MS/TP Installation Guide for specifications.	W221P-22227	—	25160PV	CLP0520LC
	24 AWG, single twisted shielded pair, low capacitance, CL2P, TC foam FEP, plenum rated. See MS/TP Installation Guide for specifications.	W241P-2000F	82841	25120-OR	—
<b>Rnet</b>	4 conductor, unshielded, CMP, 18 AWG, plenum rated.	W184C-2099BLB	6302UE	21450	CLP0442

**LEGEND**

- AWG** — American Wire Gage
- CL2P** — Class 2 Plenum Cable
- CMP** — Communications Plenum Rated
- FEP** — Fluorinated Ethylene Polymer
- TC** — Tinned Copper

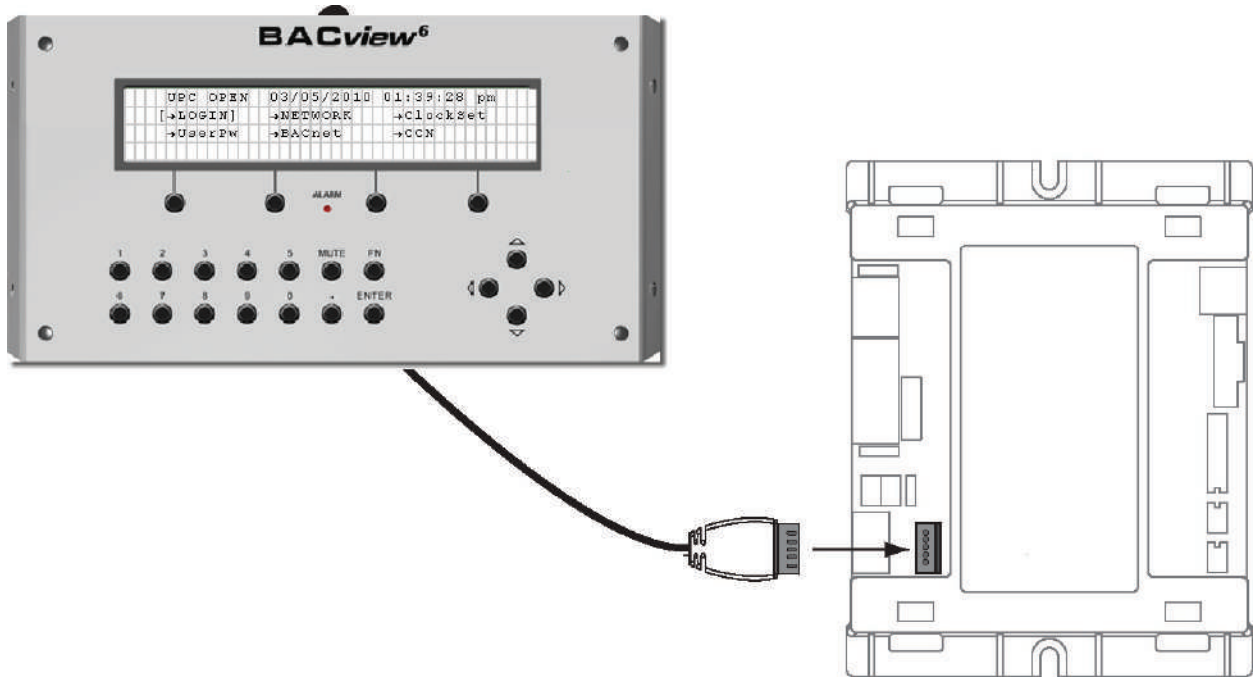
**Local access to the UPC Open** — The user can use a BACview<sup>6</sup> handheld keypad display unit or the Virtual BACview software as a local user interface to an Open controller. These items let the user access the controller network information. These are accessory items and do not come with the UPC Open controller.

The BACview<sup>6</sup> unit connects to the local access port on the UPC Open controller. See Fig. L. The BACview software must

be running on a laptop computer that is connected to the local access port on the UPC Open controller. The laptop will require an additional USB link cable for connection.

See the *BACview Installation and User Guide* for instructions on connecting and using the BACview<sup>6</sup> device.

To order a BACview<sup>6</sup> Handheld (BV6H), consult Commercial Products i-Vu Open Control System Master Prices.



**Fig. L — BACview<sup>6</sup> Device Connection**

## APPENDIX E — UPC OPEN CONTROLLER (cont)

**Configuring the UPC Open Controller's Properties** — The UPC Open device and *ComfortLink* controls must be set to the same CCN Address (Element) number and CCN Bus number. The factory default settings for CCN Element and CCN Bus number are 1 and 0 respectively.

If modifications to the default Element and Bus number are required, both the *ComfortLink* and UPC Open configurations must be changed.

The following configurations are used to set the CCN Address and Bus number in the *ComfortLink* controls. These configurations can be changed using the scrolling marquee display or accessory Navigator handheld device.

**Configuration**→**CCN**→**CCN.A** (CCN Address)

**Configuration**→**CCN**→**CCN.B** (CCN Bus Number)

The following configurations are used to set the CCN Address and Bus Number in the UPC Open controller. These configurations can be changed using the accessory BACview<sup>6</sup> display.

Navigation: BACview→CCN

Home: Element Comm Stat

Element: 1

Bus: 0

**Troubleshooting** — If there are problems wiring or addressing the UPC Open controller, contact Carrier Technical Support.

**COMMUNICATION LEDS** — The LEDs indicate if the controller is communicating with the devices on the network. See Tables J and K. The LEDs should reflect communication traffic based on the baud rate set. The higher the baud rate the more solid the LEDs become. See Fig. H for location of LEDs on UPC Open module.

**REPLACING THE UPC OPEN BATTERY** — The UPC Open controller's 10-year lithium CR2032 battery provides a minimum of 10,000 hours of data retention during power outages.

**IMPORTANT:** Power must be **ON** to the UPC Open when replacing the battery, or the date, time, and trend data will be lost.

Remove the battery from the controller, making note of the battery's polarity. Insert the new battery, matching the battery's polarity with the polarity indicated on the UPC Open controller.

**Table J — LED Status Indicators**

LED	STATUS
<b>Power</b>	Lights when power is being supplied to the controller. The UPC Open controller is protected by internal solid-state polyswitches on the incoming power and network connections. These polyswitches are not replaceable and will reset themselves if the condition that caused the fault returns to normal.
<b>Rx</b>	Lights when the controller receives data from the network segment; there is an Rx LED for Ports 1 and 2.
<b>Tx</b>	Lights when the controller transmits data to the network segment; there is an Rx LED for Ports 1 and 2.
<b>Run</b>	Lights based on controller status. See Table K.
<b>Error</b>	Lights based on controller status. See Table K.

**Table K — Run and Error LEDs Controller and Network Status Indication**

RUN LED	ERROR LED	STATUS
2 flashes per second	Off	Normal
2 flashes per second	2 flashes, alternating with Run LED	Five minute auto-restart delay after system error
2 flashes per second	3 flashes, then off	Controller has just been formatted
2 flashes per second	1 flash per second	Controller is alone on the network
2 flashes per second	On	Exec halted after frequent system errors or control programs halted
5 flashes per second	On	Exec start-up aborted, Boot is running
5 flashes per second	Off	Firmware transfer in progress, Boot is running
7 flashes per second	7 flashes per second, alternating with Run LED	Ten second recovery period after brownout
14 flashes per second	14 flashes per second, alternating with Run LED	Brownout

**APPENDIX E — UPC OPEN CONTROLLER (cont)**

**NETWORK POINTS LIST**

BACNET OBJECT ID	POINT NAME	READ ONLY	UNITS	DEFAULT VALUE	RANGE	BACNET OBJECT NAME	UNIT POINT
AV:9	Active Demand Limit	W	%	n/a	0-100	dem_lim_1	DEM_LIM
AV:10	Air Temp Lvg Supply Fan	R	°F	n/a	n/a	sat_1	SAT
AV:11	CEM AN1 4-20 ma J5,1-2	W	mA	n/a	0-20	cem4201_1	CEM4201
AV:12	CEM AN1 10K temp J5,1-2	W	°F	n/a	-40-240	cem10k1_1	CEM10K1
AV:13	CEM AN2 4-20 ma J5,3-4	W	mA	n/a	0-20	cem4202_1	CEM4202
AV:14	CEM AN2 10K temp J5,3-4	W	°F	n/a	-40-240	cem10k2_1	CEM10K2
AV:15	Temper Supply Air Setpt	W	°F	n/a	0-100	sasptemp_1	SASPTEMP
AV:16	BP PID Evaluation Time Level	W	min	1	0-10	bpperiod_1	BPPERIOD
AV:17	BP Setpoint Offset	W	in H2O	0.05	0-0.5	bps0_1	BPSO
AV:18	BP Threshold Adjustment	W	n/a	1	0.1-10	bpz_gain_1	BPZ_GAIN
AV:22	Capacity Load Factor	R	%	n/a	n/a	smz_1	SMZ
AV:23	Capacity Threshold Adj	W	n/a	1	0-10	z_gain_1	Z_GAIN
AV:24	Compressor A1 Run Hours	R	hr	n/a	n/a	hr_a1_1	HR_A1
AV:25	Compressor A1 Starts	R	n/a	n/a	n/a	cy_a1_1	CY_A1
AV:26	Compressor A1 Strikes	R	n/a	n/a	n/a	cmpa1str_1	CMPA1STR
AV:27	Compressor A1 Timeguard	R	n/a	n/a	n/a	cmpa1_tg_1	CMPA1_TG
AV:28	Compressor A2 Run Hours	R	hr	n/a	n/a	hr_a2_1	HR_A2
AV:29	Compressor A2 Starts	R	n/a	n/a	n/a	cy_a2_1	CY_A2
AV:30	Compressor A2 Strikes	R	n/a	n/a	n/a	cmpa2str_1	CMPA2STR
AV:31	Compressor A2 Timeguard	R	n/a	n/a	n/a	cmpa2_tg_1	CMPA2_TG
AV:32	Compressor B1 Run Hours	R	hr	n/a	n/a	hr_b1_1	HR_B1
AV:33	Compressor B1 Starts	R	n/a	n/a	n/a	cy_b1_1	CY_B1
AV:34	Compressor B1 Strikes	R	n/a	n/a	n/a	cmpb1str_1	CMPB1STR
AV:35	Compressor B1 Timeguard	R	n/a	n/a	n/a	cmpb1_tg_1	CMPB1_TG
AV:36	Compressor B2 Run Hours	R	hr	n/a	n/a	hr_b2_1	HR_B2
AV:37	Compressor B2 Starts	R	n/a	n/a	n/a	cy_b2_1	CY_B2
AV:38	Compressor B2 Strikes	R	n/a	n/a	n/a	cmpb2str_1	CMPB2STR
AV:39	Compressor B2 Timeguard	R	n/a	n/a	n/a	cmpb2_tg_1	CMPB2_TG
AV:40	Compressor Lockout Temp	W	°F	40	-20-55	oatlcomp_1	OATLCOMP
AV:41	Cool Trend Demand Level	W	°F	0.1	0.1-5	ctrendlv_1	CTRENDLV
AV:42	Cool Trend Time (secs)	W	sec	120	30-600	ctrendtm_1	CTRENDTM
AV:43	Ctl.Temp RAT,SPT or ZONE	R	°F	n/a	n/a	ctrltemp_1	CTRLTEMP
AV:44	Current Running Capacity	R	%	n/a	n/a	htsg_cap_1	HTSG_CAP
AV:45	DAQ PPM Fan Off Setpoint	W	n/a	200	0-2000	daqfnoff_1	DAQFNOFF
AV:46	DAQ PPM Fan On Setpoint	W	n/a	400	0-2000	daqfnon_1	DAQFNON
AV:49	Dehumidify Cool Setpoint	W	°F	45	40-55	dhcoolsp_1	DHCOOLSP
AV:50	Dehumidify RH Setpoint	W	%	55	10-90	dhrelhsp_1	DHRELHSP
AV:52	Demand Limit Select	W	n/a	0	0-3	dmd_ctrl_1	DMD_CTRL
AV:53	Demand Limit Sw.1 Setpt.	W	%	80	0-100	dlswsp1_1	DLSWSP1
AV:54	Demand Limit Sw.2 Setpt.	W	%	50	0-100	dlswsp2_1	DLSWSP2
AV:56	Diff.Air Quality in PPM	R	n/a	n/a	n/a	daq_1	DAQ
AV:58	Diff. AQ Responsiveness	W	n/a	0	-5-5	iaqreact_1	IAQREACT
AV:59	Dmd Level(-) Low Cool OFF	W	°F	1	0.5-2	dmdlcoff_1	DMDLCOFF
AV:60	Dmd Level(-) Low Heat OFF	W	°F	1	0.5-2	dmdlhoff_1	DMDLHOFF

See legend on page 183.

**APPENDIX E — UPC OPEN CONTROLLER (cont)**

**NETWORK POINTS LIST (cont)**

BACNET OBJECT ID	POINT NAME	READ ONLY	UNITS	DEFAULT VALUE	RANGE	BACNET OBJECT NAME	UNIT POINT
AV:61	Dmd Level(+) Hi Cool ON	W	°F	0.5	0.5-20	dmdhcon_1	DMDHCON
AV:62	Dmd Level(+) Hi Heat ON	W	°F	0.5	0.5-20	dmdhhon_1	DMDHHON
AV:63	Dmd Level Low Cool ON	W	°F	1.5	0.5-2	dmdlcon_1	DMDLCON
AV:64	Dmd Level Low Heat ON	W	°F	1.5	0.5-2	dmdlhon_1	DMDLHON
AV:66	Econo Current Min. Pos.	R	%	n/a	n/a	min_pos_1	MIN_POS
AV:67	Economizer Act. Cmd. Pos.	W	%	n/a	0-100	econocmd_1	ECONOCMD
AV:68	Economizer Control Point	R	°F	n/a	n/a	econpnt_1	ECONCPNT
AV:70	Economizer Max.Position	W	%	98	0-100	economax_1	ECONOMAX
AV:76	Evaporator Discharge Tmp	R	°F	n/a	n/a	edt_1	EDT
AV:77	Fan Mode	W	n/a	1	0-1	fan_mode_1	FAN_MODE
AV:78	Fan-Off Delay, Elec Heat	W	n/a	30	10-600	elec_fod_1	ELEC_FOD
AV:79	Fan-Off Delay, Gas Heat	W	n/a	45	45-600	gas_fod_1	GAS_FOD
AV:80	Fan-Off Delay, Mech Cool	W	sec	60	0-600	cool_fod_1	COOL_FOD
AV:83	Heat-Cool Setpoint Gap	W	°F	5	2-10	hcsp_gap_1	HCSP_GAP
AV:85	Heating Supply Air Setpt	W	°F	85	80-120	saspheat_1	SASPHEAT
AV:86	High BP Level	W	n/a	0.05	0-1	bphplvl_1	BPHPLVL
AV:87	Low BP Level	W	n/a	0.04	0-1	bplplvl_1	BPLPLVL
AV:93	IAQ Econo Override Pos.	W	%	100	0-100	iaqovpos_1	IAQOVPOS
AV:95	IAQ High Reference	W	n/a	2000	0-5000	iaqrefh_1	IAQREFH
AV:96	IAQ Low Reference	W	n/a	0	0-5000	iaqrefl_1	IAQREFL
AV:97	IAQ Min.Pos.Override	W	%	n/a	0-100	iaqminov_1	IAQMINOV
AV:98	IAQ Purge Duration	W	min	15	5-60	iaqptime_1	IAQPTIME
AV:99	IAQ Purge HiTemp Min Pos	W	%	35	0-100	iaqphtmp_1	IAQPHTMP
AV:100	IAQ Purge LoTemp Min Pos	W	%	10	0-100	iaqpltmp_1	IAQPLTMP
AV:101	IAQ Purge OAT Lockout	W	°F	50	35-70	iaqpntlo_1	IAQPNTLO
AV:102	LAT Limit Config	W	°F	10	0-20	htlatlim_1	HTLATLIM
AV:107	Maximum Heat Stages	R	n/a	n/a	n/a	htmaxstg_1	HTMAXSTG
AV:112	OAQ Lockout Value	W	n/a	0	0-2000	oaqlock_1	OAQLOCK
AV:113	OAQ - PPM Outdoor CO2	W	n/a	n/a	0-5000	oaq_1	OAQ
AV:114	Occupied Cool Mode End	R	°F	n/a	n/a	occl_end_1	OCCL_END
AV:115	Occupied Cool Mode Start	R	°F	n/a	n/a	occlstrt_1	OCCLSTRT
AV:116	Occupied Heat Mode End	R	°F	n/a	n/a	ocht_end_1	OCHT_END
AV:117	Occupied Heat Mode Start	R	°F	n/a	n/a	ochtstrt_1	OCHTSTRT
AV:118	Outside Air Humidity Ratio	R	n/a	n/a	n/a	oa_humr_1	OA_HUMR
AV:119	Outside Air Relative Humidity	W	%	n/a	0-100	oarh_1	OARH
AV:120	Override Time Limit	W	hr	1	0-4	otl_1	OTL
AV:121	Power Exhaust Motors	W	n/a	1	0-2	pwrn_1	PWRM
AV:122	Power Exhaust On Setp.1	W	%	35	0-100	pes1_1	PES1
AV:123	Power Exhaust On Setp.2	W	%	75	0-100	pes2_1	PES2
AV:130	Remote Switch Config	W	n/a	0	0-3	rmtncfg_1	RMTINCFG
AV:131	Reset Limit	W	°F	10	0-20	limt_1	LIMIT
AV:132	Reset Ratio	W	n/a	2	0-10	rtio_1	RTIO
AV:133	Return Air Enthalpy	R	n/a	n/a	n/a	rae_1	RAE

See legend on page 183.

**APPENDIX E — UPC OPEN CONTROLLER (cont)**

**NETWORK POINTS LIST (cont)**

BACNET OBJECT ID	POINT NAME	READ ONLY	UNITS	DEFAULT VALUE	RANGE	BACNET OBJECT NAME	UNIT POINT
AV:134	Return Air Relative Humidity	W	%	n/a	0-100	rarh_1	RARH
AV:135	Return Air Temperature	W	°F	n/a	-40-240	rat_1	RAT
AV:136	Schedule Number	W	n/a	0	0-99	schednum_1	SCHEDNUM
AV:137	Space Temperature	W	°F	n/a	-40-240	spt_1	SPT
AV:138	Space Temperature Offset	W	°F	n/a	-10-10	spto_1	SPTO
AV:139	Space Temp Offset Range	W	°F	5	1-10	spto_rng_1	SPTO_RNG
AV:143	SP Reset Limit	W	n/a	0.75	0-2	sprlimit_1	SPRLIMIT
AV:144	SP Reset Ratio	W	n/a	0.2	0-2	sprratio_1	SPRRATIO
AV:150	Staged Gas LAT 1	R	°F	n/a	n/a	lat1sgas_1	LAT1SGAS
AV:151	Staged Gas LAT 2	R	°F	n/a	n/a	lat2sgas_1	LAT2SGAS
AV:152	Staged Gas LAT 3	R	°F	n/a	n/a	lat3sgas_1	LAT3SGAS
AV:153	Staged Gas LAT Sum	R	°F	n/a	n/a	lat_sgas_1	LAT_SGAS
AV:154	Staged Gas Limit Sw Temp	R	°F	n/a	n/a	limswtmp_1	LIMSWTMP
AV:155	Startup Delay Time	W	sec	0	0-900	delay_1	DELAY
AV:156	Stat. Pres. Reset Config	W	n/a	0	0-4	sprstcfg_1	SPRSTCFG
AV:157	Static Pressure Reset	W	n/a	n/a	0-15	spreset_1	SPRESET
AV:158	Supply Air Setpt. Reset	W	°F	n/a	0-20	sasprset_1	SASPRSET
AV:159	Temp Comp Start Cool Factor	W	min	0	0-60	tcstcool_1	TCSTCOOL
AV:160	Temp Comp Start Heat Factor	W	min	0	0-60	tcstheat_1	TCSTHEAT
AV:161	Tempering in Cool SASP	W	n/a	5	5-75	tempcool_1	TEMPCOOL
AV:162	Tempering Purge SASP	W	n/a	50	-20-80	temppurg_1	TEMPPURG
AV:163	Tempering Vent Occ SASP	W	n/a	65	-20-80	tempvocc_1	TEMPVOCC
AV:164	Temper Vent Unocc	W	n/a	50	-20-80	tempvunc_1	TEMPVUNC
AV:165	Supply Fan VFD Speed	W	%	n/a	0-100	sf_vfd_output_1	SFVFDST
AV:166	Un.Ec.Free Cool OAT Lock	W	°F	50	40-70	uefcntlo_1	UEFCNTLO
AV:168	Unoccupied Cool Mode End	R	°F	n/a	n/a	uccl_end_1	UCCL_END
AV:169	Unoccupied Cool Mode Start	R	°F	n/a	n/a	ucclstrt_1	UCCLSTRT
AV:170	Unoccupied Heat Mode End	R	°F	n/a	n/a	ucht_end_1	UCHT_END
AV:171	Unoccupied Heat Mode Start	R	°F	n/a	n/a	uchtstrt_1	UCHTSTRT
AV:172	Unoc Econ Free Cool Cfg	W	n/a	0	0-2	uefc_cfg_1	UEFC_CFG
AV:173	Unoc Econ Free Cool Time	W	min	120	0-720	uefctime_1	UEFCTIME
AV:179	User Determined OAQ	W	n/a	400	0-5000	oaq_user_1	OAQ_USER
AV:180	VAV Occ. Cool Off Delta	W	°F	2	1-25	vavocoff_1	VAVOCOFF
AV:181	VAV Occ. Cool On Delta	W	°F	3.5	0-25	vavocon_1	VAVOCON
AV:182	VAV Unocc Fan Retry Time	W	min	60	0-720	sampmins_1	SAMPMINS
AV:183	Vent Reheat RAT Offset	W	°F	0	0-8	dhvraoff_1	DHVRAOFF
AV:184	Vent Reheat Setpoint	W	°F	70	55-95	dhvht_sp_1	DHVHT_SP
AV:185	Vent Reheat Setpt Select	W	n/a	0	0-1	dhvhtcfg_1	DHVHTCFG
AV:186	VFD/Act. Fire Speed/Pos.	W	%	100	0-100	blgpfso_1	BLDGPFSO
AV:187	VFD Fire Speed Override	W	%	100	0-100	statpfso_1	STATPFSO
AV:188	VFD Maximum Speed	W	%	100	0-100	statpmax_1	STATPMAX
AV:189	VFD Minimum Speed	W	%	20	0-100	statpmin_1	STATPMIN
AV:1003	Outside Air Temperature	W	°F	n/a	-40-240	oat_1	OAT

See legend on page 183.

**APPENDIX E — UPC OPEN CONTROLLER (cont)**

**NETWORK POINTS LIST (cont)**

BACNET OBJECT ID	POINT NAME	READ ONLY	UNITS	DEFAULT VALUE	RANGE	BACNET OBJECT NAME	UNIT POINT
AV:1009	IAQ - PPM Indoor CO2	W	n/a	n/a	0-5000	iaq_1	IAQ
AV:1016	Static Pressure	R	in H2O	n/a	n/a	static_press_1	SP
AV:1022	HVAC Mode Numerical Form	R	n/a	n/a	n/a	hvac_mode_1	MODEHVAC
AV:1023	Current Running Capacity	R	%	n/a	n/a	cool_capacity_1	CAPTOTAL
AV:1024	Cooling Control Point	R	°F	n/a	n/a	cool_ctrl_point_1	COOLCPNT
AV:1025	Heating Control Point	R	°F	n/a	n/a	heat_ctrl_point_1	HEATCPNT
AV:1027	Leaving Air Temperature	R	°F	n/a	n/a	lvq_air_temperature_1	LAT
AV:1028	Economizer Act. Curr. Pos	R	%	n/a	n/a	econ_pos_1	ECONOPOS
AV:1030	Controlling Return Temp	W	°F	n/a	-40-240	ra_temp_1	RETURN_T
AV:1070	Building Pressure	R	in H2O	n/a	n/a	bldg_static_press_1	BP
AV:1500	Mixed Air Temperature	R	°F	n/a	n/a	ma_temp_1	MAT
AV:1600	Cir A Suction Pressure	R	psig	n/a	n/a	suction_press_a_1	SP_A
AV:1601	Cir A Discharge Pressure	R	psig	n/a	n/a	discharge_press_a_1	DP_A
AV:1602	Cir A Sat. Condensing Temperature	R	°F	n/a	n/a	sat_cond_temp_a_1	SCTA
AV:1603	Cir A Sat. Suction Temperature	R	°F	n/a	n/a	sat_suction_temp_a_1	SSTA
AV:1604	Cir B Suction Pressure	R	psig	n/a	n/a	suction_press_b_1	SP_B
AV:1605	Cir B Discharge Pressure	R	psig	n/a	n/a	discharge_press_b_1	DP_B
AV:1606	Cir B Sat. Condensing Temperature	R	°F	n/a	n/a	sat_cond_temp_b_1	SCTB
AV:1607	Cir B Sat. Suction Temperature	R	°F	n/a	n/a	sat_suction_temp_b_1	SSTB
AV:2003	Requested Heat Stage	R	n/a	n/a	n/a	heat_run_1	HT_STAGE
AV:2007	Controlling Space Temp	W	°F	n/a	-40-240	space_temp_1	SPACE_T
AV:2050	Supply Fan VFD Speed	R	%	n/a	n/a	sfvfdtst_1	SFAN_VFD
AV:2075	Exhaust Fan VFD Speed	R	%	n/a	n/a	ef_vfd_output_1	EFAN_VFD
AV:2901	User Defined Analog 1	n/a	n/a	n/a	n/a	user_analog_1_1	n/a
AV:2902	User Defined Analog 2	n/a	n/a	n/a	n/a	user_analog_2_1	n/a
AV:2903	User Defined Analog 3	n/a	n/a	n/a	n/a	user_analog_3_1	n/a
AV:2904	User Defined Analog 4	n/a	n/a	n/a	n/a	user_analog_4_1	n/a
AV:2905	User Defined Analog 5	n/a	n/a	n/a	n/a	user_analog_5_1	n/a
AV:3001	Cooling Occupied Setpoint	W	°F	75	40-99	occ_cl_stpt_1	OCSP
AV:3002	Heating Occupied Setpoint	W	°F	68	40-99	occ_ht_stpt_1	OHSP
AV:3003	Cooling Unoccupied Setpoint	W	°F	90	40-99	unocc_cl_stpt_1	UCSP
AV:3004	Heating Unoccupied Setpoint	W	°F	55	40-99	unocc_ht_stpt_1	UHSP
AV:3007	Supply Air Setpoint	W	°F	55	45-75	sa_temp_stpt_1	SASP
AV:3016	IAQ Demand Vent Min.Pos.	W	%	0	0-100	iaq_min_pos_1	IAQMINP
AV:3050	Static Pressure Setpoint	W	in H2O	1.5	0-5	sa_static_stpt_1	SPSP
AV:3070	Building Pressure Setp.	W	in H2O	0.05	-0.25-0.25	bldg_press_stpt_1	BPSP
AV:4005	Economizer Min.Position	W	%	5	0-100	econ_min_1	ECONOMIN
AV:9008	High OAT Lockout Temp	W	°F	60	-40-120	econ_oat_lockout_1	OAT_LOCK

See legend on page 183.



**APPENDIX E — UPC OPEN CONTROLLER (cont)**

**NETWORK POINTS LIST (cont)**

BACNET OBJECT ID	POINT NAME	READ ONLY	UNITS	DEFAULT VALUE	RANGE	BACNET OBJECT NAME	UNIT POINT
<b>BV:9</b>	Alarm State	R	n/a	n/a	n/a	alm_1	ALM
<b>BV:10</b>	Capacity Clamp Mode	R	n/a	n/a	n/a	capmode_1	CAPMODE
<b>BV:11</b>	Fan request from IGC	R	n/a	n/a	n/a	igcfan_1	IGCFAN
<b>BV:12</b>	Comp A1 Locked Out ?	R	n/a	n/a	n/a	cmpa1lok_1	CMPA1LOK
<b>BV:13</b>	Comp A2 Locked Out ?	R	n/a	n/a	n/a	cmpa2lok_1	CMPA2LOK
<b>BV:14</b>	Comp B1 Locked Out ?	R	n/a	n/a	n/a	cmpb1lok_1	CMPB1LOK
<b>BV:15</b>	Comp B2 Locked Out ?	R	n/a	n/a	n/a	cmpb2ok_1	CMPB2LOK
<b>BV:16</b>	Compressor A1 Relay	R	n/a	n/a	n/a	cmpa1_1	CMPA1
<b>BV:17</b>	Compressor A2 Relay	R	n/a	n/a	n/a	cmpa2_1	CMPA2
<b>BV:18</b>	Compressor B1 Relay	R	n/a	n/a	n/a	cmpb1_1	CMPB1
<b>BV:19</b>	Compressor B2 Relay	R	n/a	n/a	n/a	cmpb2_1	CMPB2
<b>BV:20</b>	Cool Mode Not In Effect?	R	n/a	n/a	n/a	cool_off_1	COOL_OFF
<b>BV:21</b>	Override Modes in Effect	R	n/a	n/a	n/a	modes_1	MODES
<b>BV:22</b>	Supply Fan not on 30s ?	R	n/a	n/a	n/a	sfonstat_1	SFONSTAT
<b>BV:25</b>	DBC - OAT Lockout?	R	n/a	n/a	n/a	dbc_stat_1	DBC_STAT
<b>BV:26</b>	DCV Resetting Min Pos	R	n/a	n/a	n/a	modeadc_1	MODEADCV
<b>BV:27</b>	DDBC- OAT > RAT Lockout?	R	n/a	n/a	n/a	ddbcstat_1	DDBCSTAT
<b>BV:28</b>	DEC - Diff.Enth.Lockout?	R	n/a	n/a	n/a	dec_stat_1	DEC_STAT
<b>BV:29</b>	Dehumid. Disabled Econ.?	R	n/a	n/a	n/a	dhdisabl_1	DHDISABL
<b>BV:30</b>	Dehumidify Input	W	n/a	n/a	0-1	dhdiscin_1	DHDISCIN
<b>BV:31</b>	Demand Limit In Effect	R	n/a	n/a	n/a	modedmlt_1	MODEDMLT
<b>BV:32</b>	DEW - OA Dewpt.Lockout?	R	n/a	n/a	n/a	dew_stat_1	DEW_STAT
<b>BV:34</b>	Econ Act. Unavailable?	R	n/a	n/a	n/a	econunav_1	ECONUNAV
<b>BV:35</b>	Econ disable in DH mode?	W	n/a	1	0-1	dhecdisa_1	DHECDISA
<b>BV:36</b>	Economizer Active?	R	n/a	n/a	n/a	ecactive_1	ECACTIVE
<b>BV:37</b>	Economizer Control Input	W	n/a	n/a	0-1	ecosw_1	ECOSW
<b>BV:38</b>	Economizer Forced ?	R	n/a	n/a	n/a	econforc_1	ECONFORC
<b>BV:41</b>	Econo Position Override	W	n/a	n/a	0-1	ecooride_1	ECORIDE
<b>BV:42</b>	Econ Recovery Hold Off?	R	n/a	n/a	n/a	econheld_1	ECONHELD
<b>BV:44</b>	EDT Sensor Bad ?	R	n/a	n/a	n/a	edt_stat_1	EDT_STAT
<b>BV:45</b>	Emergency Stop	W	n/a	n/a	0-1	emstop_1	EMSTOP
<b>BV:46</b>	Enable Compressor A1	W	n/a	Enable	0-1	cmpa1ena_1	CMPA1ENA
<b>BV:47</b>	Enable Compressor A2	W	n/a	Enable	0-1	cmpa2ena_1	CMPA2ENA
<b>BV:48</b>	Enable Compressor B1	W	n/a	Enable	0-1	cmpb1ena_1	CMPB1ENA
<b>BV:49</b>	Enable Compressor B2	W	n/a	Enable	0-1	cmpb2ena_1	CMPB2ENA
<b>BV:50</b>	Fan Fail Shuts Down Unit	W	n/a	0	0-1	sfs_shut_1	SFS_SHUT
<b>BV:52</b>	Heat Relay 1	R	n/a	n/a	n/a	hs1_1	HS1
<b>BV:53</b>	Heat Relay 2	R	n/a	n/a	n/a	hs2_1	HS2
<b>BV:54</b>	High BP Override	R	n/a	n/a	n/a	bphpovrd_1	BPHPOVRD
<b>BV:55</b>	Hi Limit Switch Tmp Mode	R	n/a	n/a	n/a	limtmode_1	LIMTMODE
<b>BV:56</b>	IAQ Pre-Occ Purge Active	R	n/a	n/a	n/a	modeiqpg_1	MODEIQPG
<b>BV:57</b>	IAQ Purge	W	n/a	0	0-1	iaqpurge_1	IAQPURGE
<b>BV:58</b>	LAT Cutoff Mode	R	n/a	n/a	n/a	latcmode_1	LATCMODE

See legend on page 183.

**APPENDIX E — UPC OPEN CONTROLLER (cont)**

**NETWORK POINTS LIST (cont)**

BACNET OBJECT ID	POINT NAME	READ ONLY	UNITS	DEFAULT VALUE	RANGE	BACNET OBJECT NAME	UNIT POINT
<b>BV:59</b>	Local Machine Disable	W	n/a	No	0-1	unitstop_1	UNITSTOP
<b>BV:60</b>	Low BP Override	R	n/a	n/a	n/a	bplpovrd_1	BPLPOVRD
<b>BV:61</b>	Low Temp Cap Override	R	n/a	n/a	n/a	low_temp_1	LOW_TEMP
<b>BV:63</b>	Mech Cooling Locked Out	R	n/a	n/a	n/a	modelock_1	MODELOCK
<b>BV:64</b>	Min. Load Valve (HGBP)	R	n/a	n/a	n/a	mlv_1	MLV
<b>BV:67</b>	OAEC- OA Enth Lockout?	R	n/a	n/a	n/a	oaecstat_1	OAECSTAT
<b>BV:68</b>	OAQ Lockout In Effect ?	R	n/a	n/a	n/a	oaqlockd_1	OAQLOCKD
<b>BV:69</b>	OAT Sensor Bad ?	R	n/a	n/a	n/a	oat_stat_1	OAT_STAT
<b>BV:70</b>	Occupied Heating Enabled	W	n/a	No	0-1	htoccena_1	HTOCCENA
<b>BV:72</b>	Power Exhaust Relay A	R	n/a	n/a	n/a	pe_a_1	PE_A
<b>BV:73</b>	Power Exhaust Relay B	R	n/a	n/a	n/a	pe_b_1	PE_B
<b>BV:74</b>	Power Exhaust Relay C	R	n/a	n/a	n/a	pe_c_1	PE_C
<b>BV:75</b>	Pull Down Cap Override	R	n/a	n/a	n/a	pulldown_1	PULLDOWN
<b>BV:76</b>	Relay 3 W1 Gas Valve 2	R	n/a	n/a	n/a	hs3_1	HS3
<b>BV:77</b>	Relay 4 W2 Gas Valve 2	R	n/a	n/a	n/a	hs4_1	HS4
<b>BV:78</b>	Relay 5 W1 Gas Valve 3	R	n/a	n/a	n/a	hs5_1	HS5
<b>BV:79</b>	Relay 6 W2 Gas Valve 3	R	n/a	n/a	n/a	hs6_1	HS6
<b>BV:80</b>	Remote Econ. Disabled ?	R	n/a	n/a	n/a	econdisa_1	ECONDISA
<b>BV:81</b>	Remote Input State	W	n/a	n/a	0-1	rmtin_1	RMTIN
<b>BV:86</b>	Slow Change Cap Override	R	n/a	n/a	n/a	slo_chng_1	SLO_CHNG
<b>BV:87</b>	Soft Stop Request	W	n/a	n/a	0-1	softstop_1	SOFTSTOP
<b>BV:93</b>	Supply Air Reset	R	n/a	n/a	n/a	modesars_1	MODESARS
<b>BV:94</b>	Supply Fan Relay	R	n/a	n/a	n/a	sfan_rly_1	SFAN_RLY
<b>BV:95</b>	Supply Fan Status Switch	W	n/a	n/a	0-1	sfs_1	SFS
<b>BV:96</b>	Temp Compensated Start	R	n/a	n/a	n/a	modetcst_1	MODETCST
<b>BV:97</b>	Timed Override In Effect	R	n/a	n/a	n/a	modetovr_1	MODETOVR
<b>BV:98</b>	Timed-Override in Effect	R	n/a	n/a	n/a	overlast_1	OVERLAST
<b>BV:99</b>	TSTAT Both Heat and Cool	W	n/a	No	0-1	tstatall_1	TSTATALL
<b>BV:1005</b>	Fire Shutdown Input	W	n/a	n/a	0-1	firedown_status_1	FSD
<b>BV:1006</b>	Demand Limit Switch 1	W	n/a	n/a	0-1	dmd_sw1_1	DMD_SW1
<b>BV:1007</b>	Demand Limit Switch 2	W	n/a	n/a	0-1	dmd_sw2_1	DMD_SW2
<b>BV:1010</b>	Remote Economizer Enable	W	n/a	n/a	0-1	remote_econ_enable_1	ECONENBL
<b>BV:1017</b>	Thermostat Y1 Input	W	n/a	n/a	0-1	y1_input_1	Y1
<b>BV:1018</b>	Thermostat Y2 Input	W	n/a	n/a	0-1	y2_input_1	Y2
<b>BV:1019</b>	Thermostat W1 Input	W	n/a	n/a	0-1	w1_input_1	W1
<b>BV:1020</b>	Thermostat W2 Input	W	n/a	n/a	0-1	w2_input_1	W2
<b>BV:1021</b>	Thermostat G Input	W	n/a	n/a	0-1	g_input_1	G
<b>BV:1026</b>	Heat Interlock Relay	W	n/a	n/a	0-1	heat_interlock_relay_1	HIR
<b>BV:1050</b>	IAQ - Discrete Input	W	n/a	n/a	0-1	iaq_status_1	IAQIN

See legend on page 183.

**APPENDIX E — UPC OPEN CONTROLLER (cont)**

**NETWORK POINTS LIST (cont)**

BACNET OBJECT ID	POINT NAME	READ ONLY	UNITS	DEFAULT VALUE	RANGE	BACNET OBJECT NAME	UNIT POINT
BV:1052	Filter Status Input	W	n/a	n/a	0-1	filter_status_1	FLTS
BV:1060	Evacuation Input	W	n/a	n/a	0-1	smk_evac_1	EVAC
BV:1061	Pressurization Input	W	n/a	n/a	0-1	smk_press_1	PRES
BV:1062	Smoke Purge Input	W	n/a	n/a	0-1	smk_purg_1	PURG
BV:2001	Supply Fan State	R	n/a	n/a	n/a	sfan_1	SFAN
BV:2004	Supply Fan Request	W	n/a	n/a	0-1	sfan_forc_1	SFANFORC
BV:2008	Occupied?	W	n/a	n/a	0-1	occ_status_1	OCCUPIED
BV:2012	Condenser Fan Circuit A	R	n/a	n/a	n/a	cond_fan_a_1	CONDFANA
BV:2013	Condenser Fan Circuit B	R	n/a	n/a	n/a	cond_fan_b_1	CONDFANB
BV:2014	Remote Alarm/Aux Relay	W	n/a	n/a	0-1	aux_relay_1	ALRM
BV:2911	User Defined Binary 1	n/a	n/a	n/a	n/a	user_binary_1_1	n/a
BV:2912	User Defined Binary 2	n/a	n/a	n/a	n/a	user_binary_2_1	n/a
BV:2913	User Defined Binary 3	n/a	n/a	n/a	n/a	user_binary_3_1	n/a
BV:2914	User Defined Binary 4	n/a	n/a	n/a	n/a	user_binary_4_1	n/a
BV:2915	User Defined Binary 5	n/a	n/a	n/a	n/a	user_binary_5_1	n/a
BV:2999	Element Comm Status	n/a	n/a	n/a	n/a	element_stat_1	n/a

**LEGEND**

<b>BP</b>	— Building Pressure
<b>CEM</b>	— Controls Expansion Module
<b>DAQ</b>	— Differential Air Quality
<b>DBC</b>	— Dry Bulb Changeover
<b>DCV</b>	— Demand Controlled Ventilation
<b>DDBC</b>	— Differential Dry Bulb Changeover
<b>DEC</b>	— Differential Enthalpy Changeover
<b>DH</b>	— Dehumidification
<b>EDT</b>	— Evaporator Discharge Temperature
<b>IAQ</b>	— Indoor Air Quality
<b>IGC</b>	— Integrated Gas Control
<b>LAT</b>	— Leaving Air Temperature
<b>n/a</b>	— Not Available
<b>OAEC</b>	— Outdoor Air Enthalpy Changeover
<b>OAQ</b>	— Outdoor Air Quality
<b>OAT</b>	— Outdoor Air Temperature
<b>PID</b>	— Proportional, Integral, Derivative
<b>R</b>	— Read
<b>RAT</b>	— Return Air Temperature
<b>RH</b>	— Relative Humidity
<b>SASP</b>	— Supply Air Set Point
<b>SP</b>	— Setpoint
<b>SPT</b>	— Space Temperature
<b>TSTAT</b>	— Thermostat
<b>VAV</b>	— Variable Air Volume
<b>VFD</b>	— Variable Frequency Drive
<b>W</b>	— Write

## INDEX

- Accessory control components 125
- Accessory installation 7
- Accessory Navigator™ display 4, 125
- Airflow control during
  - fire-smoke modes 67
- Alarm output 31
- Alarms and alerts 94
- Alert limit configuration 73
- Auto view of run status 91
- Basic control usage 4-7
- Building pressure configuration 64
- Building pressure control 64
- Carrier Comfort Network® (CCN) System 72
- CCN tables and display 5
- CCN tables 149-161
- Cleaning 129
- ComfortLink controls 4
- Complete unit stoppage 78
- Compressor run hours display table 92
- Compressor starts display table 92
- Condenser-fan adjustment 133
- Controls 7
- Controls operation 5, 32-76
- Controls quick start 27-29
- Controls set point and configuration
  - log CL-1 to CL-5
- Conventions used in this manual 3
- Cool mode selection process 40
- Cooling 30
- Cooling control 37
- Cooling mode diagnostic help 46
- Crankcase heaters 7
- Dehumidification and reheat 70
- Demand controlled ventilation control 31
- Demand limit control 31, 48
- Dirty filter switch 60
- Discrete switch logic configuration 74
- Display configuration 75
- Economizer 61
- Economizer diagnostic help 63
- Economizer integration with
  - mechanical cooling 50
- Economizer operation 61
- Economizer options 28
- Economizer run status 91
- Evacuation mode 67
- Evaporator fan 7, 131, 132
- Exhaust options 29
- Factory-installed components 102
- Fan status monitoring 60
- Fans 30
- Filter drier 140
- Fire shutdown mode 67
- Fire-smoke inputs 67
- Four-inch filter replacement 133
- Forcing inputs and outputs 91
- Gas heat (48A only) 7
- Gas valve adjustment (48A only) 133
- Generics table 7
- Head pressure control 49
- Heat mode diagnostic help 52
- Heat mode selection process 51
- Heating 30
- Heating control 50
- Hot gas bypass 76
- HVAC modes 33
- Independent outputs 30
- Indoor air quality control 67
- Indoor air quality options 29
- Internal wiring 7
- Local display tables 141-148
- Lubrication 131
- Main burners 140
- Major system components 102-128
- Mode selection 171
- Mode trip helper 92
- Modes 32
- Multi-stage constant volume units with
  - mechanical thermostat 28
- Multi-stage constant volume units
  - with space sensor 28
- Power failure 133
- Pressurization mode 67
- Programming operating schedules 29
- Refrigerant charge 133
- Remote control switch input 75
- Remote switch 31
- Replacement parts 140
- Restart procedure 78
- Run status menu 91
- Safety considerations 2, 3
- Scrolling marquee 4, 123
- Sensor trim configuration 73
- Service 129-140
- Service access 129
- Service analysis 78
- Service test 29, 30
- Service test mode logic 29
- Single circuit stoppage 78
- Smoke control modes 67
- Smoke purge mode 67
- Software version numbers
  - display table 92
- Space temperature offset 76
- Staged gas heating control 54-56
- Start-up 7-27
- Static pressure control 57
- Static pressure reset 59
- SumZ cooling algorithm 46
- Supply air reset 31
- Supply fan status monitoring logic 60
- System modes 33
- System Pilot™ interface 5
- Temperature compensated start 71
- Temperature compensated start logic 71
- Thermistor troubleshooting 78
- Thermostat 31
- Thermostatic expansion valve (TXV) 133
- Third party control 31, 32
- Time clock configuration 76-78
- Transducer troubleshooting 79
- Troubleshooting 78-102
- Two-stage constant volume units
  - with mechanical thermostat 27
- Two-stage constant volume units
  - with space sensor 27
- Unit Configuration submenu 35
- Unit preparation 7
- Unit setup 7
- Unit staging tables 43-45
- Unit start-up checklist CL-6
- Unoccupied economizer free cooling 62
- UPC Open controller 172-183
- Variable air volume units using return
  - air sensor or space temperature sensor 28
- VFD control 31
- VFD information 162-170

## CONTROLS SET POINT AND CONFIGURATION LOG

<b>MODEL NUMBER:</b>		<b>Software Version</b>	
<b>SERIAL NUMBER:</b>		<b>MBB</b>	CESR131343--
<b>DATE:</b>		<b>RCB</b>	CESR131249--
<b>TECHNICIAN:</b>		<b>ECB</b>	CESR131249--
		<b>NAVI</b>	CESR131227--
		<b>SCB</b>	CESR131226--
		<b>CEM</b>	CESR131174--
		<b>MARQ</b>	CESR131171--

ITEM	EXPANSION	RANGE	DEFAULT	ENTRY
<b>UNIT</b>	UNIT CONFIGURATION			
→ <b>C.TYP</b>	Machine Control Type	1 - 6 (multi-text strings)	4	
→ <b>CV.FN</b>	Fan Mode (0=Auto, 1=Cont)	0 - 1 (multi-text strings)	1	
→ <b>RM.CF</b>	Remote Switch Config	0 - 3 (multi-text strings)	0	
→ <b>CEM</b>	CEM Module Installed	Yes/No	No	
→ <b>TCS.C</b>	Temp.Cmp.Strt.Cool Factr	0 - 60 min	0	
→ <b>TCS.H</b>	Temp.Cmp.Strt.Heat Factr	0 - 60 min	0	
→ <b>SFS.S</b>	Fan Fail Shuts Down Unit	Yes/No	No	
→ <b>SFS.M</b>	Fan Stat Monitoring Type	0 - 2 (multi-text strings)	0	
→ <b>VAV.S</b>	VAV Unocc.Fan Retry Time	0 - 720 min	50	
→ <b>SIZE</b>	Unit Size (20-60)	20 - 60	20	
→ <b>DP.XR</b>	Disch.Press. Transducers	Yes/No	No	
→ <b>SP.XR</b>	Suct. Pres. Trans. Type	0 - 1 (multi-text strings)	0	
→ <b>RFG.T</b>	Refrig: 0=R22 1=R410A	0 - 1 (multi-text strings)	1	
→ <b>CND.T</b>	Cnd HX Typ:0=RTPF 1=MCHX	0 - 1 (multi-text strings)	0	
→ <b>MAT.S</b>	MAT Calc Config	0 - 2 (multi-text strings)	1	
→ <b>MAT.R</b>	Reset MAT Table Entries?	Yes/No	No	
→ <b>MAT.D</b>	MAT Outside Air Default	0-100%	20	
→ <b>ALTI</b>	Altitude.....in feet:	0 - 60000	0	
→ <b>DLAY</b>	Startup Delay Time	0 - 900 sec	0	
→ <b>STAT</b>	TSTAT_Both Heat and Cool	Yes/No	No	
→ <b>AUX.R</b>	Auxiliary Relay Config	0 - 3	0	
→ <b>SENS</b>	INPUT SENSOR CONFIG			
→ <b>SENS→SPT.S</b>	Space Temp Sensor	Enable/Disable	Disable	
→ <b>SENS→SP.O.S</b>	Space Temp Offset Sensor	Enable/Disable	Disable	
→ <b>SENS→SP.O.R</b>	Space Temp Offset Range	1 - 10	5	
→ <b>SENS→RRH.S</b>	Return Air RH Sensor	Enable/Disable	Disable	
→ <b>SENS→FLT.S</b>	Filter Stat.Sw.Enabled ?	Enable/Disable	Disable	
<b>COOL</b>	COOLING CONFIGURATION			
→ <b>Z.GN</b>	Capacity Threshold Adjst	-10 - 10	1	
→ <b>MC.LO</b>	Compressor Lockout Temp	-20 - 55 dF	40	
→ <b>C.FOD</b>	Fan-Off Delay, Mech Cool	0 - 600 sec	60	
→ <b>MLV</b>	Min. Load Valve? (HGBP)	Yes/No	No	
→ <b>M.M.</b>	Motor Master Control	Yes/No	No	
→ <b>HPSP</b>	Head Pressure Setpoint	80 - 150 dF	113	
→ <b>A1.EN</b>	Enable Compressor A1	Enable/Disable	Enable	
→ <b>A2.EN</b>	Enable Compressor A2	Enable/Disable	Enable	
→ <b>B1.EN</b>	Enable Compressor B1	Enable/Disable	Enable	
→ <b>B2.EN</b>	Enable Compressor B2	Enable/Disable	Enable	
→ <b>CS.A1</b>	CSB A1 Feedback Alarm	Enable/Disable	Enable	
→ <b>CS.A2</b>	CSB A2 Feedback Alarm	Enable/Disable	Enable	
→ <b>CS.B1</b>	CSB B1 Feedback Alarm	Enable/Disable	Enable	
→ <b>CS.B2</b>	CSB B2 Feedback Alarm	Enable/Disable	Enable	
→ <b>REV.R</b>	Rev Rotation Verified ?	Yes/No	No	
→ <b>H.SST</b>	Hi SST Alert DelayTime	5 - 30 min	10	
<b>EDT.R</b>	EVAP.DISCHRG TEMP RESET			
→ <b>RS.CF</b>	EDT Reset Configuration	0 - 3 (multi-text strings)	0	
→ <b>RTIO</b>	Reset Ratio	0 - 10	2	
→ <b>LIMIT</b>	Reset Limit	0 - 20 ^F	10	
→ <b>RES.S</b>	EDT 4-20 ma Reset Input	Enable/Disable	Disable	

Manufacturer reserves the right to discontinue, or change at any time, specifications or designs without notice and without incurring obligations.

ITEM	EXPANSION	RANGE	DEFAULT	ENTRY
<b>HEAT</b>	HEATING CONFIGURATION			
→HT.CF	Heating Control Type	0 - 4	0	
→HT.SP	Heating Supply Air Setpt	80 - 120 dF	85	
→OC.EN	Occupied Heating Enabled	Yes/No	No	
→LAT.M	MBB Sensor Heat Relocate	Yes/No	No	
→G.FOD	Fan-Off Delay, Gas Heat	45-600	45	
→E.FOD	Fan-Off Delay, Elec Heat	10-600	30	
→SG.CF	STAGED GAS CONFIGS			
→SG.CF→HT.ST	Staged Gas Heat Type	0 - 4	0	
→SG.CF→CAP.M	Max Cap Change per Cycle	5 - 45	45	
→SG.CF→M.R.DB	S.Gas DB min.dF/PID Rate	0 - 5	0.5	
→SG.CF→S.G.DB	St.Gas Temp. Dead Band	0 - 5 ^F	2	
→SG.CF→RISE	Heat Rise dF/sec Clamp	0.05 - 0.2	0.06	
→SG.CF→LAT.L	LAT Limit Config	0 - 20 ^F	10	
→SG.CF→LIM.M	Limit Switch Monitoring?	Yes/No	No	
→SG.CF→SW.H.T	Limit Switch High Temp	110 - 180 dF	170	
→SG.CF→SW.L.T	Limit Switch Low Temp	100 - 170 dF	160	
→SG.CF→HT.P	Heat Control Prop. Gain	0 - 1.5	1	
→SG.CF→HT.D	Heat Control Derv. Gain	0 - 1.5	1	
→SG.CF→HT.TM	Heat PID Rate Config	60 - 300 sec	90	
<b>SP</b>	SUPPLY STATIC PRESS.CFG.			
→SP.CF	Static Pressure Config	0 - 1 (multi-text strings)	No	
→CV.FD	Constant Vol IDF is VFD?	Yes/No	No	
→SP.FN	Static Pres.Fan Control?	Yes	Yes	
→SP.S	Static Pressure Sensor	Enable/Disable	Disable	
→SP.LO	Static Press. Low Range	-10 - 0	0	
→SP.HI	Static Press. High Range	0 - 10	5	
→SP.SP	Static Pressure Setpoint	0 - 5 "H2O	1.5	
→SP.MN	VFD Minimum Speed	0 - 100 %	20	
→SP.MX	VFD Maximum Speed	0 - 100 %	100	
→SP.FS	VFD Fire Speed Override	0 - 100 %	100	
→HT.VM	VFD Heating Min Speed	75 - 100 %	75	
→SP.RS	Stat. Pres. Reset Config	0 - 4 (multi-text strings)	0	
→SP.RT	SP Reset Ratio ("dF)	0 - 2.00 in. wg/dF	0.2	
→SP.LM	SP Reset Limit in iwc (")	0 - 2.00 in. wg	0.75	
→SP.EC	SP Reset Econo. Position	0 - 100 %	5	
→S.PID	STAT.PRESS.PID CONFIGS			
→S.PID→SP.TM	Stat.Pres.PID Run Rate	1 - 200 sec	2	
→S.PID→SP.P	Static Press. Prop. Gain	0 - 100	20	
→S.PID→SP.I	Static Pressure Intg. Gain	0 - 50	2	
→S.PID→SP.D	Static Pressure Derv. Gain	0 - 50	0	
→S.PID→SP.SG	Static Press.System Gain	0 - 50	1	
<b>ECON</b>	ECONOMIZER CONFIGURATION			
→EC.EN	Economizer Installed?	Yes/No	Yes	
→EC.MN	Economizer Min.Position	0 - 100 %	5	
→EC.MX	Economizer Max.Position	0 - 100 %	98	
→E.TRM	Economizr Trim For SumZ ?	Yes/No	Yes	
→E.SEL	Econ ChangeOver Select	0 - 3 (multi-text strings)	1	
→OA.E.C	OA Enthalpy ChgOvr Selct	1 - 5 (multi-text strings)	4	
→OA.EN	Outdr.Enth Compare Value	18 - 28	24	
→OAT.L	High OAT Lockout Temp	-40 - 120 dF	60	
→O.DEW	OA Dewpoint Temp Limit	50 - 62 dF	55	
→ORH.S	Outside Air RH Sensor	Enable/Disable	Disable	
→E.TYP	Economizer Control Type	1-3 (multi-text strings)	1	
→EC.SW	Economizer Switch Config	0 - 2 (multi-text strings)	0	
→E.CFG	ECON.OPERATION CONFIGS			
→E.CFG→E.P.GN	Economizer Prop.Gain	0.7 - 3.0	1	
→E.CFG→E.RNG	Economizer Range Adjust	0.5 - 5.0 ^F	2.5	
→E.CFG→E.SPD	Economizer Speed Adjust	0.1 - 10.0	0.75	
→E.CFG→E.DBD	Economizer Deadband	0.1 - 2.0 ^F	0.5	
→UEFC	UNOCC.ECON.FREE COOLING			
→UEFC→FC.CF	Unoc Econ Free Cool Cfg	0-2 (multi-text strings)	0	
→UEFC→FC.TM	Unoc Econ Free Cool Time	0 - 720 min	120	
→UEFC→FC.L.O	Un.Ec.Free Cool OAT Lock	40 - 70 dF	50	

CUT ALONG DOTTED LINE

CUT ALONG DOTTED LINE

ITEM	EXPANSION	RANGE	DEFAULT	ENTRY
<b>BP</b>	<b>BUILDING PRESS. CONFIG</b>			
→BP.CF	Building Press. Config	0-2	0	
→BP.RT	Bldg.Pres.PID Run Rate	5-120 sec	10	
→BP.P	Bldg. Press. Prop. Gain	0-5	0.5	
→BP.I	Bldg.Press.Integ.Gain	0-2	0.5	
→BP.D	Bldg.Press.Deriv.Gain	0-5	0.3	
→BP.SO	BP Setpoint Offset	0.0 - 0.5 "H2O	0.05	
→BP.MN	BP VFD Minimum Speed	0-100%	10	
→BP.MX	BP VFD Maximum Speed	0-100%	100	
→BP.FS	VFD/Act. Fire Speed/Pos.	0-100%	100	
→BP.MT	Power Exhaust Motors	1-2	1	
→BP.S	Building Pressure Sensor	Enable/Dsable	Dsable	
→BP.R	Bldg Press (+/-) Range	0 - 1.00 "H2O	0.25	
→BP.SP	Building Pressure Setp.	-0.25 → 0.25 "H2O	0.05	
→BP.P1	Power Exhaust On Setp.1	0 - 100 %	35	
→BP.P2	Power Exhaust On Setp.2	0 - 100 %	75	
→B.CFG	<b>BP ALGORITHM CONFIGS</b>			
→B.CFG→BP.SL	Modulating PE Alg. Slct.	1-3	1	
→B.CFG→BP.TM	BP PID Evaluation Time	0 - 10 min	1	
→B.CFG→BP.ZG	BP Threshold Adjustment	0.1 - 10.0 "H2O	1	
→B.CFG→BP.HP	High BP Level	0 - 1.000 "H2O	0.05	
→B.CFG→BP.LP	Low BP Level	0 - 1.000 "H2O	0.04	
<b>D.LV.T</b>	<b>COOL/HEAT SETPT. OFFSETS</b>			
→L.H.ON	Dmd Level Lo Heat On	-1 - 2 ^F	1.5	
→H.H.ON	Dmd Level(+) Hi Heat On	0.5 - 20.0 ^F	0.5	
→L.H.OF	Dmd Level(-) Lo Heat Off	0.5 - 2 ^F	1	
→L.C.ON	Dmd Level Lo Cool On	-1 - 2 ^F	1.5	
→H.C.ON	Dmd Level(+) Hi Cool On	0.5 - 20.0 ^F	0.5	
→L.C.OF	Dmd Level(-) Lo Cool Off	0.5 - 2 ^F	1	
→C.T.LV	Cool Trend Demand Level	0.1 - 5 ^F	0.1	
→H.T.LV	Heat Trend Demand Level	0.1 - 5 ^F	0.1	
→C.T.TM	Cool Trend Time	30 - 600 sec	120	
→H.T.TM	Heat Trend Time	30 - 600 sec	120	
<b>DMD.L</b>	<b>DEMAND LIMIT CONFIG.</b>			
→DM.L.S	Demand Limit Select	0 - 3 (multi-text strings)	0	
→D.L.20	Demand Limit at 20 ma	0 - 100 %	100	
→SH.NM	Loadshed Group Number	0 - 99	0	
→SH.DL	Loadshed Demand Delta	0 - 60 %	0	
→SH.TM	Maximum Loadshed Time	0 - 120 min	60	
→D.L.S1	Demand Limit Sw.1 Setpt.	0 - 100 %	80	
→D.L.S2	Demand Limit Sw.2 Setpt.	0 - 100 %	50	
<b>IAQ</b>	<b>INDOOR AIR QUALITY CFG.</b>			
→DCV.C	<b>DCV ECONOMIZER SETPOINTS</b>			
→DCV.C→EC.MN	Economizer Min.Position	0 - 100 %	5	
→DCV.C→IAQ.M	IAQ Demand Vent Min.Pos.	0 - 100 %	0	
→AQ.CF	<b>AIR QUALITY CONFIGS</b>			
→AQ.CF→IQ.A.C	IAQ Analog Sensor Config	0 - 4 (multi-text strings)	0	
→AQ.CF→IQ.A.F	IAQ 4-20 ma Fan Config	0 - 2 (multi-text strings)	0	
→AQ.CF→IQ.I.C	IAQ Discrete Input Config	0 - 2 (multi-text strings)	0	
→AQ.CF→IQ.I.F	IAQ Disc.In. Fan Config	0 - 2 (multi-text strings)	0	
→AQ.CF→OQ.A.C	OAQ 4-20ma Sensor Config	0 - 2 (multi-text strings)	0	
→AQ.SP	<b>AIR QUALITY SETPOINTS</b>			
→AQ.SP→IQ.O.P	IAQ Econ Override Pos.	0 - 100 %	100	
→AQ.SP→DAQ.L	Diff.Air Quality LoLimit	0 - 1000	100	
→AQ.SP→DAQ.H	Diff.Air Quality HiLimit	100 - 2000	700	
→AQ.SP→D.F.OF	DAQ PPM Fan Off Setpoint	0 - 2000	200	
→AQ.SP→D.F.ON	DAQ PPM Fan On Setpoint	0 - 2000	400	
→AQ.SP→IAQ.R	Diff. AQ Responsiveness	-5 - 5	0	
→AQ.SP→OAQ.L	OAQ Lockout Value	0 - 2000	0	
→AQ.SP→OAQ.U	User Determined OAQ	0 - 5000	400	
→AQ.S.R	<b>AIR QUALITY SENSOR RANGE</b>			

ITEM	EXPANSION	RANGE	DEFAULT	ENTRY
→AQ.S.R→IQ.R.L	IAQ Low Reference	0 - 5000	0	
→AQ.S.R→IQ.R.H	IAQ High Reference	0 - 5000	2000	
→AQ.S.R→OQ.R.L	OAQ Low Reference	0 - 5000	0	
→AQ.S.R→OQ.R.H	OAQ High Reference	0 - 5000	2000	
→IAQ.P	IAQ PRE-OCCUPIED PURGE			
→IAQ.P→IQ.PG	IAQ Purge	Yes/No	No	
→IAQ.P→IQ.P.T	IAQ Purge Duration	5-60 min	15	
→IAQ.P→IQ.P.L	IAQ Purge LoTemp Min Pos	0-100 %	10	
→IAQ.P→IQ.P.H	IAQ Purge HiTemp Min Pos	0-100 %	35	
→IAQ.P→IQ.L.O	IAQ Purge OAT Lockout	35-70 dF	50	
<b>DEHU</b>	<b>DEHUMIDIFICATION CONFIG.</b>			
→D.SEL	Dehumidification Config	0-2(multi-text strings)	0	
→D.SEN	Dehumidification Sensor	1-2(multi-text strings)	1	
→D.EC.D	Econ disable in DH mode?	Yes/No	Yes	
→D.V.CF	Vent Reheat Setpt Select	0-1(multi-text strings)	0	
→D.V.RA	Vent Reheat RAT offset	0-8 ^F	0	
→D.V.HT	Vent Reheat Setpoint	55-95 dF	70	
→D.C.SP	Dehumidify Cool Setpoint	40-55 dF	45	
→D.RH.S	Dehumidify RH Setpoint	10-90 %	55	
<b>CCN</b>	<b>CCN CONFIGURATION</b>			
→CCNA	CCN Address	1 - 239	1	
→CCNB	CCN Bus Number	0 - 239	0	
→BAUD	CCN Baud Rate	1 - 5 (multi-text strings)	3	
→BROD	<b>CCN BROADCAST DEFINITIONS</b>			
→BROD→TM.DT	CCN Time/Date Broadcast	ON/OFF	On	
→BROD→OAT.B	CCN OAT Broadcast	ON/OFF	Off	
→BROD→ORH.B	CCN OARH Broadcast	ON/OFF	Off	
→BROD→OAQ.B	CCN OAQ Broadcast	ON/OFF	Off	
→BROD→G.S.B	Global Schedule Broadcast	ON/OFF	Off	
→BROD→B.ACK	CCN Broadcast Ack'er	ON/OFF	Off	
→SC.OV	<b>CCN SCHEDULES-OVERRIDES</b>			
→SC.OV→SCH.N	Schedule Number	0 - 99	1	
→SC.OV→HOL.T	Accept Global Holidays?	YES/NO	No	
→SC.OV→O.T.L.	Override Time Limit	0 - 4 HRS	1	
→SC.OV→OV.EX	Timed Override Hours	0 - 4 HRS	0	
→SC.OV→SPT.O	SPT Override Enabled ?	YES/NO	Yes	
→SC.OV→T58.O	T58 Override Enabled ?	YES/NO	Yes	
→SC.OV→GL.OV	Global Sched. Override ?	YES/NO	No	
<b>ALLM</b>	<b>ALERT LIMIT CONFIG.</b>			
→SPL.O	SPT lo alert limit/occ	-10-245 dF	60	
→SP.H.O	SPT hi alert limit/occ	-10-245 dF	85	
→SPL.U	SPT lo alert limit/unocc	-10-245 dF	45	
→SP.H.U	SPT hi alert limit/unocc	-10-245 dF	100	
→SA.L.O	EDT lo alert limit/occ	-40-245 dF	40	
→SA.H.O	EDT hi alert limit/occ	-40-245 dF	100	
→SA.L.U	EDT lo alert limit/unocc	-40-245 dF	40	
→SA.H.U	EDT hi alert limit/unocc	-40-245 dF	100	
→RA.L.O	RAT lo alert limit/occ	-40-245 dF	60	
→RA.H.O	RAT hi alert limit/occ	-40-245 dF	90	
→RA.L.U	RAT lo alert limit/unocc	-40-245 dF	40	
→RA.H.U	RAT hi alert limit/unocc	-40-245 dF	100	
→R.RH.L	RARH low alert limit	0-100 %	0	
→R.RH.H	RARH high alert limit	0-100 %	100	
→SPL	SP low alert limit	0-5 "H2O	0	
→SP.H	SP high alert limit	0-5 "H2O	2	
→BP.L	BP lo alert limit	-0.25-0.25 "H2O	-0.25	
→BP.H	BP high alert limit	-0.25-0.25 "H2O	0.25	
→IAQ.H	IAQ high alert limit	0-5000	1200	
<b>TRIM</b>	<b>SENSOR TRIM CONFIG.</b>			
→SAT.T	Air Temp Lvg SF Trim	-10 - 10 ^F	0	
→RAT.T	RAT Trim	-10 - 10 ^F	0	
→OAT.T	OAT Trim	-10 - 10 ^F	0	
→SPT.T	SPT Trim	-10 - 10 ^F	0	
→CTA.T	Cir A Sat.Cond.Temp Trim	-30 - 30 ^F	0	
→CTB.T	Cir B Sat.Cond.Temp Trim	-30 - 30 ^F	0	
→SPA.T	Suct.Press.Circ.A Trim	-50 - 50 PSIG	0	
→SPB.T	Suct.Press.Circ.B Trim	-50 - 50 PSIG	0	
→DPA.T	Dis.Press.Circ.A Trim	-50 - 50 PSIG	0	
→DPB.T	Dis.Press.Circ.B Trim	-50 - 50 PSIG	0	

CUT ALONG DOTTED LINE

CUT ALONG DOTTED LINE



ITEM	EXPANSION	RANGE	DEFAULT	ENTRY
<b>SW.LG</b>	SWITCH LOGIC: NO / NC			
→ <b>FTS.L</b>	Filter Status Inpt-Clean	Open/Close	Open	
→ <b>IGC.L</b>	IGC Feedback - Off	Open/Close	Open	
→ <b>RMI.L</b>	RemSw Off-Unoc-Strt-NoOv	Open/Close	Open	
→ <b>ECS.L</b>	Economizer Switch - No	Open/Close	Open	
→ <b>SFS.L</b>	Fan Status Sw. - Off	Open/Close	Open	
→ <b>DL1.L</b>	Dmd.Lmt.Sw.1 - Off	Open/Close	Open	
→ <b>DL2.L</b>	Dmd.Lmt.-Dehumid - Off	Open/Close	Open	
→ <b>IAQ.L</b>	IAQ Disc.Input - Low	Open/Close	Open	
→ <b>FSD.L</b>	Fire Shutdown - Off	Open/Close	Open	
→ <b>PRS.L</b>	Pressurization Sw. - Off	Open/Close	Open	
→ <b>EVC.L</b>	Evacuation Sw. - Off	Open/Close	Open	
→ <b>PRG.L</b>	Smoke Purge Sw. - Off	Open/Close	Open	
<b>DISP</b>	DISPLAY CONFIGURATION			
→ <b>TEST</b>	Test Display LEDs	ON/OFF	Off	
→ <b>METR</b>	Metric Display	ON/OFF	Off	
→ <b>LANG</b>	Language Selection	0-1 (multi-text strings)	0	
→ <b>PAS.E</b>	Password Enable	ENABLE/DISABLE	Enable	
→ <b>PASS</b>	Service Password	0000-9999	1111	

