

[54] **CIRCUIT BREAKER WITH OVERCURRENT AND AUXILIARY RELEASES**

[75] Inventor: **John De Torre**, Albemarle, N.C.
 [73] Assignee: **Federal Pacific Electric Company**, Newark, N.J.
 [22] Filed: **Sept. 15, 1972**
 [21] Appl. No.: **289,763**

[52] **U.S. Cl.**..... **335/18, 335/43**
 [51] **Int. Cl.**..... **H01h 73/48**
 [58] **Field of Search** 335/18, 9, 10, 35,
 335/174, 43, 175, 16, 20; 337/53; 318/18 D;
 200/50 C

[56] **References Cited**
UNITED STATES PATENTS

3,663,903	5/1972	Kussy et al.....	335/16
3,161,747	12/1964	Cole.....	337/53
2,779,831	1/1957	Thomas.....	200/50 C
2,860,207	11/1958	Rigert.....	335/175

Primary Examiner—Harold Broome
Attorney—Paul S. Martin

[57] **ABSTRACT**

An automatic circuit breaker here includes a mechanism for manual opening and closing of the contacts, and an overcurrent release. Auxiliary release means is also included for opening of the contacts, as in response to a detected ground fault. The overcurrent release includes a latch that is caused to deflect laterally in response to an overcurrent, and the mechanism includes a shiftable latch part having a lateral surface that engages an abutment part of the overcurrent latch. Deflection of the latch, or retraction of the latch part effects release of the circuit breaker. An electromagnet has an armature for operating the shiftable latch part. The armature is located close to the shiftable latch part in the closed configuration of the mechanism, but there is no possible interference by the armature with any of the operating paths of the circuit breaker mechanism.

6 Claims, 4 Drawing Figures

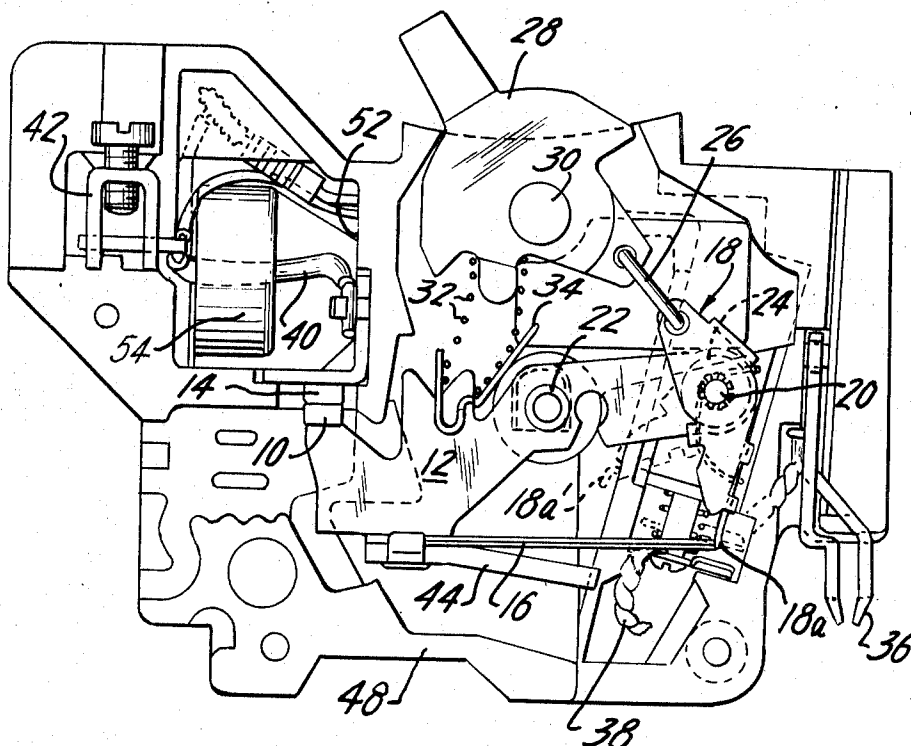

FIG. 1

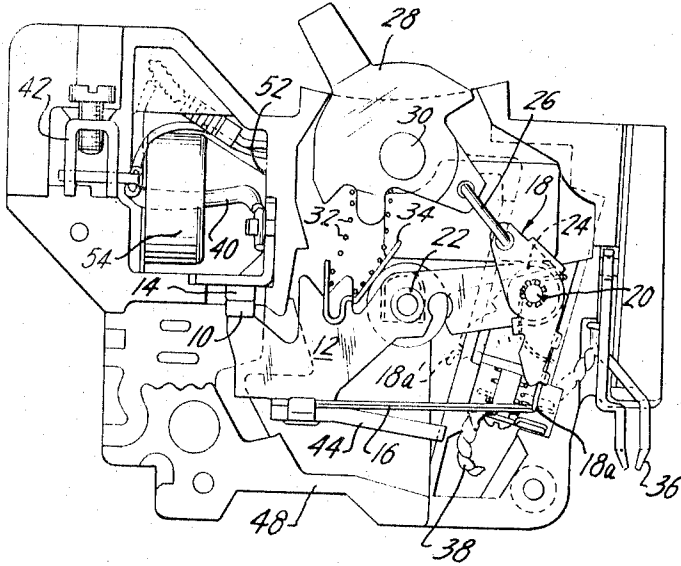

FIG. 2

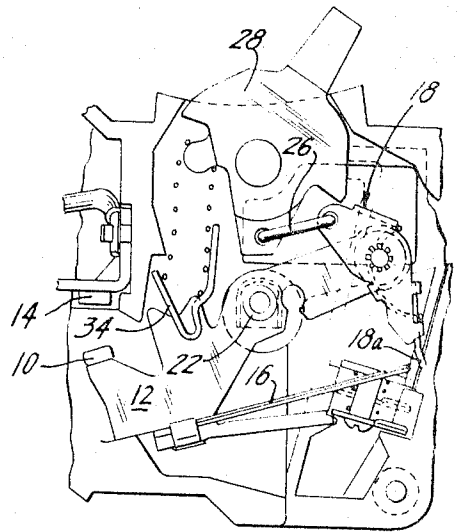

FIG. 3

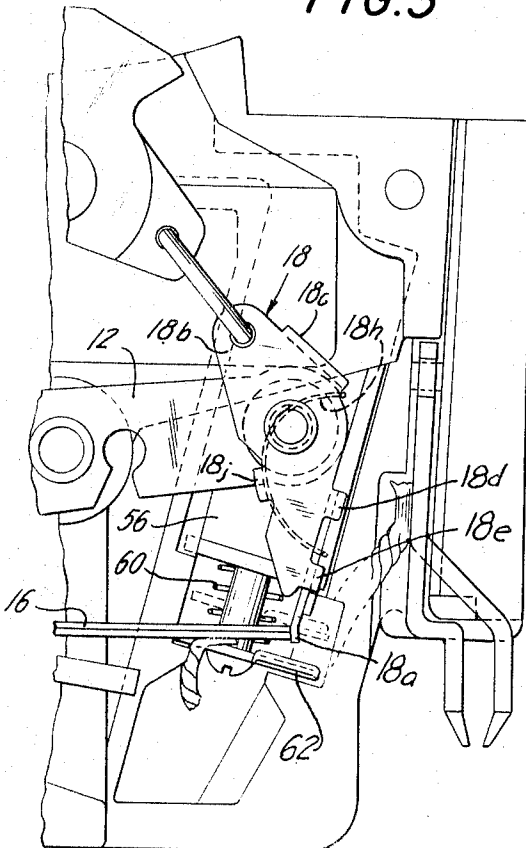
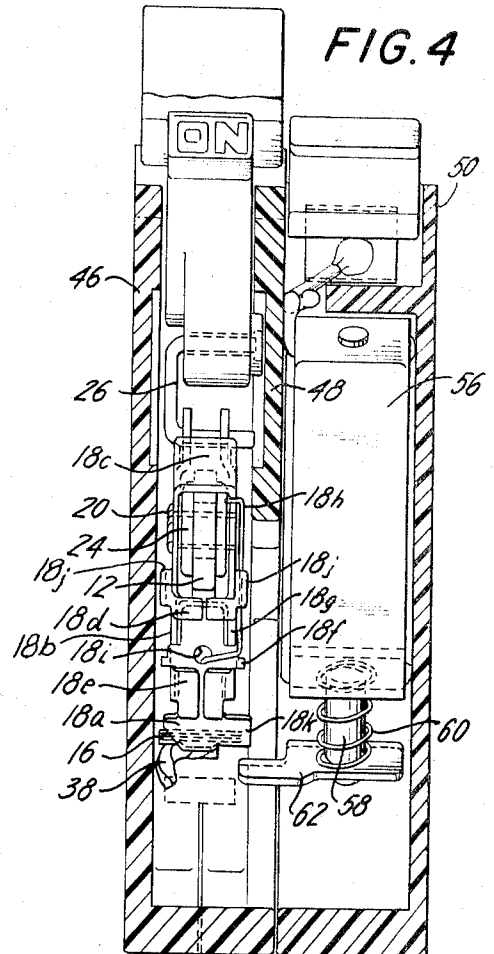

FIG. 4



CIRCUIT BREAKER WITH OVERCURRENT AND AUXILIARY RELEASES

This invention relates to circuit breakers, especially to manually operable circuit breakers.

The embodiment of this invention described in detail below and shown in the drawings includes a known circuit breaker mechanism of the type in U.S. Pat. No. 2,811,605, issued Oct. 29, 1957 to P. M. Christensen et al., in which a single pair of contacts is manually operable to close and open the contacts to interrupt a branch circuit. The circuit breaker incorporates an overcurrent release for causing automatic opening of the contacts in case of a sudden severe overcurrent occasioned by a short-circuit of the protected circuit.

In general it is common for manually operable single-pole circuit breakers to include release devices additional to their overcurrent release. Thus, in the case of a multi-pole circuit breaker, one pole that is released by an overcurrent can act mechanically to effect release of companion mechanisms of other poles to release those other poles. Also, it is sometimes necessary to provide for remote-control release of a circuit breaker, by including a so-called shunt-trip electromagnet in the circuit breaker. Under-voltage tripping mechanism is also used in this way, having an electromagnet that is normally energized to prevent a spring from operating a circuit breaker tripping device so long as there is sufficient voltage in the protected circuit but to release spring-operated tripping device in case of failure or decrease of the available voltage. Further, ground-fault tripping of a circuit breaker is often accomplished by a shunt-trip electromagnet controlled by a ground-fault sensing device that provides operating current for the electromagnet in case of ground leakage current above a rated level such as 5.0 milliamperes. Each of these devices other than or additional to the overcurrent release means may be called an auxiliary release.

The present invention provides a novel means for enabling an auxiliary tripping device to release to trip or release a circuit breaker. The novel circuit breaker (in common with known circuit breakers) has a latched device having a lateral surface abutted by a shoulder or an abutment end of an overcurrent responsive latch, this latch being deflected out of the path of the latched device upon occurrence of an overcurrent. In the novel circuit breaker, the latched device includes a latched part that is shifted out of its obstructed position by auxiliary tripping means, in particular by an electromagnet.

The invention represents a distinctive solution to the problem of providing auxiliary tripping means for the type of mechanism in the above-mentioned U.S. Pat. No. 2,811,605. In that patent there is a manually operable linkage including a handle coupled to a pivoted unit having three principal components that are latched during the closing operation of the movable contact, where the latched unit includes a pivoted arm carrying a movable contact, a so-called actuator pivoted to a moving part of the contact arm and an overcurrent release latch carried by the contact arm and normally forming an abutment for a latched part of the actuator. The components of the three-part unit in that type of circuit breaker travel through space that might otherwise be available for auxiliary tripping means. Moreover the actuator, upon release, must be free to move

through its release path, which further reduces the space available for an auxiliary release device. The invention provides the actuator with a shiftable part that moves with the actuator and as a fixed part of the actuator, in all the ways needed incidental to the ordinary operation of the circuit breaker mechanism, and an auxiliary tripping device is disposed a short distance beyond the end-point in the path of movement traveled by a portion of the said shiftable part as the latched unit is moved for closing the contacts. The auxiliary tripping device then can shift the shiftable part in the reverse direction to release the three-part latched unit, and only a short stroke and very little effort are needed to do so. In the case of a shunt-tripper or a ground-fault tripper, an efficient and compact electromagnet is effective for this job. The following detailed description of the illustrative embodiment of the invention represents the presently preferred manner of applying the invention, which is regarded exemplary for the purpose of the invention but which is naturally susceptible of modification and varied applications by those skilled in this art. The illustrative embodiment is shown in the accompanying drawings.

In the drawings:

FIG. 1 is a side view of an illustrative embodiment of the invention, being a circuit breaker in its closed configuration with the front cover removed to show the internal parts;

FIG. 2 is a fragmentary view like that of FIG. 1 with parts shown in their "open" configuration;

FIG. 3 is a fragmentary view of FIG. 1, drawn to greatly enlarged scale; and

FIG. 4 is a right-hand elevation of the circuit breaker of FIG. 3, to the same scale, portions of the casing being broken away and shown in cross-section to reveal internal components.

The circuit breaker mechanism shown in the drawing is, to a large extent, the same as that in U.S. Pat. No. 2,811,605. That mechanism includes a moving contact 10 carried by pivoted electrically conductive contact arm 12 as of copper, and operable into engagement with companion or stationary contact 14 when the circuit breaker is closed. A bimetal 16 is united to contact arm 12 at the left in FIG. 1, and bimetal 16 is arranged so that its right-hand extremity deflects downward when the bimetal is heated. A so-called actuator 18 has a pivot 20 on contact arm 12 which, in turn, has a pivot 22 approximately midway between contact 10 and pivot 20. An insulating bushing 24 (note FIG. 4) insulates actuator 18 from contact arm 12. A U-shaped wire link 26 couples actuator 18 to handle 28 which is operable about its pivot 30 in bearings in the enclosure. A push-off spring 32 acts between handle 28 and contact arm 12 to bias the contact arm counterclockwise about pivot 22, thus biasing the contact arm in the opening direction. Spring 32 also biases handle 28 in the opening direction when the circuit breaker is open (FIG. 2).

In operating the circuit breaker from the open position as shown in FIG. 2 to the closed position of FIG. 1, handle 28 is operated counterclockwise, driving link 26 bodily to the right. This initially causes actuator 18 to move clockwise so that the lateral face of latch part 18a of the actuator presses against the end of bimetal 16. After that occurs, further operation of the handle causes counterclockwise motion of a latched unit consisting of actuator 18, bimetal 16, and contact arm 12

about pivot 22. During the closing motion, so-called "snap-lever" 34 engages a shoulder on the enclosure and momentarily arrests part of contact arm 12 to the left of pivot 22. Continued operation of handle 28 in the closing direction continues to drive link 26 and actuator 18 in the closing motion of the mechanism. Pivot 22 is a coil spring whose axis is perpendicular to plane of the sheet. The ends of the spring are supported in opposite cavities in opposite walls of the enclosure. When snap-lever 34 is arrested and arrests part of contact arm 12, further contact-closing operation of handle 28 causes the middle of spring 22 to deflect downward, and to be stressed. After certain point, the snap-lever 34 is disengaged from the abutment in the enclosure (as described more fully in the above-mentioned patent) and contact 10 is freed to snap closed abruptly. In the closed condition of the mechanism, handle 18 and link 26 constitute an over-set toggle that holds the handle in its "ON" position and develops a reaction force acting on actuator 18 along a line that is slightly to the right of the axis of pivot 20 as viewed in FIG. 1. This produces a clockwise bias on actuator 18, causing latch part 18a to press against bimetal 16.

With the contacts closed, a current path can be traced through the circuit breaker starting with a plug-in line terminal 36, along highly flexible conductive braid 38 to a weld at a point near the latched end of bimetal 16, along bimetal 16 and through part of contact arm 12, through engaged contacts 10 and 14, and then through a bracket and a conductor 40 to a load terminal 42.

Handle 28 can be operated clockwise, allowing spring 32 to drive contact arm 12 back to the position of FIG. 2.

Under normal conditions, the current through the circuit breaker and through bimetal 16 in particular is insufficient to cause bimetal 16 to deflect significantly. In the event of a mild and persistent overcurrent, the abutment end of bimetal 16 deflects downward and out of the path of latch part 18a. When this occurs, the upward spring bias exerted by spring pivot 22 and the downward spring force of push-off spring 32 become effective to cause instantaneous clockwise pivoting of actuator 18 about pivot 20. Thereupon, push-off spring 32 drives contact arm 12 about pivot 22 into the position shown in FIG. 2, and the linkage returns automatically to the configuration in FIG. 2. In the event of a very high surge of current in bimetal 16, a soft magnetic pole 44 secured to arm 12 develops sufficient magnetic attraction for current-carrying bimetal 16 so that the bimetal is magnetically deflected downward to release the mechanism more suddenly than in the case of a slow and persistent overload.

The mechanism thus far described is entirely conventional and is described more fully (as stated above) in U.S. Pat. No. 2,811,605. It has been indicated that pivot 22 is a spring and participates in the operation of the mechanism. This is true, but other ways of achieving most of the functions of spring 22 are known in the art. For example, similar effects can be achieved by making pivot 22 in the form of a rigid pin and mounting contact 14 with a backup spring. As another alternative to making pivot 22 as a spring, link 26 can be formed as a lengthwise compressible member. The mechanism involving spring pivot 22 is described ore fully in U.S. Pat. No. 2,700,713 issued Jan. 25, 1955 to T. M. Cole et al.

The standard circuit breaker of this type thus includes an overcurrent release means 16, 44 carried by pivoted contact arm 12, the end of bimetal 16 constituting an abutment for engagement with latch part 18a. Various other forms of overcurrent release in this type of circuit breaker are known in the art and accordingly bimetal 16 and magnetic yoke 44 are purely illustrative.

An auxiliary release is provided pursuant to the present invention for causing the circuit breaker to open in response to an external control signal. By way of example, that external signal is one that is produced in response to detection of a ground fault in the load circuit protected by the circuit breaker in the drawing. As seen in FIG. 4, the illustrative circuit breaker includes a front casing wall 46 of molded insulation that provides partial support for the various components of the mechanism described above, in cooperation with another casing part 48. A third casing part 50 is united to casing parts 46 and 48 by suitable means such as rivets (not shown). Cavity 52 (FIG. 1) is formed in the various molded parts 46, 48 and 50 and contains a differential current transformer 54 whose function it is to sense ground fault current of the protected circuit. Another cavity (not shown) is formed between casing parts 48 and 50 for containing electronics which recognizes when transformer 54 produces an output signal representing the danger level, and that electronic circuit produces an output signal for causing auxiliary tripping of the circuit breaker, in a manner now to be described.

An electromagnet 56 including a pole structure and solenoid 56 is contained in a cavity formed by casing parts 48 and 50. Spring 60 biases armature 58 to its projected position, and the armature is attracted upward (as viewed in the drawings) when the electromagnet is energized. The differential current transformer 54 and the electronic circuit produces an energizing current for the solenoid 56 upon occurrence of a dangerous level of ground fault current. The following means is provided for enabling the electromagnet to effect automatic release of the circuit breaker even though the over-current sensing means 16, 44 is in its "normal" configuration.

Actuator 18 is formed in two parts, including a main or body part 18b through which pivot 20 extends and latch part 18a that is slidably carried by the body part. Body part 18b has side walls at opposite sides of contact arm 12 (FIG. 4) which side walls are unified by a bridge 18c. The two side walls of body part 18b of the actuator include guide portions 18d and 18e for confining lengthwise-slidable latch part 18a against movement away from body part 18d, and laterally extending ears 18f are slidable along edges 18g of side walls 18b. A spring 18h has a hooked end which enters a hole 18i in latch part 18a and the opposite end of spring 18h reacts against bridge 18c. Side walls 18b have symmetrical ears 18j. One of these ears is utilized to help in confining spring 18h and holding it in the required operating position.

There is a laterally extending projection 18k (FIG. 4) on the latch end of latch part 18a. Arm 62 carried by armature 58 is operable upward when electromagnet 56 is energized. When that occurs, latch part 18a is shifted upward, and actuator 18 becomes free to pivot clockwise as described previously in the case of an

overcurrent, thereby releasing the circuit breaker to open its contacts.

The circuit breaker mechanism of FIGS. 1 and 2 involves parts 12, 16 and 18 which move in various ways at different phases of the operation of the circuit breaker. Arm 62 is located in a position that is entirely clear of any possible interference with all such operating motions of the parts of the circuit breaker mechanism. There is no question of arm 62 interfering with the up-and-down motion of bimetal 16 and the right-hand portion of contact arm 12 when the circuit breaker mechanism is being operated by the handle to open and close the contacts. Further, arm 62 cannot interfere with the clockwise motion of actuator 18 when the circuit breaker has been released in response to an overcurrent as represented by the dotted-line positions of latch part 18a designated 18a'. When the circuit breaker is to be closed and the external lever portion of handle 28 is moved to the left, from its position in FIG. 2 to that in FIG. 1, latch part 18a initially engages the abutment end of bimetal 16 and thereafter the latched end of latch part 18a travels generally toward arm 62. At all times, there is ample clearance between latch part 18a and arm 62 so that the circuit breaker mechanism operates entirely normally. There is ample clearance space to allow for deflection of bimetal 16 either due to thermal deflection resulting from an overcurrent or due to magnetic attraction by yoke 48 in the event of a short-circuit. Despite its location clear of the operating paths of all the parts of the circuit breaker mechanism, arm 62 is relatively close to latch part 18a when the contacts are closed or in engagement for operating latch part 18a in the release direction. Consequently, only a short operating stroke of armature 58 is required.

I claim:

1. A circuit breaker including
 - i. a pair of contacts
 - ii. a movable arm operable to close and open said contacts,
 - iii. overcurrent release means carried by said arm, said overcurrent release means including an overcurrent latch that is caused to deflect from its normal position in response to an overcurrent,
 - iv. an actuator pivotally carried by said movable arm and having a body member and a latch part movable to retracted and projected positions relative to said body member and normally biased to said projected position for engagement of a lateral surface of said latch part by said latch when in said projected position for arresting said actuator against pivoting relative to said arm, said engagement being released both upon deflection of said latch due to an overcurrent and upon retraction of said latch part,
 - v. operating means articulated to said actuator for driving said actuator and said arm and said overcurrent release means through a contact-closing motion when the latch is engaged by said latch part, during which said latch part is transported in

an operating stroke, and
vi. auxiliary release means having a release member normally disposed out of said operating stroke of said latch part but operable into cooperation with said latch part upon completion of said contact-closing stroke for driving said latch part to said retracted position and thereby releasing said movable arm to open said contacts.

2. A circuit breaker in accordance with claim 1, wherein said auxiliary release means includes an electromagnet having a movable armature for operating said release member.

3. A circuit breaker in accordance with claim 1 wherein said auxiliary release means includes an electromagnet having a movable armature and wherein said release member is carried by said armature and operable thereby when the electromagnet is energized, said release member being arranged to operate in the direction opposite that traveled by said latch part during said contact closing motion of said actuator.

4. A circuit breaker having a pair of separable contacts and mechanism for operating said contacts including manual operating means for causing said contacts to open and close and control means adapted to hold the contacts closed subject to the contacts being opened by said manual operating means and to cause opening of said contacts both in response to an overcurrent and in response to auxiliary control, said control means including overcurrent responsive latching means having an abutment and a latched device including a shiftable part biased in a given direction into engagement with said abutment when holding said contacts closed, said abutment and said shiftable part having latching and latched positions, respectively, when holding the contacts closed, said overcurrent responsive latching means including means for deflecting said abutment transversely to said given direction and out of said latching position thereof for thereby disengaging said latched device and, in turn, for causing said operating mechanism to open the contacts, and auxiliary tripping means for causing said shiftable part to move transversely to said given direction and out of engagement with said abutment while the latter remains in said latching position for thereby effecting auxiliary release of the operating mechanism for opening the contacts while the abutment of said overcurrent latching means remains undeflected.

5. A circuit breaker in accordance with claim 4 wherein said auxiliary tripping means includes an electromagnet and means rendered operative by said electromagnet for causing said shiftable part to shift transversely to said given direction and out of engagement with said abutment and thereby to cause opening of the contacts.

6. A circuit breaker in accordance with claim 4 wherein said auxiliary tripping means includes an electromagnet and means including an armature for driving said shiftable part out of engagement with said abutment in response to energization of the electromagnet.

* * * * *