



# **GUIDELINES FOR RETAINING WALLS 4'-0" IN HEIGHT OR LESS**

Version 2014-11-11

Prepared by:  
Building Development Division  
Department of Development Services  
5 County Complex Ct.  
Suite 120  
Prince William, VA 22192  
703-792-6930

## Overview

This guideline provides the procedures for permitting, and inspections of Retaining Walls with the following conditions:

- Height of 4'-0" or less.
- No surcharge load from adjacent structures or driveways.
- No problem soils

If **any** of the above conditions are not met, please refer to the [Checklist for Retaining Wall Submissions and Inspections Requirements](#).

For Guardrail requirements, refer to [Policy 1.12 Retaining Wall Safety Devices](#).

## Definitions:

The following definitions are used in this handout:

- **Problem soils:** A problem soil is a soil type which may have a high water table, expansive clays, low bearing capacities, frost heave potential, or other behavioral problems. If your property contains a problem soil, you shall hire a geotechnical engineer to investigate the soil. In addition, the foundation system shall be professionally designed to take the soil's behavior into consideration.
- **Wall height:** Is the difference in grade level on either side of the wall at a specific location.
- **Retaining Wall:** A landscaping technique intended to change the contour or grading of the lot. Construction of any Retaining Wall with exposed height greater than 2'-0" (two feet) requires a permit. Retaining Walls with exposed heights of 24" (twenty-four inches) or greater **with surcharge or problem soil** shall be **engineered**.

## STEP 1: Zoning Permit Requirements:

In addition to the structural review performed by Building Plan Review, the Zoning Division will review your proposed Retaining Wall to ensure it will meet all required set backs regulated by that Division. Depending on the location of the Retaining Wall, you may be referred to the Watershed Management Branch, to ensure that the Retaining Wall's construction will not cause drainage problems to neighboring properties and or to your property. You must have your plans/plats approved by the Zoning Division before applying for a Building Permit.

The Zoning Division is located at 5 County Complex Court, Prince William, VA, 22192. Please contact the Zoning Division at 703-792-6830 for further information.

## STEP 2: Building Permit Application and Approval Requirements:

- Two copies of zoning approval with the location of the Retaining Wall highlighted.
- A copy of the Retaining Wall handout with the appropriate retaining wall type and height highlighted. Please refer to Appendix A, B or C for type and height of walls.
- Provide a fully filled [Building Permit Application Form](#) for each wall type.
- Provide wall elevations, showing exposed height.
- Pay any Fees Due (please see [www.pwcgov.org/BDDFeeSchedule](http://www.pwcgov.org/BDDFeeSchedule)).
- Obtain building permit or permits.

## STEP 3: Public Utility Requirements

Call **Miss Utility** at **811** or **1-800-552-7001** before excavating to ensure that the construction does not interfere with underground utility lines. “Miss Utility” is a free service to anyone who is planning to excavate. Utility companies support “Miss Utility” to prevent damage to their buried lines. The various companies will mark the path of underground utilities on the property. If you fail to contact Miss Utility and damage occurs, you will be liable for all repair costs.

## STEP 4: Inspection Steps and Procedures

To schedule an inspection of Retaining Walls:

Please see inspection checklist for Retaining Walls on page 4. To Schedule an inspection please go to [www.pwcgov.org/ePortal](http://www.pwcgov.org/ePortal) or call 1-866-457-5280. The numbers in parenthesis below are the numbers to be used for the automated system when scheduling that particular inspection.

**Please note:** any Retaining Wall built on problem soils is required to have the wall foundation inspected by an [approved licensed private geotechnical engineer](#).

**A COPY OF THE APPROVED PLAT AND PLANS SHALL BE AVAILABLE TO THE INSPECTOR DURING EACH INSPECTION OR NO INSPECTIONS WILL BE PERFORMED.**

## INSPECTION CHECKLIST FOR RETAINING WALLS

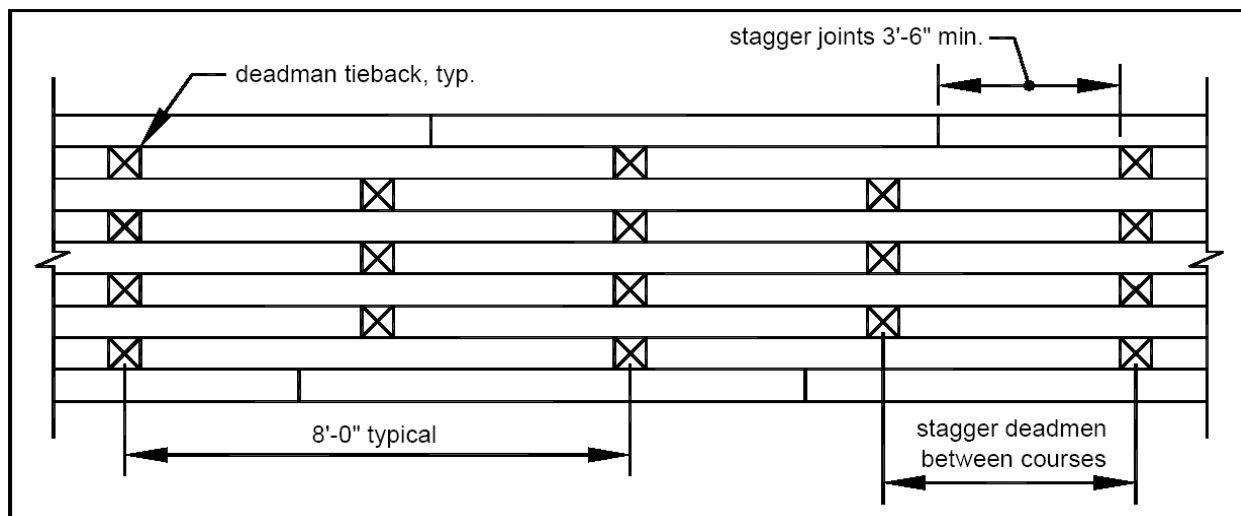
TYPE OF INSPECTION	INSPECTION PERFORMED BY	WORK TO BE COMPLETED PRIOR TO INSPECTION REQUEST	APPROVAL REQUIRED PRIOR TO PROCEEDING WITH
<b>TIMBER RETAINING WALLS</b>			
Retaining Wall	Residential Inspector	Timber Wall and dead-man placement. Back fill <b>(104)*</b>	
Final	Residential Inspector	Final Inspection. <b>(118)*</b>	
<b>REINFORCED MASONRY OR CONCRETE RETAINING WALLS</b>			
Retaining Wall (footing)	Residential Inspector or Geotechnical Engineer (in Problem Soils Area)	The area must be prepared for pouring concrete and the reinforcing steel must be placed. <b>(101)*</b>	Placing concrete in the footing forms.
Retaining Wall	Residential Inspector	Concrete blocks or forms and reinforcing steel must be in place. <b>(111)*</b>	Placing concrete in block cells or in forms.
Retaining Wall (waterproofing)	Residential Inspector	All parging and waterproofing must be completed and drain pipe installed and tied to the proper outfall. If the approved permit application indicates a problem soils area, backfill material and placement shall be certified by a geotechnical engineer. <b>(104)*</b>	Placing backfill.
Final	Residential Inspector	All backfilling, slope and construction of guardrail, if required. <b>(118)*</b>	

\* The numbers in parenthesis are inspection codes.

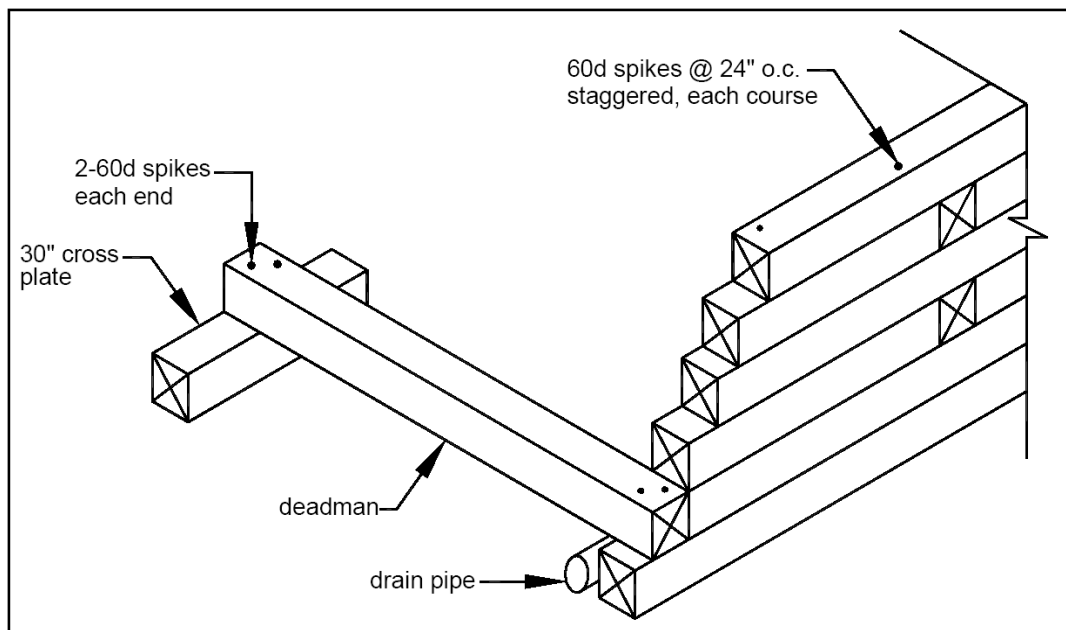
## TIMBER RETAINING WALLS

### GENERAL NOTES:

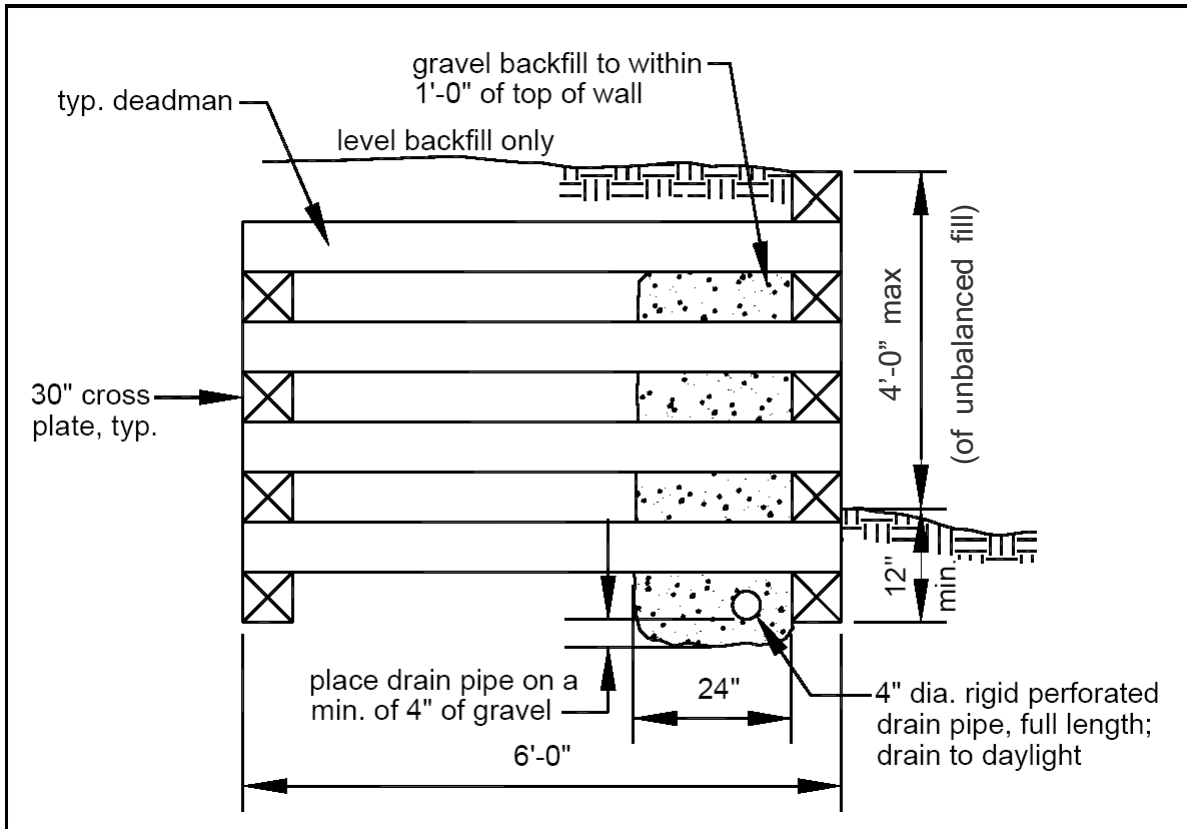
1. All lumber shall be 6x6, pressure treated in accordance with American Wood-Preservers' Association standards for ground contact, southern pine, grade #2 or better.
2. All spikes shall be 60d or equivalent, hot-dipped galvanized or stainless steel, and driven into predrilled holes. Spikes shall be of sufficient length to penetrate the base member a minimum of 2".
3. Member joints shall be staggered a minimum of 3'-6" from joints of the course above and below.
4. Each 6x6 member shall be secured at each end with 2-60d spikes driven vertically into the member below. Corners shall be secured with 2-60d spikes, driven horizontally as shown in FIGURE 4.



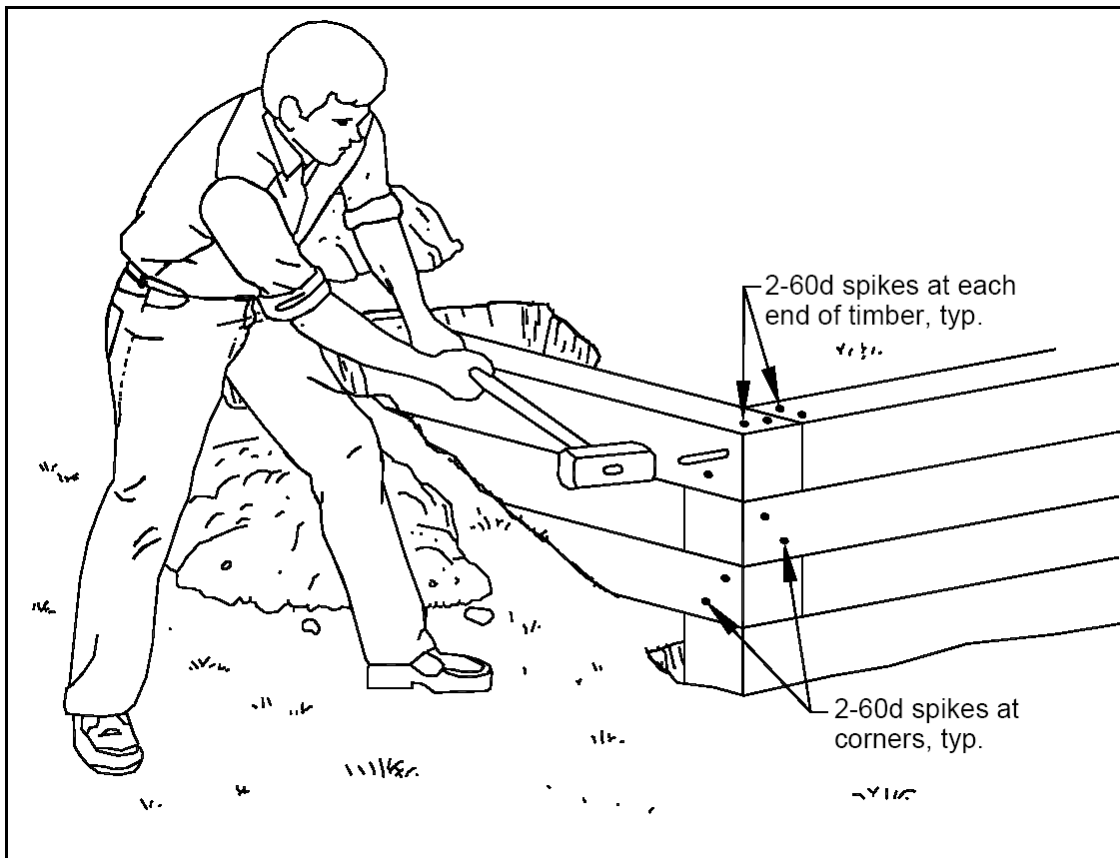
**FIGURE 1: TYPICAL ELEVATION**



**FIGURE 2: TYPICAL DEADMAN DETAIL**



**FIGURE 3: TYPICAL SECTION**

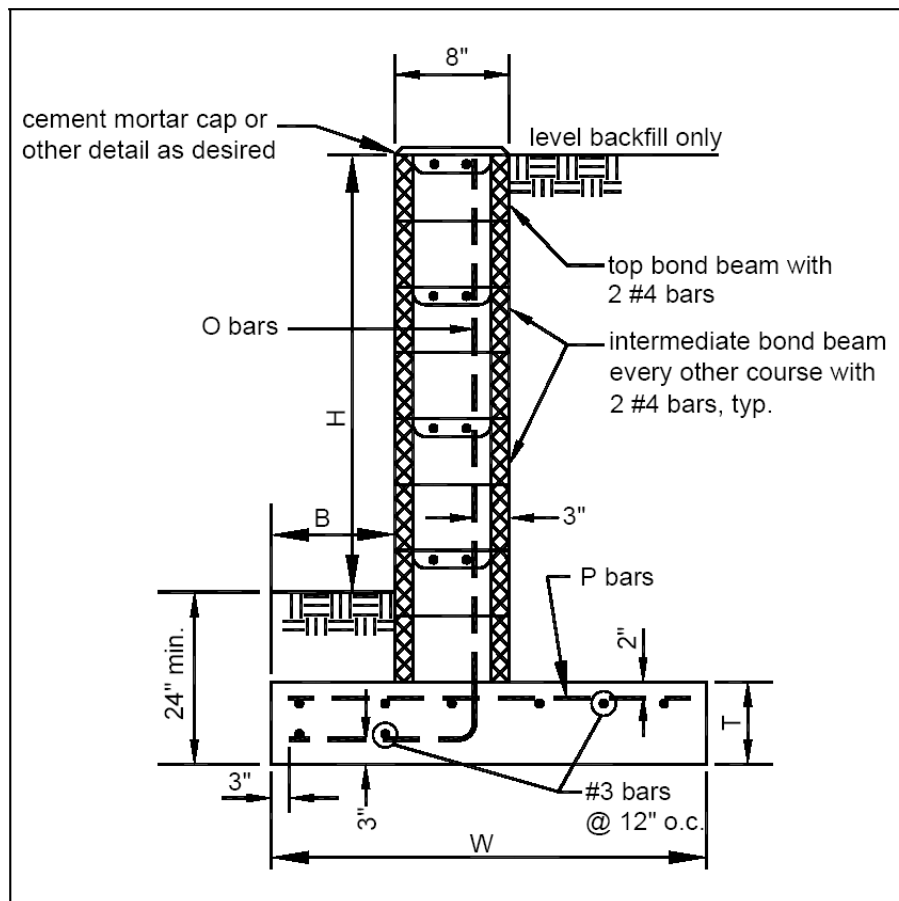


**FIGURE 4: TYPICAL CORNER DETAIL**

## REINFORCED CONCRETE MASONRY RETAINING WALLS

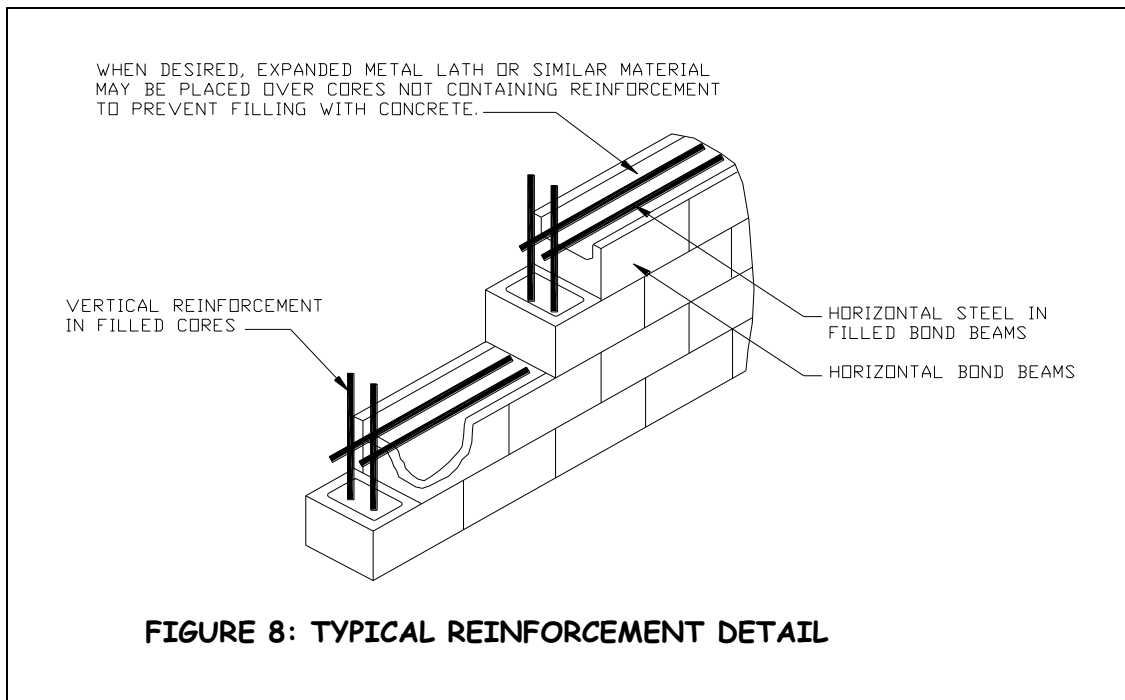
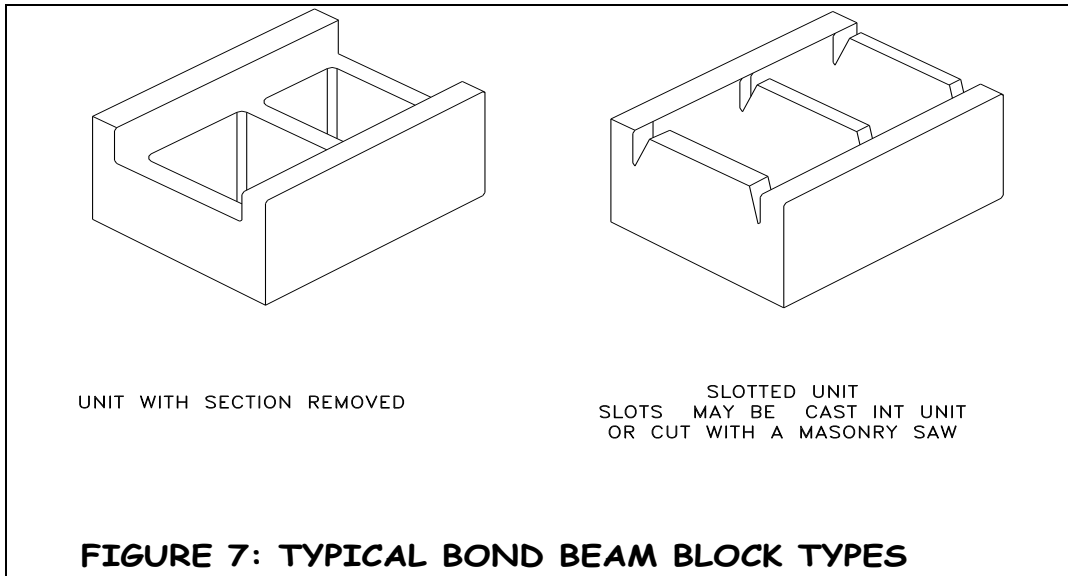
### GENERAL NOTES:

1. The minimum concrete compressive strength at 28 days shall be 3,000 PSI.
2. Materials used to produce concrete shall comply with the requirements of ACI 318.
3. Reinforcing steel shall comply with the requirements of ASTM A615 and shall have minimum yield strength of 60,000 PSI.
4. Concrete masonry blocks shall comply with the requirements of ASTM C90.
5. All joint reinforcement, ties and other accessories shall be resistant to corrosion.
6. All head and bed joints shall be 3/8" thick. Bed joints of the starting course over the concrete foundation may be between 1/4" and 3/4".
7. Mortar for masonry construction shall conform to the requirements of ASTM C270.
8. Backfilling against reinforced concrete masonry retaining walls shall not be permitted until at least 7 days after placing concrete or grout in respective cores.
9. Where heavy equipment is used in backfilling walls designed to resist earth pressure only, such equipment shall not approach closer to the top of the wall than a distance equal to the height of the wall. Care shall also be taken to avoid exerting large impact forces on the wall as caused by a large mass of moving earth.
10. Reference: National Concrete Masonry Association.

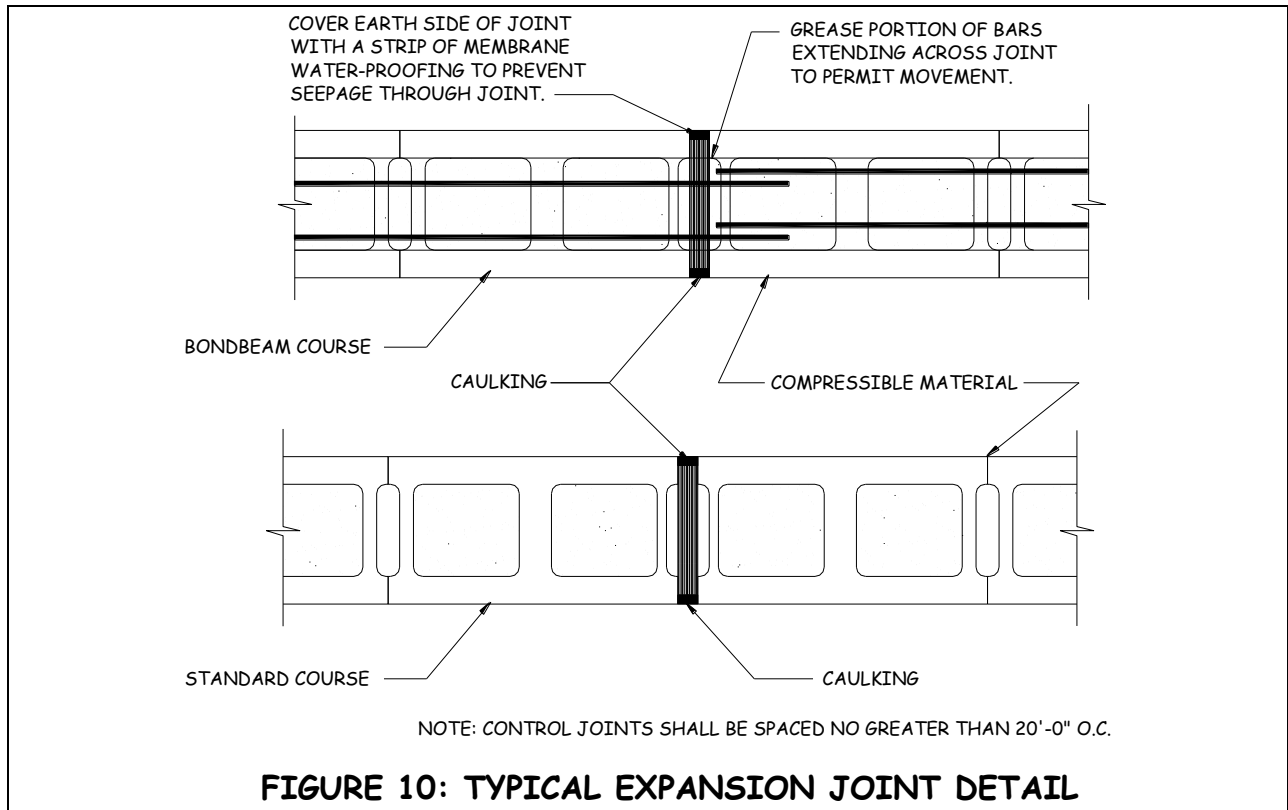
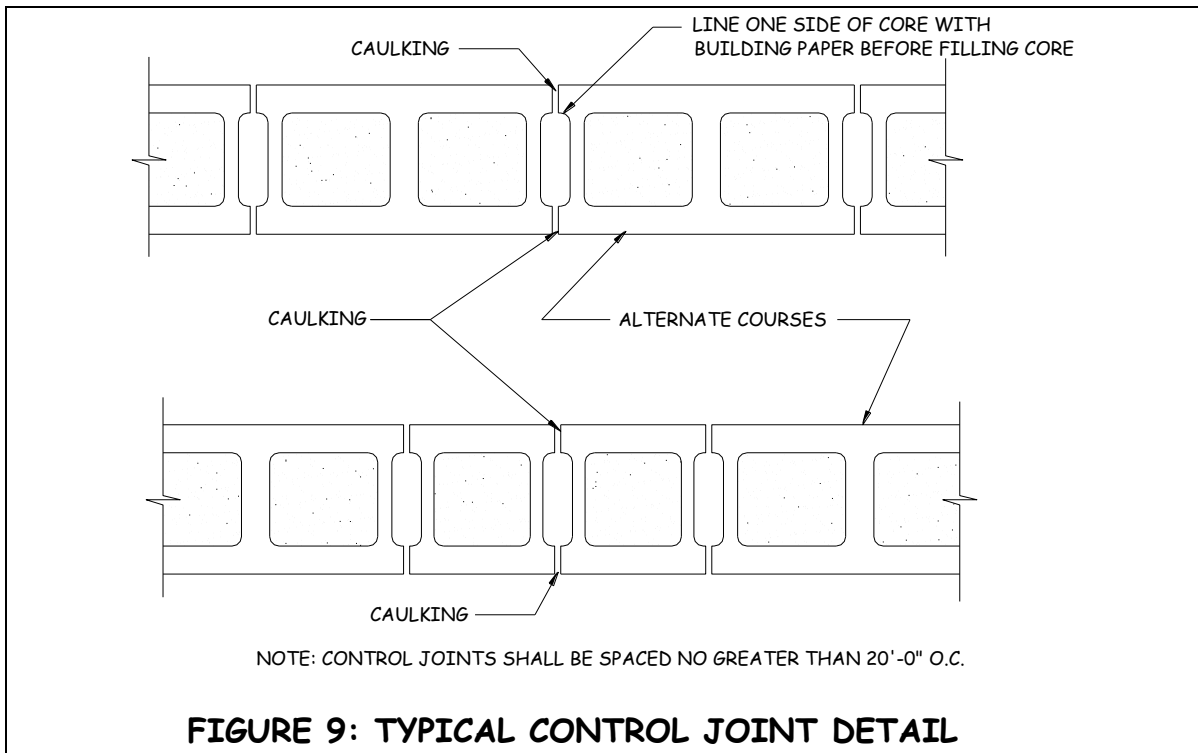


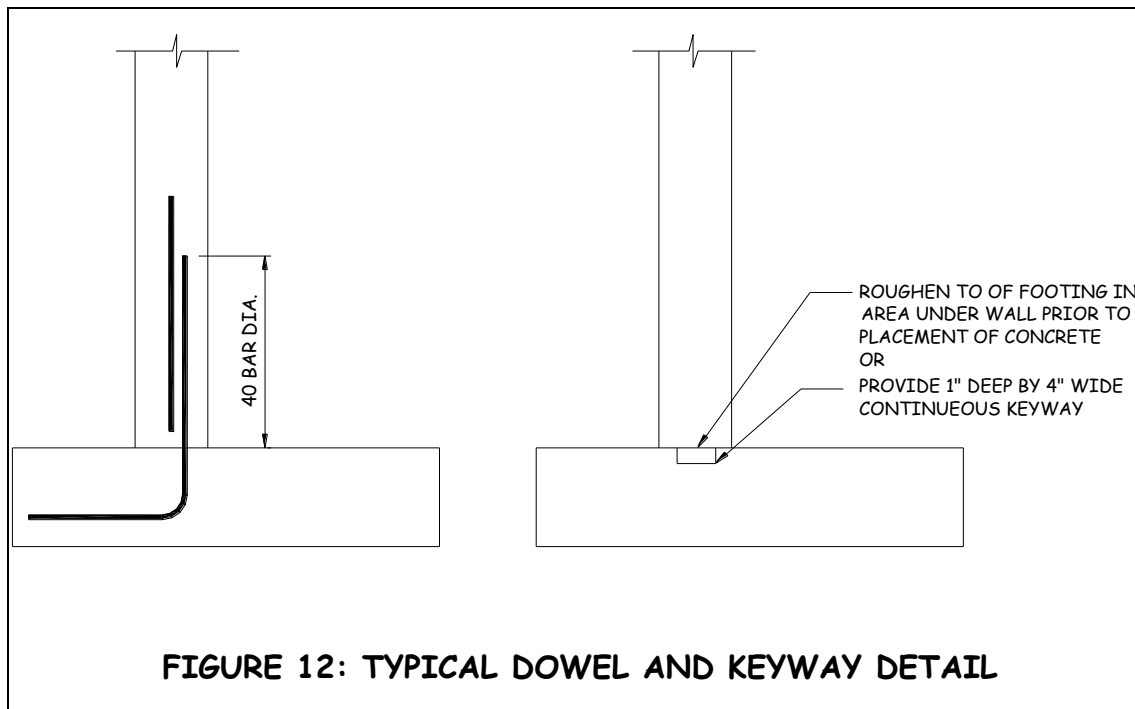
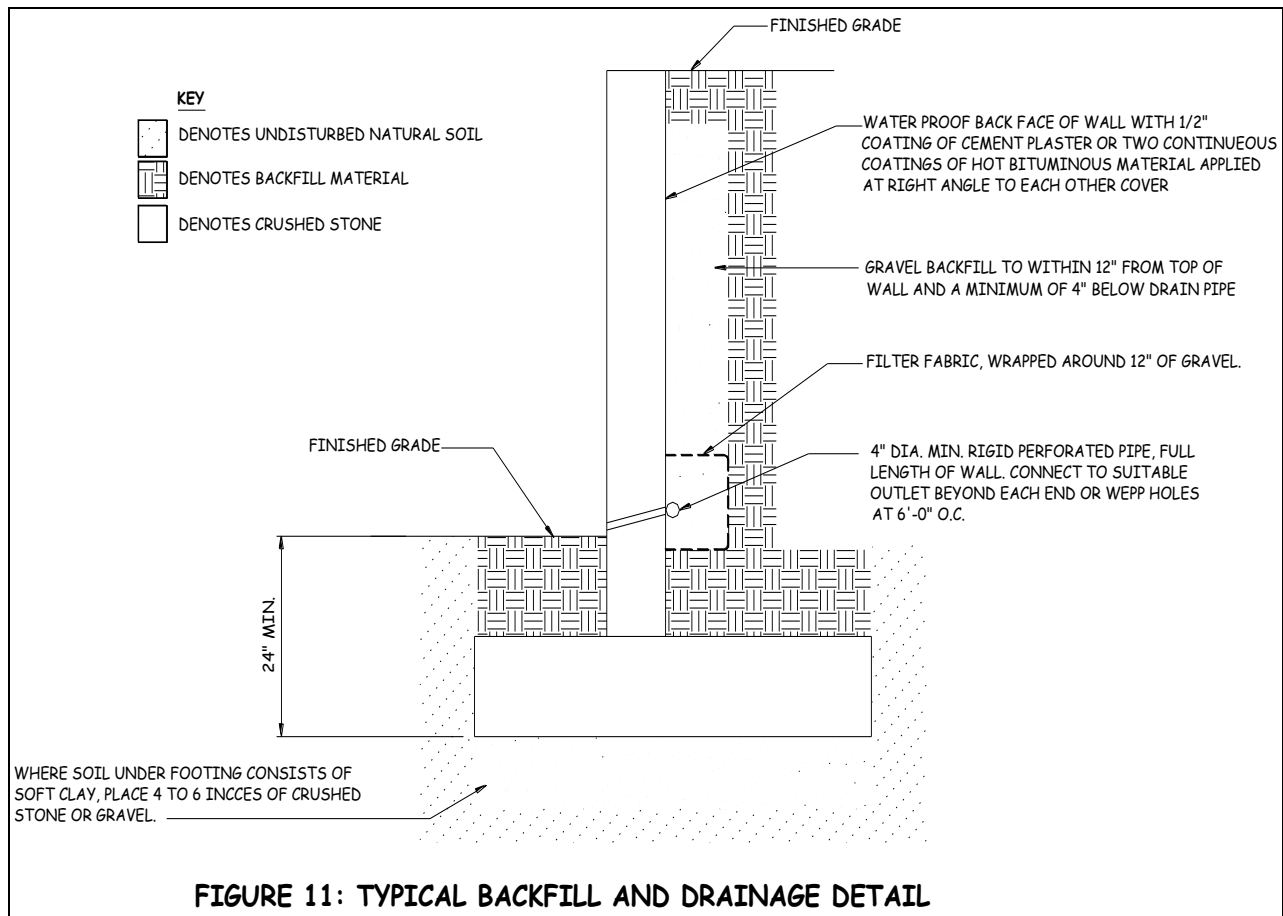
**TABLE 1: TYPICAL MASONRY WALL SPECIFICATIONS**

Dimensions				Reinforcing Bars	
H	B	W	T	O	P
2'-0"	12"	2'-8"	9"	#3@32"o.c.	#3@27"o.c.
2'-9"	12"	3'-0"	9"	#4@32"o.c.	#3@27"o.c.
3'-6"	12"	3'-3"	10"	#5@32"o.c.	#3@27"o.c.
4'-0"	14"	3'-8"	10"	#4@16"o.c.	#4@30"o.c.





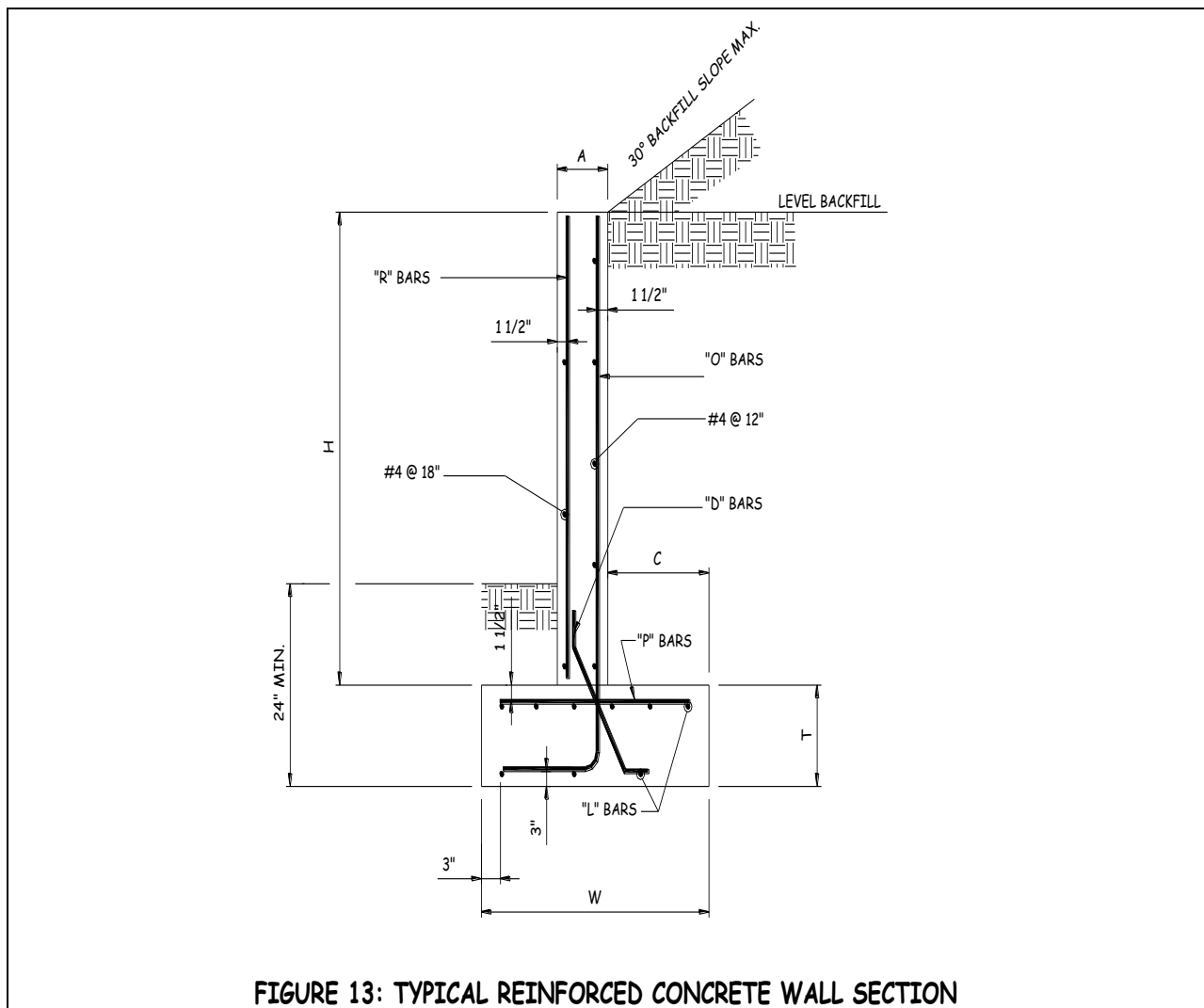




## REINFORCED CONCRETE RETAINING WALLS

### GENERAL NOTES:

1. The minimum concrete compressive strength at 28 days shall be 3,500 PSI.
2. Materials used to produce concrete shall comply with the requirements of ACI 318.
3. Reinforcing steel shall comply with the requirements of ASTM A615 and shall have minimum yield strength of 60,000 PSI.
4. Backfilling against reinforced concrete retaining walls shall not be permitted until the concrete has reached its 28 day strength.
5. Where heavy equipment is used in backfilling walls designed to resist earth pressure only, such equipment shall not approach closer to the top of the wall than a distance equal to the height of the wall. Care shall also be taken to avoid exerting large impact forces on the wall as caused by a large mass of moving earth.
6. Reference: Concrete Reinforcing Steel Institute.



**TABLE 2: TYPICAL CONCRETE WALL SPECIFICATIONS**

Dimensions					Reinforcing Bars				
H	A	C	W	T	R	O	D	P	L
Level Backfill									
2'-0"	8"	10"	2'-0"	12"	N.A.	#4@18"O.C.	N.A.	#4@18"O.C.	2#4
3'-0"	8"	1'-1"	2'-6"	12"	N.A.	#4@18"O.C.	N.A.	#4@18"O.C.	3#4
4'-0"	8"	1'-4"	3'-0"	12"	#4@18"O.C.	#4@18"O.C.	N.A.	#4@18"O.C.	4#4
Sloped Backfill									
2'-0"	8"	1'-1"	2'-6"	12"	N.A.	#4@18"O.C.	N.A.	#4@18"O.C.	2#4
3'-0"	8"	1'-4"	2'-9"	12"	N.A.	#4@18"O.C.	N.A.	#4@18"O.C.	3#4
4'-0"	8"	2'-4"	4'-0"	12"	#4@18"O.C.	#4@18"O.C.	N.A.	#4@18"O.C.	4#4

