

Tech Notes

NATIONAL PARK SERVICE
U.S. DEPARTMENT OF THE INTERIOR
WASHINGTON, D.C.

WINDOWS

NUMBER 2

Installing Insulating Glass in Existing Steel Windows

Charles E. Fisher

Preservation Assistance Division
National Park Service

CLICK ANYWHERE on THIS PAGE
to RETURN to WINDOW & DOOR
REPAIR & IMPROVEMENTS at
InspectApedia.com



MERGENTHALER LINOTYPE BUILDING

Chicago, Illinois

The Mergenthaler Linotype Building is a six-story printing loft building located in the South Loop Printing House National Register District in Chicago. The masonry building was constructed in 1883 and altered in 1917 with the addition of steel multipane hopper windows on the side and rear elevations. Recently renovated, the building now has residential condominiums in the upper stories and commercial space on the first floor.

The historic steel windows on the otherwise plain secondary elevations are a significant architectural feature,

clearly visible from the street. The 15 large 20-light windows on the side of the building measure 6' wide by 7' high with a center-pivoting hopper, while the 9 smaller 12-light windows are the same height but only 3' 9" wide. On the rear elevation, there are an additional 38 steel windows of 15 lights, measuring 3' by 7'. The individual lights are 14" by 20", a size common to pre-World War II steel sash.

During the renovation work on the building, the windows were repaired at the site and insulating glass was used in place of the existing single panes to

Many late 19th and early 20th century historic sash can be made more energy efficient through addition of insulating glass — an approach that should be considered before installing replacement sash.

improve the energy performance of the windows and the marketability of the condominium units.

Window Problems

The architect for the project, Kenneth Schroeder, AIA, with the Chicago firm of Kenneth Schroeder and Associates, was confronted with a series of problems in dealing with the steel windows. As is commonplace, lack of routine maintenance had led to rusting and mild corrosion of portions of the windows. Some of the sections, especially the hopper units, were bent, bowed or racked and a number of the 1/4" wire glass panes were broken.

In converting the building to residential use, ways of improving the thermal comfort of the occupants were explored and cost-effective means were studied for reducing energy consumption. Furthermore, a design had to be selected for additional windows that needed to be created in order to satisfy air and light requirements for the new use. Four

Figure 1. Insulating glass was installed without changing the appearance or operation of the steel window. Drawings: Martha L. Werenfels

possible approaches to the windows were examined:

- repair and repaint the existing windows;
- repair existing windows and install insulating glass;
- replace existing windows with custom-made, double-glazed steel sash; or
- remove existing units and install new aluminum double-hung thermal sash.

The following were specific considerations in assessing the four window alternatives:

1. Any window alteration would have to be compatible with the historic character and configuration of the existing steel windows.
2. Work on the windows beyond repair and repainting—including the possibility of all new replacement units—would have to be cost-effective in terms of increasing the marketability and value of the condominiums.
3. The existing wire glass would have to be replaced with clear glazing since the wire glass was considered inappropriate for the new residential use.
4. Any work on the windows would

have to be accomplished within a tight time schedule.

5. Addition of screening was desirable but not critical because the downtown area was not particularly insect-prone.

Of the four possible window treatments, the two replacement options—custom-made steel sash of a matching design, and bronze anodized aluminum double-hung sash—were too expensive for the project; the latter was less expensive but still cost on the average between \$400-450 per window. Furthermore, the use of double-hung sash in the large openings would have changed the historic character of the building.

For the required new window openings, a manufacturer of steel windows was located who offered a stock unit similar to the original design but with noticeable differences in the horizontal proportions and overall dimensions. These stock units were significantly less expensive than the custom steel windows and were selected for use in new openings since they were compatible with the heavy commercial style and character of the historic windows.

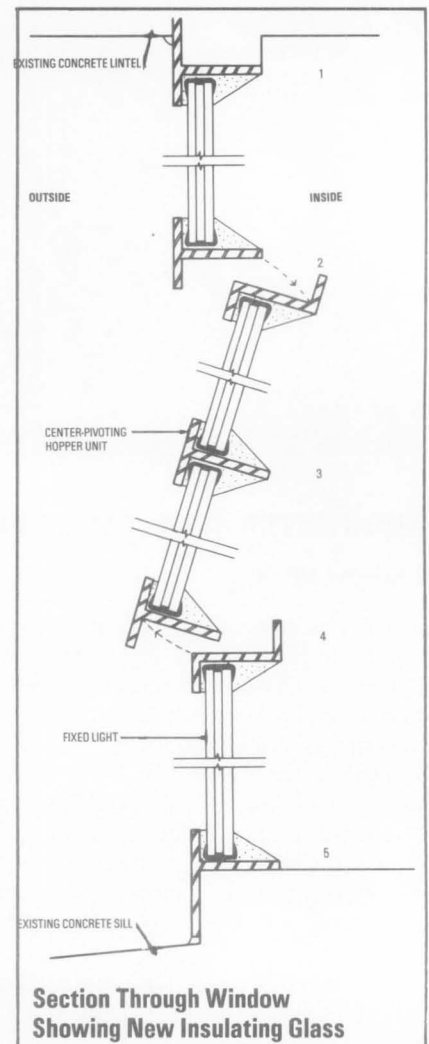
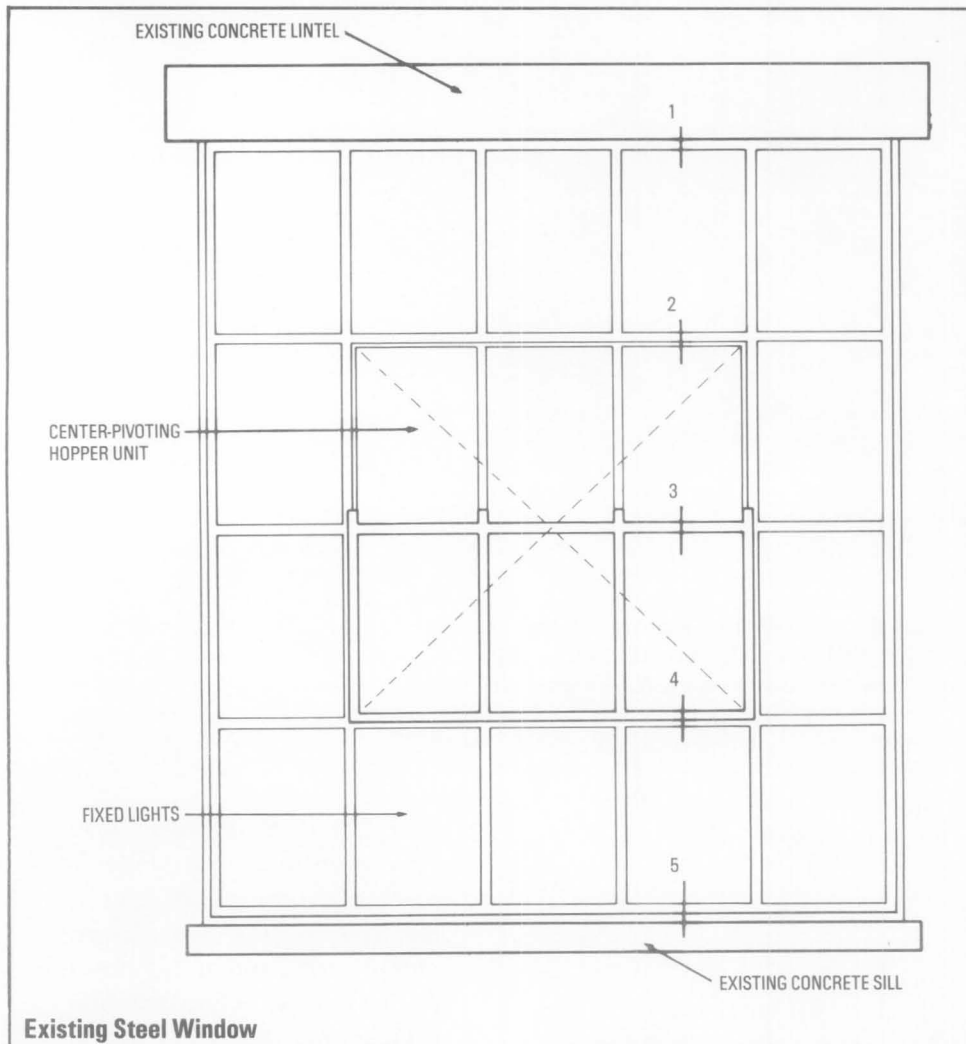

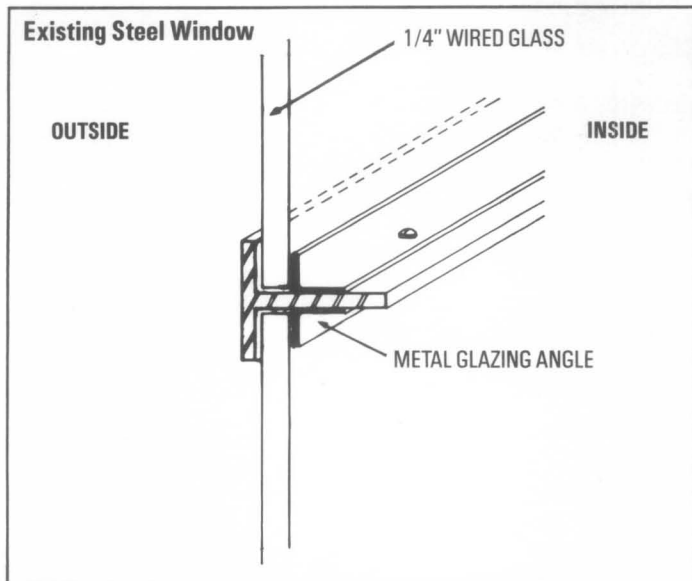

Figure 2. Spring glazing clips and face putty were used instead of the original metal glazing angles in installing the new glass. Drawings: Martha L. Werenfels

Window Rehabilitation Solution

The decision to repair the existing windows was based largely on the costs involved. Reglazing the windows using 3/8" insulating glass, ran approximately \$12 per double pane, while reconditioning the frames and hardware and repainting added another \$50-75 to the average cost of each window. The average cost of \$250 per window for this work was significantly lower than any of the proposed replacement units, and most of the repair cost was a result of the reglazing.

Only about half of the glazing cost was directly attributable to the use of insulating glass since from the outset, the residential use of the building tended to dictate from a marketing perspective that the existing wire glass be replaced. Thus it was decided that in lieu of only repairing and reglazing with clear 1/4" glass, which would have been the cheapest of the four identified window options, sufficient benefits could be derived by using double glazing to improve the window's energy performance (see figure 1).

In deciding what type of glazing to install, the depth of the T-shape muntin bar was a constraining factor. Since at least the 1930s, companies have been manufacturing double-glazed steel windows. In such cases, however, the depth of the muntin bars was usually greater than the 1 1/4" found on the windows in the Mergenthaler Linotype Building. By using 3/8" glass instead of the 1/4" wire glass, it was possible to use insulating glass in the existing windows, though an optimum distance between the double

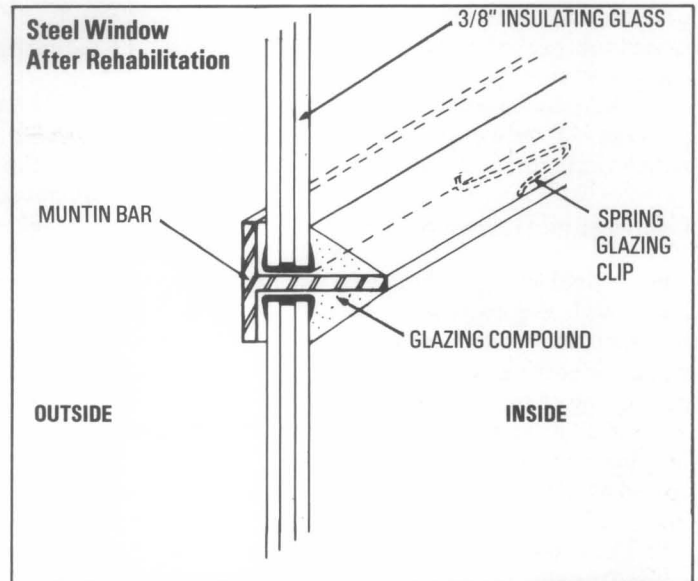

panes in terms of energy performance could not be obtained.

Thus it was decided that the cost of double glazing alone was justified considering the advantages derived from increased energy performance and reduced likelihood of condensation forming on the windows despite the new residential use. The double glazing also created no significant weight problem since 1/4" wire glass was being removed.

Preparation and Cleaning Work

After the metal glazing angles and glass were removed, the old frames were scraped off and existing paint layers and rust were removed using sand under air pressure. After cleaning, sections from several old windows that had been removed were welded into the remaining windows to replace missing

Figure 3. The historic steel windows were repaired and then upgraded through the addition of insulating glass. Photo: Charles E. Fisher

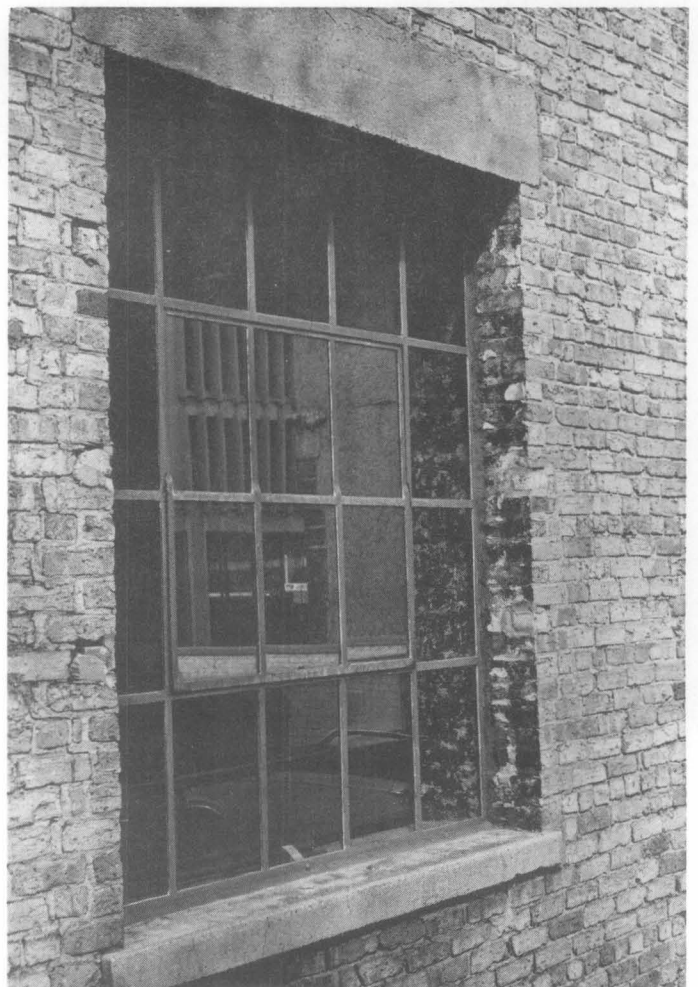

or deteriorated metal pieces. At the same time, racked metal sections, especially the center-pivoting hopper units, were realigned by applying heat and pressure. All the metal was then painted with an anti-corrosive paint.

Glazing and Hardware

The original wire glass had been held in place by glazing angles bolted to the muntin bars. In removing the glass it was decided, due to deterioration of the glazing angles and the labor-intensiveness of reinstallation, that new spring glazing clips and steel sash glazing compound would be used instead (*see figure 2*).

The insulating glass had been delivered to the site, vacuum sealed and with a continuous glazing edge. After the bed putty was applied to the sash, the insulating glass was installed with glazing clips and face putty.

New replacement handles and chains were readily found for hopper units where such pieces were broken, deteriorated or missing. After the windows were painted and caulked, there still was air infiltration around the hopper units, so adhesive-backed foam was added as weather stripping around the hopper unit.

Project Evaluation

There were no real unforeseen problems with the window work and the job was finished on time and within budget. Screens were not added to the windows although it would be possible to do so if individual residents felt there was a need. Condensation on the windows has not been a problem due to the use of insulating glass; reduced air infiltration after repair, caulking and weather stripping; the presence of a good heat source near the windows; and the southern exposure of the large windows.

On the whole, the reconditioned windows are performing well and are providing the desired improvements in personal comfort (*see figure 3*). There was no real problem in marketing the condominiums and residents have capitalized on the interior design opportunities provided by the large windows and the loft space.

The Mergenthaler Linotype Building rehabilitation has shown that the repair and upgrading of historic steel windows can improve energy performance in a cost-effective manner and that the light on the interior space from the large thin frame steel sash can be an amenity in residential conversions of loft buildings. Similar rehabilitation projects have shown that there are a variety of ways—both traditional and innovative—to preserve the character and design of historic steel windows and to have them function satisfactorily.

PROJECT DATA

Building:

Mergenthaler Linotype Building
531 South Plymouth
Chicago, Illinois

Developer:

Harper Realty
134 South LaSalle Street
Chicago, Illinois

Project Date: 1979

Architect:

Kenneth Schroeder, AIA
Kenneth Schroeder and
Associates
714 South Dearborn
Chicago, Illinois

Project Costs:

The average cost for repairing each window, installing insulating glass, reconditioning the hardware and finishing was \$250.

This PRESERVATION TECH NOTE was prepared by the National Park Service in cooperation with the Center for Architectural Conservation, Georgia Institute of Technology. Charles E. Fisher, Preservation Assistance Division, National Park Service, serves as Technical Coordinator for the TECH NOTES. Information on the window work at Mergenthaler Building was generously supplied by Kenneth Schroeder, AIA; we wish to thank him for his assistance. Special thanks also go to the following people who contributed to the production of this TECH NOTE: John H. Myers, Center for Architectural Conservation, Charles A. Parrott of the Lowell Historic Preservation Commission, and Preservation Assistance Division staff, particularly Martha L. Werenfels, Mae Simon, Michael J. Auer, and Martha A. Gutrick.

This and many of the TECH NOTES on windows are included in "The Window Handbook: Successful Strategies for Rehabilitating Windows in Historic Buildings" (available late 1984), a joint publication of the Preservation Assistance Division, National Park Service and the Center for Architectural Conservation, Georgia Institute of Technology. For information, write to The Center for Architectural Conservation, P.O. Box 93402, Atlanta, Georgia 30377.

PRESERVATION TECH NOTES are designed to provide practical information on innovative techniques and practices for successfully maintaining and preserving cultural resources. All techniques and practices described herein conform to established National Park Service policies, procedures and standards. This TECH NOTE was prepared pursuant to Federal tax laws which direct the Secretary of the Interior to certify rehabilitations of historic buildings that are consistent with their historic character; the advice and guidance provided in this TECH NOTE will assist property owners in complying with Federal tax requirements.

Comments on the usefulness of this information are welcomed and should be addressed to TECH NOTES, Preservation Assistance Division, National Park Service, Washington, D.C. 20240. This publication is not copyrighted and can be reproduced without penalty. Normal procedures for credit to the author and the National Park Service are appreciated.

ISSN: 0741-9023

PTN-2

January 1984