



**BUILDING 149
CONSTITUTION PARK
Boston Navy Yard
(Charlestown Navy Yard)
Boston, Massachusetts**

Building 149 is a 10-story 700,000 square foot reinforced concrete structure built during 1917-1919 for use as a naval warehouse and offices. It is located in the National Historic Landmark Boston Navy Yard, which was established in 1800 and which comprises approximately 130 acres and nearly 90 buildings associated with the naval shipyard operations. Portions of the installation now owned by the Boston Redevelopment Authority consist of sheltered shipways, warehouses, offices and residences. Vacant since the decommissioning of the shipyard in 1974, Building 149 recently has been renovated for use as offices and retail space by a private development firm under a long-term lease.

The building's fenestration—nearly 2000 steel window units set within 500 openings—was considered a very distinctive feature of the building. Through careful planning and attention to detail, an innovative aluminum replacement window system was developed by the project team that successfully maintained most of the distinguishing features of the original windows.

Problems

The inside-glazed, historic green-painted windows had narrow $\frac{7}{8}$ " wide

muntins with an exterior cove bead shape profile to the muntin. Most of the openings consisted of a bank of 4 side-by-side window units. Each of the middle two units consisted of 20 divided lites, including a 6-lite center hopper; the two end units were fixed and contained only 16 lites (see figure 1). Typical of pre-World War II steel windows, the glass panes had a narrower width than height. The vertical mullion connecting each unit was approximately 3" wide, noticeably dividing each opening into 4 window units.

The contractor's survey of the historic windows in the spring of 1984 revealed that extensive rusting of the frames had occurred and that many were racked. The severe rusting had also contributed to the spalling of sections of the concrete sills, jambs, and spandrels (see figure 2). Repair and upgrading options to maintain the historic windows were quite limited due to the size of the glazing bars. The shallow depth of the metal glazing bars (muntins) seemingly precluded the installation of sealed insulating glass within the existing lites, even if the windows could structurally support the additional weight. The only practical way of double-glazing would have involved the use of interior storms with units that were either operable or were removable for ease of cleaning. Even then, however, the severe deteri-

PRESERVATION

Tech Notes

NATIONAL PARK SERVICE
U.S. DEPARTMENT OF THE INTERIOR
WASHINGTON, D.C.

**WINDOWS
NUMBER 12**

**Aluminum
Replacements for
Steel Industrial Sash**

Charles E. Fisher
Preservation Assistance Division
National Park Service

**CLICK ANYWHERE on THIS
PAGE to RETURN to WINDOWS
& DOORS, AGE, TYPES,
INSPECT, INSTALL, REPAIR at
InspectApedia.com**

Every reasonable effort should be made to match the historic windows when replacement windows are required.

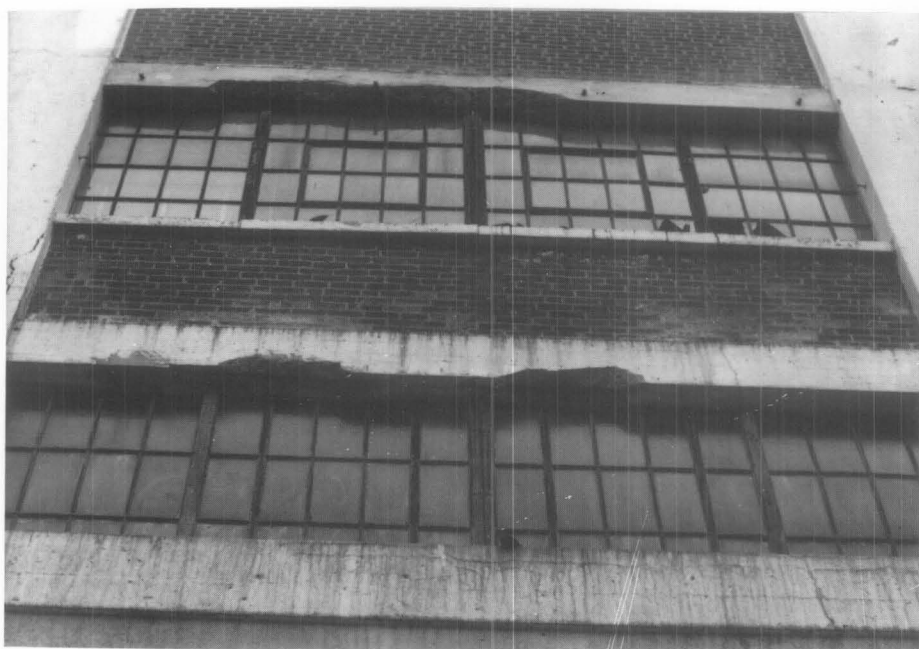

Figure 1. Most of the openings consisted of a bank of 4 side-by-side steel window units. Each of the middle two units consisted of 20 divided lites, including a 6-lite center hopper; the two end units were fixed and contained only 16 lites.

Photo: William MacRostie

oration of the steel windows still would have needed to be addressed. Considering the size of the bay openings, the decision was made to replace the windows.

Four replacement options were considered:

1. Replacement with matching steel units in combination with an operable interior storm window system.
2. Installation of large sheets of insulating glass, maintaining the principal 4-part division of each bay while eliminating the small multi-lite pattern which existed.
3. Installation of large insulating glass units, maintaining the principal 4-part division, and applying an exterior aluminum grid in an attempt to recapture the appearance of the historic multi-lite steel windows.
4. Development of an aluminum window system with true divided lites with insulating glass, maintaining as close as possible the profiles of the historic glazing bars and overall historic appearance.

The use of steel replacement windows was considered only briefly because a double-glazed system in such large openings would be high in cost, and would not be able to retain the narrow sight lines and profile of this particular type of steel window. The existing profile was available in a replacement steel window but could accommodate only single glazing, which was not considered adequate by the developer for energy purposes. Thus an interior storm window would have been necessary; however, the large size of the window openings would have required an expensive commercial storm window.

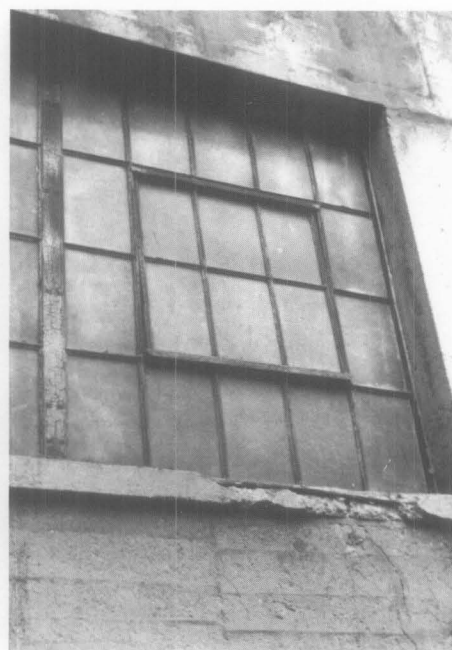

Figure 2. Due to lack of maintenance, severe rusting of the steel frames had occurred, which contributed to the spalling of sections of the concrete sills, jambs, and spandrels. **Photo: Charles Fisher**

A mock-up of the second alternative was installed, consisting of a fixed aluminum window with large sheets of insulating glass. Each opening had three vertical mullions, dividing the opening into 4 parts; this matched the principal division of the historic windows. Since the glass was not divided further into smaller lites, there was a dramatic change in the appearance of the building, and this alternative was quickly dismissed.

The third alternative, however, was seriously considered since it provided for an addition of an exterior aluminum grid applied to the face of the fixed aluminum window described in the second alternative. The grid was intended to simulate the appearance of the historic windows. The extruded aluminum grid would duplicate the cove-bead profile of the exterior portion of the historic glazing bars and would be attached directly to the glass, using a special epoxy glazing tape. This system had been used recently by at least one developer on a similar project. The estimated fabrication and installation cost of this window solution was \$1.1 million for the 500 openings.

The project director, Richard Graf of The Congress Group, Inc. (developer) and the Boston Redevelopment Authority (holders of the ground lease) both had reservations concerning the long-term performance

of the exterior aluminum grid. In the late 1970s there had been a number of projects where wooden muntin grids had been glued directly to the glass and where subsequent failure had occurred. Besides the question of the performance of glued-on aluminum grids, there were some visual changes that would result from the exterior applied grid compared to the original glazing bars. The Boston Redevelopment Authority was also concerned over the growing use of false muntins in the rehabilitation of large industrial buildings within the historic navy yard and the negative impact it was having on the overall architectural character of the district.

These collective concerns and the need for rapid approval of the rehabilitation plans led to the decision by the developer in May, 1985 to choose a fourth alternative: an entirely new aluminum window system.

True divided lites with insulating glass would be used as part of the new system with muntin profiles and framing members that closely matched the historic design.

Planning

The project architect and construction manager were responsible for preparing preliminary design guidelines for the new window system. Two local window contractors submitted bid proposals. One company proposed that the glass be exterior-glazed using inte-

gral muntins that were close to 1/4" in width. The other company showed an interior-glazed window and claimed that the integral muntin could be made as narrow as 1/16". Since inside glazing would facilitate both installation and maintenance, the decision was made to work with this company in the design of the windows to be used in Building 149. The contractor's bid this window system was \$1.4 million, which was approximately \$300,000 more than the applied grid.

Further development of the window system was required and the window needed to be performance tested—all requiring fast track scheduling. A development and construction team for the window work was assembled consisting of the following parties: the developer, the project architect, the window contractor, the window fabricator in Denver working with the window contractor, a testing laboratory in Boston that would assist with the performance needs and design of the window, the general contractor, a preservation consultant and an independent testing laboratory in Dallas responsible for final testing.

The engineering and design of the new window systems required close and frequent coordination between the various team members because of the number of important issues which needed to be resolved, all within a very short time frame.

One of the first major design issues to be resolved concerned the need to match as closely as possible the shape and dimensions of the original 7/8" wide glazing bar (muntin) with its decorative cove-bead exterior profile to simulate the profile of the original steel window muntins. The project team concluded that in order to keep the muntin on the aluminum window as narrow as possible, the traditional cast thermal break (cast plastic) feature of most modern windows could not be used. Instead, a series of spacers and gaskets principally would be utilized to achieve a thermal break for energy conservation. By using this approach, the window fabricator would be able to use a 1/16" wide integral cove-bead muntin. The only short circuit in the thermal break would be at the point where screws were used to connect the inner and outer portions of the muntin (see figure 3).

Besides the final detailing of the nonconventional thermal break, the representative from the local testing laboratory, was particularly concerned about water infiltration. A system was

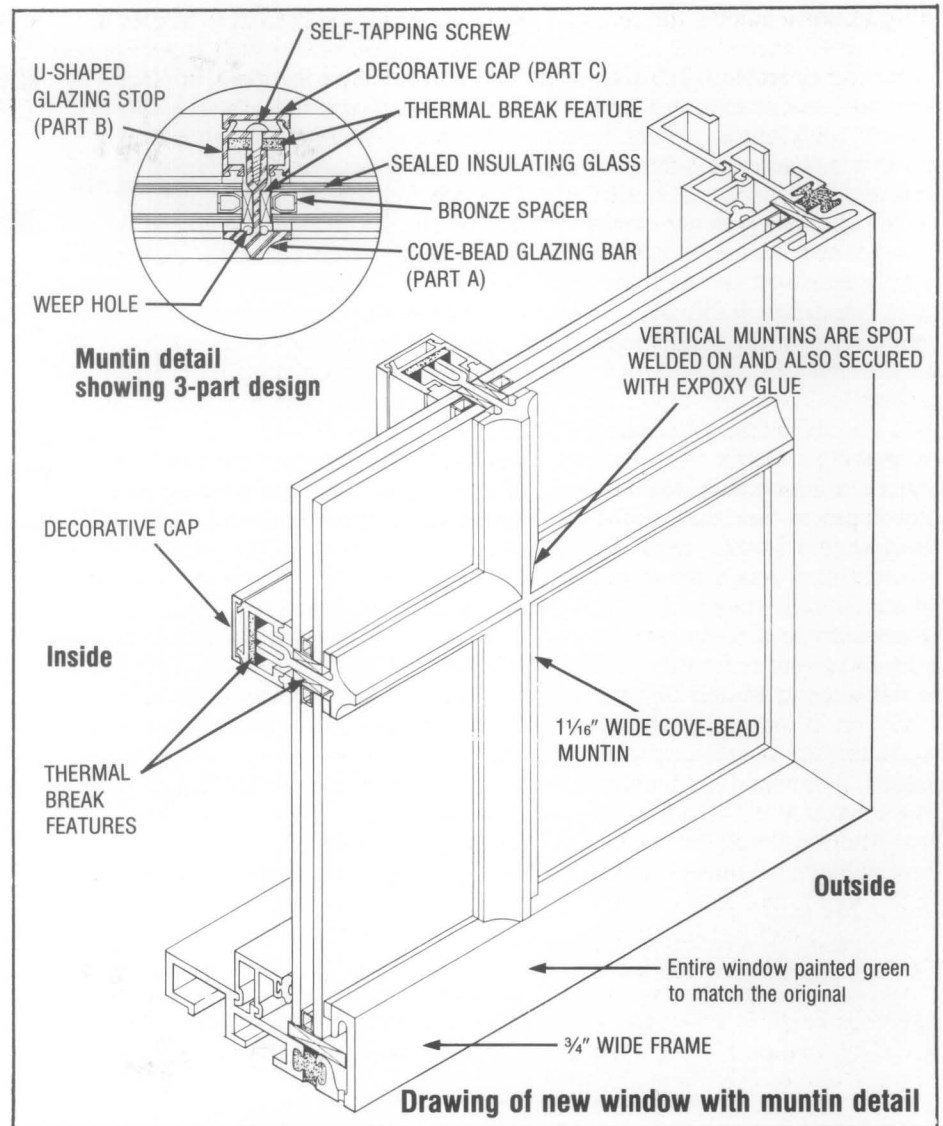

Figure 3. Drawing of the aluminum replacement windows shows how the cove-bead muntin profile of the original steel windows was closely matched in the integral muntin system designed for the aluminum replacement window. A series of spacers and gaskets were used as the principal means of obtaining a thermal break in the window for energy purposes. Drawing: Peter Charles

designed to ensure that moisture build-up behind the glazing tape would seep outside, rather than inside the building (see figure 3). A twenty-foot mockup was eventually constructed and successfully tested according to accepted industry standards.

A third important design consideration centered on how to keep the framing members and muntins narrow enough to maintain the thin profiles of the steel windows. The need for a thermal break in addition to the use of aluminum, which is structurally weaker than steel, necessitated some increases in sections and profiles. A technique more commonly found in skylight construction was used to hold the glass in place. This consisted of

screwing members together rather than using snap-on aluminum sections to secure the glass. Snap-on sections would have required more metal and wider profiles.

A fourth design and engineering issue arose with the construction detailing of the muntin joints. The decision was reached to face glue the joint on the front and spot weld behind. The fifth issue concerned the visual impact of the spacer used in the insulating glass. The original plans called for an aluminum spacer that turned out to be too shallow in width to properly glaze the sealed insulating unit. Since the acceptable width required a slight encroachment beyond the edge of the muntin, there was a concern over the potential visual impact. By selecting a bronze spacer, the metallic reflection that would have occurred from the typical aluminum mill finish was avoided and the visible portion of the dark bronze spacer was not noticeable from the street below.

The sixth design issue, which ultimately was not resolved, concerned

operability of the windows for ventilation. While there were some advantages to having operable windows, they were not paramount considering the building's new use as offices. With aluminum frames, a 6-lite hopper or projecting section as existed in the historic windows was not considered practical at that time. The primary reason was the need to keep the aluminum sections as narrow as possible to match that of the original steel. Given the structural requirements of an aluminum window, it was considered possible to fabricate only smaller operable units (1-3 lites). With the tight construction schedule, the additional development time that would be required, and the higher construction costs, the decision was made to proceed with a fixed window. This meant that there would be a noticeable change in one feature of the historic windows as a result of deleting the hopper section in the middle of two window units. The overall appearance of the new window and the building itself was judged to be sufficiently close to that of the historic appearance, however, that a marked change in character would not result.

The seventh and last major design decision concerned the number of pane divisions to be provided in each of the four sections of the window openings. The relationship of solids to voids (frame to glass) was important to retain. Since the muntins were to be increased in width from $\frac{7}{8}$ " to $1\frac{1}{16}$ ", discussions arose concerning possibly reducing the number of lites. Besides cost savings, changing the number of lites would help solve another problem stemming from plans to lower the sills due to the high sill height within the building. The lite pattern that was developed while reducing the number of lites, maintained the vertical orientation of the glass panes, and the proportion of solids to voids, further reducing any visual impact of the slightly wider aluminum muntins.

Window Design

The basic aluminum window unit consisted of 9 different aluminum extrusions, including the decorative cove-bead muntin. The muntin assembly actually consisted of 3 extruded aluminum sections. The principal muntin section was the cove bead portion that had a long glazing channel with a receptor at the end (see figure 3). Attached to the interior-facing side of the muntin was a U-shaped glazing

stop secured by self-tapping screws to the receptor on the cove-bead section. This stop secured the glass in place. For aesthetic purposes, the stop had a snap-on cover to hide the screws and create clean lines on the interior. Through the use of neoprene gaskets and plastic and neoprene spacers, a thermal break was achieved, broken only by the screws.

While the horizontal muntins were continuous across the window unit, the vertical muntins had mitre-joints where they intersected the horizontal muntins. The vertical muntins were secured through a combined use of epoxy glue and spot welding (see figure 4). A system of weep holes and channels was provided to ensure that any water trapped between the glazing tape and the glass and muntins would be diverted to the outside of the windows.

The overall window unit was not set into reglets as were the original steel windows but rather were bolted to the masonry because of the greater depth of the aluminum jambs. To keep the width of the frames sufficiently narrow to match the historic appearance, a $\frac{3}{4}$ " wide jamb was designed, narrower than standard window jambs (see figure 5). Due to high wind loading requirements for Boston, steel reinforcing bars were needed at certain corner windows, but other-

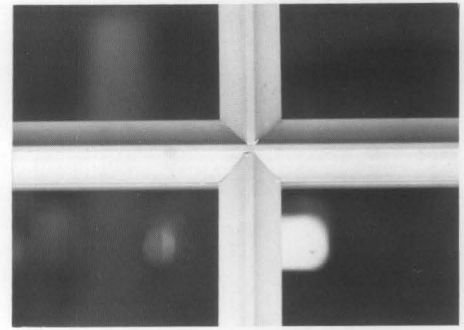

Figure 4. The vertical muntins had mitre joints where they intersected the horizontal muntins and were secured through a combined use of epoxy glue and spot welding. Photo: Charles Fisher

wise, the aluminum window system was designed and successfully tested with the narrow jambs.

Window Fabrication and Delivery

Through weekly meetings among the window project team, it was possible to provide for a rather complex manufacturing process for the overall windows that yielded cost savings and also met a very tight production schedule.

Figure 5. The frame of each window unit was designed with a width of $\frac{3}{4}$ " in order to closely match that of the original windows. The frames were bolted to the face of the jambs, sill, and head of the masonry opening. Drawing: Peter Charles

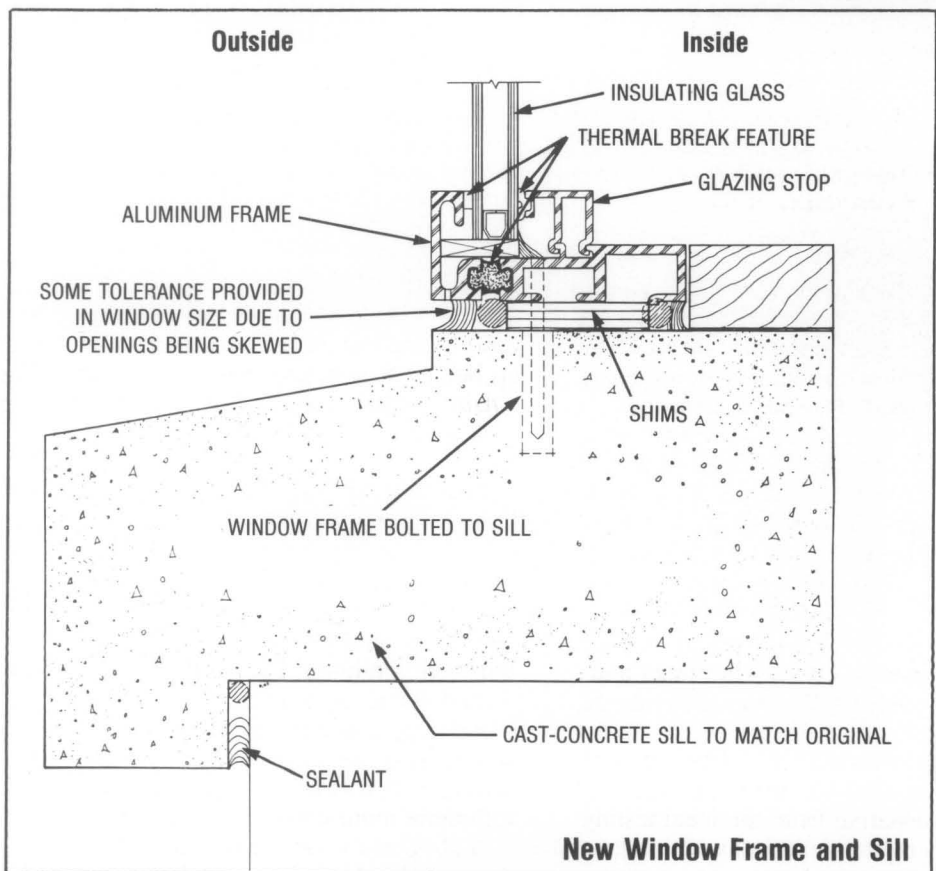

New Window Frame and Sill

The 9 extrusions required for the aluminum windows were manufactured in Portland, Oregon, and painted the historic green color in Salt Lake City; both companies had worked before with the fabrication plant. Fabrication took place in a window plant in Denver that previously had done work for the Boston-based window contractor. The fabrication work was complicated by the fact that there were a number of size variations for each of the 9 different types of windows in the building, although approximately 500 of the 2000 window units were the same size. The greatest variation occurred in the height rather than the width of the windows (see figure 6). A maximum of $\frac{3}{4}$ " tolerance was allowed around the sides of the overall window units in each opening; such tolerance was necessary because many of the openings were skewed.

While the windows were being manufactured, the tempered glass, required by the Fire Department, was cut in a plant in Tennessee and shipped to Easton, Massachusetts, where the glass was made into insulating units. The window contractor helped to coordinate all this work and was responsible for insuring that the glass was properly sized and that the spacers in the insulating glass did not encroach more onto the visible glass area than was specified. A number of the units had to be sent back to the glass assembly shop in Easton due to inaccurate sizing or misalignment of the bronze spacer. This work involved

Figure 6. Fabrication and installation of the window units were complicated by the nine different types of windows in the building and by the considerable variations in the window heights for each type. Approximately 500 of the 2000 window units were the same size. Photo: Chuck Parrott

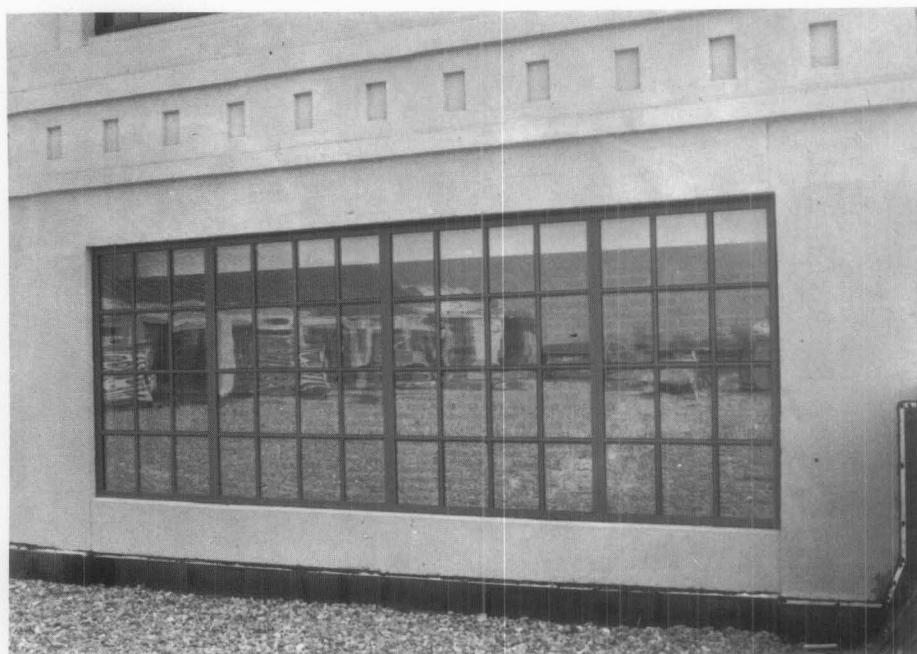

the greatest problem and biggest expense, since the limited tolerance for encroachment onto the glass area required very careful work (see figure 7).

Installation and Scheduling

While the windows were being assembled, the existing openings were being prepared. The work included the installation of all new cast concrete sills due to the lowering of the sill height. The windows were shipped to the site and installed unglazed.

The scheduling of the work reflected the fast track of the project as a whole. The decision to go with true muntins was made in May 1985; by June the general design of the window had been made and by July the final extrusion drawings were approved by the architect and consultant. By mid-August, the extrusion work was underway in Oregon and in September, the final testing by an independent laboratory in Dallas, Texas, was complete and the go-ahead for production was given. Fabrication started in September and the last of the windows were shipped from Denver in late December 1985. Installation of the windows began in January 1986 and final glazing was complete by June 1986, well in time to coordinate with the scheduled completion date.

The local window contractor was responsible for coordinating the extrusion and painting work, the window assembly, glass manufacturing and in-



Figure 7. Despite the difficulty encountered with proper glass sizing and spacer alignment in the sealed insulating glass, the end result is an innovative window that is both aesthetically pleasing and closely matches the historic appearance of the original steel design. The slight encroachment of the bronze spacer onto the visible glass area is not readily detectable from general view. Photo: Charles Fisher

stallation. Vital to the success of such complicated work was the close coordination and series of weekly meetings between the architect, developer, facade consultant, construction manager, and window contractor. During installation, the facade contractor—responsible for the rest of the exterior work—was also a participant.

Costs

The total cost of the window work was \$1.4 million. It was hard to estimate the total development cost of the new window system, although design and testing cost somewhat in excess of \$50,000. Despite the special work required and the complexity of the development and manufacturing work, the window system was only \$300,000 more expensive than the grid system initially proposed and subsequently abandoned due to performance and aesthetics considerations. The resulting windows cost approximately \$25 per square foot installed. Except for several changes at the building expansion joint, there were no cost overruns due to the window design. The window contractor, however, absorbed some unforeseen labor costs in this initial project.

Evaluation

The window work at 149 Constitution Park was noteworthy in several ways. First, it represented a significant improvement over past attempts to recapture the distinctive qualities of a steel industrial window with narrow cove-bead glazing bars, using an aluminum replacement system with insulating glass (see figure 8). Equally important was the manner in which the new window system was developed for the project.

The risks that were inherent in developing a totally new window system for a large rehabilitation were minimized by the team of highly qualified people; who coordinated closely and who kept to a tight schedule. The additional costs incurred in the development of the new window was not excessive considering the massive size of the project; the manufacturing and

installation of the new windows with true divided lites did, however, appreciably increase the cost of the window work. The results, however, are quite impressive and this innovative window system is commercially available for use in other projects.

This project shows just one way that significant improvements can be made on the quality of aluminum replacement windows used in historic buildings. The planning team involved in this project also identified further improvements that might be possible with this particular window system. While the new windows lack the hopper detail and altered the size and number of the muntins, many of the characteristics of the large steel industrial windows have been retained.

The project team were concerned not just with appearance but also with quality, engineering and high performance. This is important since poorly

built windows, whether old or new, can lead to excessive maintenance and high energy costs. The assembled team brought together the different professions and perspectives needed to produce an energy-efficient, cost-effective and aesthetically acceptable product.

While the window work was on a fast track from planning to completion, the decision to address the window issues early in the overall planning of the project provided the necessary lead time. Too often, window issues are addressed late in the planning of a project, providing little time to fully explore available treatment options. Where an innovative solution is necessary, as with 149 Constitution Park, extensive planning is crucial to the successful execution of the work.

Figure 8. The window work at 149 Constitution Park represented a significant improvement over past attempts to recapture the distinctive qualities of a steel industrial window with narrow-bead glazing bars, using an aluminum replacement system with insulating glass. Success was achieved through careful and well coordinated planning. Photo: Charles Fisher.

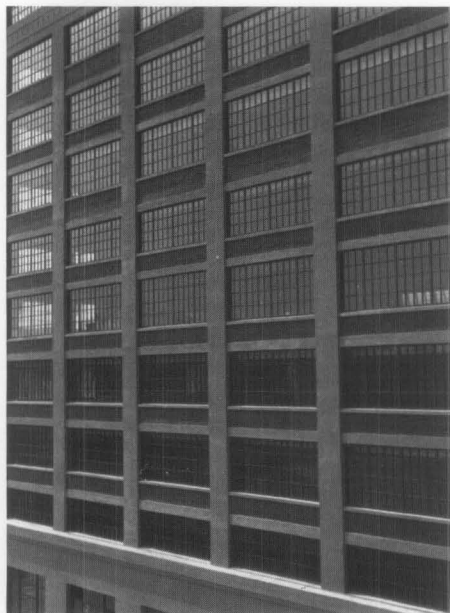

This PRESERVATION TECH NOTE was prepared by the National Park Service in cooperation with the Center for Architectural Conservation, Georgia Institute of Technology. Charles E. Fisher, Preservation Assistance Division, National Park Service serves as Technical Coordinator for the PRESERVATION TECH NOTES. Information on the rehabilitation work at 149 Constitution Park was generously supplied by Richard Graf, Project Director, The Congress Group, Inc. Thanks also go to Peter Charles, Architect, Center for Architectural Conservation, for the drawings appearing in this Tech Note and to the following Preservation Assistance Division staff who contributed to the production: Michael Auer, Brenda Siler, Kay Weeks, and Theresa L. Robinson.

6 Cover photo: Charles E. Fisher

PROJECT DATA:

Building:

149 Constitution Park
Charlestown Navy Yard
Boston, Massachusetts

Developer:

The Congress Group, Inc.
Boston, Massachusetts

Project Dates:

1985-86

Project Director:

Richard Graf
The Congress Group, Inc.
Boston, Massachusetts

Architect:

Amir Man
Project Architect
Huygens and DiMella
Boston, Massachusetts

Construction Manager:

Morse/Diesel
Boston, Massachusetts

Consulting Testing Laboratory:

Thompson and Lichtner
Boston, Massachusetts

Testing Laboratory:

The Dallas Laboratories
Dallas, Texas

Preservation Consultant:

William MacRostie
Heritage Consulting Group
Washington, D.C.

Windows:

Custom Windows
Denver, Colorado

L. Rubin Glass and Aluminum, Inc.
Saugus, Massachusetts

Project Costs:

The total construction cost of the window work was \$1.4 million or \$25 per square foot of window. There were additional development costs for the design and testing of the window which were approximately \$50,000.

This and other Tech Notes on windows are included in "The Window Handbook: Successful Strategies for Rehabilitating Windows in Historic Buildings; a joint publication of the Preservation Assistance Division, National Park Services and the Center for Architectural Conservation, Georgia Institute of Technology. For further information write to The Center for Architectural Conservation, P.O. Box 93402, Atlanta, Georgia 30377.

PRESERVATION TECH NOTES are designed to provide practical information on practices and innovative techniques for successfully maintaining and preserving cultural resources. All techniques and practices described herein conform to established National Park Service policies, procedures and standards.