



**Sears Roebuck and Company Mail Order Store
(Landmark Center)
Boston, Massachusetts**

The Sears Roebuck and Company Mail Order Store was constructed in 1928 in the Fenway section of Boston. Designed to meet the needs of traditional catalog sales and the company's rapid expansion into urban retail markets, the eight-story brick clad structure combined one million square feet of warehouse and shopping space. Retail activity was concentrated on the lower levels, while the upper six floors were devoted to processing catalog sales and providing warehouse facilities. The reinforced concrete framed structure has modest Art Deco detailing that is particularly prominent on the eleven story central tower and flanking piers that project above the roof parapet. Over 1,100 steel industrial windows were original to the structure. Placed individually or in groupings of two or three, most featured either a single projecting ventilator or a pair of stacked ventilators set within the multi-light window. Each vent in turn was typically divided into two or three vertical lights.

After more than a decade of disuse, a \$100 million rehabilitation was un-

dertaken in the late 1990s to convert the building into a mixed retail-office complex called Landmark Center. Through a process of evaluating the surviving windows and experimenting with various treatment solutions and design proposals, the decision was made to replace the majority of the windows while retaining and repairing units in select locations. A new custom aluminum window featuring true divided lights and insulating glass was developed that replicated both the interior and exterior details of the original units.

Problem

The design and placement of the original rolled steel industrial windows, manufactured by the now-defunct firm of David Luptonis Sons, contributed significantly to the historic character of the Sears building. Utilitarian yet distinctive, the windows reflected the dual function of the structure as warehouse and showroom. Of the building's seventeen window types, almost all shared some variation of the centrally located projecting ventila-

National Park Service
U.S. Department of the Interior



Technical Preservation Services

Preservation
Tech Notes

**WINDOWS
NUMBER 20**

**Aluminum Replacement
Windows for Steel
Projecting Units with
True Divided Lights and
Matching Profiles**

Chad Randl

Technical Preservation Services

**CLICK ANYWHERE on THIS
PAGE to RETURN to DOOR &
WINDOW INFORMATION at
InspectApedia.com**

Deteriorated architectural features should be repaired rather than replaced wherever possible. In the event replacement is necessary, the new windows should match the historic ones in design, color, size, configuration, reflective qualities, shadow lines, details and material. Only where it is not feasible to match the historic fabric should substitute window material be considered for use and only when it is shown through such means as mock-ups that it is possible to match closely both the detail and overall appearance of the historic windows.

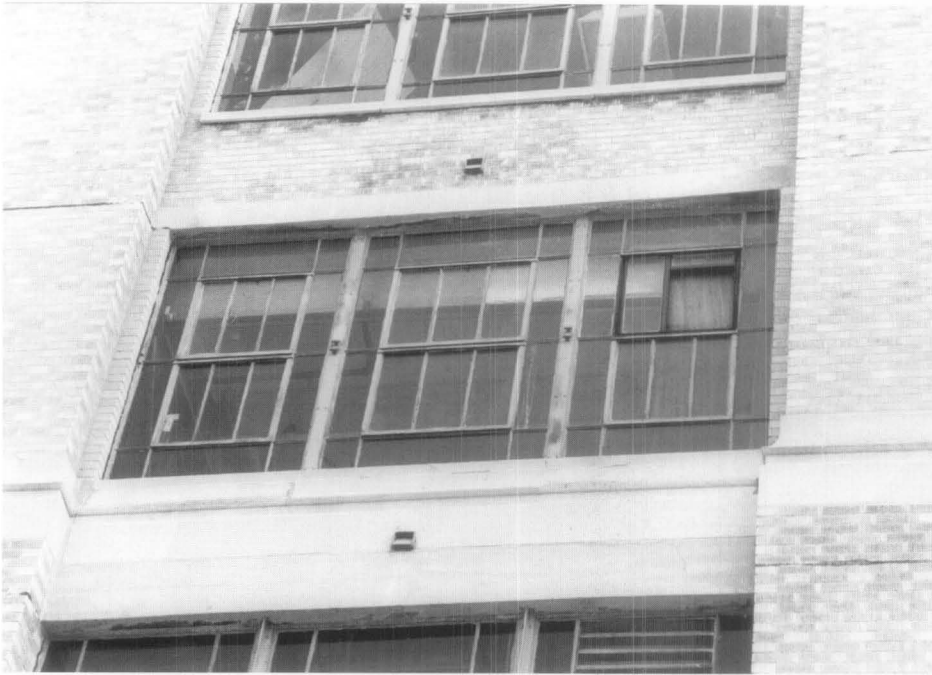

Figure 1. Many of the original Lupton windows incorporated a pair of stacked ventilators that projected outward. The vents were centrally located within a multi-light frame each of which was set either individually or in groups of two or three. Photo: Bruner/Cott & Assoc., Inc.

tor (or ventilators) framed by a group of fixed lights (*see figure 1*). Details such as muntin patterns, muntin widths and profiles, and the profiles of the operable vent were integral to the look of the windows and the building as a whole (*see figure 2*). Because of the distinctive character and prominence of the windows, any treatment plan required careful regard for the historic appearance of the original units.

A window inventory and condition survey was the first step in determining the most appropriate course of action. The assessment revealed that a majority of the original units had survived, though with varying degrees of wear, corrosion and other damage. Water penetration had led to deterioration along the interior glazing beads of the muntin in the ventilator. In some locations structural settlement had caused the window frames to rack and bend out of plumb making the vents inoperable. A number of windows had been altered to accommodate air conditioner units, including the removal of individual muntins. Accumulated layers of lead paint were common to all of the windows.

Beyond the condition of the existing windows, there were other factors that influenced the types of window treatment considered. Increased energy efficiency and aesthetics were two such considerations that were particularly important with the structure's function changing from primarily storage to office use. While the level of conducted heat flow through the existing single-glazed units was previously acceptable, the new office

use required greater climate control. Additionally, the original units did not meet stringent state energy code requirements. The conversion to office use, in which workers would be in close proximity to the windows, also strengthened preferences that the interior profiles remain clean and as accurate to the original configurations as possible.



Figure 2. Narrow sightlines, ventilator weathering flanges and mullion boltheads were all distinguishing features of the original steel windows. Photo: Bruner/Cott & Assoc., Inc.

Repair Options

From the outset, serious consideration was given to repairing the majority of the existing windows and upgrading the units for improved thermal performance. Any repair program had to be accomplished in situ, as the original window frames were embedded directly in the masonry surround without an intermediary subframe. Their removal for repairs or to salvage and substitute windows from one area of the building to another could only be achieved by cutting the frames free from the anchors, a process that would cause considerable damage.

If the windows were retained, energy efficiency could be increased by either of two alternative treatments: reglazing with insulating glass units, or installing interior storms. The former approach was quickly discarded when the thickness of the original steel muntin sections proved insufficient to support the added weight of new dual-paned glass units.

The second retrofitting option appeared more promising. To avoid obstructing the muntin arrangement of the historic windows, the proposed interior storm units had to be fashioned as single sheets extending from the head to the sill of each steel window. Installation of a mock-up, however, pointed out the limitations of the system. Because of the depth of their placement, the storm unit reflected the existing muntin pattern, creating a visually confusing appearance of two distinct grids.

A mock-up of the applied muntin system was fabricated utilizing available extrusions and was temporarily installed in the Sears building. The flat profiles of the stock extrusions did not, in this case, successfully recreate the historic window appearance. Had the applied muntin approach been adopted, it would have been possible to match the outside and inside profiles of the original muntin and such details as the drip moldings and grooves along the operable ventilators through the use of custom extrusions. However, because of the importance of the windows to the building's historic character, it was determined that only a true divided light solution would adequately reproduce the visual qualities of the original windows.

Solution

In the search for appropriate replacement units, an aluminum window manufacturer was contacted that had a track record of creating new systems for large historic renovations. The company was charged by the development team with providing an aluminum window that had true divided lights, matching profiles and sight lines, and insulating glass. The replacement system that was designed used a large number of new custom extrusions to replicate the dimensions, profiles and sightlines of the original windows (see figure 3). Individual insulated glass lights provided increased energy efficiency while more accurately recreating the characteristic variations of the original glass panes.

Existing historic windows in areas that were not to be continuously occupied, such as common lobbies and fire stairwells, were retained and repaired in situ. In addition, all of the tall windows on the second level (which would be devoted to retail functions) were repaired and reglazed where needed with historic glass salvaged from other locations in the building (see figure 4).

Fabrication

A significant challenge to developing the Sears building replacement window was matching the original narrow muntins. Common industry practice for true divided light aluminum windows was to utilize wider muntins that conceal the spacer bar in the insulating glass unit and protect the edge sealant from light degradation. This approach would significantly encroach into the sightlines of the original windows as a result of the wider muntin and proportion changes to the window. In the case of the Sears building, however, the window manufacturer utilized a narrow spacer bar that permitted an accurate

replication of the original 7/8" muntin (see figure 5). Substituting a dark bronze anodize finish further reduced the visibility of the spacer making it appear as a shadow line when viewed from an angle.

Each replacement window developed for the Sears building was fabricated from over forty new aluminum extrusions. The large variety of custom designed elements allowed for a faithful reproduction of the original profiles. At the request of the developer, the replacement windows were not operable, yet their appearance suggested the functional nature of the original projecting ventilators. Tabs were added to resemble the weathering flange closed flush against the fixed outer frame, while drip caps shielded simulated hinges. The muntin, rail, head, sill and jamb profiles were also accurately reproduced. In order to replicate shadows cast on the original frames, the manufacturer included cosmetic bolt heads on the mullions running between each of the paired and tripartite window arrangements.

The Inside Look

The inside appearance of the windows was important to the developer in marketing the new office space. A similar effort was made, therefore, to duplicate historic



Figure 4. Among the retained and repaired original windows were these large units on the second floor level. Photo: Bruner/Cott & Assoc., Inc.

interior details and profiles. As was typical of multi-story warehouses, historic steel windows were glazed on the inside so that the individual panes could easily be replaced when broken. To simulate

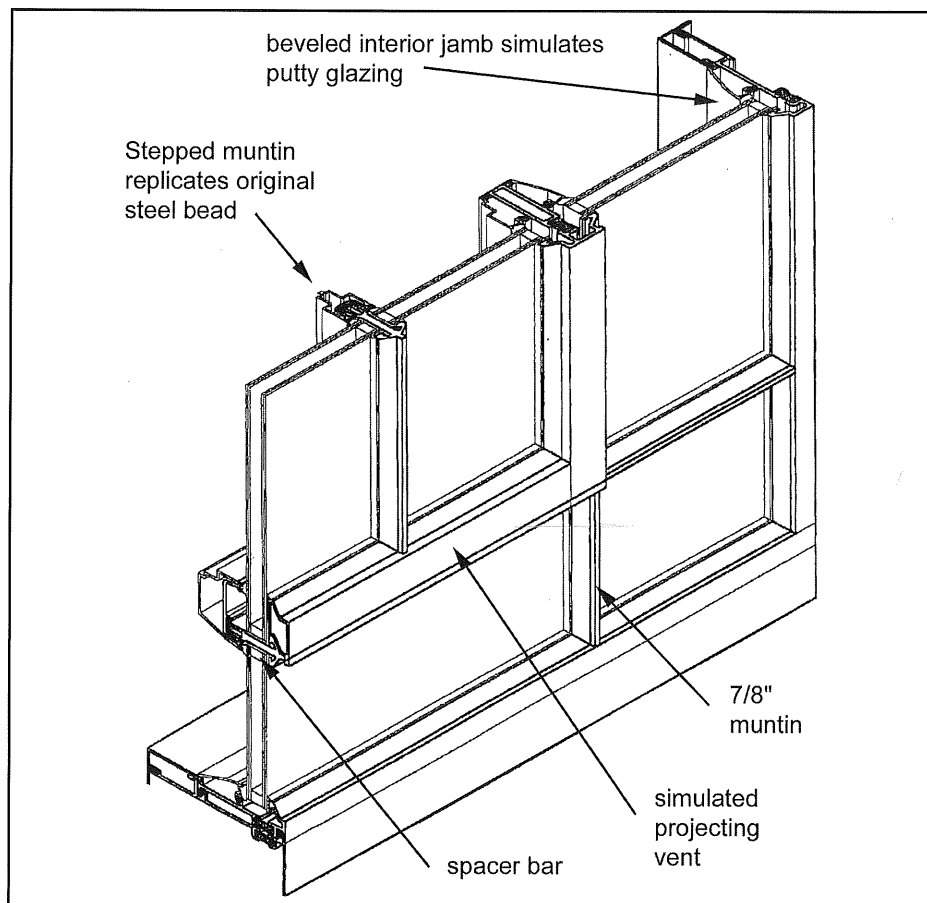

Figure 3. Isometric drawing of aluminum replacement window. Drawing: Greg Gibson.

the original interior putty profiles, the fixed-light muntins were tapered to the same 1/8" thickness of the original sections while stepped muntins were used in the central vent where steel beads had originally secured the glazing. Jambs in the replacement units were also beveled to recall the shape of the old glazing putty (see figure 6).

Testing and Installation

Being a new window system, the manufacturer had independent firms conduct standard performance tests on both the insulating glass and a mock-up of the complete window. In accordance with ASTM guidelines, tests on the complete window evaluated air infiltration, water resistance, and deflection and structural deformation under uniform load. With the test units meeting required specifications, window fabrication proceeded. Lengths of the new spacer were shipped to a glass fabricator where the insulating glass units were produced with a standard butyl and silicone dual-seal. Completed glass units were then shipped to the manufacturer for final assembly of each window.

While the new windows were being manufactured, a local contractor began the three month long process of stripping, repairing, repainting and reglazing the historic second floor windows and other retained units in stairwells and other non-office locations. As the new windows began to arrive in Boston, the general contractor removed the original units that were slated for replacement and a team of eight to ten workers started installing the new windows.

Evaluation

Decisions involving the treatment of the original Sears building windows were reached after understanding the significance of the windows' historic appearance and by evaluating their condition and the requirements imposed by the rehabilitated building's new function. Various proposals were explored to determine how well they reconciled these factors. The process suggested that the most appropriate solution was to retain approximately 18% of the original windows while replacing the remainder with aluminum true divided light units that carefully matched the originals in both detail and general appearance (see figure 7).

The replacement window system used on floors three through eight had two important advantages over earlier design proposals. First, it did not rely upon applied muntin grids that read less as individual glass 'panes.' Second, by developing new custom extrusions,

the replacement window successfully matched the dimensions and sightlines of the original muntins.

The design of the Sears building win-

dows demonstrates the degree to which aluminum windows with insulating glass units can accurately replicate historic windows.

Attention to seemingly small details such

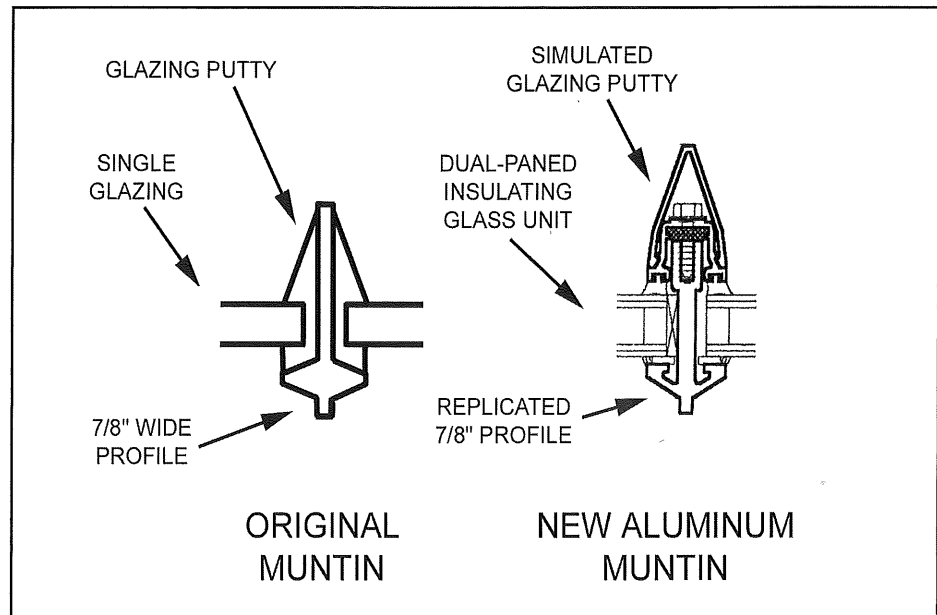

Figure 5. The replacement aluminum muntin accurately replicated original profiles while accommodating insulating glass and thermal stops. Drawing: Bruner/Cott and Custom Window.

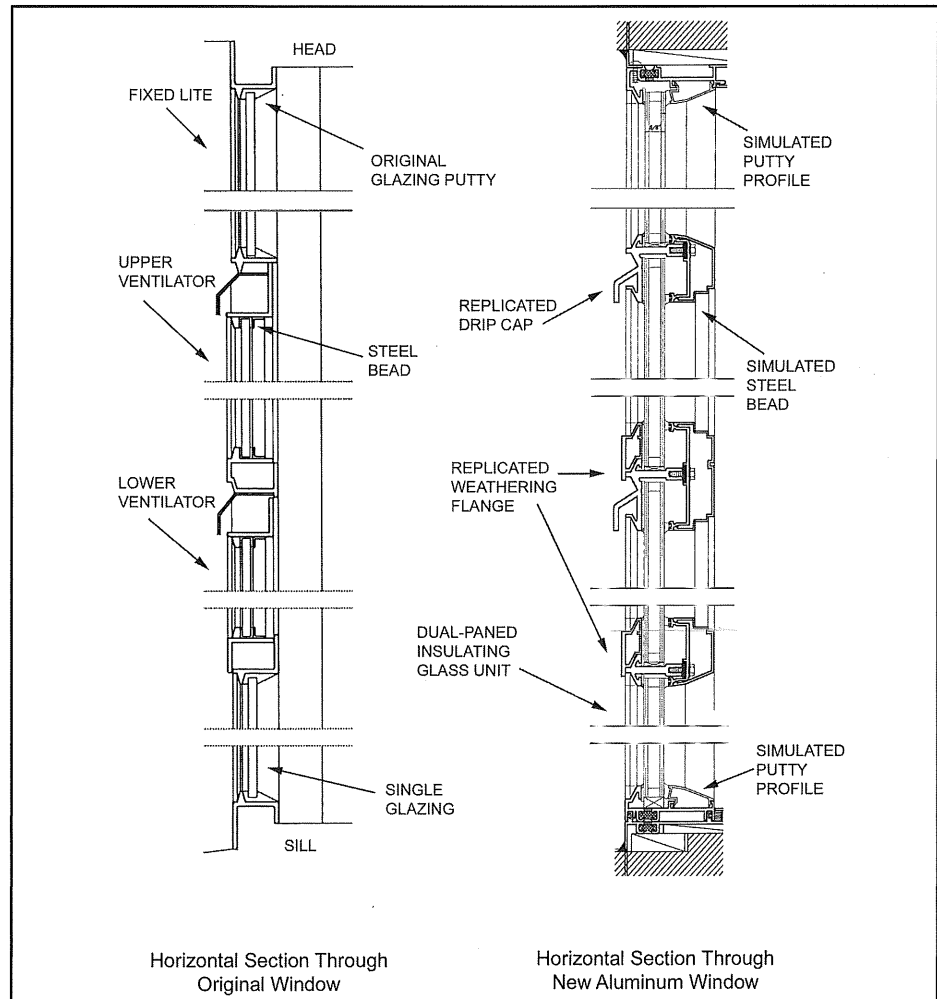

Figure 6. Sections of original and replacement windows. Drawings: Bruner/Cott and Custom Window.



Figure 7. Installed replacement window. Photo: Bruner/Cott & Assoc., Inc.

as drip caps and the interior appearance of the window proved crucial to the success of the replication effort (see figures 8 and 9). This understanding led to a new engineered window that met the challenge of combining narrow muntins with insulating glass units and true divided lights.

Although there were many advantages to the window scheme developed for the Sears building several drawbacks should also be acknowledged. One of the most significant disadvantages was the loss of historic material and integrity that accompanies any window replacement. In this case, the loss included steel frames and glazing that were removed as well as the functional nature of the once-operable projecting window.

While the replacement window frames are virtually indistinguishable from the original frames, the uniform, factory-produced nature of the units is in contrast to the look of historic steel windows that have aged over time. Also, the true divided lights, though superior in appearance to large insulating glass units with applied muntins, still have the reflective quality of modern insulating glass.

A final concern, relevant to all dual-glazed replacement windows, involved the integrity of the insulating glass unit seals. Although the dual-seal used in the Sears building replacement windows is currently state-of-the-art, the lifespan of insulating glass units in general has varied widely and is undoubtedly shorter than traditional monolithic glazing. The combined effects of the true divided light design and the narrow spacer bar suggest that the Sears building windows be



Figure 8. A close up view of the replacement window showing the replicated ventilator drip cap and narrow muntins. Photo: Bruner/Cott & Assoc., Inc.



Figure 9. The interior profiles of the original windows were accurately reproduced in the aluminum replacement units. Photo: Bruner/Cott & Assoc., Inc.

periodically inspected. Small divided lights significantly increase the perimeter area that is sealed and thus vulnerable to degradation while the narrow spacer reduces the amount of sealant that can be

accommodated along that perimeter. A ten-year warranty is currently being offered by the glass fabricator for the window system.



Figure 10. The replacement windows designed for the Sears building rehabilitation met energy efficiency and aesthetic goals while providing for the continued historic appearance of the structure. Photo: Bruner/Cott & Assoc., Inc.

Conclusion

The Sears project illustrates that a combined approach of window repair and replacement with a custom window designed to match the historic unit is a viable alternative when large-scale building rehabilitation is undertaken (see figure 10). Such a solution provides the opportunity to retain significant historic fabric and a wholly authentic original appearance in the most visible locations. In areas where the original windows have experienced significant deterioration, are in less prominent locations and where there are no suitable alternative means of enhancing thermal performance, replacement windows that are intended to match the originals in detail and appearance are acceptable. The window solution devel-

oped for the Sears building acknowledges modern demands for both a marketable aesthetic appearance and increased energy efficiency while retaining the historic visual appearance of the structure. Already the custom replacement window developed for the Sears building is being installed on other historic buildings with comparable windows that are deteriorated and in need of replacement.

PROJECT DATA:

Building:

Sears Roebuck and Company Mail Order Building
(Landmark Center)
309 Park Dr. & 201 Brookline Ave.
Boston, MA 02215

THE PRESERVATION TECH NOTE was prepared by the National Park Service. Charles E. Fisher, Heritage Preservation Services, National Park Service, serves as the Technical Editor of the PRESERVATION TECH NOTES. Information on the window work at the Sears Mail Order Building was generously supplied by Leslie Donovan, Tremont Preservation Services; Henry Moss and Simon Tempest, Bruner/Cott Architects; Edward Bartlett, Custom Window Company; Jim Kfoury, JK Glass; and Alan Aulson, Aulson Company. Thanks also go to Sharon Park and JoEllen Hensley of the National Park Service's Heritage Preservation Services for their review and comments.

PRESERVATION TECH NOTES are designed to provide practical information on traditional practices and innovative techniques for successfully maintaining and preserving cultural resources. All techniques and practices described herein

Owner:

The Abbey Corporation
Boston, Massachusetts

Project Date: 1996-2000

Project Architect:

Bruner/Cott and Associates, Inc.
Boston, Massachusetts

Restoration Consultant:

Leslie Donovan
Tremont Preservation Services
Boston, Massachusetts

Window Manufacturer:

Custom Window
Denver, Colorado

Window Contractor:

JK Glass
Boston, MA

Project Cost:

The project's size and budget were sufficient to absorb the added expense of developing the new window system and its numerous custom extrusions. Engineering time and the cost of tooling and producing new extrusion dies for the Sears project totaled approximately \$25,000. As additional \$15,000 was spent on mockups and testing, bringing the development cost to approximately \$45 per frame in 1998 dollars. The total expenditure for replacement window work including all development costs, installation labor, perimeter caulking, dealer markup and the 890 window units themselves came to approximately \$1.75 million, or \$1,966 per window. This figure does not include expenses associated with removing the original units. Repairing and repainting the two hundred windows that were retained on the second floor and along the stairwells cost an additional \$158,000, or approximately \$800 per unit. The overall rehabilitation cost for the building was approximately \$100 million.

conform to established National Park Service policies, procedures and standards. This Tech Note was prepared pursuant to the National Historic Preservation Act Amendments of 1980 which direct the Secretary of the Interior to develop and make available to government agencies and individuals information concerning professional methods and techniques for the preservation of historic properties.

Comments on the usefulness of this information are welcomed and should be addressed to PRESERVATION TECH NOTES, Technical Preservation Services, National Center for Cultural Resources, National Park Service, 1849 C Street, NW (2255), Washington, DC 20240.