

# INTREPID TRDV Series

DIRECT VENT OIL-FIRED WATER BOILER

## VENTING INSTALLATION INSTRUCTIONS

CONTENTS . . . . .	PAGE
Basic Guidelines . . . . .	1
Application (Flex-L Vent Terminal)	
Direct Vent Applications . . . . .	2 & 3
Installing the joint assembly . . . . .	4
Outside Terminal	
Installing the outside terminal . . . . .	5
Connections to the outside terminal . . . . .	6
Connections to appliance . . . . .	7
Maintenance . . . . .	8
Vent system part numbers . . . . .	8
Alternate Field Controls Vent Terminal . . . . .	8-14

**Slant/Fin TR SERIES, models TRDV are approved for installation as a direct vent system. The following basic guidelines should be observed according to the venting system in use. In addition, it is strongly recommended that the applicable precautions for Natural Draft Applications be used.**



**FIGURE 1: Slant/Fin model TRDV oil boiler with vent kit**

### Installation Considerations

In addition to all the pertinent information regarding Natural Draft Applications whenever a Mechanical Draft Application is used it should be installed using the following instructions and Figures 2 and 3 as reference.

- The terminating vent hood, and the inlet air hood are on the same wall surface, and are on the wall opposite from the prevailing wind wall, if possible.
- All of the air for combustion to the burner is supplied directly from the outside of the building or structure.
- Not less than 12 in. above the total accumulated snow and level grade.
- Not less than 4 ft. horizontally or below any window, and door or air inlet and also not less than 1 ft. above any of these openings.
- Not less than 3 ft. above a powered air inlet device that is within 10 ft.
- Not less than 2 ft. from any other building.
- At least 3 ft. from any inside corner of a building
- At least 1 ft. from any roof soffit or ridge vent.
- At least 7 ft. above any public walkway.
- All of the vent construction consists of suitable materials, and terminates at an approved stainless steel hood.
- All of the vent piping must be sealed from air leaks.
- The vent pipe bend radius is 12 in.
- Brace metal strapping every 36 in. to support vent pipe and prevent it from sagging.
- Follow the national codes for the installation of oil burning equipment in USA-NFPA 31, in Canada CAN/CSA - B139 and local regulations.

### FLEX- VENT TERMINAL

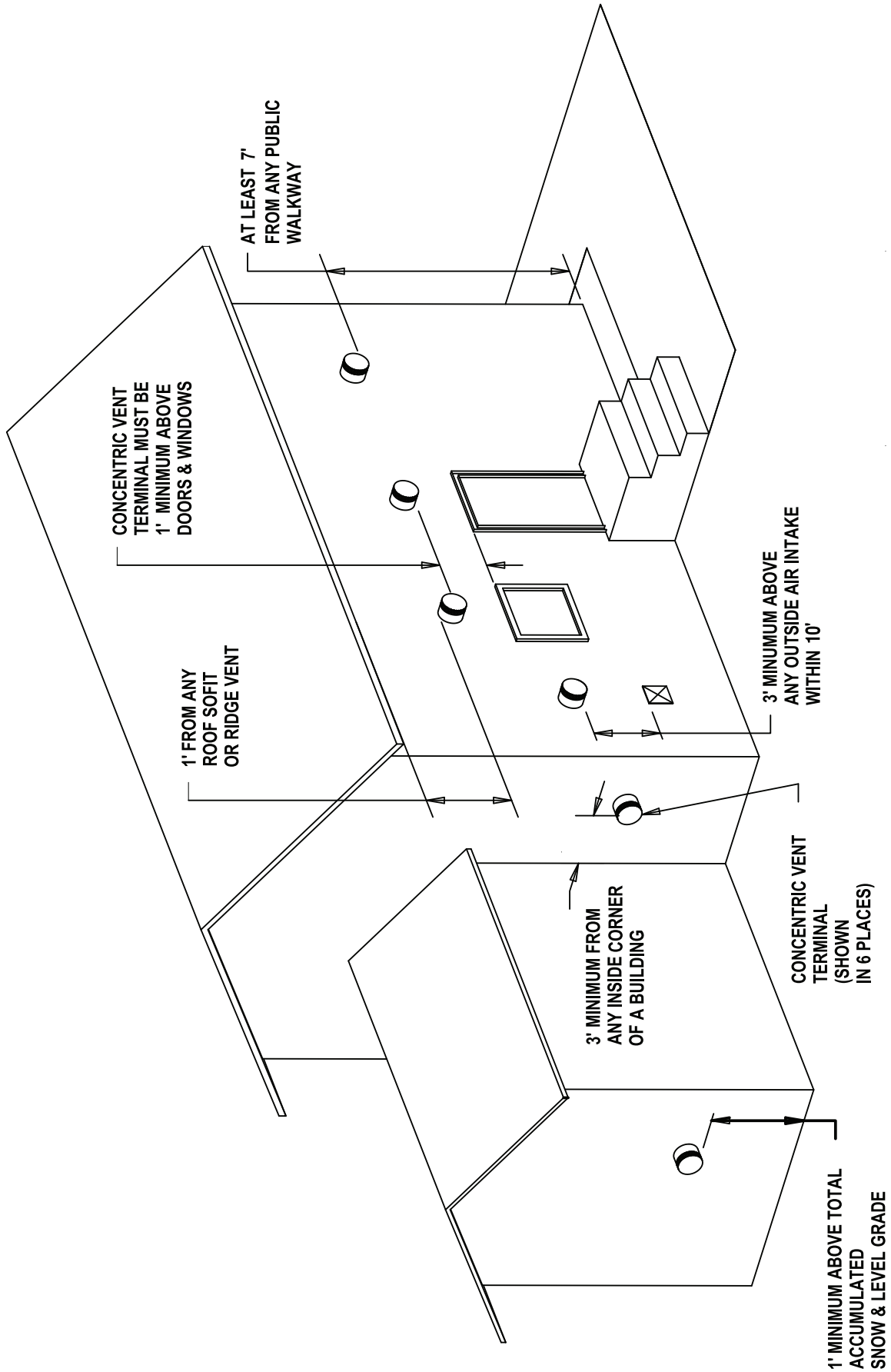
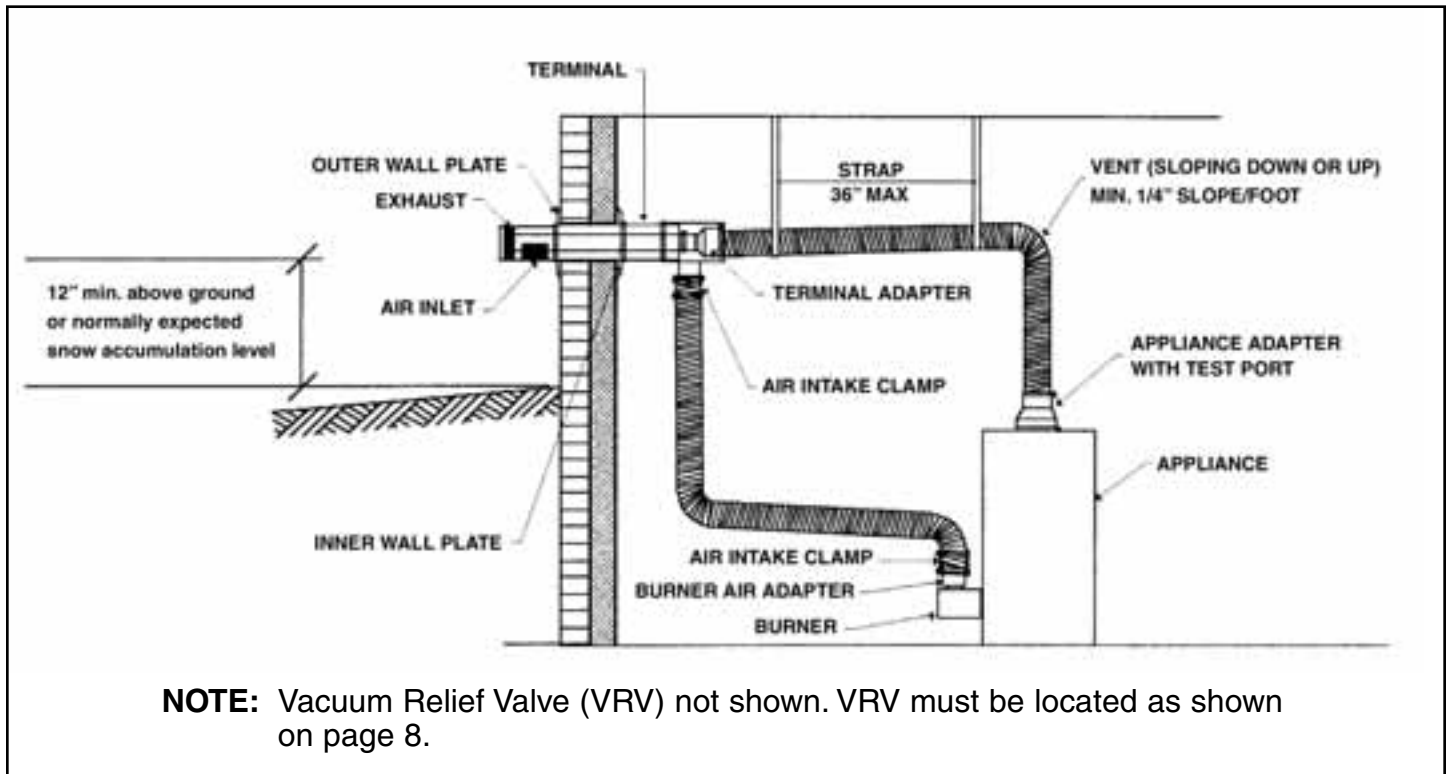

FIGURE 2: Vent terminal installation locations

## FLEX- L

**Do not install vent terminals on prevailing wind wall side of structure. Moisture and ice may form around terminal. Make sure the surface is in good repair and protected from damage.**

**Slant/Fin models TRDV boilers can be installed on sealed or direct vented systems. They must be ordered from the factory with an approved Direct Vent System. Part numbers for the kits and accessories can be found on page 8 of this manual.**



**FIGURE 3: Typical installation**

**ADDITIONAL INSTALLATION CONSIDERATIONS (Figures 2 & 3)**

- 1) Kit or system may vary based on specific needs of appliance.
- 2) Utilize the appliance adapter test port for combustion testing required by appliance manufacturers.

The vent terminal has a 0" clearance to combustibles  
 The insulator to vent pipe has 1" clearance to combustibles.

## FLEX- L

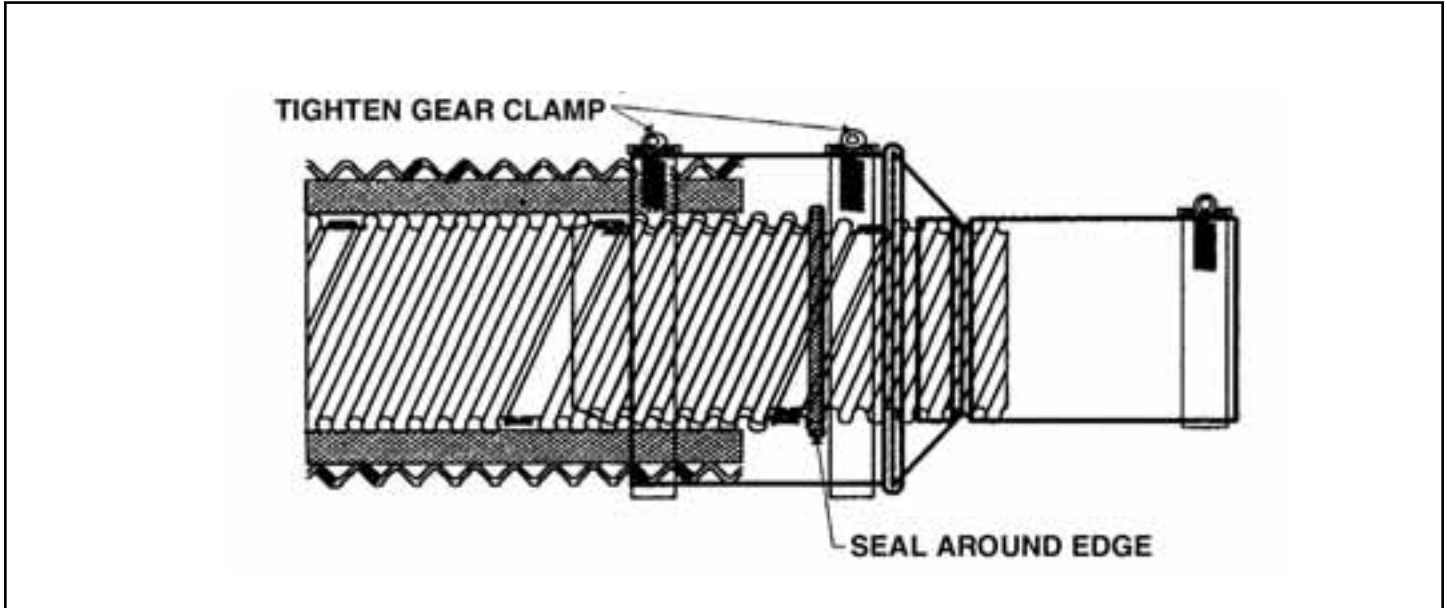

FIGURE 4: Joint assembly

## INSTALLING THE JOINT ASSEMBLY

1. Loosen the gear clamps attached to the adapter sleeve and slide the adapter sleeve over the vent pipe, Figure 4 and Figure 5.
2. Pull the corrugated inner tube out of the vent pipe for easy access and insert the adapter.
3. Apply sealant around the corrugated end of the adapter.
4. Align the flat seams at the end of both corrugated tubes and insert the adapter into the vent tube. Screw the adapter into the vent pipe with a counter-clockwise motion. The adapter should be fully inserted into the inner vent tube until it's tight. The seams of both tubes must be aligned for ease of insertion. If the adapter does not completely screw into the vent pipe, unscrew it and try again as per Step #4.
5. Seal around the edge of vent pipe inner tube.
6. Slide the adapter sleeve back onto adapter and tighten the gear clamps to complete the connection.
7. If the vent requires cutting to length, a fine tooth hacksaw can be used. Remove any burrs and flare out the end of the inner vent tube for easy installation of the adapter.

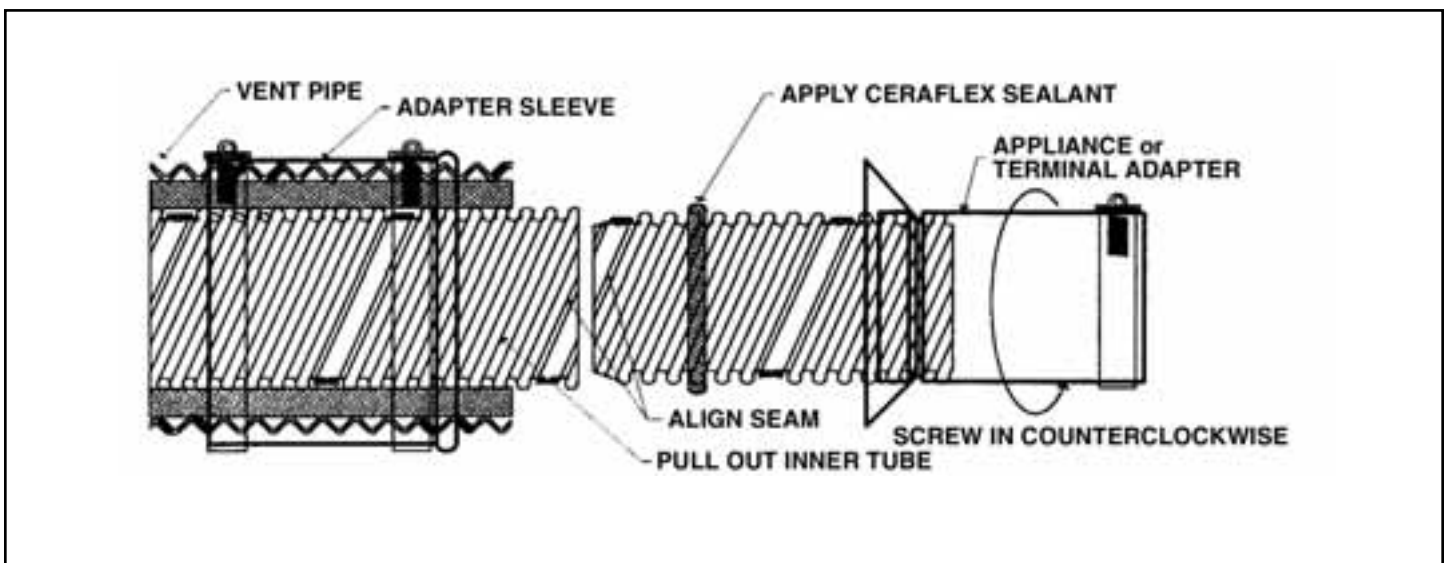

FIGURE 5: Joint assembly

## FLEX- L

## INSTALLING THE OUTSIDE TERMINAL

The maximum wall thickness be no more than 14 in. Contact Slant/Fin for recommendation in case of a thicker wall.

The system is not designed for common venting. Use for a single appliance only.

Use Figure 6 and Figure 7 to complete the following steps.

1. Determine the terminal location.
2. Cut 8-1/4in. diameter hole through the wall (slightly larger than the O-D. of the terminal)
3. Pull apart the inner and outer terminal sections.
4. Slide the outer wall plate over the outer section of the terminal until it rests against the bead.
5. From the outside of the building, insert the outer section through the hole until it resets against the wall.
6. From the inside of the building, slide the inner wall plate over the outer and secure using the (4) screws.
7. Position the outer section so the seam on the flue collar is on the top and the air intake on the bottom. Secure the outer section by tightening the gear clamp around it. The gear clamp is factory welded to the inner wall plate.
8. Seal with a weather proof sealant around the bead and edge of the outer wall plate to prevent water from getting inside.

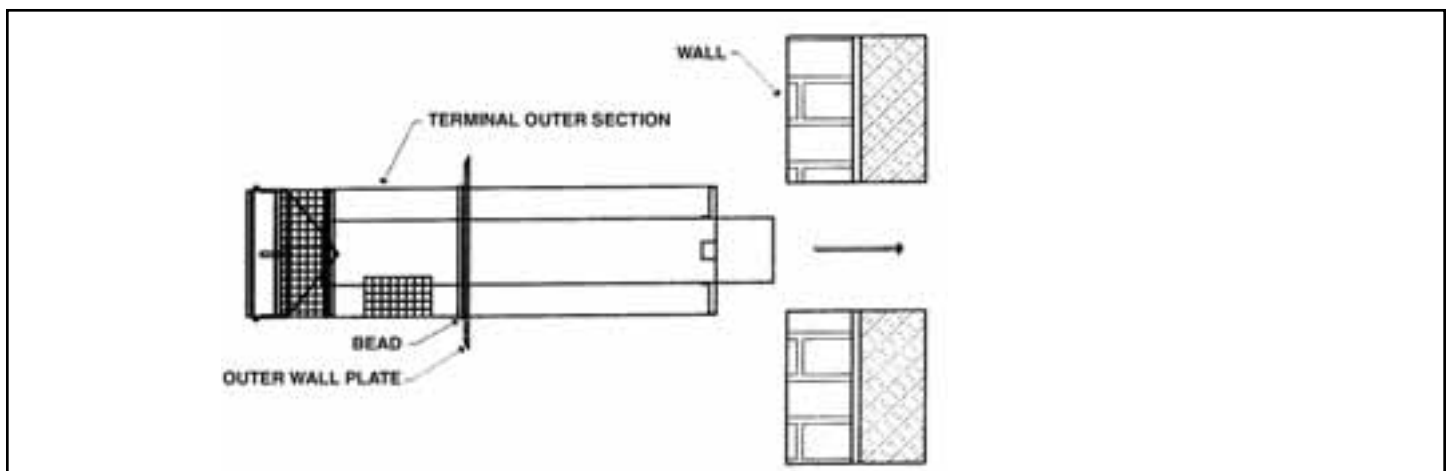

FIGURE 6: Vent terminal installation into wall

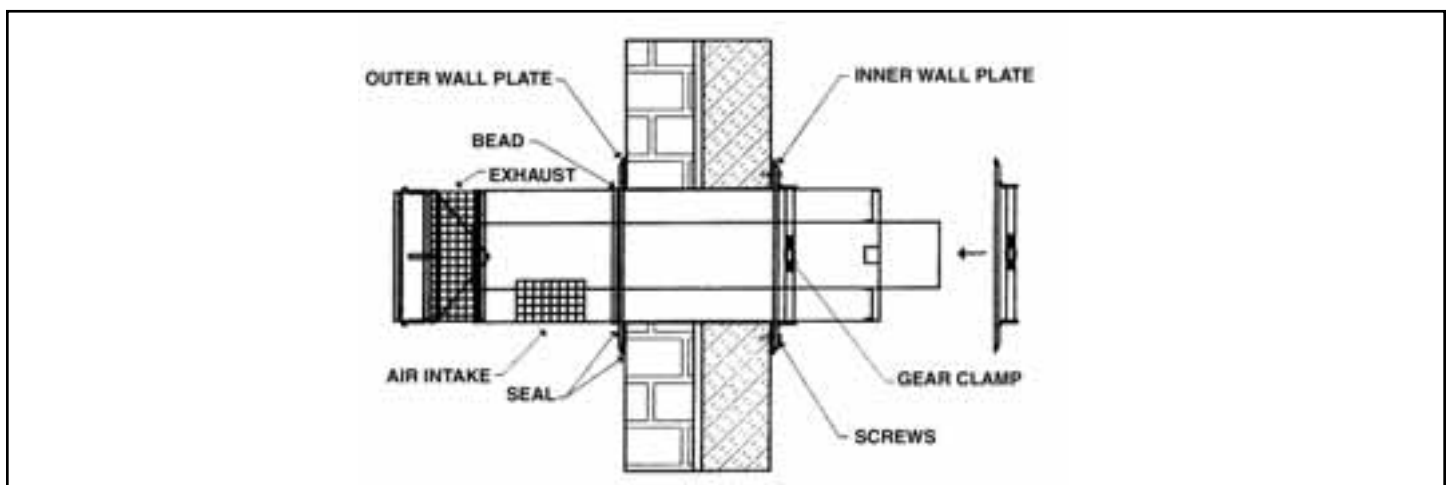

FIGURE 7: Vent terminal mounting

## FLEX- L

### CONNECTIONS TO THE OUTSIDE TERMINAL

Use Figure 8 and Figure 9 to complete the following steps.

1. Slide the inner section over the vent pipe.
2. Connect the inner adapter to the vent pipe as per joint assembly.
3. Apply a bead of sealant around the terminal flue collar.
4. Slide the appliance adapter over the flue collar
5. Tighten the gear clamp of the terminal adapter around the flue collar.
6. Seal the seam in the adapter with sealant.
7. Slide the inner section over the outer section and secure by tightening the gear clamp.
8. Air intake piping is field supplied and must be installed according to local code requirements. Galvanized flue pipe or Flex L air intake piping can be used. For optional Flex L air intake piping, stretch the air intake flex to desired length and slide over the air intake collar. Seal the connection with the aluminum tape and secure using air intake clamp. Beaded end of (Figure 7) the air intake clamp should go first over the air intake collar.
9. All seams and gaps should be sealed. For the Flex L piping, seal the gap between the vent pipe and the inner section with silicone sealant.

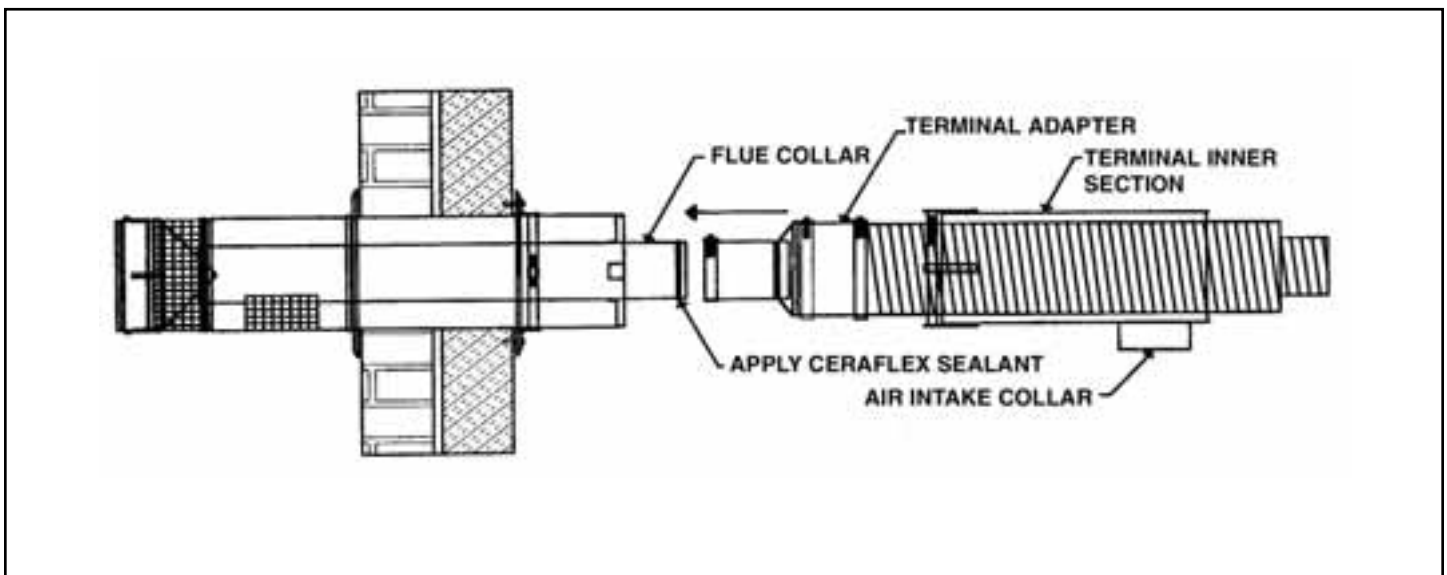

FIGURE 8: Vent terminal to flue pipe connection

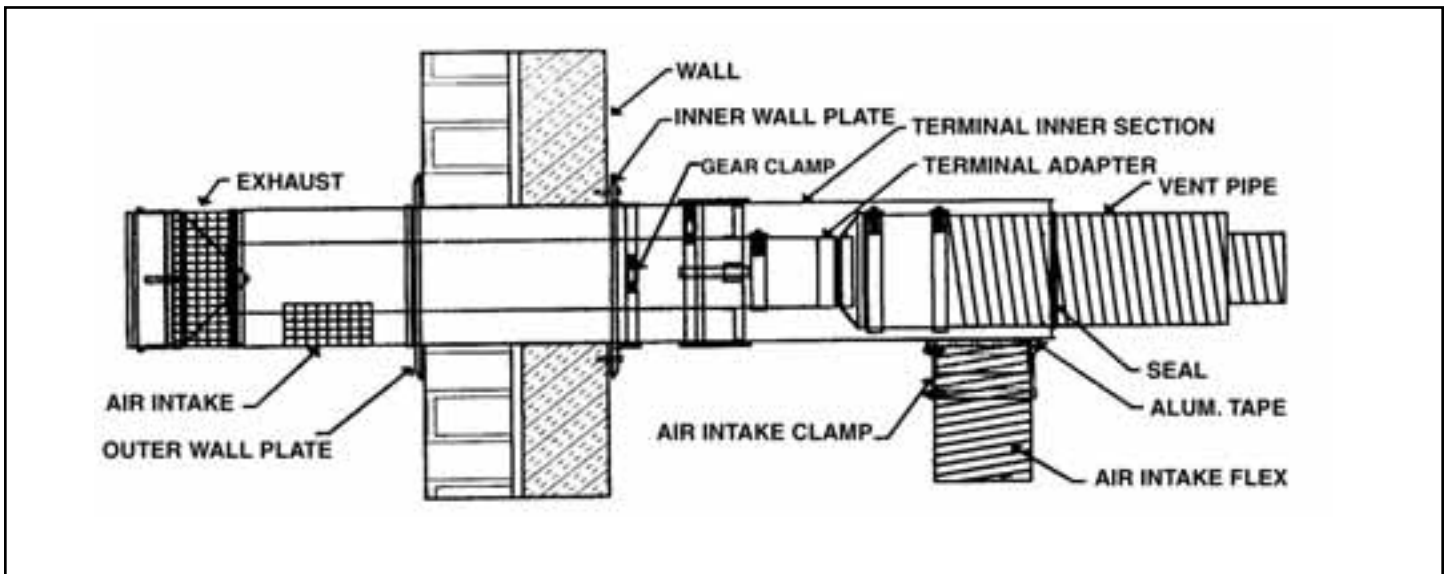

FIGURE 9: Connection to fresh air intake

## FLEX- L

## CONNECTIONS TO APPLIANCE

Using Figures 10 and 11 complete the following steps:

1. Connect the appliance adapter to the vent pipe as per joint assembly.
2. Apply a bead of sealant around the appliance flue collar.
3. Slide the appliance adapter over the appliance flue collar.
4. Tighten the gear clamp of the appliance adapter around the flue collar.
5. Seal the seam in the adapter with sealant.
6. Install burner air adapter.
7. Air intake piping is field supplied and must be installed according to local code requirements. Galvanized flue pipe or Flex L air intake piping can be used. For optional Flex L air intake piping, stretch the air intake flex to desired length and slide over the air intake collar. Slide the end of the air intake piping over the burner air adapter. Seal the connection with aluminum tape and secure using air intake clamp. Beaded end of the air intake clamp should go first over burner air adapter. See figures 12-13 on the bottom of this page.
8. A vacuum relief valve must be installed on the air intake side of the venting system. Locate the vacuum relief valve as close as possible to burner inlet. Follow the vacuum relief (draft regulator) manufacturer's instructions for installation. See figures 14 and 15 for vacuum relief valve.

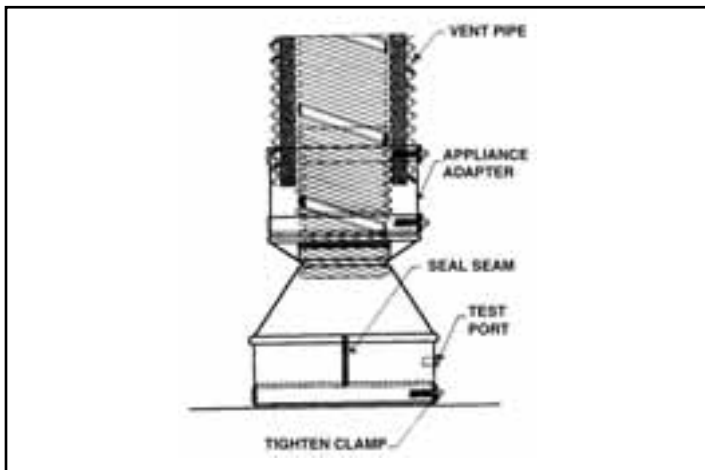

FIGURE 10: Connection to appliance

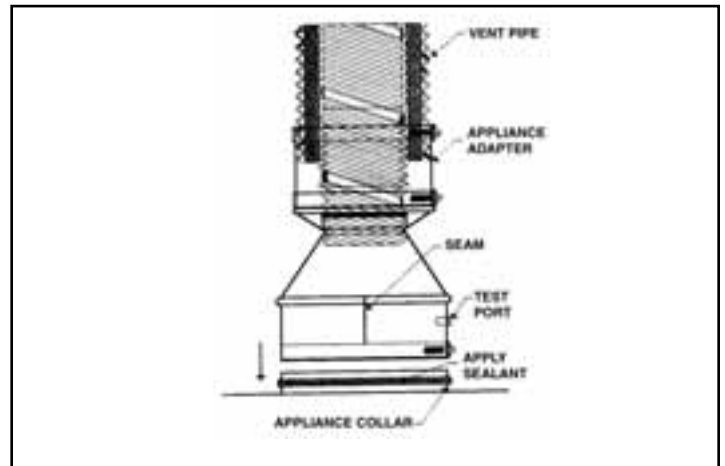

FIGURE 11: Connection to appliance

**Utilize the appliance adapter test port for combustion testing.**

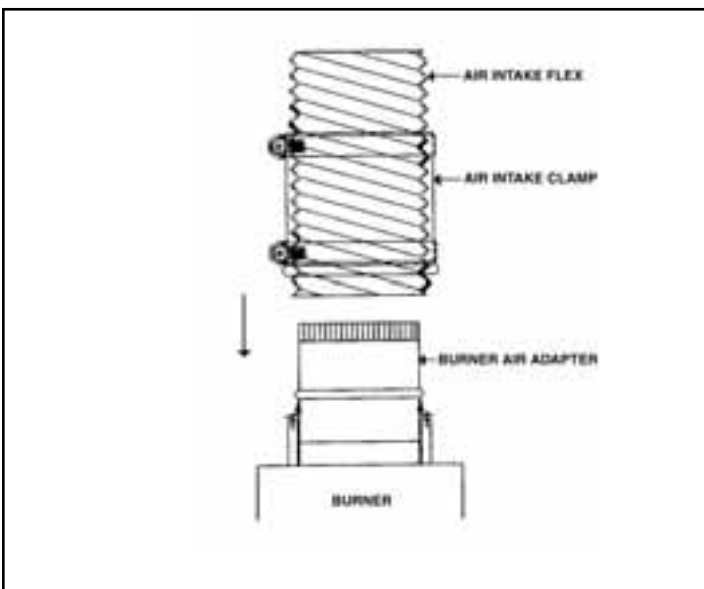

FIGURE 12: Connection to burner

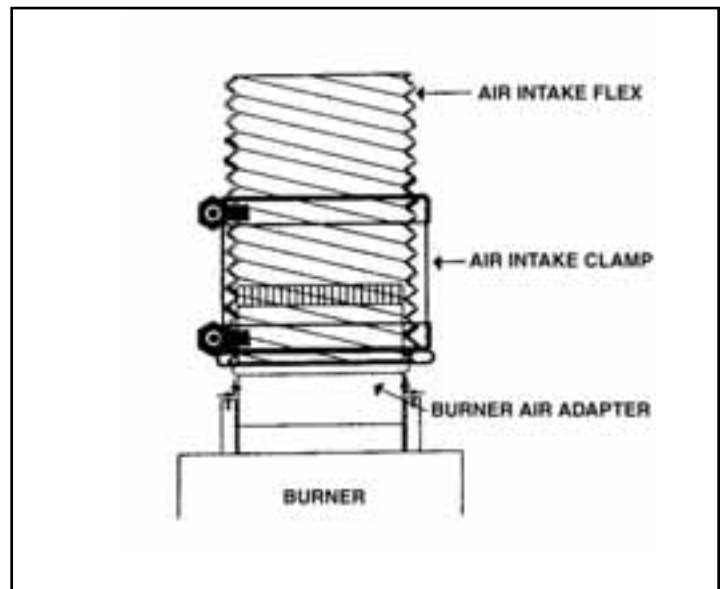

FIGURE 13: Connection to burner

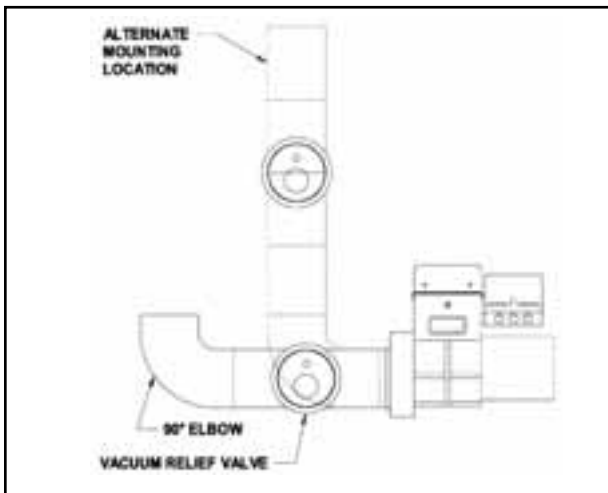

FIGURE 14: Connection of vacuum relief valve

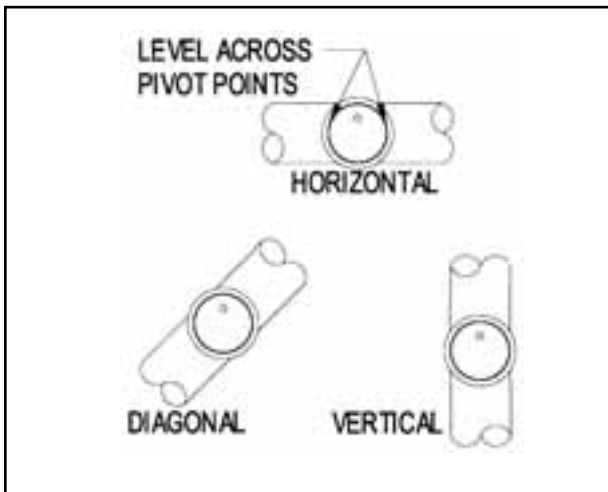

FIGURE 15: Vacuum relief valve

## FLEX-L VENT SYSTEM PART NUMBERS

Item	S/F Part Number	Description	
1	43-2771	Vent terminal (Flex L p/n CFT4)	required
2	43-2785	Kit includes: 5 ft. length vent piping, appliance adapter, terminal adapter and 10 oz. tube silicone (Flex L p/n CFK054-SF)	one required
	43-2786	Kit includes: 10 ft. length vent piping, appliance adapter, terminal adapter and 10 oz. tube silicone (Flex L p/n CFK104-SF)	
	43-2787	Kit includes: 15 ft. length vent piping, appliance adapter, terminal adapter and 10 oz. tube silicone (Flex L p/n CFK154-SF)	
	43-2788	Kit includes: 20 ft. length vent piping, appliance adapter, terminal adapter and 10 oz. tube silicone (Flex L p/n CFK204-SF)	
3	43-2779	Riello burner adapter-air intake (Flex L p/n CFBA34-RL)	one required
4	43-2796	Vacuum relief valve 4" with tee (Field controls p/n 46257100)	required

## Optional vent system parts:

S/F Part Number	Description
43-2793	10 oz. tube silicone
43-2794	3 oz. tube silicone
43-2795	4" Air Intake Clamp

## MAINTENANCE

For the appliance see the installation manual, TRDV-40, for the required maintenance. The vent system must be checked annually by a qualified heating professional. Vent system must be sealed and the intake and exhaust opening clear of any obstructions.

## FIELD CONTROLS VENT SYSTEM PART NUMBERS

Item	S/F P/N	Description	Comment
1	47-0196	EC-16/ TRDV Direct Vent System of: Field Controls FDVS-46 Direct Vent System & Field Controls (P/N 46257100) Vacuum Relief Valve	One required
2	43-2774	Field Controls 3-4" Riello Burner Adapter	One required
3	47-0197 47-0198	Field Controls FOVP-415 (15' of 4" Insultd. Vent Pipe) Field Controls FOVP-410 (10' of 4" Insultd. Vent Pipe)	One required



## FIELD CONTROLS

## FIELD CONTROLS VENT TERMINAL

**Do not install vent terminals on prevailing wind wall side of structure. Moisture and ice may form around terminal. Make sure the surface is in good repair and protected from damage.**

**Slant/Fin model TRDV boilers can be installed on sealed or direct vented systems. They must be ordered from the factory with an approved Direct Vent System. Part numbers for the kits and accessories can be found on page 8 of this manual.**

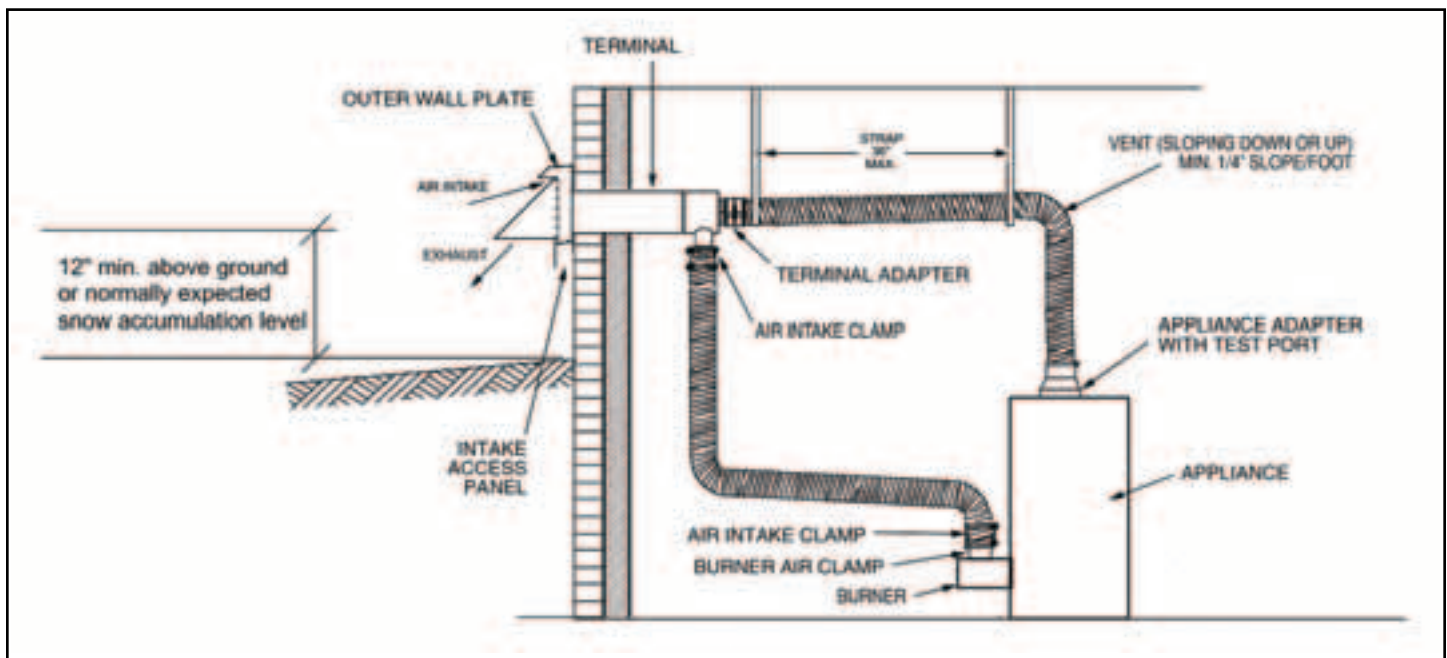

Typical installation. Note: Vacuum relief valve (VRV) not shown. VRV must be located as shown on page 8.

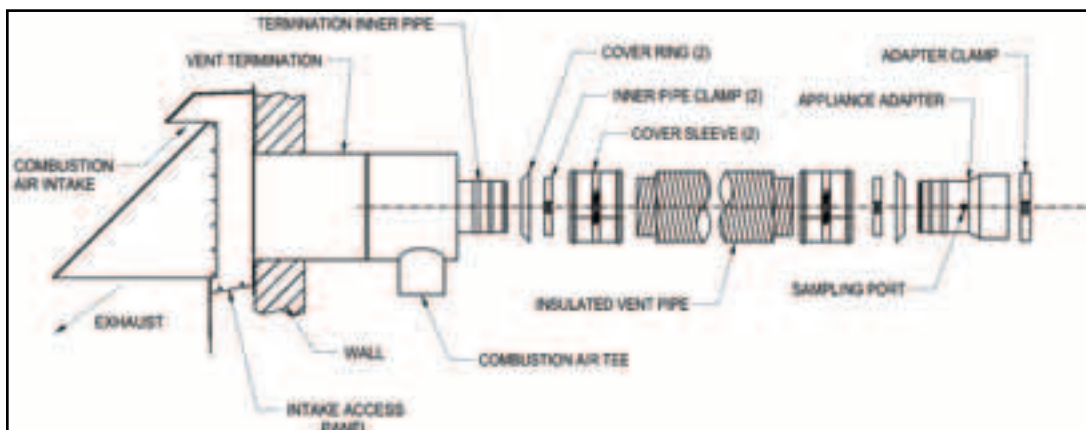

Vent Terminal

## FIELD CONTROLS

### ITEMS INCLUDED IN KIT:

FDVS Direct Vent Termination

\*VRV-4 Vacuum Relief Valve

Backing Plate

Installation Instruction Sheet

\*\*Bagged Hardware

\*\*Cover Ring

\*\*Cover Sleeve

\*\*Appliance Adapter

\*\*Adapter Clamp

\*Not included in some models

\*\*Included with FOVP (Flex Oil Vent Pipe) for some models

### FIELD DIRECT VENT SYSTEM



Model: FDVS

The Field Direct Vent System (FDVS) is a non-powered positive pressure side wall vent termination system for use only with specifically listed oil fired appliances. The system provides an outlet for exhaust gases and an intake for combustion air in a single concentric terminal. The FDVS termination is designed to direct the hot exhaust gases away from the structure using the static pressure generated by a special oil burner. All of the internal parts in contact with the flue gases are made from corrosion resistant 316L stainless steel. The FDVS, with its built-in combustion air tee, allows connecting standard galvanized pipe from the FDVS termination to the air intake of a special oil burner or by use of a Field Controls Airboot, depending on the model of the oil burner.



### **WARNING:**

**This system MUST be installed by a qualified agency in accordance with the manufacturer's installation instructions.** The definition of a qualified agency is: any individual, firm, corporation or company which either in person or through a representative is engaged in, and is responsible for, the installation and operation of oil appliances, who is experienced in such work, familiar with all the precautions required, and has complied with all the requirements of the authority having jurisdiction.



### **WARNING:**

- Read the installation instructions carefully and completely before proceeding with the installation.
- For continued safe operation, the appliance vent system combination is required to be inspected and maintained annually by a qualified agency. Failure to properly maintain the appliance vent system combination can lead to Death, Personal Injury and or Property Damage



### **WARNING:**

1. Safety inspection of a venting system should be performed before and after installing a venting system on an existing or new appliance. Procedures to follow are the latest version of those recommended by the National Fuel Gas Code, ANSI Z223.1, UL-726, NFPA31, CSA B139, CSA B140.0.03 appliance manufacturer's recommendations, or refer to the General Installation Inspection section of this manual.
2. Plan the vent system layout before installation to avoid the possibility of accidental contact with concealed wiring or plumbing inside walls.

FIELD CONTROLS

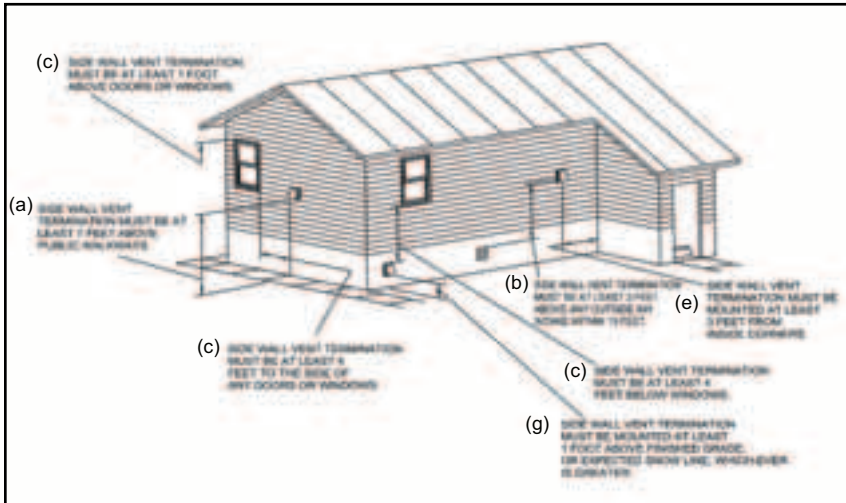

Diagram A

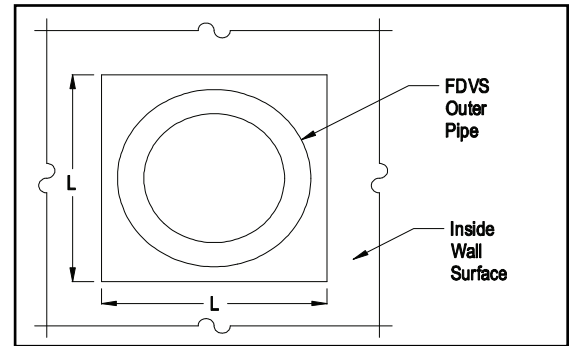

Figure 16. End View

Model	"L"
FDVS-4	7-1/4"

Table 1.

INSTALLATION OF FDVS DIRECT VENT SYSTEM

Installation of the Vent Termination

1. Remove vent system components from box and inspect for damage. If the carton has been crushed or mutilated, check components very carefully for damage. DO NOT install if any damage is apparent.
2. Remove the combustion air tee assembly from the vent termination. Set the tee aside for later use.
3. The location of the vent termination must be installed according to all local codes that are applicable. In the USA according to the latest version of the National Fire Protection Association NFPA-31, National Fuel Gas Code ANSI Z223.1. Where requirements for venting standards differ the most stringent standard shall apply. In Canada according to the latest version of CSA B140 and the CSA B139 Installation Code. Refer to the following requirements or See Diagram A for typical locations.
  - a. The exit termination of mechanical draft systems shall not be less than 7' above grade when located adjacent to public walkways.
  - b. A venting system shall terminate at least 3' above any forced air inlet located within 10'.
  - c. The venting system of other than a direct vent appliance shall terminate at least 4' below, 4' horizontally from, or 1' above any door, window or gravity air inlet into the building.
  - e. The vent termination point shall not be installed closer than 3' from an inside corner of an L-shaped structure.
  - f. The vent termination should not be mounted directly above, or within 3' horizontally from an oil tank vent or gas meter.
  - g. The bottom of the vent terminal shall be located at least 12" above finished grade or expected snow line, whichever is greater.
4. After determining the location of the venting system termination (See Diagram A), cut a hole in the wall sized according to "L" dimension in Table 1. (See Figure 16)
5. Seal the back side of the base plate around the outer pipe of the vent termination with a bead of high temperature silicone sealant. (See Figure 17) Mount the vent termination through the wall, keeping the outer pipe centered in the hole. (See Figure 16) Fasten the vent termination to the outside wall with appropriate fasteners. Seal the edges

- of the vent termination base plate to the wall with a high-temperature silicone sealant.
6. Mount the backing plate over the outer pipe. Fasten the backing plate to the inside wall with appropriate fasteners. (See Figure 17) DO NOT BLOCK the intake or exhaust openings, or the intake access panel on the vent termination body. Wood or vinyl siding should be cut so that the unit mounts directly on the wallboard to provide a stable support. If the siding is greater than 1/2" thick use a spacer plate or board behind the vent termination mounting plate. (See Figure 17)

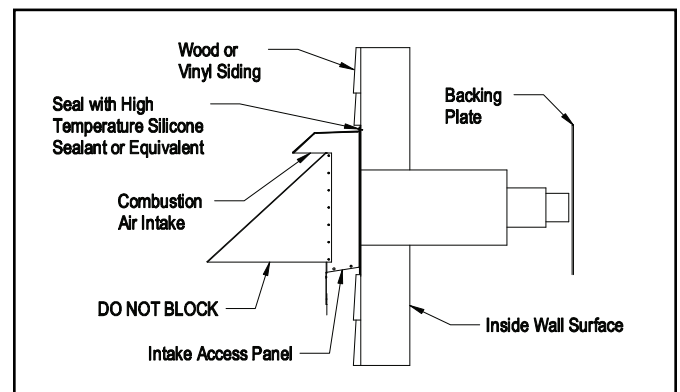

Figure 17. Side View

## FIELD CONTROLS

### INSTALLATION OF THE VENT TERMINATION COMBUSTION AIR TEE

1. Assemble the combustion air tee assembly body to the vent termination outer pipe, and rotate to the desired position. Attach the tee assembly body to the vent termination outer pipe with at least 3 sheet metal screws evenly spaced apart (not included).
2. After completing assembly of the vent pipe to the termination inner pipe (Fig. 19), apply the supplied high temperature sealant to the cover pan around the inner pipe, around the joint between the collar and the Tee assembly, and seal or tape the joint from the FDVS Termination to the Tee assembly.

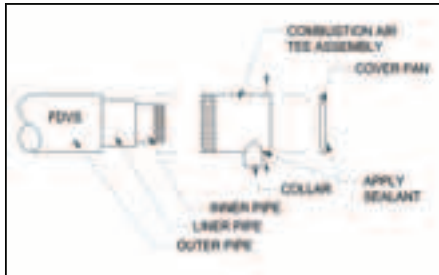

Figure 18 - Top View

**NOTE:** The tee may be rotated into any position so that the collar is in a convenient orientation.

**CLEARANCE TO COMBUSTIBLES:** FDVS Termination: 0", FOVP Flexible Oil Vent Pipe: 1". These clearances are to be maintained unless superseded by National and/or local codes (see Step 3).

### CONNECTING THE VENT PIPE FROM THE FDVS TO THE APPLIANCE

1. The venting system should be installed and supported in accordance with the latest version in the USA of the National Fuel Gas Code ANSI Z223.1, UL-726, National Fire Protection Association NFPA31, and in Canada CSA B140, CSA B139 Installation Code or in accordance with any other local codes or the authority having jurisdiction. Where requirements for venting differ the most stringent standard requirements shall apply. A vent pipe connector, designed for positive pressure venting, shall be supported for the design and weight of the material employed, to maintain clearances, prevent physical damage and separation of joints. All joints **MUST** be sealed, for positive vent pressure, to prevent flue gas leakage into the structure.
2. Route the vent pipe from the appliance to the vent termination using the minimum number of bends as possible. The last horizontal section of the vent pipe should have a slight downward slope from the appliance to the vent termination. For clearances to combustible materials and other installation requirements, refer to the National Fuel Gas Code ANSI Z223.1, UL-726, NFPA31, CSA B140, CSA B139 and/or any applicable local codes.
3. The maximum length of vent pipe run for the EC-10DV boiler series is 15 feet. The minimum diameter of the approved vent pipe is 4" for the EC-10DV boiler series. Use a reducer or increaser, if necessary, at the vent termination to connect the vent pipe.
4. Support the Flexible Oil Vent Pipe (FOVP) at regular intervals of maximum 36" spacing with appropriate strapping or hangers, per National and local code requirements. Do not install screws into or otherwise penetrate any part of the vent pipe under any circumstances.

### CONNECTING THE COMBUSTION AIR INTAKE PIPE FROM THE FDVS TO THE APPLIANCE

1. Use 4" galvanized steel pipe or stainless steel pipe from the FDVS terminal combustion air tee collar to the appliance oil burner combustion air inlet (or Air boot, if applicable.) Use a reducer or increaser, if necessary at the burner combustion air inlet to connect the combustion air intake pipe.
2. The VRV should be installed close to the air inlet of the burner, see fig. 14 on page 8.

### GENERAL INSTALLATION INSPECTION

Recommended procedures for safety inspection of an appliance should be in accordance with the latest version of the National Fuel Gas Code ANSI Z 223.1, UL 726, and the National Fire Protection Association NFPA 31 in the USA, CSA B140 and CSA B139 Installation Code in Canada. The following procedure will help evaluate the venting system. It is intended as a guide to aid in determining that the venting system is properly installed and is in a safe condition for continuous use. This procedure should be recognized as a generalized procedure which cannot anticipate all situations. Accordingly, in some cases, deviation from this procedure may be necessary to determine safe operation of the equipment. If it is determined that a condition exists which could result in unsafe operation, the appliance should be shut off and the owner advised of the unsafe condition. Corrections must be made before the appliance is put into continuous operation. The following steps should be followed in making a safety inspection.

1. Visually inspect the venting system for proper size and determine that there is no flue gas spillage, blockage, restriction, leakage, corrosion, or other deficiency which could cause an unsafe operation.
2. Place in operation the appliance being inspected. Follow the lighting instructions and adjust thermostat so appliance will operate continuously.
3. Determine that the burner is operating properly and that the burner ignition operates satisfactorily by interrupting and reestablishing the electrical power of the appliance in any convenient manner. Test the burner safety device to determine if it is operating properly by disconnecting the flame safety circuit.
4. Test for spillage at the burner inlet air location around the VRV after 5 minutes of operation. Use a draft gauge, flame of a match or candle, or smoke from a cigarette, cigar or pipe. Shut off appliance thermostat and check for spillage around the VRV. If a flow reversal is noticed, house depressurization is occurring and make up air is required.

### MAINTENANCE

Inspect all vent connections annually for looseness, evidence of corrosion, or flue gas leakage. Replace, seal, or tighten pipe connections if necessary. As part of the yearly maintenance schedule, remove the Intake Access Panel on the exterior of the FDVS vent termination (See Figure 17) and remove any debris or foreign material. Be sure to properly replace the panel.

## FIELD CONTROLS

REFER TO PAGE 8 FOR VACUUM RELIEF VALVE CONNECTIONS AND VENT SYSTEM PART NUMBERS

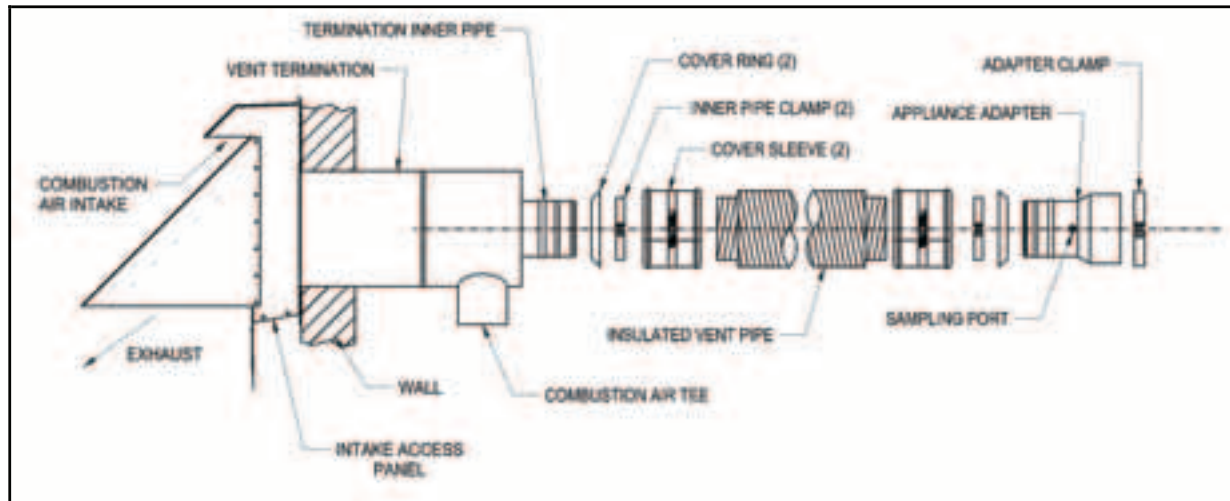

Figure 19

**APPLIANCE ADAPTER INSTALLATION:**

1. Apply a bead of sealant to appliance collar approx. 1" from end of collar (Figure 20).
2. Remove all oil and grease from the inside of the appliance adapter, and apply a bead of sealant to inside of adapter ?" from end (Figure 20).
3. With a twisting motion, assemble the appliance adapter onto the appliance collar.
4. Using a mallet and block of wood, drive the adapter onto the appliance collar, using care to avoid damaging the appliance collar or the adapter (Figure 21).
5. Assemble adapter clamp halves using the supplied 5/16" bolts and square nuts, and install the appliance clamp onto the adapter and tighten securely (Figure 20).
6. Install the supplied self-drilling, self-tapping anchoring screws through the 4 holes in the appliance clamp into the appliance collar (Figure 21). No pilot hole is required.
7. Apply sealant to the end of the adapter and anchoring screws. (Figure 21).
8. After testing and burner adjustments have been made, apply sealant to the supplied 3/8" sampling port plug screw and install the screw in the sampling port (Figure 21).
9. Maintain the following clearances to combustibles. If the appliance collar is within 18" of combustible material, wrap minimum 1-1/2" ceramic insulation (installer-supplied) around the exposed portion of the termination inner pipe and appliance adapter (Figure 25).

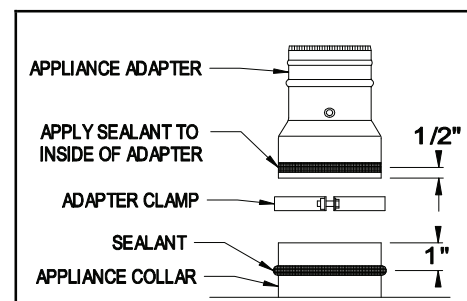

Figure 20

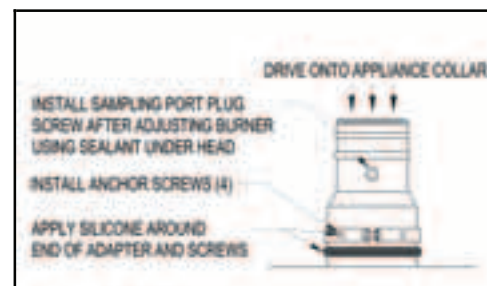

Figure 21

## FIELD CONTROLS

## REFER TO PAGE 8 FOR VACUUM RELIEF VALVE CONNECTIONS AND VENT SYSTEM PART NUMBERS

**JOINT ASSEMBLY: VENT PIPE TO TERMINATION AND APPLIANCE ADAPTER**

If necessary, the vent pipe may be cut to length with a hacksaw or cut off saw.

**CAUTION:** Use safety glasses and other appropriate safety gear.

1. Pull outer vent pipe back 1"-2" from inner vent pipe end and remove insulation (Figure 22).
2. Slide Cover Sleeve onto end of vent pipe a few inches back from end of outer vent pipe (Figure 22).
3. Slide Cover Ring over stop bead on termination inner pipe or appliance adapter (Figure 22).
4. Assemble inner pipe clamp halves using the supplied  $\frac{1}{4}$ " bolts and square nuts, and position inner pipe clamp  $\frac{1}{4}$ " from end of inner pipe (Figure 22).
5. Remove all oil and grease from end of termination inner pipe or appliance adapter, and apply a bead of sealant to between the stop bead and retainer bead (Figure 23).
6. Apply a thick bead of sealant to inside of inner vent pipe  $\frac{1}{2}$ " from the end of pipe, working the sealant into the corrugations (Figure 23).
7. Push the inner vent pipe onto the termination inner pipe or appliance adapter all the way up to the stop bead.
8. Tighten the inner pipe clamp bolts until both clamp halves are within  $\frac{1}{8}$ " of each other at each end (Figure 24).
9. Slide the cover sleeve and cover ring together to engage the ring in the groove of the sleeve, and tighten the cover sleeve clamp (Figure 25).
10. To maintain 1" clearance to combustibles, wrap minimum 1-1/2" thick ceramic insulation (installer-supplied) around the exposed portion of the termination inner pipe (Figure 25), and secure with foil tape (installer supplied).

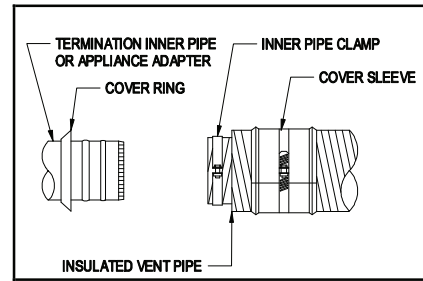

Figure 22

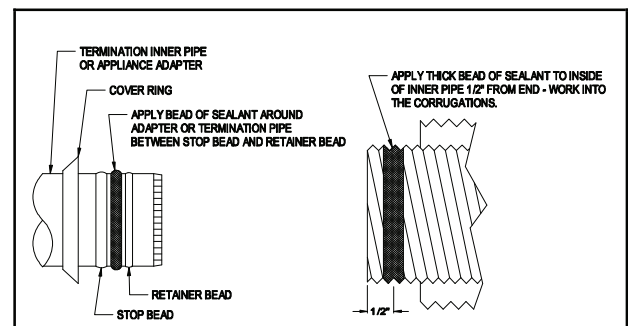

Figure 23

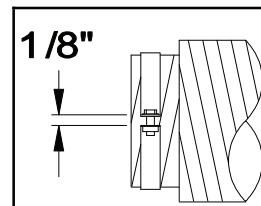

Figure 24

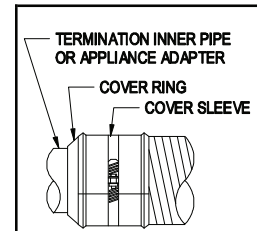

Figure 25





---

**SLANT/FIN CORPORATION, Greenvale, N.Y. 11548 • Phone: (516) 484-2600**

FAX: (516) 484-5921 • Canada: *Slant/Fin LTD/LTEE, Mississauga, Ontario*

[www.slantfin.com](http://www.slantfin.com)