



CLICK ANYWHERE on THIS PAGE to RETURN TO CONDENSATE PUMPS at [InspectApedia.com](https://www.inspectapedia.com)

UNIVERSAL CONDENSATE PUMP INSTRUCTIONS

When replacing any part on this appliance, use only spare parts that you can be assured conform to the safety and performance specification that we require. Do not use reconditioned or copy parts that have not been clearly authorised by Ideal Heating. For the very latest copy of literature for specification and maintenance practices visit our website [idealheating.com](https://www.idealheating.com) where you can download the relevant information in PDF format.

December 2020
UIN 202303 A05



1 PACK CONTENTS

- | | |
|---------------------------|----------------------------|
| A Condensate Pump - 1 off | E Hose 6m - 1 off |
| B Pipe Adaptor - 1 off | F Mains Cable - 1 off |
| C Wall Plugs - 2 off | G Alarm Cable - 1 off |
| D Wood Screws - 2 off | H Barbed Connector - 1 off |

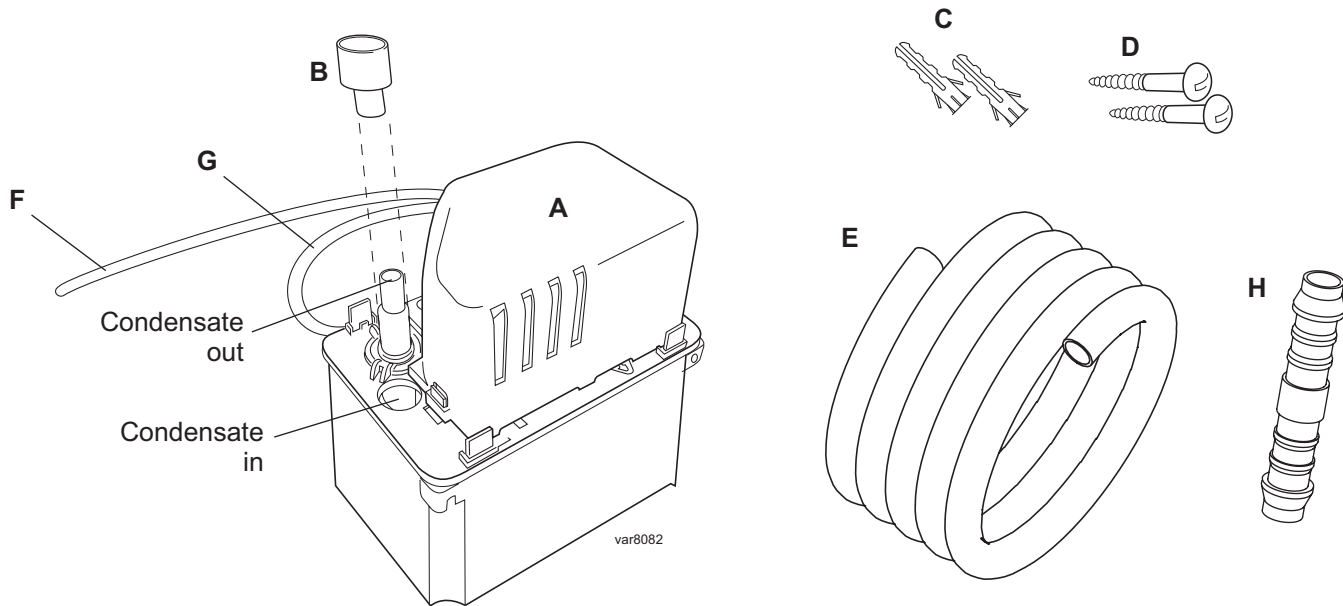

TECHNICAL INFORMATION

- Maximum flow rate 440 litres/hour
- Electrical supply..... 230V AC / 50-60 Hz 0.8amps
- Alarm contact..... NC 4 amps resistive
- Overheat protection 130°C
- Tank Capacity 2.0 Litres
- Length..... 195mm
- Width 130mm
- Height 170mm
- Maximum vertical head - 4.5m
- Maximum horizontal length - 30m

INTRODUCTION

The condensate pump is designed to collect and remove condensate and can be used with high efficiency condensing boilers.

The condensate drain pipe from the boiler is connected into the pump using 21.5mm overflow pipe and collected in the sump. Once the sump capacity of 2.0 litres is achieved the pump operates to discharge the condensate via the outlet pipework to the discharge point.

The pump is fitted with 2 float switches which operate on the depth of condensate within the sump i.e. on reaching a depth of 43mm the first float switch operates to energise the pump to discharge the condensate and the pump shuts down when the level drops to 27mm.

Should a fault occur within the condensate outlet pipe, e.g. a blockage, the pump will shut off the boiler when the condensate level reaches 67mm in the sump, via the second float switch (provided the alarm wiring has been connected to the boiler terminal strip - see wiring information).

NOTE TO THE INSTALLER: LEAVE THESE INSTRUCTIONS ADJACENT TO THE GAS METER

2 INSTALLING THE PUMP

To ease installation, the tank on the pump is reversible i.e. this can be fitted to accept the condensate drain pipework from the boiler to either the left or right hand side.

Condensate Inlet on left

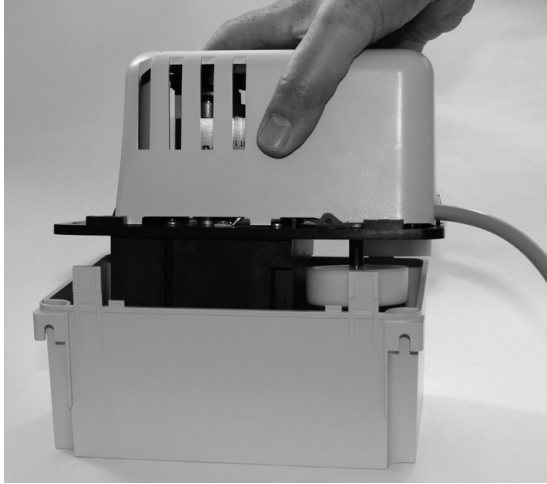

1. Consideration should also be taken of the siting of the pump to prevent noise emissions and vibrations.
2. To ensure sufficient ventilation to the motor the area around the pump should be left unobstructed.
3. The pump should not be installed where ambient temperatures may fall below freezing or in areas of a very high humidity. The pump must be fitted in a dry area and away from where it could be splashed with water. (The IP rating of the pump is **IP20**).
4. The pump must be installed horizontally where the condensate drain pipe from the boiler can enter into the 'condensate in' collection pipe on the pump, using 21.5mm plastic overflow pipe.

As the condensate from the boiler is gravity fed into the condensate pump kit it is essential the pump is sited lower than the boiler.

5. If required, the pump kit can be wall mounted as follows:
 - a. Mark two holes to suit wall plugs provided 176.5mm horizontally apart to coincide with location mounting lugs provided on side of condensate pump unit. Ensure adequate clearance for pump body and connecting pipework around mounting location chosen before drilling holes. Drill holes accordingly.

Condensate Inlet on right

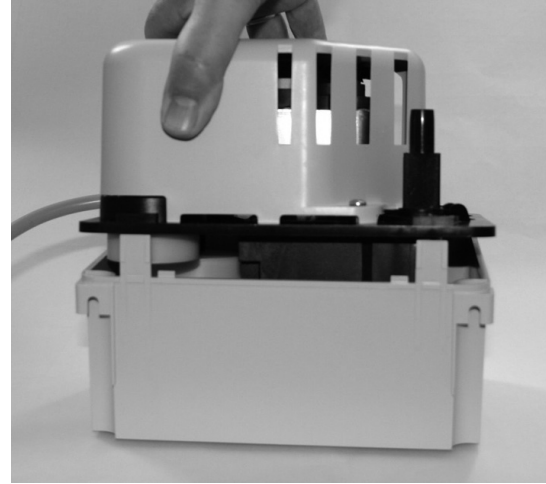

- b. Insert wall plugs and screws, leaving 3mm protruding on the screws.
 - c. Mount pump onto screws using the fixed slot holes on the casing. See Frame 3.
6. The pump discharge connection should be made using the pipe adaptor supplied in the kit, which is a push-fit on to the check valve. This allows standard 21.5mm plastic overflow pipe to be used up to the final discharge point. Alternatively the clear plastic pipe, barbed adaptor and pipe adaptor provided can be used to allow standard 21.5mm plastic overflow pipe to discharge the condensate. (See *condensate pipe termination configurations*).
 7. Wiring of the pump should be made following the relevant wiring diagram. See Frame 7.

ATTENTION.

When fitting the clear plastic pipe provided for condensate outlet, ensure installation route is away from any hot surfaces.

3 OPERATING THE PUMP

Before operating the pump, the float protection strip should be pulled out to free off the float switch.

To check operation pour water into the sump until the pump operates (first float switch makes contacts) and then stops once the level of the water falls.

It is possible to check the alarm contacts by continuing to pour water into the sump, until the second float switch lifts and breaks the contacts to the alarm wiring thus switching off the power supply to the boiler. Check switch operation with a suitable electrical test meter.

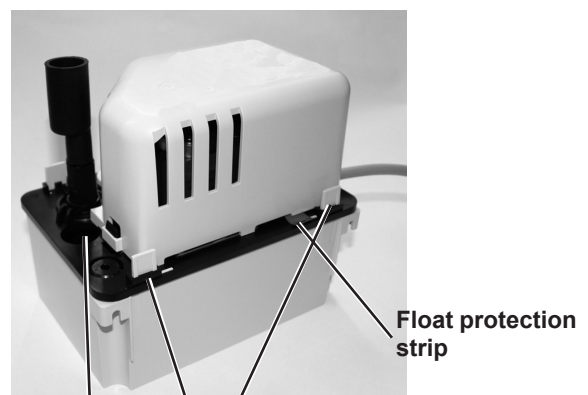

Pour in water

Fixed Slot holes

Float protection strip

4 CONDENSATE RUNS

NOTE.

As the condensate from the boiler is gravity fed into the condensate pump it is essential that the pump is sited lower than the boiler.

For termination options see Frames 5 and 6.

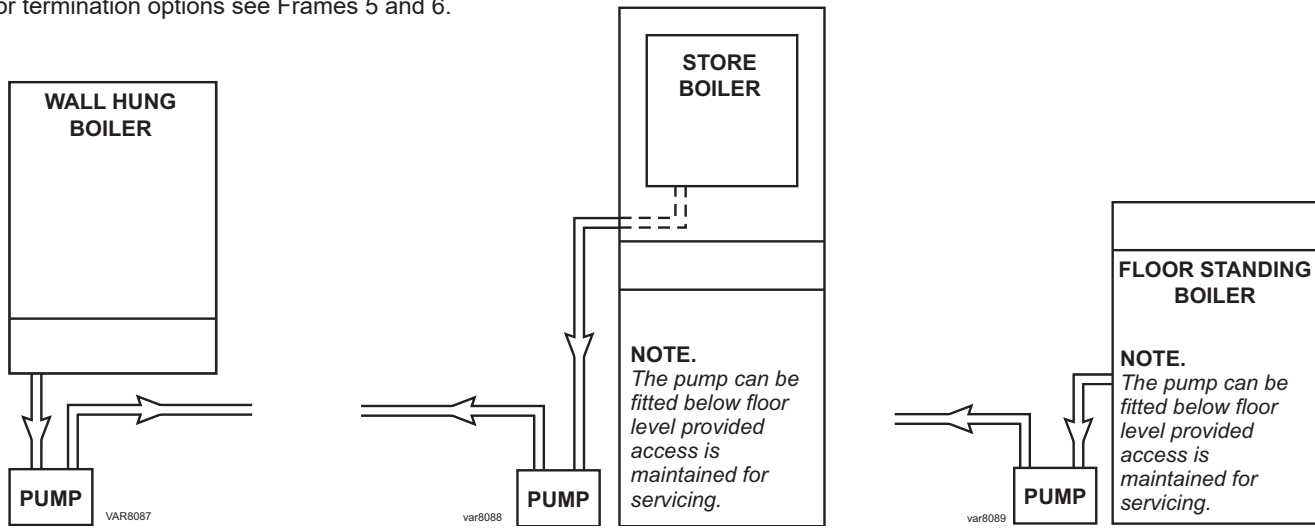

5 CONDENSATE PIPE TERMINATION CONFIGURATIONS

Note. ALL EXTERNAL PIPE RUNS MUST BE INSULATED

1. INTERNAL TO SINK WASTE UPSTREAM OF SINK WASTE TRAP

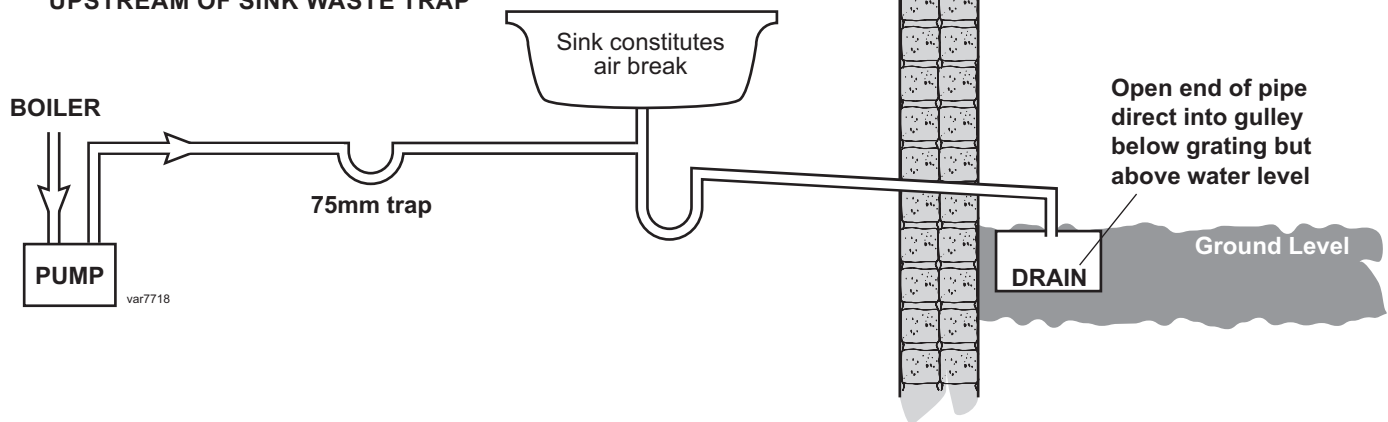

2. INTERNAL TO SINK WASTE DOWNSTREAM OF SINK WASTE TRAP (PREFERRED METHOD)

* If drain termination is to soil stack, a 75mm trap will be required

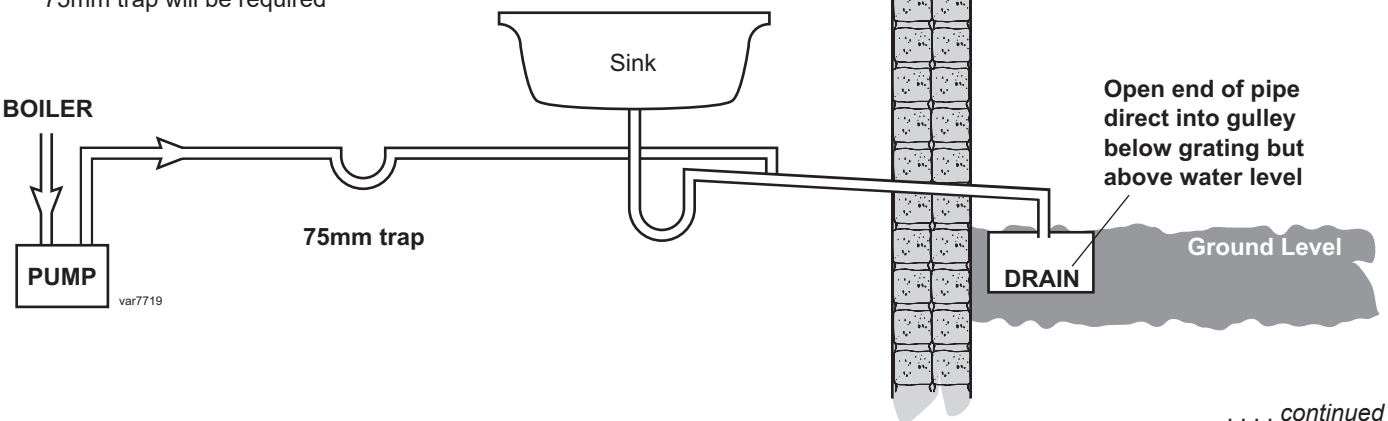

... continued

6 CONDENSATE PIPE TERMINATION CONFIGURATIONS . . . continued

3. INTERNAL CONNECTION TO SOIL AND VENT STACK

* Make connection to soil and vent pipe using a solvent welded saddle

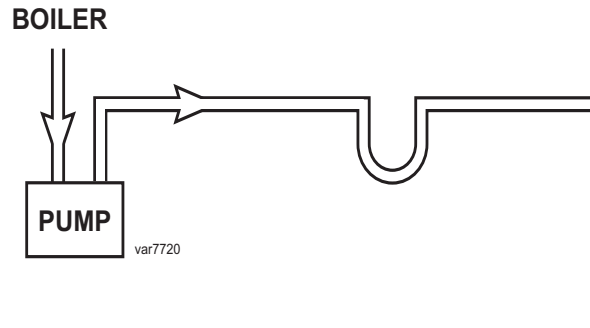
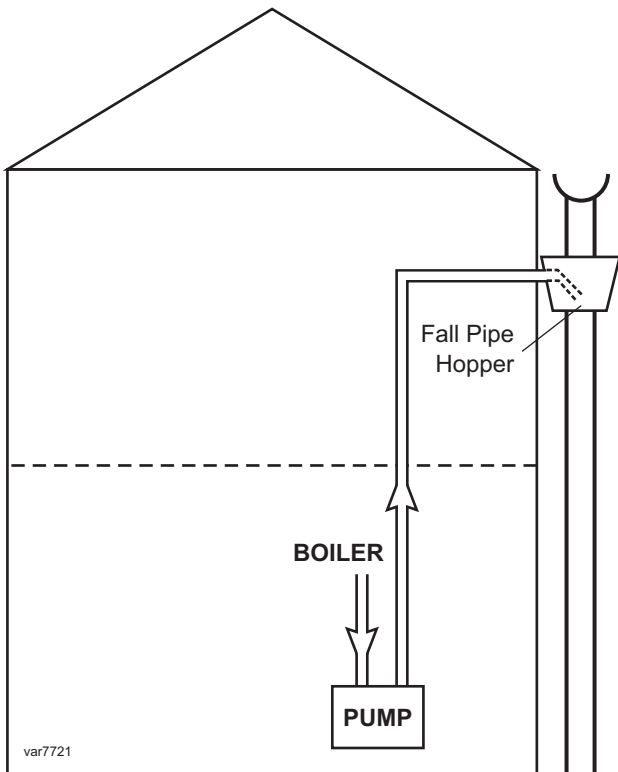

4. TERMINATION INTO FALL PIPE HOPPER

* Condensate pipe must terminate in the hopper - IT MUST NOT be connected into the fall pipe

5. TERMINATION TO SOAK AWAY

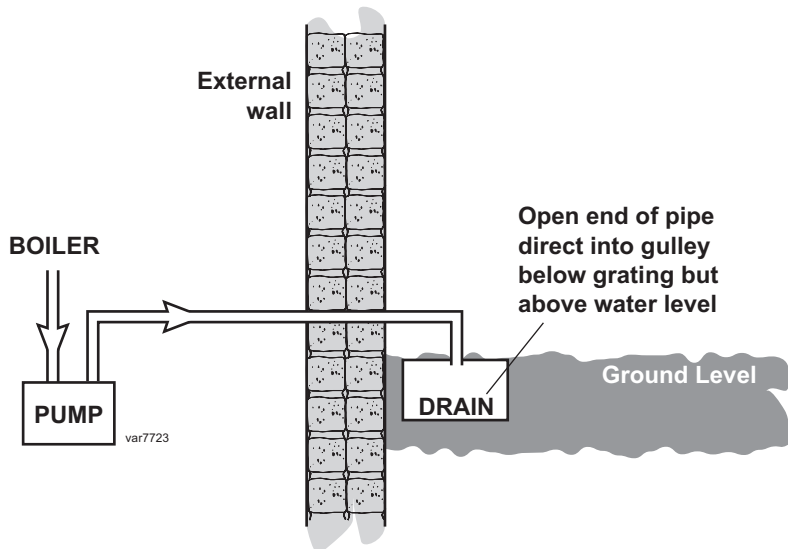
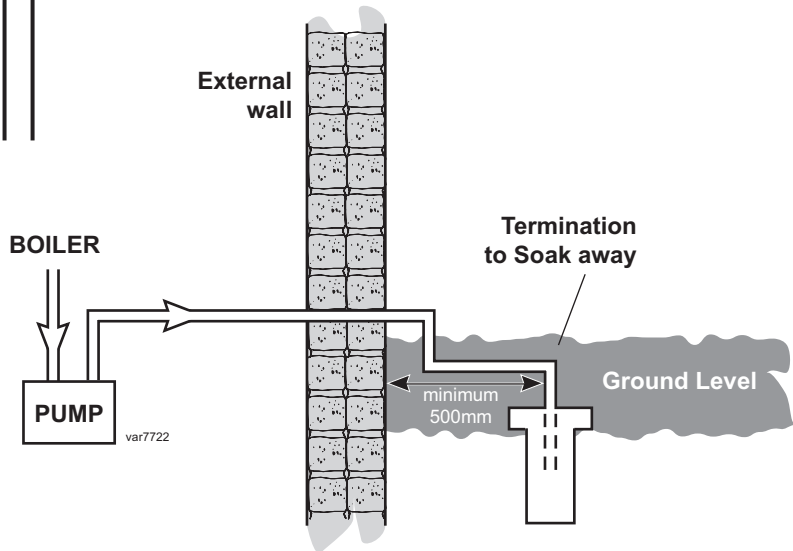

6. TERMINATION TO DRAIN / GULLEY

7 WIRING

Note.

1. The wiring for the alarm contacts.
2. Choose the wiring diagram from those below (A-D) which matches that of the appliance. If in doubt contact the appliance manufacturer.
3. Wiring diagrams provided depict the additional wiring needed for the inclusion of the condensate pump. This scheme may be incorporated into the existing wiring centre junction box, fused spur etc. incorporated in the heating system as appropriate.

A - Heating Only - No Permanent Live

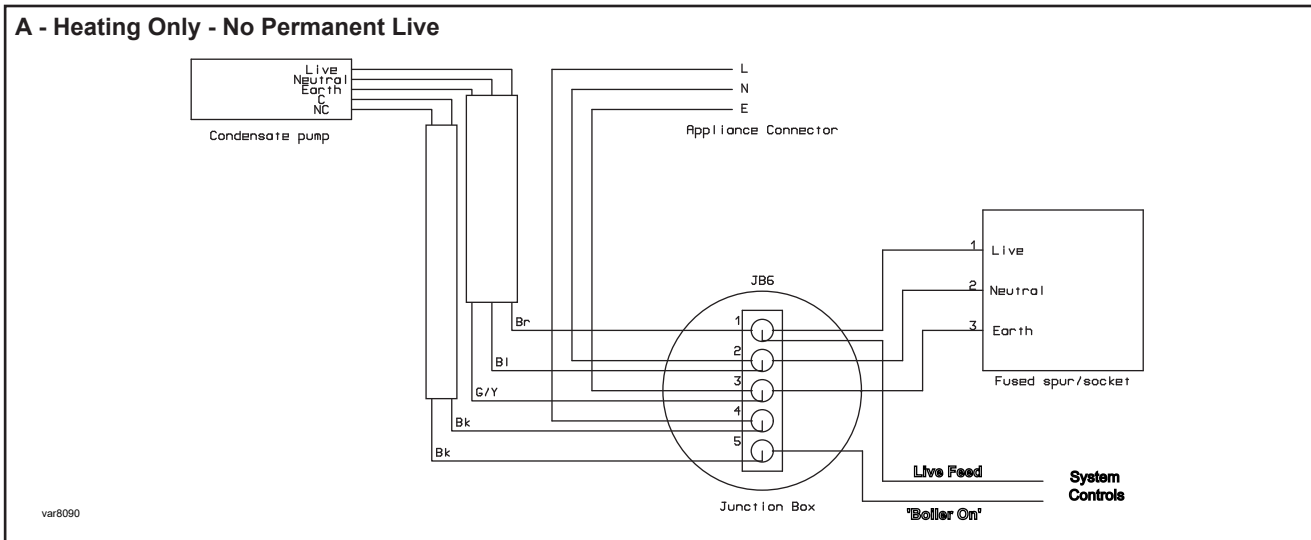

B - Heating Only - With Permanent Live

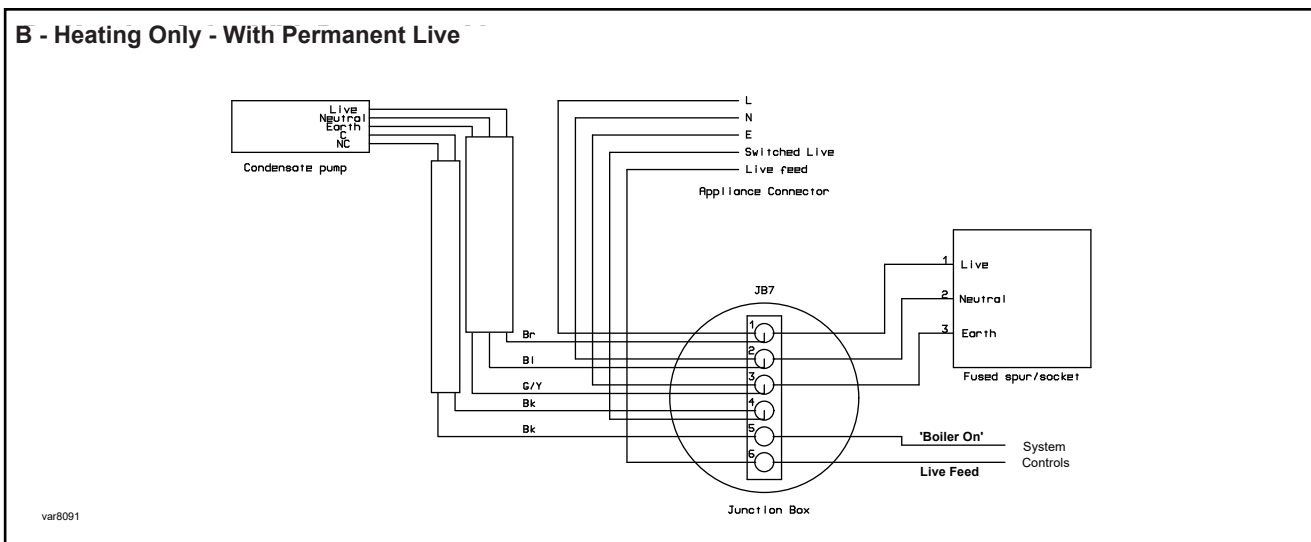

C - Combi Appliance

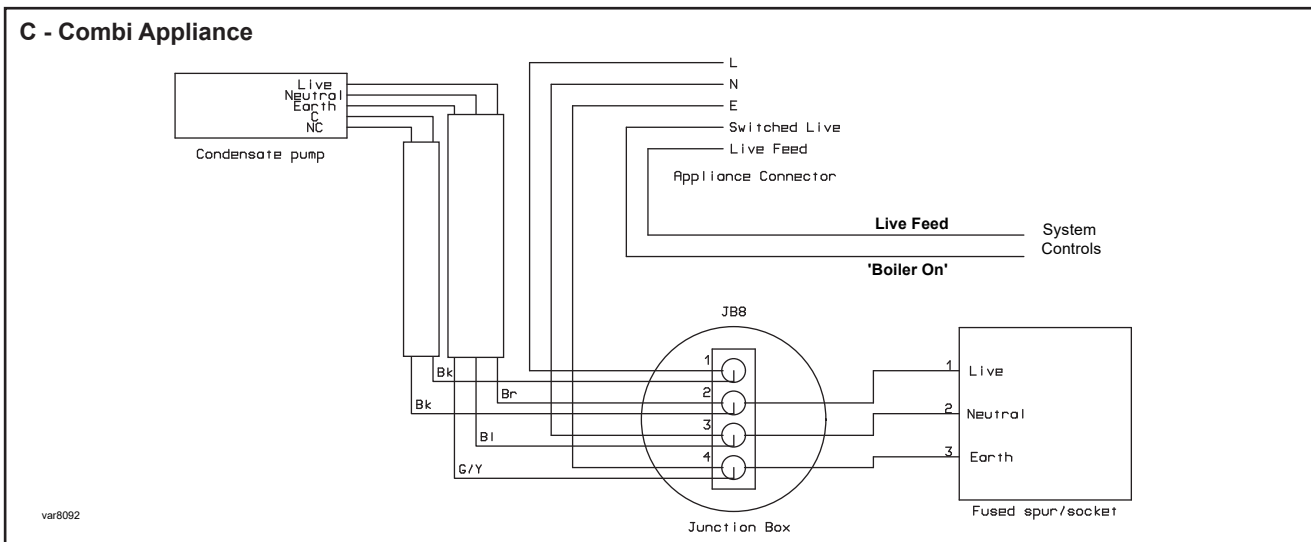

7 WIRING - Continued

D - Imax Xtra 2 Appliance

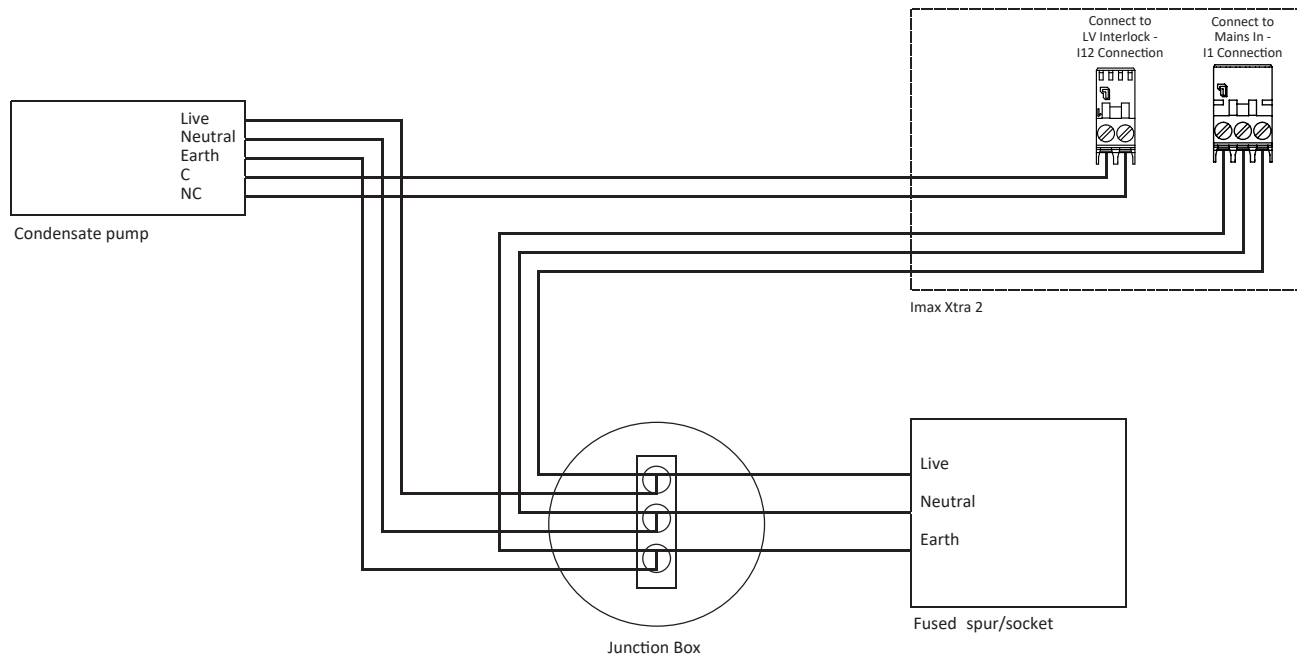

8 MAINTENANCE AND SERVICING

The inside of the pump kit should be cleaned regularly at every annual service of the appliance.

Note. Before any maintenance the pump must be isolated from the power supply. When disconnecting the inlet and outlet pipe work from the pump make provision to capture any condensate which may be still contained within the pipe work

1. Remove the reservoir by disengaging the four plastic retaining pegs and lift the pump off. Clean the reservoir as necessary.
2. Ensure the floats remain clean and free to move.
3. Turn the check valve anti-clockwise to unlock then remove and clean.
4. Re-assemble in reverse order.
5. Re-establish power supply and carry out checks. See Frame 2.

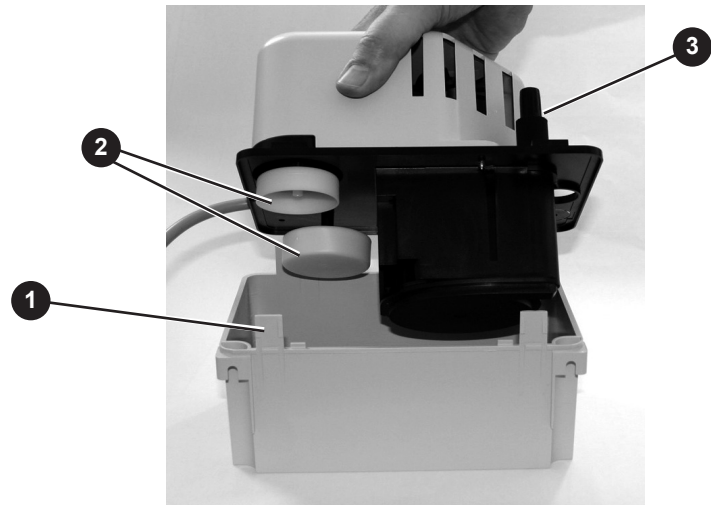



FM 59915
Manufactured under an
ISO 9001 registered quality
management system

Technical Training

Our Expert Academy offer a range of training options designed and delivered by our experts in Heating.
For details please contact:
expert-academy.co.uk

Ideal Boilers Ltd., pursues a policy of continuing improvement in the design and performance of its products.
The right is therefore reserved to vary specification without notice.

Ideal is a trademark of Ideal Boilers.

Registered Office

Ideal Boilers Ltd., National Avenue, Hull, East Yorkshire, HU5 4JB

Tel 01482 492251 Fax 01482 448858

Registration No. London 322 137

Ideal Commercial Technical Helpline: 01482 498376

Ideal Parts: 01482 498665

idealheating.com

ideal
HEATING