



Air-Cooled Series R™ Rotary Liquid Chiller

Model RTAA
70 to 125 Tons

Built for the Industrial and Commercial Markets





Features and Benefits

You...

Like its chillers, Trane wants its relationships with customers to last. Trane is interested in maintaining long term, loyal relationships. This perspective means the point in time that a customer purchases a chiller is the beginning of a relationship, not the end. Your business is important, but your satisfaction is paramount.

Designed by Customers...

Trane's RTAA 70-125 was designed with the end user's requirements in mind. Reliability, efficiency, sound, and physical size were primary design concerns in expanding the RTAA product line down to 70 tons. The result is a reliable chiller that will help you achieve your bottom line goals.



Contents

Features and Benefits	2
Model Number Description	13
General Data	14
Selection Procedure	15
Application Considerations	16
Performance Adjustment Factors	20
Performance Data	22
Electrical Data	29
Jobsite Connections	30
Controls	32
Dimensional Data	40
Weights	41
Options	42
Typical Wiring Diagrams	43
Features Summary	45
Mechanical Specifications	46



The standard ARI rating condition (54/44°F and 95°F) and IPLV are ARI certified. All other ratings, including the following, are outside the scope of the certification program and are excluded:

- Glycol.
- 50 Hz.
- Remote evaporator models.



Water Chiller Systems Business Unit



Features and Benefits

Improvements

The RTAA 70-125 offers the same high reliability of its larger predecessor coupled with lowered sound levels, increased energy efficiency, and reduced physical footprint, all due to its advanced design, low speed/direct drive compressor and proven Series R™ performance.

Some of the major advantages of the Model RTAA 70-125 vs its larger predecessor are:

- Higher energy efficiency
- Lower sound levels
- Smaller physical footprint

The Series R™ Model RTAA 70-125 is an industrial grade design built for both the industrial and commercial markets. It is ideal for schools, hospitals, retailers, office buildings, Internet service providers and industrials.

ASHRAE Standard 90.1 and RTAA 70-125 World Class Energy Efficiency...

The importance of energy efficiency cannot be understated. Fortunately, ASHRAE has created a guideline emphasizing its importance.

Nonetheless, energy is often dismissed as an operational cost over which the owner has little control. That perception results in missed opportunities for energy efficiency, reduced utility bills, and higher profits. Lower utility bills directly affect profitability. Every dollar saved in energy goes directly to the bottom line. Trane's RTAA 70-125 is one way to maximize your profits.

ASHRAE Standard 90.1 & Executive Order

- New technology applied to the design, controls, and manufacturing have created superior efficiency levels in the RTAA 70-125 that are unmatched in the industry. All Trane air-cooled chillers meet the new efficiency levels mandated by ASHRAE Standard 90.1. This new standard requires higher efficiencies than past technologies can deliver. The US Federal Government has adopted standard 90.1 and, in some cases, requires even higher efficiencies. Federal Executive Order mandates energy consuming devices procured must be in the top 25% of their class or

be at least 10% better than any product standard for that product. In the case of chillers, that product standard is ASHRAE 90.1. Trane's RTAA 70-125 meets and exceeds the efficiency requirements of 90.1, with some units meeting the "stretch goals" of Executive Order.

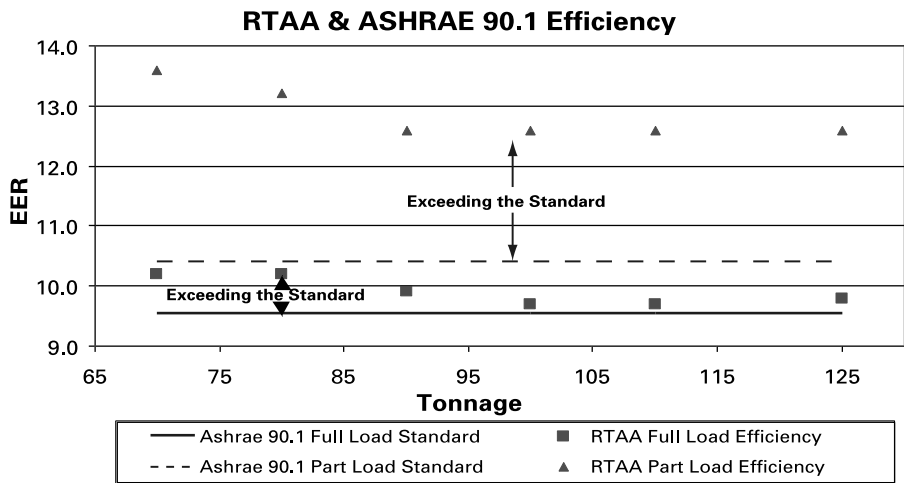

Risk. The US Federal Government has adopted ASHRAE 90.1, and it's expected to be adopted domestically, if not globally, in the future. Domestic acceptance has already begun. Make sure that your chillers as well as your entire HVAC system complies, or you may be caught retrofitting your project with new equipment and paying extra design dollars if the code is adopted during construction.

Precise Capacity Control. Trane's patented unloading system allows the compressor to modulate infinitely and exactly match building loads. At the same time chilled water temperatures will be maintained within +/- 1/2°F of

setpoint, potentially eliminating the need for external considerations to maintain temperatures. Reciprocating and screw chillers with stepped capacity control do well to maintain chilled water temperatures within 2°F of setpoint. Stepped control also results in overcooling or undercooling your space because rarely does the capacity of the machine match the building load. The result can be 10% higher energy bills. Trane's RTAA optimizes the part load performance of your machine for energy efficiency, precise temperature control for all modes of operation, and your personal comfort regardless of changing conditions.

Features and Benefits

Excellent Reliability

A building environment is expected to be comfortable. When it is, no one says a word. If it's not... that's a different story. The same is true with chillers. No one ever talks about chillers, yet alone compressors, until they fail, and tenets are uncomfortable and productivity is lost. Trane's helical rotary compressors have a **first year reliability rate of over 99%**, which means our chillers stay running when you need them.

Screw compressors were designed to replace the inherent design flaws of a reciprocating compressor. Trane's helical rotary compressor has successfully achieved this goal, proven by the over 99% reliability rating of our compressor in the first year of operation. A good design like Trane's should maintain this level of reliability for several years of chiller operation. Not all screw compressors maintain a high reliability and Trane is the only manufacturer that will publish a reliability number. The point is to make sure that you are getting a reliable screw chiller design so that you don't end up with the downtime and lost earnings that the industry is trying to



avoid by getting away from reciprocating technology.

Fewer moving parts. Trane's helical rotary compressors have only two major rotating parts: the male and female rotor. A reciprocating compressor can have more than 15 times that number of critical parts. Multiples of pistons, valves, crankshafts, and connecting rods in a reciprocating unit all represent different failure paths for the compressor. In fact, reciprocating compressors can easily have a failure rate four times that of a helical rotor. Combine this with two to three reciprocating compressors for each helical rotary compressor on chillers of equal tonnage, and statistics tell you it's

a matter of time before you lose a reciprocating compressor.

Robust parts. Helical rotary compressors are precisely machined using state of the art processes from solid metal bar stock. Tolerances are maintained within a micron or less than a tenth of the diameter of a human hair. The resulting compressor is a robust yet highly sophisticated assembly capable of ingesting liquid refrigerant without risk of damage. Contrast this to a reciprocating compressor, which can be destroyed by a single slug of liquid.

Series R™ Compressor Highlights

- Direct-drive, low speed for high efficiency and reliability.
- Simple design with only four moving parts, resulting in high reliability and low maintenance.
- Field serviceable compressor for easy maintenance.
- Precise rotor tip clearance for optimal efficiency.
- Suction gas-cooled motor, resulting in lower operating temperatures for increased motor life, and giving the capability for:
- Five-minute start-to-start/two minute stop-to-start capability, which allows for closer water loop temperature control.

Features and Benefits

RTAA 70-125 Chiller Highlights

- High Reliability, with over 99% compressor reliability rate in the first year of operation, and Adaptive Controls to keep the chiller on line producing cold water during adverse conditions.
- High Efficiency (all units exceed ASHRAE 90.1 efficiency standard).
- Low sound levels.
- Small footprint, with smallest required application space (operating footprint) in the industry.
- Years of research, testing, and successful applications. The Trane helical rotary compressor has amassed thousands of hours of testing, much of it at severe operating conditions. Not to mention the successful application of RTAA chillers for over 11 years, with a developed reputation as the industry standard.
- Trouble free startup through factory testing of compressor and completed chiller and factory installation of chiller accessories.
- +/- 1/2°F leaving water temperature control, resulting from PID feed-forward controls, and linear load matching, also allowing for 10% flow rate change per minute while maintaining ± 1/2°F leaving water temperature control.

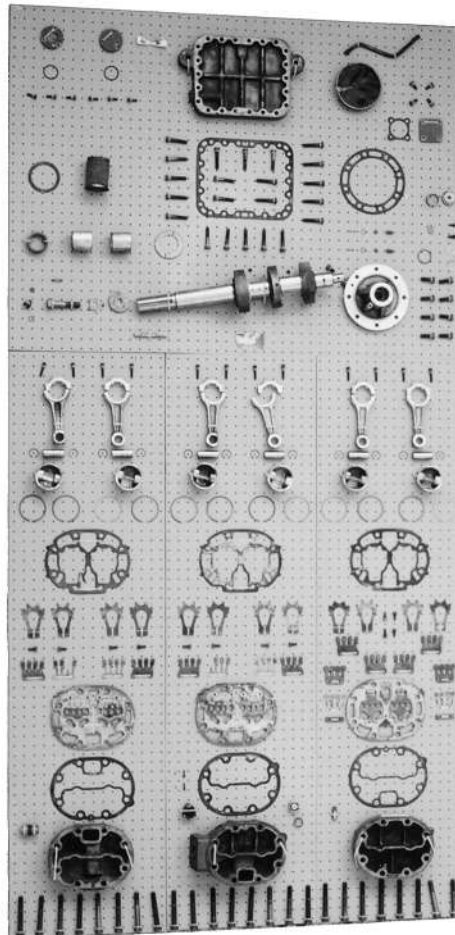

Trane helical rotary screw compressor component parts versus reciprocating compressor components.

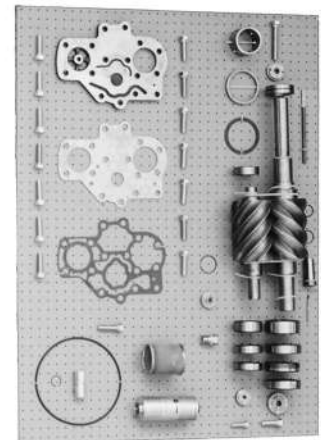

Features and Benefits

Optimum Efficiencies

Superior Full Load Efficiency

Precise Rotor Tip Clearances

Higher energy efficiency in a helical rotary compressor is obtained by reducing the rotor tip clearances. This reduces the leakage between high and low pressure cavities during compression. Precise rotor tip clearance is achieved with the latest manufacturing and machining technology. Trane is the first helical rotary compressor manufacturer to electronically check compressor parts machining accuracy as part of the standard production process.

Optimized Compressor Parts Profiles

Rotor and slide valves are unique designs, optimized for the air conditioning application. The rotors are designed for the pressure ranges in the air conditioning application. The unloader valve has a unique profile that resulted from computer performance modeling in typical part-load situations.

Advanced Heat Transfer Surfaces

Condenser and evaporator tubes use the latest heat transfer technology for increased efficiency.

Great Part Load Efficiency With Trane Helical Rotary Screw Compressors and Electronic Expansion Valve

Trane Helical Rotary Screw Compressor Means Superior Part Load Performance

The air-cooled Series R™ chiller has great part-load performance. The combination patented unloading system on the “general purpose” compressor utilizes the variable unloading valve for the majority of the unloading function similar to that of the slide valve. The “general purpose” compressor also uses a step unloader valve which is a single unloading step to achieve the minimum unloading point of the compressor. The result of both of these designs is optimized part-load performance far superior to single reciprocating compressors.

70-125 TON RTAA COMPRESSOR LOADING

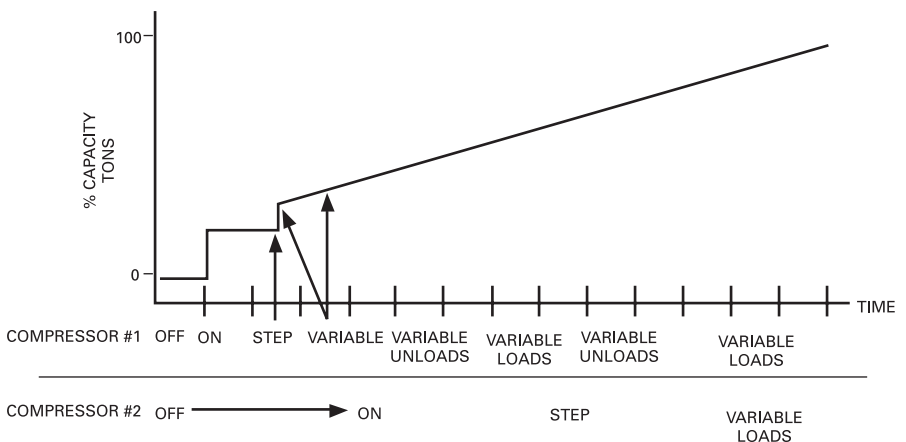

STEP = STEP UNLOADER VALVE

VARIABLE = VARIABLE UNLOADER VALVE

Features and Benefits

Electronic Expansion Valve

When coupled with Trane's Adaptive Control™ microprocessor, our electronic expansion valve significantly improves part-load performance of the Series R™ chiller by minimizing superheat in the evaporator and allowing the chiller to run at reduced condensing temperatures. Chillers which use conventional TXV's must run at higher head pressures and consume more power than necessary at part-loads. Additionally, the electronic expansion valve and its controls allow much better stability and control over dynamic load and head changes. Under these conditions a conventional TXV may never achieve control stability and extended periods of TXV "hunting" and liquid slugging are common.

Capacity Control and Load Matching

Infinitely variable compressor modulation allows the compressor capacity to exactly match the building cooling load. Reciprocating and screw chillers that rely on stepped capacity control must run at a capacity equal to or greater than the load. Much of this excess capacity is lost because overcooling goes toward building latent heat removal, causing the building to be dried beyond normal comfort requirements. The result is an increase in chiller energy costs, particularly at the part-load conditions at which the chiller operates most of the time.

PID Chilled Water Setpoint Control Through Slide Valve Modulation

Maintain Chilled Water Supply Within $\pm 1/2^\circ\text{F}$ of Setpoint

Chillers that have step capacity control typically can only maintain water temperature to around $\pm 2^\circ\text{F}$. With the air-cooled Series R™ chiller, maintaining temperature control has never been so accurate.

Reduce Compressor Cycling

Modulating capacity control offers better compressor reliability. Compressor cycling, typical of reciprocating compressors, will decrease compressor component life. Parts like motors and valves do not stand up well to excessive compressor cycling.



Cutaway view of Trane's electronic expansion valve.

Features and Benefits

Trouble-Free Installation, Start-Up and Operation

Adaptive Control™ Microprocessor

The RTAA 70-125 chiller offers advanced microprocessor control and features the Adaptive Control microprocessor. So what is the Adaptive Control microprocessor? Adaptive Control means the Unit Control Module (UCM) directly senses the control variables that govern operation of the chiller: motor current draw, evaporator temperature, condenser temperature, etc.

When any of the variables approaches a limit condition where the unit may be damaged or shut down on a safety, the UCM takes corrective action to avoid

shutdown and keep the chiller operating. It does this through combined actions of compressor slide valve modulation, electronic expansion valve modulation and fan staging. Additionally, the UCM optimizes total unit power consumption during normal operating conditions. No other chiller control system in the marketplace duplicates this performance.

The End Of Most Nuisance Trip-Outs And Unnecessary Service Calls?

Unnecessary service calls and unhappy tenants are reduced. Only when the UCM has exhausted the corrective actions it can take and the unit is still violating an operating limit will the unit shut down. CONTROLS ON OTHER

CHILLERS TYPICALLY SHUT DOWN THE CHILLER, QUITE PROBABLY JUST WHEN IT IS NEEDED THE MOST.

For example:

A typical five-year-old chiller with dirty coils might trip-out on high pressure cutout on a 100°F day in August. A hot day is just when comfort cooling is needed the most. In contrast, the air-cooled Series R™ chiller with an Adaptive Control microprocessor will stage fans on, modulate electronic expansion valve, and modulate slide valve as it approaches a high pressure cutout. Thereby KEEPING THE CHILLER ON-LINE JUST WHEN YOU NEED IT THE MOST.



Features and Benefits

Close Spacing Of Chiller

The air-cooled Series R™ chiller has the tightest recommended side clearance in the industry, four feet, but that is not all. In situations where equipment must be installed with less clearance than recommended, such as frequently occurs in retrofit and rooftop applications, restricted air flow is common. Conventional chillers may not work at all. However, the air-cooled Series R™ chiller with Adaptive Control™ microprocessor will simply make as much chilled water as it can given the actual installed conditions, stay on line during any unforeseen abnormal conditions, and optimize its performance. Consult your Trane sales engineer for more details.

Lower Service Expense

Nuisance service calls are avoided. When there is a real problem that must be corrected, the UCM's extensive diagnostics help assure that the problem is quickly identified. Down time and service expense are minimized. And with the ability to communicate with the Trane Integrated Comfort™ system or a remote display panel, service problems can be identified and diagnosed remote to the installation.

Factory Testing Means Trouble-Free Start-Up

All air-cooled Series R™ chillers are given a complete functional test at the factory. This computer-based test program completely checks the sensors, wiring, electrical components, microprocessor function, communication capability, expansion valve performance and fans. In addition, each compressor is run tested to verify capacity and power consumption. The end result of this test program is that the chiller arrives at the jobsite fully tested and ready to go to work.

Factory Installed And Tested Controls/Options Speed Installation

All Series R™ chiller options, including control power transformer, starter disconnect, low ambient control, ambient temperature sensor, low ambient lockout, communication interface and ice making controls are factory installed and tested. Some manufacturers send options in pieces to be field installed. With Trane, the customer saves on installation expense and has assurance that ALL chiller controls/options have been tested and will function as expected.

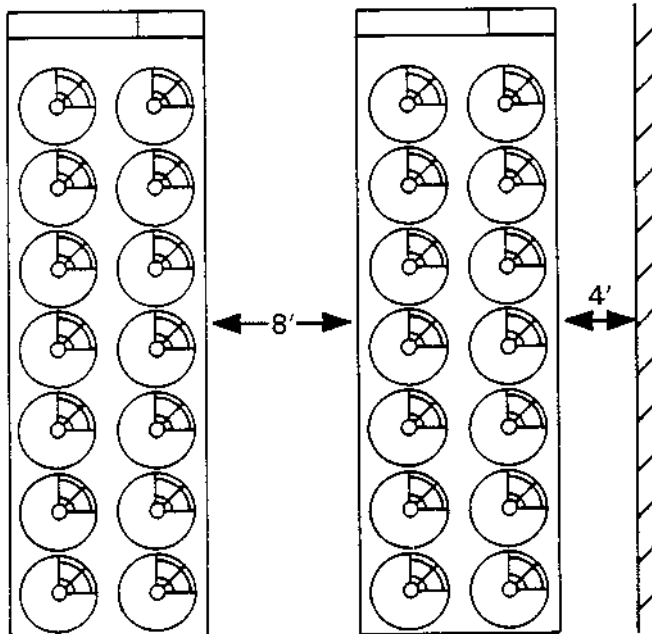

Features and Benefits

Superior Control

Unit Control Module

Trane's Adaptive Control™ microprocessor control system enhances the air-cooled Series R™ chiller by providing the very latest chiller control technology.

State-of-the-Art Equipment

The 70 to 125 ton air-cooled chillers offer the exclusive Trane Adaptive Control logic with the Clear Language Display (UCM). The Clear Language Display has various functions that allow the operator to read unit information and adjust setpoints. The Clear Language Display panel has 16 keys, the readout screen is a two-line, 40 character liquid crystal with a backlight. The backlight allows the operator to read the display in low-light conditions.

Unit Control Module Features

Equal Compressor Sequencing

Trane maximizes both compressor and motor life by equalizing both the number of starts and the operating hours. The UCM will start the compressor with the least number of starts and turn off the compressor with the most operating hours. Conventional "auto" lead-lag control will equalize starts, but running hours will typically be unequal. Equalizing both starts and running hours will provide equal compressor wear.

Internal "Built-In" Chiller Flow Protection

The UCM automatically detects a no waterflow condition. An external flow switch is not required, which lowers costs versus typical chillers. Built-in flow protection also eliminates nuisance flow switch problems.



Remote Clear Language Display Panel for 70 to 125-ton air-cooled chillers.



Features and Benefits

Easy Chiller System Logging

The UCM displays data required to log the chiller system. The following information is available either as standard or as an option with the Air-Cooled Series R™ Chiller microprocessor:

- Entering and leaving chilled water temperatures
- Ambient air temperature
- Evaporator and condenser refrigerant temperatures and pressures
- Compressor suction temperature
- Percent RLA for each compressor
- Percent line voltage
- Compressor starts and running hours
- Active setpoints:
 - chilled water setpoint
 - current limit setpoint
 - ice termination setpoint
 - low ambient lockout setpoint
- Over 90 diagnostic and operating conditions
- Part failure diagnostics:
 - water temperature sensors
 - refrigerant temperature sensors
 - compressor contactors

Remote Display Panel

Trane air-cooled Series R™ 70-125 ton chillers are available with a twisted pair connection to an optional remote display panel. Chiller operation can be controlled similarly to the control interface on the chiller itself. Through a twisted pair of wires the unit can be turned on or off, change the chilled water setpoint, and display over 90 operating and diagnostic conditions. The remote display panel can be mounted indoors so access to chiller information is just steps away, eliminating any need to go outdoors or on the roof.

The clear language display for chiller sizes of 70-125 tons has the ability to control multiple units. In a multiple unit configuration, the Remote Clear Language Display Panel has the capability to communicate with up to four units. Each unit requires a separate communication link with the Remote Display Panel.

Easy Interface To The Building Management System

Controlling the air-cooled Series R™ chiller with building management systems is state-of-the-art yet simple.

Chiller inputs include:

- Chiller enable/disable
- Circuit enable/disable
- Chilled water setpoint
- Current limit setpoint
- Ice making enable

Chiller outputs include:

- Compressor running indication
- Alarm indication (CKt 1/CKt2)
- Maximum capacity

Trane Chiller Plant Manager/ICS

The Tracer™ Chiller Plant Manager Building Management System provides building automation and energy management functions through stand-alone control. The Chiller Plant Manager is capable of monitoring and controlling your entire chiller plant system.

Application software available:

- Time-of-day scheduling
- Duty cycle
- Demand limiting
- Chiller sequencing
- Process control language
- Boolean processing
- Zone control
- Reports and logs
- Custom messages
- Run time and maintenance
- Trend log
- Totalizing
- PID control loops

And of course, Trane's Chiller Plant Manager Panel can be used on a stand-alone basis or tied into a complete building automation system.

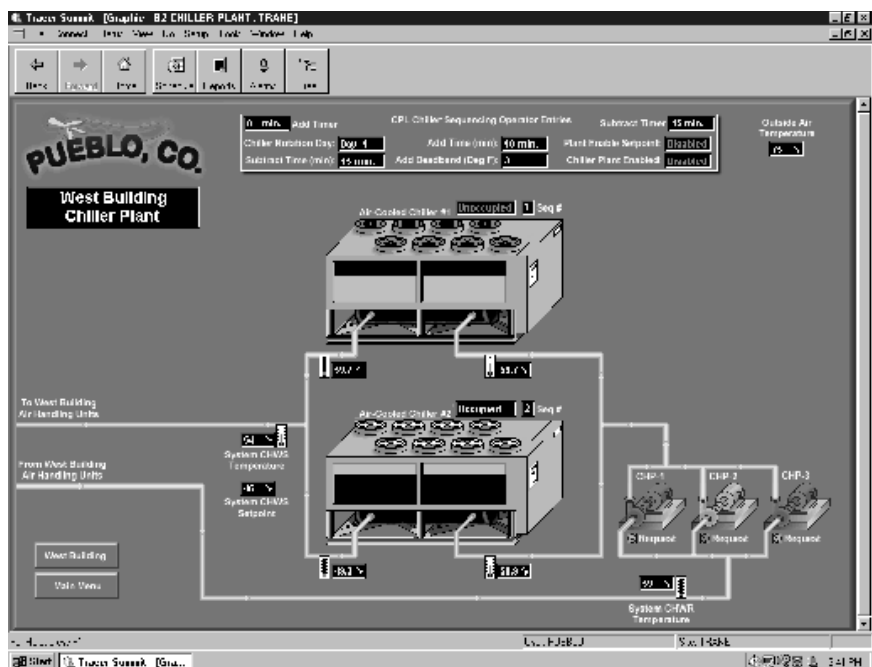

Model Number Description

Model Nomenclature Digit Number

1 2 3 4 5 6 7 8 9 10 11 12 13 14 15 16 17

70-125 Tons

Digits 1,2 — Unit Model

RT = Rotary Chiller

Digit 3 — Unit Type

A = Air Cooled

Digit 4 — Development Sequence

A = First Sequence

Digit 5, 6 & 7 — Nominal Capacity

070 = 70 tons

080 = 80 tons

090 = 90 tons

100 = 100 tons

110 = 110 tons

125 = 125 tons

Digit 8 — Unit Voltage

A = 200/60/3

C = 230/60/3

D = 380/60/3

4 = 460/60/3

5 = 575/60/3

S = Special

Digit 9 — Compressor Starter Type

Y = Y-Delta Closed Transition

X = X-Line (Across the Line)

S = Special

Digit 10, 11 — Design Sequence

** = Factory Input

Digit 12 — Evaporator Leaving Temperature

1 = Standard 40 to 65°F

2 = Low 0 to 39°F

3 = Ice-Making 20 to 65°F

S = Special

Digit 13 — Condenser Coil Fin Material

A = Aluminum

S = Special

2 = Copper Fins

4 = CompleteCoat

Digit 14 — Agency Listing

0 = No Agency Listing

3 = C/UL Listing

Digit 15 — Control Interface

C = Deluxe without Communication

D = Deluxe with Communication

Digit 16 — Chilled Water Reset

0 = No Chilled Water Reset

1 = Based on Return Water Temperature

2 = Based on Outside Air Temperature

Digit 17 — Miscellaneous Factory Installed Options

A = Architectural Louvered Panels

B = Control Power Transformer

C = Convenience Outlet

D = Low Ambient Lockout Sensor

F = Mech. Disconnect Switch

G = Low Ambient Operation

K = Coil Protection

M = Access Guard

P = Circuit Breaker (Single Point Power)

Z = Circuit Breaker (Dual Point Power)

Field Installed Options

Q = Spring Isolators

N = Neoprene Isolators

R = Remote Display Panel

3 = 5 Year Compressor Warranty

8 = Architectural Louvered Panels

9 = Coil Protection

0 = Access Guard

J = Remote Evaporator

H = Sound Attenuator



General Data

Table G-1 — General Data RTAA — 70-125 Ton

Size		70	80	90	100	110	125
Compressor							
Quantity		2	2	2	2	2	2
Nominal Size (1)	(Tons)	35/35	40/40	50/40	50/50	60/50	60/60
Evaporator							
Water Storage	(Gallons)	39.8	37.3	34.4	32.1	53.4	45.8
	(Liters)	150.6	143.1	130.2	121.5	202.11	173.4
Min. Flow	(GPM)	84	96	108	120	132	150
	(L/Sec)	5.3	6.1	6.8	7.6	8.3	9.5
Max. Flow	(GPM)	252	288	324	360	396	450
	(L/Sec)	15.9	18.2	20.4	22.7	25.0	28.4
Condenser							
Qty of Coils		4	4	4	4	4	4
Coil Length	(In)	156/156	156/156	168/156	168/168	204/168	204/204
Coil Height	(In)	42	42	42	42	42	42
Fins/Ft.		192	192	192	192	192	192
Number of Rows		2	2	2	2	2	2
Condenser Fans							
Quantity (1)		4/4	4/4	5/4	5/5	5/5	5/5
Diameter	(In)	30	30	30	30	30	30
Total Airflow	(CFM)	71750	71750	77640	83530	87505	91480
Nominal RPM		850	850	850	850	850	850
Tip Speed	(Ft/Min)	6675	6675	6675	6675	6675	6675
Motor HP (Ea)		1.0	1.0	1.0	1.0	1.0	1.0
Min Starting/Oper Ambient (2)							
Std Unit	(Deg F)	25	25	25	25	25	25
Low Ambient	(Deg F)	-10	-10	-10	-10	-10	-10
General Unit							
Refrigerant		HCFC-22	HCFC-22	HCFC-22	HCFC-22	HCFC-22	HCFC-22
No. of Independent Refrigerant Circuits		2	2	2	2	2	2
% Min. Load (3)		15	15	15	15	15	15
Refrigerant Charge (1)	(Lb)	58/58	61/61	73/61	73/73	98/73	98/98
	(Kg)	26/26	28/28	34/28	34/34	44/34	44/44
Oil Charge (1)	(Gallons)	2.5/2.5	2.5/2.5	3/2.5	3/3	3/3	3/3
	(Liters)	10.6/10.6	10.6/10.6	12.7/10.6	12.7/12.7	12.7/12.7	12.7/12.7

1. Data containing information on two circuits shown as follows: ckt 1/ckt2.
2. Minimum start-up/operating ambient based on a 5 mph wind across the condenser.
3. Percent minimum load is for total machine at 50°F ambient and 44°F LWT, not each individual circuit.

Selection Procedure

The chiller capacity tables, P-1 through P-12, cover the most frequently encountered leaving water temperatures. The tables reflect a 10°F (6°C) temperature drop through the evaporator. For temperature drops other than 10°F (6°C), refer to Table F-1, and apply the appropriate Performance Data Adjustment Factors. For chilled brine selections, refer to Figures F-2 and 3 for Ethylene and Propylene Glycol Adjustment Factors.

To select a Trane air-cooled Series R™ chiller, the following information is required:

1. Design load in tons of refrigeration
2. Design chilled water temperature drop
3. Design leaving chilled water temperature
4. Design ambient temperature

Evaporator flow rates can be determined by using the following formulas:

$$\text{GPM} = \frac{\text{Tons} \times 24}{\text{Temperature Drop (Degrees F)}}$$

$$\text{OR L/S} = \frac{\text{kW (Capacity)} \times .239}{\text{Temperature Drop (Degrees C)}}$$

NOTE: Flow rates must fall within the limits specified in Table G-1 (for GPM or for l/s).

Selection Example

Given:

Required System Load = 115 Tons
 Leaving Chilled Water Temperature (LCWT) = 44°F
 Chilled Water Temperature Drop = 10°F
 Design Ambient Temperature = 95°F
 Evaporator Fouling Factor = 0.0001

1. To calculate the required chilled water flow rate we use the formula given below:

$$\text{GPM} = \frac{115 \text{ Tons} \times 24}{10^\circ\text{F}} = 276 \text{ GPM}$$
2. From Table P-6 (RTAA Performance Data), an RTAA 125 at the given conditions will produce 120.1 tons with a compressor power input of 136.3 kW and a unit EER of 9.8.
3. To determine the evaporator pressure drop we use the flow rate (GPM) and the evaporator water pressure drop curves, Figure F-1. Entering the curve at 276 GPM, the pressure drop for a nominal 125 ton evaporator is 18 feet.
4. For selection of chilled brine units or applications where the altitude is significantly greater than sea level or the temperature drop is different than 10°F, the performance adjustment factors from Tables F-1, F-2, and/or F-3 should be applied at this point.

For example:

Corrected Capacity = Capacity (unadjusted) x Glycol Flow Rate Adjustment Factor

5. The final unit selection is:

- QTY (1) RTAA 125
- Cooling Capacity = 120.1 tons
- Entering/Leaving Chilled Water Temperatures = 54/44°F
- Chilled Water Flow Rate = 276 GPM
- Evaporator Water Pressure Drop = 18 feet
- Compressor Power Input = 136.3 kW
- Unit EER = 9.8

Minimum Leaving Chilled Water Temperature Setpoint

The minimum leaving chilled water temperature setpoint for water is 40°F. For those applications requiring lower setpoints, a glycol solution must be used. Contact the local Trane sales engineer for additional information.



Application Considerations

Application Considerations

Certain application constraints should be considered when sizing, selecting and installing Trane air-cooled Series R™ chillers. Unit and system reliability is often dependent upon properly and completely complying with these considerations. Where the application varies from the guidelines presented, it should be reviewed with your local Trane sales engineer.

Unit Sizing

Unit capacities are listed in the performance data section. Intentionally oversizing a unit to assure adequate capacity is not recommended. Erratic system operation and excessive compressor cycling are often a direct result of an oversized chiller. In addition, an oversized unit is usually more expensive to purchase, install, and operate. If oversizing is desired, consider using two units.

Unit Placement

1. Setting The Unit

A base or foundation is not required if the selected unit location is level and the base is strong enough to support the unit's operating weight as listed in Tables W-1 and W-2.

2. Isolation and Sound Emission

The most effective form of isolation is to locate the unit away from any sound-sensitive area. Structurally transmitted sound can be reduced by ELASTOMERIC vibration eliminators. Spring isolators have proven to be of little benefit on air-cooled Series R™ chiller installations and are not recommended. An acoustical engineer

should always be consulted in critical sound applications.

For maximum isolation effect, water lines and electrical conduit should also be isolated. Wall sleeves and rubber isolated piping hangers can be used to reduce the sound transmitted through water piping. To reduce the sound transmitted through electrical conduit, use flexible electrical conduit.

State and local codes on sound emissions should always be considered. Since the environment in which a sound source is located affects sound pressure, unit placement must be carefully evaluated. Sound power levels for Trane air-cooled Series R™ chillers are available on request.

3. Servicing

Adequate clearance for evaporator and compressor servicing should be provided. Recommended minimum space envelopes for servicing are located in the dimensional data section and can serve as a guideline for providing adequate clearance. The minimum space envelopes also allow for control panel swing and routine maintenance requirements. Local code requirements may take precedence.

4. Unit Location

a. General

Unobstructed flow of condenser air is essential to maintain chiller capacity and operating efficiency. When determining unit placement, careful consideration must be given to assuring a sufficient flow of air across the condenser heat transfer surface. Two detrimental conditions are possible and must be avoided if optimum performance is to be achieved: warm air recirculation and coil starvation.

Warm air recirculation occurs when discharge air from the condenser fans is recycled back to the condenser coil inlet.

Coil starvation occurs when free airflow to (or from) the condenser is restricted.

Both warm air recirculation and coil starvation cause reductions in unit efficiency and capacity because of the higher head pressures associated with them. The air-cooled Series R™ chiller offers an advantage over competitive equipment in these situations. Performance is minimally affected in many restricted air flow situations due to its unique condensing coil geometry. Also, through its advanced Adaptive Control™ microprocessor logic, the chiller will attempt to stay on-line where competitive chillers would usually shut down.

Trane's unique Adaptive Control microprocessor has the ability to understand the operating environment of the chiller and adapt to it by first optimizing its performance and second, staying on line through abnormal conditions. For example, high ambient temperatures combined with a restricted air flow situation will generally not cause the air-cooled Series R™ chiller to shut down. Competitive chillers would typically shut down on a high pressure nuisance cut-out in these conditions.

Debris, trash, supplies, etc. should not be allowed to accumulate in the vicinity of the air-cooled Series R™ chiller. Supply air movement may draw debris into the condenser coil, blocking spaces between coil fins and causing coil starvation.

Special consideration should be given to low ambient units. Condenser coils and fan discharge must be kept free of obstructions to permit adequate airflow for satisfactory unit operation.

Application Considerations

b. Provide Vertical Clearance

Vertical condenser air discharge must be unobstructed. While it is difficult to predict the degree of warm air circulation, a unit installed as shown on the left would have its capacity and efficiency significantly reduced. Performance data is based on free air discharge.

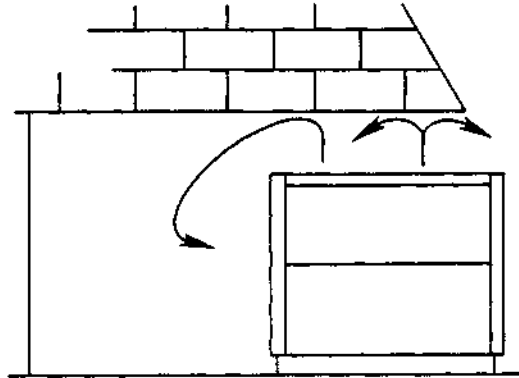

c. Provide Lateral Clearance

The condenser coil inlet must not be obstructed. A unit installed closer than the minimum recommended distance to a wall or other vertical riser may experience a combination coil starvation and warm air recirculation, resulting in unit capacity and efficiency reductions. Once again, the Adaptive Control™ microprocessor will allow the chiller to stay on line, producing the maximum available capacity, even at less than recommended lateral clearances. The recommended lateral clearances are depicted in the dimensional data section. These are estimates and should be reviewed with the local Trane sales engineer at the jobsite.

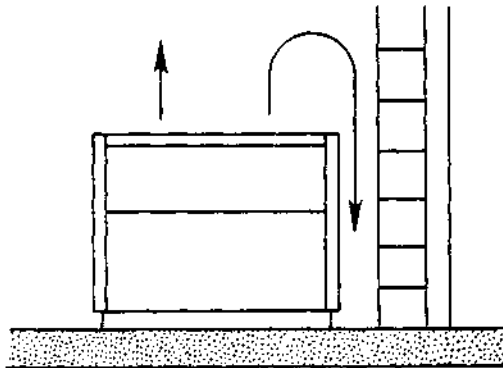

d. Provide Sufficient Unit-to-Unit Clearance

Units should be separated from each other by a sufficient distance to prevent warm air recirculation or coil starvation. The air-cooled Series R™ chiller has the lowest recommended unit-to-unit clearance in the industry, eight feet. Consult the local Trane sales engineer for applications concerning close spacing and restricted airflows.



e. Walled Enclosure Installations

When the unit is placed in an enclosure or small depression, the top of the fans should be no lower than the top of the enclosure or depression. If they are, consideration should be given to ducting the top of the unit. Ducting individual fans, however, is not recommended. Such applications should always be reviewed with the local Trane sales engineer.

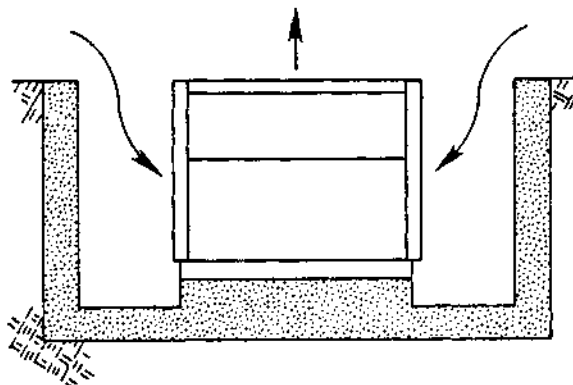



Application Considerations

Water Treatment

Dirt, scale, products of corrosion and other foreign material will adversely affect heat transfer between the water and system components. Foreign matter in the chilled water system can also increase pressure drop and, consequently, reduce waterflow. Proper water treatment must be determined locally, depending on the type of system and local water characteristics.

Neither salt nor brackish water is recommended for use in Trane air-cooled Series R™ chillers. Use of either will lead to a shortened life to an indeterminable degree. The Trane Company encourages the employment of a reputable water treatment specialist, familiar with local water conditions, to assist in this determination and in the establishment of a proper water treatment program.

The capacities given in the performance data section of this catalog are based on water with a fouling factor of .00010. For capacities at other fouling factors, see adjustment factors in Table F-1.

Effect Of Altitude On Capacity

Air-cooled Series R™ chiller capacities given in the performance data tables, P-1 through P-12, are for use at sea level. At elevations substantially above sea level, the decreased air density will decrease condenser capacity and, therefore, unit capacity and efficiency. The adjustment factors in Table F-1 can be applied directly to the catalog performance data to determine the unit's adjusted performance.

Ambient Limitations

Trane air-cooled Series R™ chillers are designed for year-round applications over a range of ambients. Chillers from 70-125 tons offer operation for ambients from 25 to 115°F as standard, and will operate down to -10°F with the low ambient option.

The minimum ambient temperatures are based on still conditions (winds not exceeding five mph). Greater wind velocities will result in a drop in head pressure, therefore increasing the minimum starting and operating ambient temperature. Once again, the Adaptive Control™ microprocessor will attempt to keep the chiller on-line when high or low ambient conditions exist, making every effort to avoid nuisance trip-outs and provide the maximum allowable tonnage.

Waterflow Limits

The minimum waterflow rates are given in Table G-1. Evaporator flow rates below the tabulated values will result in laminar flow causing freeze-up problems, scaling, stratification and poor control.

The maximum evaporator waterflow rate is also given in the general data section. Flow rates exceeding those listed may result in excessive tube and baffle erosion.

The evaporator can withstand up to 50 percent water flow reduction as long as this flow is equal or above the minimum gpm requirements.

Variable Evaporator Flow

Air-cooled Series R™ chillers have the capability to handle variable evaporator flow without losing leaving water temperature control. Flow rates can be varied up to 10% of design without decreasing the leaving water temperature control capabilities.

Temperature Limits

1. Leaving Water Temperature Range

Trane air-cooled Series R™ chillers have three distinct leaving water categories: standard, low temperature, and ice making.

The standard leaving water temperature range is 40 to 65°F. Low temperature machines produce leaving water temperatures between 0°F and 39°F. Since water supply temperature setpoints from 0 to 39°F result in suction temperatures at or below the freezing point of water, a glycol solution is required for all low temperature machines. Ice making machines have a leaving water temperature range of 20 to 65°F. Ice making controls include dual setpoint controls and safeties for ice making and standard cooling capabilities. Consult your local Trane sales engineer for applications or selections involving low temperature or ice making machines.

The maximum water temperature that can be circulated through an evaporator when the unit is not operating is 108°F. The evaporator becomes thermal stress limited at this temperature.

2. Supply Water Temperature Drop

The performance data for the Trane air-cooled Series R™ chiller is based on a chilled water temperature drop of 10°F. Temperature drops outside this range will result in unit performance that differs from that cataloged. For performance data outside the 10°F range, see Table F-1 for adjustment factors. Chilled water temperature drops from 6 to 18°F may be used as long as minimum and maximum water temperature and minimum and maximum flow rates are not violated.

Temperature drops outside 6 to 18°F are beyond the optimum range for control and may adversely affect the microcomputer's ability to maintain an acceptable supply water temperature range.

Further, temperature drops of less than 6°F may result in inadequate refrigerant superheat. Sufficient superheat is always a primary concern in any direct expansion refrigerant system and is especially important in a package chiller where the evaporator is closely coupled to the compressor. When temperature drops are less than 6°F, an evaporator runaround loop may be required.

Application Considerations

Typical Water Piping

All building water piping must be flushed prior to making final connections to the chiller. To reduce heat loss and prevent condensation, insulation should be installed. Expansion tanks are also usually required so that chilled water volume changes can be accommodated. A typical piping arrangement is shown in Figure A-1.

Short Water Loops

The proper location of the temperature control sensor is in the supply (outlet) water. This location allows the building to act as a buffer and assures a slowly changing return water temperature. If there is not a sufficient volume of water in the system to provide an adequate buffer, temperature control can be lost, resulting in erratic system operation and excessive compressor cycling. A short water loop has the same effect as attempting to control from the building return water.

The Air-Cooled Series R™ 70-125 ton chiller has excellent leaving chilled water control capabilities because of exceptional controls, EXV and linear

unloading. However, it is still a good idea to make sure the evaporator water loop is sized sufficiently to help maintain temperature control.

As a guideline, ensure the volume of water in the evaporator loop equals or exceeds two times the evaporator flow rate. For a rapidly changing load profile, the amount of volume should be increased.

To prevent the effect of a short water loop, the following items should be given careful consideration:

A storage tank or larger header pipe to increase the volume of water in the system and, therefore, reduce the rate of change of the return water temperature.

Multiple Unit Operation

Whenever two or more units are used on one chilled water loop, Trane recommends that their operation be controlled from a single control device, such as a Trane Tracer™ system.

1. Series Operation

Some systems require large chilled water temperature drops (16 to 24°F). For those installations, two units with their evaporators in series are usually required. Control of the units should be from a common temperature controller to prevent the separate thermostats fighting one another and continually hunting. It is possible to control from the two individual unit controls, but a common temperature controller provides a positive method for preventing control overlap, more closely matches system load, and simplifies compressor lead-lag capability.

2. Parallel Operation

Some systems require more capacity or standby capability than a single machine can provide. For those installations, two units with their evaporators in a parallel configuration are typical. The only effective way of controlling two units in parallel is with a single temperature controller. Two individual temperature controllers are not capable of providing reliable system control and will often result in unsatisfactory operation.

Figure A-1 — Recommended Piping Components For Typical Evaporator Installation

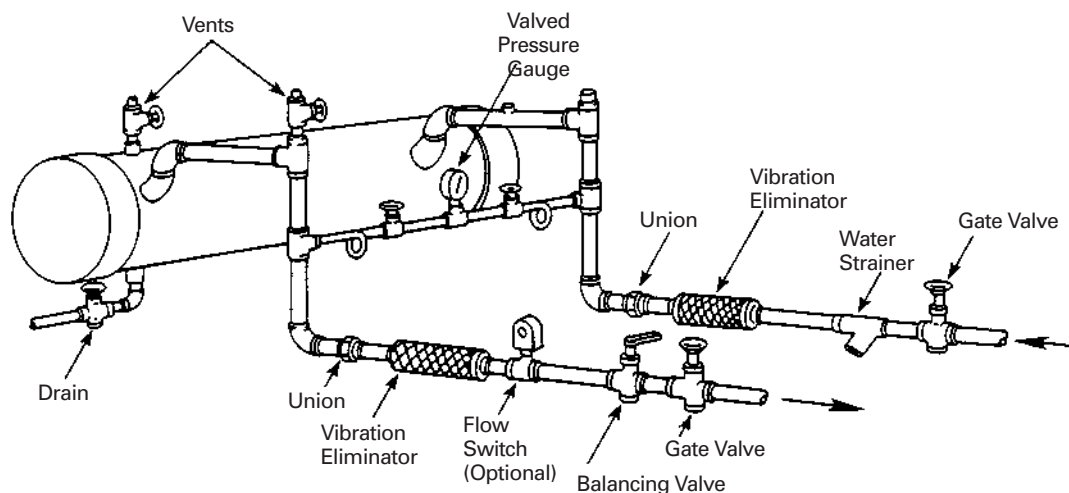



Performance Adjustment Factors

Table F-1 — Performance Data Adjustment Factors

Fouling Factor	Chilled Water Temp. Drop	Altitude											
		Sea Level			2000 Feet			4000 Feet			6000 Feet		
		CAP	GPM	KW	CAP	GPM	KW	CAP	GPM	KW	CAP	GPM	KW
0.00010	8	1.000	1.249	1.000	0.996	1.245	1.004	0.991	1.240	1.007	0.987	1.234	1.014
	10	1.000	1.000	1.000	0.997	0.996	1.004	0.993	0.992	1.007	0.988	0.988	1.015
	12	1.001	0.835	1.001	0.997	0.832	1.004	0.993	0.828	1.009	0.988	0.824	1.015
	14	1.003	0.716	1.001	0.999	0.714	1.004	0.994	0.711	1.009	0.990	0.708	1.015
	16	1.004	0.628	1.001	1.000	0.626	1.005	0.997	0.623	1.009	0.991	0.620	1.016
0.00025	8	0.988	1.235	0.996	0.984	1.230	1.000	0.980	1.225	1.004	0.975	1.220	1.010
	10	0.988	0.989	0.998	0.986	0.985	1.000	0.981	0.981	1.004	0.977	0.976	1.011
	12	0.990	0.825	0.998	0.987	0.822	1.000	0.983	0.819	1.005	0.978	0.815	1.011
	14	0.991	0.708	0.998	0.988	0.706	1.001	0.984	0.703	1.005	0.980	0.700	1.011
	16	0.993	0.621	0.999	0.990	0.619	1.001	0.986	0.617	1.006	0.981	0.614	1.012

Figure F-1 — Evaporator Water Pressure Drops, 70-125 Ton Units

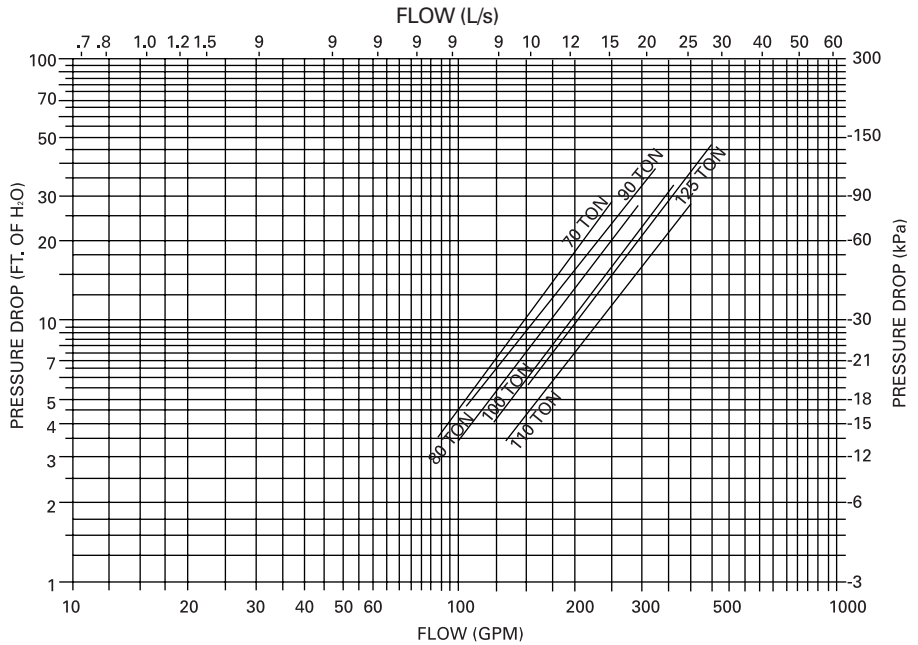

Performance Adjustment Factors

Figure F-2 — Ethylene Glycol Performance Factors

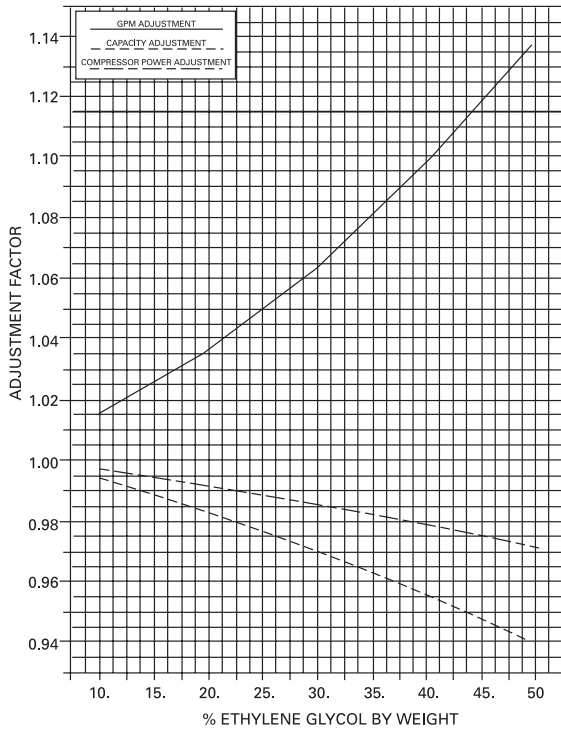

Figure F-3 — Propylene Glycol Performance Factors

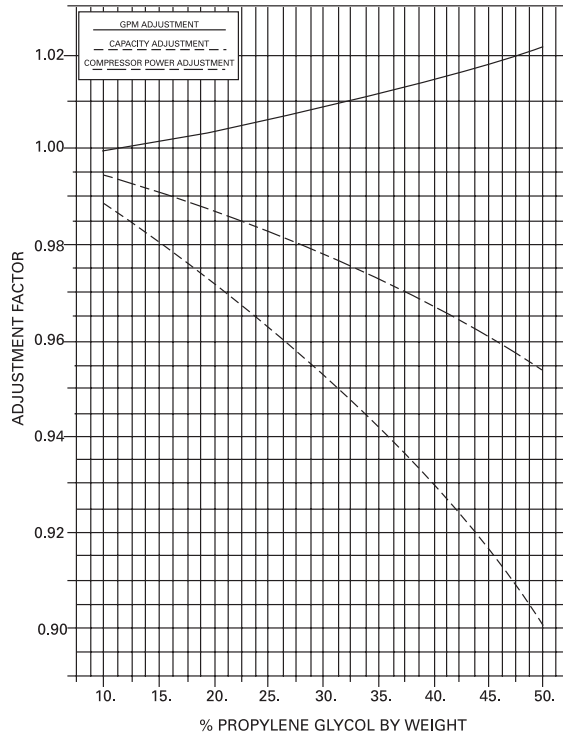
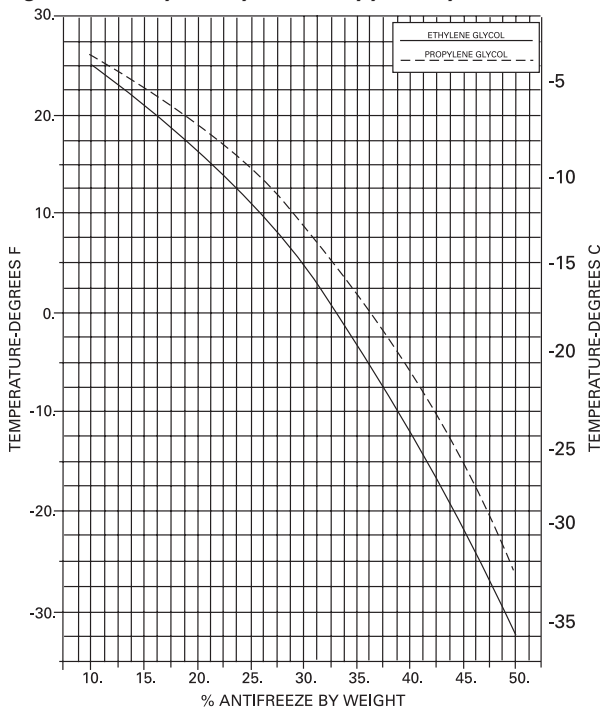

Figure F-4 — Ethylene Glycol and Propylene Glycol Freeze Point





Performance Data

Table P-1 — 60 Hz RTAA 70 Performance Data

English

LWT (Deg. F)	Entering Condenser Air Temperature (Degrees F)														
	75			85			95			105			115		
	Tons	kW	EER	Tons	kW	EER	Tons	kW	EER	Tons	kW	EER	Tons	kW	EER
40	72.6	58.6	12.9	68.7	64.3	11.2	64.6	70.8	9.7	60.4	77.9	8.4	55.5	84.8	7.1
42	75.0	59.4	13.1	71.1	65.1	11.5	66.9	71.6	10.0	62.6	78.7	8.6	57.1	84.8	7.3
44	77.6	60.2	13.4	73.5	65.9	11.8	69.3	72.4	10.2	64.9	79.6	8.8	58.6	84.8	7.5
46	80.2	61.1	13.7	76.0	66.8	12.0	71.7	73.2	10.5	67.2	80.5	9.0	60.2	84.8	7.7
48	82.8	61.9	14.0	78.5	67.6	12.3	74.1	74.1	10.7	69.5	81.4	9.3	61.8	84.8	7.9
50	85.4	62.8	14.3	81.1	68.5	12.6	76.5	75.0	11.0	71.8	82.3	9.5	63.4	84.8	8.1
55	92.2	64.9	14.9	87.6	70.6	13.2	82.8	77.2	11.6	77.8	84.7	10.0	67.3	84.6	8.7

- Notes:
1. Ratings based on sea level altitude and evaporator fouling factor of 0.00010.
 2. Consult Trane representative for performance at temperatures outside of the ranges shown.
 3. kW input is for compressors only.
 4. EER = Energy Efficiency Ratio (Btu/watt-hour). Power inputs include compressors, condenser fans and control power.
 5. Ratings are based on an evaporator temperature drop of 10°F.
 6. 115°F performance data reflects Adaptive Control Microprocessor control algorithms.
 7. Interpolation between points is permissible. Extrapolation is not permitted.
 8. Rated in accordance with ARI Standard 550/590-98.

Metric

LWT (Deg. C)	Entering Condenser Air Temperature (Degrees C)											
	30			35			40			45		
	kWo	kWi	COP	kWo	kWi	COP	kWo	kWi	COP	kWo	kWi	COP
6	251.7	66.1	3.4	238.7	71.9	3.0	225.0	78.3	2.6	209.6	84.8	2.2
8	267.6	67.6	3.5	253.5	73.4	3.1	239.4	79.9	2.7	219.8	84.9	2.4
10	283.4	69.1	3.6	269.0	75.0	3.2	254.2	81.5	2.8	229.6	84.8	2.5

- Notes:
1. Ratings based on sea level altitude and evaporator fouling factor of 0.0000176.
 2. Consult Trane representative for performance at temperatures outside of the ranges shown.
 3. kWi input is for compressors only.
 4. COP = Coefficient of Performance (kWo/kWi). Power inputs include compressors, condenser fans and control power.
 5. Ratings are based on an evaporator temperature drop of 5.6°C.
 6. 115°F performance data reflects Adaptive Control Microprocessor control algorithms.
 7. Interpolation between points is permissible. Extrapolation is not permitted.
 8. Rated in accordance with ARI Standard 550/590-98.

Table P-2 — 60 Hz RTAA 80 Performance Data

English

LWT (Deg. F)	Entering Condenser Air Temperature (Degrees F)														
	75			85			95			105			115		
	Tons	kW	EER	Tons	kW	EER	Tons	kW	EER	Tons	kW	EER	Tons	kW	EER
40	83.0	68.9	12.8	78.8	75.6	11.2	74.4	83.1	9.7	69.8	91.3	8.4	65.0	100.4	7.2
42	86.0	70.1	13.0	81.6	76.8	11.4	77.1	84.2	9.9	72.3	92.5	8.6	67.4	101.6	7.3
44	89.0	71.3	13.3	84.5	78.0	11.7	79.8	85.4	10.2	74.9	93.7	8.8	69.9	102.8	7.5
46	92.0	72.5	13.5	87.4	79.2	11.9	82.6	86.6	10.4	77.6	94.9	9.0	72.4	104.1	7.7
48	95.2	73.8	13.8	90.4	80.4	12.1	85.4	87.9	10.6	80.3	96.2	9.2	74.4	104.7	7.9
50	98.3	75.1	14.0	93.4	81.7	12.4	88.3	89.1	10.8	83.0	97.4	9.4	75.9	104.8	8.0
55	106.5	78.3	14.6	101.3	84.9	13.0	95.8	92.4	11.4	90.1	100.7	9.9	80.0	105.0	8.5

- Notes:
1. Ratings based on sea level altitude and evaporator fouling factor of 0.00010.
 2. Consult Trane representative for performance at temperatures outside of the ranges shown.
 3. kW input is for compressors only.
 4. EER = Energy Efficiency Ratio (Btu/watt-hour). Power inputs include compressors, condenser fans and control power.
 5. Ratings are based on an evaporator temperature drop of 10°F.
 6. 115°F performance data reflects Adaptive Control Microprocessor control algorithms.
 7. Interpolation between points is permissible. Extrapolation is not permitted.
 8. Rated in accordance with ARI Standard 550/590-98.

Metric

LWT (Deg. C)	Entering Condenser Air Temperature (Degrees C)											
	30			35			40			45		
	kWo	kWi	COP	kWo	kWi	COP	kWo	kWi	COP	kWo	kWi	COP
6	289.4	77.9	3.3	275.0	84.7	2.9	259.8	92.1	2.6	244.0	100.2	2.2
8	307.7	80.1	3.5	292.5	86.9	3.1	276.4	94.3	2.7	259.8	102.4	2.3
10	326.6	82.4	3.6	310.5	89.1	3.2	293.9	96.6	2.8	276.4	104.7	2.4

- Notes:
1. Ratings based on sea level altitude and evaporator fouling factor of 0.0000176.
 2. Consult Trane representative for performance at temperatures outside of the ranges shown.
 3. kWi input is for compressors only.
 4. COP = Coefficient of Performance (kWo/kWi). Power inputs include compressors, condenser fans and control power.
 5. Ratings are based on an evaporator temperature drop of 5.6°C.
 6. 115°F performance data reflects Adaptive Control Microprocessor control algorithms.
 7. Interpolation between points is permissible. Extrapolation is not permitted.
 8. Rated in accordance with ARI Standard 550/590-98.

Performance Data

Table P-3 — 60 Hz RTAA 90 Performance Data

English

LWT (Deg. F)	Entering Condenser Air Temperature (Degrees F)														
	75			85			95			105			115		
	Tons	kW	EER	Tons	kW	EER	Tons	kW	EER	Tons	kW	EER	Tons	kW	EER
40	94.7	81.9	12.3	89.9	88.9	10.9	84.8	97.0	9.5	79.5	106.2	8.2	73.9	116.4	7.0
42	97.9	83.3	12.6	93.0	90.3	11.1	87.8	98.4	9.7	82.3	107.5	8.4	76.5	117.8	7.2
44	101.2	84.7	12.8	96.2	91.7	11.3	90.8	99.8	9.9	85.1	108.9	8.6	79.2	119.2	7.4
46	104.6	86.2	13.0	99.4	93.2	11.6	93.8	101.2	10.1	88.0	110.4	8.8	81.7	120.4	7.5
48	108.1	87.7	13.3	102.6	94.6	11.8	96.9	102.7	10.3	91.0	111.8	9.0	82.9	120.1	7.7
50	111.5	89.2	13.5	106.0	96.2	12.0	100.1	104.2	10.5	93.9	113.3	9.2	84.3	120.0	7.8
55	120.5	93.2	14.0	114.5	100.1	12.5	108.2	108.1	11.0	101.6	117.2	9.6	88.4	119.6	8.2

Notes:

1. Ratings based on sea level altitude and evaporator fouling factor of 0.00010.
2. Consult Trane representative for performance at temperatures outside of the ranges shown.
3. kW input is for compressors only.
4. EER = Energy Efficiency Ratio (Btu/watt-hour). Power inputs include compressors, condenser fans and control power.
5. Ratings are based on an evaporator temperature drop of 10°F.
6. 115°F performance data reflects Adaptive Control Microprocessor control algorithms.
7. Interpolation between points is permissible. Extrapolation is not permitted.
8. Rated in accordance with ARI Standard 550/590-98.

Metric

LWT (Deg. C)	Entering Condenser Air Temperature (Degrees C)											
	30			35			40			45		
	kWo	kWi	COP	kWo	kWi	COP	kWo	kWi	COP	kWo	kWi	COP
6	329.4	91.6	3.2	312.9	98.9	2.9	295.3	107.1	2.5	277.1	116.2	2.2
8	349.8	94.2	3.4	332.3	101.5	3.0	313.6	109.7	2.6	294.3	118.8	2.3
10	370.6	96.9	3.5	352.0	104.2	3.1	332.6	112.4	2.7	307.7	120.0	2.4

Notes:

1. Ratings based on sea level altitude and evaporator fouling factor of 0.0000176.
2. Consult Trane representative for performance at temperatures outside of the ranges shown.
3. kW input is for compressors only.
4. COP = Coefficient of Performance (kWo/kWi). Power inputs include compressors, condenser fans and control power.
5. Ratings are based on an evaporator temperature drop of 5.6°C.
6. 115°F performance data reflects Adaptive Control Microprocessor control algorithms.
7. Interpolation between points is permissible. Extrapolation is not permitted.
8. Rated in accordance with ARI Standard 550/590-98.

Table P-4 — 60 Hz RTAA 100 Performance Data

English

LWT (Deg. F)	Entering Condenser Air Temperature (Degrees F)														
	75			85			95			105			115		
	Tons	kW	EER	Tons	kW	EER	Tons	kW	EER	Tons	kW	EER	Tons	kW	EER
40	105.1	94.3	12.0	99.9	101.7	10.6	94.2	110.5	9.3	88.2	120.5	8.1	81.9	131.9	6.9
42	108.6	95.9	12.2	103.2	103.3	10.8	97.4	112.0	9.5	91.2	122.1	8.2	84.7	133.5	7.1
44	112.2	97.5	12.4	106.6	104.9	11.0	100.6	113.6	9.7	94.3	123.7	8.4	87.6	135.1	7.2
46	115.9	99.2	12.6	110.1	106.6	11.2	103.9	115.3	9.9	97.4	125.3	8.6	90.6	136.7	7.4
48	119.6	101.0	12.8	113.6	108.3	11.4	107.3	117.0	10.1	100.6	127.0	8.8	92.0	136.7	7.5
50	123.4	102.8	13.0	117.2	110.1	11.6	110.7	118.7	10.3	103.8	128.7	8.9	93.4	136.6	7.6
55	133.1	107.5	13.5	126.5	114.7	12.1	119.4	123.2	10.7	112.0	133.1	9.3	98.1	136.6	8.0

Notes:

1. Ratings based on sea level altitude and evaporator fouling factor of 0.00010.
2. Consult Trane representative for performance at temperatures outside of the ranges shown.
3. kW input is for compressors only.
4. EER = Energy Efficiency Ratio (Btu/watt-hour). Power inputs include compressors, condenser fans and control power.
5. Ratings are based on an evaporator temperature drop of 10°F.
6. 115°F performance data reflects Adaptive Control Microprocessor control algorithms.
7. Interpolation between points is permissible. Extrapolation is not permitted.
8. Rated in accordance with ARI Standard 550/590-98.

Metric

LWT (Deg. C)	Entering Condenser Air Temperature (Degrees C)											
	30			35			40			45		
	kWo	kWi	COP	kWo	kWi	COP	kWo	kWi	COP	kWo	kWi	COP
6	365.7	104.8	3.2	347.0	112.7	2.8	327.3	121.6	2.5	306.6	131.7	2.2
8	387.5	107.7	3.3	367.8	115.6	2.9	347.0	124.6	2.6	325.6	134.7	2.2
10	410.0	110.9	3.4	389.2	118.7	3.0	367.4	127.7	2.7	341.1	136.5	2.3

Notes:

1. Ratings based on sea level altitude and evaporator fouling factor of 0.0000176.
2. Consult Trane representative for performance at temperatures outside of the ranges shown.
3. kW input is for compressors only.
4. COP = Coefficient of Performance (kWo/kWi). Power inputs include compressors, condenser fans and control power.
5. Ratings are based on an evaporator temperature drop of 5.6°C.
6. 115°F performance data reflects Adaptive Control Microprocessor control algorithms.
7. Interpolation between points is permissible. Extrapolation is not permitted.
8. Rated in accordance with ARI Standard 550/590-98.



Performance Data

Table P-5 — 60 Hz RTAA 110 Performance Data

English

LWT (Deg. F)	Entering Condenser Air Temperature (Degrees F)														
	75			85			95			105			115		
	Tons	kW	EER	Tons	kW	EER	Tons	kW	EER	Tons	kW	EER	Tons	kW	EER
40	113.3	102.5	11.9	107.7	110.7	10.6	101.7	120.3	9.3	95.2	131.2	8.1	88.4	143.6	6.9
42	117.1	104.3	12.2	111.3	112.4	10.8	105.1	122.0	9.5	98.4	132.9	8.2	91.5	145.3	7.0
44	120.9	106.1	12.4	114.9	114.2	11.0	108.5	123.7	9.7	101.7	134.7	8.4	94.6	147.1	7.2
46	124.8	107.9	12.6	118.6	116.0	11.2	112.0	125.5	9.9	105.1	136.4	8.6	97.7	148.9	7.4
48	128.8	109.8	12.8	122.4	117.8	11.4	115.6	127.3	10.0	108.5	138.3	8.7	99.4	148.9	7.5
50	132.8	111.7	13.0	126.2	119.7	11.6	119.3	129.2	10.2	111.9	140.1	8.9	101.0	148.7	7.6
55	143.1	116.7	13.4	136.1	124.7	12.0	128.6	134.1	10.7	120.6	144.9	9.3	103.6	145.4	8.0

- Notes:
1. Ratings based on sea level altitude and evaporator fouling factor of 0.00010.
 2. Consult Trane representative for performance at temperatures outside of the ranges shown.
 3. kW input is for compressors only.
 4. EER = Energy Efficiency Ratio (Btu/watt-hour). Power inputs include compressors, condenser fans and control power.
 5. Ratings are based on an evaporator temperature drop of 10°F.
 6. 115°F performance data reflects Adaptive Control Microprocessor control algorithms.
 7. Interpolation between points is permissible. Extrapolation is not permitted.
 8. Rated in accordance with ARI Standard 550/590-98.

Metric

LWT (Deg. C)	Entering Condenser Air Temperature (Degrees C)											
	30			35			40			45		
	kWo	kWi	COP	kWo	kWi	COP	kWo	kWi	COP	kWo	kWi	COP
6	394.1	114.0	3.2	374.1	122.6	2.8	353.0	132.4	2.5	331.2	143.4	2.2
8	417.3	117.2	3.3	396.6	125.8	2.9	374.5	135.6	2.6	351.2	146.7	2.2
10	441.6	120.6	3.4	419.5	129.2	3.0	395.9	139.0	2.7	369.5	149.2	2.3

- Notes:
1. Ratings based on sea level altitude and evaporator fouling factor of 0.0000176.
 2. Consult Trane representative for performance at temperatures outside of the ranges shown.
 3. kW input is for compressors only.
 4. COP = Coefficient of Performance (kWo/kWi). Power inputs include compressors, condenser fans and control power.
 5. Ratings are based on an evaporator temperature drop of 5.6°C.
 6. 115°F performance data reflects Adaptive Control Microprocessor control algorithms.
 7. Interpolation between points is permissible. Extrapolation is not permitted.
 8. Rated in accordance with ARI Standard 550/590-98.

Table P-6 — 60 Hz RTAA 125 Performance Data

English

LWT (Deg. F)	Entering Condenser Air Temperature (Degrees F)														
	75			85			95			105			115		
	Tons	kW	EER	Tons	kW	EER	Tons	kW	EER	Tons	kW	EER	Tons	kW	EER
40	125.7	113.2	12.1	119.3	122.0	10.8	112.4	132.3	9.4	105.2	144.1	8.2	97.6	157.5	7.0
42	129.9	115.2	12.3	123.3	124.0	11.0	116.2	134.3	9.6	108.8	146.1	8.3	100.9	159.5	7.1
44	134.1	117.2	12.5	127.3	126.0	11.2	120.1	136.3	9.8	112.4	148.1	8.5	104.3	161.5	7.3
46	138.5	119.4	12.7	131.4	128.1	11.3	124.0	138.3	10.0	116.1	150.1	8.7	106.7	162.2	7.4
48	142.9	121.5	12.9	135.6	130.2	11.5	127.9	140.4	10.2	119.8	152.2	8.8	107.2	160.2	7.5
50	147.4	123.7	13.1	139.9	132.4	11.7	132.0	142.6	10.3	123.6	154.4	9.0	107.6	158.0	7.7
55	159.0	129.5	13.6	150.9	138.0	12.2	142.3	148.1	10.7	133.2	159.8	9.4	109.5	152.1	8.1

- Notes:
1. Ratings based on sea level altitude and evaporator fouling factor of 0.00010.
 2. Consult Trane representative for performance at temperatures outside of the ranges shown.
 3. kW input is for compressors only.
 4. EER = Energy Efficiency Ratio (Btu/watt-hour). Power inputs include compressors, condenser fans and control power.
 5. Ratings are based on an evaporator temperature drop of 10°F.
 6. 115°F performance data reflects Adaptive Control Microprocessor control algorithms.
 7. Interpolation between points is permissible. Extrapolation is not permitted.
 8. Rated in accordance with ARI Standard 550/590-98.

Metric

LWT (Deg. C)	Entering Condenser Air Temperature (Degrees C)											
	30			35			40			45		
	kWo	kWi	COP	kWo	kWi	COP	kWo	kWi	COP	kWo	kWi	COP
6	436.7	125.7	3.2	414.2	135.1	2.8	390.3	145.6	2.5	365.3	157.5	2.2
8	462.7	129.4	3.3	438.8	138.7	2.9	413.5	149.3	2.6	387.5	161.2	2.3
10	489.1	133.3	3.4	464.1	142.6	3.0	437.7	153.1	2.7	410.0	165.0	2.3

- Notes:
1. Ratings based on sea level altitude and evaporator fouling factor of 0.0000176.
 2. Consult Trane representative for performance at temperatures outside of the ranges shown.
 3. kW input is for compressors only.
 4. COP = Coefficient of Performance (kWo/kWi). Power inputs include compressors, condenser fans and control power.
 5. Ratings are based on an evaporator temperature drop of 5.6°C.
 6. 115°F performance data reflects Adaptive Control Microprocessor control algorithms.
 7. Interpolation between points is permissible. Extrapolation is not permitted.
 8. Rated in accordance with ARI Standard 550/590-98.

Performance Data

Table P-7 — 50 Hz RTAA 70 Performance Data
English

LWT (Deg. F)	Entering Condenser Air Temperature (Degrees F)														
	75			85			95			105			115		
	Tons	kW	EER	Tons	kW	EER	Tons	kW	EER	Tons	kW	EER	Tons	kW	EER
40	62.9	48.7	14.0	59.5	53.4	12.2	56.0	58.7	10.5	52.3	64.7	9.0	48.6	71.2	7.6
42	65.1	49.4	14.3	61.6	54.1	12.4	58.0	59.4	10.8	54.3	65.4	9.2	50.4	71.9	7.9
44	67.3	50.1	14.6	63.7	54.8	12.7	60.1	60.1	11.0	56.2	66.1	9.5	52.3	72.7	8.1
46	69.5	50.8	14.9	65.9	55.5	13.0	62.1	60.8	11.3	58.2	66.8	9.7	54.2	73.5	8.3
48	71.8	51.5	15.2	68.1	56.2	13.3	64.2	61.5	11.5	60.3	67.6	9.9	56.1	74.3	8.5
50	74.2	52.2	15.5	70.4	56.9	13.6	66.4	62.3	11.8	62.3	68.4	10.2	58.1	75.2	8.7
55	80.1	54.0	16.2	76.1	58.7	14.3	71.9	64.1	12.4	67.5	70.4	10.7	63.0	77.5	9.2

Notes:

1. Ratings based on sea level altitude and evaporator fouling factor of 0.00010.
2. Consult Trane representative for performance at temperatures outside of the ranges shown.
3. kW input is for compressors only.
4. EER = Energy Efficiency Ratio (Btu/watt-hour). Power inputs include compressors, condenser fans and control power.
5. Ratings are based on an evaporator temperature drop of 10°F.
6. 115°F performance data reflects Adaptive Control Microprocessor control algorithms.
7. Interpolation between points is permissible. Extrapolation is not permitted.
8. Rated in accordance with ARI Standard 550/590-98.

Metric

LWT (Deg. C)	Entering Condenser Air Temperature (Degrees C)											
	30			35			40			45		
	kWo	kWi	COP	kWo	kWi	COP	kWo	kWi	COP	kWo	kWi	COP
6	218.3	54.9	3.6	206.7	59.7	3.2	194.8	65.0	2.8	182.8	70.9	2.4
8	232.1	56.1	3.8	220.1	61.0	3.3	207.4	66.3	2.9	194.8	72.3	2.5
10	246.1	57.4	3.9	233.5	62.3	3.5	220.5	67.7	3.0	207.1	73.8	2.6

Notes:

1. Ratings based on sea level altitude and evaporator fouling factor of 0.0176.
2. Consult Trane representative for performance at temperatures outside of the ranges shown.
3. kW input is for compressors only.
4. COP = Coefficient of Performance (kWo/kWi). Power inputs include compressors, condenser fans and control power.
5. Ratings are based on an evaporator temperature drop of 5.6°C.
6. 115°F performance data reflects Adaptive Control Microprocessor control algorithms.
7. Interpolation between points is permissible. Extrapolation is not permitted.
8. Rated in accordance with ARI Standard 550/590-98.

Table P-8 — 50 Hz RTAA 80 Performance Data
English

LWT (Deg. F)	Entering Condenser Air Temperature (Degrees F)														
	75			85			95			105			115		
	Tons	kW	EER	Tons	kW	EER	Tons	kW	EER	Tons	kW	EER	Tons	kW	EER
40	72.1	57.4	13.8	68.4	62.9	12.0	64.6	69.0	10.4	60.5	75.9	9.0	56.4	83.4	7.7
42	74.7	58.4	14.1	70.9	63.9	12.3	66.9	70.0	10.7	62.8	76.9	9.2	58.5	84.4	7.8
44	77.4	59.4	14.3	73.4	64.9	12.6	69.3	71.0	10.9	65.1	77.9	9.4	60.7	85.4	8.0
46	80.1	60.4	14.6	76.0	65.9	12.8	71.8	72.1	11.2	67.4	78.9	9.6	62.8	86.5	8.2
48	82.8	61.5	14.9	78.7	66.9	13.1	74.3	73.1	11.4	69.8	80.0	9.8	65.1	87.5	8.4
50	85.7	62.6	15.1	81.4	68.0	13.3	76.9	74.2	11.6	72.2	81.0	10.1	67.4	88.6	8.6
55	92.9	65.3	15.8	88.3	70.8	13.9	83.4	77.0	12.2	78.4	83.8	10.6	73.2	91.5	9.1

Notes:

1. Ratings based on sea level altitude and evaporator fouling factor of 0.00010.
2. Consult Trane representative for performance at temperatures outside of the ranges shown.
3. kW input is for compressors only.
4. EER = Energy Efficiency Ratio (Btu/watt-hour). Power inputs include compressors, condenser fans and control power.
5. Ratings are based on an evaporator temperature drop of 10°F.
6. 115°F performance data reflects Adaptive Control Microprocessor control algorithms.
7. Interpolation between points is permissible. Extrapolation is not permitted.
8. Rated in accordance with ARI Standard 550/590-98.

Metric

LWT (Deg. C)	Entering Condenser Air Temperature (Degrees C)											
	30			35			40			45		
	kWo	kWi	COP	kWo	kWi	COP	kWo	kWi	COP	kWo	kWi	COP
6	251.4	64.8	3.6	238.7	70.4	3.2	225.4	76.5	2.8	206.4	81.6	2.4
8	267.6	66.7	3.7	254.2	72.3	3.3	240.1	78.4	2.9	225.0	84.9	2.5
10	284.4	68.6	3.9	270.4	74.2	3.4	255.6	80.3	3.0	240.1	87.1	2.6

Notes:

1. Ratings based on sea level altitude and evaporator fouling factor of 0.0176.
2. Consult Trane representative for performance at temperatures outside of the ranges shown.
3. kW input is for compressors only.
4. COP = Coefficient of Performance (kWo/kWi). Power inputs include compressors, condenser fans and control power.
5. Ratings are based on an evaporator temperature drop of 5.6°C.
6. 115°F performance data reflects Adaptive Control Microprocessor control algorithms.
7. Interpolation between points is permissible. Extrapolation is not permitted.
8. Rated in accordance with ARI Standard 550/590-98.



Performance Data

Table P-9 — 50 Hz RTAA 90 Performance Data

English

LWT (Deg. F)	Entering Condenser Air Temperature (Degrees F)														
	75			85			95			105			115		
	Tons	kW	EER	Tons	kW	EER	Tons	kW	EER	Tons	kW	EER	Tons	kW	EER
40	82.1	68.1	13.3	78.0	73.9	11.7	73.5	80.6	10.2	68.9	88.1	8.8	64.0	96.6	7.5
42	85.0	69.3	13.5	80.7	75.1	12.0	76.1	81.7	10.4	71.3	89.3	9.0	66.3	97.7	7.7
44	87.9	70.5	13.8	83.5	76.3	12.2	78.8	82.9	10.7	73.8	90.5	9.2	68.7	98.9	7.9
46	90.9	71.8	14.0	86.3	77.5	12.4	81.5	84.1	10.9	76.4	91.7	9.4	71.1	100.2	8.1
48	93.9	73.1	14.3	89.2	78.8	12.6	84.2	85.4	11.1	79.0	92.9	9.6	73.5	101.4	8.2
50	97.0	74.4	14.5	92.1	80.1	12.9	87.0	86.7	11.3	81.6	94.2	9.8	76.0	102.7	8.4
55	105.0	77.8	15.0	99.7	83.4	13.4	94.2	90.0	11.8	88.3	97.5	10.3	79.9	103.0	8.8

- Notes:
1. Ratings based on sea level altitude and evaporator fouling factor of 0.00010.
 2. Consult Trane representative for performance at temperatures outside of the ranges shown.
 3. kW input is for compressors only.
 4. EER = Energy Efficiency Ratio (Btu/watt-hour). Power inputs include compressors, condenser fans and control power.
 5. Ratings are based on an evaporator temperature drop of 10°F.
 6. 115°F performance data reflects Adaptive Control Microprocessor control algorithms.
 7. Interpolation between points is permissible. Extrapolation is not permitted.
 8. Rated in accordance with ARI Standard 550/590-98.

Metric

LWT (Deg. C)	Entering Condenser Air Temperature (Degrees C)											
	30			35			40			45		
	kWo	kWi	COP	kWo	kWi	COP	kWo	kWi	COP	kWo	kWi	COP
6	286.2	76.2	3.5	271.4	82.2	3.1	256.0	89.0	2.7	240.1	96.5	2.4
8	303.8	78.4	3.6	288.3	84.4	3.2	272.1	91.1	2.8	255.6	98.6	2.5
10	322.1	80.7	3.7	305.9	86.7	3.3	289.0	93.4	2.9	271.1	100.9	2.5

- Notes:
1. Ratings based on sea level altitude and evaporator fouling factor of 0.0176.
 2. Consult Trane representative for performance at temperatures outside of the ranges shown.
 3. kWi input is for compressors only.
 4. COP = Coefficient of Performance (kWo/kWi). Power inputs include compressors, condenser fans and control power.
 5. Ratings are based on an evaporator temperature drop of 5.6°C.
 6. 115°F performance data reflects Adaptive Control Microprocessor control algorithms.
 7. Interpolation between points is permissible. Extrapolation is not permitted.
 8. Rated in accordance with ARI Standard 550/590-98.

Table P-10 — 50 Hz RTAA 100 Performance Data

English

LWT (Deg. F)	Entering Condenser Air Temperature (Degrees F)														
	75			85			95			105			115		
	Tons	kW	EER	Tons	kW	EER	Tons	kW	EER	Tons	kW	EER	Tons	kW	EER
40	91.1	78.4	12.9	86.6	84.6	11.4	81.7	91.7	10.0	76.5	100.0	8.6	71.0	109.4	7.4
42	94.2	79.8	13.1	89.5	85.9	11.6	84.5	93.1	10.2	79.1	101.3	8.8	73.5	110.7	7.5
44	97.4	81.2	13.3	92.5	87.3	11.8	87.3	94.4	10.4	81.8	102.7	9.0	76.0	112.1	7.7
46	100.6	82.7	13.5	95.6	88.7	12.0	90.2	95.8	10.6	84.5	104.1	9.2	78.6	113.5	7.9
48	103.9	84.2	13.7	98.7	90.2	12.3	93.2	97.3	10.8	87.3	105.5	9.4	81.2	114.9	8.0
50	107.3	85.7	13.9	101.9	91.7	12.5	96.2	98.7	11.0	90.1	106.9	9.6	83.8	116.3	8.2
55	115.9	89.7	14.4	110.1	95.6	12.9	103.9	102.6	11.4	97.4	110.7	10.0	88.6	117.6	8.6

- Notes:
1. Ratings based on sea level altitude and evaporator fouling factor of 0.00010.
 2. Consult Trane representative for performance at temperatures outside of the ranges shown.
 3. kW input is for compressors only.
 4. EER = Energy Efficiency Ratio (Btu/watt-hour). Power inputs include compressors, condenser fans and control power.
 5. Ratings are based on an evaporator temperature drop of 10°F.
 6. 115°F performance data reflects Adaptive Control Microprocessor control algorithms.
 7. Interpolation between points is permissible. Extrapolation is not permitted.
 8. Rated in accordance with ARI Standard 550/590-98.

Metric

LWT (Deg. C)	Entering Condenser Air Temperature (Degrees C)											
	30			35			40			45		
	kWo	kWi	COP	kWo	kWi	COP	kWo	kWi	COP	kWo	kWi	COP
6	317.1	87.1	3.4	301.0	100.0	3.0	283.7	101.0	2.6	265.8	109.3	2.3
8	336.5	89.7	3.5	319.3	102.5	3.1	301.3	103.5	2.7	282.3	111.8	2.4
10	356.2	92.3	3.6	338.2	105.1	3.2	319.3	106.1	2.8	299.2	114.4	2.5

- Notes:
1. Ratings based on sea level altitude and evaporator fouling factor of 0.0176.
 2. Consult Trane representative for performance at temperatures outside of the ranges shown.
 3. kWi input is for compressors only.
 4. COP = Coefficient of Performance (kWo/kWi). Power inputs include compressors, condenser fans and control power.
 5. Ratings are based on an evaporator temperature drop of 5.6°C.
 6. 115°F performance data reflects Adaptive Control Microprocessor control algorithms.
 7. Interpolation between points is permissible. Extrapolation is not permitted.
 8. Rated in accordance with ARI Standard 550/590-98.

Performance Data

Table P-11 — 50 Hz RTAA 110 Performance Data
English

LWT (Deg. F)	Entering Condenser Air Temperature (Degrees F)														
	75			85			95			105			115		
	Tons	kW	EER	Tons	kW	EER	Tons	kW	EER	Tons	kW	EER	Tons	kW	EER
40	98.4	85.3	12.8	93.5	92.0	11.4	88.2	99.9	10.0	82.6	108.9	8.6	76.7	119.1	7.3
42	101.7	86.8	13.1	96.7	93.5	11.6	91.2	101.3	10.2	85.5	110.3	8.8	79.4	120.6	7.5
44	105.1	88.3	13.3	99.9	95.0	11.8	94.3	102.8	10.4	88.3	111.8	9.0	82.1	122.1	7.7
46	108.5	89.9	13.5	103.1	96.5	12.0	97.4	104.3	10.6	91.3	113.3	9.2	84.9	123.6	7.8
48	112.1	91.5	13.7	106.5	98.1	12.2	100.5	105.9	10.7	94.3	114.9	9.3	87.7	125.2	8.0
50	115.6	93.2	13.9	109.9	99.7	12.4	103.8	107.5	10.9	97.3	116.5	9.5	90.5	126.7	8.2
55	124.8	97.5	14.4	118.6	103.9	12.9	112.0	111.6	11.4	105.0	120.5	9.9	92.3	123.5	8.5

Notes:

1. Ratings based on sea level altitude and evaporator fouling factor of 0.00010.
2. Consult Trane representative for performance at temperatures outside of the ranges shown.
3. kW input is for compressors only.
4. EER = Energy Efficiency Ratio (Btu/watt-hour). Power inputs include compressors, condenser fans and control power.
5. Ratings are based on an evaporator temperature drop of 10°F.
6. 115°F performance data reflects Adaptive Control Microprocessor control algorithms.
7. Interpolation between points is permissible. Extrapolation is not permitted.
8. Rated in accordance with ARI Standard 550/590-98.

Metric

LWT (Deg. C)	Entering Condenser Air Temperature (Degrees C)											
	30			35			40			45		
	kWo	kWi	COP	kWo	kWi	COP	kWo	kWi	COP	kWo	kWi	COP
6	342.5	94.8	3.4	324.9	101.9	3.0	306.6	110.0	2.6	287.3	119.0	2.3
8	362.9	97.5	3.5	344.6	104.6	3.1	325.2	112.7	2.7	304.8	121.8	2.4
10	384.3	100.4	3.6	365.0	107.5	3.2	344.6	115.5	2.8	323.1	124.6	2.5

1. Ratings based on sea level altitude and evaporator fouling factor of 0.0176.
2. Consult Trane representative for performance at temperatures outside of the ranges shown.
3. kW input is for compressors only.
4. COP = Coefficient of Performance (kWo/kWi). Power inputs include compressors, condenser fans and control power.
5. Ratings are based on an evaporator temperature drop of 5.6°C.
6. 115°F performance data reflects Adaptive Control Microprocessor control algorithms.
7. Interpolation between points is permissible. Extrapolation is not permitted.
8. Rated in accordance with ARI Standard 550/590-98.

Table P-12 — 50 Hz RTAA 125 Performance Data
English

LWT (Deg. F)	Entering Condenser Air Temperature (Degrees F)														
	75			85			95			105			115		
	Tons	kW	EER	Tons	kW	EER	Tons	kW	EER	Tons	kW	EER	Tons	kW	EER
40	108.8	93.9	13.0	103.2	101.2	11.5	97.3	109.7	10.1	91.0	119.4	8.7	84.4	130.5	7.4
42	112.5	95.6	13.2	106.7	102.8	11.7	100.6	111.3	10.3	94.1	121.1	8.9	87.3	132.2	7.6
44	116.2	97.3	13.4	110.3	104.5	11.9	104.0	113.0	10.5	97.3	122.7	9.1	90.3	133.8	7.7
46	120.0	99.1	13.6	113.9	106.2	12.1	107.4	114.7	10.6	100.5	124.5	9.2	93.4	135.6	7.9
48	123.9	100.9	13.8	117.6	108.0	12.3	110.9	116.5	10.8	103.8	126.2	9.4	95.8	136.5	8.1
50	127.9	102.8	14.0	121.4	109.9	12.5	114.4	118.3	11.0	107.1	128.0	9.6	96.5	135.1	8.2
55	138.1	107.7	14.5	131.0	114.7	13.0	123.5	123.0	11.5	115.6	132.6	10.0	97.7	129.8	8.6

Notes:

1. Ratings based on sea level altitude and evaporator fouling factor of 0.00010.
2. Consult Trane representative for performance at temperatures outside of the ranges shown.
3. kW input is for compressors only.
4. EER = Energy Efficiency Ratio (Btu/watt-hour). Power inputs include compressors, condenser fans and control power.
5. Ratings are based on an evaporator temperature drop of 10°F.
6. 115°F performance data reflects Adaptive Control Microprocessor control algorithms.
7. Interpolation between points is permissible. Extrapolation is not permitted.
8. Rated in accordance with ARI Standard 550/590-98.

Metric

LWT (Deg. C)	Entering Condenser Air Temperature (Degrees C)											
	30			35			40			45		
	kWo	kWi	COP	kWo	kWi	COP	kWo	kWi	COP	kWo	kWi	COP
6	378.3	104.3	3.4	358.6	112.0	3.0	337.9	120.7	2.7	316.1	130.5	2.3
8	400.8	107.4	3.5	380.1	115.0	3.1	358.3	123.8	2.8	335.4	133.6	2.4
10	424.4	110.7	3.6	402.6	118.3	3.2	379.4	127.0	2.9	355.5	136.7	2.5

Notes:

1. Ratings based on sea level altitude and evaporator fouling factor of 0.0176.
2. Consult Trane representative for performance at temperatures outside of the ranges shown.
3. kW input is for compressors only.
4. COP = Coefficient of Performance (kWo/kWi). Power inputs include compressors, condenser fans and control power.
5. Ratings are based on an evaporator temperature drop of 5.6°C.
6. 115°F performance data reflects Adaptive Control Microprocessor control algorithms.
7. Interpolation between points is permissible. Extrapolation is not permitted.
8. Rated in accordance with ARI Standard 550/590-98.



Performance Data

Table P-13 — ARI Part-Load Values (60 Hz)

Unit	% Load	Tons	EER	IPLV
RTAA 70	100	69.3	10.2	13.6
	75	51.9	12.0	
	50	34.6	14.6	
	25	17.3	16.1	
RTAA 80	100	79.8	10.2	13.2
	75	59.8	11.7	
	50	39.8	14.9	
	25	19.9	12.6	
RTAA 90	100	90.8	9.9	12.6
	75	68.0	11.3	
	50	45.3	13.5	
	25	22.7	13.6	
RTAA 100	100	100.6	9.7	12.6
	75	75.5	11.0	
	50	50.3	13.5	
	25	25.2	14.8	
RTAA 110	100	108.5	9.7	12.6
	75	81.2	11.0	
	50	54.2	13.7	
	25	27.1	14.8	
RTAA125	100	120.1	9.8	12.6
	75	89.7	11.2	
	50	59.8	13.7	
	25	29.9	13.4	

Table P-14 — ARI Part-Load Values (50 Hz)

Unit	% Load	Tons	EER	IPLV
RTAA 70	100	60.1	11.0	15.0
	75	45.0	13.2	
	50	30.0	15.9	
	25	15.0	17.9	
RTAA 80	100	69.3	10.9	14.5
	75	52.0	12.8	
	50	34.7	16.3	
	25	17.3	13.8	
RTAA 90	100	78.8	10.7	13.8
	75	59.1	12.4	
	50	39.4	14.8	
	25	19.7	15.0	
RTAA 100	100	87.3	10.4	13.7
	75	65.5	12.0	
	50	43.7	14.6	
	25	21.8	16.0	
RTAA 110	100	94.3	10.4	13.8
	75	70.7	12.0	
	50	47.1	14.8	
	25	23.6	16.6	
RTAA125	100	104.0	10.5	13.7
	75	78.0	12.1	
	50	52.0	14.8	
	25	26.0	15.3	

Electrical Data

Table E-1 — Electrical Data (50 & 60 Hz, 3 Phase)

Unit Size	Unit Wiring						Motor Data					
	Rated Voltage (9)	# of Power Connections (1)	MCA (3)	Max. Fuse, HACR Breaker or MOP (2,11)	Rec. Time Delay or RDE (4)	Qty	Compressor (Each)		Qty.	Fans (Each)		Control kW (7, 10)
							RLA (5)	LRA (8)		kW	FLA	
RTAA 70	200/60	1	300	400	350	2	115 - 115	800 - 800	8	1.0	5.1	0.75
	230/60	1	265	350	300	2	100 - 100	690 - 690	8	1.0	5.0	0.75
	380/60	1	163	200	200	2	61 - 61	400 - 400	8	1.0	3.2	0.75
	460/60	1	133	175	150	2	50 - 50	330 - 330	8	1.0	2.5	0.75
	575/60	1	108	125	125	2	40 - 40	270 - 270	8	1.0	2.2	0.75
	380/50	1	140	175	150	2	53 - 53	308 - 308	8	0.7	2.5	0.75
	400/50	1	133	175	150	2	50 - 50	325 - 325	8	0.7	2.5	0.75
415/50	1	128	175	150	2	48 - 48	337 - 337	8	0.7	2.5	0.75	
RTAA 80	200/60	1	361	500	400	2	142 - 142	800 - 800	8	1.0	5.1	0.75
	230/60	1	319	400	350	2	124 - 124	760 - 760	8	1.0	5.0	0.75
	380/60	1	194	250	225	2	75 - 75	465 - 465	8	1.0	3.2	0.75
	460/60	1	160	200	175	2	62 - 62	380 - 380	8	1.0	2.5	0.75
	575/60	1	131	175	150	2	50 - 50	304 - 304	8	1.0	2.2	0.75
	380/50	1	167	200	175	2	65 - 65	356 - 356	8	0.7	2.5	0.75
	400/50	1	160	200	175	2	62 - 62	375 - 375	8	0.7	2.5	0.75
415/50	1	155	200	175	2	60 - 60	389 - 389	8	0.7	2.5	0.75	
RTAA 90	200/60	1	428	600	500	2	192 - 142	990 - 800	9	1.0	5.1	0.75
	230/60	1	378	500	450	2	167 - 124	820 - 760	9	1.0	5.0	0.75
	380/60	1	230	300	300	2	101 - 75	497 - 465	9	1.0	3.2	0.75
	460/60	1	190	250	225	2	84 - 62	410 - 380	9	1.0	2.5	0.75
	575/60	1	154	200	175	2	67 - 50	328 - 304	9	1.0	2.2	0.75
	380/50	1	195	250	225	2	88 - 65	386 - 356	9	0.7	2.5	0.75
	400/50	1	190	250	225	2	84 - 62	402 - 375	9	0.7	2.5	0.75
415/50	1	182	250	225	2	81 - 60	417 - 389	9	0.7	2.5	0.75	
RTAA 100	200/60	1	483	600	600	2	192 - 192	990 - 990	10	1.0	5.1	0.75
	230/60	1	426	500	500	2	167 - 167	820 - 820	10	1.0	5.0	0.75
	380/60	1	259	350	300	2	101 - 101	497 - 497	10	1.0	3.2	0.75
	460/60	1	214	250	250	2	84 - 84	410 - 410	10	1.0	2.5	0.75
	575/60	1	173	225	200	2	67 - 67	328 - 328	10	1.0	2.2	0.75
	380/50	1	223	250	250	2	88 - 88	382 - 382	10	0.7	2.5	0.75
	400/50	1	214	250	250	2	84 - 84	402 - 402	10	0.7	2.5	0.75
415/50	1	208	250	250	2	81 - 81	417 - 417	10	0.7	2.5	0.75	
RTAA 110	200/60	1	535	700	600	2	233 - 192	1190 - 990	10	1.0	5.1	0.75
	230/60	1	471	600	600	2	203 - 167	1044 - 820	10	1.0	5.0	0.75
	380/60	1	287	400	350	2	123 - 101	632 - 497	10	1.0	3.2	0.75
	460/60	1	235	300	300	2	101 - 84	522 - 410	10	1.0	2.5	0.75
	575/60	1	191	250	225	2	81 - 67	420 - 328	10	1.0	2.2	0.75
	380/50	1	245	300	300	2	106 - 88	487 - 382	10	0.7	2.5	0.75
	400/50	1	236	300	300	2	101 - 84	512 - 402	10	0.7	2.5	0.75
415/50	1	228	300	300	2	97 - 81	531 - 417	10	0.7	2.5	0.75	
RTAA 125	200/60	1	576	800	700	2	233 - 233	1190 - 1190	10	1.0	5.1	0.75
	230/60	1	507	700	600	2	203 - 203	1044 - 1044	10	1.0	5.0	0.75
	380/60	1	309	400	350	2	123 - 123	632 - 632	10	1.0	3.2	0.75
	460/60	1	253	350	300	2	101 - 101	522 - 522	10	1.0	2.5	0.75
	575/60	1	205	250	225	2	81 - 81	420 - 420	10	1.0	2.2	0.75
	380/50	1	264	350	300	2	106 - 106	487 - 487	10	0.7	2.5	0.75
	400/50	1	253	350	300	2	101 - 101	512 - 512	10	0.7	2.5	0.75
415/50	1	244	350	300	2	97 - 97	531 - 531	10	0.7	2.5	0.75	

Notes:

- As standard, all 70-215 ton units require a single point power connection.
- Max Fuse or HACR type breaker = 225 percent of the largest compressor RLA plus 100 percent of the second compressor RLA, plus the sum of the condenser fan FLA per NEC 440-22. Use FLA per circuit, NOT FLA for the entire unit).
- MCA - Minimum Circuit Ampacity - 125 percent of largest compressor RLA plus 100 percent of the second compressor RLA plus the sum of the condenser fans FLAs per NEC 440-33.
- RECOMMENDED TIME DELAY OR DUAL ELEMENT (RDE) FUSE SIZE: 150 percent of the largest compressor RLA plus 100 percent of the second compressor RLA and the sum of the condenser fan FLAs.
- RLA - Rated Load Amps - rated in accordance with UL Standard 1995.
- Local codes may take precedence.
- Control kW includes operational controls only. Does not include evaporator heat tape.
- LRA - Locked Rotor Amps - based on full winding (x-line) start units. LRA for wye-delta starters is 1/3 of LRA of x-line units.
- VOLTAGE UTILIZATION RANGE:

Rated Voltage	Utilization Range
200	180-220
230	208-254
380	342-418
460	414-506
575	516-633
- A 115/60/1, 15 amp customer provided power connection is required to operate the unit controls. A separate 115/60/1, 15 amp customer provided power connection is also needed to power the evaporator heat tape (420 watts @ 120 volts). If the optional control power transformer is used, the customer needs only to provide a power connection for the evaporator heat tape.
- If factory circuit breakers are supplied with the chiller, then these values represent Maximum Overcurrent Protection (MOP).



Jobsite Connections

Table J-1 – Customer Wire Selection

Unit Size	Rated Voltage	Wire Selection Size to Main Terminal Block		Wire Selection Size to Disconnect (1)		Wire Selection Size to Circuit Breaker (1)	
		Terminal Size Ckt 1	Connector Wire Range Ckt 1	Disconnect Size Ckt 1	Connector Wire Range Ckt 1	Factory Mounted Internal Circuit Breaker Size (3) Ckt 1	Connector Wire Range Ckt 1
RTAA 70	200/60	760 Amp	Lug Size D	400 Amp	Lug Size B	350 Amp	Lug Size B
	230/60	760 Amp	Lug Size D	400 Amp	Lug Size B	300 Amp	Lug Size B
	380/60	335 Amp	Lug Size E	250 Amp	Lug Size A	200 Amp	Lug Size A
	460/60	335 Amp	Lug Size E	250 Amp	Lug Size A	150 Amp	Lug Size A
	575/60	335 Amp	Lug Size E	250 Amp	Lug Size A	125 Amp	Lug Size A
	380/50	335 Amp	Lug Size E	250 Amp	Lug Size A	150 Amp	Lug Size A
	400/50	335 Amp	Lug Size E	250 Amp	Lug Size A	150 Amp	Lug Size A
	415/50	335 Amp	Lug Size E	250 Amp	Lug Size A	150 Amp	Lug Size A
RTAA 80	200/60	760 Amp	Lug Size D	400 Amp	Lug Size B	400 Amp	Lug Size B
	230/60	760 Amp	Lug Size D	400 Amp	Lug Size B	350 Amp	Lug Size B
	380/60	335 Amp	Lug Size E	250 Amp	Lug Size A	225 Amp	Lug Size A
	460/60	335 Amp	Lug Size E	250 Amp	Lug Size A	175 Amp	Lug Size A
	575/60	335 Amp	Lug Size E	250 Amp	Lug Size A	150 Amp	Lug Size A
	380/50	335 Amp	Lug Size E	250 Amp	Lug Size A	175 Amp	Lug Size A
	400/50	335 Amp	Lug Size E	250 Amp	Lug Size A	175 Amp	Lug Size A
	415/50	335 Amp	Lug Size E	250 Amp	Lug Size A	175 Amp	Lug Size A
RTAA 90	200/60	760 Amp	Lug Size D	600 Amp	Lug Size C	500 Amp	Lug Size C
	230/60	760 Amp	Lug Size D	400 Amp	Lug Size B	450 Amp	Lug Size C
	380/60	335 Amp	Lug Size E	400 Amp	Lug Size B	300 Amp	Lug Size B
	460/60	335 Amp	Lug Size E	250 Amp	Lug Size A	225 Amp	Lug Size A
	575/60	335 Amp	Lug Size E	250 Amp	Lug Size A	175 Amp	Lug Size A
	380/50	335 Amp	Lug Size E	250 Amp	Lug Size A	225 Amp	Lug Size A
	400/50	335 Amp	Lug Size E	250 Amp	Lug Size A	225 Amp	Lug Size A
	415/50	335 Amp	Lug Size E	250 Amp	Lug Size A	225 Amp	Lug Size A
RTAA 100	200/60	760 Amp	Lug Size D	600 Amp	Lug Size C	600 Amp	Lug Size C
	230/60	760 Amp	Lug Size D	600 Amp	Lug Size C	500 Amp	Lug Size C
	380/60	335 Amp	Lug Size E	400 Amp	Lug Size B	300 Amp	Lug Size B
	460/60	335 Amp	Lug Size E	250 Amp	Lug Size A	250 Amp	Lug Size A
	575/60	335 Amp	Lug Size E	250 Amp	Lug Size A	200 Amp	Lug Size A
	380/50	335 Amp	Lug Size E	250 Amp	Lug Size A	250 Amp	Lug Size A
	400/50	335 Amp	Lug Size E	250 Amp	Lug Size A	250 Amp	Lug Size A
	415/50	335 Amp	Lug Size E	250 Amp	Lug Size A	250 Amp	Lug Size A
RTAA 110	200/60	760 Amp	Lug Size D	600 Amp	Lug Size C	600 Amp	Lug Size C
	230/60	760 Amp	Lug Size D	600 Amp	Lug Size C	600 Amp	Lug Size C
	380/60	335 Amp	Lug Size E	400 Amp	Lug Size B	350 Amp	Lug Size B
	460/60	335 Amp	Lug Size E	400 Amp	Lug Size B	300 Amp	Lug Size B
	575/60	335 Amp	Lug Size E	250 Amp	Lug Size A	225 Amp	Lug Size A
	380/50	335 Amp	Lug Size E	400 Amp	Lug Size B	300 Amp	Lug Size B
	400/50	335 Amp	Lug Size E	400 Amp	Lug Size B	300 Amp	Lug Size B
	415/50	335 Amp	Lug Size E	400 Amp	Lug Size B	300 Amp	Lug Size B
RTAA 125	200/60	760 Amp	Lug Size D	600 Amp	Lug Size C	N/A	N/A
	230/60	760 Amp	Lug Size D	600 Amp	Lug Size C	600 Amp	Lug Size C
	380/60	335 Amp	Lug Size E	400 Amp	Lug Size B	350 Amp	Lug Size B
	460/60	335 Amp	Lug Size E	400 Amp	Lug Size B	300 Amp	Lug Size B
	575/60	335 Amp	Lug Size E	250 Amp	Lug Size A	225 Amp	Lug Size A
	380/50	335 Amp	Lug Size E	400 Amp	Lug Size B	300 Amp	Lug Size B
	400/50	335 Amp	Lug Size E	400 Amp	Lug Size B	300 Amp	Lug Size B
	415/50	335 Amp	Lug Size E	400 Amp	Lug Size B	300 Amp	Lug Size B

Lug Size A = #4 to 350 MCM per phase
 Lug Size B = 2/0 to 250 MCM & 2/0 to 500 MCM per phase
 Lug Size C = (2) 400 MCM to 500 MCM per phase
 Lug Size D = (2) #4 to 500 MCM per phase
 Lug Size E = #6 to 400 MCM per phase
 Lug Size F = (2) #2 to 600 MCM per phase
 Lug Size G = (2) #1 to 500 MCM per phase
 Lug Size H = (4) #2 to 600 MCM per phase

Notes

1. Non-fused unit disconnect and circuit breaker are optional.
2. Copper wire only, sized per N.E.C., based on nameplate minimum circuit ampacity (MCA).
3. Circuit Breaker sizes are for factory mounted only. Field installed circuit breakers need to be sized using HACR breaker recommendations from Table E-1.

Jobsite Connections

Figure J-1 — Typical Jobsite Wiring

NOTES:

- DASHED LINES INDICATE RECOMMENDED FIELD WIRING BY OTHERS. CHECK SALES ORDER TO DETERMINE IF WIRING IS REQUIRED FOR SPECIFIC OPTIONS.
- ALL THREE PHASE MOTORS SUPPLIED WITH THE UNIT ARE PROTECTED UNDER PRIMARY SINGLE PHASE FAILURE CONDITIONS.
- CAUTION - DO NOT ENERGIZE UNIT UNTIL CHECK OUT AND START-UP PROCEDURES HAVE BEEN COMPLETED.
- THE FOLLOWING CAPABILITIES ARE OPTIONAL - THEY ARE IMPLEMENTED AND WIRED AS REQUIRED FOR A SPECIFIC SYSTEM APPLICATION.

- A** ICE-MACHINE CONTROL (CANNOT BE USED WITH OPT. L)
- B** COMMUNICATIONS INTERFACE
- D** WYE-DELTA CLOSED TRANSITION STARTER
- E** CONTROL POWER TRANSFORMER.
- H** UNIT DISCONNECT, NON-FUSED
- J** CHILLED WATER RESET - RETURN WATER
- K** CHILLED WATER RESET - OUTDOOR AIR
- L** CHILLED WATER RESET - ZONE AIR (CANNOT BE USED WITH OPT. A)
- S** CHILLED WATER FLOW SWITCH (NOT REQUIRED FOR CHILLER PROTECTION)
- T** REMOTE CLEAR LANGUAGE DISPLAY.
(BUFFER FOR DISPLAY LOCATED IN UNIT CONTROL PANEL.)

- 5** AUXILIARY CONTROLS FOR A CUSTOMER SPECIFIED OR INSTALLED LATCHING TRIP/OUT. THE CHILLER WILL RUN NORMALLY WHEN THE CONTACT IS CLOSED AND TRIP THE CHILLER OFF ON MANUALLY RESETTABLE DIAGNOSTIC WHEN THE CONTACT OPENS. MANUAL RESET IS ACCOMPLISHED AT THE LOCAL OR REMOTE CLEAR LANGUAGE DISPLAY.
- 6** AUXILIARY CONTROLS FOR A CUSTOMER SPECIFIED OR INSTALLED REMOTE AUTO/ STOP FUNCTION. THE CHILLER WILL RUN NORMALLY WHEN THE CONTACT IS CLOSED AND STOP THE CHILLER WHEN THE CONTACT IS OPEN. RE-CLOSURE OF THE CONTACT WILL PERMIT THE CHILLER TO AUTOMATICALLY RETURN TO NORMAL OPERATION. TO BE IN SERIES WITH WATER PUMP RELAY (3K21).
- 7** NORMALLY OPEN CONTACTS FOR REMOTE SHUTDOWN OR REFRIGERANT CIRCUIT OPERATION. THE REFRIGERANT CIRCUIT WILL GO THRU A NORMAL SHUTDOWN WHEN THE CONTACTS ARE CLOSED AND WILL AUTOMATICALLY RESUME NORMAL START AND RUN MODES WHEN CONTACTS ARE OPEN.

WIRING

- 8** ALL CUSTOMER CONTROL CIRCUIT WIRING MUST HAVE A MINIMUM RATING OF 150 VOLTS.
- 9** ALL FIELD WIRING MUST BE IN ACCORDANCE WITH THE NATIONAL ELECTRICAL CODE (NEC), STATE, AND LOCAL REQUIREMENTS. OUTSIDE THE UNITED STATES, OTHER COUNTRIES APPLICABLE NATIONAL AND/OR LOCAL REQUIREMENTS SHALL APPLY.

REQUIRED WIRING

- 10** COPPER WIRE ONLY - SIZED PER N.E.C. - BASED ON NAMEPLATE MINIMUM CIRCUIT AMPACITY (MCA). SEE CUSTOMER WIRE SELECTION TABLE.
- 11** 2 WIRES, 115 VAC CIRCUIT. MINIMUM CONTACT RATING AT 115 VAC - 5.9 VA INRUSH. 1.3 VA SEALED.
- 12** FOR UNITS WITHOUT THE CONTROL POWER TRANSFORMER (1T1) OPTION, THE CUSTOMER MUST PROVIDE CONTROL POWER OF 115 VAC, 60 HERTZ, SINGLE PHASE, 750 VA. THE CONTROL POWER TRANSFORMER (1T1) IS STANDARD ON 50 HERTZ UNITS.
- 13** FOR ALL UNITS, THE HEAT TAPE MUST BE POWERED FROM A SEPARATE CUSTOMER PROVIDED 115V, 60 HZ; OR 220V, 50 HZ, 420 WATT SOURCE.

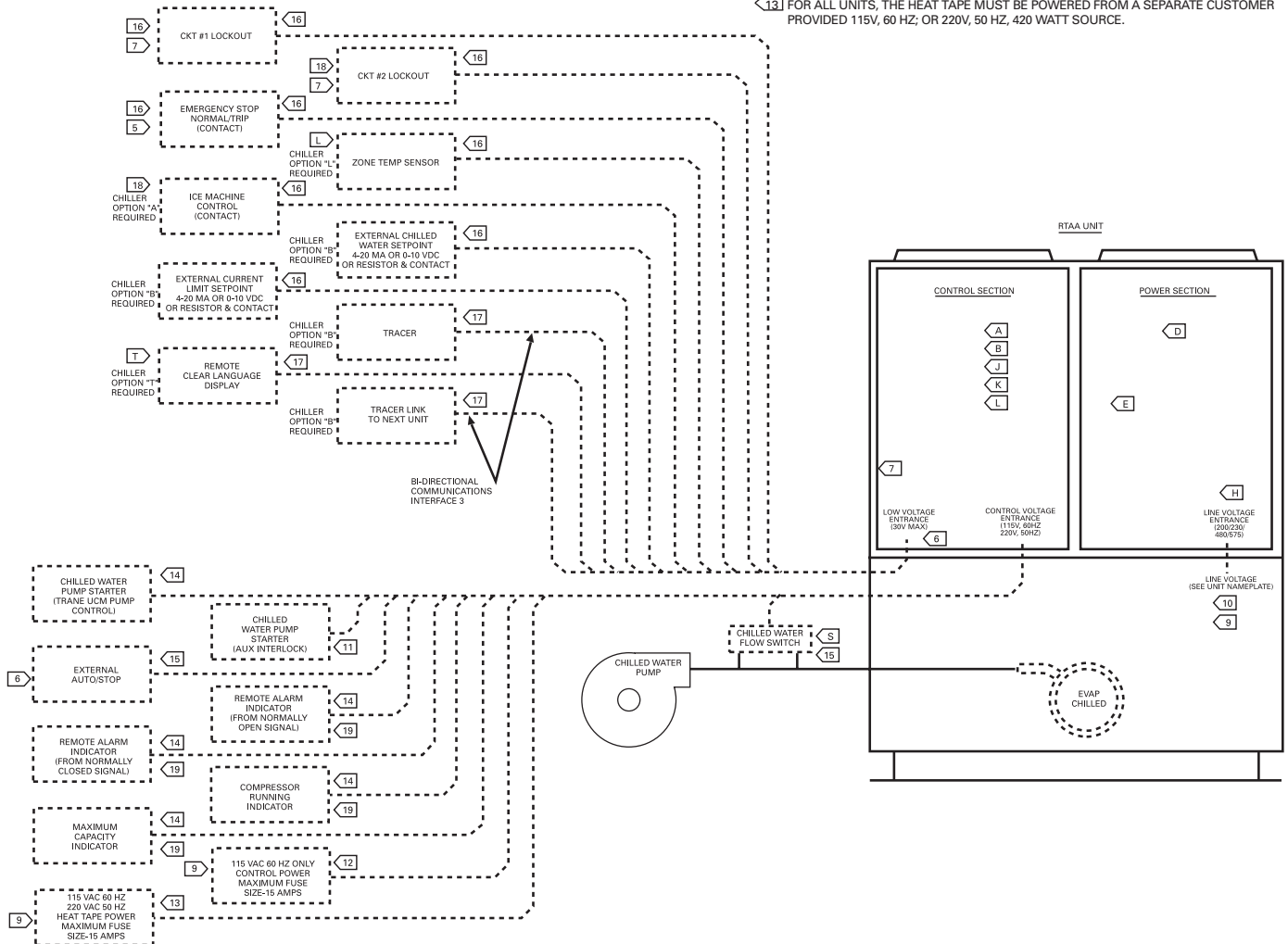

Controls

Microcomputer Controls

A microcomputer-based controller controls the air-cooled Series R™ 70-125 ton chiller. The microcomputer controller provides better control than past controls as well as several new, important benefits.

Adaptive Control™ Microprocessor

The microcomputer-based controller allows Trane to optimize controls around the chiller application and the specific components used in the air-cooled Series R™ chiller. For instance, the compressor protection system is specifically designed for the air-cooled

Series R™ chiller. A new leaving chilled water temperature control algorithm maintains accurate temperature control, minimizes the drift from setpoint and provides better building comfort. This control, combined with linear compressor unloading, also allows the chiller to be applied in wider array of applications, including variable primary flow. The microcomputer control incorporates improved chiller start-up, load limiting, lead/lag, and compressor run time equalization functions into standard chiller operation. Interface with outside systems such as building automation controls is flexible and easy.



Controls

Simple Interface With Other Control Systems

Microcomputer controls afford simple interface with other control systems, such as time clocks, building automation systems and ice storage systems. Wiring to the unit can be as simple as two wires! This means you can have the flexibility to meet job requirements while not having to learn a complicated control system.

Safety Controls

A centralized microcomputer offers a higher level of machine protection. Since the safety controls are smarter, they limit compressor loading to avoid compressor or evaporator failures, thereby minimizing nuisance shutdown. The Unit Control Module (UCM) directly senses the control variables that govern the loading of the chiller: motor current draw, evaporator temperature, condenser temperature, etc. When any one of the variables approaches a limit condition where the unit may be damaged or shutdown on a safety, the UCM takes corrective action to avoid shutdown and keep the chiller operating. It does this through combined actions of compressor slide valve modulation, electronic expansion valve modulation and fan staging. The UCM optimizes total chiller power consumption during normal operating conditions. During abnormal operating conditions, the UCM will continue to optimize chiller performance by taking the corrective action necessary to avoid shutdown. This keeps cooling capacity available until the problem can be solved.

Whenever possible, the chiller is allowed to perform its function; make chilled water. In addition, microcomputer controls allow for more types of protection such as over and under voltage. Overall, the safety controls help keep the building running and out of trouble.

Monitoring And Diagnostics

Since the microcomputer provides all control functions, it can easily indicate such parameters as leaving chilled water temperature and capacity stage. If a failure does occur, one of over 90 individual diagnostic and operating codes will be used to indicate the problem, giving more specific information about the failure. All of the monitoring and diagnostic information is displayed directly on a microcomputer display.

Interface With The Trane Integrated Comfort™ System (ICS)

When the air-cooled Series R™ chiller is used in conjunction with a Trane Tracer™ system, the unit can be monitored and controlled from a remote location. The air-cooled Series R™ chiller can be controlled to fit into the overall building automation strategy by using time of day scheduling, timed override, duty cycling, demand limiting, and chiller sequencing. A building owner can completely monitor the air-cooled Series R™ chiller from the Tracer system, as all of the monitoring information indicated on the microcomputer can be read off the Tracer system display. In addition, all the powerful diagnostic information can be read back at the Tracer system. Best of all, this powerful capability comes over a single twisted pair of wires!

Air-cooled Series R™ chillers can interface with many different external control systems, from simple stand-alone units to ice making systems. Each unit requires a single-source, three-phase power supply and two 115-volt power supplies. When an optional control power transformer is used, a single 115-volt supply handles the evaporator heat tape. For basic stand-alone applications, the interface with outside control is no different than for other Trane chillers. However, the RTAA units have many features that can be used to interface with building control systems.

Standard Features

1. External Auto/Stop

A jobsite provided contact closure will turn the unit on and off.

Note: Do not use the chilled water pump to stop the chiller.

2. Chilled Waterflow Interlock

A jobsite provided contact closure from a chilled water pump contactor or a flow switch is required and will allow unit operation if a load exists. This feature will allow the unit to run in conjunction with the pump system.

3. External Interlock

A jobsite supplied contact opening wired to this input will turn the unit off and require a manual reset of the unit microcomputer. This closure is typically triggered by a jobsite supplied system such as a fire alarm.

4. Chilled Water Pump Control

Unit controls provide an output to control chilled water pump(s). One contact closure to the chiller is all that is required to initiate the chilled water system.

5. Remote Running and Alarm Indication Contacts

The unit provides three single-pole/double-throw contact closures to indicate that a failure has occurred, if any compressors are running, or if the compressors are running at maximum capacity. These contact closures may be used to trigger jobsite supplied alarm lights or alarm bells.

Controls

Optional Features

1. Communication Interface

Capability for communication with one of the following control devices:

a
Trane Tracer™ Building Automation Systems

b
Remote Display

2. External Chilled Water Setpoint

Allows the external setting independent of the front panel setpoint by one of three means:

a) a remote resistor input (fixed or adjustable), b) a 2-10 VDC input, or c) a 4-20 mA input.

3. External Current Limit Setpoint

Allows the external setting independent of the front panel set point by one of three means:

a) a remote resistor input (fixed or adjustable), b) a 2-10 VDC input, or c) a 4-20 mA input.

4. Ice Making Control

Provides interface with ice making control systems.

5. Chilled Water Temperature Reset

Reset can be based on return water temperature or outdoor air temperature. The next section reviews the recommended interface with the following control systems:

Stand-Alone Unit

Integrated Comfort™ System Interface

Non-Trane Building Automation Systems

Ice Making Systems

Remote Display

Each system description includes a list of those features which must be used, those features which can be used and which external Trane device is required.



Controls

Trane Controls System

Tracer Summit controls — Interface With The Trane Integrated Comfort System (ICS)

Trane Chiller Plant Control

The Tracer Summit Chiller Plant Building Management System with Chiller Plant Control provides building automation and energy management functions through stand-alone control. The Chiller Plant Control is capable of monitoring and controlling your entire chiller plant system.

Application software available:

- Time-of-day scheduling
- Demand limiting
- Chiller sequencing
- Process control language
- Boolean processing
- Zone control
- Reports and logs
- Custom messages
- Run time and maintenance
- Trend log
- PID control loops

And of course, the Trane Chiller Plant Control can be used on a stand-alone basis or tied into a complete building automation system.

When the air-cooled Series R™ 70-125 ton chiller is used in conjunction with a Trane Tracer™ Summit system, the unit can be monitored and controlled from a remote location. The air-cooled Series R™ 70-125 ton chiller can be controlled to fit into the overall building automation strategy by using time of day scheduling, timed override, demand limiting, and chiller sequencing. A building owner can completely monitor the air-cooled Series R™ 70-125 ton chiller from the Tracer system, since all of the monitoring information indicated on the unit controller's microcomputer can be read off the Tracer system display. In addition, all the powerful diagnostic information can be read back at the Tracer system. Best of all, this powerful capability comes over a single twisted pair of wires! Air-

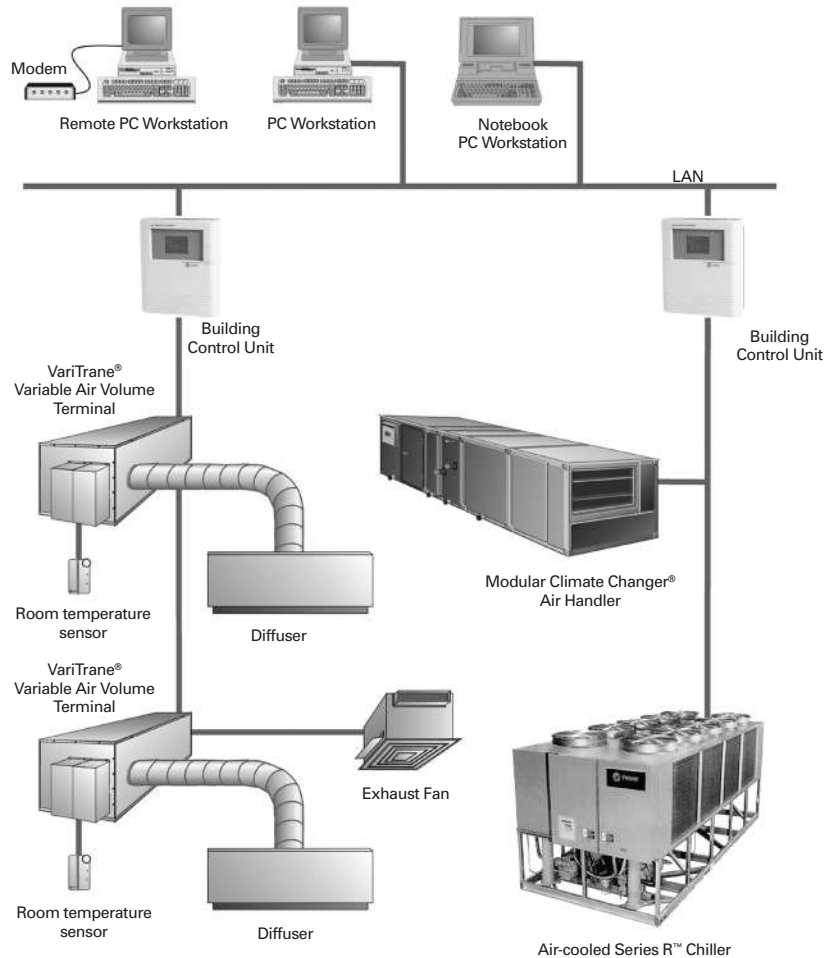

cooled Series R™ 70-125 ton chillers can interface with many different external control systems, from simple stand-alone units to ice making systems. Each unit requires a single-source, three-phase power supply and a 115V/60Hz, 220V/50Hz power supply. The added power supply powers the evaporator heaters.

A single twisted pair of wires tied directly between the air-cooled Series R™ 70-125 ton chiller and a Tracer™ Summit system provides control, monitoring and diagnostic capabilities. Control functions

include auto/stop, adjustment of leaving water temperature setpoint, compressor operation lockout for kW demand limiting and control of ice making mode. The Tracer system reads monitoring information such as entering and leaving evaporator water temperatures and outdoor air temperature. Over 60 individual diagnostic codes can be read by the Tracer system. In addition, the Tracer system can provide sequencing control for up to 25 units on the same chilled water loop. Pump sequencing control can be provided from the Tracer system. Tracer ICS is not available in conjunction with the remote display or the external setpoint capability.

Controls

Required Options

1

Tracer Interface

Additional Options That May Be Used

Ice Making Control

External Trane Devices Required

Tracer Summit™, Tracer 100 System or Tracer Chiller Plant Control

Ice Making Systems Controls

An ice making option may be ordered with the air-cooled Series R™ chiller. The unit will have two operating modes, ice making and normal daytime cooling. In the ice making mode, the air-cooled Series R™ 70-125 ton chiller will operate at full compressor capacity until the return chilled fluid temperature entering the evaporator meets the ice making setpoint. This ice making setpoint is manually adjusted on the unit's

microcomputer. Two input signals are required to the air-cooled Series R™ 70-125 ton chiller for the ice making option. The first is an auto/stop signal for scheduling and the second is required to switch the unit in between the ice making mode and normal daytime operation. The signals are provided by a remote job site building automation device such as a time clock or a manual switch. In addition, the signals may be provided over the twisted wire pair from a Tracer™ system.

Required Options

External Auto/Stop (Standard)
Ice Making Control

Additional Options That May Be Used

Failure Indication Contacts
Communications Interface (For Tracer Systems)
Chilled Water Temperature Reset

External Trane Devices Required — None

Note: All wiring outside the unit is supplied at the job site.

Controls

Other Control Systems

Interface With Other Control Systems

Stand-alone Unit

Interface to stand-alone units is very simple; only a remote auto/stop for scheduling is required for unit operation. Signals from the chilled water pump contactor auxiliary or a flow switch are wired to the chilled waterflow interlock. Signals from a timeclock or some other remote device are wired to the external auto/stop input.

Note: Do not use the chilled water pump to stop the chiller.

Required Features

1. External Auto/Stop (Standard)
2. Chilled Waterflow Interlock (Standard)

Additional Features That May Be Used

1. Remote Running and Alarm Indication Contacts
2. External Interlock (Standard)
3. Chilled Water Temperature Reset

External Trane Devices Required —
None

Simple Interface With Other Control Systems

Microcomputer controls afford simple interface with other control systems, such as time clocks, building automation systems and ice storage systems. This means you have the flexibility to meet job requirements while not having to learn a complicated control system. This setup has the same standard features as a stand-alone water chiller, with the possibility of having the following optional features.

Alarm Indication Contacts

The unit provides three single-pole/double-throw contact closures to indicate that a failure has occurred, compressor on/off status, or if the compressors are running at maximum capacity. These contact closures may be used to trigger jobsite supplied alarm lights or alarm bells.

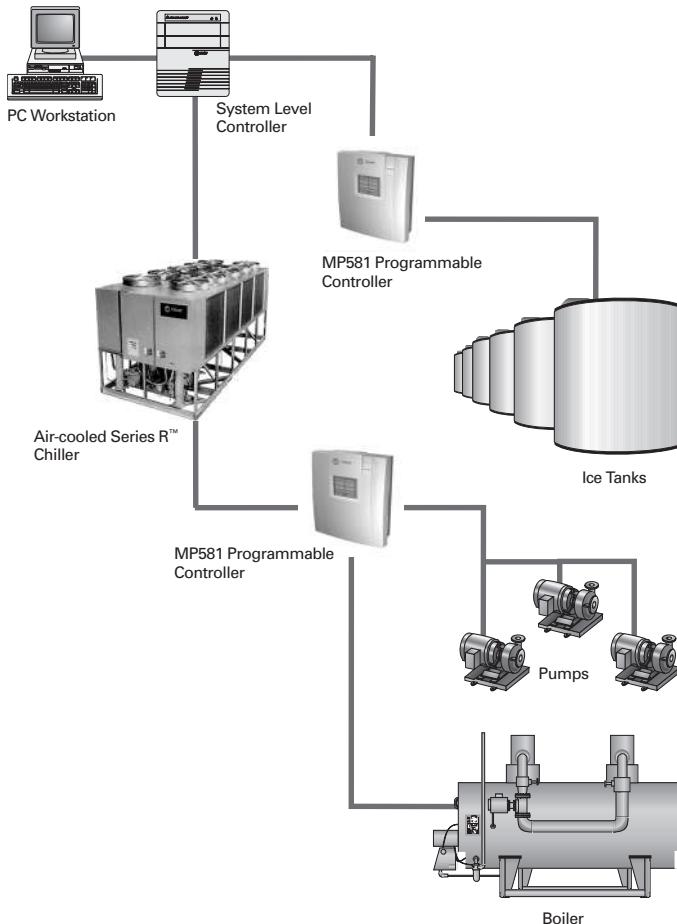

External Chilled Water Setpoint

Allows the external setting independent of the front panel setpoint by one of two means:

- a) 2-10 VDC input, or
- b) 4-20 mA input.

External Current Limit Setpoint

Allows the external setting independent of the front panel setpoint by one of two means:

- a) 2-10 VDC input, or
- b) 4-20 mA input.

Ice Making Control

Provides interface with ice making control systems.

Chilled Water Temperature Reset

Reset can be based on return water temperature or outdoor air temperature.

Controls

Ice Making Systems

An ice making option may be ordered with the air-cooled Series R™ chiller. The unit will have two operating modes, ice making and normal daytime cooling. In the ice making mode, the air-cooled Series R™ chiller will operate at full compressor capacity until the return chilled fluid temperature entering the evaporator meets the ice making set point. This ice making setpoint is manually adjusted on the unit's microcomputer. Two input signals are required to the air-cooled Series R™ chiller for the ice making option. The first is an auto/stop signal for scheduling and the second is required to switch the unit in between the ice making mode and normal daytime operation. The signals are provided by a remote jobsite building automation device such as a time clock or a manual switch. In addition, the signals may be provided over the twisted wire pair from a Tracer™ system.

Required Features

1. External Auto/Stop (Standard)
2. Ice Making Control

Additional Features That May Be Used

1. Remote Running and Failure Indication Contacts
2. Communications Interface (For Tracer Systems)
3. Chilled Water Temperature Reset (Indoor zone reset not available with ice making option).

External Trane Devices Required —

None

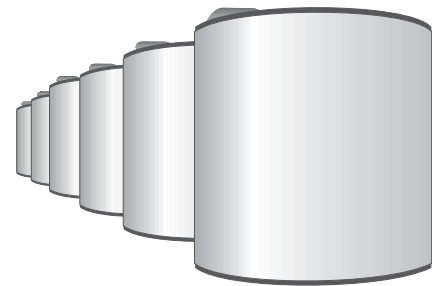

Ice Tanks

Controls

Remote Display

The remote display option allows the operator to monitor chiller operation from a remote location. Over 60 essential chiller operating parameters can be transmitted between the unit control module on the chiller and the remote display via a bi-directional communications link. Only one twisted wire pair is required between the chiller and the remote display. In addition to monitoring chiller operation, alarms and unit diagnostics can be read from the remote display. Furthermore, the chilled water temperature setpoint can be adjusted and the chiller can be turned on or off from the remote display.



Required Features

1. Communications Interface

Additional Features That May Be Used

1. External Interlock (Standard)
2. Chilled Water Temperature Reset
3. Chilled Waterflow Interlock (Standard)
4. Remote Running and Failure Indication Contacts

External Trane Devices Required

1. Remote Display Panel



Dimensional Data

Figure D-1 — RTAA 70-125 Unit Dimensions

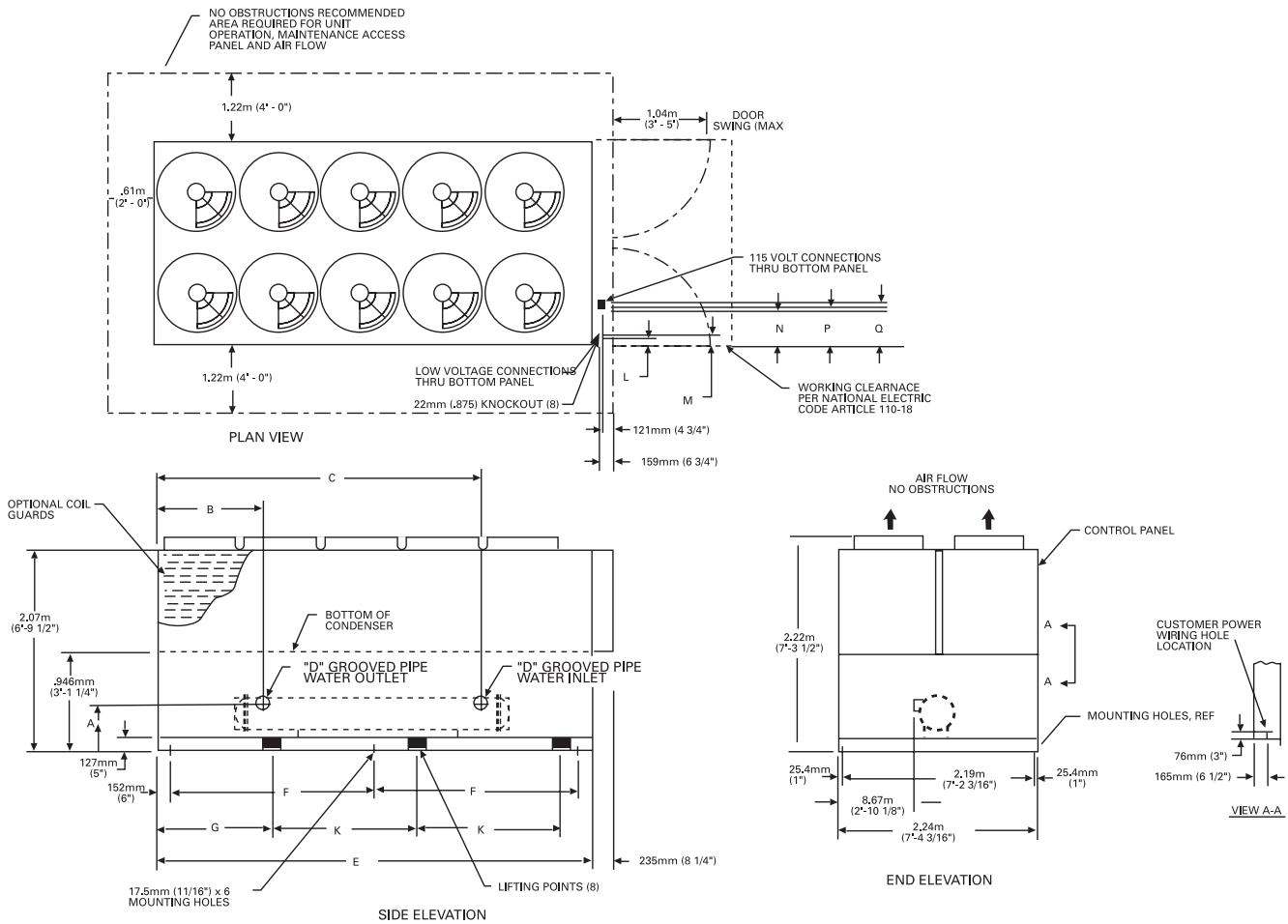

UNIT SIZE	A	B	C	D	E	F	G	K
70-100	.492m (1'-7 3/8")	1.213m (3'-11 3/4")	2.851m (9'-4 1/4")	102mm (4")	4.940m (16'-2 1/2")	2.317m (7'-7 1/4")	1.549m (5'-1")	1.626m (5'-4")
110-125	.479m (1'-6 7/8")	1.032m (3'-4 5/8")	3.499m (11'-5 3/4")	152mm (6")	5.626m (18'-5 1/2")	2.661m (8'-8 3/4")	1.511m (4'-11 1/2")	1.930m (6'-4")

UNIT SIZE	NO. OF FANS PER UNIT					
	70	80	90	100	110	125
NO. FANS						
STD UNIT	8	8	9	10	10	10

PANEL TYPE	115 VOLT & LOW VOLTAGE CONNECTIONS				
	L	M	N	P	Q
X-LINE					
CONTROL PANEL	.889m (2'-11")	.927m (3'-0 1/2")	1.206m (3'-11 1/2")	1.245m (4'-1")	1.283m (4'-2 1/2")
WYE DELTA					
CONTROL PANEL	76mm (3")	114mm (4 1/2")	.39m (1'-3 1/2")	.43m (1'-5")	.47m (1'-8 1/2")

Weights

Table W-1 — Packaged Unit Weights (Aluminum)

Unit Size	Units	Isolator Location						Operating Weight	Shipping Weight
		1	2	3	4	5	6		
RTAA 70	lbs.	1582	1608	1212	1232	842	856	7332	7000
	kg	718	729	550	559	382	388	3326	3175
RTAA 80	lbs.	1587	1613	1218	1237	848	862	7365	7049
	kg	720	732	552	561	385	391	3341	3197
RTAA 90	lbs.	1639	1596	1271	1237	903	879	7525	7234
	kg	743	724	577	561	410	399	3413	3281
RTAA 100	lbs.	1640	1668	1281	1303	922	937	7751	7483
	kg	744	757	581	591	418	425	3516	3394
RTAA 110	lbs.	1933	1885	1480	1443	1027	1001	8769	8326
	kg	877	855	671	655	466	454	3978	3777
RTAA 125	lbs.	1871	1902	1445	1469	1019	1036	8742	8360
	kg	849	863	655	666	462	470	3965	3792

Table W-2 — Packaged Unit Weights (Copper)

Unit Size	Units	Isolator Location						Operating Weight	Shipping Weight
		1	2	3	4	5	6		
RTAA 70	lbs.	1693	1719	1323	1343	953	966	7997	7665
	kg	768	780	600	609	432	438	3627	3477
RTAA 80	lbs.	1698	1724	1329	1348	959	972	8030	7714
	kg	770	782	603	611	435	441	3642	3499
RTAA 90	lbs.	1754	1711	1386	1352	1018	993	8214	7923
	kg	796	776	629	613	462	450	3726	3594
RTAA 100	lbs.	1759	1787	1400	1422	1041	1056	8465	8197
	kg	798	811	635	645	472	479	3840	3718
RTAA 110	lbs.	2065	2017	1612	1575	1159	1133	9561	9118
	kg	937	915	731	714	526	514	4337	4136
RTAA 125	lbs.	2016	2047	1590	1614	1164	1181	9612	9230
	kg	914	928	721	732	528	536	4360	4187

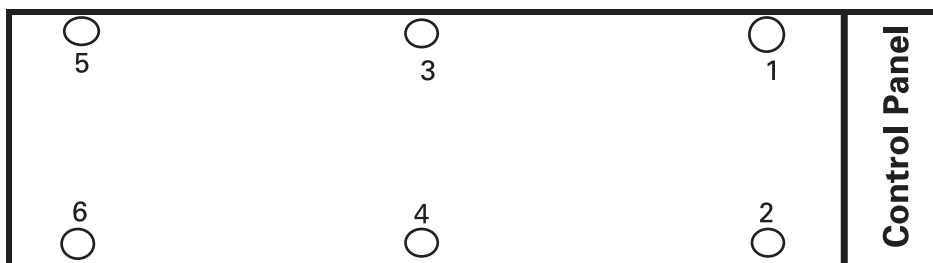

Options

Low Temperature Brine

The unit controls can be factory set to handle low temperature brine applications (0°F to 39°F).

Ice Making

The unit controls can be factory set to handle ice making for thermal storage applications.

Building Automation System Communication Interface

Permits either bi-directional communication to the Trane Integrated Comfort™ system or permits remote chilled water setpoint and demand limiting by accepting a 4-20 mA or 2-10 Vdc analog signal.

Remote Display

In addition to controlling chiller operation from remote location, the remote display shall provide the capability to monitor unit alarms and diagnostics. Only one twisted pair is required between the chiller and the remote display .

Remote Evaporator

The remote evaporator is available as a standard option.

This option provides an easily installed, pre-engineered method of installing the evaporator remotely indoors.

The remote evaporator is skid-mounted and is shipped separately from the outdoor (condensing) unit. Refrigerant accessories, including electronic expansion valve, moisture indicating sightglass and removable core filter drier, are shipped with the evaporator skid. All refrigerant connections are routed to one end of the evaporator skid for easy connection. All electrical wiring is factory installed and routed to a terminal box (entering and leaving water temperature sensor, evaporator refrigerant temperature sensor and electronic expansion valve control wiring). Suction refrigerant temperature sensors (two) must be field installed in the field suction line piping next to the evaporator connections.

Chilled Water Reset

This option provides the control logic and field installed sensors for either load based (return water temperature) or temperature based (ambient or zone) reset of leaving chilled water temperature (requires Communication Package).

Architectural Louvered Panels

Louvered panels cover the complete condensing coil and the service area beneath the coils.

Coil Protection

Louvered panels which protect the condenser coils only.

Access Protection

A coated wire mesh which covers access area underneath the condenser coils.

Control Power Transformer

This option eliminates the need to run separate 115 volt control power to the unit. A control power transformer is factory installed and wired. A separate 115 volt power source is required for 60 Hz heat tape.

Low Ambient Option

The low ambient option consists of a variable speed drive on the first fan of each circuit and special control logic to permit low temperature operation.

Low Ambient Lockout

A factory installed ambient sensor and control logic can prevent starting below the recommended temperature.

Non-Fused Power Disconnect Switch

A non-fused disconnect switch with a through the door handle is provided to disconnect main power.

Circuit Breaker

A standard interrupting molded case capacity circuit breaker (UL approved) is available. The circuit breaker can also be used to disconnect the chiller from main power with a through the door handle and comes pre-wired from the factory with terminal block power connections.

Neoprene Isolators

Isolators provide isolation between chiller and structure to help eliminate frequency transmission. Neoprene isolators are more effective and recommended over spring isolators.

Spring Isolators

Spring isolators help isolate the chiller from the building structure.

Condenser Corrosion Protection

Copper fins and CompleteCoat are available on all size units for corrosion protection. Job site conditions should be matched with the appropriate condenser fin materials to inhibit coil corrosion and ensure extended equipment life. The CompleteCoat option provides fully assembled coils with a flexible dip and bake epoxy coating.

Convenience Outlet

Provides a 15 amp, 115 volt (60 Hz) convenience outlet on the unit.

Typical Wiring Diagram

70-125 Tons

NOTES:

1. DASHED LINES INDICATE RECOMMENDED FIELD WIRING BY OTHERS. PHANTOM LINES INDICATE ALTERNATE CIRCUITRY OR AVAILABLE SALES OPTION. CHECK SALES ORDER TO DETERMINE IF WIRING IS REQUIRED FOR SPECIFIC OPTIONS.
2. ALL THREE PHASE MOTORS SUPPLIED WITH THE UNIT ARE PROTECTED UNDER PRIMARY SINGLE PHASE FAILURE CONDITIONS.
3. CAUTION - DO NOT ENERGIZE UNIT UNTIL CHECK OUT AND START-UP PROCEDURES HAVE BEEN COMPLETED.
- 4] SEE INSERT "A" FOR RESISTOR CONNECTIONS TO PROGRAM AN EXTERNAL CHILLED WATER SETPOINT WHEN 4 - 20 mA OR A 2 - 10 VDC SIGNAL IS NOT USED. SEE THE OPERATORS MANUAL FOR RESISTOR VALUES.
- 5] SEE INSERT "B" FOR RESISTOR CONNECTIONS TO PROGRAM AN EXTERNAL CURRENT LIMIT SETPOINT WHEN 4 - 20 mA OR A 2 - 10 VDC SIGNAL IS NOT USED. SEE THE OPERATORS MANUAL FOR RESISTOR VALUES.
- 6] SEE INSERT "C" FOR CONTACTS (IN PLACE OF THE ZONE TEMP. SENSOR) FOR OPTIONAL ICE MACHINE CONTROL - OPTION "A".
7. THE FOLLOWING CAPABILITIES ARE OPTIONAL - THEY ARE IMPLEMENTED AND WIRED AS REQUIRED FOR A SPECIFIC SYSTEM APPLICATION.
 - A] ICE-MACHINE CONTROL (CANNOT BE USED WITH OPT. L)
 - B] COMMUNICATIONS INTERFACE
 - D] WYE-DELTA CLOSED TRANSITION STARTER
 - E] CONTROL POWER TRANSFORMER.
 - H] UNIT DISCONNECT, NON-FUSED
 - J] CHILLED WATER RESET - RETURN WATER
 - K] CHILLED WATER RESET - OUTDOOR AIR
 - L] CHILLED WATER RESET - ZONE AIR (CANNOT BE USED WITH OPT. A)
 - Q] LOW AMBIENT LOCKOUT
 - S] CHILLED WATER FLOW SWITCH (NOT REQUIRED FOR CHILLER PROTECTION)
 - T] REMOTE CLEAR LANGUAGE DISPLAY

WIRING AND CONTACT REQUIREMENTS:

20. ALL FIELD WIRING MUST BE IN ACCORDANCE WITH THE NATIONAL ELECTRICAL CODE (NEC), STATE, AND LOCAL REQUIREMENTS. OUTSIDE THE UNITED STATES, OTHER COUNTRIES APPLICABLE NATIONAL AND/OR LOCAL REQUIREMENTS SHALL APPLY.
- 21] FOR UNITS WITHOUT THE CONTROL POWER TRANSFORMER (1T1) OPTION, THE CUSTOMER MUST PROVIDE CONTROL POWER OF 115 VAC, 60 HERTZ, SINGLE PHASE, 750 VA ON 130 THRU 215 TON UNITS. THE CONTROL POWER TRANSFORMER (1T1) IS STANDARD ON 50 HERTZ UNITS.
- 22] FOR ALL UNITS, THE HEAT TAPE MUST BE POWERED FROM A SEPARATE CUSTOMER PROVIDED 115 VAC, 420 WATT SOURCE FOR 200/230/420/575 60 HZ UNITS; 220 VAC, 420 WATT SOURCE FOR 346/1380/415 50 HZ UNITS. FOR THE OPTIONAL HEAT RECOVERY HEAT TAPE IS 420 WATTS.
- 23] CUSTOMER SUPPLIED CONTACTS MUST BE COMPATIBLE WITH DRY CIRCUIT 12 VDC, 45 mA RESISTIVE LOAD. SILVER OR GOLD PLATED CONTACTS ARE RECOMMENDED.
- 24] 30 VOLT OR LESS CIRCUIT. DO NOT RUN IN CONDUIT WITH HIGHER VOLTAGE CIRCUITS. USE #14-18 AWG. SEE SELECTION TABLE.
- 25] MINIMUM PILOT DUTY CONTACT RATING AT 115 VAC; 5.9 VA INRUSH, 1.3 VA SEALED.
- 26] FIELD WIRED ELECTRICAL LOADING IS NOT TO EXCEED THE FOLLOWING RATINGS:

TERMINALS	DEVICE	VOLTAGE	SEALED VA	INRUSH VA
1U1-TB4-1,2	1U1K1,NO	115	180	1150*
1U1-TB4-3	1U1K1,NC	115	180	1150*
1U1-TB4-5,4	1U1K2,NO	115	180	1150*
1U1-TB4-6,7	1U1K3,NC	115	180	1150*
1U1-TB4-8,9	1U1K2,NO	115	250	1150*
1U1-TB4-10,11	1U1K3,NC	115	180	1150*

*STANDARD PILOT DUTY RATING (35% POWER FACTOR).

- 27] WHEN CUSTOMER INPUT IS REQUIRED, REMOVE JUMPER AND INSTALL CUSTOMER WIRING.
- 28] CHILLED WATER PUMP CONTROL FROM TRANE UNIT UCM MODULE CHILLED WATER PUMP IS REQUIRED TO OPERATE A MINIMUM OF 1 MINUTE AFTER A COMMAND TO TERMINATE CHILLER OPERATION (UCM WILL PROVIDE THE DELAY CONTACTS). CHILLED WATER SYSTEM DEMAND SWITCH (S2) IS CONNECTED TO THE UCM EXTERNAL AUTO/STOP INPUT. NOTE: DO NOT USE THE CHILLED WATER PUMP TO STOP THE CHILLER.
- 29] AS SHIPPED 380/415 50 HZ VOLT UNIT TRANSFORMER 1T1-(OPTIONAL) IS WIRED FOR 415 VOLT OPERATION. IF UNIT IS TO BE OPERATED ON A 380 VOLT POWER SUPPLY, RE-CONNECT AS SHOWN IN INSET "D". REPROGRAM "UNIT LINE VOLTAGE" IN SERVICE SETTING MENU OF CLEAR LANGUAGE DISPLAY FROM 415 TO 380.
- 30] K1, K2, K3 RELAY OUTPUTS CAN BE PROGRAMMED TO PERFORM ALTERNATE FUNCTIONS. SEE INSTALLATION, OPERATION AND MAINTENANCE MANUAL FOR DETAILS. FUNCTION #1 IS SHOWN.

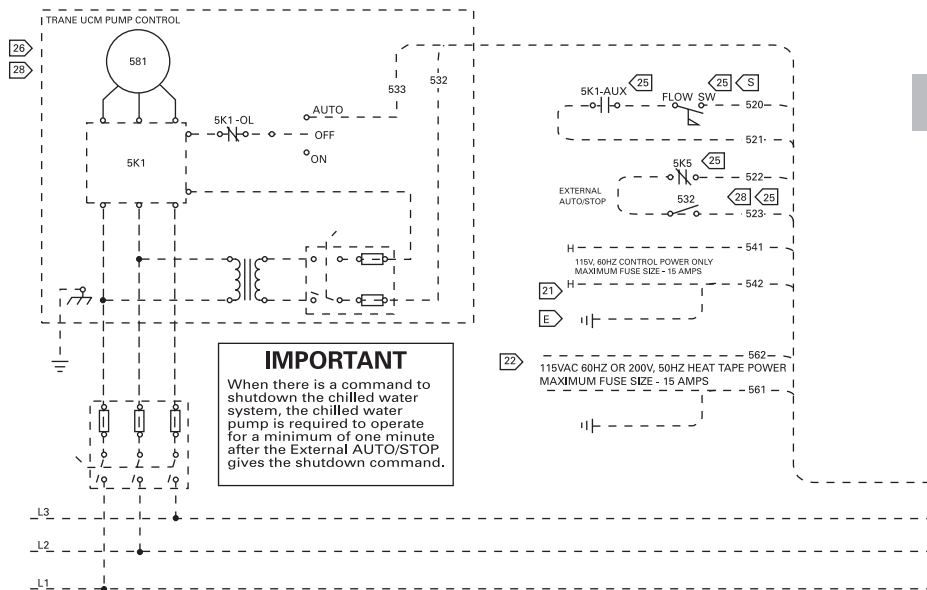

Typical Wiring Diagram

70-125 Tons

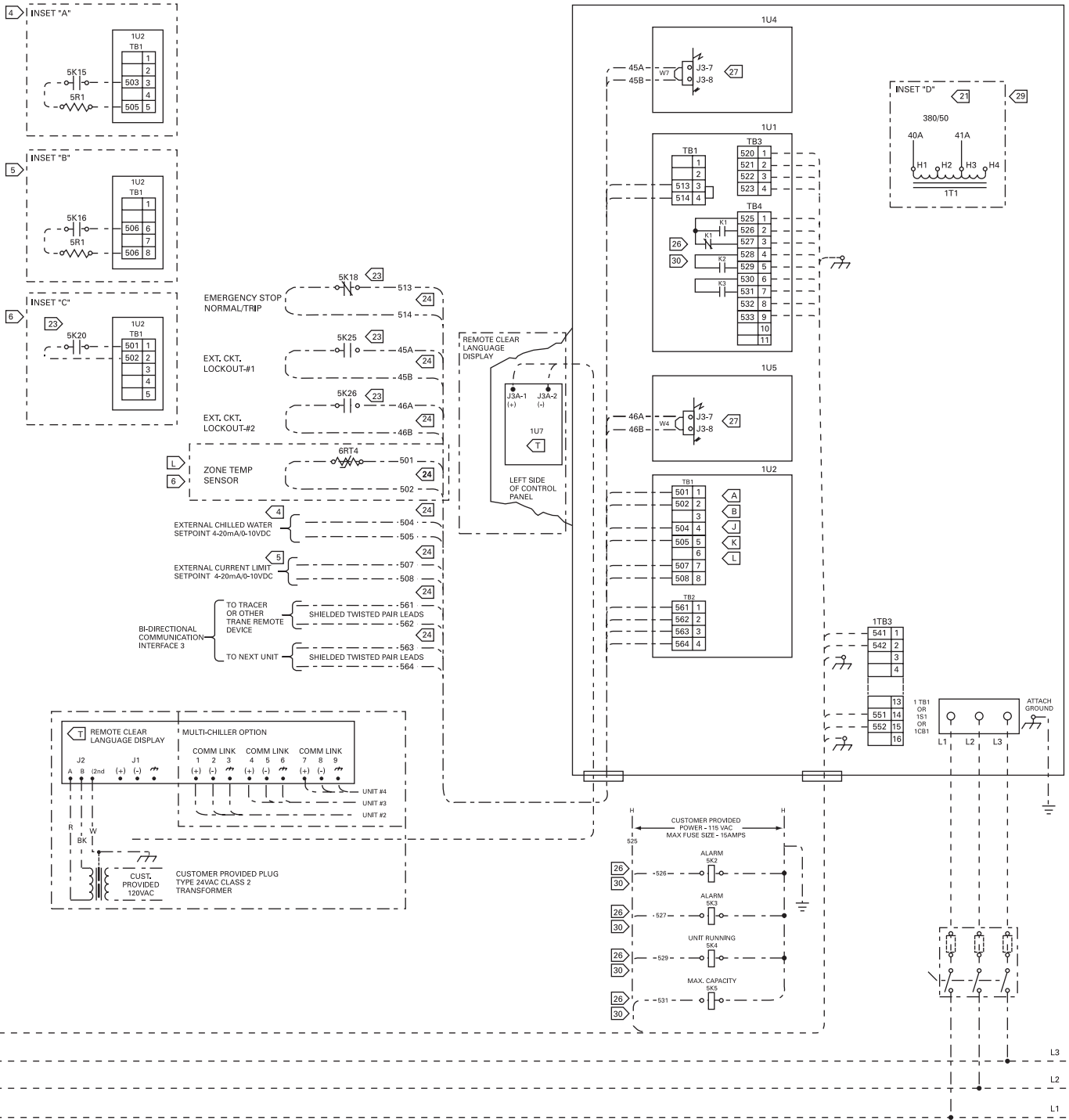

Features Summary

Trane RTAA Air-Cooled Series R™ Chiller Designed To Perform, Built To Last

Reliability

- Proven Trane helical rotary screw compressor design for longer life and greater dependability.
- Fewer moving parts means less parts to fail. Typical reciprocating compressors have 4 times as many total parts and 15 times as many critical parts.
- Adaptive Control™ protects the chiller when any of the system variables approaches a limit condition that may damage the unit or cause a shutdown. The Unit Control Module takes corrective action to keep the unit running.
- Dual circuit design increases overall system reliability.
- Unlike reciprocating designs, this compressor can handle liquid slugging.
- Suction gas cooling allows the motor to operate at lower temperatures for longer life.

Performance

- Superior full load efficiency. All units meet ASHRAE 90.1-2001 Standard.
- Excellent part load performance is achieved without resorting to manifolded multiple reciprocating compressors.
- Use of an electronic expansion valve significantly improves part load performance by minimizing superheat in the evaporator and allowing the chiller to run at reduced condensing temperatures.
- Unique compressor sequencing equalizes not only starts, but operating hours as well.

Trouble-Free Operation and Start-Up

- Adaptive Control™ microprocessor keeps the Series R™ chiller on-line when others would shut down.
- Fewer nuisance trips means less expense from unnecessary service calls.
- Factory installed and tested options keep start-up time and expenses minimized.
- Easy interface capability with the Trane Integrated Comfort™ system via a single twisted pair of wires.
- Optional remote display panel simplifies chiller monitoring/control.
- Packed stock availability for your ordering convenience.



Mechanical Specifications

General

Units are leak and pressure tested at 450 psig high side, 300 psig low side, then evacuated and charged. Packaged units ship with a full operating charge of oil and refrigerant. Unit panels, structural elements and control boxes are constructed of 12-gauge galvanized steel and mounted on a welded structural steel base. Unit panels and control boxes are finished with a baked on powder paint, and the structural base with an air dry paint. All paint meets the requirement for outdoor equipment of the U.S. Navy and other federal government agencies.

Evaporator

The evaporator is a tube-in-shell heat exchanger design with internally finned copper tubes roller expanded into the tube sheet. The evaporator is designed, tested and stamped in accordance with ASME for a refrigerant side working pressure of 300 psig. The evaporator is designed for a water side working pressure of 215 psig. Water connections are grooved pipe. The evaporator has one water pass with a series of internal baffles. Each shell includes a vent, a drain and fittings for temperature control sensors and is insulated with $\frac{3}{4}$ -inch Armaflex II or equal insulation ($K=0.26$). Heat tape with thermostat is provided to protect the evaporator from freezing at ambient temperatures down to -20°F .

Remote Evaporator

The evaporator is a tube-in-shell heat exchanger, designed with internally-finned copper tubes that are rolled expanded into the tube sheet. The evaporator is designed, tested and stamped for a refrigerant side working pressure of 300 psig, in accordance with ASME. The evaporator is designed for a water side working pressure of 215 psig. Water connections are victaulic. The evaporator has one water pass, with a series of internal baffles.

Each shell includes a vent and drain connection, as well as factory-mounted entering and leaving water temperature control sensors and evaporator refrigerant temperature sensors. The evaporator is insulated with $\frac{3}{4}$ -inch Armaflex II or equal insulation ($K=0.26$).

The evaporator is skid-mounted and is shipped separately from the outdoor (condensing) unit. Refrigerant accessories, including electronic expansion valve, moisture indicating sightglass and removable core filter drier, are shipped with the evaporator skid. All refrigerant connections are routed to one end of evaporator skid for easy connection. All electrical wiring is factory installed and routed to a terminal box (entering and leaving water temperature sensor, evaporator refrigerant temperature sensor and electronic expansion valve control wiring). Suction refrigerant temperature sensors (two) must be field installed in the field suction line piping next to the evaporator connections.

Condenser and Fans

Air-cooled condenser coils have aluminum fins mechanically bonded to internally finned seamless copper tubing. The condenser coil has an integral subcooling circuit and also provides oil cooling for the compressor bearing and injection oil. Condensers are factory proof and leak tested at 506 psig.

Direct-drive vertical discharge condenser fans are dynamically balanced. Three-phase condenser fan motors with permanently lubricated ball bearing and internal thermal overload protection are provided. Standard units will start and operate down to 25°F ambient.

Compressor and Lube Oil System

The rotary screw compressor is semi-hermetic, direct drive, 3600 rpm, with capacity control slide valve, rolling element bearings, differential refrigerant pressure oil pump and oil heater. The motor is a suction gas cooled, hermetically sealed, two-pole squirrel cage induction motor.

Oil separator and filtration devices are provided separate from the compressor. Check valves in the compressor discharge and lube oil system and a solenoid valve in the lube system are provided.

Mechanical Specifications

Refrigeration Circuits

Each unit has two refrigerant circuits, with one rotary screw compressor per circuit. Each refrigerant circuit includes a compressor suction and discharge service valve, liquid line shutoff valve, removable core filter drier, liquid line sight glass with moisture indicator, charging port and an electronic expansion valve. Fully modulating compressors and electronic expansion valves provide variable capacity modulation over the entire operating range.

Unit Controls

All unit controls are housed in a weathertight enclosure with removable plates to allow for customer connection of power wiring and remote interlocks. All controls, including sensors, are factory mounted and tested prior to shipment. All cataloged units are UL listed.

Microcomputer controls provide all control functions including start-up and shut down, leaving chilled water temperature control, compressor and electronic expansion valve modulation, fan sequencing, antirecycle logic, automatic lead/lag compressor starting and load limiting.

The unit control module, utilizing Adaptive Control™ microprocessor, automatically takes action to avoid unit shutdown due to abnormal operating conditions associated with low refrigerant temperature, high condensing temperature and motor current overload. Should the abnormal operating condition continue until a protective limit is violated, the unit will be shut down.

Unit protective functions include loss of chilled water flow, evaporator freezing, loss of refrigerant, low refrigerant pressure, high refrigerant pressure, reverse rotation, compressor starting and running over current, phase loss, phase imbalance, phase reversal, and loss of oil flow.

A menu driven digital display indicates over 20 operating data points including chilled water setpoint, current limit setpoint, leaving chilled water temperature, evaporator and condenser refrigerant pressures and temperatures. Over 60 diagnostic checks are made and displayed when a problem is detected. The digital display can be read and advanced on the unit without opening any control panel doors.

Standard power connections include main three phase power and two 115 volt single phase power connections for control power and heat tape.

Starters

Starters are housed in a weathertight enclosure with removable cover plate to allow for customer connection of power wiring. Across-the-line starters are standard on all 460-575 volt units. An optional Wye Delta closed transition starter (33 percent of LRA inrush) is available. Typically, Trane helical rotary compressors are up to full speed in one second when started across-the-line and have equivalent inrush with similar size reciprocating compressor with part wind starters.



Standard Conversion Table

To Convert From:	To:	Multiply By:	To Convert From:	To:	Multiply By:
Length					
Feet (ft)	meters (m)	.30481	British Thermal Units (BTU)	Kilowatt (kW)	.000293
Inches (In)	millimeters (mm)	25.4	British Thermal Units (BTU)	KCalorie (Kcal)	.252
Area					
Square Feet (ft ²)	square meters (m ²)	.093	Tons (refrig. effect)	Kilowatt (refrig. effect)	3.516
Square Inches (In ²)	square millimeters (mm ²)	645.2	Tons (refrig. effect)	Kilocalories per hour (Kcal/hr)	3024
Volume					
Cubic Feet (ft ³)	Cubic meters (m ³)	.0283	Horsepower	Kilowatt (kW)	.7457
Cubic Inches (In ³)	Cubic mm (mm ³)	16387	Pressure		
Gallons (gal)	litres (l)	3.785	Feet of water (ftH ₂ O)	Pascals (PA)	2990
Gallons (gal)	cubic meters (m ³)	.003785	Inches of water (inH ₂ O)	Pascals (PA)	249
Flow					
Cubic feet/min (cfm)	cubic meters/second (m ³ /s)	.000472	Pounds per square inch (PSI)	Pascals (PA)	6895
Cubic feet/min (cfm)	cubic meters/hr (m ³ /hr)	1.69884	PSI	Bar or KG/CM ²	6.895 × 10 ⁻²
Gallons/minute (GPM)	cubic meters/hr (m ³ /hr)	.2271	Weight		
Gallons/minute (GPM)	litres/second (l/s)	.06308	Ounces (oz)	Kilograms (kg)	.02835
Velocity					
Feet per minute (ft/m)	meters per second (m/s)	.00508	Pounds (lbs)	Kilograms (kg)	.4536
Feet per second (ft/s)	meters per second (m/s)	.3048	Fouling factors for heat exchangers		
.00010 ft ² °F hr/BTU = .0176 m ² ° K/kW					
.00025 ft ² °F hr/BTU = .044 m ² ° K/kW					

Temperature — Centigrade (°C) Versus Fahrenheit (°F)

Note: The center columns of numbers, referred to as BASE TEMP., is the temperature in either degrees Fahrenheit (°F) or Centigrade (°C), whichever is desired to convert into the other. If degrees Centigrade is given, read degrees Fahrenheit to the right. If degrees Fahrenheit is given, read degrees Centigrade to the left.

Temperature			Temperature			Temperature			Temperature			Temperature		
°C	C or F	°F	°C	C or F	°F	°C	C or F	°F	°C	C or F	°F	°C	C or F	°F
-40.0	-40	-40.0	-15.0	+5	+41.0	+10.0	+50	+122.0	+35.0	+95	+203.0	+60.0	+140	+284.0
-39.4	-39	-38.2	-14.4	+6	+42.8	+10.6	+51	+123.8	+35.6	+96	+204.8	+60.6	+141	+285.8
-38.9	-38	-36.4	-13.9	+7	+44.6	+11.1	+52	+125.6	+36.1	+97	+206.6	+61.1	+142	+287.6
-38.3	-37	-34.6	13.3	+8	+46.4	+11.7	+53	+127.4	+36.7	+98	+208.4	+61.7	+143	+289.4
-37.8	-36	-32.8	-12.8	+9	+48.2	+12.2	+54	+129.2	+37.2	+99	+210.2	+62.2	+144	+291.2
-37.2	-35	-31.0	-12.2	+10	+50.0	+12.8	+55	+131.0	+37.8	+100	+212.0	+62.8	+145	+293.0
-36.7	-34	-29.2	-11.7	+11	+51.8	+13.3	+56	+132.8	+38.3	+101	+213.8	+63.3	+146	+294.8
-36.1	-33	-27.4	-11.1	+12	+53.6	+13.9	+57	+134.6	+38.9	+102	+215.6	+63.9	+147	+296.6
-35.6	-32	-25.6	-10.6	+13	+55.4	+14.4	+58	+136.4	+39.4	+103	+217.4	+64.4	+148	+298.4
-35.0	-31	-23.8	-10.0	+14	+57.2	+15.0	+59	+138.2	+40.0	+104	+219.2	+65.0	+149	+300.2
-34.4	-30	-22.0	-9.4	+15	+59.0	+15.6	+60	+140.0	+40.6	+105	+221.0	+65.6	+150	+302.0
-33.9	-29	-20.2	-8.9	+16	+60.8	+16.1	+61	+141.8	+41.1	+106	+222.8	+66.1	+151	+303.8
-33.3	-28	-18.4	-8.3	+17	+62.6	+16.7	+62	+143.6	+41.7	+107	+224.6	+66.7	+152	+305.6
-32.8	-27	-16.6	-7.8	+18	+64.4	+17.2	+63	+145.4	+42.2	+108	+226.4	+67.2	+153	+307.4
-32.2	-26	-14.8	-7.2	+19	+66.2	+17.8	+64	+147.2	+42.8	+109	+228.2	+67.8	+154	+309.2
31.7	-25	-13.0	-6.7	+20	+68.0	+18.3	+65	+149.0	+43.3	+110	+230.0	+68.3	+155	+311.0
-31.1	-24	-11.2	-6.1	+21	+69.8	+18.9	+66	+150.8	+43.9	+111	+231.8	+68.9	+156	+312.8
-30.6	-23	-9.4	-5.5	+22	+71.6	+19.4	+67	+152.6	+44.4	+112	+233.6	+69.4	+157	+314.6
-30.0	-22	-7.6	-5.0	+23	+73.4	+20.0	+68	+154.4	+45.0	+113	+235.4	+70.0	+158	+316.4
-29.4	-21	-5.8	-4.4	+24	+75.2	+20.6	+69	+156.2	+45.6	+114	+237.2	+70.6	+159	+318.2
-28.9	-20	-4.0	-3.9	+25	+77.0	+21.1	+70	+158.0	+46.1	+115	+239.0	+71.1	+160	+320.0
-28.3	-19	-2.2	-3.3	+26	+78.8	+21.7	+71	+159.8	+46.7	+116	+240.8	+71.7	+161	+321.8
-27.8	-18	-0.4	-2.8	+27	+80.6	+22.2	+72	+161.6	+47.2	+117	+242.6	+72.2	+162	+323.6
27.2	-17	+1.4	-2.2	+28	+82.4	+22.8	+73	+163.4	+47.8	+118	+244.4	+72.8	+163	+325.4
26.7	-16	+3.2	-1.7	+29	+84.2	+23.3	+74	+165.2	+48.3	+119	+246.2	+73.3	+164	+327.2
-26.1	-15	+5.0	-1.1	+30	+86.0	+23.9	+75	+167.0	+48.9	+120	+248.0	+73.9	+165	+329.0
-25.6	-14	+6.8	-0.6	+31	+87.8	+24.4	+76	+168.8	+49.4	+121	+249.8	+74.4	+166	+330.8
-25.0	-13	+8.6	0	+32	+89.6	+25.0	+77	+170.6	+50.0	+122	+251.6	+75.0	+167	+332.6
-24.4	-12	+10.4	+0.6	+33	+91.4	+25.6	+78	+172.4	+50.6	+123	+253.4	+75.6	+168	+334.4
23.9	-11	+12.2	+1.1	+34	+93.2	+26.1	+79	+174.2	+51.1	+124	+255.2	+76.1	+169	+336.2
-23.3	-10	+14.0	+1.7	+35	+95.0	+26.7	+80	+176.0	+51.7	+125	+257.0	+76.7	+170	+338.0
-22.8	-9	+15.8	+2.2	+36	+96.8	+27.2	+81	+177.8	+52.2	+126	+258.8	+77.2	+171	+339.8
-22.2	-8	+17.6	+2.8	+37	+98.6	+27.8	+82	+179.6	+52.8	+127	+260.6	+77.8	+172	+341.6
-21.7	-7	+19.4	+3.3	+38	+100.4	+28.3	+83	+181.4	+53.3	+128	+262.4	+78.3	+173	+343.4
-21.1	-6	+21.2	+3.9	+39	+102.2	+28.9	+84	+183.2	+53.9	+129	+264.2	+78.9	+174	+345.2
20.6	-5	+23.0	+4.4	+40	+104.0	+29.4	+85	+185.0	+54.4	+130	+266.0	+79.4	+175	+347.0
-20.0	-4	+24.8	+5.0	+41	+105.8	+30.0	+86	+186.8	+55.0	+131	+267.8	+80.0	+176	+348.8
-19.4	-3	+26.6	+5.5	+42	+107.6	+30.6	+87	+188.6	+55.6	+132	+269.6	+80.6	+177	+350.6
18.9	-2	+28.4	+6.1	+43	+109.4	+31.1	+88	+190.4	+56.1	+133	+271.4	+81.1	+178	+352.4
-18.3	-1	+30.2	+6.7	+44	+111.2	+31.7	+89	+192.2	+56.7	+134	+273.2	+81.7	+179	+354.2
-17.8	0	+32.0	+7.2	+45	+113.0	+32.2	+90	+194.0	+57.2	+135	+275.0	+82.2	+180	+356.0
-17.2	+1	+33.8	+7.8	+46	+114.8	+32.8	+91	+195.8	+57.8	+136	+276.8	+82.8	+181	+357.8
-16.7	+2	+35.6	+8.3	+47	+116.6	+33.3	+92	+197.6	+58.3	+137	+278.6	+83.3	+182	+359.6
-16.1	+3	+37.4	+8.9	+48	+118.4	+33.9	+93	+199.4	+58.9	+138	+280.4	+83.9	+183	+361.4
-15.6	+4	+39.2	+9.4	+49	+120.2	+34.4	+94	+201.2	+59.4	+139	+282.2	+84.4	+184	+363.2

FOR INTERPOLATION IN THE ABOVE TABLE USE:

BASE TEMPERATURE (°F or °C):

DEGREES CENTIGRADE:

DEGREES FAHRENHEIT:

1	2	3	4	5	6	7	8	9	10
0.56	1.11	1.67	2.22	2.78	3.33	3.89	4.44	5.00	5.56
1.8	3.6	5.4	7.2	9.0	10.8	12.6	14.4	16.2	18.0



Trane
A business of American Standard Companies
www.trane.com

For more information contact your local district office or e-mail us at comfort@trane.com

Literature Order Number	RLC-PRC016-EN
File Number	PL-RF-RLC-PRC016-EN-08 02
Supersedes	RLC-DS-2
Stocking Location	Inland-La Crosse

Trane has a policy of continuous product and product data improvement and reserves the right to change design and specifications without notice.