

Product information presented here reflects conditions at time of publication. Consult factory regarding discrepancies or inconsistencies.



95 North Oak Street
Kendallville, IN 46755
800-742-5044

visit our web site:
starwatersystems.com

INSTALLATION INSTRUCTIONS

MODEL COND-1 Condensate Pump

PREINSTALLATION CHECKLIST - ALL INSTALLATIONS

1. Inspect all materials. Occasionally, products are damaged during shipment. If the unit is damaged, contact your dealer before using.
2. Carefully read all the literature provided to familiarize yourself with specific details regarding installation and use before attempting the installation. These materials should be retained for future reference.

	⚠ WARNING	SEE BELOW FOR LIST OF WARNINGS
---	------------------	---------------------------------------

1. **To help reduce the risk of electrical shock**, a properly grounded receptacle or control box of grounding type must be installed and protected by a ground fault circuit interrupter (GFCI) in accordance with the National Electrical Code and applicable local codes. If pump is wired direct, a GFCI must be installed in the control box. **(SEE WARNING BELOW)**
2. Make certain that the ground fault interrupter protected receptacle or control box is within reach of the pump's power supply cord. **DO NOT USE AN EXTENSION CORD.** Extension cords that are too long or too light do not deliver sufficient voltage to the pump motor. But more important, they could present a safety hazard if the insulation were to become damaged or the connection end were to fall into a damp or wet area.
3. **Make sure the pump's electrical supply circuit is equipped with fuses or circuit breakers of proper**

4. **TESTING FOR GROUND.** As a safety measure, each electrical outlet should be checked for ground using an Underwriters Laboratory Listed circuit analyzer which will indicate if the power, neutral and ground wires are correctly connected to your outlet. If they are not, call a qualified licensed electrician.
5. Installation and checking of electrical circuits and hardware should only be performed by a qualified licensed electrician.
6. **FOR YOUR PROTECTION ALWAYS DISCONNECT PUMP FROM ITS POWER SOURCE BEFORE HANDLING.**
7. According to the state of California (Prop 65), this product contains chemicals known to the state of California to cause cancer and birth defects or other reproductive harm.

⚠ CAUTION		SEE BELOW FOR LIST OF CAUTIONS
------------------	--	---------------------------------------

1. Check to be sure your power source is adequate to handle the amperage requirements of the motor as indicated on the pump or unit I.D. tag.
2. All plumbing (discharge and drain lines) must be installed to meet local codes.

NOTE: Pumps with the "UL" mark and pumps with the "US" mark are tested to UL Standard UL778. CSA Certified pumps are certified to CSA Standard C22.2 No. 108.

REFER TO WARRANTY ON PAGE 2.

Limited Warranty

This product is warranted for one year from the date of purchase or two years from the date of manufacture, whichever occurs first. Subject to the conditions hereinafter set forth, the manufacturer will repair or replace to the original consumer, any portion of the product which proves defective due to defective materials or workmanship. To obtain warranty service, contact the dealer from whom the product was purchased. The manufacturer retains the sole right and option to determine whether to repair or replace defective equipment, parts or components. Damage due to conditions beyond the control of the manufacturer is not covered by this warranty.

THIS WARRANTY WILL NOT APPLY: (a) To defects or malfunctions resulting from failure to properly install, operate or maintain the unit in accordance with printed instructions provided; (b) to failures resulting from abuse, accident or negligence or use of inappropriate chemicals or additives in the water; (c) to normal maintenance services and the parts used in connection with such service; (d) to units which are not installed in accordance with normal applicable local codes, ordinances and good trade practices; and (e) the unit is used for purposes other than for what it was designed and manufactured.

RETURN OF WARRANTED COMPONENTS: Any item to be repaired or replaced under this warranty must be returned to the manufacturer at Kendallville, Indiana or such other place as the manufacturer may designate, freight prepaid.

THE WARRANTY PROVIDED HEREIN IS IN LIEU OF ALL OTHER EXPRESS WARRANTIES, AND MAY NOT BE EXTENDED OR MODIFIED BY ANYONE. ANY IMPLIED WARRANTIES SHALL BE LIMITED TO THE PERIOD OF THE LIMITED WARRANTY AND THEREAFTER ALL SUCH IMPLIED WARRANTIES ARE DISCLAIMED AND EXCLUDED. THE MANUFACTURER SHALL NOT, UNDER ANY CIRCUMSTANCES, BE LIABLE FOR INCIDENTAL, CONSEQUENTIAL OR SPECIAL DAMAGES, SUCH AS, BUT NOT LIMITED TO DAMAGE TO, OR LOSS OF, OTHER PROPERTY OR EQUIPMENT, LOSS OF PROFITS, INCONVENIENCE, OR OTHER INCIDENTAL OR CONSEQUENTIAL DAMAGES OF ANY TYPE OR NATURE. THE LIABILITY OF THE MANUFACTURER SHALL NOT EXCEED THE PRICE OF THE PRODUCT UPON WHICH SUCH LIABILITY IS BASED.

This warranty gives you specific legal rights, and you may have other rights which vary from state to state. Some states do not allow limitations on duration of implied warranties or exclusion of incidental or consequential damages, so the above limitations may not apply to you.

In those instances where damages are incurred as a result of an alleged pump failure, the Homeowner must retain possession of the pump for investigation purposes.

Servicing of a Double-Insulated Appliance

In a double-insulated product, two systems of insulation are provided instead of grounding. No grounding means is provided on a double-insulated product, nor should a means for grounding be added to the product. Servicing a double-insulated product requires extreme care and knowledge of the system, and should be done only by qualified service personnel. A double-insulated product is marked with the words "DOUBLE-INSULATION" or "DOUBLE-INSULATED".

Maintenance Guidelines

Cleaning of Reservoir and Impeller:

- 1) Remove entire pump from wall, if mounted.
- 2) Disassemble reservoir from the deck by removing the four screws located at the corners of the deck.
- 3) Remove the impeller cover by loosening the five screws on the underside of the motor. Remove the impeller shaft assembly.
- 4) Wipe off the gasket between the impeller & the motor housing with a damp cloth.
- 5) Reassemble impeller to the motor, then reassemble reservoir to the deck.

Cleaning of Check Valve:

- 1) Remove discharge line from valve.
- 2) Remove check valve with 9/16" wrench.
- 3) Visually check for obstructions or damage.
- 4) Replace valve by hand tightening, then tighten 1/2 turn with a 9/16" wrench.

CAUTION Do not overtighten, damage to the O-ring seal may occur.

Ten Helpful Hints For Easy Installation

1. **Read** all instructions before beginning installation.
2. Be sure the installation does not exceed a maximum of 15 feet of vertical lift.
3. Be sure the pump is level within 1/8" for the length of the condensate pump.
4. Use soapy water when cleaning unit. Refer to maintenance guidelines.
5. For best results, drain and discharge lines should have a continuous downward slope.
6. Test operation of pump per STEP 5.
7. Do not overtighten check valve after cleaning. Refer to maintenance guidelines.
8. Plug pump into a constant voltage source. Do not plug into a device that runs intermittently.
9. The model number and date code can be found on the cord warning label.
10. For best results, the highest point of the discharge line should be higher than 5' above floor.

Do's And Don't's For Installing A Unit

1. **DO read all installation material included with the pump.**
2. **DO** inspect unit for any visible damage caused by shipping. Contact dealer if unit appears to be damaged.
3. **DO** clean all debris from the pump reservoir.
4. **DO** always disconnect pump from power source before handling. **DO** always connect to a separately protected and properly grounded ground fault protected circuit. **DO NOT** ever cut, splice or damage power cord. **DO NOT** carry or lift pump by its power cord. **DO NOT** use an extension cord with this condensate pump.
5. **DO NOT** use a discharge pipe smaller than the pump discharge size.
6. **DO** test pump immediately after installation to be sure that the system is working properly.
7. **DO** review all applicable local and national codes and verify that the installation conforms to each of them.

Performance Characteristics

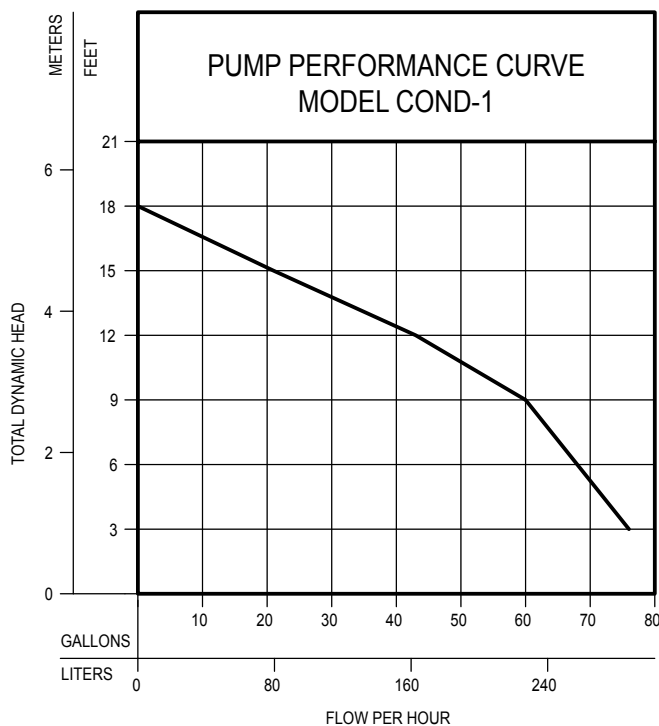

TOTAL DYNAMIC HEAD/FLOW PER HOUR CONDENSATE

MODEL		COND-1	
Feet	Meters	Gal.	Liters
3	.9	76	288
6	1.8	68	257
9	2.7	60	227
12	3.7	43	163
15	4.6	21	79
Shut-off head:		18 ft. (5.5m)	

IL0540

STEP 1

Mounting Location

- 1.1) Select a location for the pump that is below the evaporator drain and/or furnace drain.
- 1.2) The unit has two brackets built into the deck so that it can be installed to the wall or side of the appliance. Refer to Figure 1.2.

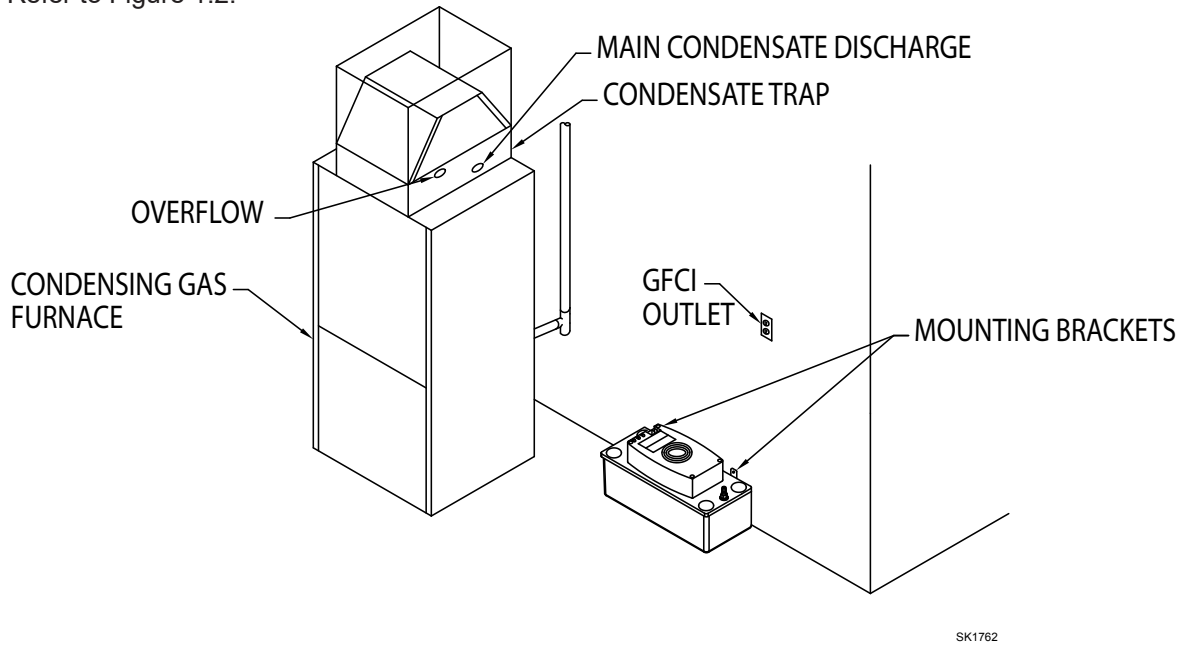

Figure 1.2

SK1762

STEP 2

Installation of Condensate Drain Lines

- 2.1) To prevent pipe blockage, modify the end of the pipe or tubing as shown in Figure 2.1.
- 2.2) Plumb, flexible tube or pipe, from the condensate drain and/or from the furnace drain to the inlet hole(s) on the pump. Refer to Figure 2.2.

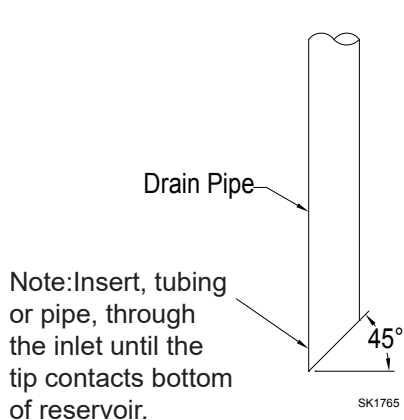

Figure 2.1

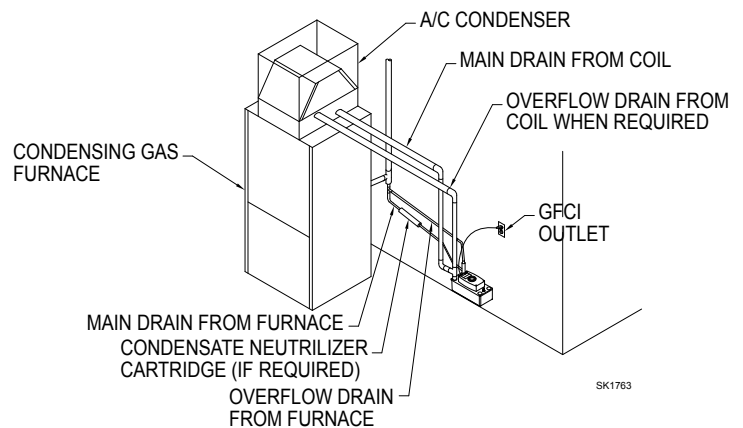

Figure 2.2

Note: The drain line(s) should have a continuous downward slope to allow for gravity flow.

Note: Local codes may require the use of a condensate neutralizer when using this pump.

Note: Make sure the drain lines from the A.C. condenser are supported above the reservoir and no weight from the drain line is directed to the bottom of the reservoir.

STEP 3

Installation of Discharge Line

Note: Do not use flexible tubing larger than 3/8" ID. A hose clamp (not included) is recommended.

- 3.1) Extend the discharge pipe, from the barbed check valve, to the highest point possible. Refer to Figure 3.1
- 3.2) From this point, direct the discharge line to the location of the main drain, maintain a continuous downward slope.

Note: If a continuous downward slope is not possible, then make an inverted "U" at the highest point of the discharge line.

Note: Make sure the 3/8" ID tube is supported in a way it will not "Kink or Pinch off" blocking flow.

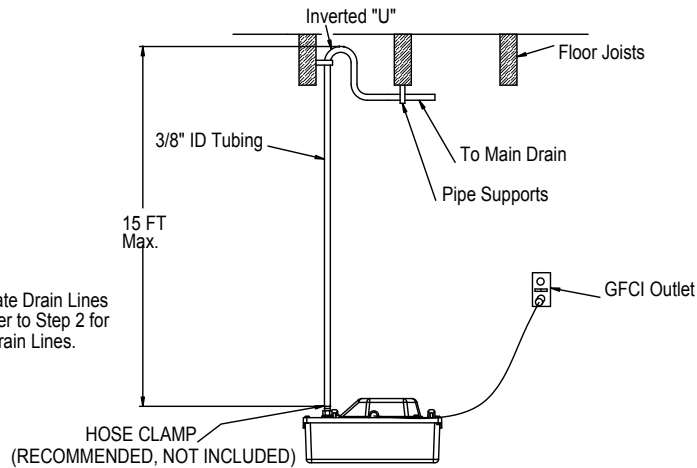

Figure 3.1

SK1764

STEP 4

Installation of Safety Switch

NOTE: If the unit does not have the Safety Switch feature, then skip to STEP 5.

CAUTION

Connect power cord to a constant voltage source, not a fan or other device which may run intermittently.

- 4.1) The unit can be wired directly to the appliance thermostat to shut the pump and the appliance down in the event pump fails. Refer to Figure 4.1 for access to the Safety Switch. Refer to Figure 4.2 for typical wiring diagram.

NOTE: The alarm can be wired into the Safety Switch at the normally open (NO) contact.

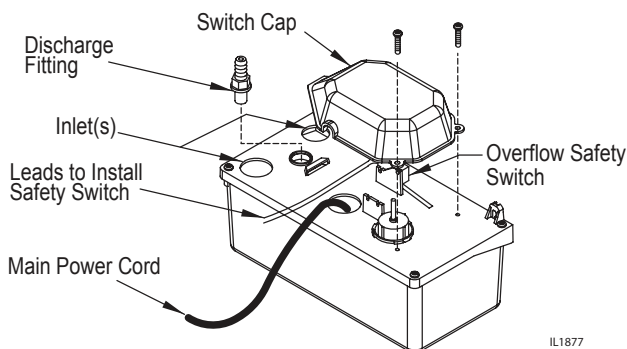

Figure 4.1

IL1877

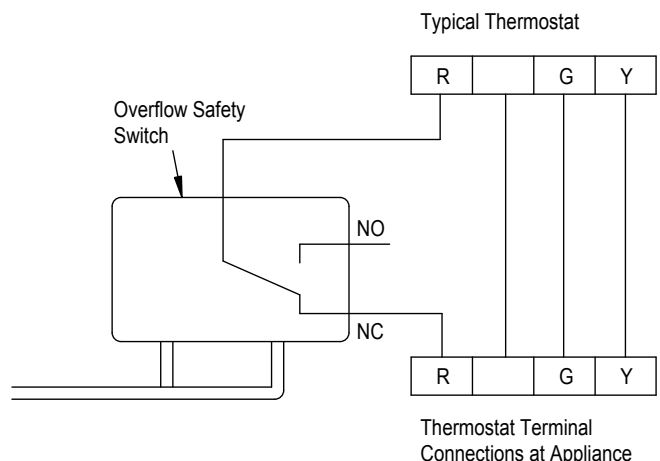

Figure 4.1

Thermostat Terminal Connections at Appliance

STEP 5**Testing of Pump Operation****5.1) Testing of Pump (Main Switch)**

- 1) With the discharge line in place, plug in the pump.
- 2) Pour water into the pump reservoir, through one of the inlets, until the pump activates to verify that the unit works.

Note: If both inlets are plumbed, then it will be necessary to temporarily remove one of the pipes in order to pour water into the reservoir. Replace pipe once testing is complete.

5.2) Testing of Safety Switch (If applicable)

Note: Unplug the pump for this test.

- 1) Energize the appliance so that it runs.
- 2) Pour water into the reservoir as described in Section 5.1 item 2.
- 3) As water rises in the reservoir, the overflow Switch should activate, breaking the thermostat circuit to the appliance and/or triggering the alarm.
- 4) Plug the pump in and allow the pump to empty the tank. As the water level decreases, the appliance will reset.

Trouble Shooting Guide

Condition	Possible Cause	Remedy
A. UNIT DOESN'T RUN.	Pump not plugged in.	Plug in.
	Low voltage; blown fuse, open circuit.	Have a qualified electrician check fuse circuit.
	No condensate in reservoir.	Be certain the appliance is generating condensate. Check drain line(s) and/or discharge line for blockage.
	Motor or wiring shorted.	Contact Factory.
	Drain/Discharge line(s) blocked.	Check drain line(s) and/or discharge line for blockage.
B. PUMP MAKES LOUD NOISES WHEN RUNNING.	Debris in reservoir.	Refer to "Maintenance Guidelines" section for cleaning instructions.
C. PUMP RUNS BUT DOES NOT PUMP LIQUID OUT.	Float bound.	Refer to "Maintenance" section for cleaning instructions.
	Maximum discharge height exceeded.	Measure from bottom of pump to highest point. Rework discharge if height is greater than 18'. Refer to STEP 3 for guidelines.
	Discharge tube blocked.	Check discharge line for blockage, remove debris.
	Check Valve obstruction.	Refer to "Maintenance" section for cleaning instructions.
	Check Valve damaged.	Contact Factory.
D. LIQUID DRAINS BACK INTO PUMP FROM DISCHARGE LINE.	Check Valve damaged.	Contact Factory.
	Check Valve obstruction.	Refer to "Maintenance" section for cleaning instructions.
	Highest point of discharge line is less than 5'.	Check valve may allow some condensate to drain out of line into reservoir. This is normal.
E. LIQUID LEAKS FROM AROUND CHECK VALVE.	Check Valve is too tight or too loose.	Check valve should be hand tight, then tighten an additional 1/2 turn with a 9/16" wrench.
	O-ring damaged.	Replace with a 1/2 ID X 11/16" OD X 3/32" thick O-ring or contact Star Service Station.



⚠ WARNING Before servicing a pump, always shut off the main power breaker and then unplug the pump - making sure you are not standing in water and are wearing insulated, protective-sole shoes. Under flooded conditions, contact your local electric company or a qualified

licensed electrician for disconnecting electrical service prior to pump removal. If the above checklist does not solve the problem, consult Star Water Systems Technical Service Department 1-800-345-9422 - **Do not** attempt to service or otherwise disassemble pump.

NOTES:

