

1996

Refrigerant Leakage Flow Evaluation for Scroll Compressors

N. Ishii

Osaka Electro-Communication University

K. Bird

Matsushita Compressor Corporation of America

K. Sano

Matsushita Electric Industrial Co.

M. Oono

Matsushita Electric Industrial Co.

S. Iwamura

Matsushita Electric Industrial Co.

See next page for additional authors

Follow this and additional works at: <https://docs.lib.purdue.edu/icec>

Ishii, N.; Bird, K.; Sano, K.; Oono, M.; Iwamura, S.; and Otokura, T., "Refrigerant Leakage Flow Evaluation for Scroll Compressors" (1996). *International Compressor Engineering Conference*. Paper 1175.
<https://docs.lib.purdue.edu/icec/1175>

This document has been made available through Purdue e-Pubs, a service of the Purdue University Libraries. Please contact epubs@purdue.edu for additional information.

Complete proceedings may be acquired in print and on CD-ROM directly from the Ray W. Herrick Laboratories at <https://engineering.purdue.edu/Herrick/Events/orderlit.html>

Authors

N. Ishii, K. Bird, K. Sano, M. Oono, S. Iwamura, and T. Otokura

REFRIGERANT LEAKAGE FLOW EVALUATION FOR SCROLL COMPRESSORS

by

Noriaki Ishii¹, Kenichi Bird², Kiyoshi Sano³, Mamoru Oono⁴,
Shinji Iwamura⁴ and Takayuki Otokura⁵

¹ Professor, Faculty of Engineering, Osaka Electro-Communication University, Neyagawa, Osaka 572, Japan, Tel: +81-720-20-4561; Fax: +81-720-20-4677; E-mail: ishii@isc.osakac.ac.jp

² Engineer, Technical Center, Matsushita Compressor Corp. of America, One Panasonic Way, P. O. Box 1418, Mooresville, NC 28115, Tel: (704)664-8184; Fax: (704)664-9395

³ Senior Staff Engineer, Air Conditioning Research,

⁴ Engineer, Compressor Division, Matsushita Electric Industrial Co., Ltd. (Panasonic), Noji-cho, Kusatsu-shi, Shiga 525, Japan, Tel: +81-775-67-9801, Fax: +81-775-61-3201.

⁵ Graduate Student, Faculty of Engineering, Osaka Electro-Communication University.

ABSTRACT

This paper presents a theoretical evaluation for the refrigerant gas leakage flows through the axial and radial clearances between the fixed and orbiting scrolls in scroll compressors, based on an incompressible and viscous flow theory. First, the time-dependent pressure drops in an initially pressurized closed vessel, due to refrigerant leakage flow through the axial or radial clearance, were carefully measured to address the refrigerant leakage effects. Subsequently, the time-dependent pressures were carefully simulated by a simple incompressible and viscous flow theory, thus resulting in a good agreement with the measured results. Additionally, the refrigerant leakage flows were calculated by a compressible and viscous flow theory to simulate the time-dependent pressure drops, but any reasonable result could not be ensured. The present paper concluded that the refrigerant leakage flows in scroll compressors can be well simulated by a simple incompressible and viscous flow theory assuming an entire turbulent leakage flow and a difficult treatment, such as a compressible and viscous flow simulation, is not necessarily useful.

1. INTRODUCTION

High efficiency is a major consideration in designing refrigerant compressors used for air conditioners or refrigerators. A slight improvement in compressor efficiency results in a significant energy savings. When designing refrigerant compressors, therefore, one should try to minimize the frictional power loss at each pair of the compressor elements and also the refrigerant leakage power loss at each clearance between the compressor elements.

The authors paid a special attention to a close relation between the frictional power losses and the major dimensions determining the size of compression mechanism, thus presenting a possible optimum design in mechanical efficiency [1-3]. The suction volume of scroll compressors is determined by the major parameters, such as the involute base circle diameter, the scroll depth, the scroll thickness and the number of scroll turns, and, subsequently, there are many combinations of major parameters that result in a scroll compressor with the same suction volume. Depending upon the selected combination of these major parameters, the frictional power losses in scroll compressors change, resulting in different mechanical efficiencies. Similar discussion can be made for volumetric efficiency: depending upon the selected combination of the major parameters, the refrigerant leakage flow rate from each clearance between the compressor elements changes, resulting in different volumetric efficiencies.

In order to computer simulate the volumetric efficiency for various combination of the major parameters, a simple method to evaluate refrigerant leakage flows in scroll compressors has to be established. Scroll compressors have axial and radial clearances between compressor elements, thus causing the refrigerant leakage from higher compression chamber. This study presents a theoretical evaluation for the refrigerant gas leakage flows from the axial and radial clearances, based on an incompressible and viscous flow theory.

The authors paid a special attention to a time-dependent pressure drop due to leakage through clearances, which implies a serious information on leakage feature itself. Two leakage test models for the axial and radial clearances were made, which comprise a test clearance sandwiched between two pressure chambers. One of the chambers was connected to an initially pressurized closed vessel with a large volume and other was opened to the atmosphere. Depending upon the leakage flow through the test clearance, the pressurized chamber decreases in pressure. Before starting the leakage tests, the test model was well warmed up in a refrigeration cycle until the temperature of the test model itself reaches to the same temperature as the discharged high pressure refrigerant. The time-dependent pressure drops were precisely measured for various initial pressures and test clearances. Subsequently, in order to simulate the measured time-dependent pressure drops, the refrigerant leakage flows through the axial and radial clearances were calculated by a simple incompressible and viscous flow theory, where an entire turbulent flow was assumed. In order to examine other possibilities to simulate the measured pressure drops, the refrigerant leakage flows were re-calculated by a compressible and viscous flow theory, where Fanno flow was assumed.

2. TEST MODELS FOR REFRIGERANT LEAKAGE IN SCROLL COMPRESSORS

Scroll compressors have two kind of leakage flows from a higher pressure chamber to a lower pressure chamber: one is the leakage flow through the axial clearance between the orbiting scroll end plate and the fixed scroll, as shown in Figure 1b; other is the leakage flow through the radial clearance between the orbiting and fixed scrolls, as shown in Figure 1c. The axial clearance is represented by δ_a and the radial clearance is by δ_r . The pressure in compression chambers is represented by p_0 , p_1 and p_2 , and the suction pressure is by p_s . The differences in these pressures cause the leakage flows.

In order to examine the leakage flows in scroll compressors, two test models were made, as shown in Figure 2. Diagram (a) is for the leakage flow through the axial clearance, where the length and depth of the axial clearance were fixed at values of 3.52 mm and 14.5 mm, respectively. Diagram (b) is for the leakage flow through the radial clearance, where the orbiting and fixed scrolls with an involute curve were represented by two circular arcs. The radii of the circular arcs were fixed at 25 mm and 30 mm, respectively, and the depth of the radial clearance was fixed at 15.0 mm. Both axial and radial clearances were carefully adjusted at 10 μm and 20 μm , with an error of about 4 to 5 μm , by using a non-contact type displacement transducer.

The high pressure chamber on the right hand side of the test clearance was directly connected to a closed vessel with a volume of about 850 cm^3 . The test model with a closed vessel was initially put into a refrigeration cycle, between the compressor discharge port and the condenser, for about one hour, to warm the test model up. After the test model reached a stable temperature, the test model with a closed vessel was separated from the refrigeration cycle and the low pressure chamber was instantaneously made open to the atmosphere. The pressure in the high pressure chamber with a closed vessel decreases due to refrigerant leakage from the test clearance, and its time-dependent pressure drop was measured by a semi-conductor strain gauge type pressure transducer. Before the leakage test was started, a special attention was paid to remove an oil collected in a closed vessel during warming up in the refrigeration cycle; otherwise the oil would have foamed, thus inducing a bad effect upon the present leakage tests.

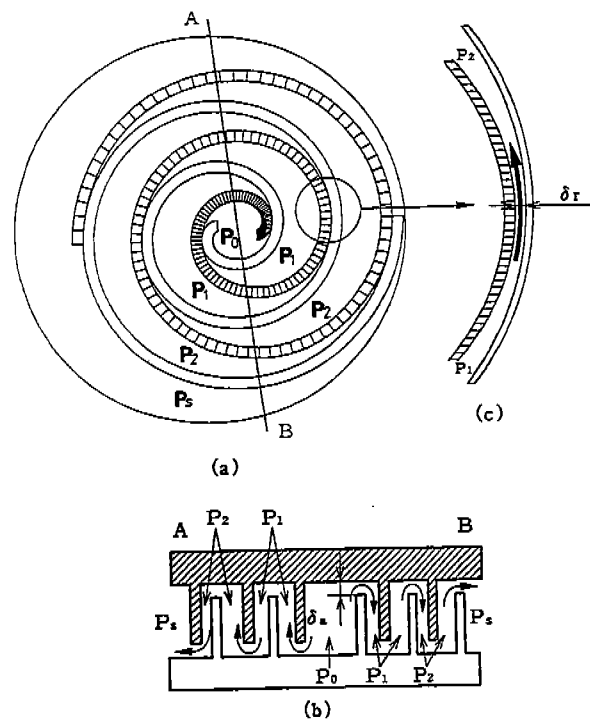

Figure 1. Refrigerant leakage flows in scroll compressors: (a) cross-sectional view of scroll compressor; (b) leakage flow through axial clearance; (c) leakage flow through radial clearance.

3. LEAKAGE TROUGH AXIAL CLEARANCE

Test Results The test model for the axial clearance, shown in Figure 2a, presented the test results for the time-dependent pressure drops due to leakage of the refrigerant R22, shown by solid lines in Figure 3, where the initial pressure was adjusted at 7 different values from about 0.32 MPa to about 1.47 MPa. The initial pressures are listed up in Table 1, where the measured initial temperatures also are shown. The test results shown in Figure 3a is for the test axial clearance of 10 μm . Due to the refrigerant leakage, only through the axial clearance, the high pressure chamber decreases in pressure, approaching the atmospheric pressure of about 0.1 MPa in the low pressure chamber. When the axial clearance is adjusted to a larger value of 20 μm , as shown in Figure 3b, the pressure drops become far rapid, compared with the data in Figure 3a. For comparison, a pressure drop curve for the axial clearance of 10 μm , one of the test data in Figure 3a, is shown by a chain line.

Simulation of Pressure Drop Assuming an incompressible and viscous flow for the refrigerant leakage through the axial clearance, the loss of head between the high pressure chamber with pressure, P , and the low pressure chamber with pressure P_a can be related with the mean leakage flow velocity, u_m , as shown in the following expression:

$$\frac{P - P_a}{\rho g} = \lambda \frac{L}{4m} \frac{u_m^2}{2g}, \quad (1)$$

where L is the length of the axial clearance. The gravity acceleration is represented by g . The hydraulic mean depth for the axial clearance with a rectangular cross section, represented by m , is given by

$$m = \frac{\delta W}{2(\delta + W)}, \quad (2)$$

where δ and W are the height and depth of the axial clearance, respectively. The specific mass, ρ , in (1) can be calculated from the following expression, assuming a polytropic change in the high pressure chamber:

$$\rho = \rho_0 \left(\frac{P}{P_0} \right)^{1/n}, \quad (3)$$

where ρ_0 and P_0 are the initial values for the specific mass and pressure, respectively. The friction factor is represented by λ in (1), which is given by the following expression, assuming an entire turbulent flow for the refrigerant leakage through the rectangular axial clearance with small aspect ratio:

$$\lambda = 0.35 R_e^{-0.25}, \quad (4)$$

where the Reynolds number R_e is defined by

$$R_e = \frac{4m u_m}{\mu / \rho}. \quad (5)$$

The viscosity coefficient is represented by μ .

Given a pressure difference between P and P_a , the mean leakage velocity u_m can be computer calculated from (1), and therewith the mass flow rate Q can be calculated as follows:

$$Q = \rho \delta W u_m. \quad (6)$$

This mass flow rate causes a pressure drop ΔP for a small time Δt , given by

$$\Delta P = \frac{P_0}{G_0^n} n G^{n-1} Q \Delta t, \quad (7)$$

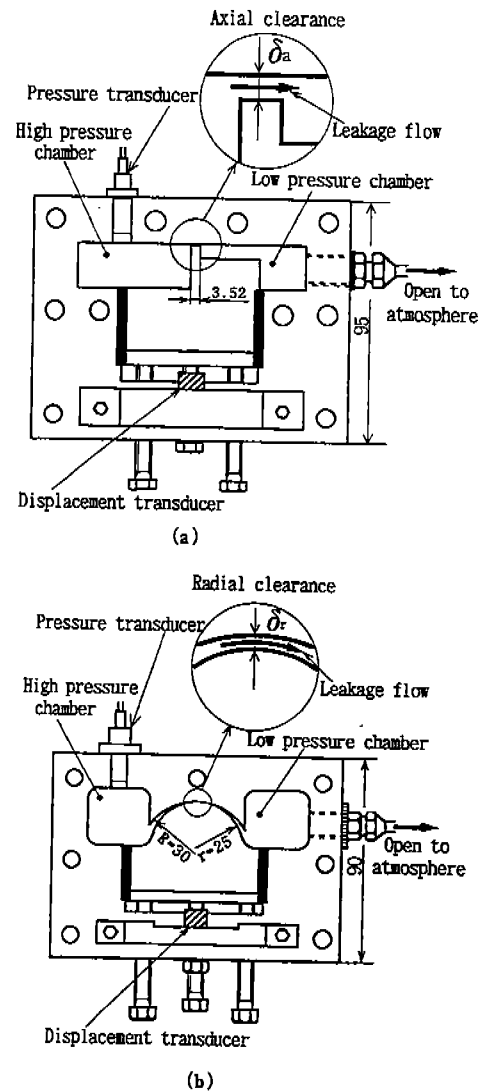

Figure 2. Test models for refrigerant leakage in scroll compressors: (a) axial clearance model; (b) radial clearance model.

where G is the refrigerant mass in the high pressure chamber, calculated by the following integration :

$$G = G_0 - \int_0^t Q dt. \quad (8)$$

G_0 is an initial value of the refrigerant mass. Using expressions (7) and (6), the pressure drop in the high pressure chamber, caused by the refrigerant leakage through the axial clearance, can be computer simulated.

The test clearance was adjusted at $10 \mu\text{m}$ and $20 \mu\text{m}$ as precise as possible, but a possible error of about 3 to $4 \mu\text{m}$ was not avoidable in adjusting. In computer simulation for pressure drops, thereupon, the axial clearance δ was treated as an unknown factor and its value was determined so that a simulated pressure drop shows a good agreement with the corresponding test result. As presented in Table 1, the calculated axial clearances took a value from $8.7 \mu\text{m}$ to $9.0 \mu\text{m}$ for the test clearance $10 \mu\text{m}$, and from $16.2 \mu\text{m}$ to $17.1 \mu\text{m}$ for the test clearance

$20 \mu\text{m}$. Conclusively the calculated clearances have a good agreement with each test clearances. The simulated pressure drop curves are shown by dotted lines in Figure 3. One may conclude that the present theoretical evaluation for the leakage flow through the axial clearance, assuming the incompressive, viscous and turbulent flow, provide a good simulation for the test results.

4. LEAKAGE TROUGH RADIAL CLEARANCE

Test Results Test results for the pressure drop in the high pressure chamber, due to leakage of the refrigerant R22 through the radial clearance in the test model shown in Figure 2b, are shown by solid lines in Figure 4. The initial pressures are listed up in Table 2, where the measured initial temperatures also are shown. Figure 4a is for the test radial clearance of $10 \mu\text{m}$. For comparison a pressure drop curve due to leakage through the axial clearance of $10 \mu\text{m}$, one of the test data in Figure 3a, is shown by a chain line: the leakage effect for the radial clearance is larger than for the axial clearance. Figure 4b is for the test radial clearance of $20 \mu\text{m}$, where for comparison a pressure drop curve for the radial clearance of $10 \mu\text{m}$, one of the test data in Figure 4a, is shown by a chain line.

Simulation of Pressure Drop The flow path between two scrolls was simulated by two circular arcs with the radii of $R(=30 \text{ mm})$ and $r(=25 \text{ mm})$, in the test model shown in Figure 2b. For leakage flow analysis, an enlarged configuration of the flow path is shown in Figure 5, where the minimum clearance is represented by δ . This minimum clearance is hereafter termed a "radial clearance." The height of flow path between the two circular arcs, h , can be calculated by the following expression:

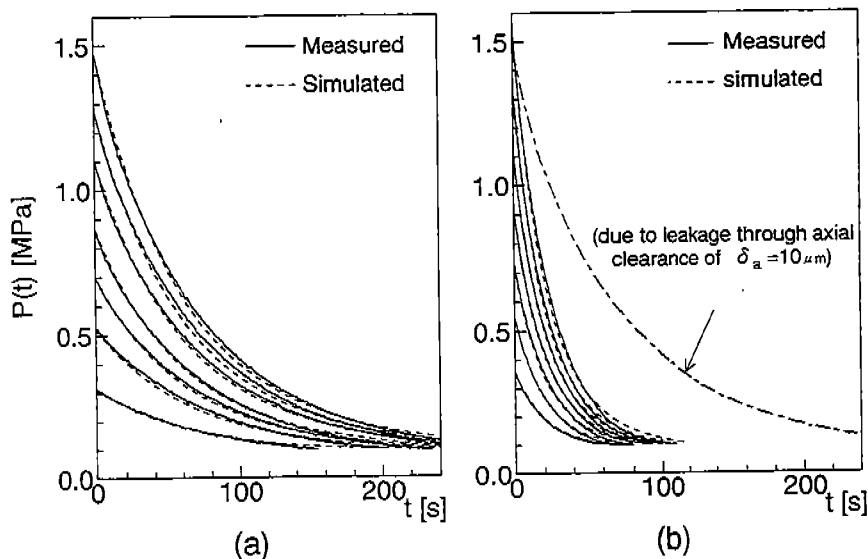

Figure 3. Pressure drops due to refrigerant leakage through axial clearance: (a) test clearance $\delta_a = 10 \mu\text{m}$; (b) test clearance $\delta_a = 20 \mu\text{m}$.

Table 1. Calculated axial clearance

Test axial clearance $\delta_a: 10 \mu\text{m}$				Test axial clearance $\delta_a: 20 \mu\text{m}$			
Initial state		Simulated Clearance [μm]		Initial state		Simulated Clearance [μm]	
Pres. [MPa]	Temp. [$^{\circ}\text{C}$]	Incompressive	Compressive	Pres. [MPa]	Temp. [$^{\circ}\text{C}$]	Incompressive	Compressive
1.4	53.3	8.9	14.8	1.52	56.8	16.2	32.0
1.2	52.8	8.9	13.8	1.32	56.0	16.5	32.0
1.1	49.8	8.9	13.8	1.12	55.2	16.5	31.0
0.8	51.6	9.0	13.8	0.92	54.8	16.7	30.0
0.7	52.8	8.9	13.6	0.73	52.2	16.5	28.0
0.5	53.6	8.7	12.8	0.55	55.2	17.1	27.0
0.3	54.4	8.8	13.8	0.36	54.8	16.9	26.0

$$h = R - (R - r - \delta) \cos \phi - \sqrt{r^2 - (R - r - \delta)^2 \sin^2 \phi} \quad (9)$$

where ϕ is the counter clockwise angle from the minimum clearance position. The loss of head between the high and low pressure chambers is physically caused by a frictional loss due to the leakage flow viscosity, which can be roughly calculated by integrating a small frictional loss in a small flow path length, R by $d\phi$:

$$\frac{P - P_a}{\rho g} = \int_{-\phi_0}^{\phi_0} \lambda \frac{R d\phi u_\phi^2}{4m_\phi 2g} \quad (10)$$

where the hydraulic mean depth m_ϕ is given by

$$m_\phi = \frac{hW}{2(h+W)} \quad (11)$$

The flow velocity u_ϕ is related to a representative leakage flow velocity u_0 at the minimum clearance, assuming a continuous flow:

$$u_\phi = \frac{\delta}{h} u_0 \quad (12)$$

and the Reynolds number Re is given by the following expression:

$$Re = \frac{4m_\phi u_\phi}{\mu/\rho} \quad (13)$$

Therewith the friction factor λ can be calculated from (4), assuming an entire turbulent leakage flow.

Given a pressure difference between P and P_a , the leakage velocity at the minimum clearance, u_0 , can be computer calculated from (10) and (12), and therewith the mass flow rate Q can be calculated by

$$Q = \rho \delta W u_0 \quad (14)$$

Subsequently, using expressions (14) and (7) the pressure drop in the high pressure chamber, caused by the refrigerant leakage through the radial clearance, can be computer simulated.

In computer simulation for pressure drops, the radial clearance δ was determined so that a simulated pressure drop shows a good agreement with the corresponding test result, as presented in Table 2. The calculated axial clearances took a value from 7.0 μm to 9.5 μm for the test clearance 10 μm , and from 13.0 μm to 15.5 μm for the test clearance 20 μm . The simulated pressure drop

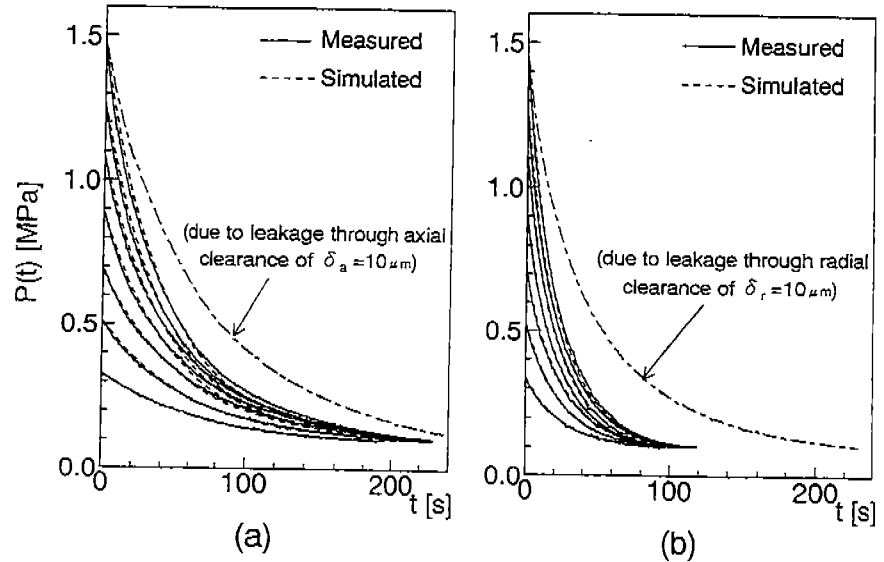

Figure 4. Pressure drops due to refrigerant leakage through radial clearance: (a) test clearance $\delta_r = 10 \mu\text{m}$; (b) test clearance $\delta_r = 20 \mu\text{m}$.

Table 2. Calculated radial clearance

Test radial clearance $\delta_r: 10 \mu\text{m}$				Test radial clearance $\delta_r: 20 \mu\text{m}$			
Initial state		Simulated Clearance [μm]		Initial state		Simulated Clearance [μm]	
Pres. [MPa]	Temp. [$^{\circ}\text{C}$]	Incompressive	Compressive	Pres. [MPa]	Temp. [$^{\circ}\text{C}$]	Incompressive	Compressive
1.47	53.2	9.5	26	1.47	57.0	15.5	41
1.26	51.6	9.5	26	1.27	54.7	15.0	41
1.08	56.5	9.0	25	1.11	53.0	15.3	38
0.90	57.3	8.5	19	0.91	53.0	15.0	37
0.68	54.1	7.8	18	0.72	52.5	14.0	34
0.52	56.5	7.5	18	0.53	52.0	14.0	30
0.33	57.5	7.0	18	0.34	53.0	13.0	29

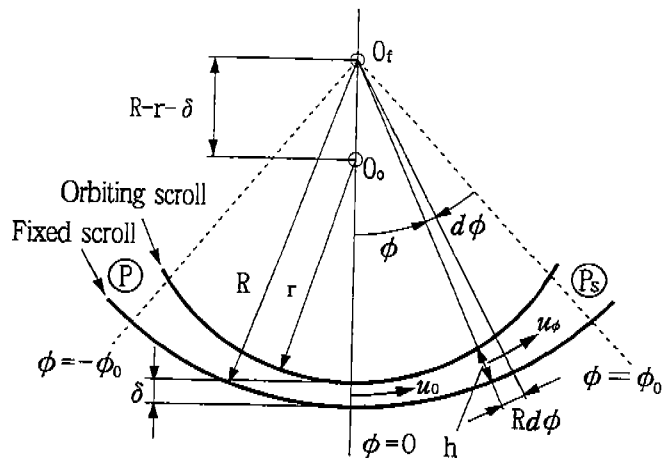

Figure 5. Equivalent flow model for leakage flow through radial clearance.

curves are shown by dotted lines in Figure 4. One may conclude that the present theoretical evaluation for the leakage flow through the radial clearance also, assuming the incompressible, viscous and turbulent flow, provide a good simulation for the test results.

5. POSSIBILITY OF SIMULATION BY COMPRESSIVE AND VISCOUS THEORY

In order to examine a possibility of simulation by a compressive and viscous theory, it was assumed that the refrigerant leakage can be treated as a Fanno flow that is an adiabatic flow with friction through a path with a constant cross-sectional area. Similar calculations were made to determine the axial and radial clearances, so that a simulated pressure drop shows a good agreement with the corresponding test result. As shown in Tables 1 and 2, the calculated clearances are all too large compared with the corresponding test clearances, respectively. Its disagreement becomes larger, as the initial pressure is higher. Some examples for the simulated pressure drops are shown in Figure 6, where the clearance was assumed to be the same as the test clearance. The dotted curves simulated by the incompressible theory have a close agreement with each measured curve, but the chain lines simulated by the compressive theory are far different from each measured curve.

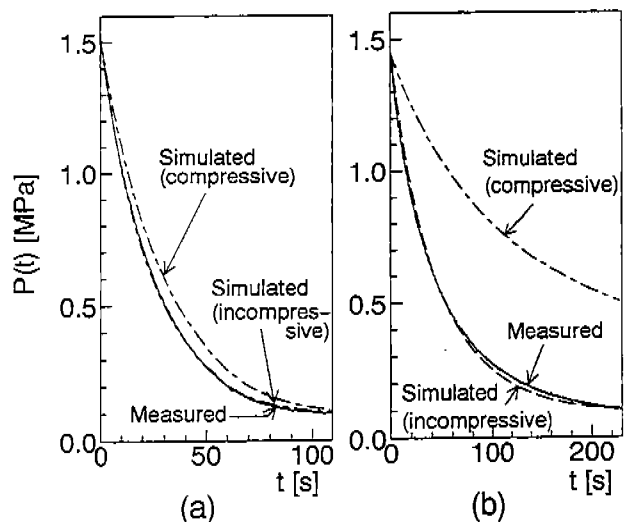

Figure 6. Pressure drop, simulated by compressive and viscous theory: (a) due to axial clearance of 20 μm ; (b) due to radial clearance of 10 μm .

6. CONCLUSION

The refrigerant leakage flows in scroll compressors, through the axial and radial clearances, can be well simulated by the most simple incompressible and viscous flow theory assuming an entire turbulent leakage flow. A difficult treatment, such as a compressible and viscous flow simulation, is not necessarily useful for the refrigerant leakage flows in scroll compressors.

ACKNOWLEDGEMENTS

The authors would like to express their gratitude to Mr. Jirou Yuuda, Head of the Air Conditioning Research Laboratory, and Mr. Tomio Kawabe, Head of the Compressor Division, for their financial support in carrying out this work and their permission to publish these results. The authors also would like to express their sincere thanks to Mr. Hiraku Matsui and Mr. Noriyuki Morita for their energetic works for leakage tests and computer simulations.

REFERENCES

- (1) Ishii, N. *et al.*, Optimum Combination of Dimensions for High Mechanical Efficiency of a Rolling-Piston Rotary Compressor, Proc. International Compressor Engineering Conference at Purdue, July, 1990, pp.418-424.
- (2) Ishii, N. *et al.*, Optimum Combination of Parameters for High Mechanical Efficiency of a Scroll Compressor, Proc. International Compressor Engineering Conference at Purdue, July, 1992, pp.118a1-118a8.
- (3) Ishii, N. *et al.*, A Study on High Mechanical Efficiency of a Scroll Compressor with Fixed Cylinder Diameter, Proc. International Compressor Engineering Conference at Purdue, July, 1994, pp.677- 682.